

# We are IntechOpen, the world's leading publisher of Open Access books Built by scientists, for scientists

**4,800**

Open access books available

**122,000**

International authors and editors

**135M**

Downloads

Our authors are among the

**154**

Countries delivered to

**TOP 1%**

most cited scientists

**12.2%**

Contributors from top 500 universities



**WEB OF SCIENCE™**

Selection of our books indexed in the Book Citation Index  
in Web of Science™ Core Collection (BKCI)

Interested in publishing with us?  
Contact [book.department@intechopen.com](mailto:book.department@intechopen.com)

Numbers displayed above are based on latest data collected.

For more information visit [www.intechopen.com](http://www.intechopen.com)



---

# **Optimization of Multiple Responses in Quench Hardening and Tempering Process in Steel Wires by Means Design of Experiments and Desirability Method**

---

Cristie Diego Pimenta, Messias Borges Silva, Rosinei Batista Ribeiro, Roberto Campos Leoni, Ricardo Batista Penteado, Fabrício Maciel Gomes and Valério Antonio Pamplona Salomon

Additional information is available at the end of the chapter

<http://dx.doi.org/10.5772/56544>

---

## **1. Introduction**

This research aims to show factors influence study and optimization of multiple mechanical properties responses of thermal treatment process quench hardening and tempering in steel wires used in manufacturing automotive springs. For the data collection and process statistical modeling, it was used the following methodologies: design of experiments and multiple linear regression. In this case, these methods were used to assist in a statistical modeling development which might replace the traditional way to adjust the input variables of thermal treatment process. This process setup is currently done by means of mechanical tests of pilot samples which is referred to laboratory analysis, after going by all stages of a thermal treatment for quenching hardening and tempering. Results obtained in this stage, are used to regulate the annealing furnace, implying considerable analysis and standby time, reducing, this way, the process productivity.

## **2. Bibliografic review**

### **2.1. Thermal treatment and mechanical tests**

According to Mayers and Chawla (1982), in a tensile strength test, the specimen is fixed on a testing machine head, which applies an effort that tends to elongate it up to rupture, where

deformations are measured by means of a device called extensometer. The test is carried out on a specimen with standardized dimensions, so that the obtained results can be compared, reproduced and quantified at the machine itself. Normally, the test occurs up to the material failure (which is classified as destructive) and allows measuring the material strength and deformation depending on the applied strain. Above a certain strain level, materials start to deform plastically until there is a rupture, point where it is obtained the traction resistance limit. Universal testing machine for traction is the most used and the most common force units are kilogram-force per square millimeter ( $\text{Kgf/mm}^2$ ) or MegaPascal (MPa).

Yield is the attribute presented by certain materials when undergoing large plastic transformations before their break when subjected to traction tension. In steel specimens, yield is measured by reduction of cross-sectional area which occurs before rupture. Yield is given by the ratio between variation of cross-sectional area of specimen (initial area - final area) and the value of initial area of cross-section (MAYERS; Chawla, 1982). Yield or area reduction is usually expressed as a percentage, showing how much of cross-sectional area of resistive section of specimen was reduced after force application in tensile test.

According to Callister (2002), hardness is a metal resistance measure to penetration. The most common methods to determine a metal hardness are Brinell, Vickers and Rockwell. In this research, only the Brinell method (BH) is used. Brinell hardness values (BH), as shown in Figure 1, are calculated by dividing applied load by penetration area. The diameter penetrator (D) is a hardened steel ball for materials of medium or low hardness, or tungsten carbide for high hardness materials. The test machine has a light microscope which makes the circle diameter measurement (d, in mm), which corresponds to the spherical cap projection printed on the sample. Brinell hardness (BH) is given by the applied load (P, in kgf) divided by the print area, as shown in equation 1.

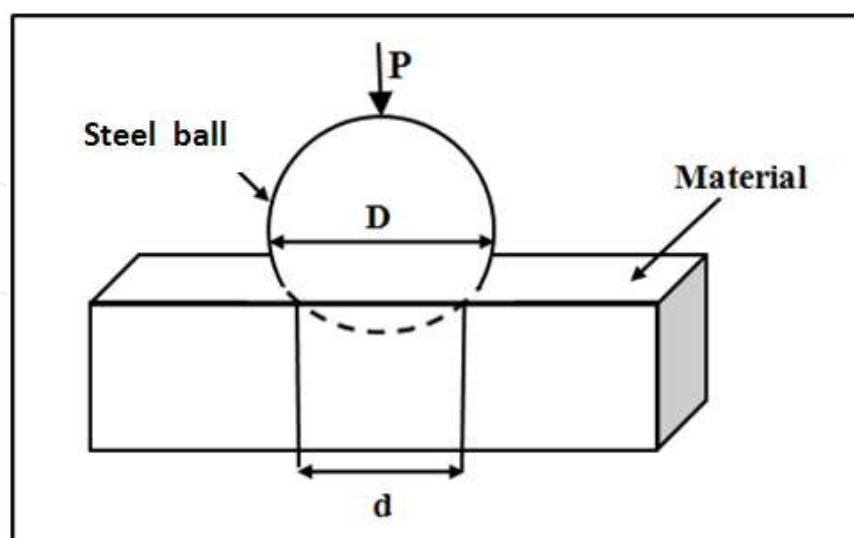

**Figure 1.** Brinell hardness (BH) method Illustration.

Source: Authors elaboration.

$$BH = \frac{2P}{\pi D \left( D - \sqrt{D^2 - d^2} \right)} \quad \left[ \text{kgf/mm}^2 \right] \quad (1)$$

## 2.2. Statistical methods used

According to Lima et al. (2011), Silva and Silva (2008) and Granato et al. (2011), the design of experiments (DOE) is very adequate to study several process factors and their interactions complexity in order to solve problems by means of statistical analysis. According to Montgomery (2010) and Benyounis and Olabi (2008), blocking is a technique used to improve comparison accuracy among interest factors and can be used in conjunction with the multiple linear regression technique for process statistical modeling. Blocking can be employed in factorial planning when it is necessary to control variability coming from disturbing sources known, which may influence the results.

Montgomery and Runger (2003) state that multiple linear regression is used for situations involving more than one regressor, and the models can include interaction effects. An interaction between two variables can be represented by a cross term, for if we assume that  $x_3 = x_1x_2$  and  $\beta_3 = \beta_{12}$ , then the model, including interaction terms, will be as shown in equation 2.

$$Y = \beta_0 + \beta_1x_1 + \beta_2x_2 + \beta_3x_3 + \dots + \varepsilon \quad (2)$$

In this expression, Y is the dependent variable; the independent variables are represented by  $x_1, x_2, \dots, x_n$  and  $\varepsilon$  is the random error term. The term "linear" is used because the equation is a linear function of the unknown parameters  $\beta_0, \beta_1, \beta_2$  and  $\beta_n$ . In this model, the parameter  $\beta_0$  is the plane intersection;  $\beta_1, \beta_2$  and  $\beta_n$  are the regression partial coefficients.

The desirability method is a method used for determining the best conditions for process adjustment, making possible simultaneous optimization of multiple responses. This being so, the best responses conditions are obtained simultaneously minimizing, maximizing or seeking nominal values of specifications, depending on the most convenient situation for the process (WANG, WAN, 2009).

Each one of responses ( $Y_1, Y_2 \dots Y_k$ ) of original set is transformed, such that  $d_i$  belongs to interval  $0 \leq d_i \leq 1$ . The  $d_i$  value increases when the  $i$ th response approaches the imposed limits. Equation 3 is used to find the D global index, from combination of each one responses processed through a geometric mean.

$$D = \left( d_1(Y_1) \times d_2(Y_2) \dots \times d_k(Y_k) \right)^{\frac{1}{k}} \quad (3)$$

As a result of geometric mean represented by equation 3, the value D evaluates, in a general way, the levels of the combined set of responses. It is an index also belonging to interval [0, 1]

and will be maximized when all responses approach as much as possible of its specifications. The closer of one D is, the closer the original responses will be of their respective specification limits. The general optimal point of system is the optimal point achieved by maximizing the geometric mean, calculated from individual desirability functions (Paiva, 2008). According to Paiva (2008), advantage of using geometric mean is to make the overall solution is achieved in a balanced way, allowing all responses can achieve the expected values and forcing algorithm to approach the imposed specifications.

According to Derringer and Suich (1980), the algorithm will depend on the optimization type desired for response (maximization, minimization or normalization) of desired limits within the specification and the amounts (weights) of each one response, which identifies the main characteristics of different optimization types, as follows:

- Minimize Function: The desirability function value increases as the original response value approaches a minimum target value;
- Normalize Function: When response moves toward the target, the desirability function value increases;
- Maximize Function: The desirability function value increases when the response value increases.

Paiva (2008) and WU (2005) state that when a response maximization is wished, the transformation formula is shown in equation 4:

$$d_i = \begin{cases} 0 & \hat{Y}_i < LSL \\ \left[ \frac{\hat{Y}_i - L_i}{T_i - L_i} \right]^R & L_i \leq \hat{Y}_i \leq T_i \\ 1 & \hat{Y}_i > T_i \end{cases} \quad (4)$$

Where:  $L_i$ ,  $T_i$  and  $H_i$  are, respectively, the values of major, minor and acceptable target for the  $i$ th response.

The R value, in Equation 4, indicates a preponderance of the superior limit (LSL). Values higher than unity should be used when the response ( $Y_i$ ) increases rapidly above  $L_i$ . Therefore,  $d_i$  increases slowly, while the response value is being maximized. Consequently, to maximize D, the  $i$ th response must be much larger than  $L_i$ . One can choose  $R < 1$ , when it is critical to find values for the response below the fixed limits.

In cases where the objective is to reach a target value, the transformation formulation stops being unilateral and becomes bilateral. The bilateral formulation, represented by equation 5, occurs when the interest response has two restrictions: one maximum and the other one minimum.

$$d_i = \begin{cases} 0 & \hat{Y}_i < L_i \text{ ou } \hat{Y}_i > H_i \\ \left[ \frac{H_i - \hat{Y}_i}{H_i - T_i} \right]^R & T_i \leq \hat{Y}_i \leq H_i \\ \left[ \frac{\hat{Y}_i - L_i}{T_i - L_i} \right]^R & L_i \leq \hat{Y}_i \leq T_i \end{cases} \quad (5)$$

### 3. Materials and methods

#### 3.1. Material, factors selection and experimental organization

The material used was SAE 9254 steel wire, with diameter gauges 2.00 mm and 6.50 mm. Factors investigated in this research are:

- Speed of wire passage inside the furnace (in m/s);
- Polymer concentration, quenching medium (in %);
- Lead temperature in tempering (in °C).

The steel wire diameter was also considered as an important factor, for there was assumption that its mass could influence results of investigated mechanical properties. Nevertheless, in this research, it was used the blocks analysis methodology, that is, for block 1, it was allocated experiments related only to diameter 2.00 mm, and for block 2, experiments related to 6.50 mm diameter as shown in Table 1.

Experiments	Speed	Lead Temperature	% Polymer
1	-	-	-
2	+	-	-
3	-	+	-
4	+	+	-
5	-	-	+
6	+	-	+
7	-	+	+
8	+	+	+

**Table 1.** Factorial Matrix 2<sup>3</sup>

Factors such as speed, lead temperature and polymer concentration were tested by means of the factorial planning, using the matrix  $2^3$ .

For experiments planning accomplishment, reduced variables ( $\beta$ ) were used rather than physical variables (real adjustments) of investigated factors, in order to preserve the confidential data of the company which funds the research. Variables reduction was calculated according to Montgomery and Runger (2003), using the physical value ( $\alpha$ ) that one wants to test subtracted from the mean ( $\mu$ ) between the minimum and maximum of factors adjustments. The result was divided by half the amplitude ( $R$ ) between the minimum and maximum values of factors adjustment. Thus, the reduced variables dimensionality was restricted to the range [-1 to 1], according to equation 6 and Table 2.

$$\beta = \frac{\alpha - \mu}{\frac{R}{2}} \quad (6)$$

Input variables	Values (physical units)	Values (reduced variables)
Speed (m/s)	Minimum / Maximum	-1 / 1
Lead temperature (°C)	Minimum / Maximum	-1 / 1
Polymer concentration (%)	Minimum / Maximum	-1 / 1

**Table 2.** Transformation of physical variables to reduced variables

## 4. Results and discussion

### 4.1. Sequence of experiments and statistical analysis

In the experiments, all replicas related to block 1 were initially carried out, and then the ones corresponding to block 2. Six replicas were used for each experimental condition. Replications were randomized and sequenced using a notation from 1 to 8, corresponding to each experiment order for each block individually. This experimental sequence is displayed in parentheses and in subscript format next to values obtained from mechanical properties as displayed in Tables 3, 4 and 5.

Experiments	Replica 1	Replica 2	Replica 3	Replica 4	Replica 5	Replica 6
1/Block 1	2149 <sub>(1)</sub>	2148 <sub>(1)</sub>	2146 <sub>(2)</sub>	2161 <sub>(8)</sub>	2167 <sub>(1)</sub>	2160 <sub>(6)</sub>
2/Block 1	2157 <sub>(4)</sub>	2155 <sub>(7)</sub>	2157 <sub>(3)</sub>	2151 <sub>(7)</sub>	2157 <sub>(4)</sub>	2157 <sub>(2)</sub>
3/Block 1	1924 <sub>(3)</sub>	1922 <sub>(3)</sub>	1920 <sub>(1)</sub>	1921 <sub>(5)</sub>	1920 <sub>(6)</sub>	1918 <sub>(4)</sub>

Experiments	Replica 1	Replica 2	Replica 3	Replica 4	Replica 5	Replica 6
4/Block 1	1924 <sup>(2)</sup>	1924 <sup>(8)</sup>	1922 <sup>(8)</sup>	1943 <sup>(6)</sup>	1945 <sup>(8)</sup>	1945 <sup>(5)</sup>
5/Block 1	2108 <sup>(6)</sup>	2106 <sup>(5)</sup>	2108 <sup>(7)</sup>	2104 <sup>(2)</sup>	2102 <sup>(7)</sup>	2109 <sup>(8)</sup>
6/Block 1	2136 <sup>(5)</sup>	2127 <sup>(4)</sup>	2127 <sup>(4)</sup>	2136 <sup>(3)</sup>	2134 <sup>(3)</sup>	2127 <sup>(3)</sup>
7/Block 1	1927 <sup>(7)</sup>	1926 <sup>(2)</sup>	1944 <sup>(5)</sup>	1935 <sup>(4)</sup>	1946 <sup>(2)</sup>	1947 <sup>(7)</sup>
8/Block 1	1946 <sup>(8)</sup>	1946 <sup>(6)</sup>	1946 <sup>(6)</sup>	1953 <sup>(1)</sup>	1951 <sup>(5)</sup>	1946 <sup>(1)</sup>
1/Block 2	1968 <sup>(1)</sup>	1974 <sup>(1)</sup>	1962 <sup>(3)</sup>	1971 <sup>(4)</sup>	1971 <sup>(8)</sup>	1974 <sup>(5)</sup>
2/Block 2	1980 <sup>(7)</sup>	1976 <sup>(4)</sup>	1988 <sup>(6)</sup>	1978 <sup>(2)</sup>	1980 <sup>(3)</sup>	1988 <sup>(2)</sup>
3/Block 2	1771 <sup>(3)</sup>	1764 <sup>(3)</sup>	1763 <sup>(7)</sup>	1773 <sup>(5)</sup>	1771 <sup>(5)</sup>	1764 <sup>(4)</sup>
4/Block 2	1796 <sup>(8)</sup>	1784 <sup>(2)</sup>	1797 <sup>(8)</sup>	1781 <sup>(3)</sup>	1796 <sup>(2)</sup>	1784 <sup>(3)</sup>
5/Block 2	1949 <sup>(5)</sup>	1963 <sup>(6)</sup>	1947 <sup>(1)</sup>	1951 <sup>(1)</sup>	1949 <sup>(4)</sup>	1947 <sup>(6)</sup>
6/Block 2	1992 <sup>(4)</sup>	1980 <sup>(5)</sup>	1976 <sup>(4)</sup>	1994 <sup>(8)</sup>	1980 <sup>(7)</sup>	1992 <sup>(7)</sup>
7/Block 2	1760 <sup>(2)</sup>	1768 <sup>(7)</sup>	1766 <sup>(5)</sup>	1763 <sup>(7)</sup>	1766 <sup>(6)</sup>	1763 <sup>(8)</sup>
8/Block 2	1787 <sup>(6)</sup>	1793 <sup>(8)</sup>	1785 <sup>(2)</sup>	1784 <sup>(6)</sup>	1784 <sup>(1)</sup>	1785 <sup>(1)</sup>

**Table 3.** Tensile strength results (MPa)

Experiments	Replica 1	Replica 2	Replica 3	Replica 4	Replica 5	Replica 6
1/Block 1	50 <sup>(1)</sup>	51 <sup>(1)</sup>	51 <sup>(2)</sup>	50 <sup>(8)</sup>	50 <sup>(1)</sup>	50 <sup>(6)</sup>
2/Block 1	50 <sup>(4)</sup>	50 <sup>(7)</sup>	50 <sup>(3)</sup>	50 <sup>(7)</sup>	50 <sup>(4)</sup>	50 <sup>(2)</sup>
3/Block 1	58 <sup>(3)</sup>	58 <sup>(3)</sup>	58 <sup>(1)</sup>	58 <sup>(5)</sup>	58 <sup>(6)</sup>	58 <sup>(4)</sup>
4/Block 1	58 <sup>(2)</sup>	58 <sup>(8)</sup>	58 <sup>(8)</sup>	56 <sup>(6)</sup>	56 <sup>(8)</sup>	56 <sup>(5)</sup>
5/Block 1	53 <sup>(6)</sup>	53 <sup>(5)</sup>	53 <sup>(7)</sup>	53 <sup>(2)</sup>	53 <sup>(7)</sup>	53 <sup>(8)</sup>
6/Block 1	51 <sup>(5)</sup>	52 <sup>(4)</sup>	52 <sup>(4)</sup>	51 <sup>(3)</sup>	51 <sup>(3)</sup>	52 <sup>(3)</sup>
7/Block 1	58 <sup>(7)</sup>	58 <sup>(2)</sup>	56 <sup>(5)</sup>	58 <sup>(4)</sup>	56 <sup>(2)</sup>	56 <sup>(7)</sup>
8/Block 1	56 <sup>(8)</sup>	56 <sup>(6)</sup>	56 <sup>(6)</sup>	55 <sup>(1)</sup>	56 <sup>(5)</sup>	56 <sup>(1)</sup>
1/Block 2	42 <sup>(1)</sup>	41 <sup>(1)</sup>	42 <sup>(3)</sup>	42 <sup>(4)</sup>	42 <sup>(8)</sup>	41 <sup>(5)</sup>
2/Block 2	41 <sup>(7)</sup>	41 <sup>(4)</sup>	40 <sup>(6)</sup>	41 <sup>(2)</sup>	41 <sup>(3)</sup>	40 <sup>(2)</sup>
3/Block 2	47 <sup>(3)</sup>	46 <sup>(3)</sup>	46 <sup>(7)</sup>	47 <sup>(5)</sup>	47 <sup>(5)</sup>	46 <sup>(4)</sup>
4/Block 2	44 <sup>(8)</sup>	45 <sup>(2)</sup>	44 <sup>(8)</sup>	45 <sup>(3)</sup>	44 <sup>(2)</sup>	45 <sup>(3)</sup>
5/Block 2	56 <sup>(5)</sup>	42 <sup>(6)</sup>	56 <sup>(1)</sup>	56 <sup>(1)</sup>	56 <sup>(4)</sup>	56 <sup>(6)</sup>
6/Block 2	40 <sup>(4)</sup>	41 <sup>(5)</sup>	41 <sup>(4)</sup>	40 <sup>(8)</sup>	41 <sup>(7)</sup>	40 <sup>(7)</sup>
7/Block 2	46 <sup>(2)</sup>	47 <sup>(7)</sup>	47 <sup>(5)</sup>	46 <sup>(7)</sup>	47 <sup>(6)</sup>	46 <sup>(8)</sup>
8/Block 2	44 <sup>(6)</sup>	44 <sup>(8)</sup>	45 <sup>(2)</sup>	45 <sup>(6)</sup>	45 <sup>(1)</sup>	45 <sup>(1)</sup>

**Table 4.** Yield point results in percentage (%)



Experiments	Replica 1	Replica 2	Replica 3	Replica 4	Replica 5	Replica 6
1/Block 1	608 <sup>(1)</sup>	606 <sup>(1)</sup>	606 <sup>(2)</sup>	611 <sup>(8)</sup>	611 <sup>(1)</sup>	611 <sup>(6)</sup>
2/Block 1	608 <sup>(4)</sup>	608 <sup>(7)</sup>	608 <sup>(3)</sup>	608 <sup>(7)</sup>	608 <sup>(4)</sup>	608 <sup>(2)</sup>
3/Block 1	544 <sup>(3)</sup>	542 <sup>(3)</sup>	542 <sup>(1)</sup>	542 <sup>(5)</sup>	542 <sup>(6)</sup>	542 <sup>(4)</sup>
4/Block 1	544 <sup>(2)</sup>	544 <sup>(8)</sup>	542 <sup>(8)</sup>	550 <sup>(6)</sup>	550 <sup>(8)</sup>	550 <sup>(5)</sup>
5/Block 1	594 <sup>(6)</sup>	594 <sup>(5)</sup>	594 <sup>(7)</sup>	594 <sup>(2)</sup>	594 <sup>(7)</sup>	594 <sup>(8)</sup>
6/Block 1	603 <sup>(5)</sup>	600 <sup>(4)</sup>	600 <sup>(4)</sup>	603 <sup>(3)</sup>	603 <sup>(3)</sup>	600 <sup>(3)</sup>
7/Block 1	544 <sup>(7)</sup>	544 <sup>(2)</sup>	550 <sup>(5)</sup>	547 <sup>(4)</sup>	550 <sup>(2)</sup>	550 <sup>(7)</sup>
8/Block 1	550 <sup>(8)</sup>	550 <sup>(6)</sup>	550 <sup>(6)</sup>	553 <sup>(1)</sup>	550 <sup>(5)</sup>	550 <sup>(1)</sup>
1/Block 2	556 <sup>(1)</sup>	558 <sup>(1)</sup>	556 <sup>(3)</sup>	556 <sup>(4)</sup>	556 <sup>(8)</sup>	558 <sup>(5)</sup>
2/Block 2	558 <sup>(7)</sup>	558 <sup>(4)</sup>	561 <sup>(6)</sup>	558 <sup>(2)</sup>	558 <sup>(3)</sup>	561 <sup>(2)</sup>
3/Block 2	500 <sup>(3)</sup>	497 <sup>(3)</sup>	497 <sup>(7)</sup>	500 <sup>(5)</sup>	500 <sup>(5)</sup>	497 <sup>(4)</sup>
4/Block 2	508 <sup>(8)</sup>	503 <sup>(2)</sup>	508 <sup>(8)</sup>	503 <sup>(3)</sup>	508 <sup>(2)</sup>	503 <sup>(3)</sup>
5/Block 2	550 <sup>(5)</sup>	556 <sup>(6)</sup>	550 <sup>(1)</sup>	550 <sup>(1)</sup>	550 <sup>(4)</sup>	550 <sup>(6)</sup>
6/Block 2	564 <sup>(4)</sup>	558 <sup>(5)</sup>	558 <sup>(4)</sup>	564 <sup>(8)</sup>	558 <sup>(7)</sup>	564 <sup>(7)</sup>
7/Block 2	497 <sup>(2)</sup>	500 <sup>(7)</sup>	500 <sup>(5)</sup>	497 <sup>(7)</sup>	500 <sup>(6)</sup>	497 <sup>(8)</sup>
8/Block 2	506 <sup>(6)</sup>	506 <sup>(8)</sup>	503 <sup>(2)</sup>	503 <sup>(6)</sup>	503 <sup>(1)</sup>	503 <sup>(1)</sup>

**Table 5.** Hardness results (Brinell Hardness)

Factors significance was tested at a 95% confidence level ( $p < 0.05$ ). This analysis was carried out separately so that factors significance for each response of studied mechanical properties could be verified, as shown in Tables 6, 7 and 8.

Terms	Effect	Coefficient	T	p
Constant		1955.29	1782.89	0.000
(D)	165.62	82.81	80.09	0.000
(A)	17.42	8.71	7.94	0.000
(B)	-198.54	-99.27	-90.52	0.000
(C)	-8.04	-4.02	-3.67	0.000
(A)(B)	-0.54	-0.27	-0.25	0.805
(A)(C)	5.62	2.81	2.56	0.012
(B)(C)	14.08	7.04	6.42	0.000
(A)(B)(C)	-6.25	-3.13	-2.85	0.005

**Table 6.** Significance test for resistance limit, by means of the Minitab Statistical Software (in MPa)

By means of the significance test performed for the mechanical property called tensile strength (shown in Table 6), it was found that the significant factors (where  $p < 0.05$ ) are: wire diameter (represented by letter D and tested by means of Blocks), speed (represented by letter A), lead temperature (represented by letter B), polymer concentration (represented by letter C), second order interactions among speed and polymer concentration, polymer concentration and temperature and a third-order interaction among speed, lead temperature and polymer concentration.

Terms	Effect	Coefficient	T	p
Constant		49.458	201.94	0.000
(D)	9.426	4.713	201.94	0.000
(A)	-2.750	-1.375	-5.61	0.000
(B)	3.583	1.792	7.32	0.000
(C)	1.750	0.875	3.57	0.001
(A)(B)	1.250	0.625	2.55	0.012
(A)(C)	-1.667	-0.833	-3.40	0.001
(B)(C)	-2.250	-1.125	-4.59	0.000
(A)(B)(C)	1.667	0.833	3.40	0.001

**Table 7.** Significance test for yield, by means of the Minitab Statistical Software (in percentage)

When analyzing the significance test for the mechanical property Yield (shown in Table 7), it is possible to note that the influential factors (where  $p < 0.05$ ) are: wire diameter (tested by blocks), speed, lead temperature, polymer concentration, second order interactions among speed and lead temperature, speed and polymer concentration, temperature and polymer concentration and a third-order interaction among speed, lead temperature and polymer concentration.

Terms	Effect	Coefficient	T	p
Constant		552.09	1650.05	0.000
(D)	46.86	23.43	74.26	0.000
(A)	4.85	2.43	7.25	0.000
(B)	-55.81	-27.91	-83.40	0.000
(C)	-2.19	-1.09	-3.27	0.001
(A)(B)	0.10	0.05	0.16	0.877
(A)(C)	1.65	0.82	2.46	0.016
(B)(C)	4.06	2.03	6.07	0.000
(A)(B)(C)	-2.35	-1.18	-3.52	0.001

**Table 8.** Significance test for hardness, by means of the Minitab Statistical Software (in BH)

Analyzing the significance test for hardness mechanical property (displayed in Table 8), it is possible to state that the influential factors (in which  $p < 0.05$ ) are: wire diameter (tested by means of blocks), speed, lead temperature, polymer concentration, second order interactions among speed and polymer concentration, temperature and polymer concentration and a third-order interaction between lead temperature and polymer concentration.

#### 4.2. Statistical modeling for multiple responses

Using coefficients calculated using the significance test, by means of the Minitab Statistical Software, it was possible to build statistical models which represent the relationship between process input variables (factors) and output variables (mechanical properties). Such statistical models are defined in equations 7, 8 and 9.

$$RL = 1955.29 + 82.81(D) + 8.71(A) - 99.27(B) - 4.02(C) + 2.81(A)(C) + 7.04(B)(C) - 3.13(A)(B)(C) \quad (7)$$

$$Y = 49.458 + 4.713(D) - 1.375(A) + 1.792(B) + 0.875(C) + 0.625(A)(B) - 0.833(A)(C) - 1.125(B)(C) + 0.833(A)(B)(C) \quad (8)$$

$$H = 552.09 + 23.43(D) + 2.43(A) - 27.91(B) - 1.09(C) + 0.82(A)(C) + 2.03(B)(C) - 1.18(A)(B)(C) \quad (9)$$

Where:

- RL: corresponds to the response variable called tensile strength;
- Y: corresponds to the variable called yield response;
- H: corresponds to the response variable called Hardness.

#### 4.3. Application of *desirability* function for optimization

For process optimization by means of desirability function, firstly, it was necessary to formulate the specifications required for the studied mechanical properties. To this, blocks were analyzed separately, that is, the response variables were optimized primarily for the wire diameter 2.00 mm and then the same procedure was carried out to diameter 6.5 mm.

Specifications (minimum, nominal and maximum) concerning the diameter the 2.00 mm diameter are presented in Table 9. In that case, one seeks nominal values (target) for mechanical properties such as traction resistance limit and hardness and, for the mechanical property called yield, one seeks to maximization, for the higher the value, the better the product itself.

The composite desirability (D) is the overall index calculated from combination of each response variables processed through a geometric mean and this index is responsible for showing the best condition to optimize all responses variables at the same time. To obtain the highest possible value for D, which reflects in the best condition of response variables in relation to their specifications care (displayed in Figure 2), the best adjustments using factors reduced variables [-1 to 1] are:

Tensile strength (MPa)			Yield (%)			Hardness (BH)		
Minimum	Nominal (target)	Maximum	Minimum	Nominal	Maximum (target)	Minimum	Nominal (target)	Maximum
1930	2040	2150	40	45	≥ 50	545	572	600

**Table 9.** Specifications for 2.00 mm gauge

- Speed, fit in -1.0;
- Lead temperature fit in -0.0909;
- Polymer concentration fit in 1.0.

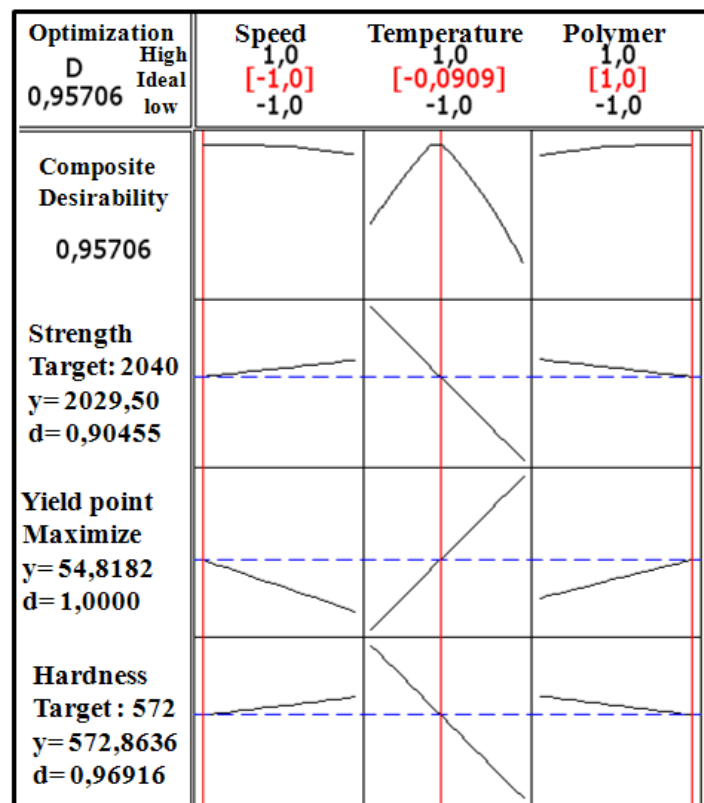

**Figure 2.** Desirability function applied in multiple responses (Minitab Statistical Software-2.00 mm diameter)

Looking at Figure 2, it can be seen that D value belonging to [0-1] interval, is maximized when all responses are close to their specifications, for the closer D is of 1, the closer the original responses will be of their respective specification limits. The optimal general point of the system is the optimum point achieved by geometric mean maximization calculated from individual desirability functions (d), which in this case are values for each one of response variables given below:

- For response variable called tensile strength,  $d=0.90455$ ;
- For response variable called yield,  $d=1.0$ ;
- For response variable called hardness,  $d=0.96916$ .

Values obtained for desirability (D) and individual desirability (d), show that the process was well optimized, since these indices are found to be very close to the optimum condition (1.0). Thus, it was possible to find that values obtained for this optimized condition are in accordance with required specifications and are:

- For tensile strength ( $y= 2029.5$  MPa);
- For yield ( $y= 54.8182$  %);
- For hardness ( $y= 572.8636$  BH).

By analyzing Figure 2, it was found that speed factor, when increased, also causes increased amounts of response variables tensile strength (MPa) and hardness (BH). Also, the increased speed affects yield response variable reduction (%) and desirability (D) composite reduction.

Regarding the lead temperature factor, with increasing temperature, one realizes values reduction of response variables tensile strength (MPa), Hardness (BH) and desirability composite (D). On the other hand, yield value increases (%).

By observing increase in polymer concentration factor, one can see that there will be decrease in response variables values called tensile strength (MPa) and hardness (BH), yield increase (%) and desirability composite (D).

In Table 10, it is shown specifications (minimum, nominal and maximum) relative to 6.50 mm diameter. Also one searches nominal values (target) for mechanical properties called tensile strength and hardness, and for mechanical property called yield, one seeks maximization.

Traction resistance limit (MPa)			Yield (%)			Hardness (BH)		
Minimum	Nominal (target)	Maximum	Minimum	Nominal	Maximum (target)	Minimum	Nominal (target)	Maximum
1770	1875	1980	40	48	$\geq 56$	500	530	560

**Table 10.** Specifications for 6.50 mm gauge

As shown in Figure 3, for obtaining the highest possible value for *desirability* composite (D), the best factors adjustments are:

- Speed, fit at -1.0;
- Lead temperature, fit at -0.1919;
- Polymer concentration, fit at 1.0.

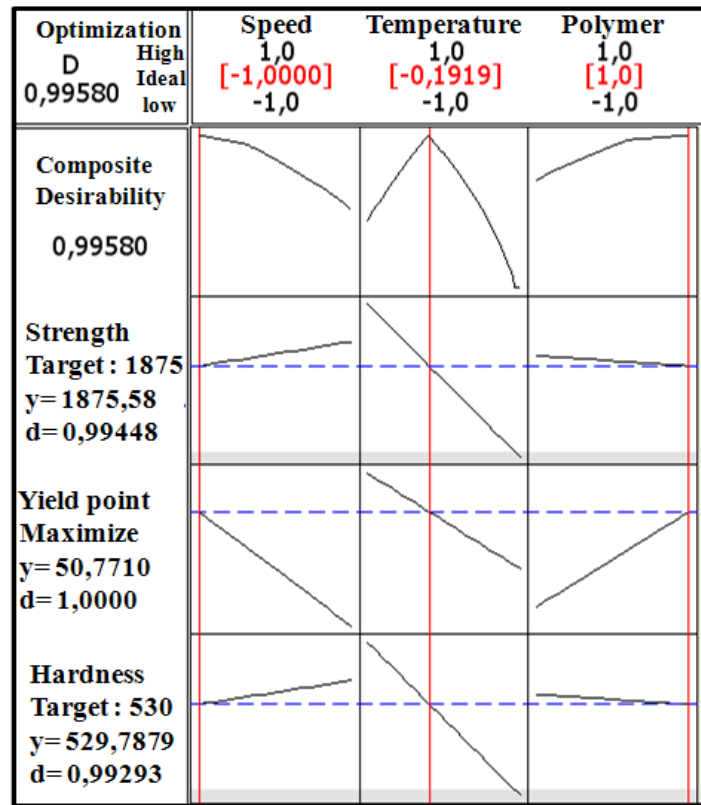

**Figure 3.** Desirability function applied in multiple responses (Minitab Statistical Software- 6.50 mm diameter)

By Figure 3 analysis, it is possible to realize that:

- For response variable called tensile strength,  $d=0.99448$ ;
- For response variable called yield,  $d=1.0$ ;
- For response variable called Hardness,  $d=0.99293$ .

It is also possible to observe that values obtained for this optimized condition comply with required specifications, which are:

- For tensile strength, (y= 1875.5791 MPa);
- For yield, (y= 50.7710 %);
- For hardness, (y= 529.7879 BH);

Regarding the speed factor, by increasing the speed one obtains values increase of response variable called tensile strength (MPa) and hardness (BH). Also, with increasing speed factor, it is observed a response variable reduction called yield (%) and desirability composite reduction (D).

Regarding the lead temperature factor, the increase means that there is all response variables decrease, including the desirability composite (D). By observing the polymer concentration factor, it is found that the increase will cause decrease of response variables tensile strength and hardness, increasing yield and desirability composite (D).

The red line (vertical) contained in Figure 3, can be interpreted as follows: in case it is moved, it will change the response values, and this will directly affect the composite desirability (D) values and individual desirability (d). For instance, by moving the red line, contained in the space relative to the lead temperature factor to the right, it will provide drop in the desirability composite (D), and all response variables (shown in Figure 3). It is possible to realize the drop in desirability composite (D) by observing the slope of straight contained in the location indicated previously. This decrease in D would represent optimization reduction of multiple responses and consequently no use of responses at their best factors adjustment conditions.

## 5. Conclusions

The design of experiments methodology with analysis in blocks applied to quench hardening and tempering process in SAE 9254 drawn steel wires with 2.00 mm and 6.50 mm diameters provided a wide understanding of factors influence in mechanical properties called tensile strength, hardness and yield.

By means of significance test (through of the Minitab Statistical Software), it was possible to find that factors such as diameter, speed, tempering temperature and polymer concentration have a significant influence on the studied mechanical properties and by statistical methods application it was possible to model the process, obtaining the best factors adjustment condition, which in turn, provided simultaneously multiple responses optimization.

Through the findings generated by this study, one seeks to fit in a planned way the quench hardening furnace set-up in a productive environment, obtaining, this way, reduction of initial laboratory tests amount and waiting time of these results, whose cost impacts directly the company financial indicators.

### Author details

Cristie Diego Pimenta<sup>1</sup>, Messias Borges Silva<sup>1</sup>, Rosinei Batista Ribeiro<sup>2</sup>, Roberto Campos Leoni<sup>1</sup>, Ricardo Batista Penteadó<sup>1</sup>, Fabrício Maciel Gomes<sup>1</sup> and Valério Antonio Pamplona Salomon<sup>1</sup>

\*Address all correspondence to: pimentadiego@yahoo.com

1 FEG UNESP – SP / Brasil, Guaratinguetá-SP, Brasil

2 FATEA – SP / Brasil, Lorena – SP, Brasil

## References

- [1] Benyounis, K. Y, & Olabi, A. G. Optimization of different welding processes using statistical and numerical approaches- A reference guide, *Science Direct*, (2008). , 39, 483-496.
- [2] Callister, J. R. W. D. *Uma introdução a engenharia e a ciências dos materiais*, 5ª edição, editora LTC, (2002). , 589.
- [3] Derringer, G, & Suich, R. Simultaneous Optimization of Several Response Variables, *Journal of Quality Technology*, n 4, (1980). , 12, 214-219.
- [4] Granato, D, Branco, G. F, & Calado, V. M. A. Experimental design and application of response surface methodology for process modeling and optimization: A review, *Food Research International*, (2011). , 1, 0-14.
- [5] Lima, V. B. S, Balestrassi, P. P, & Paiva, A. P. Otimização do desempenho de amplificadores de radio frequência banda larga: uma abordagem experimental, *Produção*, n. 1, jan/mar, (2011). , 21, 118-131.
- [6] Mayers, A. M, & Chawla, K. K. *Princípios de metalurgia mecânica*, 2ª edição, Edgard Blucher, (1982). p.
- [7] Montgomery, C. D. *Design and analysis of experiments*, 7<sup>th</sup> edition, John Wiley & Sons, (2010). p.
- [8] Montgomery, D. C, & Runger, G. C. *Estatística aplicada e probabilidade para engenheiros*, 2ª edição, editora LTC, (2003). p., 2003, 230-320.
- [9] Paiva, E. J. *Otimização de Manufatura com Múltiplas Respostas baseadas em índices de capacidade*, Dissertação, Universidade Federal de Itajubá, (2008). p.
- [10] Silva, H. A, & Silva, M. B. Aplicação de um projeto de Experiments (DOE) na soldagem de tubos de zircaloy-4; *Produção & Engenharia*, n. 1, set./dez. (2008). , 1, 41-52.
- [11] Wang, J, & Wan, W. Application of desirability function based on neural network for optimizing biohydrogen production process, *international journal o f hydrogen energy*, (2009). , 34, 1253-1259.
- [12] Wu, F. C. optimization of correlated multiple quality characteristics using desirability function. *Quality engineering*, n 1, (2005). , 17, 119-126.



