

We are IntechOpen, the world's leading publisher of Open Access books Built by scientists, for scientists

4,800

Open access books available

122,000

International authors and editors

135M

Downloads

Our authors are among the

154

Countries delivered to

TOP 1%

most cited scientists

12.2%

Contributors from top 500 universities



WEB OF SCIENCE™

Selection of our books indexed in the Book Citation Index
in Web of Science™ Core Collection (BKCI)

Interested in publishing with us?
Contact book.department@intechopen.com

Numbers displayed above are based on latest data collected.

For more information visit www.intechopen.com



Physicochemical and Radiation Modification of Titanium Alloys Structure

Kanat M. Mukashev and Farid F. Umarov

Additional information is available at the end of the chapter

<http://dx.doi.org/10.5772/55485>

1. Introduction

Intense development of science and technology with ever-increasing needs in new materials with the unique properties requires implementation of careful research in this area. Development and production of new types of materials is always related to the enormous costs and solving new technical problems of analytical and experimental nature. Recently a large class of the model alloys on metallic base, which meets various demands, has been created. A special place among them is occupied by the metals and alloys that undergo phase transformations. The requirements for the radiation resistance of these materials are of extraordinary importance. Investigation of the fundamental properties of materials that determine their physical, chemical, mechanical, technological, operational and other characteristics enables one to establish a field of their rational application with maximal efficiency.

The attention of the researchers should be drawn to investigation of the structure transformations in crystals, especially, their electronic and defect structure as well as their role in the process of formation of the material's final physical properties. Almost all of the material's properties are related to its electronic structure, and the constancy of the structure under external exposure determines stability of the main characteristics and can serve as a principal indicator of materials radiation resistance.

The problems of nuclear and thermonuclear power pose an urgent demand on continuous and wide range investigation of interaction processes of nuclear radiation with metallic materials, along with subsequent modification of their structure. For authentic establishing of common regularities of the observed phenomena, deep understanding of the processes of nucleation, formation and subsequent evolution and modification of the metals and alloys defect structure is crucial.

In spite of considerable amount of realized investigations, the analysis of the obtained results justifies the following findings: by the time of preparation of this work, the lack of the systematic information was experienced about the character of the radiation damageability of some perspective constructional refractory metals and their alloys, which firstly undergo polymorphous or phase transformations; influence of the type and concentration of alloying elements on the character of the structural disturbances at plastic deformation and radiation exposure in conditions of vacancy and vacancy-impurity complexes formation, packing defects, dislocation loops subject to material history, fluence, energy, flux, nature of ionizing radiation, temperature of irradiation and postradiational annealing.

There was no a thorough research of the influence of preliminary thermochemical treatment, including hydrogen and other atomic gases saturation and cyclic thermal shocks with an account of reconstruction of electron structure and density of pulse distribution of electrons in the field of defect production on the materials' final properties. Availability of such data would complete a full picture of purposeful properties changes and make possible working the materials with predetermined properties. This problem definition caused by demands of the state-of-the-art science and technology appears to be strategically important area of research in the fields of physics of metals, physics of radiation damage and radiative study of materials.

Therefore, the main goal of the present work, which is based on the authors' own research, is investigation and establishment of regularities of the electron structure alteration and its correlation with different titanium alloys crystal lattice defects created as a result of deformation radiation and complex thermochemical treatment.

2. Experimental and software-supported investigations

Since science of metals is generally experimental science, the depth, objectivity and reliability of our understanding of investigated phenomena related to materials electronic and defect structure are determined by capacity of the technical means and methods of investigation used in order to solve the problem.

The method of positron spectroscopy is the most important instrument of investigation in this case. Not only did the relativistic quantum mechanical theory developed by Dirac (1928) explain the main properties of electron and obtain the right values of its spin and magnetic moment, but also it determined the positron existence probability. Positron is the antiparticle of electron with the mass $m_{e^+} = m_{e^-} = 9.1 \cdot 10^{-28}$ g same as electron's, rest energy $m_0 c^2 = 0.511$ MeV and elemental, but opposite in sign, electron charge $e = 1.6 \cdot 10^{-19}$ K and spin $S = 1/2h$.

Natural positron sources normally do not exist. Therefore positrons are usually obtained from nuclear reactions in different nuclear power plants. The principal criteria for choosing positron sources are the cost and half-life period. The most widespread is the sodium isotope ^{22}Na obtained from ^{25}Mg by reaction (p, α) . It is convenient in all respects and easy-to-use in the positron spectroscopy experiments, as well as for angular distributions measurements, Doppler broadening of annihilation line, positrons life time and counting rate of 3γ – coinci-

dence. ^{22}Na nuclear decay occurs by the following scheme: $^{22}_{11}\text{Na} \rightarrow ^{22}_{10}\text{Ne} + e^+ + \gamma_{\text{Я}}$. In this nuclear decay reaction the ^{22}Na nuclear is produced in an excited state with the time of life less than 10^{-12} s. At the return to the ground state it emits the nuclear quantum with energy $E=1.28$ MeV, which effectively testifies positron production.

The essence of using positrons for solid structure probing is explained in the following. A positron emitted by a source while penetrating in solid to a certain depth subject to energy, experiences numerous collisions with the atoms of the solid, and consequently this positron gradually loses its velocity and at the end gains energy that corresponds to environment's absolute temperature: $E_0 = kT=0.025$ eV, where k is the Boltzmann constant. This process is referred to as the positron thermolysis. The fundamental result of this phenomenon is the positron thermalization time, during which the positron dissipates its initial energy. Its calculated value is $3 \cdot 10^{-12}$ s. [1].

Positron thermolysis process occurs during the time, which is considerably shorter than its life time before annihilation. This circumstance serves as grounds for using positrons in order to study the properties of condensed matters, because the conduction electrons, with which positron interacts, occupy the energetic band of the range of several electron-volt and more importantly positron does not contribute to the total pulse and energy of the pair and hence can be neglected. Therefore, the information, which is carried by the positron annihilation photons, corresponds to solid electrons state, in which positron's thermolysis and interaction and annihilation processes have occurred.

Annihilation is the act of mutual destruction of a particle and its appropriate antiparticle. While no absolute destruction of either matter or energy occurs, instead there is a mutual transformation of particles and energy transitions from one form to another.

Due to the law of charge parity a positron in singlet state ($1S_0$) decays with emission of even number (usually two) gamma-ray quanta. A positron in triplet state annihilates with emission of odd number (usually three) photons. The probability of the 3γ - process is lower by more than two orders than the probability of the 2γ - process. Therefore, all basic research that is oriented towards studying properties of condensed state properties is performed around this phenomenon.

If an annihilation pair is found in the state of rest in center-of-mass system ($v=0$), then in laboratory system of coordinates two photons would be emitted strictly in opposite directions at $\sin\theta=0$ (Fig.1a). As a result of interaction with the medium's electrons and phonons, positron completely thermalizes and in essence is in state of rest. However, we cannot state the same about electron, the other immediate participant of the annihilation process. At the same time pulse transverse component leads to deflection of γ_1 and γ_2 photons from collinearity:

$$P_z = m_0 c \theta_z; \quad (1)$$

This circumstance is initiating development of the method of measuring angular distribution of annihilated photons (ADAP). The purpose of the method is to obtain information about electrons

distribution function in momentum space. To this effect, it is supposed that length of the detector (ℓ), which registers the annihilated photons, must be much longer than its width (δ), and substantially smaller than distance (L) from positron source to detector. These facts correspond to so-called long-slot geometry of experiment, which is schematically represented in Fig. 1a.

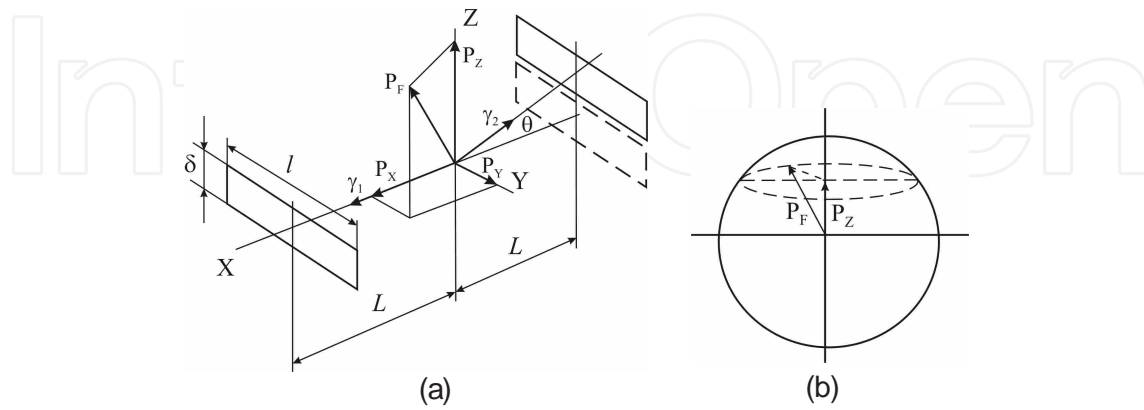

Figure 1. Line and slot geometry circuit with pulse decomposition e^-e^+ - pair on components (a) and Fermi surface cross-section for gas of free electrons (b)

At rest positron the impulse of annihilated photons is defined by electron impulse. The latter is uniformly distributed on whole Fermi sphere for ideal gas of electrons [2,3]. Therefore, ADAP measuring boils down to choosing thin sphere layer on distance P_z from its center located perpendicularly of this component of impulse (Fig. 1b). In this case angular correlation spectrum $N(\theta)$ must be of shape of reverse parabola, which mathematically can be described by the following equation:

$$N_p(\theta) = N(0)(\theta_F^2 - \theta^2) \text{ for } \theta \leq \theta_F \tag{2}$$

This distribution vanishes outside θ_F and this area corresponds to the boundary Fermi momentum $P_F = m_0 c \theta_F$. Besides the parabolic component the spectrum also contains a wide angular component caused by positrons annihilation with inner electrons of ion core with the impulse that considerably exceeds the Fermi momentum. The regularities of positron annihilation in this case have sufficiently reasonable description by Gaussian function:

$$N_g(\theta) = N_g(0) \exp\left(-\frac{\theta^2}{\theta_g}\right), \tag{3}$$

where θ_g is a Gaussian parameter and determines the penetration depth of positron's wave functions into the ion core. Hence, the ADAP general curve for any materials can be presented as the following:

$$N(\theta) = N_p(0)(\theta_F^2 - \theta^2)f(\theta) + N_g(0)\exp(-\theta^2 / \theta_g) + N_0 \quad (4)$$

The normalizing factor $f(\theta)$ in this equation takes only the following values:

$$f(\theta) = \begin{cases} 1 & \text{if } |\theta| \leq |\theta_F| \\ 0 & \text{if } |\theta| > |\theta_F| \end{cases} \quad (5)$$

The constant factors $N_p(0)$, $N_g(0)$ and N_0 in equation (4) define the intensity of the Gaussian parabola at $\theta=0$ and the background level of random coincidence, respectively. Besides the angular distribution there also exist other characteristics, which describe the regularities of electron-positron annihilation phenomena (EPA). The most important among them are the positron lifetime and Doppler broadening of annihilation line (DBAL). The logical interrelation of these three methods of positron annihilation is schematically depicted in Fig.2

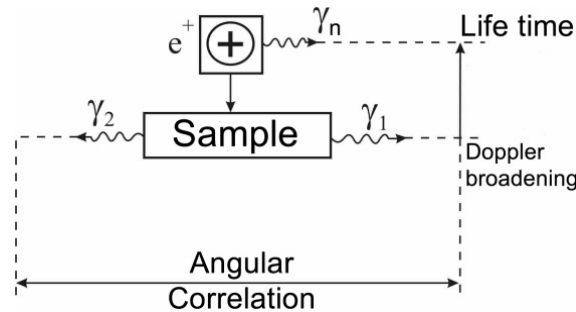

Figure 2. Schematic diagram of different methods of electron-positron annihilation (EPA)

The positrons annihilation process in solids can be described by a set of parameters. But, the most informative for material properties characteristics are those, which successfully fit into different physical regularities, i.e. those that carry in themselves one or another physical meaning. One of these parameters can be the values of probability of positrons annihilation with free and bound electrons. These parameters are derived from processing of experimental angular distributions spectra of annihilation emission (4). The area under each component (S_p , S_g) is usually defined by integration. Knowing the total area under the whole curve

$$S_0 = \int_{-\infty}^{+\infty} N(\theta)d\theta, \text{ we can calculate the positron annihilation probability with free electrons and}$$

electrons of ion core, respectively:

$$WP = SP / S_0, WG = Sg / S_0, \quad (6)$$

as well as the redistribution of positron annihilation probability between the free electrons and the electrons of ion core:

$$F = WP / WG = SP / Sg. \quad (7)$$

The example of decomposition of experimental spectra to components is shown in Fig. 3. Due to parabolic component spreading in the $\theta = \theta_F$ region, the Fermi angle value is usually determined by extrapolation.

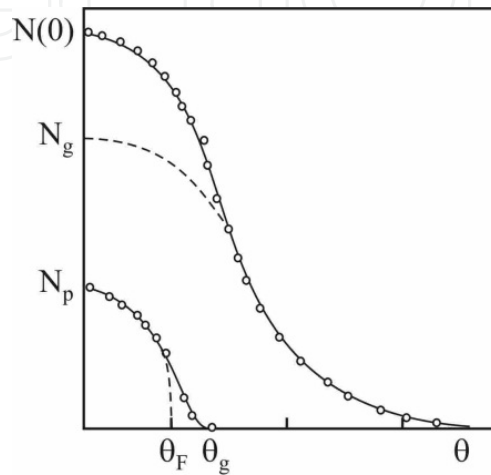

Figure 3. The decomposition of the angular correlation spectra into components

The changes in the investigated material structure are by all means reflected on the spectra form and lead to redistribution of positron annihilation probabilities. In this case after normalization to a single area, they can be built on one axis for comparison purposes (Fig. 4).

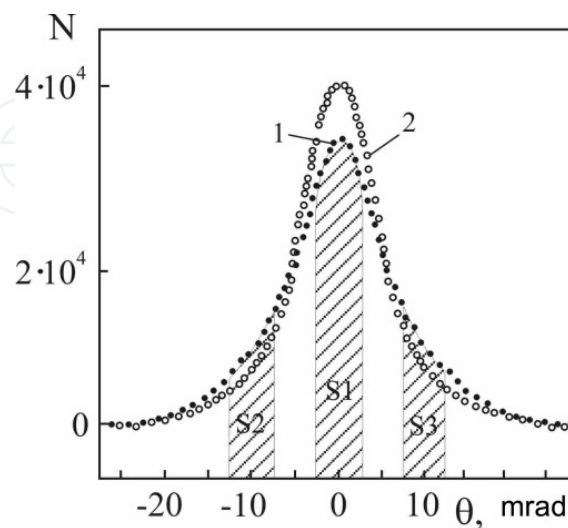

Figure 4. The APAD spectra normalized to a single area for annealed (1) and deformed (2) titanium

While comparing results of one set of measurements, which are related to thermal, deformative or radiative influences on the investigated materials, one can use a special configuration parameter sensible to the presence of only one kind of defect in the crystal [4]:

$$R_N = \left| \frac{N_V^t - N_V^f}{N_c^t - N_c^f} \right|, \quad (8)$$

where N is a counting rate value in the structurally sensitive region of the annihilated photons angular distribution spectrum; subscripts v and c of N refer to a positron annihilation with free and core electrons, respectively; superscripts t and f correspond to positron annihilation from the trapped and free states. It is assumed that this parameter does not depend on defects concentration in the material and is determined by its structure only.

The basic specifications of the experimental spectrometer of annihilated photons angular distributions with line and slot geometry are the following:

- Angular resolution of the setup changes within the range of 0.5–1.5 mrad.
- The time resolution on the fast channel equals to 100 ns and on the slow channel ranges within the interval of 0.3–1.0 μs.
- The movable detector step width is set stepwise by 0.25, 0.5 and 1.0 mrad; in all the setup permits to measure up to 50 values of coinciding gamma photons intensity in one direction from the spectrum maximum position.
- The counting rate instability in the course of three days of continuous work does not exceed two standard deviations.
- The allowed maximum intensity of incoming information on the slow channel is no worse than $3 \times 10^5 \text{ s}^{-1}$.
- The maximal vacuum in the measuring chamber is no worse than 10^{-4} Pa at the temperature of 300 – 1100 K.
- The positrons source activity of ^{22}Na is $3.7 \times 10^8 \text{ Bk}$ (10 mKi).

The reliability of positron investigations results depends on a number of reasons which are as far as possible taken into account during the process of experimental investigations.

The preparation of investigated objects of different composition was realized in the high temperature electroarc furnace on a copper bottom with nonexpendable electrodes. After batch charging and before alloying, a vacuum of $\sim 10^{-2} \text{ Pa}$ was created in the furnace. After that a high purity argon was introduced into the furnace, in which all the processes of melting were conducted in this atmosphere. For homogeneity, ingots were repeatedly melted (up to 5–6 times). The finished ingots were rolled at a temperature of 900°C up to 1–2mm strips and then annealed at 10^{-5} Pa vacuum at 900 °C during 2 hours. The annealed samples were prepared from 1mm strips, which repeatedly underwent plastic deformation ($\varepsilon = 50\%$) by rolling at room

temperature. The true content of the components in the check samples of the material was determined by chemical and spectral analysis methods. Then the surfaces of these samples were thoroughly burnished, and the samples were polished electrochemically in the solution of the following composition: HF – one part, HNO₃ – three parts and H₂O – two parts. The prepared samples were flushed with flowing water and wiped with alcohol. The temperature measurement of samples at irradiation and annealing was performed by thermometry methods. All measurement processes of annihilation characteristics of investigated materials after different kinds of influences (plastic deformation, radiative and other complex physico-chemical and thermal treatments) were conducted at room temperature.

2. Modification of titanium alloys defect structure by plastic deformation method

The progress of modern engineering and technology is closely related to the achievements in science of metals, which before taking a specified form and properties usually undergo plastic deformation. Not only is the deformation process one of the effective methods for giving the required form to a material but it is also an important means for modifying its structure and properties. Yet defect formation and defects influence on metals physico-mechanical properties is one of the important problems in metal physics. For investigation of modification processes in metals structures the titanium binary alloys, alloyed with Zr, Al, Sn, V, Ge and In within the range of solid solution, were prepared. The elements content in alloys was defined more precisely by chemical and spectral analysis.

Zirconium Zr is an analog of Ti and forms with it a substitutional solid solution of complete solubility. As far as concentration of Zr is increased the temperature of the allotropic transformation of Ti slightly drops and reaches the minimum at equiatomic ratio (50 at.% and 545°C). Thus, Zr is a weak β -stabilizer for Ti. Usually β -phase is not preserved in this system at the room temperature. Al is a substitutional element for Ti with limited solubility in α - and β -phase at presence of peritectoid breakup of the β -solid solution. The Ti-Al system plays the same role as the Fe-C system for steels in physical metallurgy.

While alloying Ti by Sn, the eutectic systems are formed. Sn forms the system with limited solubility of alloying elements at presence of the eutectic breakup of β -solid solution. Sn considerably differs from Ti by its properties and it is restrictedly soluble in both Ti modifications. Ti-In is one of those systems that are most insufficiently explored due to considerable difficulties related to preparation of alloys. In slightly reduces the temperature of alloy polymorphic transformation and is therefore a weak β -stabilizer.

When alloying titanium with vanadium a solid solution in β -Ti is formed, with complete solubility. Ti-V phase diagram strongly depends on the method of obtaining Ti (iodide, hydride-calcic or magnesium-thermic). The V solubility in α -Ti at 650°C does not exceed 3.5 weight %. Alloying with V leads to Ti lattice spacing decrease, therefore the c/a ratio consecutively decreases with increase of V content in alloy.

2.1. Structural transformations in plastically deformed alloys of the Ti-Zr system

Influence of plastic deformation on the structural damages formation was investigated on the alloys that contained 0; 2.7; 8.3; 17.0; 22.0 and 39.0 at.% Zr. Plastic deformation $\varepsilon = 50\%$ considerably changes shape of the curves by decreasing width on the half height (FWHM) and increase of counting rate at maximum of $N(0)$ relative to the initial (annealed) state, which is the effect of crystal structure defects occurrence in the material (Fig.4). For interpretation of investigation results the above mentioned annihilation parameters $F=S_p/S_g$, $\theta_F=P_F/mc$ and their relative changes ΔF and $\Delta\theta_F$ were used.

In order to establish regularities of changes of annihilation parameters depending on the structure damages level, Ti and its alloy Ti – 2.7 at.% Zr underwent plastic deformation by different degrees in the range from $\varepsilon = 5$ up to 80 %. It is determined that main changes of the annihilation parameter occur when ε takes values up to 30%, whereupon it reaches saturation. Though for Ti–2.7 at.% Zr alloy it reaches saturation considerably quicker than for pure Ti (Fig. 5). Evidently it can be stated that with an increase of deformation degree the defects concentration in metals also increases and at certain level virtually all positrons are captured and annihilated in defects. In such state the annihilation parameters are typical for deformation defects. In other words, in the conditions of ultimate strains the EPA characteristics contain information about structure of the crystal regions, in which the vast majority of positrons annihilation occurs.

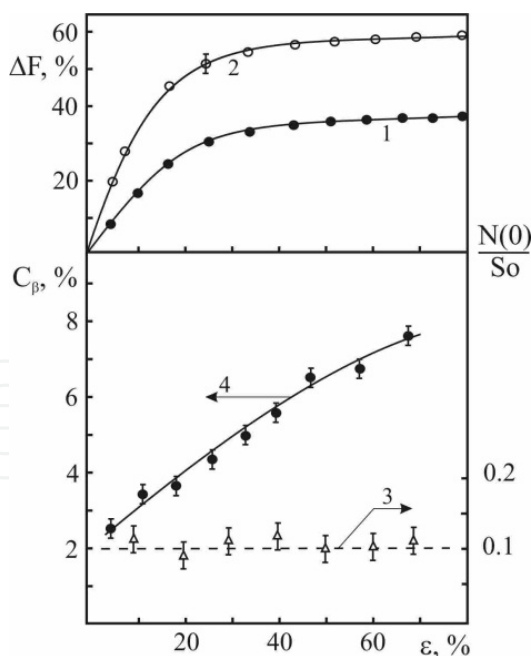

Figure 5. The influence of deformation degree and alloying element concentration on titanium alloys structural-sensitive characteristics: 1-Ti; 2- Ti-2.7 at.% Zr; 3- $N(0)/S_0$ relationship; 4- the β -phase content in alloy

In order to determine the phase composition, titanium and Ti–2.7at.% Zr alloy underwent X-ray analysis using the DRON-2 diffractometer in the filtered CuK_α radiation with the help of

the special methods of accuracy enhancement. Then the β -phase concentration in the lattice structure can be determined by the equation [5]:

$$C_{\beta} = \frac{100\%}{1 + 2.33(I_{\alpha} / I_{\beta})}, \quad (9)$$

where I_{α} and I_{β} are X-ray radiation integral intensity for α - and β -phases of the alloy, respectively. It has been established that the cold deformed Ti at any deformation degrees has only a single-phase structure. Also after plastic deformation in the alloy there is a two-phase $\alpha+\beta$ microstructure is observed, where the β -phase content changes monotonically with the deformation degree (Table 1 and Fig.5).

E (%)	0	5	10	20	30	40	50	60	70	80
C_{β} (%)	-	2,66	3,61	3,76	4,85	5,90	6,96	7,25	8,05	8,77

Accuracy $\pm 0,05$

Table 1. The β -phase content in Ti-2.7at.% Zr alloy

Hence, one can do the following conclusion. For those alloys that undergo transformation, plastic deformation at room temperature initiates phase transformation since energy rise in the crystal introduced by the defects may thereby decrease. In this case, the boundary with matrix regions of new phase nucleus should be assumed as the most likely positrons capture centers.

In such metals as Ti and Zr, in which the phase transformations from HCP to BCC-structure occur at relatively low temperatures, the packing defect formation energy in prismatic plane must be small [6]. With this in mind one cannot help noticing the nature of dependence of the relative change $\Delta F = (F_{def} - F_{rel})/F_{rel}$ parameter on alloys composition (Fig.6).

The maximum changes ΔF are observed for alloys with 2.7 and 3.9 at.% Zr, while for other concentrations this value is significantly lower. By individual cases, possible role of other factors is indicated by this behavior of the parameter F ; one of such factors can be interaction of localized-in-defects positrons with lattice instability. In other words, it is pertaining to the different degrees of alloys lattice stability towards transformation initiation. It is evident that the maximum deviation of the parameter F related to Zr concentration nearly corresponds to the minimum value of the $\alpha \rightarrow \beta$ transformation temperature.

Experimentally obtained value of $\Delta\theta_F = (\theta_{\epsilon} - \theta_{F0})/\theta_{F0}$ parameter reaches $\sim 9,5\%$, which is higher by order of magnitude than expected. This testifies that the positrons are annihilated in the defect regions, in which electron density is significantly lower than in the matrix. Thus the most likely positrons capture centers in this case are the new phase regions on its boundaries with the matrix. The structure of these new phase regions differs by far from that of the matrix.

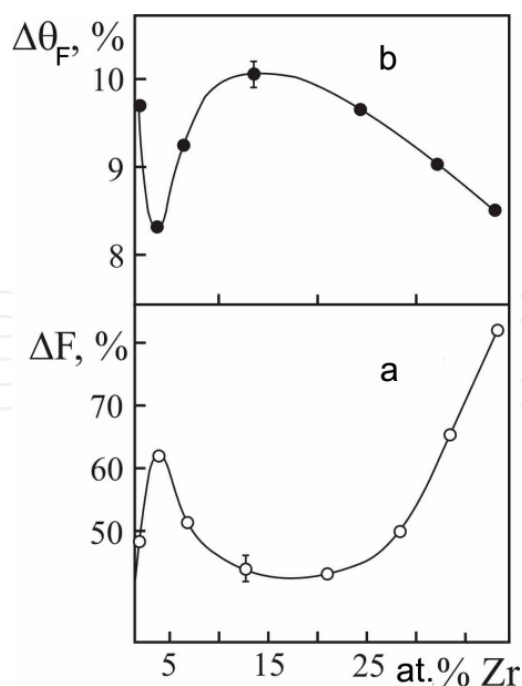

Figure 6. Concentration dependencies of annihilation characteristics for Ti-Zr system alloys.

Therefore, one should consider two main factors that are responsible for initiation of the polymorphic transformation in the Ti-Zr alloys: plastic deformation, which leads to the formation of packing defect with the BCC-phase structure in the HCP-phase matrix, and positron interaction with lattice instability. Separation of contribution pertaining to each factor to annihilation parameters change is as yet an impracticable problem for employed experiment conditions.

2.2. Structure modification in the Ti-Al and Ti-In alloys

In order to obtain additional information about the nature of positrons interaction with the structure damages in the plastically deformed metals the second group of binary titanium alloys was prepared. These alloys contain alloying elements from the III group of the periodic system, namely Al in concentrations 0; 5.2; 10.2; 12.5 and 16.5 at.%, and also In with concentrations 0; 1.4; 2.9; 5.1; 8.5 and 10.3 at.%. The maximum concentration of alloying element in each of these systems meets the requirements of mandatory occurrence of alloys in the solid solution region, where the chemical compounds formation is ruled out in advance.

All alloy samples with the specified concentrations of alloying elements were deformed by the cold rolling method by $\varepsilon = 50\%$. Concentration dependencies of the ΔF and $\Delta\theta_F$ annihilation parameters for the investigated materials are presented in Fig. 7. One can see that relative changes of the F parameter for these alloys are also considerable as in the previous case and reach 130% for Ti-5.2 Al alloy and 250% for Ti-1.4 In alloy. At the same time the Fermi angle decrease for the first case reaches $\Delta\theta = 17\%$ and 12.7% - for the second case. For Ti-In system the ΔF concentration dependence is of complex nature with two maximum points with In concentrations 1.4 and 7.4 at.%.

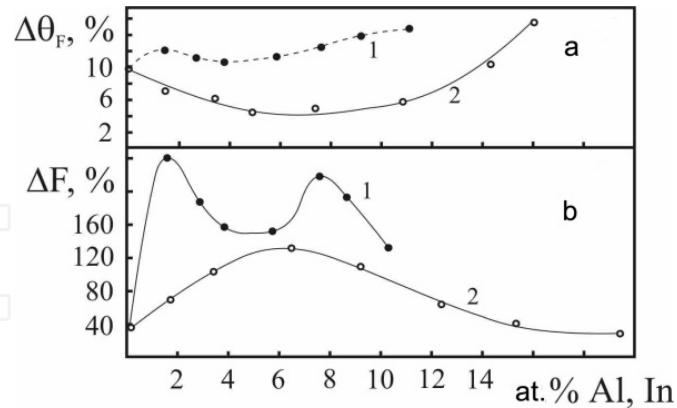

Figure 7. The concentration dependencies of annihilation parameters for Ti-In (1) and Ti-Al (2) deformed alloys systems.

If a strongly deformed alloy is to be considered as a two-phase system, then on the basis of positrons capture models one can define approximate bulk defect size therein: $R_V = 10 \text{ \AA}$. Therefore, one can assume that strong deformation of titanium alloys is accompanied, along with the new phase, by the formation of vacancy clusters and their aggregations, which can serve as deep potential wells for positrons.

2.3. Peculiarities of positrons annihilation in the deformed Ti-Sn alloys

These alloys contained the following concentrations of alloying element: 0; 1.2; 2.5; 4.3; 6.2 and 7.6 at.% Sn. All alloys were deformed by cold rolling by $\varepsilon = 50 \%$. The investigation results are presented in Fig.8. The observed changes of parameters in this case, as in the earlier one, are substantial and possess a complex nature dependent on alloy composition. Thus, the relative change of annihilation probability ΔF for Ti-1.2 at.% Sn alloy passes through maximum and reaches 135 % and then reaches minimum value ($\Delta F = 85 \%$) at the concentration of 6.2 at. % Sn. For comparison, in the case of Ti-Ge alloys system this factor also passes through maximum at the concentration of 0.8 at.% Ge, but with $\Delta F = 185 \%$.

One can make yet another observation which is typical for these alloys: the nature of change of the alloying elements parameters at small concentrations roughly coincide, whereas maximum decrease of the Fermi angle ($\Delta\theta_F = -17\%$) is detected for the Ti-1.5 at.% Ge alloy. In other words, it is facing a certain shift between maximum locations for two dependencies of one system of alloys.

Based on abnormally large changes of F and θ_F annihilation parameters one can make an assumption that the positrons capture centers structure conform to the regions with average electron density, which is considerably lower than for general vacancy-dislocation defects. Since the deformation causes a considerable increase of the parameter F with the respective decrease of the Fermi momentum, this indicates that with general decrease of average electron density in these defects the contribution of ion core electrons to the EPA process also decreases. This means that the annihilation occurs mainly with free electrons in the defects.

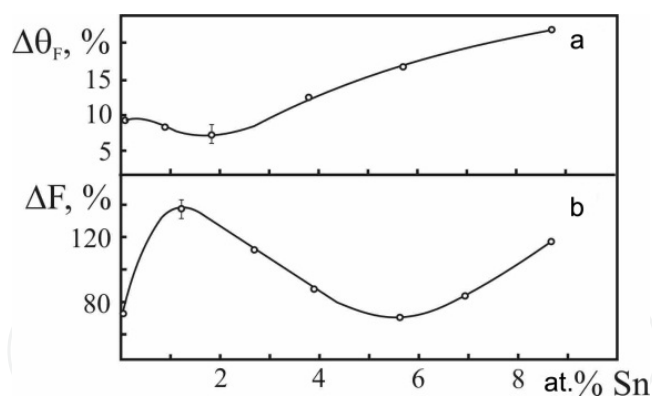

Figure 8. The concentration dependencies of annihilation parameters for Ti-Sn system.

On the basis of the findings related to studying Ti alloys one can state the following. For the deformed Ti alloys the sharply expressed anomalies are typical, which become even stronger with certain concentrations of the alloying elements and when the initial lattice is fully reconstructed as a result of considerable shortening of material interatomic distance. Consequently it is not possible for crystal lattice to preserve initial electron structure. Therefore, probably for the investigated Ti binary alloys we should adopt a concept of autonomy of d-electron matrix subsystem relative to the alloying elements interstitial atoms conduction band, when the wave functions of the matrix atoms d-electrons are overlapped with the wave functions of impurity atoms conduction electrons. The latter is probably correlated somehow with the lattice instability. With this in mind the largest lattice instability are displayed by the investigated Ti alloys systems that contain 1.2 at.% Sn, due to which the maximum change of ΔF annihilation parameter is observed.

2.4. Restoration of structure damages in plastically deformed titanium alloys

In many metals, the structure damages generated at low temperatures are usually “frozen”, which enables investigation of their spectrum by measuring some macroscopic properties of the crystal with its subsequent heating. Among the most applicable are the methods of residual electrical resistance measurement, crystalline lattice period measurement, X-ray line profile measurement, etc. For dislocation structure investigation, electron microscopic and neutron diffraction methods were most effective [7, 8].

The main task of investigating metals modified by cold deformation is the differentiation between effects that are related to the presence of the structure defects ensemble in them. These effects can be more or less successfully determined while investigating the processes of recovery and recrystallization of deformed metals by annealing. The most important structure imperfection annealing mechanisms are absorption of point defects by dislocations, mutual destruction of vacancy and interstitial atoms, breakup of point defects aggregations into individual one, etc. As a result of these mechanisms, while heating, the structure damages are partially or fully annealed in different temperature ranges. Eventually the annealing process can be interrupted after recrystallization, due to which full removal of the defect structure and the initial structure restoration is observed.

Of course, in the given temperature range more than one independent or concurrent processes can occur. Then the overall picture of annealing kinetics can be presented as superposition of separate individual processes each of which is responsible for a certain return mechanism. In addition, it appears to be impossible to avoid formation of the complexes, mobility of which can significantly differ from that of the single defects. The annealing kinetics of structure damages in metals, provided that there is one type of defects, can be described by following equation [9, 10]:

$$dP / dt = -\lambda_0 P^n = -A_0 P^n(t) \exp[-E_a / kT], \quad (10)$$

where $P(t)$ is the change of some material's physical property; T is absolute temperature. Here the activation energy of migration E_a is a typical sign of each of the defects type [11, 12]. If there are several active processes in the crystal then the search of the respective E_a values becomes complicated. At the same time the determination of the physical meaning of each value of E_a also becomes nontrivial. Therefore, it is often assumed that in the given narrow temperature range only one active process is running.

The essence of conducting the isochronal annealing by EPA method is based on the ADAP curve return for a defect material up to annealed state. As a result, the defects annealing states are usually established and the respective activation energy is defined by the following equation [13]:

$$E_a = kT_0 \ln(\nu \cdot k / \alpha E_a), \quad (11)$$

where $\nu \approx 10^{13} \text{s}^{-1}$ is a Debye frequency; $k = 8.62 \cdot 10^{-5} \text{eV/K}$ is the Boltzmann constant; T_0 is average temperature of annealing stage (K); $\alpha = \Delta(T^{-1}) / \Delta t$; $\Delta(T^{-1}) = T_I^{-1} - T_F^{-1}$; T_I and T_F are initial and final temperatures of the stage; Δt is annealing time at a given temperature (T).

The results of annealing investigations for titanium deformed by $\varepsilon = 50\%$ and 2.7 at.% Zr titanium alloy at different degree of deformation ($\varepsilon = 5, 10$ and 20%) are presented in Fig. 9 as isochronal annealing curves, which are shifted one relative to another by a constant value downward along the Y-coordinate. Isochronal annealing of iodide titanium is implemented in two steps. The first one is a low-temperature stage in the temperature range of 150-350°C, i.e. the recrystallization temperature threshold for this stage is 150°C. This stage, which has defects migration energy activation $E_{a1} = 1.35 \text{eV}$, corresponds to the vacancy complexes. The high-temperature stage is located between 350°C and 650°C with activation energy $E_{a2} = 1.9 \text{eV}$. It is obvious that in this stage the dislocation defects and the packing defects, as β -phase initiated by plastic deformation, are annealed.

The results of annealing of Ti-2.7 at. % Zr alloy, which was exposed to different degrees of deformation, seems more interesting. It is easy to see that the annealing curves shape for alloy considerably differs from those of Ti that verifies the appropriate role of the alloying element Zr. With an increase of the plastic deformation degree the temperature threshold of recrystal-

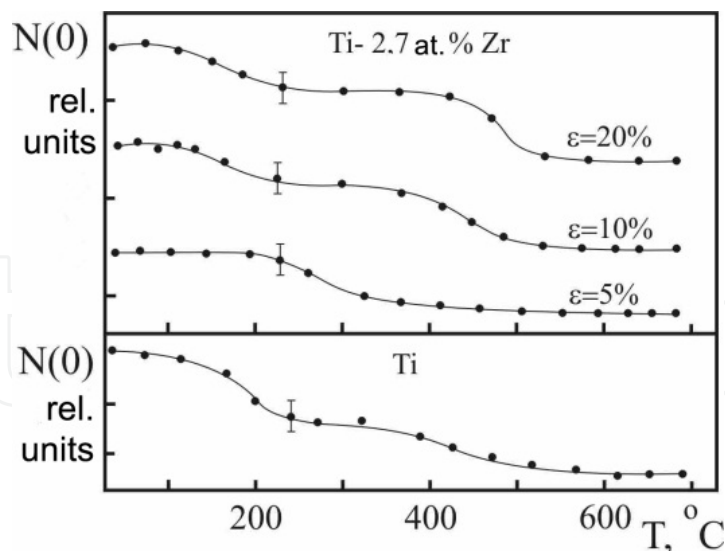

Figure 9. Annealing kinetics of Ti-Zr alloys

lization gradually shifts towards low temperature: from 200°C at $\varepsilon = 5\%$ down to 100°C at $\varepsilon = 20\%$. At the same time the I-stage part tends to increase depending on the deformation degree. This effectively confirms successive accumulation of vacancy defects. This stage with $E_{a1} = 1.65\text{--}1.75$ eV, evidently corresponds to vacancy and vacancy-impurity complexes. The II stage of annealing for this alloy tends to narrowing along with an increase of the deformation degree. All narrowing processes of the II stage are also accompanied by an increase of its relative level. Based on these results it can easily be established that it is Zr that serves as the β -phase initiating element. The given high-temperature stage, for which the migration activation energy occupies the interval of $E_{a2}=1.85\text{eV}$, probably corresponds to the dislocation and packing defects annealing with β -phase with split dislocations initiated by plastic deformation.

2.5. The structure modification of Ti-V alloys system as a source of packing defects

The positrons interaction with packing defects is of certain interest because some researchers tend to doubt that positrons can be captured by defects of this type [14]. Therefore, arrangement of special experiments with more precise methods for detecting the latter is the task of high importance. However, in order to ensure with the highest probability packing defects occurrence as a result of plastic deformation, the investigated titanium alloys have to be accordingly chosen. To this effect, the alloying elements must form a complete solubility of solid solution with titanium without eutectic and peritectic in the investigated concentration range of the second component with the successive decrease of the phase transformation temperature. In other words, the alloying element must be β -stabilizer.

Packing defects are a voluminous lesion. The objective of this research was to study packing defects by virtue of comparing X-ray structural analysis results with positron annihilation data. Based on the aforementioned, vanadium (V) was chosen as an alloying element, which is located in the Y-group of the periodic system. The energy of V packing defects formation is $v = 0.1$ J/m², that is five times greater than for Ti but considerably smaller than for other metals

of the transition group. V is a β -stabilizing substitutional element for Ti with the atomic diameter of 2,72Å. The V alloys with 0; 0.5; 1.5; 2.0; 4.0 and 5.8 at. % content were prepared by the technique described above. The plastic deformation by $\epsilon = 80\%$ was implemented by rolling at room temperature. $(10\bar{1}0)$, (0002) and $(10\bar{1}0)$ lines profiles were taken in the filtered $\text{CuK}\alpha$ radiation using the DRON-2 diffractometer. The packing defects formation on prismatic plane $\alpha_{(1010)}$ probability calculation results along with the annihilation parameters are summarized in Table 2.

Materials at. %	State		F	ΔF %	θ_F mrad	$\Delta\theta_F$ %
Ti	annealed	-	0.30	-	6.33	-
	$\epsilon=80\%$	$1.2 \cdot 10^{-3}$	0.44	46	5.83	7.9
Ti-0.5 V	annealed	-	0.28	-	6.36	-
	$\epsilon=80\%$	$4.2 \cdot 10^{-3}$	0.42	50	5.75	9.6
Ti-1.5 V	annealed	-	0.29	-	6.40	-
	$\epsilon=80\%$	$6.2 \cdot 10^{-3}$	0.39	35	5.83	8.9
Ti-2 V	annealed	-	0.23	-	6.40	-
	$\epsilon=80\%$	$7.7 \cdot 10^{-3}$	0.34	49	6.00	6.2
Ti-4.6 V	annealed	-	0.24	-	6.42	-
	$\epsilon=80\%$	$9.0 \cdot 10^{-3}$	0.35	44	6.08	5.3
Ti-5.8 V	annealed	-	0.28	-	6.29	-
	$\epsilon=80\%$	$10.2 \cdot 10^{-3}$	0.35	25	5.79	7.9
Accuracy \pm		0.001	0.01	2.0	0.05	0.1

Table 2. The packing defects probability and Ti-V alloys annihilation parameters

One can see that for all investigated alloys the plastic deformation leads to an increase of the parameter F by 25-50% with a simultaneous decrease of the Fermi angle θ_F by 5-10%. The changes of the annihilation parameters depending on the composition are of monotonous nature. The packing defects probability on the basal plane both for Ti and alloys remains practically without changes and equals $\alpha_{(0001)} = 2 \cdot 10^{-3}$, whereas on the prismatic plane (1010) the probability monotonically increases from $4.2 \cdot 10^{-3}$ up to $10.2 \cdot 10^{-3}$ depending on V concentration. Thus, the packing defects formation under plastic deformation in Ti – V alloys became an established fact and alloying with V only facilitates this.

The results of the isochronal annealing for deformed Ti, V and Ti – V alloys are presented in Fig. 10.

On the basis of stage II annealing results analysis one can notice that among the investigated materials the packing defects are most pronounced only in the alloy with 2 at.% V, which corresponds to the temperature range 350 - 720°C with $E_{a2} = 2.35\text{eV}$. For all other alloys this

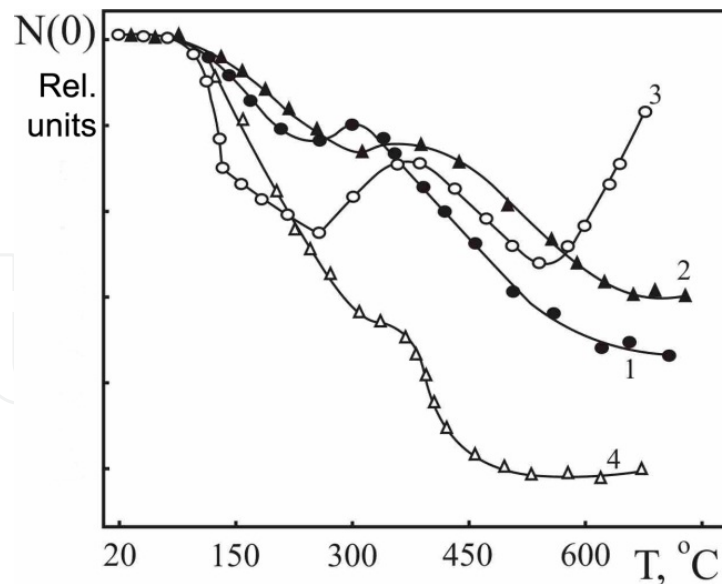

Figure 10. The concentration dependencies of annealing kinetics for deformed Ti-V alloys 1 – Ti; 2 – Ti – 2.0 at. %V; 3 – Ti – 4.6 at.%V; 4 – V

process is shaded by the bound vacancy-impurity complexes, which are caused by plastic deformation, and the impurity atoms atmosphere formation around packing defects.

3. Radiation modification of the titanium alloys properties

3.1. Problem statement

The study of positrons behavior in the plastically deformed metals showed high sensitivity and selectivity of the EPA method to the structure damages in these materials. Therefore it is natural that investigators tend to use this method to learn about radiation effects in solids as a result of nuclear irradiations of a material. This irradiation is accompanied by a number of new phenomena. The most important among them are nuclear reactions and related to them change in the elemental composition, point defects formation and crystal integrity disturbance, point defects aggregations occurrence and matrix disturbance caused by atomic collisions cascades, etc.

It is clear that without careful and detailed study of all aspects of nuclear radiation interaction with material and its consequences it is impossible to predict behavior of the materials in the field of strong ionizing radiation. The positron annihilation methods are promising and sufficiently informative for investigations of this kind.

As known, interaction of nuclear radiation with a material occurs by elastic and inelastic collisions channels. It is impossible to trace the process of radiation damage, which happens during 10^{-13} – 10^{-11} s. Therefore, using different experimental methods the final structure of radiation damaged material is usually studied, which is in the state of equilibrium with an environment. Consequently, investigation and control of construction materials radiation

damageability is the task of primary importance and, undoubtedly, attracts a considerable scientific and practical interest. Though, as of today there are practically no systematic, detailed and purposeful investigations of titanium and its alloys radiation properties. In this chapter the results of authors' own investigations in this field are thoroughly described.

3.2. The methodology of materials irradiation on accelerator and reactors

Reliable and reproducible results of the investigation of ionizing radiation influence on the solid can be obtained only under conditions of guaranteed high accuracy of measurement of irradiated target temperature. The final structure of the material is determined by the conditions of irradiation.

Since positron annihilation methods are mainly sensible to vacancy defects, in this case the problem was to preserve just this type of defects during the irradiation process of the investigated material. Taking into account these circumstances, the irradiation of the samples on the electron accelerator ELU-6 and isochronous accelerator U-150 was conducted in the air atmosphere with the water-cooled base and forced blow-off of the sample with liquid nitrogen vapor. With the charged particles intensity of $(1.5 - 2) \times 10^{16} \text{ m}^{-2} \text{ s}^{-1}$, the sample's temperature did not exceed 60–70°C.

The major portion of the reactor irradiation, related to investigation of neutron flux influence on metals, was implemented using the nuclear reactor VVR-K at the National Nuclear Centre of the Institute of Nuclear Physics of the Republic of Kazakhstan. The reactor's nominal power is 10MW. Energy distributions of the thermal and fast neutrons fluxes for irradiated channels were determined by the activation analysis method. For thermal neutrons cutoff the method of samples screening by cadmium was applied. After irradiation the materials were exposed to the chain of "hot chambers" where they undergo cutting and dosimetry control. The samples temperature in the irradiation process was taken to be equal to the temperature of the primary-coolant system heat carrier (+80°C).

3.3. Titanium structure modification as a result of electrons irradiation

As any other charged particles, while interacting with the crystalline lattice, the high energy electrons experience losses of energy on excitation, ionization and atoms displacement. For metals the first two electron interaction processes usually end without consequences. The consequences of elastic interactions depend on electron and recoil atom mass ratio as well as recoil energy E_p . If the recoil energy is greater than the defect formation threshold energy ($E_p > E_d$), then atom will leave its place in the lattice, which leads to formation of the elemental Frenkel pair, i.e. interstitial atom and vacancy. When E_p values are high the displacement cascades can appear and they consist of two or three vacancies and a certain number of interstitial atoms. The latter move towards the sinks or recombine with vacancies at the room temperature. Therefore, as a consequence of high energy electrons irradiation vacancy defect structure is generally formed in the crystal, which can be effectively studied by positrons diagnostics methods.

To this end, iodide titanium samples of high purity were irradiated by $E = 4\text{MeV}$ electrons with intensity of about $5 \cdot 10^{12} \text{ cm}^{-2}\text{s}^{-1}$ and up to $3.7 \cdot 10^{17}$; 10^{18} ; $3.7 \cdot 10^{18}$; 10^{19} and $3.7 \cdot 10^{19} \text{ cm}^{-2}$ fluencies

at a temperature lower than 70°C with the following ADAP spectra measurement and structure sensitive annihilation parameters determination. The results of these investigations are shown in Table 3. One can see that the positrons and conduction electrons annihilation relative probability practically grows in linear fashion with the fluence increase and rate of this growth decreases only at the last two fluence values: 10^{19} and $3.7 \cdot 10^{19} \text{ cm}^{-2}$. At the same time the Fermi momentum angle θ_F has a trend to stabilization at 5.70 mrad.

Fluence, cm^{-2}	F	θ_F , mrad.	R_c	E_a , eV
0	0.21	6.33	-	
$3.7 \cdot 10^{17}$	0.36	5.85	1.52	
10^{18}	0.40	5.75	1.55	1.23
$3.7 \cdot 10^{18}$	0.45	5.70	1.62	1.28
10^{19}	0.49	5.72	1.58	
$3.7 \cdot 10^{19}$	0.53	5.69	1.61	
Accuracy \pm	0.01	0.02	0.05	0.05

Table 3. The annihilation parameters dose dependence for titanium irradiated by electrons

If the positrons and conduction electrons annihilation probability growth with a fluence increase can indicate an increase in the respective point defects concentration, then the Fermi momentum practical constancy indicates lack of changes in the electron structure of the latter. In other words, the vacancy defects configuration on the reached level of fluence remains the same. On the basis of positrons capture model one can calculate the average size of the defect region created in Ti as a result of electron irradiation: $r = 0.81 \text{ \AA}$. This means that the positrons capture centers in this case are really the vacancies.

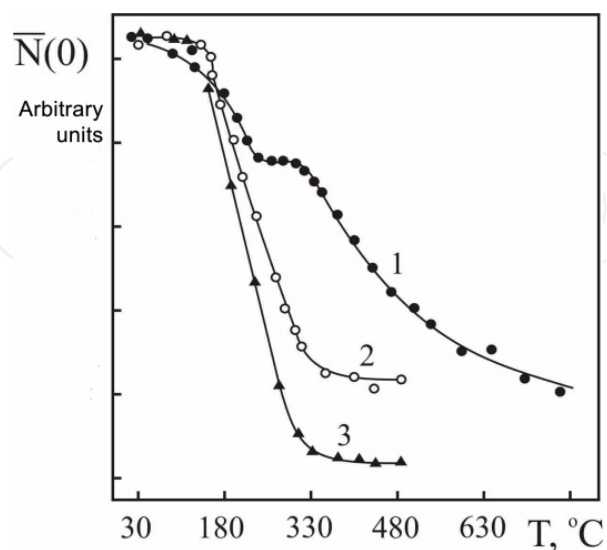

Figure 11. The structure damages annealing in deformed and electron irradiated titanium 1- deformed on $\epsilon = 50\%$; 2- electron irradiated $\Phi_1 = 10^{18} \text{ cm}^{-2}$; 3 - electron irradiated $\Phi_2 = 10^{19} \text{ cm}^{-2}$.

This statement is also confirmed by calculation results of the configuration parameter R_c , which is determined according to the positrons capture model (Table 2). It can be seen that within the calculation error R_c remains constant ($R_c = 1.55 \pm 0.05$), that is regardless of electrons fluence the radiation defects configuration remains invariant. Consequently, the observed increase of the probability of positrons annihilation with the conduction electrons F is caused only by a respective increase of radiation defects in Ti. These data are verified by the isochronal annealing results performed for three cases (Fig.11). One can see that in the temperature interval 170-240°C only one return stage for irradiated materials is observed, which is related to removal of radiation defects regardless of electrons fluence. The higher return effect value for $\Phi_2 = 10^{19} \text{ cm}^{-2}$ fluence in comparison with $\Phi_1 = 10^{18} \text{ cm}^{-2}$ fluence also confirms enhanced concentration of vacancy defects formation. The defect migration activation energy value did not exceed $E_a = 1.22 \pm 0.05 \text{ eV}$ and according to the data of [11, 12] it enabled us to identify them as point defects. Thus, the titanium structure modification by high energy electrons irradiation leads to formation of point defects of vacancy type, the concentration of which depends on the irradiation fluence.

3.4. Radiation induced modification of titanium structure at the helium ions irradiation

Use of accelerators of high energy charged particles plays quite an important role in studying radiation modification fundamental problems. This is first of all important for prediction of the construction materials behavior and change of their properties. To this end, the structure modification process of titanium binary alloys that contain 0; 1.2; 2.5; 3.3; and 4.1 at. % Ge; 1.2; 2.5; 4.3; 6.2 and 7.6 at.% Sn and 1.4; 2.9; 5.1 and 10.3 at.% In was performed. The modification was realized by α -particles irradiation with $E = 50 \text{ MeV}$ with the flux density $1.5 \cdot 10^{12} \text{ cm}^{-2} \text{ c}^{-1}$ and the temperature not higher than 70°C.

It should be noted that irradiation by α -particles with $E=50 \text{ MeV}$ causes significant deformation of the spectra shape that considerably exceeds the influence of the plastic deformation of sufficiently high degree $\varepsilon = 50\%$ (Fig.11). The probability of positron annihilation with conduction electrons as a result of irradiation by α -particles in all cases significantly exceeds its values for alloys both in initial state and also after strong plastic deformation with simultaneous and significant decrease of the Fermi angle θ_F . It is important that the nature of change of the concentration dependence of these parameters is preserved from one alloy to another. Meanwhile, those alloys, in which abnormally high increase of the annihilation parameter after plastic deformation is observed, also show this tendency after α -particles irradiation. For some alloys these changes exceed by more than twice the corresponding indicators for the deformed state. This indicates that the α -particles irradiation appears to be more effective on structure changes in metals than plastic deformation.

Stability of the each alloys system towards the α -particles exposure depends on the nature and concentration of the alloying element. The smallest stability towards the α -particles exposure was observed in the alloys containing 0.8 at.% Ge; 1.2 and 7.6 at.% Sn, as well as 1.4 and 7.4 at. % In. Therefore, the damageability of alloys of the indicated compositions in relation with ? Ti under α -particles irradiation is higher than for alloys of other compositions (Fig.12).

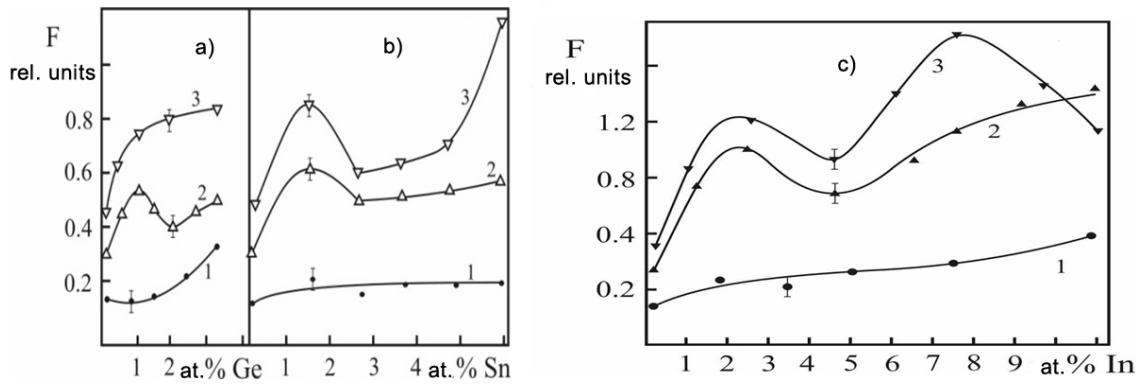

Figure 12. The alloys structure modification: Ti-Ge (a), Ti-Sn (b) and Ti-In (c) in different states: 1 – annealed; 2 – deformed by $\epsilon=50\%$; 3 – irradiated by α -particles with $E=50\text{MeV}$

On the basis of positrons capture model and assuming formation of new allocations in crystal structure due to α - particles irradiation we can estimate the average size of these regions. The sizes are: $r = 16 \text{ \AA}$ for Ti-1.4 Ge at.% alloy; $r = 15 \text{ \AA}$ for Ti-1.4 at.% In alloy and $r = 20 \text{ \AA}$ for Ti – 7.6 at.% Sn alloy. These data are confirmed by the isochronous annealing results.

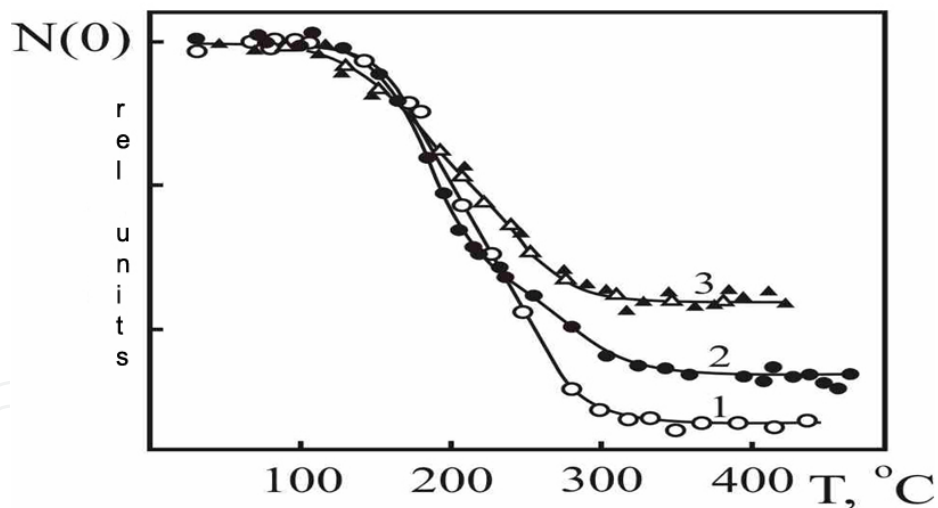

Figure 13. Annealing kinetics of titanium alloys, irradiated by α - particles with $E = 50\text{MeV}$: 1 - 1.2 at.% Ge 2 - 1.2 at.% Sn 3 - 2.9 at.% In

The results of isochronal annealing of the Ti irradiated alloys presented in Fig.13 reveal only one stage of return regardless of the composition of the alloy. This annealing is completed at the temperature of 300-320 $^{\circ}\text{C}$ with radiation defects migration activation energy of $E_a=1.50\text{-}1.55\text{eV}$ and corresponds to vacancy complexes that occur in the Ti alloys' α -phase.

3.5. The dose dependence of titanium alloys structure modification under α -particles irradiation

This characteristics is estimated by radiation defects accumulation kinetics at α -particles irradiation with 10^{14} ; $3.2 \cdot 10^{14}$; $3.2 \cdot 10^{15}$ and 10^{16} cm^{-2} fluences on the example of the Ti-Ge alloys system. The α -particles energy was $E=29$ MeV with the beam intensity $1.5 \cdot 10^{12}$ $\text{cm}^{-2}\text{s}^{-1}$ (Fig. 14). One can see that the accumulation curve character is practically not dependent on the Ge concentration. The 10^{14} – $5 \cdot 10^{15}$ cm^{-2} fluence is correspond to the incubation period of radiation defects accumulation. Further, the defects accumulation obeys the point defects clusterization principle.

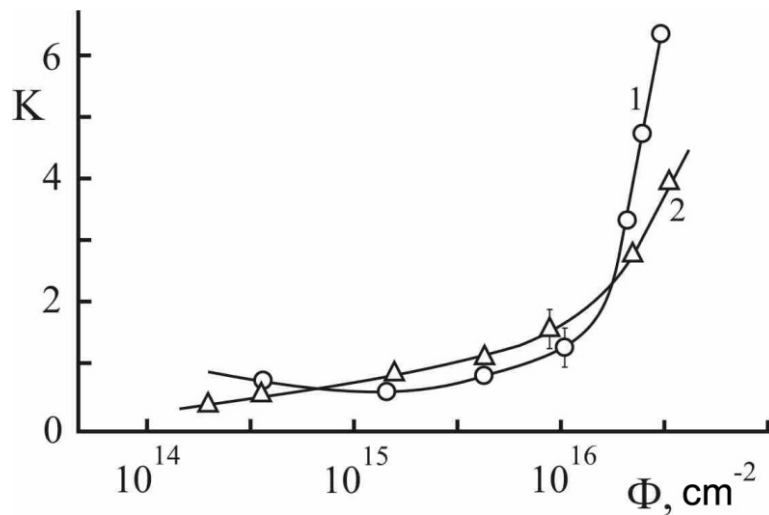

Figure 14. Positrons capture efficiency dosage dependencies for Ti (1) and Ti-3.1 at.% Ge (2)

3.6. The peculiarities of structure modification of titanium alloys irradiated by protons

By the time of setting the experiment for the purpose of studying radiation modifications of Ti and its binary alloys structure under irradiation by high energy protons, there was no a single research work with published results that was devoted to this problem. Therefore, investigation of radiation damageability caused by strong protons beam was realized on the example of Ti binary alloys, alloyed by Sn in aforementioned concentration. The Ti-Sn alloy samples in the initial annealed and deformed ($\varepsilon = 50\%$) states underwent irradiation by protons with $E = 30$ MeV up to two-value ($5 \cdot 10^{15}$ and $2.5 \cdot 10^{16}$ cm^{-2}) fluence for the purpose of elucidating not only the dopant agent role but also the material's history in the formation of the final defective structure of alloys. It is necessary to point that for the protons with $E = 30$ MeV, the thickness of the samples used (1 mm) was absolutely insufficient for providing their complete deceleration. The calculated value of protons energy on the backside of the samples differed from protons initial energy only by 5–6 MeV [15, 16]. Therefore, all investigated samples were irradiated actually by shooting. The results of this investigation are presented in Table 4. One can see that for the materials' initial state the alloying elements concentration increase has a

Alloys composition, at. %.	Materials state					
	Annealed	Plastic deformed $\epsilon=50\%$	Protons fluence, E=30MeV			
			$5 \cdot 10^{15} \text{ cm}^{-2}$		$2.5 \cdot 10^{16} \text{ cm}^{-2}$	
			After annealing	After deformation $\epsilon=50\%$	After annealing	After deformation $\epsilon=50\%$
Ti	0.22	0.38	0.30	0.41	0.42	0.45
Ti-1.2 Sn	0.25	0.44	0.36	0.32	0.38	0.36
Ti-2.5 Sn	0.22	0.39	0.29	0.34	0.31	0.38
Ti-4.3 Sn	0.26	0.41	0.28	0.37	0.38	0.40
Ti-6.2 Sn	0.27	0.41	0.34	0.33	0.37	0.46
Ti-7.6 Sn	0.26	0.43	0.30	0.36	0.41	0.41
Accuracy \pm	0.02	0.02	0.02	0.02	0.02	0.02

Table 4. The positrons annihilation probability in titanium alloys irradiated by protons

weak influence on positrons annihilation process nature both in respect of the probability $W_p = S_p/S_0$ and the Fermi angle θ_F .

At the same time the proton irradiation of annealed alloys leads to a significant increase of positrons annihilation probability at a fluence of $5 \cdot 10^{15} \text{ cm}^{-2}$: by 36% for Ti and by 50% - on an average for alloys containing 0.8 and 1.5 at.% of Ge. If we take the W_p value for the alloys deformed by $\epsilon = 50\%$ as saturating, then the results for alloys irradiated by protons from an annealed state confirms the absence of tendency of the annihilation parameter to saturate within the range of reached fluence level. The annihilation parameter increase with the fluence characterizes the respective increase of radiation defects concentration in the materials' structure. The largest increase of positron traps as a result of proton irradiation is observed in the alloys containing 1.2 and 7.6 at.% Sn, i.e. these alloys, as in the case of α -irradiation influence, manifest certain instability to proton irradiation influence.

Analysis of the results of alloys irradiation to up to $5 \cdot 10^{14} \text{ cm}^{-2}$ fluence in the previously deformed state testifies a completely opposite picture. In this case the positron annihilation probability takes substantially smaller values than before irradiation practically for all investigated alloys of this system. This tendency remains even after re-irradiation of up to $2.5 \cdot 10^{16} \text{ cm}^{-2}$ fluence, which indicates the significant role of the material's history and the dopant agent nature in the formation of the structure damages caused by proton irradiation. The primary decrease in the positron annihilation probability W_p caused by proton irradiation of deformed materials is probably related to the appropriate decrease in the efficiency of structure damages towards positron trapping. The following increase of W_p is obviously caused by probable radiation-stimulated reconstruction of alloys dislocation structure as a result of proton irradiation.

The calculation of the average size of these centers on the basis of a one-trap model positron capture for Ti-2.5 at% Sn alloy irradiated by $E = 30$ MeV protons up to $2.5 \cdot 10^{16} \text{ cm}^{-2}$ fluence gives $R_V = 10 \text{ \AA}$, i.e. in the investigated materials one can assume a generation of vacancy clusters.

These very peculiarities of the concerned problem are well confirmed by the results of isochronal annealing of structure defects. As an example, Ti and Ti-7.6 at% Sn alloy were chosen for studying annealing. These samples underwent all of the three abovementioned types of external exposure. The results of these investigations are reflected in Fig. 15(a) and (b) as curves of isochronal annealing. In each case, in order to establish the nature of the structural transformations, the curves of annealing for the deformed materials obtained earlier are provided. Comparing the annealing results for all states of the materials is useful as it enables formulation of quite important conclusions about some redistribution of defects in the crystal structure of materials that underwent a combined treatment. One can observe a pronounced low-temperature stage for Ti caused by an irradiation by protons up to $2.5 \cdot 10^{16} \text{ cm}^{-2}$ fluence from a deformed state within the temperature range of $60 - 220^\circ\text{C}$ (Fig. 15(a), curve 2). It occurred as a result of the transformation, evolution and redistribution of the initial defect structure generated by an intense plastic deformation under a heavy proton radiation. This stage significantly differs from that of annealing curve for deformed titanium (curve 1) both by form and by temperature region of manifestation.

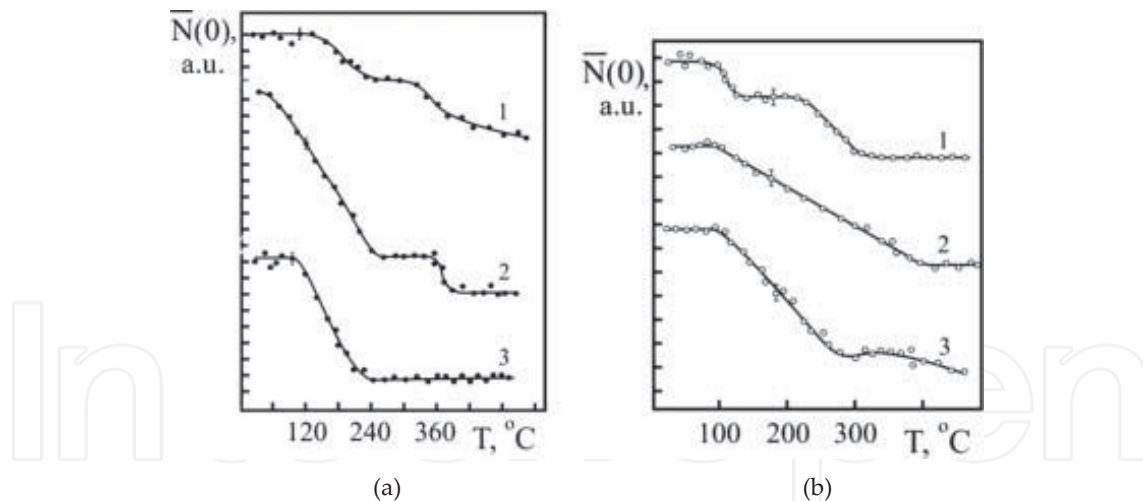

Figure 15. Kinetics of Ti (a) and Ti-7.6 at% Sn alloy (b) annealing under different types of exposure. 1 – deformed by $\epsilon = 50\%$; 2 – irradiated by protons in a deformed state; and 3 – the same in an annealed state.

In addition, one can observe a second high-temperature stage with $\Delta N_2 = 2.5\%$ in the temperature range of $330 - 360^\circ\text{C}$. The defect migration activation energies by stages were equal to $E_{a1} = 1.21 \text{ eV}$ and $E_{a2} = 1.93 \text{ eV}$, respectively. This fact confirms an assumption about dislocation structure evolution and its partial transformation into the vacancy structure.

3.7. The metals and their alloys structure modification under neutron irradiation

Relatively high stability of some Ti–Al system alloys to fast α -particle influence was shown above experimentally. Though, in the literature one can encounter contradictory assertions about radiation characteristics of these alloys [16]. For tackling this problem alloys of this system of compositions investigated earlier underwent irradiation by fission neutrons.

Irradiation of the annealed materials by fission neutrons with $E > 0.1$ MeV was conducted at the fluence up to $2 \cdot 10^{22} \text{ cm}^{-2}$ according to the method described above. The results of the realized investigations are presented in Fig.16.

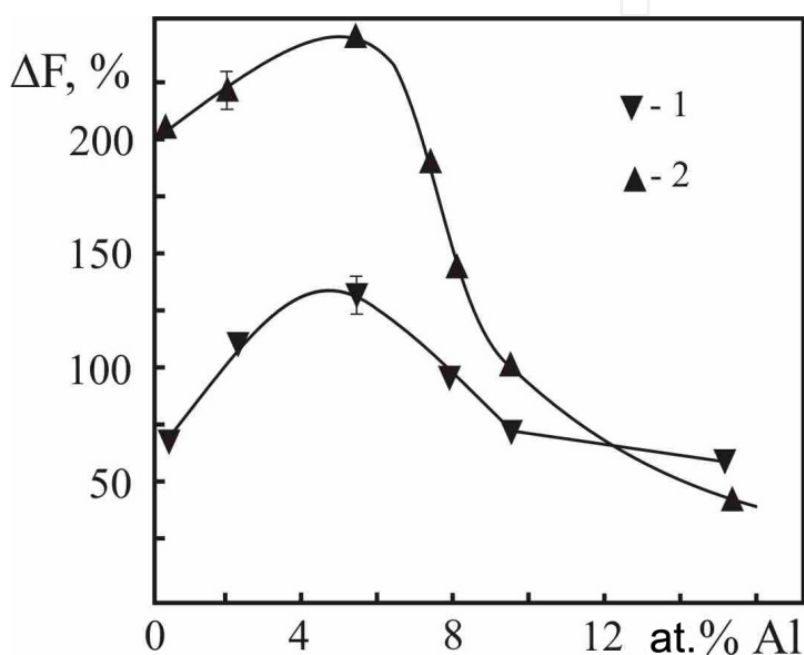

Figure 16. The concentration dependencies of annihilation relative probability for Ti-Al alloys, are subjected to plastic deformation (1) and neutron irradiation (2)

In the titanium alloys that are inclined to phase transformations, as a result of plastic deformation one should expect formation of defects related to the $\alpha \rightarrow \beta$ transformation. The vacancy-dislocation structure, which appears after strong neutron flux, can stimulate formation of certain allocations in the crystal, an integral part of which is the lattice instability related to the energy excess introduced by irradiation. One can see from the data that for Ti and 5.2 at.% of Al alloy the annihilation parameter ΔF increases under the neutron irradiation by more than three times, while after plastic deformation by $\varepsilon = 50\%$ it was only 64 and 127 %, respectively. Such behavior of the annihilation parameter indicates that with an increase of Al content in the alloy considerable changes in the defects electron density distribution occur.

At the same time sufficiently close values of the annihilation parameter for heavily doped alloys with 10.2 and 16.5 at.% of Al as a result of deformation and neutron irradiation can validate the possibility of structure damages formation in these alloys that assures an equivalent efficiency of positrons capture potentials. Materials, which manifest this regularity,

possess enhanced stability to external influence, including a neutron irradiation. The Ti alloys containing more than 10 at.% of Al probably belong to this category of materials.

For investigation of the radiation defects accumulation kinetics, alloys of Ti-Al system were irradiated by fission neutrons in the wide range of fluencies: 10^{15} ; 10^{16} ; 10^{17} ; 10^{18} ; 10^{19} and $2 \cdot 10^{19}$ cm^{-2} . Fig 17a depicts the dose dependence of ΔF parameter for Ti and its three alloys with Al. The sharply distinct nature of change of this parameter related to the alloys composition should be noted. Given these conditions one can assume that in the alloys, which are different by composition, the changes of the defects concentrations and their configuration can also be different. The strongly concentrated alloys are more stable to neutron exposure and for this reason the fluence increase of the latter is not accompanied by sharp changes of the annihilation parameters and this is probably stimulated by an interatomic bond energy increase in these alloys comparing with Ti and Ti-5.2 at.% Al alloy.

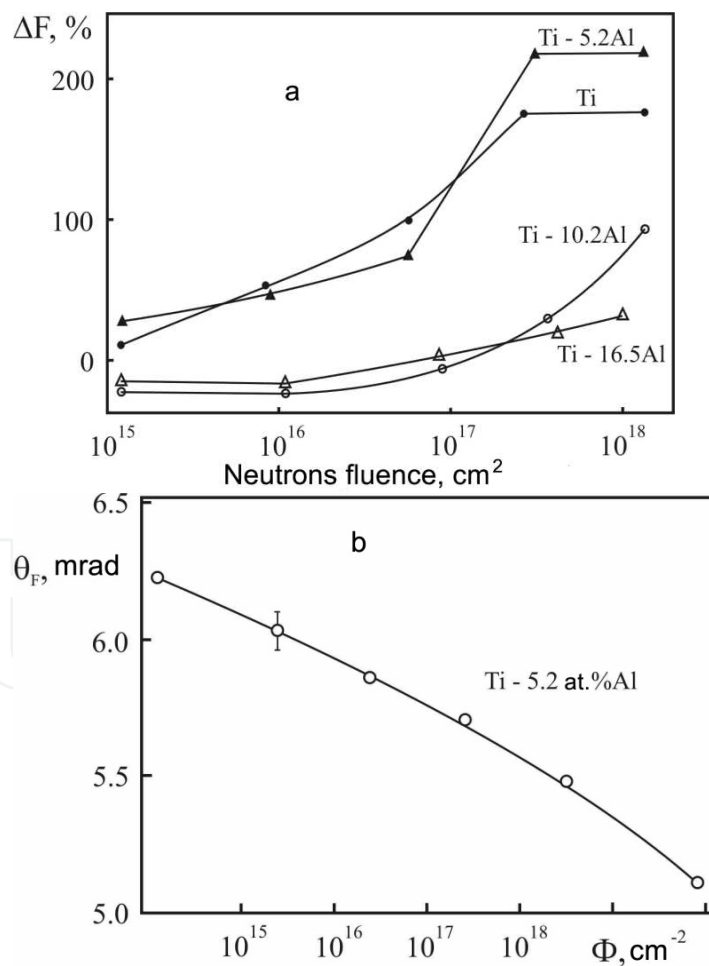

Figure 17. The dosage dependence of annihilation parameters change kinetics in Ti-Al alloys irradiated by fission neutrons (a) and Fermi momentum (b).

The certain clarity about the processes can be obtained from the annealing data. Firstly, let us consider the radiation defects annealing spectra in Ti-5.2 at.% of Al alloy, irradiated by neutrons at different fluencies (Fig.18a). As a result of neutron irradiation to up to 10^{17} cm⁻² fluence, the generated radiation defects in the crystal structure are annealed in one stage in temperature range of 110 - 210°C (curve 1) with migration energy activation $E_{a1} = 1.27$ eV. This stage evidently corresponds to the return of small vacancy clusters.

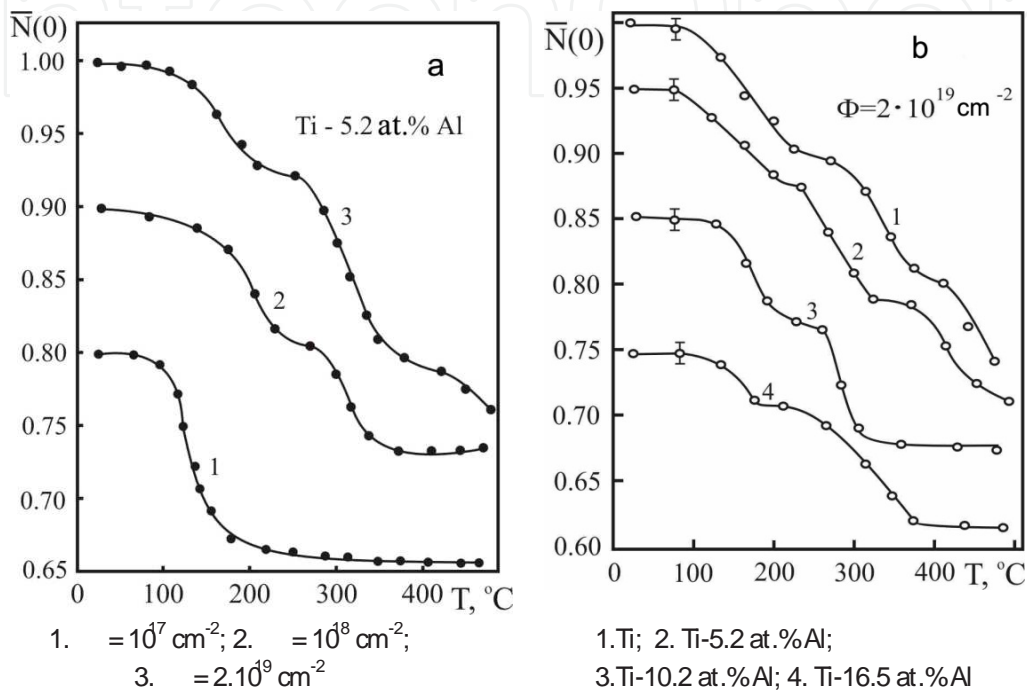

Figure 18. Dosage (a) and concentration (b) dependencies of annealing kinetics for Ti-Al alloys irradiated by neutrons

The fluence increase by single-order (to up to 10^{18} cm⁻²) leads to the radiation defects occurrence in the structure and these defects are annealed in two stages (curve 2) and with the fluence of $2 \cdot 10^{19}$ cm⁻² the full healing of the structure damages is performed in three evidently expressed annealing stages (curve 3).

A considerable interest is presented by the annealed defects spectra against the alloys composition irradiated at the same neutron dose $2 \cdot 10^{19}$ cm⁻². It is easy to determine that in the different alloys the radiation defects accumulation process occurs differently (Fig.18b).

In conclusion, a comparative analysis of titanium radiation damageability under the four types of particle radiation influence can be performed: electrons, protons, α -particles and fission neutrons. This comparison can only be approximate, since it is practically impossible to ensure same conditions for all cases. The titanium and its alloys radiation damageability is substantially higher at α -particles irradiation. Taking into account radiation defects generation rate the most damaging are (detrimental) α -particles, which are then followed by fission neutrons, protons, and electrons.

4. Titanium alloys defect structure modification by hydrogen saturation method

It is generally acknowledged that alterations in the metal electron structure caused by hydrogen should be taken into account when interpreting physical properties of the metal-hydrogen system. This is especially important for the Ti-H system, because of the high absorption capacity of titanium with respect to hydrogen, which to a significant degree have an influence on its technological properties. According to the well-known proton model, the proton gas penetrates into the electron shells and changes their energy state. At the same time the intensity of the force fields grows with an increase of the temperature of the system, which is accompanied by intensification of interaction between proton gas and electron shells.

In order to tackle this task, as an objects of the experimental study iodide titanium and a system of Ti-Al alloys (up to 50 at.% Al) were taken [13,17]. For hydrogenation, the original materials were annealed at 900⁰ C, deformed by rolling by $\varepsilon = 50\%$, and irradiated by 50MeV α -particles up to a fluence of $5 \cdot 10^{15} \text{ cm}^{-2}$. Hydrogenation was implemented by Siverts saturation method at the temperature of 200⁰ C during 3 hours and under 500⁰ C during 1 hour. The hydrogen pressure was $(4.9-5.9) \cdot 10^5 \text{ Pa}$. Hydrogen was produced by desorption of the hydrides LaNi_5H_x and TiH_x . Before hydrogenation, the samples were kept under the room temperature in vacuum of 0.13–1.33 Pa for 10 hours directly in the reactor, when hydrogen was admitted after the previous processing. The pressure was measured by a standard manometer with accuracy of 300 Pa with the volume of the reactor system being equal to $4 \times 10^{-4} \text{ m}^3$. After samples hydrogen saturation at $T=200^\circ\text{C}$ in any different initial state the change of their weight could not be locked. At $T=500^\circ\text{C}$ the hydrogen saturation flows more intensively due to hydrogen diffusion acceleration, and samples' weight substantially increases. For interpretation of the investigation results the annihilation parameters shown in Table 5 were used.

Material state	Titanium			Ti-5.2 at. % Al			Ti-1.4 at. % V		
	F	θ_f mrad	ΔF %	F	θ_f mrad	ΔF %	F	θ_f mrad	ΔF %
Annealed (before hydrogenation)	0.26	5.82	-	0.34	5.61	-	0.27	6.12	-
Annealed+H (200°C)	0.29	5.85	15	0.33	5.83	0	0.29	5.92	9
Annealed+H (500°C)	0.37	5.92	41	0.46	5.92	36	0.33	5.91	23
$\varepsilon 50\%+H$ (200°C)	0.32	6.05	22	0.46	5.82	35	0.38	6.22	43
$\alpha+H$ (200°C)	0.47	5.18	81	0.48	5.33	42	0.46	5.03	72
$\alpha+H$ (500°C)	0.34	6.03	28	0.45	5.61	32	0.39	5.63	45
Ti pressed powder	0.40	5.25	54	Error \pm			0.01	0.05	1.0
TiH _x Pressed powder	0.50	5.00	90						

Table 5. Annihilation parameters of hydrogenated titanium alloys

In ideal defect-free single crystals hydrogen dissolves in the metal, occupying the lattice interstitial positions and causing displacement of the metal atoms from their equilibrium positions. In the real crystals, though hydrogen segregates in various lattice defects, which leads to reduction of probability of positrons capture. But hydrogen saturation of materials in annealed state at $T = 200^{\circ}\text{C}$ does not practically affect annihilation parameters. If we increase the temperature of the hydrogen saturation process to up to $T=500^{\circ}\text{C}$, then hydrogen absorption accelerates, which consequently causes more active hydrogenation of that material. This is effectively reflected in the respective increase of F probability, but angle of Fermi momentum θ_F remains constant in the range of calculation error. This means that the hydrogen saturation process is not accompanied by new defects formation in the metal's structure and electron subsystem in positrons locating places does not experience significant reconstruction.

Plastically deformed metals facilitate accumulation of a considerable amount of hydrogen. The hydrogen saturation at comparatively low temperature (200°C) is obviously accompanied by atomic hydrogen capture by structural damages. The new complexes appear in crystalline lattice which decrease the capture efficiency of positrons localization centers, previously introduced by the plastic deformation. The hydrogen saturation temperature increase up to 500°C converts materials into a hydride state, which caused the cast, compact metals to crumble into powder. The reason for destruction of the compact metal after hydrogen saturation under 500°C can be formation of cracks of deformative nature related to the hydrides formation. The penetrated hydrogen is dissociated in the internal surface of these defects but with formation of less mobile molecules which with more intensive arrival from outside gradually become bigger by volume and eventually cause sample's destruction.

In order to establish the nature of the observed phenomena, the hydrogen accumulation nature in Ti and its alloys with Al in annealed state was investigated. In clean Ti, there are practically no reasons that could prevent hydrogen from accumulation to significant concentrations (Fig. 19a). At the same time, intensity of hydrogen absorption by annealed alloys of Ti-Al system sharply drops with an increase of Al concentration in the alloys (Fig.19b). Therefore, the capabilities of Al, as an absorber of hydrogen, are rather limited comparing to those of Ti. This is reflected in the annihilation parameter changes.

Thus, the observed changes in the electron structure of the defect material indicate, on the one hand, on hydrogen's significant role in its formation and, on the other hand, on enhancement of the interaction of hydrogen with the material due to the presence of damages of deformative and radiative character.

Isochronal annealing behavior of these materials is presented in Fig.19. For irradiated by electrons and not saturated by hydrogen Ti one stage of restoration is allocated under annealing in the temperature range $170\text{-}240^{\circ}\text{C}$ with $E_a = 1.22$ eV. As a result of irradiation of the hydrogen saturated metal, the displacement of the starting point of the first stage recovery up to $225\text{-}230^{\circ}\text{C}$ is observed, which finishes near 330°C . Therefore, the bound state vacancy-hydrogen in Ti has a higher temperature range of dissociation and annealing with $E_a = 1.38$ eV, than simple vacancy defects.

Fig. 19 Hydrogen accumulation kinetics (a), Al influence on hydrogen accumulation rate in Ti (b) and defects annealing kinetics in titanium (c)

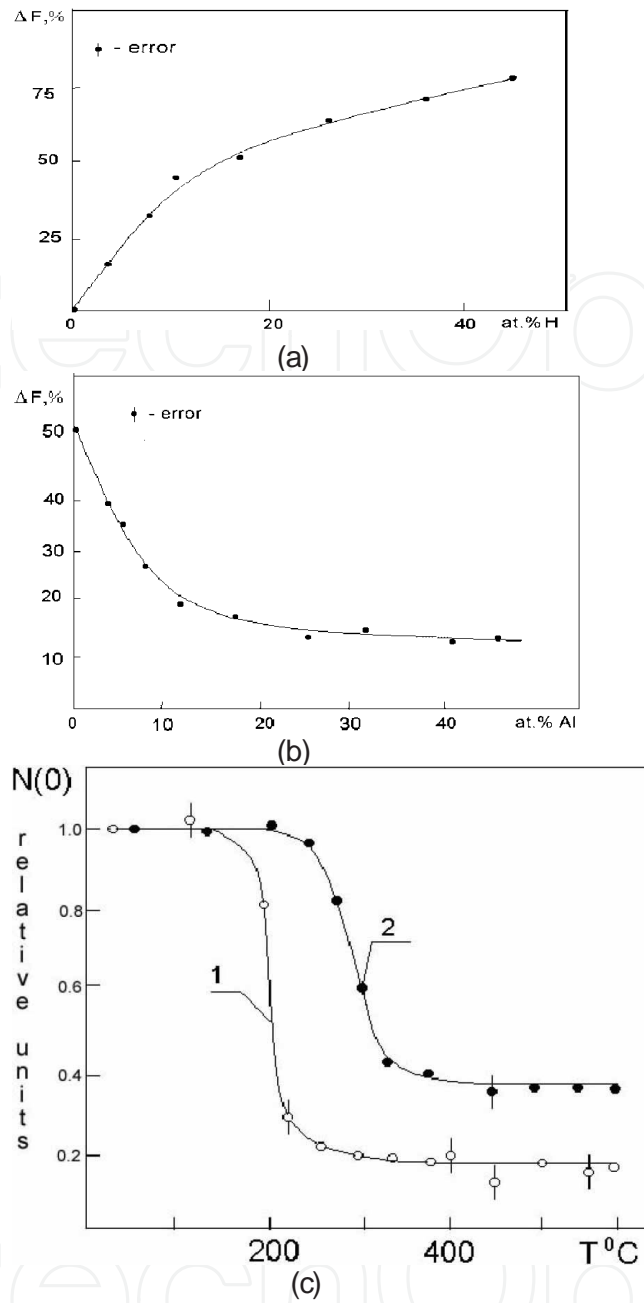

Figure 19. a. Kinetics of hydrogen accumulation ΔF in titanium. b. Effect of aluminum addition on hydrogen accumulation ΔF in titanium. c. Annealing kinetics of radiation defects in titanium

5. Conclusion

Complex and systematic investigations of the electron structure of the titanium binary alloys depending on the type and concentration of the alloying elements and the modification degree by plastic deformation method enabled formulation of the following conclusions:

- for the initial state the alloys electron structure reveals a weak dependence on type and concentration of an alloying element, whereas the structure modification by plastic deformation causes nonmonotonic changes to the annihilation parameters. At the same time, the main changes in the character of the annihilation parameters are observed at deformations of up to $\epsilon \leq 30\%$, above which saturation is observed;
- it was shown by X-ray investigations that in the metals modified by deformation one can find a certain amount of new phase precipitates which are interpreted as the β - phase of base metal in the matrix of α -phase, with vacancy-dislocation structure and electron density substantially smaller than in the initial phase;
- it was shown that after electron irradiations, mono vacancies emerge in the titanium crystalline lattice and they remain at the room temperature; these mono vacancies ensure capture of positrons, electron structure and configuration of which do not depend on electrons fluence and significantly differ from the corresponding characteristics of vacancy formations generated by plastic deformation;
- it was established that the electron structure and stability of each alloys system to the influence of high energy α -particles are the function of alloying elements nature and their concentration;
- the possibility of the irradiation-induced swelling suppression in the titanium alloys by selective alloying and preliminary structure defects introduction was experimentally demonstrated;
- the role of the initial structure defects in titanium alloys under the high energy proton irradiation is manifested in their transformation, evolution and redistribution with sharply distinct electron structure;
- it was shown that in the deformed state hydrogen accumulation in titanium occurs in the defect regions with hydride formation which afterwards leads to sample destruction;
- for hydrogen corrosion reduction it is necessary to use titanium alloyed by Al (over 5.2 at. %);
- the radiation effects in preliminary hydrogen saturated titanium manifested themselves in emergence of hydrogen atom-vacancy coupled state.

Author details

Kanat M. Mukashev¹ and Farid F. Umarov²

1 Department of the Theoretical and Experimental Physics of the National Pedagogical University after Abai, Almaty, Kazakhstan

2 Department of Geology and Earth Physics of the Kazakh-British Technical University, Almaty, Kazakhstan

References

- [1] Li-witing, G. Thermalization of Positrons in Metals. In book: Positrons annihilation in solids. (1960). pp., 17-20.
- [2] Holland, A. Current investigations of point defects in metals. In book: Point Defects in Solids. Mir.(1979). pp., 243-370.
- [3] Stewart, A. T. Positron annihilation in metals. *Canad. Jour. Phys.* (1957). , 35, 168-201.
- [4] Mantl, S, & Triftshauser, W. Defect annealing studies of metals by positron annihilation and electrical resistivity measurements. *Phys. Rev.* (1978). N4,-, 17, 1645-1652.
- [5] Regnier, P, & Dupony, I. M. Prismatic slip in Be and the relative ease of glide in H.P.C. metals. *Phys.Stat.Sol. (a)*. (1970). N1.-, 39, 79-93.
- [6] Miller, G. L. Zirconium. *In.Lit.* (1955). P.320.
- [7] Klebro, L. M, Hargriva, M. E, & Loretto, M. X. The internal energy change at metals return and recrystallization. M.: Metallurgy. (1966). pp., 69-122.
- [8] Larikov, L. N. Plastic deformation and atoms mobility in crystalline lattice. In book: Metals, Electrons, Lattice. Kiev, Naukova Dumka. (1975). pp., 315-354.
- [9] Orlov, A. N. Trushin Yu.V. The energy of point defects in metals. *Energoatomizdat.* (1983). P.57.
- [10] Ballufi, R. M, Keller, J. S, & Simmons, R. O. The modern state of knowledge about point defects in metals with FCC-Lattice./ In book: The metals return and recrystallization. Metallurgy. (1966). pp., 9-68.
- [11] Mikhalenkov, V. S. To question about plastic deformation influence on positrons annihilation in metals. *Ukr. Phys. Journ.* (1972). B.17. N5. pp., 840-841.
- [12] Mikhalenkov, V. S. Recovery of the angular distribution of annihilation photons by annealing of deformed copper allos. *Phys. Stat. Solid. (a)* (1974). N2.-, 24, k111-k113.
- [13] Mukashev, K. M. A slow positrons physics and positron spectroscopy.- Almaty. (2010). P.508.
- [14] Shishmakov, A. S, & Mirzaev, D. A. Khmelinin Yu. F. The X-ray diffraction on packing defects in metals with HCP-lattice. *Met. Physics and Metallurgy.* (1974). B.37. N2. pp., 313-321.
- [15] Mukashev, K. M, & Umarov, F. F. Positron annihilation in titanium alloys modified by proton irradiation. *Radiation Effects & Defects in Solids.* pp.1-11,167(1)(2012).
- [16] Dextyar, I. Ya., Mukashev K.M., Chursin G.P. The high energy α -particles irradiation influence on electron-positron annihilation in titanium alloys. *Voprosy atomnoy nau-*

ki i tehniki. Ser. Fizika radiat. Povrejeniy I radiat materialovedenie. (1982). N4 (23)-12-16pp.

- [17] Mukashev, K. M, & Umarov, F. F. Hydrogen behavior in electron-irradiated titanium alloys studied by positron annihilation method. *Radiation Effects & Defects in Solids* pp.415-423, 162(6) (2007).

IntechOpen

IntechOpen

