

We are IntechOpen, the world's leading publisher of Open Access books Built by scientists, for scientists

4,800

Open access books available

122,000

International authors and editors

135M

Downloads

Our authors are among the

154

Countries delivered to

TOP 1%

most cited scientists

12.2%

Contributors from top 500 universities



WEB OF SCIENCE™

Selection of our books indexed in the Book Citation Index
in Web of Science™ Core Collection (BKCI)

Interested in publishing with us?
Contact book.department@intechopen.com

Numbers displayed above are based on latest data collected.
For more information visit www.intechopen.com



Wind Farms as Negative Loads and as Conventional Synchronous Generation – Modelling and Control

Roberto Daniel Fernández,
Pedro Eugenio Battaiotto and Ricardo Julián Mantz

Additional information is available at the end of the chapter

<http://dx.doi.org/10.5772/54089>

1. Introduction

The concept of negative load [1,2] has been applied to wind generators to indicate their capability for delivering current meanwhile their voltage is imposed by the electrical system at the connection point. More recently, the same concept was applied for studying dispatch or spinning reserve considering that the total regulating power required at any moment depends on the sum the system load and the wind power which can counterbalance or increase load variations. In this way, aggregated variations must be investigated regarding wind power as negative load [3,4].

Traditionally, induction generators, squirrel cage and double fed (wound rotor) induction generators (DFIG) have been considered as current sources (or power ones) in power system analysis. Indeed, for analyzing power system stability in a linear frame, i.e. by small signal analysis, it is possible to find the power system eigenvalues and concluding about stability following the next steps:

1. Writing differential algebraic non linear model of the power system considering wind turbines wind induction machines as negative loads.
2. Linearizing the non linear model [2,5,6].

Checking the movement of the system eigenvalues when wind fixed speed generation is increased [7] or when different control strategies for active and reactive powers are applied to DFIGs wind farm [8,9].

Even when modelling wind generators or wind farms as current sources have shown through linear and non linear analysis [10] that wind farms can contribute to the power sys-

tems stability, it is important to consider that power systems have been developed from voltage synchronous generation, i.e. they (power systems) have not been developed with variable current sources as wind farms. For this reason, it is usually assumed that, as cited in [11], *'These plants (wind farm ones) exhibit static and dynamic characteristics that differ fundamentally from that of conventional generators. As a result, wind power plants do not fit the template for models of conventional generating facilities.'*

However, considering wind farms as (variable) voltage sources could help not just for a better understanding of induction machines in an electrical grid but also for mimicking conventional voltage source behaviors with wind power plants.

In this way, this chapter develops the equivalent model of induction generators representing them as a voltage sources with a series impedance. As a consequence, aside from the variability of wind, it would allow to analyze wind energy generation as another voltage source in power systems and, then, it should be possible to introduce "standard" rules for conventional generation to non conventional ones.

The structure of this chapter is as follows. Firstly, the concept of "general reference frame" is introduced in order to analyze squirrel cage and double fed induction machines. The dynamics model of the induction machine is deduced by considering a common simplification about (fast) stator dynamics. Then, equivalent Thevenin models are presented according to internal voltages sources and as a which are functions of the active and reactive powers. Secondly, it is shown that it is possible controlling active and reactive wind generator powers. Finally, a Thevenin aggregated model of the wind farm is proposed and some stability concerns of power systems are considered. In this way, Lyapunov theory is applied looking for demonstrating wind farms contribution to the power system stability considering wind farms as currents sources but also as voltage ones. In this last regard some wind farm control rules are derived from exploiting similarities between conventional generation and wind farms.

2. Induction machine equations in different reference frames

This section relies in [12] for presenting induction machine dynamics from a two axes general reference frame.

It is well known that electrical machines solve the problem of obtaining a rotating field by employing three windings sinusoidally distributed and separated by 120° (mechanical degrees) which are feeded by three sinusoidal stator 120° electrical degree phase shift. However, because of field distributions are the same along the third dimension (the machine shaft direction), these field distributions are analyzed in the plane where only are needed two linearly independent directions for characterizing any movement. The relationship between the three-phase (A, B and C for stator and a, b and c for rotor) and two phase voltages taking into account natural frames (fixed to the stator $sD - sQ$ and fixed to the rotor $r\alpha - r\beta$ for stator and rotor quantities, respectively) are:

$$\begin{bmatrix} u_{s0} \\ u_{sD} \\ u_{sQ} \end{bmatrix} = \frac{2}{3} \begin{bmatrix} 1/2 & 1/2 & 1/2 \\ 1 & -1/2 & -1/2 \\ 0 & \sqrt{3}/2 & -\sqrt{3}/2 \end{bmatrix} \begin{bmatrix} u_{sA} \\ u_{sB} \\ u_{sC} \end{bmatrix} \quad (1)$$

$$\begin{bmatrix} u_{r0} \\ u_{r\alpha} \\ u_{r\beta} \end{bmatrix} = \frac{2}{3} \begin{bmatrix} 1/2 & 1/2 & 1/2 \\ 1 & -1/2 & -1/2 \\ 0 & \sqrt{3}/2 & -\sqrt{3}/2 \end{bmatrix} \begin{bmatrix} u_{rA} \\ u_{rB} \\ u_{rC} \end{bmatrix} \quad (2)$$

By considering the two axes description, quantitative and qualitative analyses of induction machines can be simplified and also vector control concepts can be used. In this way, the contribution of vector control is based in controlling the induction machines active and reactive powers independently and/or controlling them as DC equivalent ones.

In a general reference frame, all induction machine variables are referred to a real axis known as direct axis x and to the quadrature axis y both rotating at the reference frame speed $\omega_g = d\theta_g/dt$ as shown in Figure 1. In this figure, θ_g is the angle of the real axis x measure from sD .

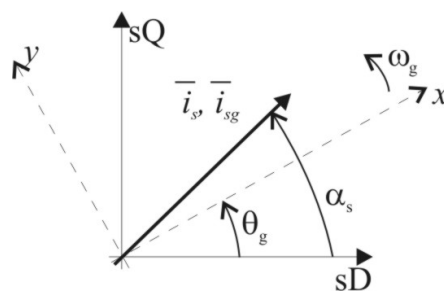

Figure 1. Stator current vector in a general reference frame

Then, the current stator phasor defined in the general framework, is:

$$\bar{i}_{sg} = \bar{i}_s e^{-j\theta_g} = i_{sx} + j i_{sy}$$

where upper bar indicates phasor quantities.

Also,

$$\bar{u}_{sg} = \bar{u}_s e^{-j\theta_g} = u_{sx} + j u_{sy}$$

$$\bar{\psi}_{sg} = \bar{\psi}_s e^{-j\theta_g} = \psi_{sx} + j \psi_{sy}$$

With \bar{u}_s and $\bar{\psi}_s$ stator voltage and (linked) flux space phasors in the general reference frame.

At the rotor side, Figure 2 shows three frames, rotor ($r\alpha$ and $r\beta$), stator (sD and sQ) and general (x and y) and their angles θ_r , 0 and θ_g , respectively.

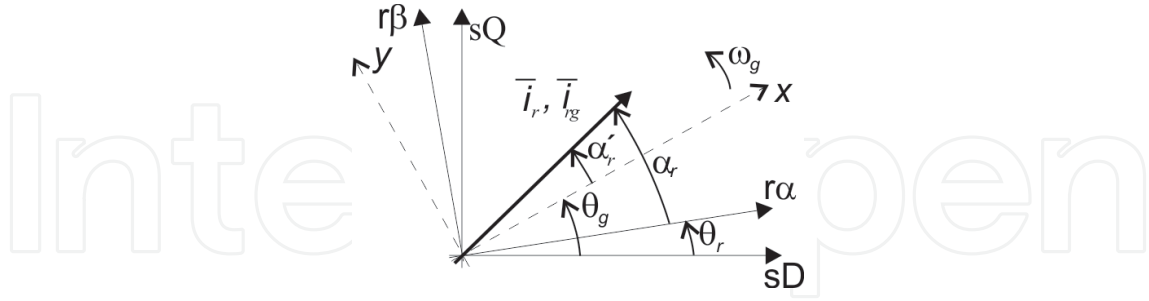

Figure 2. Different reference frames for the current rotor phasor

Meanwhile, the current phasor in the rotor reference frame can be expressed as $\dot{i}_r = |\dot{i}_r| e^{j\alpha_r}$, in the general reference frame is $\dot{i}_{rg} = |\dot{i}_r| e^{j\alpha_r'}$ with $\alpha_r' = \alpha_r - (\theta_g - \theta_r)$. Then,

$$\dot{i}_{rg} = |\dot{i}_r| e^{j\alpha_r} e^{-j(\theta_g - \theta_r)} = \dot{i}_r e^{-j(\theta_g - \theta_r)} = i_{rx} + j i_{ry}.$$

Also, rotor voltage and (linked) flux space phasors in the same frame are:

$$\bar{u}_{rg} = \bar{u}_r e^{-j(\theta_g - \theta_r)} = u_{rx} + j u_{ry}$$

$$\bar{\psi}_{rg} = \bar{\psi}_r e^{-j(\theta_g - \theta_r)} = \psi_{rx} + j \psi_{ry}.$$

Finally, induction machine phasor expressions are:

$$\bar{u}_{rg} = R_r \dot{i}_{rg} + \frac{d\bar{\psi}_{rg}}{dt} + j(\omega_g - \omega_r) \bar{\psi}_{rg},$$

$$\bar{u}_{sg} = R_s \dot{i}_{sg} + \frac{d\bar{\psi}_{sg}}{dt} + j\omega_g \bar{\psi}_{sg}$$

being R_s and R_r stator and rotor resistances, respectively, and $\bar{u}_{rg} = 0$ when a squirrel cage machine is considered. Additionally, stator and rotor fluxes can be expressed in terms of current phasors, and the stator, rotor and magnetizing inductances (L_s, L_r, L_m respectively)

$$\bar{\psi}_{sg} = L_s \dot{i}_{sg} + L_m \dot{i}_{rg}$$

$$\bar{\psi}_{rg} = L_r \dot{i}_{rg} + L_m \dot{i}_{sg}.$$

Last four equations can be rewritten compactly in matrix form as follows:

$$\begin{bmatrix} \bar{u}_{sg} \\ \bar{u}_{rg} \end{bmatrix} = \begin{bmatrix} R_s & 0 \\ 0 & R_r \end{bmatrix} \begin{bmatrix} \dot{i}_{sg} \\ \dot{i}_{rg} \end{bmatrix} + \frac{d}{dt} \begin{bmatrix} L_s & L_m \\ L_m & L_r \end{bmatrix} \begin{bmatrix} \dot{i}_{sg} \\ \dot{i}_{rg} \end{bmatrix} + j\omega_g \begin{bmatrix} L_s & L_m \\ L_m & L_r \end{bmatrix} \begin{bmatrix} \dot{i}_{sg} \\ \dot{i}_{rg} \end{bmatrix} - j\omega_r \begin{bmatrix} 0 & 0 \\ L_m & L_r \end{bmatrix} \begin{bmatrix} \dot{i}_{sg} \\ \dot{i}_{rg} \end{bmatrix}, \quad (3)$$

or by considering real and imaginary components:

$$\begin{bmatrix} u_{sx} \\ u_{sy} \\ u_{rx} \\ u_{ry} \end{bmatrix} = \begin{bmatrix} R_s + pL_s & -\omega_g L_s & pL_m & -\omega_g L_m \\ \omega_g L_s & R_s + pL_s & \omega_g L_m & pL_m \\ pL_m & -(\omega_g - \omega_r)L_m & R_r + pL_r & (-\omega_g - \omega_r)L_r \\ (\omega_g - \omega_r)L_m & pL_m & (\omega_g - \omega_r)L_r & R_r + pL_r \end{bmatrix} \begin{bmatrix} i_{sx} \\ i_{sy} \\ i_{rx} \\ i_{ry} \end{bmatrix} \quad (4)$$

Where u_{sx} , u_{sy} and i_{sx} , i_{sy} are stator voltages and currents in the general reference frame. Identical considerations remain for rotor quantities. If $\omega_g = 0$, it is obtained the 'commutator model', but if it is employed $\omega_g = \omega_{syn}$ the expression [4] can be rewritten as:

$$\begin{bmatrix} u_{sx} \\ u_{sy} \\ u_{rx} \\ u_{ry} \end{bmatrix} = \begin{bmatrix} R_s + pL_s & -\omega_1 L_s & pL_m & -\omega_1 L_m \\ \omega_1 L_s & R_s + pL_s & \omega_1 L_m & pL_m \\ pL_m & -s\omega_1 L_m & R_r + pL_r & -s\omega_1 L_r \\ s\omega_1 L_m & pL_m & s\omega_1 L_r & R_r + pL_r \end{bmatrix} \begin{bmatrix} i_{sx} \\ i_{sy} \\ i_{rx} \\ i_{ry} \end{bmatrix} \quad (5)$$

with ω_{syn} the synchronous speed and $\omega_{syn} - \omega_r = s\omega_{syn}$ with s the slip.

3. Thevenin equivalent of asynchronous machines

3.1. General reference frame - Cartesian coordinates

As presented in Appendix A and beginning with [5,13,14]:

$$\bar{u}_{sg} = R_s \bar{i}_{sg} + j\omega_g \bar{\psi}_{sg} \quad (6)$$

$$\bar{u}_{rg} = R_r \bar{i}_{rg} + \frac{d\bar{\psi}_{rg}}{dt} + j(\omega_g - \omega_r) \bar{\psi}_{rg} \quad (7)$$

the Thevenin equivalent of an asynchronous machine in cartesian coordinates is:

$$\bar{u}'_{sg} = -R_s j \bar{i}_{sg} + \omega_g \left(L_s - \frac{L_m^2}{L_r} \right) \bar{i}_{sg} + \bar{u}_{sg} \quad (8)$$

$$\frac{d\bar{u}'_{sg}}{dt} = \omega_g \frac{L_m}{L_r} j\bar{u}_{rg} + R_r \frac{L_m^2}{L_r^2} \omega_g j\bar{i}_{sg} - (\omega_g - \omega_r) j\bar{u}'_{sg} - \frac{R_r}{L_r} \bar{u}'_{sg} \quad (9)$$

Meanwhile expression (9) shows the internal voltage dynamics, expression (8) indicates how the stator current changes when \bar{u}'_{sg} varies (assuming that \bar{u}_{sg} is constant because of the induction machine is connected to an electrical grid where the voltage connection remains constant).

For clarity's sake, a typical qualitative analysis involves next steps which are carried out over a fixed speed (squirrel cage) wind generator:

1. At steady state $\frac{d\bar{\psi}_{rg}}{dt} = 0$.
2. At time $t = t_1$ there is a rotor speed change (wind velocity changed).
3. From (7) with $u_{rg} = 0$ a rotor flux variation appears $\left(\frac{d\bar{\psi}_{rg}}{dt} \neq 0\right)$.
4. Rotor flux change produces an internal stator voltage change provided that $\bar{u}'_{sg} = j\omega_g \frac{L_m}{L_r} \bar{\psi}_{rg}$.
5. \bar{u}'_{sg} dynamics evolves according to (9).

Active and reactive power are changed by modifying the internal voltage source. Indeed, provided that $\bar{u}_{sg} = \text{constant}$, \bar{i}_{sg} must change and then the associated powers. As a consequence, in squirrel cage wind generators active and reactive powers change according to the wind velocity. i.e. they are uncontrollable from the wind generator point of view. On the other side, it is known that by modifying pitch blades the active power from squirrel cage wind generators can be regulated. In this case the reactive power is a consequence of the active power control.

3.2. Dynamic model in polar coordinates

The Thevenin equivalent, i.e. the internal voltage magnitude and its phase, allows analyzing and considering induction machines (fixed and variable speed wind generators) in an electrical perspective looking for integrating wind generators when studying stability issues of power systems.

Beginning with the Cartesian Coordinates:

$$\frac{d\bar{u}'_{sg}}{dt} = \frac{d}{dt} \sqrt{u'^2_{sx} + u'^2_{sy}}$$

$$\frac{d\bar{u}'_{sg}}{dt} = \frac{1}{\sqrt{u'^2_{sx} + u'^2_{sy}}} \left(2u'_{sx} \frac{du'_{sx}}{dt} + 2u'_{sy} \frac{du'_{sy}}{dt} \right),$$

From expressions (8) and (9) it is possible to obtain the internal voltage derivative and its phase:

$$\frac{d\bar{u}'_{sg}}{dt} = \frac{1}{\bar{u}'_{sg}} \left[u'_{sx} \left(-\omega_g \frac{L_m}{L_r} u_{ry} - R_r \frac{L_m^2}{L_r^2} \omega_g i_{sy} \right) + u'_{sy} \left(\omega_g \frac{L_m}{L_r} u_{rx} + R_r \frac{L_m^2}{L_r^2} \omega_g i_{sx} \right) - \frac{R_r}{L_r} (u'^2_{sx} + u'^2_{sy}) \right] \quad (10)$$

Because of $\tan \delta = \frac{u'_{sy}}{u'_{sx}}$, the voltage phase derivative is

$$\frac{d\delta}{dt} = \frac{1}{\bar{u}'_{sg}} \left[u'_{sx} \left(\omega_g \frac{L_m}{L_r} u_{rx} + R_r \frac{L_m^2}{L_r^2} \omega_g i_{sx} \right) - u'_{sy} \left(-\omega_g \frac{L_m}{L_r} u_{ry} - R_r \frac{L_m^2}{L_r^2} \omega_g i_{sy} \right) - (\omega_g - \omega_r) (u'^2_{sx} + u'^2_{sy}) \right] \quad (11)$$

3.3. Wind generator model considering active and reactive power delivered

By remembering classical expressions of active and reactive powers:

$$P = \frac{3}{2} \operatorname{Re}(\bar{u} \bar{i}^*) = \frac{3}{2} (u_x i_x + u_y i_y) \quad (12)$$

$$Q = \frac{3}{2} \operatorname{Im}(\bar{u} \bar{i}^*) = \frac{3}{2} (u_y i_x - u_x i_y), \quad (13)$$

and considering expressions (10) and (11):

$$\frac{d\bar{U}'_{sg}}{dt} = \frac{1}{\bar{U}'_{sg}} \left[\frac{2}{3} R_r \frac{L_m^2}{L_r^2} \omega_g Q'_s + u'_{sx} \left(-\omega_g \frac{L_m}{L_r} u_{ry} \right) + u'_{sy} \left(\omega_g \frac{L_m}{L_r} u_{rx} \right) - \frac{R_r}{L_r} (u'^2_{sx} + u'^2_{sy}) \right] \quad (14)$$

$$\frac{d\delta}{dt} = \frac{1}{\bar{U}'_{sg}} \left[\frac{2}{3} R_r \frac{L_m^2}{L_r^2} \omega_g P'_s + u'_{sx} \left(\omega_g \frac{L_m}{L_r} u_{rx} \right) - u'_{sy} \left(-\omega_g \frac{L_m}{L_r} u_{ry} \right) - (\omega_g - \omega_r) (u'^2_{sx} + u'^2_{sy}) \right] \quad (15)$$

it is noted, as expected, that the internal voltage derivative is a function of reactive power while its phase depends on the active power. Note also, that active and reactive powers, P'_s and Q'_s respectively, are internal power sources, i.e. they are not the wind generator output powers.

4. Grid flux reference frame

As it was previously indicated, vector control allows controlling machine behaviors in an easier way than others techniques. One of the advantages of properly choosing the reference frame position is that is possible to simplify analysis and control¹ of electrical machines. In this way, virtual flux reference frame is chosen by considering a virtual flux from grid voltage [16,17]:

$$\bar{\psi}_g = \frac{u_s}{j\omega_g} = -j \frac{|u_s| e^{j\theta_g}}{\omega_g}, \quad (16)$$

With θ_g the voltage phase and ω_g the phasor speed. According to Figure 3 the proposed reference frame defines a virtual flux $(\bar{\psi}_g)^o$ away from the voltage grid which belongs to the imaginary axis.

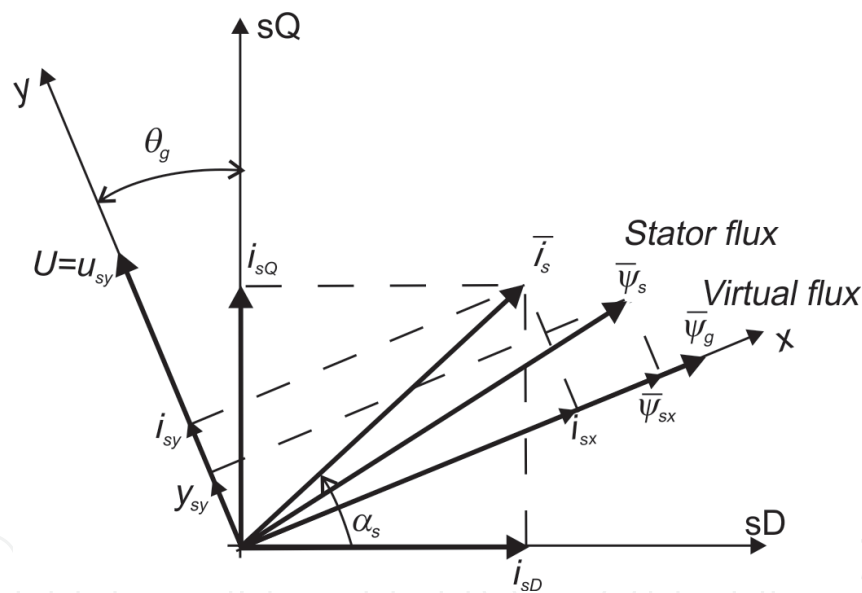

Figure 3. Stationary reference frame sD - sQ and virtual reference frame x - y

Power expressions, by virtue of the chosen reference frame, are:

$$P = \frac{3}{2} \text{Re}(\bar{u}i^*) = \frac{3}{2} (u_x i_x + u_y i_y) = \frac{3}{2} (U i_{sy})$$

$$Q = \frac{3}{2} \text{Im}(\bar{u}i^*) = \frac{3}{2} (u_y i_x - u_x i_y) = \frac{3}{2} (U i_{sx}),$$

¹ Explaining vector control is not the scope of this chapter. About vector control of different kinds of machines see [12] and [15]

where both expressions show the importance of choosing suitably the reference frame. Indeed it is really simple to control active and reactive power from controlling the stator currents in an independent way.

4.1. Squirrel cage machine as a load

According to the previously discussed, it is possible to obtain active and reactive power dynamic models of the induction motors by operating with the presented expressions. These models can be employed in power systems stability studies considering that induction motors are about 60% of all loads [18]. In this way, it is better to begin with the cartesian coordinates already presented and consider a virtual flux reference frame for an induction machine motor. According to Appendix B:

$$P \cong \frac{3U^2 L_m (\omega_g - \omega_r) B}{2R_s L_s \omega_g} - \frac{3U L_m A}{2R_s L_s} \frac{dU}{dt} + \frac{3U^2 L_m A}{2R_s L_s \omega_g} \frac{d\omega_g}{dt} \cong K_{01} U^2 + K_{02} \frac{U^2}{\omega_g + \Delta\omega_g} + K_1 U \frac{dU}{dt} + K_2 \frac{U^2}{\omega_g + \Delta\omega_g} \frac{d\omega_g}{dt}$$

$$Q \cong \frac{\frac{3}{2} U^2}{\omega_g L_s + L_m A \frac{d\omega_g}{dt} + L_m (\omega_g - \omega_r) B} = \frac{\frac{3}{2} U^2}{(\omega_g + \Delta\omega_g) (L_s + L_m B) + L_m A \frac{d\omega_g}{dt} - L_m \omega_r B}$$

In both power expressions $A = \left(L_s - \frac{L_m^2}{L_r} \right) \frac{L_r}{L_m R_r}$, $B = \frac{L_r}{L_m R_r} R_s$, ω_g is the line frequency, $\Delta\omega_g$ is the frequency deviation and ω_r is the rotor speed that, because of rotor inertia, remains practically constant in the temporal interval of interest.

5. Modelling of DFIG's operated with vector control

Variable speed wind farms powered by double fed induction (wound rotor) generators (DFIGs) are the other power plants considered in this chapter. Figura 4 shows the main components of a DFIG wind turbine: the rotor, the mechanical transmission system, the doubly fed induction generator and the back to back converters with their respective controls. In general, converters C1 and C2 are operated in an independent way. Meanwhile C1 is operated via vector control driving active and reactive stator powers, C2 maintains the DC bus voltage constant. In subsynchronous speeds, the rotor of the DFIG machine consumes active power meanwhile at supersynchronous speeds delivers it. As a consequence when considering active power delivered by a DFIG wind generator it should be taking into account the active power in the rotor channel.

Because of DFIG machines control is made via C1 converter, all of this chapter considers only C1 control and avoids analyzing C2 even when its operation is similar.

Beginning with the cartesian model in the general reference frame:

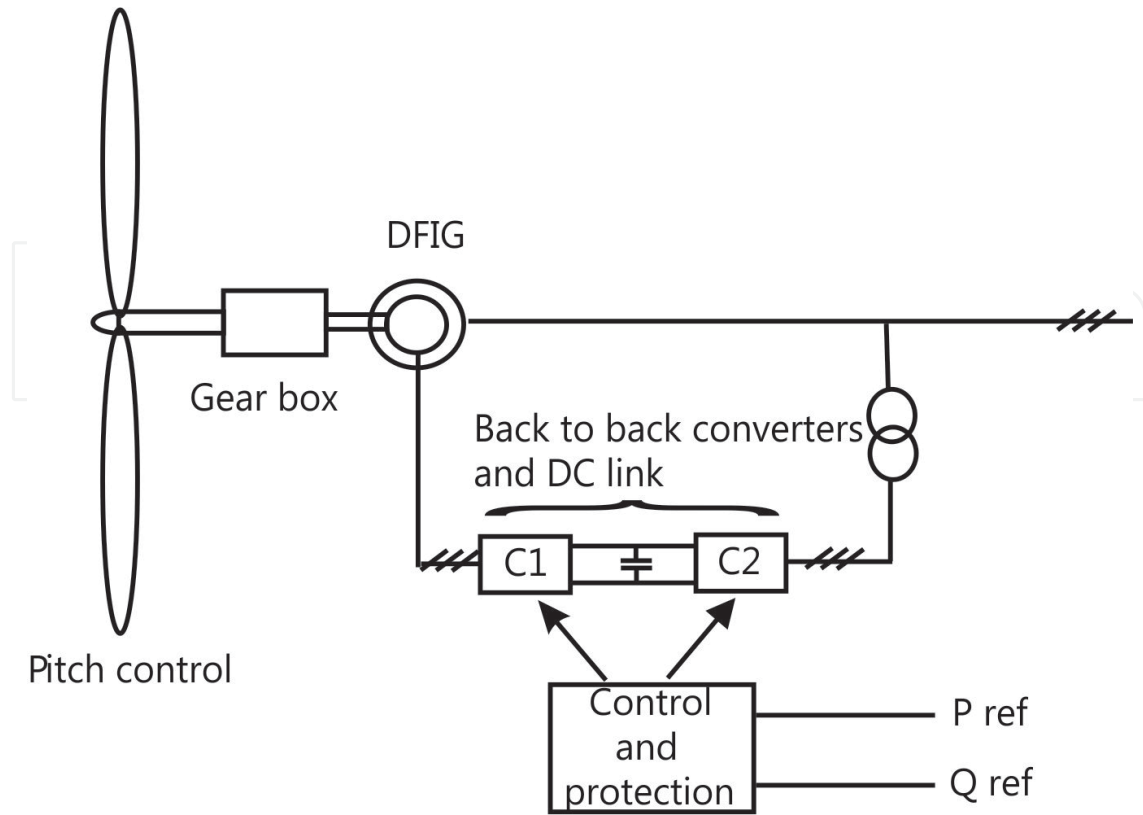

Figure 4. Wind turbine main components

$$\bar{u}'_{sg} = -R_s j \bar{i}'_{sg} + \omega_g \left(L_s - \frac{L_m^2}{L_r} \right) \bar{i}'_{sg} + \bar{u}_{sg} \tag{17}$$

$$\frac{d\bar{u}'_{sg}}{dt} = \omega_g \frac{L_m}{L_r} j \bar{u}_{rg} + R_r \frac{L_m^2}{L_r^2} \omega_g j \bar{i}'_{sg} - (\omega_g - \omega_r) j \bar{u}'_{sg} - \frac{R_r}{L_r} \bar{u}'_{sg} \tag{18}$$

it is noted, due to “j” operator, that there are unwanted coupling terms between rotor and stator circuits along *y* and *x* axes. This coupling can be eliminated by utilizing an additional voltage component $\bar{u}_{rgdec} = \bar{u}_{rgdec1} + \bar{u}_{rgdec2}$ in expression (18), where:

$$\bar{u}_{rgdec1} = -R_r \frac{L_m}{L_r} \bar{i}'_{sg} \tag{19}$$

$$\bar{u}_{rgdec2} = \frac{L_r (\omega_g - \omega_r)}{L_m \omega_g} \bar{u}'_{sg} \tag{20}$$

Both values should be added to the rotor controllers. Note also that, according to (20)

$$\bar{u}_{rgdec2} = \frac{L_r}{L_m} \frac{(\omega_g - \omega_r)}{\omega_g} \bar{u}'_{sg} = \frac{L_r}{L_m} s \bar{u}'_{sg} \cong s \bar{u}'_{sg}$$

with $L_r = L_m + L_{lr} \cong L_{m'}$ s the slip and L_{lr} the leakage inductance. Last expression can be approximated, considering that $z = R_s + j\omega_g \left(L_s - \frac{L_m^2}{L_r} \right)$ in (17) is small. Then, $\bar{u}'_{sg} \cong U$ and \bar{u}_{rg} limits the variable speed range operation in modern DFIGs by approxiimedly 30 slip when considering rotor converter size (nominal voltage=30% U grid).

On the other side, even when the voltage feedforward can avoid the undesired coupling, this is not an optimum solution when expression (19) is seen under next considerations

- it is important to maximize the DFIG variable speed range operation, then some coupling can be tolerated,
- as presented later, looking for mimicking conventional synchronous plants operation and control, it can be useful to use the current input, eliminated by (19), for control purposes.

Figure 5 shows, on the left, a block diagram where undesired voltages are eliminated via the feedforward of the stator voltage and current; on the righth, a simplified equivalent loop where only appears the rotor dynamics. Power references are transformed to rotor voltages ones by vector control [12] indicated as K in Figure 5.

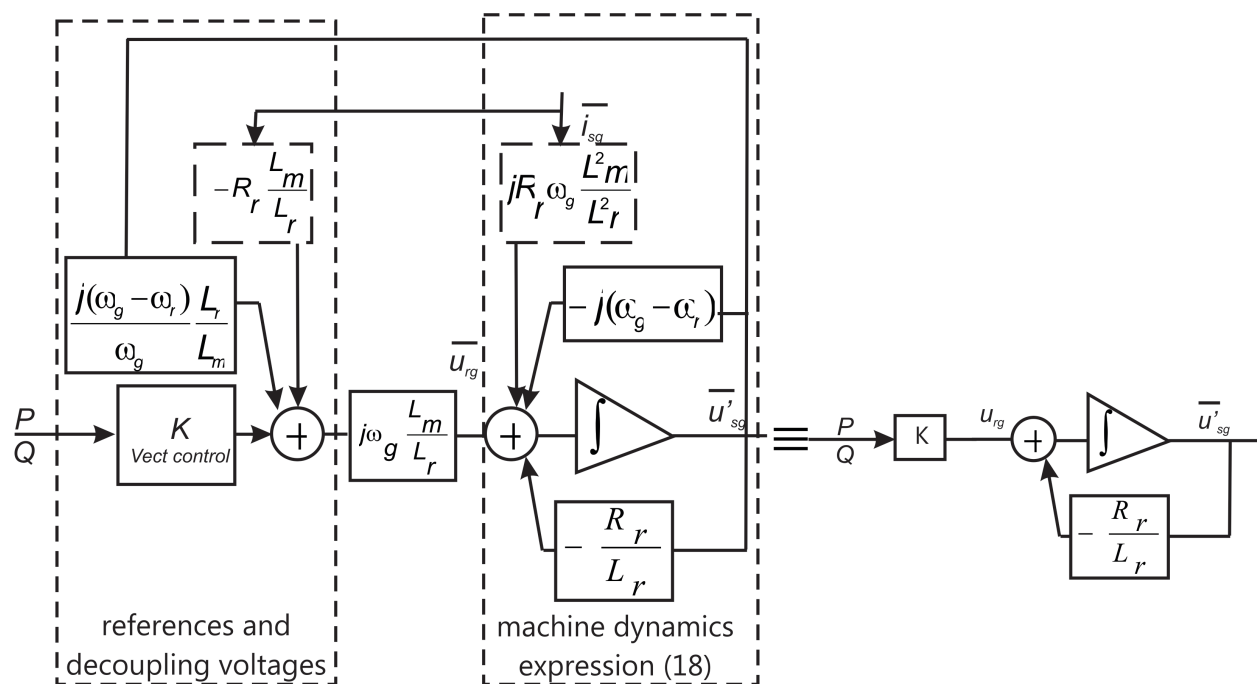

Figure 5. Feed for ward corrections and power references

According to expression (17) and considering $R_s \cong 0$, it is possible to obtain stator currents and, then, delivered powers:

$$i_{sg} = \frac{1}{\left(L_s - \frac{L_m^2}{L_r}\right)\omega_g} (\bar{u}'_{sg} - \bar{u}_{sg})$$

$$P = \frac{3}{2} u_{sy} i_{sy} = \frac{3}{2} \frac{U(\bar{u}'_{sy} - U)}{\left(L_s - \frac{L_m^2}{L_r}\right)\omega_g} \tag{21}$$

$$Q = \frac{3}{2} u_{sy} i_{sx} = \frac{3}{2} \frac{U\bar{u}'_{sx}}{\left(L_s - \frac{L_m^2}{L_r}\right)\omega_g} \tag{22}$$

This completes the machine model which is presented in Figure 6 where Δ represents uncertainties and approximation errors (for example by neglecting R_s or those due to unmatched parameters between the model and the actual machine). After active and reactive powers are measured they are feedback to the controller which is usually a PI one. Note that in vector control (which is presented here by K') there are more than one feedback loop. Indeed, aside from decoupling voltages (Figure 5) there are two rotor current loops with the external ones for active and reactive powers control in Figure 6.

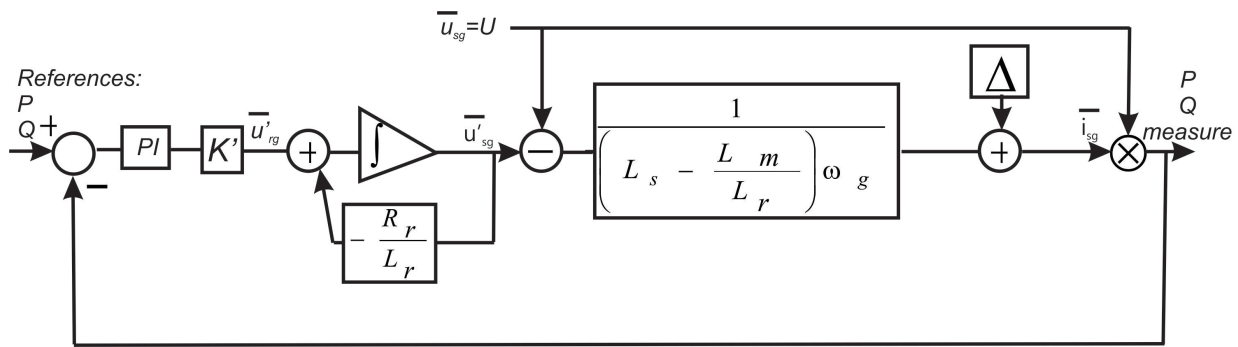

Figure 6. Decoupled model. External loop for active and reactive power control

6. Static models of asynchronous machines

It is well known that some model simplifications, keeping a good compromise between behavior and results exactitude, allow a better qualitative understanding of different kind of processes. An example of this appears studying mechanical behaviors of a wind turbine in presence of a wind velocity change. In this case, and beginning from a steady state condition, electrical behavior can be considered significantly faster than the mechanical response.

In this way, the dominant mode is the mechanical one and the electrical modes can be omitted (the stator transitory can be neglected as done in this chapter).

This section obtains the static model of induction machines derived from the dynamic one already presented. Obviously, there will always be time frames in which none of the models presented in this chapter is the best one to analyze a particular problem. In this way, if it is of importance to study the stator transitory of electrical machines, obviously, this dynamic can not be neglected as in this chapter was done. In any case, the importance of determining which model is more adequate to analyze a particular situation always lies in the physical knowledge underlying the problem.

6.1. Polar coordinates

Beginning with the dynamic model:

$$\bar{u}'_{sg} = -R_s j \dot{i}_{sg} + \omega_g \left(L_s - \frac{L_m^2}{L_r} \right) \dot{i}_{sg} + \bar{u}_{sg}$$

$$\frac{d\bar{u}'_{sg}}{dt} = \omega_g \frac{L_m}{L_r} j \bar{u}_{rg} + R_r \frac{L_m^2}{L_r^2} \omega_g j \dot{i}_{sg} - (\omega_g - \omega_r) j \bar{u}'_{sg} - \frac{R_r}{L_r} \bar{u}'_{sg} =$$

then:

$$\bar{U}'_{sg} = \sqrt{u'^2_{sx} + u'^2_{sy}} \text{ and } \delta = \arctan\left(\frac{u'_{sy}}{u'_{sx}}\right)$$

6.2. Static model as a function of the active and reactive stator powers delivered in the virtual flux reference frame

The voltage internal phase:

$$\tan\delta = \frac{u'_{sy}}{u'_{sx}}$$

$$\tan\delta = \frac{-R_s Q + \omega_g \left(L_s - \frac{L_m^2}{L_r} \right) P + \frac{3}{2} U^2}{R_s P + \omega_g \left(L_s - \frac{L_m^2}{L_r} \right) Q}$$

is highly dependent on grid voltage, on active power and, in a lesser way, on reactive power. Note that, if a DFIG is operated at unitary power factor, i.e. $Q=0$, then $\delta \cong 90^\circ$.

On the other side, the internal voltage results:

$$\bar{U}'_{sg} = \sqrt{u'^2_{sx} + u'^2_{sy}} = u'_{sy} \sqrt{\cot^2 \delta + 1} = \frac{u'_{sy}}{\sin\delta} \Rightarrow$$

$$\overline{U}'_{sg} = \frac{-R_s \frac{2}{3} Q + \omega_g \left(L_s - \frac{L_m^2}{L_r} \right) \frac{2}{3} P + U^2}{U \sin \delta}$$

$$\overline{U}'_{sg} = \sqrt{u'^2_{sx} + u'^2_{sy}} = u'_{sx} \sqrt{\tan^2 \delta + 1} = \frac{u'_{sx}}{\cos \delta} \Rightarrow$$

$$\overline{U}'_{sg} = \frac{R_s \frac{2}{3} P + \omega_g \left(L_s - \frac{L_m^2}{L_r} \right) \frac{2}{3} Q}{U \cos \delta}$$

7. Wind farm control

Wind farms have become a visible component of interconnected power grids. In the beginnings of wind generation, when a low portion of the electrical power was delivered from this renewable energy, only simple engineering judgment were necessary to conclude about the negligible impact of wind generation on power systems. Nowadays, with wind farms, but also with high power wind generators in dispersed grids, approaching the output rating of conventional power plants, it is necessary understanding the way in which wind generation can impact and/or contribute to the power system stability.

This section presents different wind farms controls by considering them as current sources and voltages sources (Thevenin equivalent) in an effort for mimicking conventional generation.

The proposed wind farm control approaches are based in the named Lyapunov Theory which give place to linear and non linear wind farm controls. In these approaches, the DFIG capability for controlling active and reactive powers plays an important role in contributing to power system stability. Then, from here on, only DFIG wind farms are considered.

Additionally, Energy (Lyapunov) approach is not based on system linearization and the proposed analysis allows considering any wind farm in any power system in the same way avoiding transform every issue about integrating wind farms in power systems in a different problem.

As indicated, in order to contribute to the network stability, both active and reactive wind farm power controls of a wind farm are considered. Then, steady state controls (normal operating conditions) plus incremental corrections are proposed:

$$Q_{wf} = Q_{SC} + \Delta Q,$$

$$P_{wf} = P_{SC} + \Delta P.$$

with P_{wf} (Q_{wf}) is the total active (reactive) power, P_{SC} (Q_{SC}) the power reference given by a Supervisory Control [19,20] and ΔP (ΔQ) the wind farm correction which contributes to the power system stability.

Note that for both active and reactive corrective actions some power reserve is required. Indeed, about active power it will be expected a power reserve which is a function of the wind turbine operating point and about the reactive power correction, the total 'apparent' power of the DFIG machine will limit the corrective action.

7.1. Wind farm aggregated model

A complete model of a wind farm with a high number of wind generators, may lead to compute an excessive and impractical number of equations. The size of the wind farm model may be reduced by aggregating several wind turbines with similar incoming wind into a bigger turbine called aggregated turbine [14]. The mechanical and electric parameters per unit are preserved, and the nominal power is increased up to the sum of the nominal power of the whole set of turbines to obtain the parameters of the aggregated turbine. This procedure is employed in this chapter where the wind farm is modeled as one aggregated wind turbine. In this regard, the Thevenin equivalent can be obtained as in a classical problem of electrical systems, applying precisely Thevenin theorem, being the internal voltage and its phase calculated according to the impedance and voltage seen from the wind farm common connection point.

7.2. Wind farm control. Method of Lyapunov

Power system stability has been defined as that property of a power system that enables it to remain in a state of operating equilibrium under normal operating conditions and to regain an acceptable state of equilibrium after being subjected to a disturbance [5].

Lyapunov demonstrated that a nonlinear dynamic system:

$$\dot{x} = f(x), \quad f(0) = 0, \quad (23)$$

around the equilibrium point $x=0$ is asymptotically stable if there exist a scalar function $v(x)>0$ for (23) with derivative $\dot{v}(x)<0$. The last condition is relaxed to $\dot{v}(x)\leq 0$ provided that $\dot{v}(x)=0$ only vanish at $x=0$.

Lyapunov theory deals with dynamical systems without inputs. However, it is possible to employ Lyapunov theory in feedback design by making negative the Lyapunov derivative [21,22,23]. The incremental energy function v of a power system without wind farms, where conventional models of the synchronous generators and of load impedance are considered, is [23]:

$$v = \sum_{k=1}^{N_G} (0.5M_k \tilde{\omega}_k^2 - P_{Mk} \tilde{\delta}_k) + \sum_{k=1}^{N_L} (P_{Lk} \tilde{\theta}_k + \int \frac{Q_{Lk}}{V_k} dV_k), \quad (24)$$

with

$$\tilde{\omega}_k = \omega_k - \omega_{COI}, \quad \omega_{COI} \doteq \frac{1}{M_T} \sum_{k=1}^m M_k \omega_k,$$

$$\tilde{\delta}_k = \delta_k - \delta_{COI}, \quad \delta_{COI} \doteq \frac{1}{M_T} \sum_{k=1}^m M_k \delta_k,$$

$$\tilde{\theta}_k = \theta_k - \delta_{COI}, \quad M_T \doteq \sum_{k=1}^m M_k,$$

with N_L and N_G the number of loads and generators, M_k the machine inertia constant, ω_k the machine speed, δ_k the angle of the voltage behind the transient reactance, θ_k the angle at each bus, P_{M_k} the mechanical power of the generators, P_{Lk} and Q_{Lk} the active and reactive load powers and V_k the voltage at the connection point. The angles and speeds are measured with respect to the center of inertia (COI) reference frame (δ_{COI} and ω_{COI}).

7.2.1. Non-linear power control of wind farms as negative loads

To damp the electromechanical oscillations, i.e. frequency oscillations, the incremental energy function of the power system must decrease. The time derivative of this energy function considering wind farms as negative loads, i.e. acting through its active and reactive powers, yields:

$$\dot{v} = \sum_{k=1}^{N_G} (M_k \dot{\omega}_k^2 + P_{Gk} - P_{Mk}) \dot{\delta}_k + \sum_{n=1}^{N_L} P_n \dot{\theta}_n + \sum_{n=1}^{N_L} \frac{\dot{V}_n}{V_n} Q_n - \frac{\dot{V}_{wf}}{V_{wf}} \Delta Q - \Delta P \dot{\theta}_{wf}. \quad (25)$$

Then, the active and reactive powers (ΔP and ΔQ) must be chosen in order to allow the sufficient condition of the derivative of the incremental energy function. In equation (25), the expression in between parenthesis is zero (or lesser than zero) because of the generators power balance (equals the internal generator damping). The next two terms correspond to the power balance equations at the nodes and are zero. Then, looking for damping the electromechanical oscillations, the last two expressions must be less than zero.

About the active power two possibilities are chosen [10]:

$$\Delta P = K_{c1} \dot{\theta}_{wf}; \quad \text{with } K_{c1} > 0, \quad (26)$$

$$\Delta P = K_{c2} \ddot{\theta}_{wf}^2 \dot{\theta}_{wf}; \quad \text{with } K_{c2} > 0. \quad (27)$$

meanwhile the first expression which is the classical proportional frequency law, the second one is a kind of inertial response. Indeed, the second expression can be understood as a modification of (26) where K_{c1} is a variable gain $K_{c1} = K_{c2} \dot{\theta}_{wf}^2$ which takes into account frequency derivative.

On the other hand, a non-linear control strategy of the wind farm through the reactive power ΔQ can be derived from expression (25) by considering that the wind farm emulates the behavior of a static var compensator:

$$\Delta Q = b_u V_{wf}^2 \Rightarrow$$

$$-\frac{\dot{V}_{wf}}{V_{wf}} \Delta Q = -b_u V_{wf} \dot{V}_{wf} = -\frac{1}{2} b_u \frac{d}{dt} V_{wf}^2.$$

In this way, in order to keep the sufficient condition, some possibilities arise:

$$b_u = K_r \frac{dV_{wf}^2}{dt}; \text{ with } K_r > 0 \text{ or} \quad (28)$$

$$b_u = K_r \text{sign} \left(\frac{dV_{wf}^2}{dt} \right); \text{ with } K_r > 0, \quad (29)$$

Where b_u is the (equivalent) wind farm susceptance.

With respect to the active power control, note that the idea of a power reserve, as a percentage of the maximum available power, is very attractive from a point of view of the network stability and it is usually employed [19,20]. However, suppose that $\Delta P = 0$, the appropriate choice of the reactive power function (expressions (28) or (29)) implies that the energy function derivative (34) almost always decreases, i.e. any electromechanical oscillation is damped. Then, the wind farm reactive power contributes to damp the electromechanical oscillations of the power system. Being, in general, $\Delta P \neq 0$, the reactive power function reinforces the wind farm contribution to the network stability.

Note that, with both active and reactive control laws, it is possible maximizing the use of the energy resource in order to contribute to damp the electromechanical oscillations by exploiting all the capabilities of the DFIG machines. In this way, it is possible designing a control law for the reactive power which takes into account the advantage of producing as much reactive power as possible considering the apparent power of the DFIGs.

7.2.2. Non-linear active power control of wind farms as Thevenin equivalent

Due to it is expected that wind farms act as power plants [24], it is necessary to demonstrate that wind farms behave as their equivalent synchronous generators (the conventional power plants) with proportional and derivative (inertial) frequency control laws. The equations representing the dynamic behavior of synchronous generators for the reduced model, are [5]:

$$\dot{\delta}_k = \tilde{\omega}_k, \quad (30)$$

$$\dot{\tilde{\omega}}_k = \frac{1}{M_k} (P_{mk} - D_k \omega_k - P_{Gk}). \quad (31)$$

where M_k is the inertia of the whole machine (synchronous generator plus prime mover), P_{mk} is the mechanical power produced by the prime mover, D_k is the component of internal friction of the generator and P_{Gk} is the electrical power injected in the network. Because of variables are in per unit, powers and torques are equal [5]. Mimicking the analysis for a wind farm with frequency control and inertial contribution yields [19]:

$$\dot{\tilde{\alpha}}_k = \Omega_{gk}, \quad (32)$$

$$\dot{\tilde{\Omega}}_{gk} = \frac{1}{M_{gk}}(P_t - P_{wf}), \quad (33)$$

with P_t the turbine power.

Considering the control as:

$$P_{wf} = P_{SC} + \Delta P,$$

$$\Delta P = K_p(\tilde{\omega}_{ref} - \tilde{\omega}) + K_d(\dot{\tilde{\omega}}_{ref} - \dot{\tilde{\omega}}) = K_p\omega + K_d\dot{\omega},$$

where is included a PD control named “proportional and inertial” classical control laws, then:

$$\dot{\tilde{\omega}} = \frac{1}{K_d}(P_t - (K_p\tilde{\omega} + M\dot{\tilde{\Omega}}_{gk}) - P_{SC}). \quad (34)$$

Note the similarity of this expression with (31) for synchronous generation. Then, the analysis focuses on addressing the control of the wind farm as in \dot{v}_1 which considers the derivative of the Energy Function of a synchronous generator in (34):

$$v_1 = \sum_{k=1}^{N_G} (M_k \tilde{\omega}_k^2 + P_{Gk} \tilde{\theta}_k - P_{Mk} \tilde{\theta}_k) \Rightarrow \dot{v}_1 = \sum_{k=1}^{N_G} (-D \tilde{\omega}_k) < \quad (35)$$

The equivalent expression for a wind farm is:

$$v_{1wf} = \omega_k^2 + \frac{P_{SC}}{K_d} \tilde{\theta}_{wf} - \frac{P_t}{K_d} \tilde{\theta}_{wf} \Rightarrow \dot{v}_{1wf} = \omega_k \dot{\omega}_k + \frac{P_{SC} - P_t}{K_d} \dot{\tilde{\theta}}_{wf} = \left(\omega_k + \frac{P_{SC} - P_t}{K_d} \right) \dot{\tilde{\theta}}_{wf},$$

$$\dot{v}_{1wf} = \left(-\frac{M_{wf}}{K_d} \dot{\tilde{\Omega}}_g - \frac{K_p}{K_d} \tilde{\omega} \right) \dot{\tilde{\theta}}_{wf} = -\frac{M_{wf}}{K_d} \dot{\tilde{\Omega}}_g \dot{\tilde{\theta}}_{wf} - \frac{K_p}{K_d} \dot{\tilde{\theta}}_{wf}^2, \quad (36)$$

being $K_p > 0$ and $K_d > 0$ it is verified the negative sign of the second term in the last expression.

On the other side, in order to verify the negative sign of $-\frac{M_{wf}}{K_d} \dot{\Omega}_g \dot{\theta}_{wf}$ it is necessary to analyse the wind farm convergence to an equilibrium point (e.p.), knowing that $M_{wf} > 0$ and considering that the wind farm (the aggregated turbine) is outside the equilibrium point.

Figure 7 presents the torque - speed curves of the aggregated wind turbine with the wind velocity as a parameter. The e.p., considering constant wind velocity, corresponds to nominal frequency at the wind farm connection point with constant shaft speed $\Omega_{e.p.}$ of the aggregated turbine.

In order to verify the convergence to the equilibrium, two conditions outside the e.p. [19], which are consequence of electrical disturbances, will be analyzed. First, consider that because of a disturbance action, the aggregated wind turbine is operating at point A (Figure 7)

with $\Omega_A < \Omega_{e.p.}$, being the frequency $\dot{\theta}_A < \dot{\theta}$. At that point, the wind farm generated power is higher than the nominal one, i.e. the wind farm is contributing to restore the frequency at the connection point.

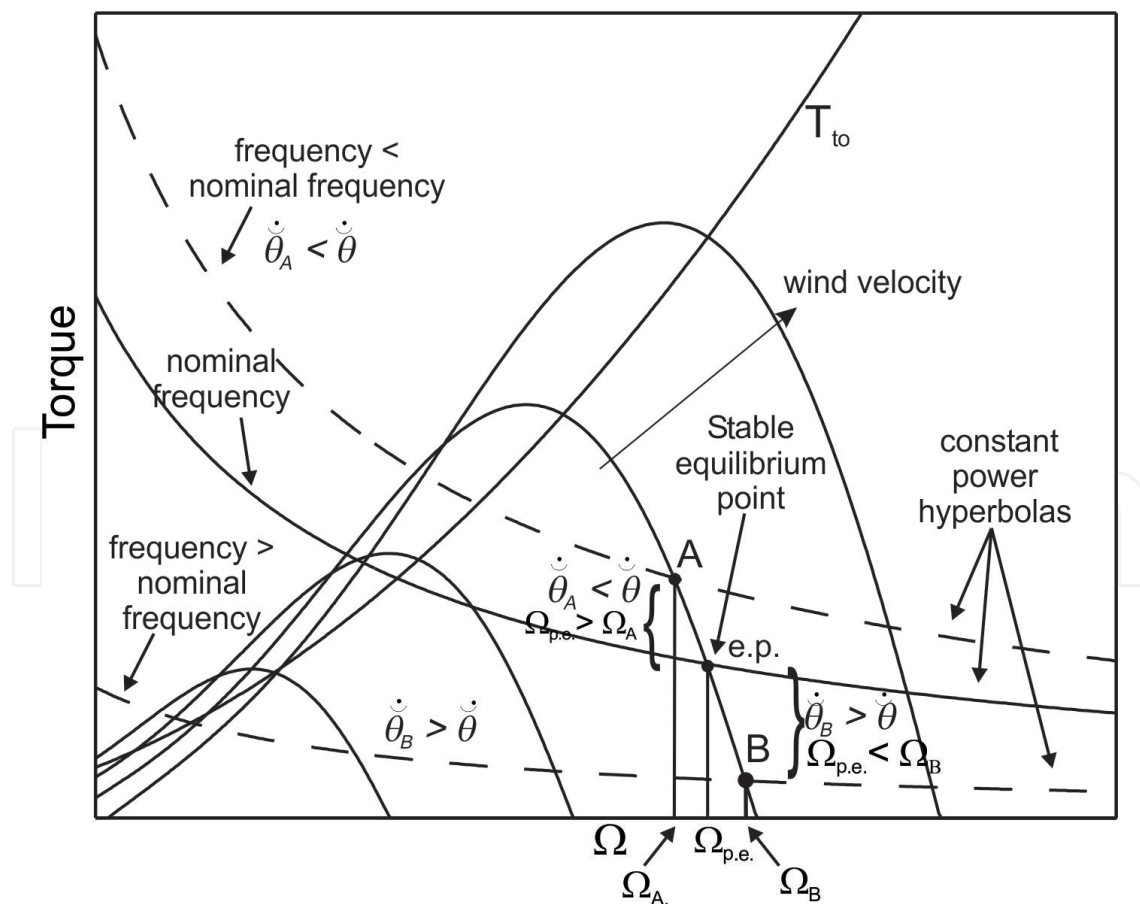

Figure 7. Torque - speed characteristics. Convergent behaviour to the e.p.

When the disturbance disappears, the network returns to its normal configuration and the wind farm power is higher than that which maintains the power balance in the system. As the deviation of the frequency decreases, so does the wind farm generated power. As a consequence, the wind turbine torque decreases and the turbine speed experiences an increment until the speed reaches $\Omega_{p.e.}$. Thus, while the frequency reaches their nominal value, the wind turbine increasing its speed. Then, the (negative) sign of (36) is verified by considering:

$$\dot{\theta}_{wf} = \dot{\theta}_{ref} - \dot{\theta}_A > 0 \quad \text{and} \quad (37)$$

$$\dot{\Omega}_g = \frac{\Omega_{e.p.} - \Omega_A}{\Delta t} > 0. \quad (38)$$

If as a consequence of another disturbance the aggregated turbine is operating at point B (Figure 7), when the disturbance is removed the sign of (36) yields:

$$\dot{\theta}_{wf} = \dot{\theta}_{ref} - \dot{\theta}_A < 0 \quad \text{and} \quad (39)$$

$$\dot{\Omega}_g = \frac{\Omega_{e.p.} - \Omega_B}{\Delta t} < 0. \quad (40)$$

Expressions (38) and (40) verify the negative sign of (36).

7.2.3. Non-linear reactive power control of wind farms from the Thevenin equivalent

In last subsection, by mimicking the reduced model of conventional synchronous generators with wind farms, it has been deduced that wind farms PD laws, i.e. the named frequency and inertial responses control approaches, allows to contribute to the power system stability. In order to deduce a wind farm reactive power control, it is necessary to include the named "Structure Preserving the Model" [21] or "the one axis model" [6] for the conventional synchronous generators. The dynamics of a k -th synchronous generator, respect to the COI is [21]:

$$\ddot{\delta}_k = \tilde{\omega}_k, \quad (41)$$

$$M_k \dot{\tilde{\omega}}_k = P_{mk} - D_k \omega_k - P_{Gk} - \frac{M_k}{M_T} P_{COI} \quad (42)$$

$$T'_{d0k} \frac{dE'_{qk}}{dt} = \frac{x_{dk} - x'_{dk}}{x'_{dk}} V_{n+k} \cos(\delta_k - \theta_{n+k}) + E_{fdk} - \frac{x_{dk}}{x'_{dk}} E'_{qk} \quad (43)$$

being T'_{d0k} the d axis transient open circuit time constant; E'_{qk} the q axis voltage behind transient reactance, E'_{fdk} is the exciter voltage which is assumed constant (if the exciter control action is included in the generator model, at least one additional dynamic expression should be included) and x_{dk} and x'_{dk} are d axis synchronous reactance and transient reactance, respectively.

An advantage of this model when compared to the classical one with two states (expressions (30) and (31)) is the possibility of including loads where the impedance are not constant. In order of making more clear the explanation it will not be included any wind farm in this step. According to [21] next terms are added to the already applied Lyapunov function:

$$v_{2a} = \sum_{i=n+1}^{2n} \frac{1}{2x'_{di-n}} [E'^2_{qi-n} + V_i^2 - 2E'_{qi-n} V_i \cos(\delta_{i-n} - \theta_i)]$$

$$v_{2b} = - \sum_{i=1}^n \frac{E_{fdi} E'_{qi}}{x_{di} - x'_{di}},$$

$$v_{2c} = \sum_{i=1}^n \frac{E'^2_{qi}}{(x_{di} - x'_{di})},$$

$$v_{2d} = - \frac{1}{2} \sum_{i=n+1}^{n+N} \sum_{l=n+1}^{n+N} B_{kl} V_k V_l \cos(\theta_i - \theta_l)$$

$$v_{2e} = \sum_{i=n+1}^{2n} \frac{x'_{di-n} - x_{di-n}}{4x'_{di-n} x_{di-n}} [V_i^2 - V_i^2 \cos((\delta_{i-n} - \theta_i))]$$

Then, the derivative of the (new) Lyapunov function is:

$$\dot{v} = \sum_{k=1}^{N_G} (M_k \dot{\tilde{\omega}}_k^2 + P_{Gk} - P_{Mk}) \dot{\delta}_k + \sum_{n=1}^{N_L} P_n \dot{\theta}_n + \sum_{n=1}^{N_L} \frac{\dot{V}_n}{V_n} Q_n + \dot{v}_{2a} + \dot{v}_{2b} + \dot{v}_{2c} + \dot{v}_{2d} + \dot{v}_{2e}$$

$$\dot{v} = - \sum_{k=1}^{N_G} D_k (\dot{\tilde{\omega}}_k^2) - \sum_{k=1}^{N_G} \frac{T'_d}{x_d - x'_d} \dot{E}'_q{}^2,$$

where:

$$\sum \left(P_n \dot{\theta}_n + \frac{\partial v_{2a}}{\partial \theta_n} \dot{\theta}_n + \frac{\partial v_{2d}}{\partial \theta_n} \dot{\theta}_n + \frac{\partial v_{2d}}{\partial \theta_n} \dot{\theta}_n \right) = \sum (P_n + P_k) \dot{\theta}_n = 0$$

$$\sum \left(\frac{\dot{V}_n}{V_n} Q_n + \frac{\partial v_{2a}}{\partial V_n} \dot{V}_n + \frac{\partial v_{2d}}{\partial V_n} \dot{V}_n + \frac{\partial v_{2d}}{\partial V_n} \dot{V}_n \right) = \sum (Q_n + Q_k) \frac{\dot{V}_n}{V_n} = 0$$

i.e. the total active and reactive powers (consumed plus injected) is zero.

When it is considered the last state variable, the voltage behind transient reactance E'_{qk} , in the derivative of the Lyapunov function:

$$\dot{v}_3 = \frac{\partial v_{2a}}{\partial E'_q} \frac{dE'_q}{dt} + \frac{\partial v_{2b}}{\partial E'_q} \frac{dE'_q}{dt} + \frac{\partial v_{2c}}{\partial E'_q} \frac{dE'_q}{dt} = - \sum_{k=1}^{N_G} \frac{T'_d}{x_d - x'_d} \dot{E}'_q{}^2$$

Due to $T'_d > 0$ and $x_d > x'_d$ the Lyapunov condition is met.

Mimicking the third state equation of the Structure Preserving Model with the aggregated wind turbine (with DFIGs) implies taking dynamical expressions from (18) and eliminating an undesired coupling:

$$\frac{d\bar{u}'_{sg}}{dt} = \omega_g \frac{L_m}{L_r} j\bar{u}_{rg} + R_r \frac{L_m^2}{L_r^2} \omega_g j\bar{i}_{sg} - (\omega_g - \omega_r) j\bar{u}'_{sg} - \frac{R_r}{L_r} \bar{u}'_{sg} \quad (44)$$

$$T_r \frac{d\bar{u}'_{sg}}{dt} = \frac{L_m^2}{L_r} \omega_g j\bar{i}_{sg} + \omega_g \frac{L_m}{R_r} j\bar{u}_{rg} - \bar{u}'_{sg} \quad (45)$$

According to virtual flux control, i_{sy} controls active power meanwhile i_{sx} can be used for reactive power control ($Q = \frac{3}{2} u_{sy} i_{sx}$). Operating with expression (45):

$$T_r \frac{du'_{sy}}{dt} = \frac{L_m^2}{L_r} \omega_g i_{sx} + \omega_g \frac{L_m}{R_r} u_{rx} - u'_{sy}$$

$$T_r \frac{du'_{sy}}{dt} = (L_s - L_{eq}) \omega_g i_{sx} + \omega_g \frac{L_m}{R_r} u_{rx} - u'_{sy}$$

and considering, expression (8), that $L_{eq} = \left(L_s - \frac{L_m^2}{L_r} \right)$.

According to Figure 8, which presents the Thevenin equivalent and the corresponding phasor diagram, and considering expression (17) with $R_s \cong 0$, results:

$$\begin{aligned} i_{sx} &= \frac{1}{L_{eq} \omega_g} (\bar{u}'_{sx} - \bar{u}_{sx}) = \frac{\bar{u}'_{sx}}{L_{eq} \omega_g} = \frac{V \sin(\delta - \theta)}{L_{eq} \omega_g} \\ i_{sx} &= \frac{V \cos[90 - (\delta - \theta)]}{L_{eq} \omega_g} \end{aligned}$$

Then,

$$T_r \frac{du'_{sy}}{dt} = \frac{(L_s - L_{eq})}{L_{eq}} V \cos[90 - (\delta - \theta)] + \omega_g \frac{L_m}{R_r} u_{rx} - u'_{sy}$$

wind farm frequency remains constant due to that measure is taken in the center of 'bouncing' between areas. Indeed, in Figure 9(b) wind farm is located in the COI of the system, then $\tilde{\omega}_k = \omega_k - \omega_{COI} = \omega_{COI} - \omega_{COI} = 0$

Note that the power system in Figure 9 can be analyzed as an academic subject of study due to actual symmetrical systems will always have differences which will be enough to allow that classical control laws contribute to the power system stability. In this cases, obviously, the Lyapunov control laws derived in this chapter could be less effective than other ones which take into account the nature of this electrical grid.

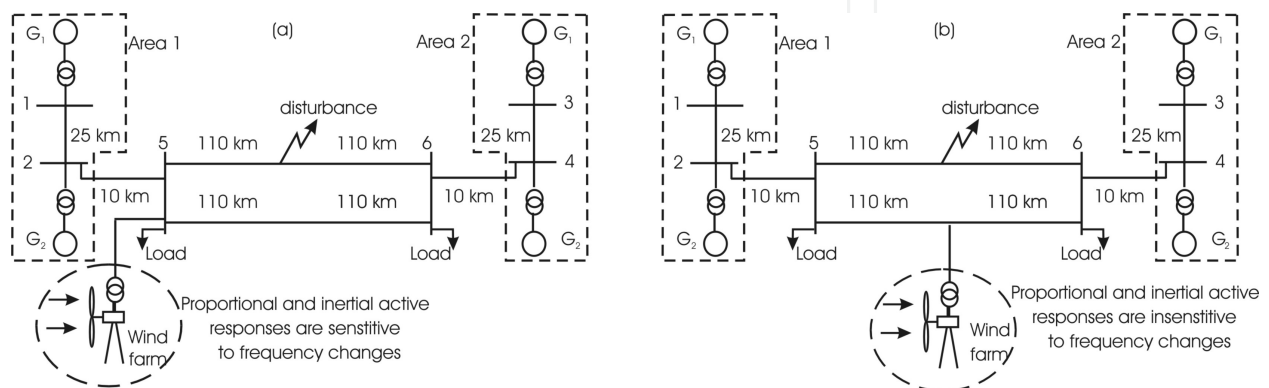

Figure 9. Example considering different wind farm locations with only active power correction based on frequency measures. (a) Effective wind farm correction from proportional and derivative (inertial) actions; (b) Ineffective wind farm active correction

About grids with symmetrical topologies, Passivity theory [25,26,27] can allow to consider some other tools looking for contributing to the power system stability [28,29]. Because of Passivity considers finding a controller in such a way the dynamical system energy function takes the desired form ('energy shaping') and lately considering a power shaping approach, but also solving an energy function which qualifies as a Lyapunov function, Passivity theory implies an important step ahead in the power systems study. Some authors attempts about including wind farm control in the passivity frame can be found in [30,31].

9. Conclusions

This chapter can be divided in two parts, meanwhile the first one is devoted of exploring models and developing a Thevenin equivalent of squirrel cage induction generators (fixed wind generators) and DFIG ones (variable speed generators), after introducing an aggregated wind farm concept and considering a wind farm as another Thevenin equivalent, the second part of the chapter considers analyzing DFIG wind farm linear and non linear control.

The final objective of the chapter is to demonstrate that can be developed an equivalent behavior of wind farms to their counterparts, the synchronous conventional generators, by properly controlling wind farms. This point of view will help to promote wind farm integra-

tion but, at the same time, it will open new doors on contributing to the power systems stability via wind farms control.

About the first part, induction machines models were presented including an additional dynamic model of a squirrel cage induction machine as a load. Additionally, even when vector control was not explained, a control perspective was adopted in showing the way in that stator currents (and powers) can be controlled from rotor voltages in DFIG machines. Also, by considering active and reactive powers delivered for wind generators as input, a static model of induction machines was derived from its dynamical counterpart.

About controlling wind farms, it was possible maximizing the use of the energy resource in order to contribute to damp the electromechanical oscillations by exploiting all the capabilities of the DFIG machines. In this way, wind farms were operated under a Supervisory Control which imposed steady states power references and (added) corrective actions, under Lyapunov Theory which was shortly explained, were proposed as a complement of the references ones.

By considering wind farms as negative loads the Lyapunov frame showed that meanwhile wind farm proportional active power control law was the same as the classical proposed one, about the inertial effect a modification from that one was found. About reactive power, wind farms emulated the behavior of static VAR compensators giving place to a highly non linear control law.

By considering wind farms as voltage sources the Lyapunov frame demonstrated that classical active power laws, proportional and derivative with frequency, can contribute to the power system stability. Also, about reactive power, it was possible demonstrating that wind farms can contribute to damping electromechanical oscillations by controlling its internal (Thevenin) voltage via rotor voltage actions in DFIGs.

As a consequence of the Energy (Lyapunov) approach, the obtained control laws were not based on the linearization of the system. This assures a bigger domain of attraction of the wind farm contribution indicating that, even under severe disturbances, the proposed control laws will contribute to the power system stability.

It is important to note the local nature of the signals used for control laws which avoids any coordination with the rest of the system. Additionally, the damping is not dependent on the power flow direction and neither the kind of failures on the power system.

However, aside from Energy Functions included only some kind of loads and that line resistances must be neglected in the calculus of the functions, another limitation can be found from considering some power systems and wind farms locations where active (or reactive) power control laws can not be effective on contributing to the system stability.

Looking for solving some of the aforementioned drawbacks, future research in Lyapunov topics were indicated but also other perspective, which in fact calculates Energy Functions in control systems, as Passivity was proposed. In this way, the same border conditions re-

main for future control laws as the necessity of local uncoordinated measures, independency of power system topology, robustness, etc.

Finally, it is important to note some differences faced when looking for control laws in power systems. Electrical grids have distinctive characteristics when compared with other "conventional" control systems. In first place, as indicated, the necessity and importance of uncoordinated and robust control laws which contribute to the whole system stability but based from local measures. In second place, wind farm control laws must cover an important range of applications by considering different power systems and different places in which a wind farm can be connected. Indeed, control systems teach us that it is of fundamental importance knowing the "system model", however that model is highly changing and it has infinite equilibrium points when talking about power systems. All of these characteristics only emphasize that power systems are difficult to control and as technology evolves they are upgraded in such a way that some challenges are solved and, at the same time, new ones appear.

Appendix A

Beginning with the expressions in the general reference frame and neglecting stator dynamics ($d\bar{\psi}_{sg}/dt=0$) [5,13,14]:

$$\bar{u}_{sg} = R_s \bar{i}_{sg} + j\omega_g \bar{\psi}_{sg} \quad (46)$$

$$\bar{u}_{rg} = R_r \bar{i}_{rg} + \frac{d\bar{\psi}_{rg}}{dt} + j(\omega_g - \omega_r) \bar{\psi}_{rg} \quad (47)$$

with

$$\begin{aligned} \bar{\psi}_{sg} &= L_s \bar{i}_{sg} + L_m \bar{i}_{rg}; \bar{\psi}_{rg} = L_r \bar{i}_{rg} + L_m \bar{i}_{sg} \Rightarrow \\ \bar{i}_{rg} &= \frac{\bar{\psi}_{rg} - L_m \bar{i}_{sg}}{L_r} \text{ and } \bar{\psi}_{sg} = \left(L_s - \frac{L_m^2}{L_r} \right) \bar{i}_{sg} + \frac{L_m}{L_r} \bar{\psi}_{rg} \end{aligned}$$

which replaced in expression (46) gives

$$\bar{u}_{sg} = \left[R_s + j\omega_g \left(L_s - \frac{L_m^2}{L_r} \right) \right] \bar{i}_{sg} + j\omega_g \frac{L_m}{L_r} \bar{\psi}_{rg} \Rightarrow \bar{u}_{sg} = \left[R_s + j\omega_g \left(L_s - \frac{L_m^2}{L_r} \right) \right] \bar{i}_{sg} + \bar{u}'_{sg} \Rightarrow$$

$$\bar{u}'_{sg} = - \left[R_s + j\omega_g \left(L_s - \frac{L_m^2}{L_r} \right) \right] j \bar{i}_{sg} + \bar{u}_{sg} \quad (48)$$

where \bar{u}'_{sg} is the internal voltage source and the associated impedance is $\left[R_s + j\omega_g \left(L_s - \frac{L_m^2}{L_r} \right) \right]$. Also, from expression (47):

$$\begin{aligned} \bar{u}_{rg} &= R_r \dot{i}_{rg} + \frac{d\bar{\psi}_{rg}}{dt} + j(\omega_g - \omega_r)\bar{\psi}_{rg} = R_r \frac{\bar{\psi}_{rg} - L_m \dot{i}_{sg}}{L_r} + \frac{d\bar{\psi}_{rg}}{dt} + j(\omega_g - \omega_r)\bar{\psi}_{rg}, \\ \frac{d\bar{\psi}_{rg}}{dt} \cdot j\omega_g \frac{L_m}{L_r} &= \left[\bar{u}_{rg} + R_r \frac{L_m}{L_r} \dot{i}_{sg} - R_r \frac{\bar{\psi}_{rg}}{L_r} - j(\omega_g - \omega_r)\bar{\psi}_{rg} \right] \cdot j\omega_g \frac{L_m}{L_r} \\ \frac{d\bar{u}'_{sg}}{dt} &= \omega_g \frac{L_m}{L_r} j\bar{u}_{rg} + R_r \frac{L_m^2}{L_r^2} \omega_g j\dot{i}_{sg} - (\omega_g - \omega_r) j\bar{u}'_{sg} - \frac{R_r}{L_r} \bar{u}'_{sg} \end{aligned} \quad (49)$$

Summarizing:

$$\bar{u}'_{sg} = -R_s j\dot{i}_{sg} + \omega_g \left(L_s - \frac{L_m^2}{L_r} \right) \dot{i}_{sg} + \bar{u}_{sg} \quad (50)$$

$$\frac{d\bar{u}'_{sg}}{dt} = \omega_g \frac{L_m}{L_r} j\bar{u}_{rg} + R_r \frac{L_m^2}{L_r^2} \omega_g j\dot{i}_{sg} - (\omega_g - \omega_r) j\bar{u}'_{sg} - \frac{R_r}{L_r} \bar{u}'_{sg} \quad (51)$$

Appendix B

$$P = \frac{3}{2} (u_{sy} i_{sy}) \quad Q = \frac{3}{2} (u_{sy} i_{sx}) \quad (52)$$

Taking \dot{i}_{sg} and \dot{i}_{rg} from (46) and (47), respectively and considering $u_{sy} = U$:

$$\dot{i}_{sg} = \frac{\bar{u}_{sg} - j\omega_g \bar{\psi}_{sg}}{R_s} \quad \text{and} \quad \bar{\psi}_{sg} = L_s \dot{i}_{sg} + L_m \dot{i}_{rg} \Rightarrow \dot{i}_{sg} = \frac{\bar{u}_{sg} - j\omega_g (L_s \dot{i}_{sg} + L_m \dot{i}_{rg})}{R_s},$$

$$\text{and} \quad \bar{\psi}_{rg} = L_r \dot{i}_{rg} + L_m \dot{i}_{sg} \Rightarrow \dot{i}_{rg} = \frac{-\frac{d\bar{\psi}_{rg}}{dt} - j(\omega_g - \omega_r)\bar{\psi}_{rg}}{R_r}.$$

Taking the last three expressions it is possible to get \dot{i}_{rg} as a function of \dot{i}_{sg} , \bar{u}_{sg} , $\frac{d\omega_g}{dt}$, ω_g , ω_r . Then, replacing \dot{i}_{rg} in the second expression and from the first one it

is possible to obtain i_{sg} as a function of $\frac{d\omega_g}{dt}$, $\frac{d\bar{u}_{sg}}{dt}$, \bar{u}_{sg} . Finally, active and reactive powers become:

$$P = \frac{U^2(R_s - L_m \omega_g(\omega_g - \omega_r)A)}{(R_s - L_m \omega_g(\omega_g - \omega_r)A)^2 + \left(\omega_g L_s + L_m A \frac{d\omega_g}{dt} + L_m(\omega_g - \omega_r)B\right)^2} - \frac{U \left(\omega_g L_s + L_m A \frac{d\omega_g}{dt} + L_m(\omega_g - \omega_r)B\right) \omega_g L_m \left(\frac{A}{R_s} \frac{dU}{dt} - \left(\frac{A}{R_s} \frac{d\omega_g}{dt} + (\omega_g - \omega_r) \frac{B}{R_s}\right) \frac{U}{\omega_g}\right)}{(R_s - L_m \omega_g(\omega_g - \omega_r)A)^2 + \left(\omega_g L_s + L_m A \frac{d\omega_g}{dt} + L_m(\omega_g - \omega_r)B\right)^2}$$

$$Q = \frac{U \omega_g L_m \left(\frac{A}{R_s} \frac{dU}{dt} - \left(\frac{A}{R_s} \frac{d\omega_g}{dt} + (\omega_g - \omega_r) \frac{B}{R_s}\right) \frac{U}{\omega_g}\right)}{(R_s - \omega_g L_m(\omega_g - \omega_r)A)} + \frac{U^2 \left(\omega_g L_s + L_m A \frac{d\omega_g}{dt} + L_m(\omega_g - \omega_r)B\right)}{(R_s - L_m \omega_g(\omega_g - \omega_r)A)^2 + \left(\omega_g L_s + L_m A \frac{d\omega_g}{dt} + L_m(\omega_g - \omega_r)B\right)^2} - \frac{U \left(\omega_g L_s + L_m A \frac{d\omega_g}{dt} + L_m(\omega_g - \omega_r)B\right)^2 \omega_g L_m \left(\frac{A}{R_s} \frac{dU}{dt} - \left(\frac{A}{R_s} \frac{d\omega_g}{dt} + (\omega_g - \omega_r) \frac{B}{R_s}\right) \frac{U}{\omega_g}\right)}{(R_s - \omega_g L_m(\omega_g - \omega_r)A) \left[(R_s - L_m \omega_g(\omega_g - \omega_r)A)^2 + \left(\omega_g L_s + L_m A \frac{d\omega_g}{dt} + L_m(\omega_g - \omega_r)B\right)^2 \right]}$$

Due to $R_s \approx 0$ when $P > HP$ [12] and considering low slip, some simplifications can be done:

$$P \cong - \frac{3UL_m \left(A \frac{dU}{dt} - A \frac{d\omega_g}{dt} \frac{U}{\omega_g} - (\omega_g - \omega_r) B \frac{U}{\omega_g} \right)}{2R_s L_s}$$

$$\cong \frac{3U^2 L_m (\omega_g - \omega_r) B}{2R_s L_s \omega_g} - \frac{3UL_m A}{2R_s L_s} \frac{dU}{dt} + \frac{3U^2 L_m A}{2R_s L_s \omega_g} \frac{d\omega_g}{dt}$$

$$P \cong K_{01} U^2 + K_{02} \frac{U^2}{\omega_g + \Delta\omega_g} + K_1 U \frac{dU}{dt} + K_2 \frac{U^2}{\omega_g + \Delta\omega_g} \frac{d\omega_g}{dt}$$

$$Q \cong - \frac{\frac{3}{2} U \left(\frac{A}{R_s} \frac{dU}{dt} - \left(\frac{A}{R_s} \frac{d\omega_g}{dt} + (\omega_g - \omega_r) \frac{B}{R_s} \right) \frac{U}{\omega_g} \right)}{(\omega_g - \omega_r) A} + \frac{\frac{3}{2} U^2}{\omega_g L_s + L_m A \frac{d\omega_g}{dt} + L_m (\omega_g - \omega_r) B} + \frac{\frac{3}{2} U \left(\frac{A}{R_s} \frac{dU}{dt} - \left(\frac{A}{R_s} \frac{d\omega_g}{dt} + (\omega_g - \omega_r) \frac{B}{R_s} \right) \frac{U}{\omega_g} \right)}{(\omega_g - \omega_r) A}$$

$$Q \cong \frac{\frac{3}{2}U^2}{\omega_g L_s + L_m A \frac{d\omega_g}{dt} + L_m (\omega_g - \omega_r) B} = \frac{\frac{3}{2}U^2}{(\omega_g + \Delta\omega_g)(L_s + L_m B) + L_m A \frac{d\omega_g}{dt} - L_m \omega_r B}$$

Acknowledgements

This work was supported by National University of Patagonia San Juan Bosco.

Author details

Roberto Daniel Fernández^{1*}, Pedro Eugenio Battaiotto² and Ricardo Julián Mantz³

*Address all correspondence to: dfernandez@unpata.edu.ar

1 National University of Patagonia San Juan Bosco, Argentina

2 National University of La Plata, Argentina

3 National University of La Plata and Scientific Investigation Commission of Buenos Aires State (CICpBA), Argentina

References

- [1] DeMeo E, Grant W, Schuerger N. Wind Plant Integration. Costs, Status, and Issues. IEEE Power & Energy Magazine. 2005 Nov-Dec; p. 38–46.
- [2] Machowski J, Bialek J, Bumby J. Power Systems Dynamics. Stability and Control. Wiley; 2008.
- [3] Ummels BC, Gibescu M, Pelgrum E, Kling WL, Brand AN. Impacts of Wind Power on Thermal Generation Unit Commitment and Dispatch. IEEE Transactions on Energy Conversion. 2007 March; 22(01):44–51.
- [4] Ortega-Vazquez MA, Kirschen DS. Estimating the Spinning Reserve Requirements in Systems With Significant Wind Power Generation Penetration. IEEE Transactions on Power Systems. 2009 Feb; 24 (01):144–124.
- [5] Kundur P. Power Systems Stability and Control. McGraw-Hill; 1993.
- [6] Sauer PW, Pai MA. Power Systems Dynamics and Stability. Prentice-Hall; 1998.

- [7] Slootweg JG, Kling WL. The impact of large scale wind power generation on power system oscillations. *Electric Power Systems Research*. 2003;67:9–20.
- [8] Fernández RD, Mantz RJ, Battaiotto PE. Potential contribution of wind farms to damp oscillations in weak grids with high wind penetration. *Renewable & Sustainable Energy Reviews*. 2007;doi:10.1016/j.rser.2007.01.013.
- [9] Fernández RD, Mantz RJ, Battaiotto PE. Impact of Wind Farms Voltage Regulation on the Stability of the Network Frequency. *International Journal of Hydrogen Energy*. 2008; 33(13): 3543–3548.
- [10] Fernández RD, Mantz RJ, Battaiotto PE. Wind farm non-linear control for damping electromechanical oscillations of power systems. *Renewable Energy* doi:10.1016/j.renene.2008.01.004. 2008 October;33(10):2258–2265.
- [11] Zavadil R, Miller N, Muljadi E. Making Connections. *IEEE Power and Energy Magazine*. 2005;p. 26–37.
- [12] Vas P. *Sensorless Vector and Direct Torque Control*. Oxford University Press; 1998.
- [13] Krause K, Wasynczuk O, Sudhoff S. *Analysis of Electric Machinery and Drives Systems*. Wiley-Interscience IEEE Press; 2002.
- [14] Ledesma P. *Parques Eólicos*. Doctoral Dissertation. Universidad Carlos III. Madrid. España; 2001.
- [15] Mohan N. *Advanced Electric Drives. Analysis, Control and Modeling using Simulink*. MNPERE; 2001.
- [16] Petersson A, Harnefors L, Thiringer T. Comparison between statorflux and grid-flux-oriented rotor current control of doubly-fed induction generators. In: 35th Annual IEEE Power Electronics Specialists Conference; 2004. p. 482–489. 22
- [17] Thiringer T, Petersson A, Petru T. Grid disturbance response of wind turbines equipped with induction generators and Doubly-fed induction generators. *IEEE Power Engineering Society General Meeting*, 2003; p. 1341–1655.
- [18] Xiao L, Lin L, Liu Y. Discussion on the architecture and operation mode of future power grids. *Energies*. 2011;(4):1025–1035.
- [19] Fernández RD, Mantz RJ, Battaiotto PE. Linear and non-linear control of wind farms. Contribution to the grid stability. *International Journal of Hydrogen Energy*, 2010, v. 35, n. 11, p. 6019-6024.
- [20] Hansen AD, Sørensen P, Iovb F, Blaabjerg F. Centralised Power Control of Wind Farm with Doubly Fed Induction Generators. *Renewable Energy*. 2006 June;31(7): 935–951.
- [21] Gandhari M. *Control Lyapunov Functions: A Control Strategy for Damping of Power Oscillations in Large Power Systems*. Doctoral Dissertation. Royal Institute of Technology. Stockholm. Sweden; 2000.

- [22] Freeman RA, Kokotovic PV. *Robust Nonlinear Control Design*. Birkhauser; 1996.
- [23] Noroozian M, Ghandhari M, Andersson G, Gronquist J, Hiskens I. A Robust Control Strategy for Shunt and Series Reactive Compensators to Damp Electromechanical Oscillations. *IEEE Transactions on Power Delivery*. 2001 Oct;16(4):812–817.
- [24] American Wind Energy Association AWEA. *Electrical Guide to Utility Scale Wind Turbines*; 2005. <http://www.awea.org>. March 27nd, 2007. AWEA Grid Code White Paper.
- [25] Ortega R, García Canseco E. Interconnection and Damping Assignment Passivity-Based Control: Towards a Constructive Procedure - Part I. 43rd IEEE Conference on Decision and Control. 2004; ThB07.1.
- [26] Ortega R, García Canseco E. Interconnection and Damping Assignment Passivity-Based Control: Towards a Constructive Procedure - Part II. 43rd IEEE Conference on Decision and Control. 2004; ThB07.2.
- [27] Ortega R, Loría A, Nicklasson PJ, Sira-Ramírez H. *Passivity-based Control of Euler-Lagrange Systems*. Springer-Verlag; 1998.
- [28] Galaz M, Ortega R, Bazanella AS, Stankovic AM. An energy-shaping approach to the design of excitation control of synchronous generators. *Automatica*. 2003; 39(1):111–119.
- [29] Ortega R, Galaz M, Astolfi A, Sun Y, Shen T. Transient Stabilization of Multimachine Power Systems with Nontrivial Transfer Conductances. *IEEE Transactions on Automatic Control*. 2005 Jan; 50(1):60–75.
- [30] Fernández RD, Mantz RJ, Battaiotto PE. Passivity based wind farm control for transient stabilization of an electrical network. In: *World Wind Energy Conference & Exhibition -WVEC 2007*; 2007.
- [31] Fernández RD, Mantz RJ, Battaiotto PE. Wind farm control for stabilisation of electrical networks based on passivity. *International Journal of Control*. 2010;83(1):105–114.

