

We are IntechOpen, the world's leading publisher of Open Access books Built by scientists, for scientists

4,800

Open access books available

122,000

International authors and editors

135M

Downloads

Our authors are among the

154

Countries delivered to

TOP 1%

most cited scientists

12.2%

Contributors from top 500 universities



WEB OF SCIENCE™

Selection of our books indexed in the Book Citation Index
in Web of Science™ Core Collection (BKCI)

Interested in publishing with us?
Contact book.department@intechopen.com

Numbers displayed above are based on latest data collected.

For more information visit www.intechopen.com



Special Considerations in Asian Knee Arthroplasty

Hamid Reza Seyyed Hosseinzadeh, Samih Tarabichi,
Ali Sina Shahi, Mehrnoush Hassas Yeganeh,
Usama Hassan Saleh, Gholam Reza Kazemian and
Aidin Masoudi

Additional information is available at the end of the chapter

<http://dx.doi.org/10.5772/53595>

1. Introduction

Human body is a unique correlation between anatomy and physiology. It is mandatory to have adequate knowledge on this issue former to perform any kind of surgery. As in all parts of human body, there are several variations in human knee concerning middle-eastern and Asian ethnicity, which should be considered for performing total knee arthroplasty among these races. These differences involve both in anatomical and physiological features, causing variations in a wide spectrum from metabolic syndromes to morphology of knee components.

During total knee replacement, the accurate bone cutting, adequate balancing of the soft tissues and proper coverage of the resected surface were important factors for achieving a successful outcome. In recent years, many studies have identified shape differences in the knee within the Caucasian population. Total knee replacement is a precise procedure, requiring accurate soft tissue balancing and resection of bone thickness equal to the thickness of the implanted prosthetic component. Proper bone cuts for rotational alignment of the femur and tibia in the axial plane represents the key for a balanced flexion gap and proper patella tracking. Both represent important parameters for high flexion. [1] A properly shaped prosthesis can provide the best coverage and avoid soft tissue impingement. Thus, it becomes important to obtain the anthropometric data to achieve the best stability and longevity for implant. Total knee prostheses based on the accurately morphologic data of knee, gender morphologic difference, and the morphologic correlations between tibia and femur may be expected to give better results.

Differences among males and females have been widely reported, with females having a smaller mediolateral to anteroposterior ratio and more narrow distal femurs and different proximal tibia geometry. [2, 3] However, ethnic differences have not received much focus given that most existing TKA implant designs are based on the Caucasian population. But, many studies have determined that the prostheses designed for Caucasian patients are not suitable for Asian patients. Anatomic differences have been identified between both sex and ethnicity, with Caucasian subjects having a higher tibial torsion angle and lower varus alignment than Japanese.

As mentioned above, accurate sizing and proper placement of prosthetic components plays a major role in the success and long term survival of total knee arthroplasty (TKA). The femoral component sizing is an important determinant for achieving a well-balanced flexion-extension gap in a TKA. Mediolateral sizing of the femoral component is necessary for proper patellofemoral tracking and uniform stress distribution over the resected distal femoral surface; this contributes to the long term stability of the prosthesis. [1] Most of the total knee prostheses currently available have been developed using measurements from Caucasians. Caucasian knees have been shown to be generally larger than Asian knees. [4] It follows that these discrepancies may give rise to implant size mismatch with the resected bony surface of Asian patients. Several studies have found that the femoral aspect ratio (mediolateral [fML]/anteroposterior [fAP]) of the prostheses used in Asia were not suitable for Asian patients. For instance, Ho et al reported that 3 of 5 TKA systems used in China tended to cause mediolateral overhang of the component across the width of the resected femurs of Chinese patients. The authors also found a larger femoral aspect ratio in small knees and a proportionally smaller ratio in large knees, but all the 5 sets of implant systems examined in the study showed little changes in the aspect ratio with AP length. [2]

Iorio et al showed that the Japanese patients had a significantly less postoperative range of motion than white patients. Furthermore, 4.1% Japanese patients required revision after primary posterior cruciate-retaining TKA within an average follow-up of 6.6 years, whereas only 2.6% of their American cohort needed revision within an average follow-up of 9 years. The authors suggested that the racial morphologic differences might be a factor causing the differences in outcome. [5]

Systematic differences have also been observed. ACL laxity among Japanese is higher than Caucasians. [4] It has also been proven that the ACL laxity is significantly different between Malaysians and Caucasians. [6] This could be the result of different life style. The systematic differences are explained further through the chapter.

Some rare complications accompanied by TKA are more common among the ethnicity, such as insufficiency fracture. This could be as a result of having greater rates of risk factors like: osteoporosis, overweight and gross varus deformity. Insufficiency fracture would be presented by no history of trauma, sudden onset pain, knee instability and deformity. The patient surprisingly is unable to walk. Unfortunately it is common to be misdiagnosed as MCL insufficiency.

That's why it is very important to have special consideration while performing total knee arthroplasty among Asian or middle-eastern ethnicity.

These findings on TKA mismatching have led some researchers to suggest that Asia Pacific people should have special designs of TKA prosthesis system.

2. Three-dimensional morphology of the knee reveals ethnic differences

In recent years, many studies have identified shape differences in the knee within the Caucasian population. [7, 8, 9] Shape analyses have identified sex differences in the femoral midshaft, distal femur, and patella. [10] Ethnic differences have not received much focus given that most existing TKA implant designs are based on the Caucasian population. Many studies have reported the anatomy and comparison of East Asian populations (Japanese, Chinese, Indian) to existing implant systems. Mahfouz et al in a comprehensive, 3D analysis of the knee morphology identified shape differences in the distal femur and proximal tibia among the ethnic groups. [11]

They found AMs (East Asian Male) had a smaller ML/AP (mediolateral/anteroposterior) ratio than CMs (Caucasian Male) (1.33 ± 0.12 versus 1.4 ± 0.06), contrary to Yue et al. The mean and SD values of the ML for CMs (79 ± 4.6 mm) and CFs (Caucasian Female) (68.6 ± 4.8 mm) were comparable to those published by Yue et al. The normalized ratios and nonlinear shape analysis in this research supported differences between East Asians and Caucasians independent of any scale factor. They also found differences in the ratio between AAF/CF (African American Female/Caucasian Female) and AAM/CM (African American Male/Caucasian Male), with the mean ratio being larger in CMs compared to AAMs and CFs compared to AAFs. [11, 12, 13]

This finding conflicts with Gillespie et al. who reported a larger ML/AP ratio in African Americans than in Caucasians; however, their African American population was from the early 20th century, which could account for differing anatomic features from the current population. [3, 13] The radii of curvature analysis on both the medial and lateral condyles revealed AMs and AFs (American Female) tend to have more curved condyles (ie, smaller radius of curvature) than Caucasians, implying a larger ROM. This finding agrees with Leszko et al. who found an increased ROM of 153° for AF and 151° for AM compared to 146° for CM. [14] Women from all ethnic groups had smaller, narrower knees with a smaller ML/AP ratio.

This study by Mahfouz et al. shows that AAMs and AAFs have larger AP dimensions than their Asian and Caucasian counterparts and AMs and AFs have smaller AP dimensions than CMs and CFs. When compared to CFs with similar AP dimensions, AMs have larger ML dimensions. In analyzing ethnic differences in tibial anatomy, AAMs have larger LAPs (lateral anteroposterior diameter) and smaller MAPs (medial anteroposterior diameter) (Figure 1-B) than CMs, while also having larger ML and AP dimensions than AMs. AMs and AFs have smaller ML and AP dimensions than CMs and CFs. This study also identifies shape differen-

ces in the distal femur and proximal tibia between sexes in each ethnic population. Males across all ethnicities have average 9-mm larger ML and 5-mm larger AP dimensions than their female counterparts. AAMs and CFs have shallower patellar grooves than AAFs and CMs. Females have more curved femurs in all ethnicities. Males have larger tibial AP dimensions than females. AAMs and CMs have larger ML dimensions than AAFs and CFs, respectively. Differences in femoral and tibial shapes are also identified in comparing shapes across populations based on differences in ML/AP, AML/PML (anterior mediolateral length/posterior mediolateral length), and MAP/LAP ratios. [11] (Figure 1-A)

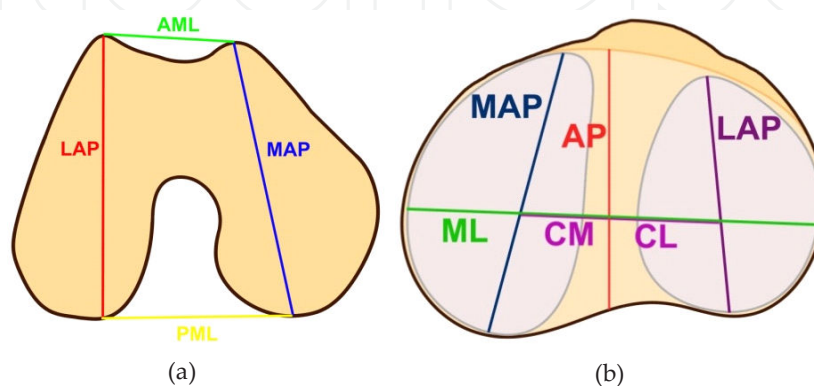

Figure 1. A) Diagram illustrating measurements on the distal femur. AML = Anterior mediolateral length, PML = Posterior mediolateral length, LAP = Lateral anteroposterior diameter, MAP = Medial anteroposterior diameter. B) Diagram illustrating measurements on the proximal tibia. ML = Mediolateral width, AP = Anteroposterior length, MAP = Medial anteroposterior length, LAP = Lateral anteroposterior length.

3. Normal development of the knee angle

Development of the knee angle from bowlegs (varus) in the infant to knock knees (valgus) in early childhood is a part of normal and physiological development. Several researchers have studied knee angle variation in various parts of the world and many of them have tried to set standards for certain ethnic/social groups. [15, 16, 17]

The TFA has been described as the angle defined by the mechanical axis of the femur intersecting the mechanical axis of the tibia.

There are studies available regarding normal development of the knee angle in whites, Chinese, Nigerians, Koreans, and Turkish children. Saini UC et al. have found that none of the subjects had a varus knee alignment in the more than 3 years age groups. Also, even for the children in the 2 years age group, the mean TFA was positive, indicating a mean valgus alignment in Indian children, even at the age of 2 years. [18] This was contrary to the findings of the largest study carried to date by Cheng et al. in the Chinese population, which showed a mean varus TFA at the age of 2 years. After 3 years, the authors noted a rapid decrease in the mean IMD in the Chinese children, reaching 0 cm at the age of 8 years, with a normal range of ± 3 cm. [19] In Turkish children, Arazi et al noted a significantly higher

degree of valgus angle than that in previous reports. The maximal mean valgus angle was 9.6° at 7 years of age for boys and 9.8° at 6 years of age for girls. These differences were considered to be racial differences between Turkish children and those of other races. Turkish children aged between 3 and 17 years were found to exhibit up to 11° physiologic valgus. The authors concluded that a measurable varus angle or a valgus higher than 11° during this period should be considered as abnormal. [20] In a study conducted by Heath and Staheli in white children, using clinical measurements of the TFA and the ICD and IMD, children were maximally bow-legged at the age of 6 months and progressed toward approximately neutral knee angles (0.0°) by the age of 18 months. They found the greatest mean knock knee of 8° at the age of 4 years, which was followed by a gradual decrease to a mean of 6° at 11 years of age. Normal children aged 2–11 years had knock knee up to 12° and IMD up to 8 cm. The existence of bowlegs after the age of 2 years was found to be abnormal. [21] Yoo et al. carried out a study on normal healthy Korean children, with full-length anteroposterior view standing radiographs. They found that the overall patterns of the chronological changes in the knee angle were similar to those described previously in western or Asian children, but the knee angle development was delayed, i.e., genu varum before 1 year, neutral at 1.5 years, increasing genu valgum with a maximum value of 7.8° at 4 years, followed by a gradual decrease to approximately $5\text{--}6^\circ$ of genu valgum of the adult level at 7–8 years of age. Although the use of different techniques to estimate the knee angles might be responsible for variations in observations in different studies, it is more likely that these variations are possibly due to the ethnical and racial differences that might exist in different population groups. [22] Arazi et al found the weight of children at a specific age to have a negative correlation with the ICD of the subject. However, this correlation was found to be weak and although statistically significant, it might not be of any clinical significance. The only possible explanation to this might be the relatively thick thighs of the heavier children, which is expected to subjectively decrease the ICD. However, considering the fact that fixed body landmarks on the body should not change even in obese children, this result is hard to explain. [20]

Oginni et al. who measured the knee angles of 2,036 normal Nigerian children up to an age of 12 years. In their study, they found the majority of the knees to be bowed (varus) in the first 6 months. At 21–23 months of age, the distribution of angles became strongly bimodal: about half being varus and half being valgus (knock-kneed). After this, the knee angle was found to be valgus in most of the children. They concluded that the change from varus to valgus in individual infants might be sudden (a few weeks), although the changeover of the whole population appeared smooth and gradual. The authors also concluded that varus knee alignment was uncommon after 2 years in Nigerian children and large knee angles between 2 and 5 years suggested rickets. However, in their study, the children became maximally and uniformly knock-kneed ($-7.1^\circ \pm 1.4^\circ$) between 3 and 3.5 years, with little change thereafter. [23] This is contrary to the findings in Indian children, in whom the maximum valgus has been found to occur at an age of 5–6 years. [18] As the literature shows, there is a wide variation in the normal development of the knee angle, which might be physiological.

3.1. Development of tibiofemoral angle in Indian children

Saini et al. observed the highest mean IMD of 4.5 cm in children aged 5 years, with a minimum mean of 1 cm at the age of 9 years. They also found that the maximum mean valgus was seen at the age of 6 years in Indian children. Thereafter, the valgus alignment decreased in Indian children and the mean TFA stabilized to lie between 4 and 5° in most of the children after the age of 10 years. Indian girls overall showed more valgus at the knees than boys and the results were statistically significant, especially at the age of 6 years, when peak valgus was achieved in Indian children. The maximum TFA of 11° was seen in a 6-year-old perfectly healthy girl. They also found a boy with a valgus knee angle of 10.5° at the age of 5 years. [18]

In India, there are statistically significant differences between the mean TFA of boys and girls in the age groups of 3, 5, and 6 years (Table 2). The mean TFA is significantly higher in Indian girls of age groups 3 and 6 years, while Indian boys of age group 5 years showed a significantly higher mean TFA. After the age of 6 years, there are no statistically significant differences between the mean TFA of Indian boys and girls.

Neither height nor body mass of a child at a specific age group have statistically significant correlation with the mean TFA or the ICD or IMD. [18]

Age in years	Mean TFA of males (\pm SD)	Mean TFA of females (\pm SD)
2	1.0 \pm 3.1	1.0 \pm 3.6
3	1.6 \pm 3.6	3.4 \pm 1.5
4	3.9 \pm 1.4	4.8 \pm 1.3
5	7.5 \pm 2.2	5.9 \pm 1.8
6	7.2 \pm 2.6	9.0 \pm 1.9
7	5.8 \pm 1.5	6.4 \pm 2.0
8	5.7 \pm 2.5	6.7 \pm 1.8
9	5.3 \pm 2.2	5.9 \pm 1.0
10	5.3 \pm 2.3	5.6 \pm 1.9
11	4.58 \pm 2.35	5.30 \pm 2.49
12	4.70 \pm 2.15	5.16 \pm 0.98
13	4.68 \pm 1.95	5.10 \pm 0.87
14	4.56 \pm 1.45	5.00 \pm 0.63
15	4.55 \pm 2.13	5.00 \pm 0.81
Total	4.61 \pm 2.96	5.39 \pm 2.45

Table 1. Mean TFA \pm SD distribution amongst male and female children at different ages

3.2. Development of tibiofemoral angle in Korean children

Yoo JH et al found that in Korean children, knee alignment or aTFA was in varus alignment in infancy, and became neutral at an average age of 1.5 yr. Development into valgus alignment continued until age 4 yr when it peaked at 7.8°. It then decreased slowly to plateau at 5-6° at age 7 to 8 yr, and remained at this level thereafter. This pattern of knee alignment change is similar to that found previously in other ethnic groups, except that the valgus peak occurred later. [22]

3.3. Axial alignment of the lower extremity in Chinese adults

Achieving normal axial alignment of the lower extremity is important to surgeons who perform reconstructive surgery of the knee. The normal alignment of the lower extremity in Caucasians has been documented by Moreland et al. with use of radiographs of the lower extremity. [24]

Tang WM et al. showed that the extremities of the Chinese women had a mean of 2.2 ± 2.5 degrees of varus alignment, and those of the Chinese men had a mean of 2.2 ± 2.7 degrees of varus alignment. The knees of Chinese female subjects, therefore, were in more varus alignment than were those in the white female subjects in the study by Hsu et al. [17, 25]

The inferolateral angle (Angle A in figure 2) between the knee joint surface and the mechanical axis of the tibia is an index of knee joint obliquity. If this angle is 90 degrees, the knee-joint surface is perpendicular to the mechanical axis. The knee-joint surface is inclined toward the medial side if this angle is larger than 90 degrees. This angle was a mean (and standard deviation) of 95.4 ± 2.5 degrees (range, 89.0 to 100.0 degrees) in the women and 94.9 ± 2.3 degrees (range, 90.5 to 102.0 degrees) in the men in this study. The mean medial inclination (Angle B in figure 2) of the knee joint surfaces in Chinese female and male subjects therefore was 5.4 ± 2.5 degrees and 4.9 ± 2.3 degrees, respectively, which is significantly more oblique than the commonly reported 3 degrees. The inferolateral angle in both the right and the left extremity in Chinese male subjects was significantly larger than that in the white subjects in the study by Moreland et al. In the study by Hsu et al., this angle was a mean of 91.0 ± 1.4 degrees in thirty white men (sixty lower extremities) who ranged in age from twenty-five to forty years and a mean of 90.1 ± 1.9 degrees in thirty white women who ranged in age from twenty-five to forty years. [24, 25]

As noted by Insall, one should be cautious in describing what is "normal" because of the substantial individual variations. Currently, designers of most total knee arthroplasty systems recommend placement of the components in such a way that the transverse axis of the artificial knee joint is perpendicular to the mechanical axes of the tibia and the femur. The resulting alignment of the lower extremity, therefore, is in close proximity to the alignment documented by Moreland et al. and Hsu et al. The mechanical axes of the femur and the tibia did not form a straight line in either Chinese males or females. This finding is in contrast to the general consensus that has been described previously. The Chinese females had more varus alignment of the knee than did the white female subjects in the study by Hsu et al. The authors did not find the same difference between the Chinese male subjects and the

white male subjects described by Moreland et al. and Hsu et al. Insall and Hungerford et al. described a 3-degree varus alignment of the knee-joint surface with reference to the mechanical axis of the tibia. Although Moreland et al. confirmed this 3-degree varus in white men, the finding was not reproduced in the study by Hsu et al. In this study of Chinese subjects, the surface of the knee joint had a medial inclination with respect to the tibia that was a mean of 5.4 degrees in the women and 4.9 degrees in the men. The values were found to be significantly different from those of the white subjects in the studies of Moreland et al. and Hsu et al. Therefore, if the tibial cut in a total knee arthroplasty is placed perpendicular to the mechanical axis of the tibia, 5 degrees of external rotation of the femoral component instead of the commonly reported 3 degrees might be necessary to produce a rectangular flexion gap in Chinese patients. [24, 25]

Fang et al. showed that femora in Chinese individuals are more bowed. In such patients, a short intramedullary rod entering the femur at the apex of the inter-condylar notch (femoral anatomical axis I) with a 4-degree distal cutting block is more likely to produce a distal femoral cut that is perpendicular to the mechanical axis of the femur. However, the choice of the cutting block should be individualized according to the preoperative planning on weight-bearing radiographs of the whole lower extremity. It is also interesting to note that the designers of some instrumentation systems have recommended use of a distal femoral cutting block with a smaller angle in taller individuals on the basis of the assumption that taller patients have a smaller physiological valgus angle of the femur. [26]

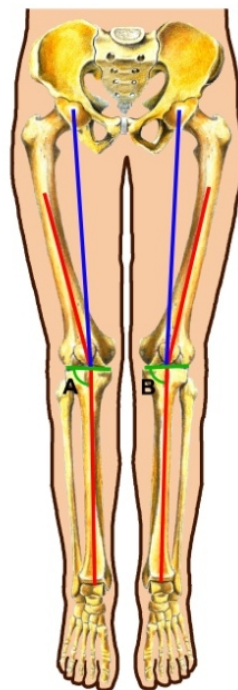

Figure 2. Diagram showing the anatomic (red) and mechanical (green) axes of the lower limb and the angles between them.

3.4. Axial alignment of the lower extremity in healthy Indian adults

Mullaji et al showed that the mean HKTA angle in healthy Indian adults was $1.3^\circ \pm 0.8^\circ$ of varus, mean distal femoral axis-femoral mechanical axis angle was $5.5^\circ \pm 0.8^\circ$, mean femoral condylar mechanical axis angle was $93.1^\circ \pm 1.6^\circ$, and mean femoral bow was $0.4^\circ \pm 1.2^\circ$. [27]

3.5. Variances in sagittal femoral shaft bowing

Tang WM et al have confirmed in Chinese patients distal sagittal bowing is a constant and important feature, and it affects the positioning of the femoral component on the sagittal plane. There is a dilemma of implanting the femoral component either according to the anatomy of the distal femur ignoring the bowing, or according the longitudinal axis of the femur on the sagittal plane. On one hand, following the distal anatomy might sufficiently flex the femoral component that it results in an undesirable impingement of the anterior aspect of the polyethylene post on knee extension if posterior-stabilized implants are used and thus become a source of osteolysis-inducing polyethylene particles. However, following the longitudinal axis of the femur might result in an extended femoral component that could compromise the anterior cortex of the distal femur. In Chinese patients who have undergone TKA, distal sagittal bowing of the femur is common but the common pattern is posteromedial osteoarthritis. This apparent inconsistency could be the result of differences in tibial slope and the joint line obliquity in Chinese patients. [28]

4. Three dimensional morphometry of the Chinese knees

4.1. Proximal tibial morphology

The average tibial mediolateral (tML) and tibial anteroposterior (tAP) measurement for Chinese knees are 73.0 ± 4.6 mm and 48.8 ± 3.4 mm, respectively. Males have larger values for tML and tAP compared with females. The male subject have larger values than female subject in the mediolateral dimension under a given anteroposterior dimension. [29] To evaluate possible differences between the medial and lateral plateau, Bo Cheng et al measured the tMAP and tLAP, and found that the tMAP was larger than the tLAP by an average of 5.6 ± 3.2 mm in males and 5.1 ± 2.2 in females, the CL had larger values than CM (Figure 1, B) by an average of 4.9 ± 2.2 mm in males and 4.3 ± 1.7 mm in females. They also calculated the aspect ratio of the tibia (tML/tAP%). The average aspect ratio of the tibia was 149.7 ± 5.2 . (Table 2) The aspect ratio showed a definitely negative correlation with tAP. From the relationship between the aspect ratio (tML/tAP %) and tAP, the authors found that there were large values in the aspect ratio with the smaller tAP, and that males have larger values in the aspect ratio than females having the same values for anteroposterior dimension. Compared with the five tibial components, only one of the prostheses had a declining change in the aspect ratio parallel with the increasing tAP. Even so, but the rate of change did not match that of the Chinese population. [29]

4.2. Distal femoral morphology

The femoral mediolateral (fML) and femoral anteroposterior (fAP) measurements are 71.0 ± 3.0 mm and 64.1 ± 2.7 mm, respectively. The male have larger values in fML and fAP compared with female. Comparing the morphological data with similar values for five conventional femoral components currently used in China, Bo Cheng et al found that two of the prostheses had large values in fML dimension with all range of the fAP. This was more evident with reference to female. They found that males have larger values in mediolateral dimension than females under the same value in the anteroposterior dimension. They also found that the fMAP had larger values than fLAP by an average of 0.8 ± 0.3 mm in males and 0.5 ± 0.2 mm in females. The average aspect ratio was 111.1 ± 2.7 (Table 3) and had a negative correlation with the fAP. The femoral aspect ratio was higher for smaller knees and proportionally lower for larger knees. Female subjects had a smaller aspect ratio with the same anteroposterior dimension. Only one of the five femoral components showed a similar negative correlation with the fAP. Even so, the rate of change was not the same as that of the Chinese population. [29]

4.2.1. Morphologic relationships between the tibia and femur

Bo Cheng et al also analyzed the correlation between the tibial mediolateral (tML) and femoral mediolateral (fML) dimension, and between the tibial mediolateral (tML) and femoral anteroposterior (fAP) measurement. The results showed that the fML and fAP were strongly correlated with the tML. As the tML increasing, the fML and fAP also increased. [29]

Parameters	Male	Female	Combined
Tibial mediolateral (tML)	76.4 ± 2.8	68.8 ± 4.6	73.0 ± 4.6
Tibial middle anteroposterior (tAP)	51.3 ± 2.0	45.7 ± 1.9	48.8 ± 3.4
Tibial medial anteroposterior (tMAP)	53.3 ± 2.5	47.5 ± 2.4	50.7 ± 2.4
Tibial lateral anteroposterior (tLAP)	47.7 ± 2.7	42.4 ± 2.3	45.3 ± 2.5
Medial to central distance (CM)	13.2 ± 2.6	11.9 ± 2.0	12.7 ± 2.1
Lateral to central distance (CL)	18.1 ± 2.4	16.2 ± 2.3	17.3 ± 2.3
Aspect ratio (tML/tAP)	149.0 ± 5.7	150.7 ± 6.1	149.7 ± 5.2
tMAP-tLAP	5.6 ± 3.2	5.1 ± 2.2	5.4 ± 2.8

Table 2. Average values of the tibia morphology measurement (mm).

Parameters	Male	Female	Combined
Femoral anteroposterior (fAP)	66.6±2.4	61.0±2.7	64.1±2.7
Femoral mediolateral (fML)	74.4±2.9	66.8±3.1	71.0±3.0
Femoral medial anteroposterior (fMAP)	52.6±2.4	49.8±3.2	51.3±3.3
Femoral lateral anteroposterior (fLAP)	51.8±3.7	49.3±4.1	50.7±4.0
Aspect ratio (fML/fAP %)	111.7±3.3	109.6±3.6	111.1±2.7
fMAP-fLAP	0.8±0.3	0.5±0.2	0.6±0.3

Table 3. Average values of the femur morphology measurement (mm).

4.2.2. Utility

Quantification of the tML and tAP revealed that the female has a smaller tibial surface than the male, and both have smaller values than the Caucasian population. In the tibia of the Chinese population, the morphologic data showed a decreasing aspect ratio (tML/tAP %) as the tAP dimension increased, which is similar in many studies. In contrast, a majority of the implants had a relatively constant aspect ratio. Comparing five major conventional prostheses, it is evident that tML is undersized with the smaller tAP, and overhang with the larger tAP. This is more evident in male knee. In the morphology of the femur, females have a smaller aspect ratio with the same femoral anteroposterior dimension, which suggest that women have generally narrower femora than men when the femoral anteroposterior dimension is adequate. These results suggest that the prostheses which are suitable for Caucasian patients may be larger than ideal for Chinese patients. Bo Cheng et al also found that the femoral condyles in the Chinese population are asymmetric. These results may imply that asymmetric femoral component could prevent soft tissue irritation.

Since the tML is strongly correlated with the fML and fAP, it is important to consider the tibia and femur as a whole. Therefore, the tML and fAP should be considered as the criteria to design gender-specific proper prostheses suitable for most of Chinese population.

4.3. Distal rotational alignment of the chinese femur

Yip et al showed a statistically significant difference in Whiteside-epicondylar angle when using the mechanical (2.3°) compared with the anatomic (1.1°) axes in Chinese population. The posterior condylar angle in this study was shown to be 5.1° (for men) and 5.8° (for women). [30] (Figure 3)

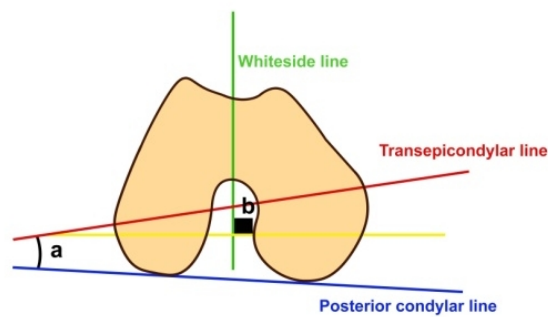

Figure 3. The whiteside-epicondylar (a) and Posterior condylar (b) angles.

4.3.1. The offset of the tibial shaft from the tibial plateau in Chinese people

Tang et al conducted a study to identify the location of the tibial shaft axis on the tibial plateau with the use of magnetic resonance imaging scans in a Chinese population. All of the measurements were made at three resection levels. The first resection level was just distal to the subchondral bone of the medial tibial plateau, which represented the clinical situation of the level of a bone cut in a proximal tibial segment with mild bone loss. The second resection level was 5mm distal to the subchondral bone of the medial tibial plateau, which represented the level of a bone cut in a proximal tibial segment with moderate bone loss. The third resection level was 10 mm distal to the subchondral bone of the medial tibial plateau, which represented the level of a bone cut in a proximal tibial segment with severe bone loss. They showed that the mean offset (and standard deviation) of the tibial shaft from the tibial plateau was 7.23 ± 2.44 mm (range, 1.62 to 12.26 mm), 6.33 ± 2.26 mm (range, 1.31 to 11.36 mm), and 4.75 ± 2.07 mm (range, 0.46 to 9.36 mm) at the first, second, and third resection levels, respectively. In almost all the knees that were examined, the tibial shaft axis was located anterolateral to the center of the tibial plateau at all resection levels. The anteroposterior and mediolateral offsets and the anteroposterior and mediolateral dimensions of the tibial plateau in the male group were significantly larger than those in the female group at each resection level. [31]

4.3.2. Utility

Several studies have revealed that the axis of the tibial shaft is, on the average, located anteromedial to the center of the tibial plateau in the Western population, for whom a medially offset stem seems more suitable. [32-34]

But, these results confirm that the axis of the tibial shaft does not overlap the center of the tibial plateau in Chinese people. Abraham et al. performed total knee arthroplasty in twenty cadaver tibiae and found that the average distance between the center of the tibial diaphysis and the center of the tibial metaphysis was 4.1 mm at the resection level of the fibular head. In view of the findings of Abraham et al. [35] as well as this study, it would appear that an offset stem would be more suitable for Chinese patients who need a long-stemmed tibial component. These authors also noted that there was a large variation in the offset of the tibi-

al shaft from the tibial plateau, ranging from 0.46 to 12.26 mm, so it would be desirable to have a wide range of offset stems available—for example, from 0 to 16 mm, in 2-mm or 4-mm increments. [35]

In a study on Iranian normal adult knees, we assessed the tibial plateau shift angle (TPSA) in order to assess our hypothesis that the proximal tibia of Iranian knee is not the same as the western knees. Our TPSA findings demonstrate that tibial plateau was not symmetrical and the Cp passes medial to Cs. This shows that the tibial plateaus in Iranian knees have a medial offset in regard to tibial shaft. So we consider that the center of the tibial plateau should not be used as a landmark of the tibial component.

Yoo et al. studied the placement of the tibial stem in close relation to the medial tibial cortex when using total knee replacements (TKRs) with medially-offset tibial stems in Korean patients. They found that the midline of the tibial stem was located medial to the tibial shaft axis in 79.7% of knees. In 6.5% of knees there was radiological contact between the tibial stem or cement mantle and the medial tibial cortex. This study has shown that the medially-offset stem in the tibial component may not be a good option for knees undergoing replacement Korean patients. (Figure 4) These researches show that some tibial base-plates specifically designed for Caucasians may not be suitable for Asian people and it remains a necessity to design a special tibial base-plate for these ethnic groups. [36] (Figure 5)

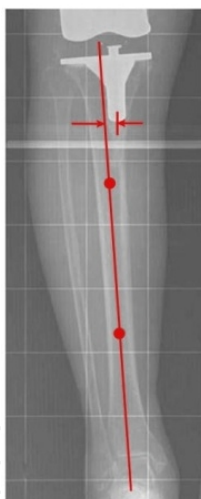

Figure 4. Anteroposterior postoperative radiograph showing the distance between the tip of the stem and the tibial shaft axis (between arrows)

4.4. Posterior slope of tibial plateau in Chinese

Kapandji found that the tibial plateau was inclined posteriorly for 5° to 6° with the horizontal and called this *retroversion* in the sagittal plane of the tibia. Insall and Kelly quoted that the posterior slope was approximately 10° with respect to the shaft of the tibia in western population. [38] Chiu et al. studied the posterior tibial slope in Chinese population. On visual inspection, they found that the posterior slope of the medial tibial plateau was 14.8°

(SD, 4.2°; range, 5°-25°), and that of the lateral tibial plateau was 11.8 ° (SD, 3.8°; range, 4°-23°). The association between the posterior slopes of the medial and lateral tibial plateau was not strong.

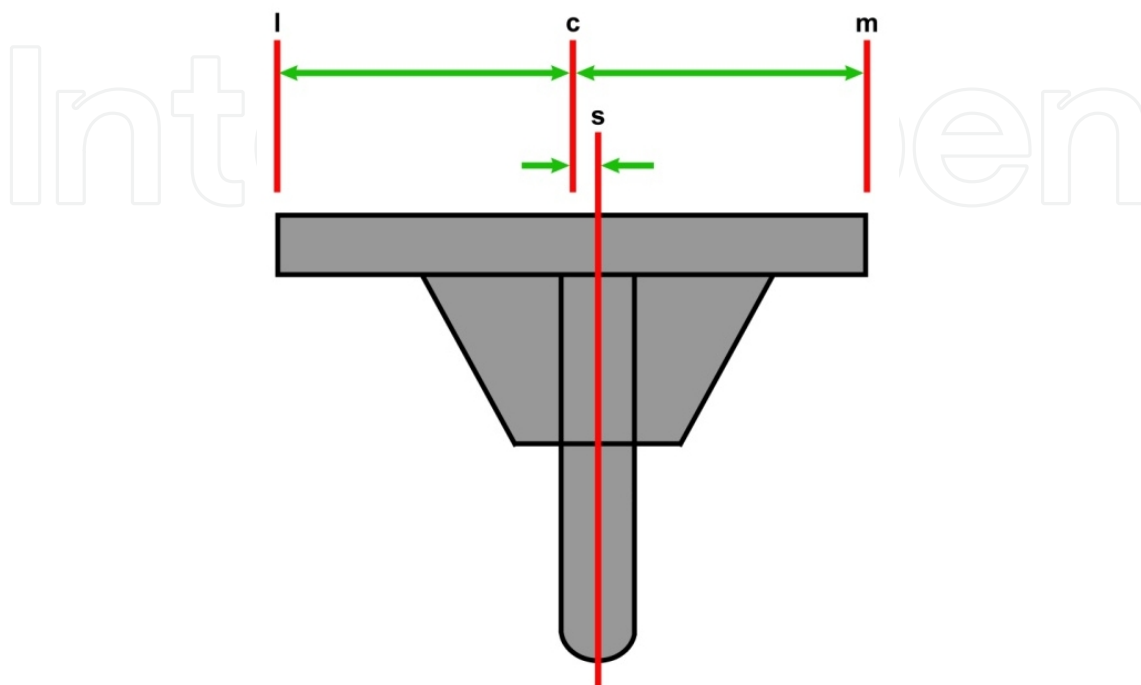

Figure 5. Diagram showing a right tibial component with a medially-offset stem. The tip of the stem (s) is located medial to the center of the tibial tray (c) which is equidistant from the medial (m) and lateral (l) borders of the tibial component. The distance between c and s corresponds to the amount of medial offset.

The difference between the posterior slopes of the medial and lateral tibial plateau was statistically significant. On radiographic assessment, they showed that the posterior slope was 14.7 ° (SD, 3.7°; range, 5°-22 °) with the extramedullary alignment line and 11.5 ° (SD, 3.6°; range, 2°-18.5 °) with the intramedullary alignment line. The association between the posterior slopes with the 2 alignment lines was strong. The difference between the posterior slopes with the 2 alignment lines was statistically significant. The posterior slope of the medial tibial plateau on visual inspection showed stronger correlation to the posterior slopes determined by radiographs. The posterior slope of the lateral tibial plateau on visual inspection had weaker correlation to the posterior slopes with the intramedullary alignment line and extramedullary alignment line in the radiographs. [38]

4.5. Ethnic differences of knee anthropometry

4.5.1. Between Chinese and white men and women

Recent anthropometric studies have suggested that current design of total knee arthroplasty (TKA) does not cater to racial anthropometric differences. Most of the commercially availa-

ble TKA prostheses are designed according to the anthropometric data of white knees, which has been suspected as the cause of the component mismatch in Asian people. Several studies have compared the morphology of Asian knees to that of TKA prostheses currently used in Asia and found that the femoral aspect ratio (mediolateral [fML]/anteroposterior [fAP]) of these prostheses were not suitable for Asian patients. Iorio et al showed that the Japanese patients had a significantly less postoperative range of motion than white patients. Furthermore, 4.1% Japanese patients required revision after primary posterior cruciate-retaining TKA within an average follow-up of 6.6 years, whereas only 2.6% of their American cohort needed revision within an average follow-up of 9 years. The authors suggested that the racial morphologic differences might be a factor causing the differences in outcome. [5]

Yue B et al showed that the fML dimension of Chinese females (72.8 ± 2.6 mm; range, 70.0-79.1 mm) was significantly smaller than that of white females (76.4 ± 4.0 mm; range, 70.3-82 mm) ($P = .002$). The fAP dimension was 58.8 ± 2.5 mm (range, 53.2-63 mm) for Chinese females and 59.7 ± 2.6 mm (range, 54.6-64.1 mm) for white females. The difference in fAP dimension was not statistically significant. A statistically significant difference was noted between the fML/fAP ratios of Chinese females (1.24 ± 0.04 ; range, 1.17-1.32) and white females (1.28 ± 0.06 ; range, 1.16-1.39). The morphological data showed a progressive decline in the fML/fAP ratio with increasing fAP dimension for both races. However, there was a distinct offset between the fML/fAP ratio of Chinese and white females, indicating that the Chinese females had a smaller fML/fAP ratio than white females for the same fAP dimension. (Table 5) Measurements of tibia showed that the tibial size of Chinese females was generally smaller than that of white females. However, the tibial aspect ratio did not show any significant difference between Chinese (1.78 ± 0.1 ; range, 1.56-1.96) and white females (1.76 ± 0.08 ; range, 1.58-1.89). The medial/lateral posterior tibial slopes showed no difference between the 2 groups. The average medial slope was $5.4^\circ \pm 2.3^\circ$ (range, 1.4° - 10.1°) for Chinese females and $6.5^\circ \pm 2.9^\circ$ (range, 0.6° - 10.7°) for white females. The average lateral slope was $4.8^\circ \pm 2.8^\circ$ (range, 0.3° - 10.6°) for Chinese females and $5.8^\circ \pm 2.7^\circ$ (range, 0.8° - 10.4°) for white females. Chinese males had an average fML dimension of 82.6 ± 3.6 mm (range, 72.6-87.1 mm), which was significantly smaller than that of white males (86.0 ± 5.6 mm; range, 74.9-100.2 mm). The fAP size averaged 65.0 ± 2.8 mm (range, 59.4-70.3 mm) for Chinese males and 67.5 ± 3.6 mm (range, 62.4-75.3 mm) for white males. The difference was statistically significant between fAP size of Chinese and white males. The femoral aspect ratio (fML/fAP) of Chinese males averaged 1.27 ± 0.03 (range, 1.22-1.33) and white males 1.28 ± 0.07 (range, 1.12-1.37), and there was no statistically significant difference. The tibial dimension of Chinese males was generally smaller than that of white males. A significant difference was noted for the tibial aspect ratio, with Chinese males averaging 1.82 ± 0.07 (range, 1.70-1.95) and white males averaging 1.75 ± 0.11 (range, 1.58-1.87). The morphological data showed a progressive decline in the tibial aspect ratio with increasing average tAP dimension for both races. The lines representing change in tibial aspect ratio with increasing average tAP dimension for Chinese and white males were nearly coincident. Therefore, the differences in tibial aspect ratios between the 2 groups may be caused by the average tAP dimensions of Chinese males that were generally smaller than those of white males. The medial/lateral plateau posterior slope showed no significant difference between the 2 groups.

The average medial slope was $6.0^\circ \pm 2.5^\circ$ (range, 2.7° - 12.0°) for Chinese males and $5.1^\circ \pm 3.3^\circ$ (range, -3.0° to 11.1°) for white males. The average lateral slope was $5.2^\circ \pm 3.6^\circ$ (range, -1.8° to 14.0°) for Chinese males and $5.6^\circ \pm 2.7^\circ$ (range, 2.5° - 15.1°) for white males. [39] (Table 5)

	fML (mm)	fAP (mm)	fML/fAP
Chinese female	72.8 ± 2.6 (70.0-79.1)	58.8 ± 2.5 (53.2-63)	1.24 ± 0.04 (1.17-1.32)
White female	76.4 ± 4.0 (70.3-82)	59.7 ± 2.6 (54.6-64.1)	1.28 ± 0.06 (1.16-1.39)
Chinese male	82.6 ± 3.6 (72.6-87.1)	65.0 ± 2.8 (59.4-70.3)	1.27 ± 0.03 (1.22-1.33)
White male	86.0 ± 5.6 (74.9-100.2)	67.5 ± 3.6 (62.4-75.3)	1.28 ± 0.07 (1.12-1.37)

Table 4. Femoral Measurements Categorized by Race and Sex.

	Tibial Plateau Dimensions					Posterior Tibial Slope (deg)		
	MPAP (mm)	LPAP (mm)	Average AP (mm)	tML (mm)	tML/Avg. tAP	MPPS	LPPS	Average Posterior Slope
Chinese female	41.5 ± 3.0 (37.6-48.6)	33.2 ± 3.2 (28.7-40.2)	37.3 ± 2.8 (34.5-44.1)	66.2 ± 2.1 (63.1-69.5)	1.78 ± 0.10 (1.56-1.96)	5.4 ± 2.3 (1.4-10.1)	4.8 ± 2.8 (0.3-10.6)	5.1 ± 2.3 (1.4-9.9)
White female	43.4 ± 1.9 (39.2-46.5)	35.2 ± 3.8 (26.5-40.0)	39.3 ± 2.6 (34.1-43.3)	69.0 ± 4.2 (61.3-74.4)	1.76 ± 0.08 (1.58-1.89)	6.5 ± 2.9 (0.6-10.7)	5.8 ± 2.7 (0.8-10.4)	6.1 ± 2.5 (0.7-9.8)
Chinese male	46.1 ± 2.4 (42.0-49.5)	36.8 ± 2.1 (34.1-40.7)	41.5 ± 2.1 (38.0-45.1)	75.2 ± 3.6 (67.6-81.5)	1.82 ± 0.07 (1.70-1.95)	6.0 ± 2.5 (2.7-12.0)	5.2 ± 3.6 (-1.8-14.0)	5.6 ± 2.8 (0.4-11.9)
White male	49.3 ± 3.1 (42.5-53.5)	40.7 ± 2.9 (35.6-48.4)	45.0 ± 2.8 (39.9-50.2)	78.7 ± 5.4 (67.1-89.1)	1.75 ± 0.11 (1.58-1.97)	5.1 ± 3.3 (-3.0-11.1)	5.6 ± 2.7 (2.5-15.1)	5.3 ± 2.5 (0.8-12.7)

Table 5. Tibial Measurements Categorized by Race and Sex

The present study showed that the dimensions of Chinese knees were generally smaller than white knees. In addition, Chinese females had a significantly narrower distal femur than white females, whereas Chinese males had a wider proximal tibia than their white counterparts. These results proved the hypothesis that there is a distinct difference in size and shape between the Chinese and white knees. [39] Harvey et al also showed that there are more valgus alignment of the distal femur in Chinese. [40]

A proper design of femoral aspect ratio of femoral TKA components is critical to obtain an ideal coverage of the resected bone surface. It must be noted that the differences in average values of femoral aspect ratio between Chinese and white females cannot be explained by differences in knee size alone, and this may point to a distinct variation in femoral shape between the 2 races. Given this, it is possible that the components designed based on white knee data may produce a mediolateral component overhang in Chinese females. [41]

The geometry of tibial plateau has a direct influence on the biomechanics of tibiofemoral joint and is considered as an important factor in TKA design and implantation. [9, 42]

The study by Yue et al. showed that Chinese subjects generally had a smaller size of proximal tibia than white subjects in both sexes. Interestingly, the tibial aspect ratio of Chinese males was significantly larger than that of white males (1.82 ± 0.07 vs 1.75 ± 0.11). However, the present study also found a larger tibial aspect ratio in small knees and a proportionally smaller ratio in large knees. Therefore, the differences of the tibial aspect ratios between the 2 groups may be caused by the average tAP dimensions of Chinese males that were generally smaller than those of white males. This study showed that there was no difference in medial/lateral posterior slope between Chinese and white subjects in either sex. [39]

4.5.2. Anthropometry of the Japanese proximal tibia

Uehara et al, in a comparative study between CT and intraoperative measurements of tibial dimensions, showed that the average ML length on the CT scan was significantly larger (74.3 ± 6.6 mm [mean \pm SD]) compared with the intraoperative measurement (71.4 ± 5.0 mm). In contrast, the average AP length on the CT scan was significantly smaller (48.3 ± 5.4 mm) compared with the intraoperative measurement (50.3 ± 3.6 mm). [43]

4.5.3. Variations between Japanese and Caucasian populations in the healthy young adult knee joint

Hovinga et al showed that there was a significant difference in alignment between Caucasian and Japanese groups. The mechanical alignment in Caucasians was slightly varus (0.55 ± 0.338 , 57%varus), while 78% of Japanese subjects exhibited a varus alignment (1.64 ± 0.438). A significant difference also existed between male and female subjects, with women exhibiting a higher percentage of valgus alignment (50%) than men (36%). The average torsion angle was 37.58 for all subjects. Tibial torsion measurements showed significant differences with ethnicity; Caucasians demonstrated a higher torsion angle than Japanese. No difference based on gender was observed. The tibial width for all subjects was 74.1 ± 0.77 mm. The lateral width was 39.4 ± 0.52 mm, while the medial width was 34.6 ± 0.42 mm. Medial and lateral widths were greater in males than in females, but no ethnic differences were found. The laxity measurement for Caucasian females was 6.4 ± 0.36 mm, and for males was 4.9 ± 0.35 mm. For Japanese females, the laxity was 8.1 ± 0.65 mm, and for males 6.9 ± 0.56 mm. Significant differences were found for both gender and ethnicity. [4]

Based on this study, a higher varus alignment, lower tibial torsion, and higher ACL laxity were found in Japanese compared to Caucasian populations. Males demonstrated a higher varus alignment, larger tibial width, and lower ACL laxity compared to females. [4]

Tamari et al performed a clinical study aimed to investigate whether or not there were ethnic, gender, and age-related differences in FTA and torsion of the lower limb among healthy Japanese and Australian Caucasian populations. They found that the Japanese had significantly greater FTA than the Australian Caucasians. Moreover, there was gender difference in this variable, that is, the female subjects had significantly smaller FTA than the males. The femoral antetorsion was significantly smaller in middle and older age groups compared to

the younger age group in the Japanese subjects. Femoral antetorsion of the Japanese was significantly greater than that of the Australian subjects. Further, the females had greater femoral antetorsion than the male subjects. They also found that the tibiofibular torsion was significantly larger in the younger and middle age groups compared to the older age group of the females, whereas there were no significant age-related differences in the male subjects. But, there was no ethnic difference in tibiofibular torsion. Tibiofibular torsion of the females was significantly smaller than that of the male subjects. [7]

4.5.4. Morphometry of the Korean proximal tibia

Kwak et al assessed the morphometry of the proximal tibia of Korean ethnicity. Their results are as follows. (Table 6)

4.5.4.1. ML and AP dimensions

The average mediolateral (ML) and middle anteroposterior (AP) dimensions for the Korean population were 73.5 ± 5.6 mm and 47.3 ± 3.8 mm, respectively. The males were found to have larger values for the AP and ML dimensions when compared to the females. Comparison of the AP and ML dimensions to the height of the person showed a statistically significant, positive correlation with the height of the person. [44]

4.5.4.2. Medial and lateral anteroposterior dimensions of the tibial condyle

The medial tibial plateau is larger than the lateral tibial plateau anteroposteriorly by an average of 3.9 ± 2.9 mm in the males and 3.7 ± 2.7 mm in the females. This result favors the need for asymmetry in the tibial component for the Korean population.

Accordingly, the gross size of the proximal tibia (ML and AP) in the females was found to be smaller than that in the males. Both the AP and ML lengths were found to be smaller than the Caucasian population. This research shows that the ML dimension is more strongly correlated to the height of the person when compared to the AP dimension. They also found that the MAP was located closer to the centre of the tibial plateau (C) as compared to the LAP, which further confirmed the asymmetry of the proximal tibia. [44]

This study revealed a higher aspect ratio for the smaller AP dimensions of the proximal tibia and a lower aspect ratio for the larger AP dimensions of the proximal tibia. In other words, this means that with every increase in the AP dimension of the proximal tibia, the shape of the anticipated tibial component becomes less oval (mediolaterally) for use in the Korean population. In the Japanese study, the aspect ratio in women varied from 138 to 142.86, however, they found that as the ML dimensions increased the aspect ratio increased. In contrast, to the pattern of the study population, the majority of the symmetric conventional implants showed a relatively constant aspect ratio or an increase in the aspect ratio (NexGen) with the increase of the AP dimension of the proximal cut. Thus, a tibial component that would be suitable for the Korean population would be one whose aspect ratio decreased with increase in the anteroposterior dimension. [44]

4.5.5. Anthropometric measurements of knee joints in Thai population

Chaichankul et al assessed the knee morphology in Thai population and found that the femoral aspect ratio and the tibial aspect ratio were significantly different between males and females. This study also demonstrated that when the tibial AP dimension increased, there was a decreasing tibial AP/ML aspect ratio, while most implants had a relatively constant aspect ratio. [45] (Table 7 and 8)

Parameter	Male	Female	Combined
Mediolateral length (ML)	76.1±4.0	67.64±3.12	71.9±5.6
Middle anteroposterior length (AP)	48.2±3.3	43.2±2.3	45.7±3.8
Medial anteroposterior (MAP)	48.5±3.7	43.5±2.9	45.9±4.2
Lateral anteroposterior (LAP)	44.6±3.2	39.8±2.5	42.2±3.7
Medial to centre distance (CM)	14.4±5.1	12.9±3.5	13.7±4.4
Lateral to centre distance (CL)	19.7±3.5	15.9±5.6	17.8±5.1
Aspect ratio	158	156	157
Height (cm)	165.9±4.8	156.4±5.0	161.2±6.8
MAP-LAP difference	3.9±2.9	3.7±2.7	3.8±2.8

Table 6. Average values (in mm) of the measured data from the cadavers

Parameters	Total	Male	Female
	Mean±SD (range)	Mean±SD (range)	Mean±SD (range)
Resected AP length (mm)	45.43±4.5 (35–56.9)	48.55±3.73 (40–56.9)	43.32±3.69 (35–55)
Resected ML width (mm)	64.06±6.31 (52–78.9)	70.15±3.87 (61.4–78.9)	59.91±3.75 (52–76.3)
Aspect ratio (ML width/AP length)×100	141±12 (111–177)	145±11 (124–177)	139±12 (111–177)

Table 7. The distal femoral condyle dimensions.

Parameters	Total	Male	Female
	Mean±SD (range)	Mean±SD (range)	Mean±SD (range)
Resected AP length (mm)	46.04±4.4 (37.6–56.6)	50.15±3.09 (44–56.6)	43.23±2.57 (37.6–52)
Resected ML width (mm)	68.8±5.8 (57.8–86)	74.44±3.44 (65.6–86)	64.95±3.45 (57.8–78.6)
Aspect ratio (ML width/AP length)×100	67±3 (59–77)	67±3 (61–75)	67±3 (59–77)

Table 8. The proximal tibial dimensions.

4.5.6. Anthropometric measurements of the Indian population

Vaidya et al examined the anthropometric characteristics of Indian normal knees by CT scan and dry bone measurement. They found that the mean anteroposterior diameter of the femur in men was 61.09 mm and in women was 55.58 mm. Most men (27 of 38) had a range of anteroposterior diameter between 55 and 65 mm, whereas most women (40 of 48) had a range between 49 and 59 mm. In the cadaveric study, the mean anteroposterior diameter was 55.26 mm, and most (19 of 25) had a range between 52 and 60 mm. [46]

Assuming the lowest cut-off value of the anteroposterior diameter of the lower end of the femur in the study population to be 55 mm (55 mm being the smallest size of commercially available prosthetic femoral component), it was observed that a statistically significant number of Indian population (approximately 40%) had measurements lower than this value. This percentage was more significant in women (60.4%), in whom the mean anteroposterior diameter was 52.01 mm, than in men. The clinical implication of this statistical analysis is that there is a substantial number of Indians in whom the problem of component oversizing is likely to occur. [46]

4.5.7. Morphology of proximal tibia in Iranian

4.5.7.1. Lateral offset of tibial shaft in relation to tibial plateau

In a study on Iranian normal adult knees, we assessed the tibial plateau shift angle (TPSA) in order to assess our hypothesis that the proximal tibia of Iranian knee is not the same as the western knees. TPSA is the angle formed between central line (Cs) of the tibial shaft and the mechanical axis of the tibia which goes through the central point (Cp) of the tibial articular surface and the center of ankle. Our results are shown in Table 9.

Parameter	Our study			Japanese			Americans			France
	Mean	SD	Range	Mean	SD	Range	Mean	SD	Range	Mean
TA	93.8	1.54	90.3-98	97.2	3.8	89-106	93	1.6	90-96.5	93
TPSA	2.11	3.64	-3.4-7.4	2.21	1.5	-3.0-7.0	-	-	-	-

Table 9. Representation of the amount of tibial shaft offset in Iranian and its comparison with other studies.

Our TPSA findings demonstrate that tibial plateau was not symmetrical and the Cp passes medial to Cs. This shows that the tibial plateaus in Iranian knees have a medial offset in regard to tibial shaft. So we consider that the center of the tibial plateau should not be used as a landmark of the tibial component.

4.5.7.2. Posterior tibial slope

We assessed the tibial slope in normal adults in Iran. The mean slope angle was 9.4 ± 1.8 degrees. We found no statistical relationship between age and gender and posterior tibial

slope. The normal posterior tibial slope angle in this Iranian population was different from other ethnic groups (Table 10). It may be necessary to consider these differences in designing tibial components for knee arthroplasty. [47]

Study	Ethnic group	Number	Range of slope (degrees)	Mean ± (SD)
Moore et al (1974)	American	50	7 – 22	14 ± 3.7
Jiang et al (1994)	Thai	50	0 – 20	10 ± 4
Matsuda et al (1999)	Japanese	30	5 – 15.5	10.7
Chiou et al (2000)	Chinese	25	5 – 22	14.7 ± 3.7
Our study (2009)	Iranian	108	2 – 18	9.4 ± 1.8

Table 10. Comparison of posterior tibial slope between Iranians and other ethnic groups

5. Patella

Patella-related problems are among the issues of concern during and after TKA. Information regarding anthropometric patellar dimensions can play an important role during the design of patellar prostheses and the development of surgical techniques. [48] Thickness, height/width ratio, and relative position of the median ridge all have implications relating to the selection of patellar components, patellofemoral contact stress, and patellar tracking in the trochlear groove. [49]

Patellar thickness is a challenging consideration during patellar resurfacing for TKA. A thin patella can reduce patellofemoral contact force but also poses the potential risk of stress fracture and anteroposterior instability. Increasing patellar thickness might be expected to increase effective quadriceps moment arm at low flexion angles of the knee but potentially reduces range of motion and predisposes to patellar subluxation. It commonly is assumed that it is desirable for a resurfaced patella to be equal to its original thickness, and a bony patellar thickness of at least 15 mm should be maintained. However, it is not uncommon to find, intraoperatively, the patella is too thin to simultaneously satisfy these criteria. Three surgical options should be considered with a thin patella: (1) leave the patella unresurfaced; (2) restore the original patellar thickness by removing bone to account for the thickness of the prosthesis, while accepting thin residual bone; and (3) leave residual bone of adequate thickness, while accepting an increase in overall patellar thickness. To solve this problem, the only versatile option is to use a specifically designed patellar prosthesis with less thickness. [9, 50]

Patellar height/width ratios and the position of the median patellar ridge have clinical implications for TKA with patellar resurfacing. Because the mediolateral width of a patella typi-

cally is larger than its height, a dome-shaped patella component chosen by the height does not cover the entire resected surface of the patella. It has been recommended the patella be placed at the medial margin of a resected patella to help patellofemoral tracking by decreasing the Q angle. In addition, the position of the median ridge is another factor to consider when selecting the size of a patellar component. The median ridge can act as a fulcrum for patellofemoral tracking and thus can influence restoration of normal kinematics after TKA with patellar resurfacing. If an orthopaedic surgeon attempts to restore the original position of the median ridge, he or she may have to select a smaller component, which reduces patellofemoral articulation contact area. [9]

The only article in the literature that we could find on this subject was by Kyun Kim et al. They performed an anthropometric assessment of patella on Korean knees (Figure 6) and its comparison to the western knees. They found that Koreans had thinner and smaller patellae than Westerners. The mean central ridge thickness was 21.2 mm in women and 23.1 mm in men, whereas corresponding reported mean thicknesses in Western patients are 21.8 to 22.5 mm and 23.9 to 26.1 mm. In Koreans, mean heights and widths were 33.1 mm and 41.0 mm in women and 36.2 mm and 45.6 mm in men, whereas corresponding values in Western patients are 35.0 mm and 42.7 mm in women and 39.4 mm and 49.5 mm in men. However, despite these differences in thicknesses, widths, and heights, the width/height ratios and ridge positions were similar in Koreans and Westerners. [50] (Table 11)

Some studies have advocated reestablishment of original thickness and adequate residual bony thickness as key surgical guidelines. However, in Korean patients, these two guidelines often cannot be satisfied. In such cases, the surgeon is forced to choose between restoring the original thickness while accepting a low residual bony thickness and retaining sufficient residual bony thickness while accepting an increased overall thickness. But if Koreans can have a specifically designed patellar prosthesis with less thickness, this problem will be better resolved. [51]

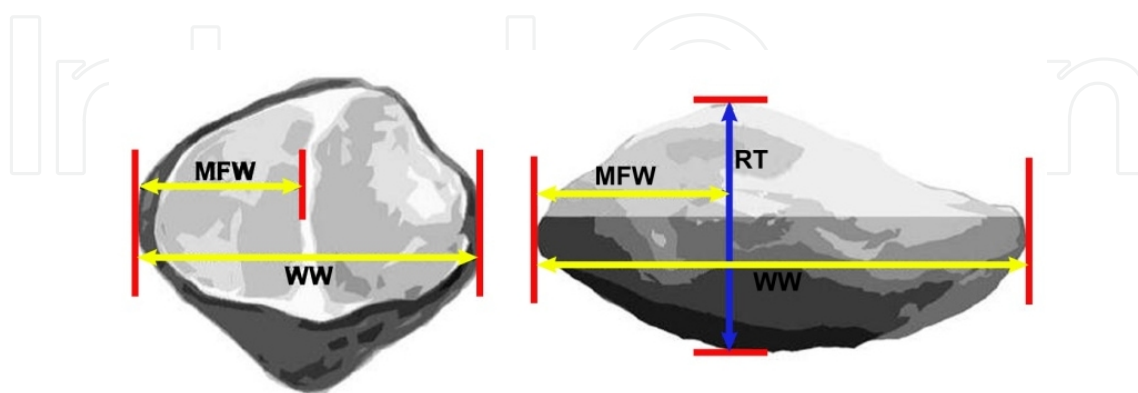

Figure 6. The schematic drawings show anthropometric dimensions before bone resection, including medial facet width (MFW), whole patella width (WW), and thickness at the median ridge (RT).

Study	Thickness at central ridge (mm)	Ridge position	Mediolateral width (mm)	Superoinferior height (mm)	Width/height Ratio	Residual bony thickness after bone resection (mm)	Overall thickness after implantation (mm)
This study							
Female (n = 713)	21.2 (17–26)	0.45 (0.23–0.67)	41.0 (25–51)	33.1 (23–43)	1.24 (0.72–1.78)	12.5 (10–15)	21.2 (17–25)
Male (n = 39)	23.1 (20–26)	0.44 (0.23–0.52)	45.6 (36–52)	36.2 (31–52)	1.27 (0.81–1.50)	13.5 (12–16)	22.7 (20–26)
Baldwin and House (2005)							
Female (n = 57)	21.8 (18–27)	0.43	42.7 (32–50)	35.0 (28–43)	1.22 (1.06–1.56)		
Male (n = 35)	23.9 (20–30)	0.42	49.5 (44–64)	39.4 (34–45)	1.26 (1.05–1.51)		
Chmell et al.(1996)							
Female (n = 123)	22.6 (17.5–28)						
Male (n = 75)	26.1 (20–33)						
Hitt et al.(2003)							
Female (n = 209)	22.5						
Male (n = 128)	25.3						

Table 11. Comparisons of the anthropometric dimensions of the patellae of Korean and Western patients (based on published values)

6. Is ethnicity influencing in vivo normal knee kinematics?

Current TKA reduces pain, restores mobility, and provides satisfactory longevity. Surgery is sometimes refused in non-Western cultures due to the anticipated limited postoperative ROM. [52]

Therefore, improvements to facilitate deep flexion activities are required in the present TKA designs to be accepted by Asian people. To make design changes, it is important to understand which factors influence deep flexion capabilities. Since Asian populations can achieve more flexion than Caucasians (156.9°, 157.3°, 159.6°, 160°, 162° or even 165° for Asian populations and 143.8°, 145° for Caucasian), ethnicity might reveal certain factors leading to higher knee flexion. [53 - 55]

Physiologic and anatomic characteristics can vary considerably between individuals. Research data originating from different regions of the world suggest ROM may be a function

of ethnicity or a lifestyle. Caucasians can flex to about 140° , while in societies where daily activities require full kneeling or squatting as in Japan, India, or the Middle East, subjects achieve up to 165° , providing an energy-saving flexed posture. Saudi Arabian men flex their knees, on average, to 159.6° , 15° more than Scandinavians. Muslims maintain the flexion of 157.3° in their prayer position. [54, 55]

Leszko et al. assessed the knee kinematics in Asian and Caucasian population. They found that Caucasian women achieved similar maximum flexion as the Japanese women and Japanese men. These three groups also outnumbered the Caucasian males capable of achieving knee flexion greater than 150° . Consequently, the average maximum flexion was lower for Caucasian men than for Caucasian women or Japanese men. These differences were also apparent when comparing the flexion ROM; the highest was attained by Japanese women, followed by Japanese men, Caucasian women, and Caucasian men. The maximum axial rotation was lower for Caucasian men compared to Caucasian women. Caucasian women and both Japanese groups achieved similar average maximum axial rotation. The absolute range of axial rotation revealed a similar trend; it was lower for Caucasian men than for the three other groups, and there was no difference among the three other groups. When compared at each flexion increment, the femur rotated externally with increasing flexion, in a similar pattern for all four groups. [9]

However, in deep flexion, Caucasian men had the least amount of external rotation. For all groups, the femur was slightly abducted at the beginning of the activity but adducted with increasing knee flexion. Above 120° of flexion, the femur remained about 4° adducted for Caucasian women and both Japanese groups, while for Caucasian men, the adduction reduced and the femur became slightly abducted at 150° of flexion. The lateral tibio-femoral contact point translated posteriorly in virtually the same pattern for all four groups and there was no difference at any flexion increment or in the absolute range of translation between any of the groups. The AP translation of the medial tibio-femoral contact point was also similar for all groups, except at maximum flexion where it was more posterior for Caucasian men than for Caucasian women. Similarly, the AP translation of the lateral femoral flexion facet center was similar between the groups at any flexion as was the medial femoral flexion facet center translation at each flexion increment. However, the posterior translation of the femoral flexion facet center from full extension to maximum flexion was higher for Caucasian men than for any other group. The medial and lateral condyles moved in different modes. The lateral condyle was spinning and rolling posteriorly throughout the ROM. However, the medial condyle counter-translated in the early flexion and then was spinning until 120° . Above 120° , the motion changed to more of a rolling type for both condyles, which may justify the use of the term "posterior femoral rollback." There were no differences in the type of motion of the lateral condyle between the analyzed groups at any flexion increment. However, above 120° of flexion, the medial condyle revealed more rolling for Caucasian men compared to Caucasian women and both Japanese groups. [9]

This study suggested higher axial rotation is not related to the lateral condyle, as its motion was almost identical for all three groups (the lateral femoral condyle was spinning and rolling in the same manner for all four groups). The differences were observed on the medial condyle.

From full extension to maximum flexion, for Caucasian men, the medial tibio-femoral contact point and flexion facet center translated more posteriorly than for any other group. The medial condyle was also rolling more for the Caucasian men than for any other group above 120°. In fact, for the three other groups, the medial condyle remained more stationary, spinning close to the center of the tibial plateau, possibly allowing the lateral condyle to pivot about it and to rotate more externally. The ability to achieve more external rotation may also be related to ACL laxity, as it was higher for Japanese than for Caucasians. [9]

7. Conclusion

Almost all prosthetic implants have been designed and manufactured to accommodate the knee anatomy of Western Caucasians, and there is some doubt about the application of these systems to Asians, as the size of Asians differs from that of Caucasians. Moreover, even if the smallest size from each Western prosthesis company is used, it may be too big for some Asian subjects.

However, all the problems with matching a conventional knee prosthesis with Asian knees is not the mere size. It is important not to consider Asian knees as a smaller western Caucasian knees. As we reviewed in above paragraphs, there are many differences in various anatomic parameters between Asian and Caucasian knees. In Chinese, Korean and Iranian knees, it has been shown that the tibial anatomic axis does not pass through the same point of plateau as the western Caucasian knees. It is a noteworthy point to consider while marking the tibial entry point, otherwise, in Asian knees, the tibial component would be inserted in varus or the tibial medial cortex would be fractured.

Besides, the relationship between these parameters in Asian knees are far different from western Caucasian knees. As it was described in multiple studies in Chinese, Japanese, Korean and Indian population, the mediolateral diameter of the distal femur is smaller than their counterpart in western population with the same AP diameter. There is also a more important aspect of difference between these two groups of knees, which is great disparity among changes in these parameters. In other words, in contrast to western Caucasian knees, there are some parameters in the Asian knees which decrease upon increasing the other parameters and the size of the knee. As it has been shown in Chinese knees, the femoral aspect ratio was higher for smaller knees and proportionally lower for larger knees and female subjects had a smaller aspect ratio with the same anteroposterior dimension. On the tibial side, the aspect ratio (tML/tAP %) showed a definitely negative correlation with tAP, which means that there were large values in the aspect ratio with the smaller tAP, and that males have larger values in the aspect ratio than females having the same values for anteroposterior dimension. Although, there are some prostheses that consider this negative correlation between tibial aspect ratio and tAP, however, the rate of change did not match that of the Asian population.

There is also a huge number of differences in the angular parameters between Asian and western Caucasian knees. Distal femoral coronal angle, posterior femoral condylar angle,

proximal tibial varus angle and posterior tibial slope have all been shown to be different in Asian from western Caucasian knees. It means that standard considerations while preparing and cutting distal femur and proximal tibia may not be appropriate for Asian knees, otherwise, soft tissue tension, ligament balancing and ROM of the joint may be disturbed.

Patellar dimensions are also different between these two ethnic groups, so although specific considerations in patellar resurfacing techniques for Asians are necessary, a specifically designed patellar prosthesis with less thickness is imperative to accommodate thinner patella of Asian ethnicity.

Aside from technical considerations for Asian knees which of course must be different from western knees, there seems to be necessary to have some specifically designed knee prostheses for Asian population. These prostheses must take into account not only the differences in size, but also the variations in aspect ratios in size parameters and their specific changes with changes in other parameters. Another consideration in Asian knee prostheses is their need for more flexion than their western counterparts. For achieving deep flexion after TKA, prosthesis design, although not as important as the technical consideration, is an significant point.

8. Summary

As you've read through the chapter it is clear that knees are different in different ethnic population.

These differences vary in a wide spectrum. For example, three-dimensional morphology of the Knee represents that the shape of the distal femur and proximal tibia is different among the ethnic groups. The normalized ratios and nonlinear shape analysis of the studies supported differences between East Asians and Caucasians independent of any scale factor.

There is a strong correlation between the femoral mediolateral (fML) and femoral anteroposterior (fAP) dimensions with the tibial mediolateral (tML) measurements, and as the latter increases, there is an increase in the formers.

Quantification of the tML and tAP (tibial anteroposterior) revealed that among Chinese population females have a smaller tibial surface than males, and both have smaller values than the Caucasian population. The morphologic data of the tibia showed a decreasing aspect ratio (tML/tAP %) as the tAP dimension increased, which is similar in many studies. In contrast, a majority of the implants had a relatively constant aspect ratio. Comparing five major conventional prostheses, it is evident that tML is undersized with the smaller tAP, and overhang with the larger tAP. This is more evident in male knees. In the morphology of the femur, females have a smaller aspect ratio with the same femoral anteroposterior dimension, which suggest that women have generally narrower femora than men when the femoral anteroposterior dimension is adequate. These results suggest that the prostheses which are suitable for Caucasian patients may be larger than ideal for Chinese patients. Since the tML is strongly correlated with the fML and fAP, it is important to consider the tibia and femur

as a whole. Therefore, the tML and fAP should be considered as the criteria to design gender-specific proper prostheses suitable for most of Chinese population.

Dimensions of Chinese knees were generally smaller than white knees. In addition, Chinese females had a significantly narrower distal femur than white females, whereas Chinese males had a wider proximal tibia than their white counterparts. These prove the hypothesis that there is a distinct difference in size and shape between the Chinese and white knees. Another point is that the femoral condyles are asymmetric among Chinese population.

Anatomical differences could be observed even during childhood developments. Arazi et al found a negative correlation between the weight of children at a specific age with the ICD of the subject. However, this correlation was found to be weak and although statistically significant, it might not be of any clinical significance. The only possible explanation to this might be the relatively thick thighs of the heavier children, which is expected to subjectively decrease the ICD. Literature shows that there is a wide variation in the normal development of the knee angle, which might be physiological.

Axial alignment of the lower extremity has also seemed to be different among different races. Achieving normal axial alignment of the lower extremity is important to surgeons who perform reconstructive surgery of the knee.

In the study by Tang et al, the extremities of Chinese women had a mean of 2.2 ± 2.5 degrees of varus alignment, demonstrating that the knees of Chinese female is in more varus alignment than those in the white females.

Several studies have revealed that the axis of the tibial shaft is, on the average, located anteromedial to the center of the tibial plateau in the Western population, for whom a medially offset stem seems more suitable. But, some studies confirm that the axis of the tibial shaft does not overlap the center of the tibial plateau in Chinese people. It seems that an offset stem would be more suitable for Chinese patients who need a long-stemmed tibial component. Among Asian population, there is a large variation in the offset of the tibial shaft from the tibial plateau, ranging from 0.46 to 12.26 mm.

In a study on Iranian normal adult knees, we assessed the tibial plateau shift angle (TPSA) in order to assess our hypothesis that the proximal tibia of Iranian knee is not the same as the western knees. Our TPSA findings demonstrate that tibial plateau was not symmetrical and the central point (Cp) passes medial to central shaft line (Cs). This shows that the tibial plateaus in Iranian knees have a medial offset in regard to tibial shaft. So we suggest that the center of the tibial plateau should not be used as a landmark of the tibial component. Therefore, some tibial base-plates specifically designed for Caucasians may not be suitable for Asian people and it remains a necessity to design a special tibial base-plate for these ethnic groups.

Some variances have also been observed in sagittal femoral shaft bowing. In Chinese patients distal sagittal bowing is a constant and important feature, and it affects the positioning of the femoral component on the sagittal plane. There is a dilemma of implanting the femoral component either according to the anatomy of the distal femur ignoring the

bowing, or according to the longitudinal axis of the femur on the sagittal plane. On one hand, following the distal anatomy might sufficiently flex the femoral component that it results in an undesirable impingement of the anterior aspect of the polyethylene post on knee extension if posterior-stabilized implants are used and thus become a source of osteolysis-inducing polyethylene particles. However, following the longitudinal axis of the femur might result in an extended femoral component that could compromise the anterior cortex of the distal femur. In Chinese patients who have undergone TKA, distal sagittal bowing of the femur is common but the common pattern is posteromedial osteoarthritis. This apparent inconsistency could be the result of differences in tibial slope and the joint line obliquity in Chinese patients.

The posterior tibial slope has also a unique feature in Asians. Kapandji found that the tibial plateau was inclined posteriorly for 5° to 6° according to the horizontal plane and called this *retroversion* in the sagittal plane of the tibia. We assessed the tibial slope in normal adults in Iran. The mean slope angle was 9.4 ± 1.8 degrees. We found no statistical relationship between age and gender and posterior tibial slope. The normal posterior tibial slope angle in this Iranian population was different from other ethnic groups. It may be necessary to consider these differences in designing tibial components for knee arthroplasty.

Special considerations in total knee arthroplasty for Asians: Recent anthropometric studies have suggested that current design of total knee arthroplasty (TKA) does not cater to racial anthropometric differences. Most of the commercially available TKA prostheses are designed according to the anthropometric data of white knees, which has been suspected as the cause of the component mismatch in Asian people. Several studies have compared the morphology of Asian knees to that of TKA prostheses currently used in Asia and found that the femoral aspect ratio (medio-lateral [fML]/antero-posterior [fAP]) of these prostheses were not suitable for Asian patients.

Patella-related problems are among the issues of concern during and after TKA. Information regarding anthropometric patellar dimensions can play an important role during the design of patellar prostheses and the development of surgical techniques. Thickness, height/width ratio, and relative position of the median ridge all have implications relating to the selection of patellar components, patella-femoral contact stress, and patellar tracking in the trochlear groove. The only article in the literature that we could find on this subject was by Kyun Kim et al. They found that Koreans had thinner and smaller patellae than Westerners. Patellar thickness is a challenging consideration during patellar resurfacing for TKA. A thin patella can reduce patella-femoral contact force but also poses the potential risk of stress fracture and anteroposterior instability. It commonly is assumed that it is desirable for a resurfaced patella to be equal to its original thickness, and a bony patellar thickness of at least 15 mm should be maintained. However, it is not uncommon to find, intra-operatively, the patella is too thin to simultaneously satisfy these criteria. To solve this problem, the only versatile option is to use exclusively designed patellar prosthesis with less thickness.

Yet the importance of these issues is more distinguished when one considers the geographical variation in the epidemiology of osteoarthritis, which has been well documented. The ratio of knee osteoarthritis to hip osteoarthritis is 9:1 for Chinese individuals in Hong Kong,

3:1 for white individuals in the United States, and 1:2 for Swedish individuals. The racial differences in the axial alignment of the lower extremity may contribute to the variation in this ratio. The authors suspect that the larger knee-joint-obliquity angle in Chinese individuals may contribute to the higher ratio of knee osteoarthritis to hip osteoarthritis among Chinese adults.

One should be cautious in describing what is “normal” because of the substantial individual variations. Currently, designers of most total knee arthroplasty systems recommend placement of the components in such a way that the transverse axis of the artificial knee joint is perpendicular to the mechanical axes of the tibia and the femur. The resulting alignment of the lower extremity, therefore, is in close proximity to the alignment documented by Moreland et al. and Hsu et al. The mechanical axes of the femur and the tibia did not form a straight line in either Chinese males or females. This finding is in contrast to the general consensus that has been described previously.

And ultimately, the answer to this question: “Are in vivo normal knee kinematics influenced by ethnicity?” is, **YES**.

Author details

Hamid Reza Seyyed Hosseinzadeh^{1*}, Samih Tarabichi², Ali Sina Shahi¹, Mehrnoush Hassas Yeganeh¹, Usama Hassan Saleh², Gholam Reza Kazemian¹ and Aidin Masoudi¹

*Address all correspondence to: hhosseinzadehmd@yahoo.com

1 Shahid Beheshti University of Medical Sciences, Tehran, Iran

2 American Hospital, Dubai, United Arab Emirates

References

- [1] Hofmann S, et al. Bone Cuts and Implant Positioning to Achieve High Flexion. *Techniques in Knee Surgery*, 2011; 10(2): 77-86.
- [2] Bellemans J et al. Both Morphotype and Gender Influence the Shape of the Knee in Patients Undergoing TKA. *Clin Orthop Relat Res* (2010) 468:29–36
- [3] Gillespie RJ, et al. Gender differences in the anatomy of the distal femur. *J Bone Joint Surg Br.* 201;93(3):357-63.
- [4] Hovinga KR, et al. (2009). Anatomic variations between Japanese and Caucasian populations in the healthy young adult knee joint. *J Orthop Res.* 2009;27(9):1191-6.

- [5] Iorio R, et al. Primary posterior cruciate-retaining total knee arthroplasty: a comparison of American and Japanese cohorts. *J Surg Orthop Adv.* 2007 Winter;16(4):164-70.
- [6] Kamarul T, et al. Normal Anterior Cruciate ligament Laxity in the Malaysian Population. *J Malaysian Orthopaedic.* 2007; Vol 1: No 2.
- [7] Tamari K, et al. Ethnic-, Gender-, and Age-Related Differences in Femorotibial Angle, Femoral Antetorsion, and Tibiofibular Torsion. *Clinical Anatomy* 19:59–67 (2006)
- [8] Henry D, et al. Restoration of Femoral Anatomy in TKA With Unisex and Gender-specific Components. *Clin Orthop Relat Res* (2008) 466:2711–2716
- [9] Hitt K, et al. Anthropometric Measurements of the Human Knee: Correlation to the Sizing of Current Knee Arthroplasty Systems. *J Bone Joint Surg Am.* 85-A; Supplement 4: 2003
- [10] Conley S, et al. The Female Knee: Anatomic Variations. *J Am Acad Orthop Surg* 2007;15 (suppl 1):S31-S36
- [11] Mahfouz M, et al. Three-dimensional morphology of the knee reveals ethnic differences. *Clin Orthop Relat Res.* 2012;470(1):172-85.
- [12] Nelson AE, et al. Static knee alignment measurements among Caucasians and African-Americans: The Johnston County Osteoarthritis Project. *J Rheumatol* 2009;36(9): 1987–1990
- [13] Yue B, et al. Gender differences in the knees of Chinese population. *Knee Surg Sports Traumatol Arthrosc.* 2011;19(1):80-8.
- [14] Leszko F, et al. Comparison of in vivo patellofemoral kinematics for subjects having high-flexion total knee arthroplasty implant with patients having normal knees. *J Arthroplasty.* 2010;25(3):398-404.
- [15] Espandar R, et al. Angular Deformities of the Lower Limb in Children. *Asian Journal of Sports Medicine,* 2010;Vol 1 (No 1): 46-53
- [16] Sabharwal S, Zhao C. The Hip-Knee-Ankle Angle in Children: Reference Values Based on a Full-Length Standing Radiograph. *J Bone Joint Surg Am.* 2009;91:2461-8
- [17] Tang WM, Zhu YH, Chiu KY. Axial alignment of the lower extremity in Chinese adults. *J Bone Joint Surg Am.* 2000; 82-A(11):1603-8.
- [18] Saini UC, et al. Normal development of the knee angle in healthy Indian children: a clinical study of 215 children. *J Child Orthop.* 2010;4(6):579-86.
- [19] Cheng N, Shi QY. Rehabilitation exercises after single total knee replacement: a report of 38 cases. *Zhongguo Gu Shang.* 2010; 23(3): 220-1.(Abstract)
- [20] Arazi M, et al. Normal development of the tibiofemoral angle in children: a clinical study of 590 normal subjects from 3 to 17 years of age. *J Pediatr Orthop.* 2001; 21(2): 264-7.

- [21] Heath CH, Staheli LT. Normal limits of knee angle in white children—genu varum and genu valgum. *J Pediatr Orthop*. 1993; 13(2): 259-62.
- [22] Yoo JH, et al. Development of tibiofemoral angle in Korean children. *J Korean Med Sci*. 2008; 23(4): 714-7.
- [23] Oginni LM, et al. Knee angles and rickets in nigerian children. *J Pediatr Orthop*. 2004; 24(4): 403-7.
- [24] Moreland JR, et al. Radiographic analysis of the axial alignment of the lower extremity. *J Bone Joint Surg Am*. 1987; 69(5): 745-9.
- [25] Hsu RW, et al. Normal axial alignment of the lower extremity and load-bearing distribution at the knee. *Clin Orthop Relat Res*. 1990; (255): 215-27.
- [26] Fang Y, et al. The biomechanical study of rotating-arm self-locking intramedullary nails in comminuted femoral shaft fractures. *Sheng Wu Yi Xue Gong Cheng Xue Za Zhi*. 2006 Oct;23(5):1041-4.(Abstract)
- [27] Mullaji AB, et al. Distal femoral rotational axes in Indian knees. *J Orthop Surg (Hong Kong)*. 2009; 17(2): 166-9.
- [28] Tang WM, et al. Sagittal bowing of the distal femur in Chinese patients who require total knee arthroplasty. *J Orthop Res*. 2005; 23(1): 41-5.
- [29] Cheng FB, et al. Three dimensional morphometry of the knee to design the total knee arthroplasty for Chinese population. *Knee*. 2009; 16(5): 341-7..
- [30] Yip DK, et al. Distal rotational alignment of the Chinese femur and its relevance in total knee arthroplasty. *J Arthroplasty* 2004; 19: 613.
- [31] Tang Q, et al. The offset of the tibial shaft from the tibial plateau in Chinese people. *J Bone Joint Surg Am*. 2010. 18; 92(10): 1981-7.
- [32] Hicks CA, et al. The anatomy of the tibial intramedullary canal. *Clin Orthop Relat Res*. 1995; 321: 111-16.
- [33] Westrich GH, et al. Resection specimen analysis of proximal tibial anatomy based on 100 total knee arthroplasty specimens. *J Arthroplasty*. 1995; 10: 47-51.
- [34] Wevers HW, et al. Improved fit by asymmetric tibial prosthesis for total knee arthroplasty. *Med Eng Phys*. 1994;16: 297-300.
- [35] Abraham R, et al. An anatomical study of tibial metaphyseal/diaphyseal mismatch during revision total knee arthroplasty. *J Arthroplasty*. 2007 Feb; 22(2): 241-4.
- [36] Yoo JH, et al. The relationship of the medially-offset stem of the tibial component to the medial tibial cortex in total knee replacements in Korean patients,. *J Bone Joint Surg [Br]* 2008; 90-B: 31-6
- [37] Kapandji IA. The knee ligaments as determinants of trochleo-condylar profile. *Med Biol Illus*. 1967; 17(1): 26-32.(Abstract)

- [38] Chiu KY, et al. Posterior slope of tibial plateau in Chinese. *J Arthroplasty*. 2000; 15(2): 224-7.
- [39] Yue B, et al. Differences of Knee Anthropometry Between Chinese and White Men and Women. *J Arthroplasty*. 2011; Vol. 26: No. 1
- [40] Harvey WF, et al. Knee alignment differences between Chinese and Caucasian subjects without osteoarthritis. *Ann Rheum Dis*. 2008; 67(11): 1524-8.
- [41] Hosaka K, et al. Asian-Specific total knee system: 5-14 year follow-up study. *Musculoskeletal Disorders* 2011, 12:251
- [42] Hashemi J, et al. The Geometry of the Tibial Plateau and Its Influence on the Biomechanics of the Tibiofemoral Joint. *J Bone Joint Surg Am*. 2008; 90-A: 12.
- [43] Uehara K, et al. Anthropometry of the proximal tibia to design a total knee prosthesis for the Japanese population. *J Arthroplasty*. 2002; 17(8): 1028-32.
- [44] Kwak DS, et al. Morphometry of the proximal tibia to design the tibial component of total knee arthroplasty for the Korean population. *Knee*. 2007; 14(4): 295-300.
- [45] Chaichankul C, et al. Anthropometric measurements of knee joints in Thai population: correlation to the sizing of current knee prostheses. *Knee*. 2011; 18(1): 5-10.
- [46] Vaidya SV, et al. Anthropometric measurements to design total knee prostheses for the Indian population. *J Arthroplasty*. 2000; 15(1): 79-85.
- [47] Hosseinzadeh HR, et al. Measurement of Posterior Tibial Slope. *Iranian Journal of Orthopaedic Surgery* Vol 9, No 2, Spring 2010:121-5
- [48] Hsu HC, et al. Influence of patellar thickness on patellar tracking and patellofemoral contact characteristics after total knee arthroplasty. *J Arthroplasty*. 1996; 11: 69-80.
- [49] Baldwin JL, House CK. Anatomic dimensions of the patella measured during total knee arthroplasty. *J Arthroplasty*. 2005; 20: 250-257.
- [50] Kim TK, et al. Clinical implications of anthropometric patellar dimensions for TKA in Asians. *Clin Orthop Relat Res*. 2009; 467(4): 1007-14.
- [51] Koh JS, et al. Influence of patellar thickness on results of total knee arthroplasty: does a residual bony patellar thickness of 12 mm lead to poorer clinical outcome and increased complication rates? *J Arthroplasty*. 2002; 17: 56-61.
- [52] Noble PC, et al. Does total knee replacement restore normal knee function? *Clin Orthop Relat Res*. 2005; 431: 157-165.
- [53] Hemmerich A, et al. Hip, knee, and ankle kinematics of high range of motion activities of daily living. *J Orthop Res*. 2006; 24: 770-781.
- [54] Freeman MA, Pinskerova V. The movement of the knee studied by magnetic resonance imaging. *Clin Orthop Relat Res*. 2003; 410: 35-43.

- [55] Freeman MA, Pinskerova V. The movement of the normal tibiofemoral joint. *J Biomech.* 2005; 38: 197–208.

IntechOpen

IntechOpen

