

We are IntechOpen, the world's leading publisher of Open Access books Built by scientists, for scientists

4,800

Open access books available

122,000

International authors and editors

135M

Downloads

Our authors are among the

154

Countries delivered to

TOP 1%

most cited scientists

12.2%

Contributors from top 500 universities



WEB OF SCIENCE™

Selection of our books indexed in the Book Citation Index
in Web of Science™ Core Collection (BKCI)

Interested in publishing with us?
Contact book.department@intechopen.com

Numbers displayed above are based on latest data collected.

For more information visit www.intechopen.com



Techno-Economic Analysis of Different Energy Storage Technologies

Hussein Ibrahim and Adrian Ilinca

Additional information is available at the end of the chapter

<http://dx.doi.org/10.5772/52220>

1. Introduction

Overall structure of electrical power system is in the process of changing. For incremental growth, it is moving away from fossil fuels - major source of energy in the world today - to renewable energy resources that are more environmentally friendly and sustainable [1]. Factors forcing these considerations are (a) the increasing demand for electric power by both developed and developing countries, (b) many developing countries lacking the resources to build power plants and distribution networks, (c) some industrialized countries facing insufficient power generation and (d) greenhouse gas emission and climate change concerns. Renewable energy sources such as wind turbines, photovoltaic solar systems, solar-thermo power, biomass power plants, fuel cells, gas micro-turbines, hydropower turbines, combined heat and power (CHP) micro-turbines and hybrid power systems will be part of future power generation systems [2-8].

Nevertheless, exploitation of renewable energy sources (RESs), even when there is a good potential resource, may be problematic due to their variable and intermittent nature. In addition, wind fluctuations, lightning strikes, sudden change of a load, or the occurrence of a line fault can cause sudden momentary dips in system voltage [4]. Earlier studies have indicated that energy storage can compensate for the stochastic nature and sudden deficiencies of RESs for short periods without suffering loss of load events and without the need to start more generating plants [4], [9], [10]. Another issue is the integration of RESs into grids at remote points, where the grid is weak, that may generate unacceptable voltage variations due to power fluctuations. Upgrading the power transmission line to mitigate this problem is often uneconomic. Instead, the inclusion of energy storage for power smoothing and voltage regulation at the remote point of connection would allow utilization of the power and could offer an economic alternative to upgrading the transmission line.

The current status shows that several drivers are emerging and will spur growth in the demand for energy storage systems [11]. These include: the growth of stochastic generation from renewables; an increasingly strained transmission infrastructure as new lines lag behind demand; the emergence of micro-grids as part of distributed grid architecture; and the increased need for reliability and security in electricity supply [12]. However, a lot of issues regarding the optimal active integration (operational, technical and market) of these emerging energy storage technologies into the electric grid are still not developed and need to be studied, tested and standardized. The integration of energy storage systems (ESSs) and further development of energy converting units (ECUs) including renewable energies in the industrial nations must be based on the existing electric supply system infrastructure. Due to that, a multi-dimensional integration task regarding the optimal integration of energy storage systems will result.

The history of the stationary Electrical Energy Storage (EES) dates back to the turn of the 20th century, when power stations were often shut down overnight, with lead-acid accumulators supplying the residual loads on the direct current networks [13–15]. Utility companies eventually recognised the importance of the flexibility that energy storage provides in networks and the first central station for energy storage, a Pumped Hydroelectric Storage (PHS), was put to use in 1929 [13,16,17]. The subsequent development of the electricity supply industry, with the pursuit of economy of scale, at large central generating stations, with their complementary and extensive transmission and distribution networks, essentially consigned interest in storage systems up until relatively recent years. Up to 2005, more than 200 PHS systems were in use all over the world providing a total of more than 100 GW of generation capacity [16–18]. However, pressures from deregulation and environmental concerns lead to investment in major PHS facilities falling off, and interest in the practical application of EES systems is currently enjoying somewhat of a renaissance, for a variety of reasons including changes in the worldwide utility regulatory environment, an ever-increasing reliance on electricity in industry, commerce and the home, power quality/quality-of-supply issues, the growth of renewable as a major new source of electricity supply, and all combined with ever more stringent environmental requirements [14,19-20]. These factors, combined with the rapidly accelerating rate of technological development in many of the emerging EESs, with anticipated unit cost reductions, now make their practical applications look very attractive on future timescales of only a few years.

This document aims to review the state-of-the-art development of EES technologies including PHS [18,21], Compressed Air Energy Storage system (CAES) [22–26], Battery [27–31], Flow Battery [14-15,20,32], Fuel Cell [33-34], Solar Fuel [15,35], Superconducting Magnetic Energy Storage system (SMES) [36–38], Flywheel [32,39-41], Capacitor and Supercapacitor [15,39], and Thermal Energy Storage system (TES) [42–50]. Some of them are currently available and some are still under development. The applications, classification, technical characteristics, research and development (R&D) progress and deployment status of these EES technologies will be discussed in the following sections.

2. Electrical energy storage

2.1. Definition of electrical energy storage

Electrical Energy Storage (EES) refers to a process of converting electrical energy from a power network into a form that can be stored for converting back to electrical energy when needed [13–14,51]. Such a process enables electricity to be produced at times of either low demand, low generation cost or from intermittent energy sources and to be used at times of high demand, high generation cost or when no other generation means is available [13–15,19,51] (Figure 1). EES has numerous applications including portable devices, transport vehicles and stationary energy resources [13-15], [19-20], [51-54]. This document will concentrate on EES systems for stationary applications such as power generation, distribution and transition network, distributed energy resource, renewable energy and local industrial and commercial customers.

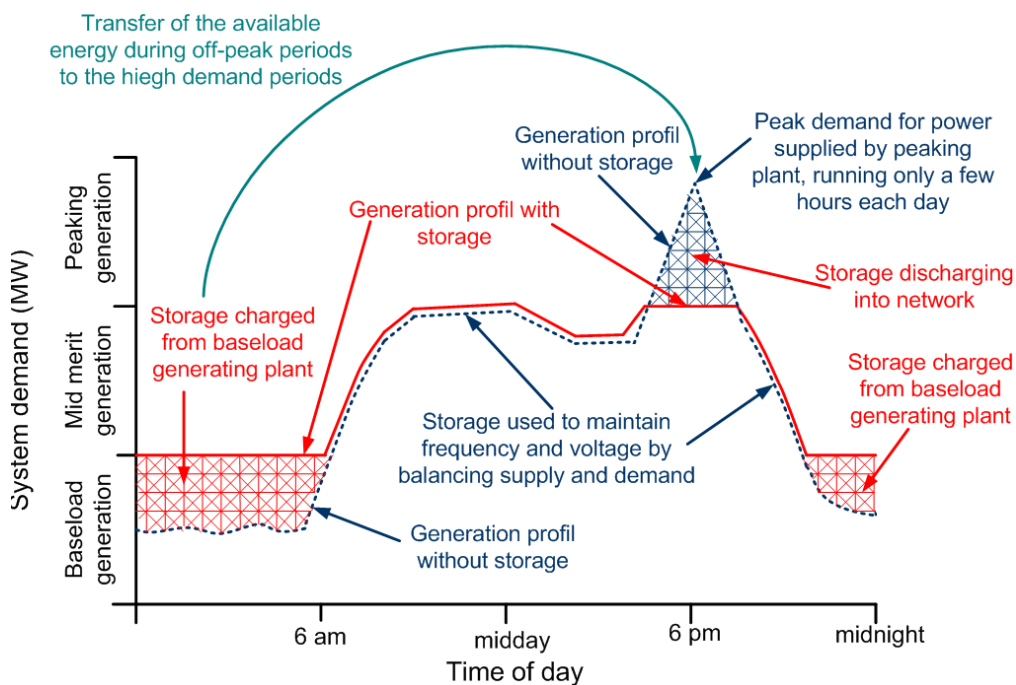

Figure 1. Fundamental idea of the energy storage [55]

2.2. Role of energy storage systems

Breakthroughs that dramatically reduce the costs of electricity storage systems could drive revolutionary changes in the design and operation of the electric power system [52]. Peak load problems could be reduced, electrical stability could be improved, and power quality disturbances could be eliminated. Indeed, the energy storage plays a flexible and multifunctional role in the grid of electric power supply, by assuring more efficient management of available power. The combination with the power generation systems by the conversion of renewable energy, the Energy Storage System (ESS) provide, in real time, the balance between production and consumption and improve the management and the reliability of the grid [56]. Furthermore, the ESS makes easier the integration of the renewable

resources in the energy system, increases their penetration rate of energy and the quality of the supplied energy by better controlling frequency and voltage. Storage can be applied at the power plant, in support of the transmission system, at various points in the distribution system and on particular appliances and equipments on the customer's side of the meter [52].

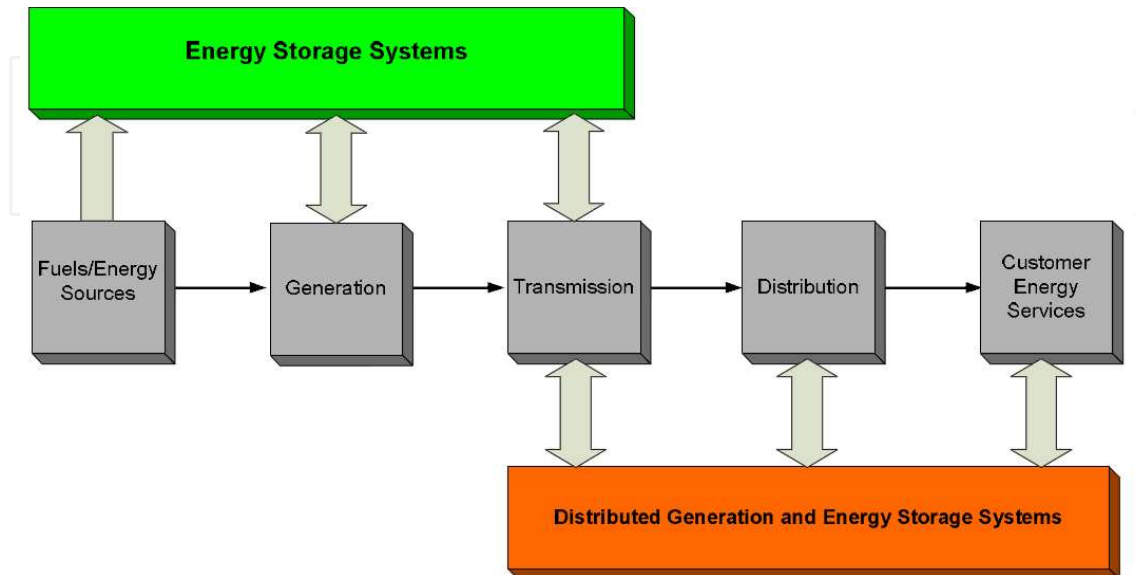

Figure 2. New electricity value chain with energy storage as the sixth dimension [11]

The ESS can be used to reduce the peak load and eliminate the extra thermal power plant operating only during the peak periods, enabling better utilization of the plant functioning permanently and outstanding reduction of emission of greenhouse gases (GHG) [57]. Energy storage systems in combination with advanced power electronics (power electronics are often the interface between energy storage systems and the electrical grid) have a great technical role and lead to many financial benefits. Some of these are summarized in the following sections. Figure 2 shows how the new electricity value chain is changing supported by the integration of energy storage systems (ESS). More details about the different applications of energy storage systems will be presented in the section 4.

3. Energy storage components

Before discussing the technologies, a brief explanation of the components within an energy storage device are discussed. Every energy storage facility is comprised of three primary components [58]:

- Storage Medium
- Power Conversion System (PCS)
- Balance of Plant (BOP)

3.1. Storage medium

The storage medium is the 'energy reservoir' that retains the potential energy within a storage device. It ranges from mechanical (Pumped Heat Electricity Storage – PHES),

chemical (Battery Energy Storage - BES) and electrical (Superconductor Magnetic Energy Storage – SMES) potential energy [58].

3.2. Power Conversion System (PCS)

It is necessary to convert from Alternating Current (AC) to Direct Current (DC) and vice versa, for all storage devices except mechanical storage devices e.g. PHES and CAES (Compressed Air Energy Storage) [59]. Consequently, a PCS is required that acts as a rectifier while the energy device is charged (AC to DC) and as an inverter when the device is discharged (DC to AC). The PCS also conditions the power during conversion to ensure that no damage is done to the storage device.

The customization of the PCS for individual storage systems has been identified as one of the primary sources of improvement for energy storage facilities, as each storage device operates differently during charging, standing and discharging [59]. The PCS usually costs from 33% to 50% of the entire storage facility. Development of PCSs has been slow due to the limited growth in distributed energy resources e.g. small scale power generation technologies ranging from 3 to 10,000 kW [60].

3.3. Balance-of-Plant (BOP)

These are all the devices that [58]:

- Are used to house the equipment
- Control the environment of the storage facility
- Provide the electrical connection between the PCS and the power grid

It is the most variable cost component within an energy storage device due to the various requirements for each facility. The BOP typically includes electrical interconnections, surge protection devices, a support rack for the storage medium, the facility shelter and environmental control systems [59].

The balance-of-plant includes structural and mechanical equipment such as protective enclosure, Heating/Ventilation/Air Conditioning (HVAC), and maintenance/auxiliary devices. Other BOP features include the foundation, structure (if needed), electrical protection and safety equipment, metering equipment, data monitoring equipment, and communications and control equipment. Other cost such as the facility site, permits, project management and training may also be considered here [61].

4. Applications and technical benefits of energy storage systems

The traditional electricity value chain has been considered to consist of five links: fuel/energy source, generation, transmission, distribution and customer-side energy service as shown in Figure 3. By supplying power when and where needed, ESS is on the brink of becoming the “sixth link” by integrating the existing segments and creating a more responsive market [62]. Stored energy integration into the generation-grid system is

illustrated in Figure 4 [32]. It can be seen that potential applications of EES are numerous and various and could cover the full spectrum ranging from larger scale, generation and transmission-related systems, to those primarily related to the distribution network and even ‘beyond the meter’, into the customer/end-user site [13]. Some important applications have been summarised in [13–15], [32], [52], [62–66]:

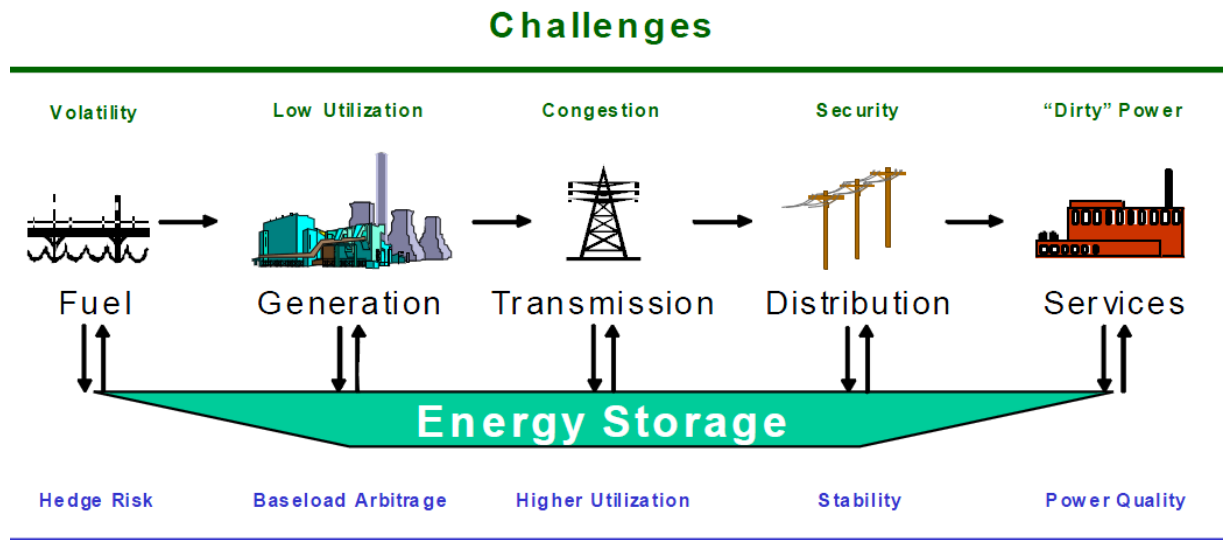

Benefits

Figure 3. Benefits of ESS along the electricity value chain [62].

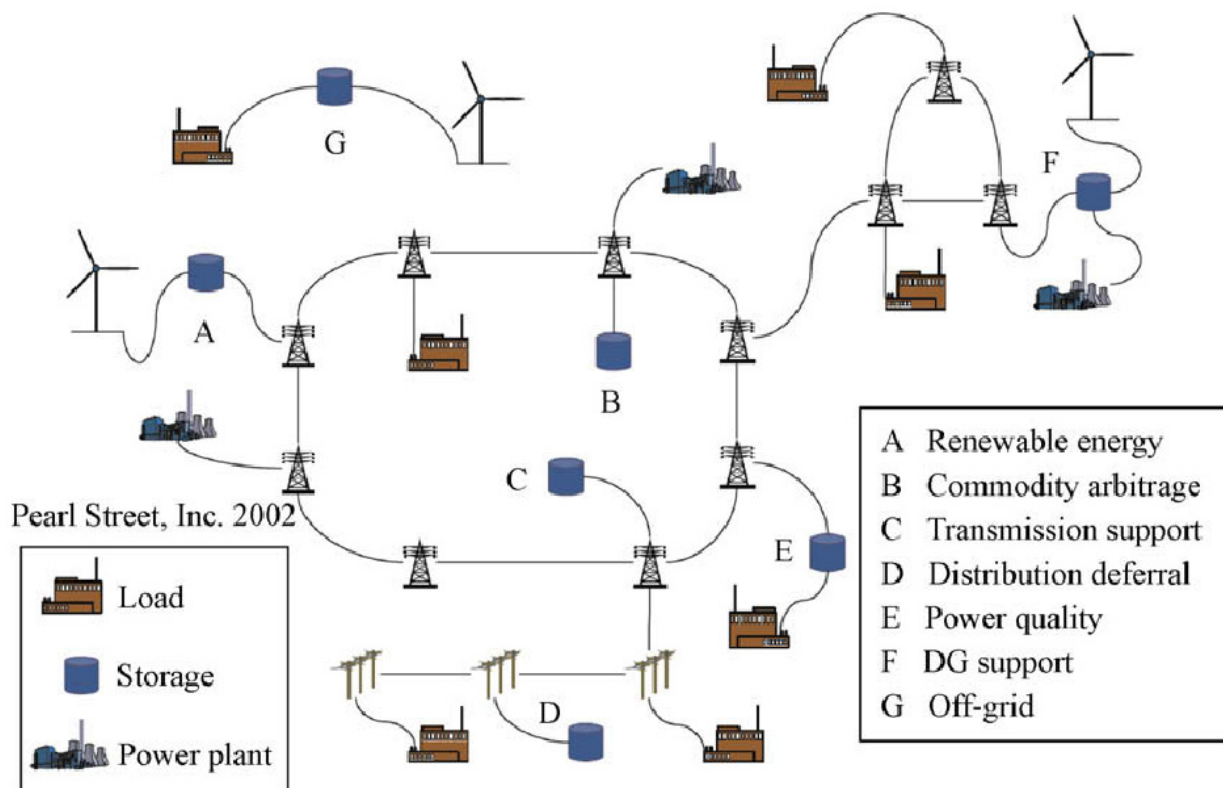

Figure 4. Energy storage applications into grid [32].

4.1. Generation

- *Commodity Storage*: Storing bulk energy generated at night for use during peak demand periods during the day. This allows for arbitrating the production price of the two periods and a more uniform load factor for the generation, transmission, and distribution systems [62].
- *Contingency Service*: Contingency reserve is power capacity capable of providing power to serve customer demand should a power facility fall off-line. Spinning reserves are ready instantaneously, with non-spinning and long-term reserves ready in 10 minutes or longer. Spinning Reserve is defined as the amount of generation capacity that can be used to produce active power over a given period of time which has not yet been committed to the production of energy during this period [67].
- *Area Control*: Prevent unplanned transfer of power between one utility and another.
- *Grid Frequency Support*: Grid Frequency Support means real power provided to the electrical distribution grid to reduce any sudden large load/generation imbalance and maintain a state of frequency equilibrium for the system's 60Hz (cycles per second) during regular and irregular grid conditions. Large and rapid changes in the electrical load of a system can damage the generator and customers' electrical equipment [62].
- *Black-Start*: This refers to units with the capability to start-up on their own in order to energize the transmission system and assist other facilities to start-up and synchronize to the grid.

4.2. Transmission and distribution

- *System Stability*: The ability to maintain all system components on a transmission line in synchronous operation with each other to prevent a system collapse [62].
- *Grid Angular Stability*: Grid Angular Stability means reducing power oscillations (due to rapid events) by injection and absorption of real power.
- *Grid Voltage Support*: Grid Voltage Support means power provided to the electrical distribution grid to maintain voltages within the acceptable range between each end of all power lines. This involves a trade-off between the amount of "real" energy produced by generators and the amount of "reactive" power produced [68].
- *Asset Deferral*: Defer the need for additional transmission facilities by supplementing and existing transmission facilities—saving capital that otherwise goes underutilized for years [69].

4.3. Energy service

- *Energy Management (Load Levelling / Peak Shaving)*: Load Levelling is rescheduling certain loads to cut electrical power demand, or the production of energy during off-peak periods for storage and use during peak demand periods. Whilst Peak Shaving is reducing electric usage during peak periods or moving usage from the time of peak demand to off-peak periods. This strategy allows to customers to peak shave by shifting energy demand from one time of the day to another. This is primarily used to reduce their time-of-use (demand) charges [62].

- *Unbalanced Load Compensation:* This can be done in combination with four-wire inverters and also by injecting and absorbing power individually at each phase to supply unbalanced loads.
- *Power Quality improvement:* Power Quality is basically related to the changes in magnitude and shape of voltage and current. This result in different issues including: Harmonics, Power Factor, Transients, Flicker, Sag and Swell, Spikes, etc. Distributed energy storage systems (DESS) can mitigate these problems and provide electrical service to the customer without any secondary oscillations or disruptions to the electricity "waveform" [67].
- *Power Reliability:* Can be presented as the percentage/ratio of interruption in delivery of electric power (may include exceeding the threshold and not only complete loss of power) versus total uptime. DESS can help provide reliable electric service to consumers (UPS) to 'ride-through' a power disruption. Coupled with energy management storage, this allows remote power operation [68].

4.4. Supporting the integration of intermittent renewable energy sources

The development and use of renewable energy has experienced rapid growth over the past few years. In the next 20–30 years all sustainable energy systems will have to be based on the rational use of traditional resources and greater use of renewable energy.

Decentralized electrical production from renewable energy sources yields a more assured supply for consumers with fewer environmental hazards. However, the unpredictable character of these sources requires that network provisioning and usage regulations be established for optimal system operation.

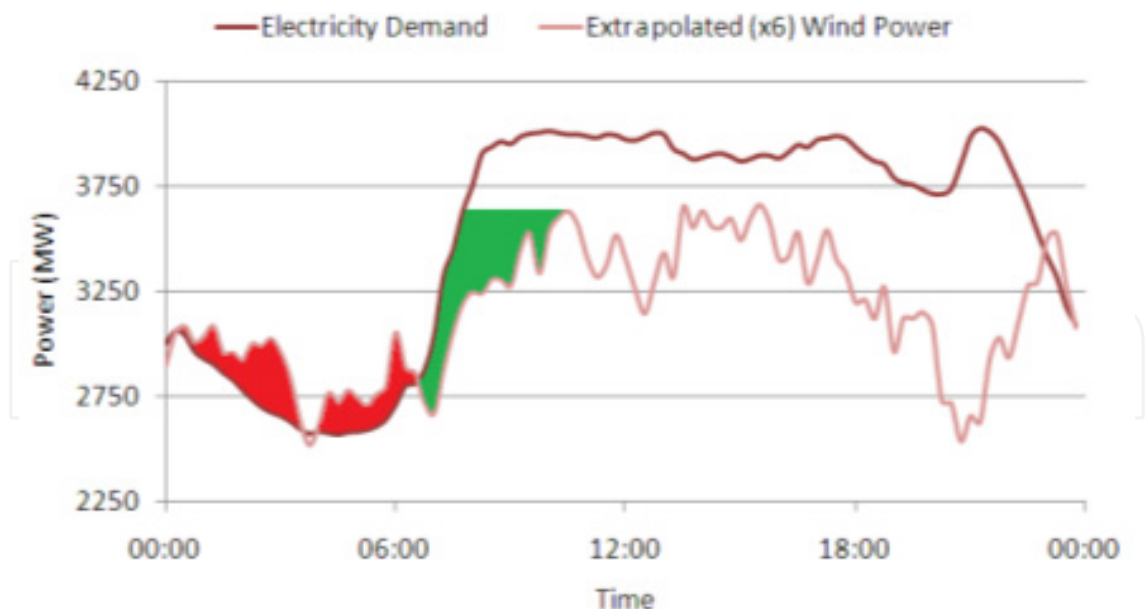

Figure 5. Integration of extrapolated (x6) wind power using energy storage on the Irish electricity grid [58]

However, renewable energy resources have two problems. First, many of the potential power generation sites are located far from load centers. Although wind energy generation facilities can be constructed in less than one year, new transmission facilities must be

constructed to bring this new power source to market. Since it can take upwards of 7 years to build these transmission assets, long, lag-time periods can emerge where wind generation is "constrained-off" the system [62]. For many sites this may preclude them from delivering power to existing customers, but it opens the door to powering off-grid markets—an important and growing market.

The second problem is that the renewable resources fluctuate independently from demand. Therefore, the most of the power accessible to the grids is generated when there is low demand for it. By storing the power from renewable sources from off-peak and releasing it during on-peak, energy storage can transform this low value, unscheduled power into schedulable, high-value product (see Figure 5). Beyond energy sales, with the assured capability of dispatching power into the market, a renewable energy source could also sell capacity into the market through contingency services.

This capability will make the development of renewable resources far more cost-effective — by increasing the value of renewables it may reduce the level of subsidy down to where it is equal to the environmental value of the renewable, at which point it is no longer a subsidy but an environmental credit [62].

- *Frequency and synchronous spinning reserve support:* In grids with a significant share of wind generation, intermittency and variability in wind generation output due to sudden shifts in wind patterns can lead to significant imbalances between generation and load that in turn result in shifts in grid frequency [68]. Such imbalances are usually handled by spinning reserve at the transmission level, but energy storage can provide prompt response to such imbalances without the emissions related to most conventional solutions.
- *Transmission Curtailment Reduction:* Wind power generation is often located in remote areas that are poorly served by transmission and distribution systems. As a result, sometimes wind operators are asked to curtail their production, which results in lost energy production opportunity, or system operators are required to invest in expanding the transmission capability. An EES unit located close to the wind generation can allow the excess energy to be stored and then delivered at times when the transmission system is not congested [68].
- *Time Shifting:* Wind turbines are considered as non-dispatchable resources. EES can be used to store energy generated during periods of low demand and deliver it during periods of high demand (Figure 5). When applied to wind generation, this application is sometimes called "firming and shaping" because it changes the power profile of the wind to allow greater control over dispatch [68].
- *Forecast Hedge:* Mitigation of errors (shortfalls) in wind energy bids into the market prior to required delivery, thus reducing volatility of spot prices and mitigating risk exposure of consumers to this volatility [69].
- *Fluctuation suppression:* Wind farm generation frequency can be stabilised by suppressing fluctuations (absorbing and discharging energy during short duration variations in output) [69].

5. Financial benefits of energy storage systems

In [70] detailed analysis of energy storage benefits is done including market analysis, the following are some highlights:

1. *Cost Reduction or Revenue Increase of Bulk Energy Arbitrage:* Arbitrage involves purchase of inexpensive electricity available during low demand periods to charge the storage plant, so that the low priced energy can be used or sold at a later time when the price for electricity is high [11].
2. *Cost Avoid or Revenue Increase of Central Generation Capacity:* For areas where the supply of electric generation capacity is tight, energy storage could be used to offset the need to: a) purchase and install new generation and/or b) “rent” generation capacity in the wholesale electricity marketplace.
3. *Cost Avoid or Revenue Increase of Ancillary Services:* It is well known that energy storage can provide several types of ancillary services. In short, these are what might be called support services used to keep the regional grid operating. Two more familiar ones are spinning reserve and load following [11].
4. *Cost Avoid or Revenue Increase for Transmission Access/Congestion:* It is possible that use of energy storage could improve the performance of the Transmission and Distribution (T&D) system by giving the utilities the ability to increase energy transfer and stabilize voltage levels. Further, transmission access/congestion charges can be avoided because the energy storage is used.
5. *Reduced Demand Charges:* Reduced demand charges are possible when energy storage is used to reduce an electricity end-user’s use of the electric grid during times grid is high (i.e., during peak electric demand periods) [11].
6. *Reduced Reliability-related Financial Losses:* Storage reduces financial losses associated with power outages. This benefit is very end-user-specific and applies to commercial and industrial (C&I) customers, primarily those for which power outages cause moderate to significant losses.
7. *Reduced Power Quality-related Financial Losses:* Energy storage reduces financial losses associated with power quality anomalies. Power quality anomalies of interest are those that cause loads to go off-line and/or that damage electricity-using equipment and whose negative effects can be avoided if storage is used [11].
8. *Increased Revenue from Renewable Energy Sources:* Storage could be used to time-shift electric energy generated by renewables. Energy is stored when demand and price for power are low, so the energy can be used when a) demand and price for power is high and b) output from the intermittent renewable generation is low.

The previous listed functionalities point out that those energy storages in combination with power electronics will have a huge impact in future electrical supply systems. This is why any planning and implementation strategy should be related to the real-time control and operational functionalities of the ESS in combination with Distributed Energy Resources (DER) in order to get rapid integration process.

6. Techno-economic characteristics of energy storage systems

The main characteristics of storage systems on which the selection criteria are based are the following [73]:

6.1. Storage capacity

This is the quantity of available energy in the storage system after charging. Discharge is often incomplete. For this reason, it is defined on the basis of total energy stored, which is superior to that actually retrieved (operational). The usable energy, limited by the depth of discharge, represents the limit of discharge depth (minimum-charge state). In conditions of quick charge or discharge, the efficiency deteriorates and the retrievable energy can be much lower than storage capacity (Figure 6). On the other hand, self-discharge is the attenuating factor under very slow regime.

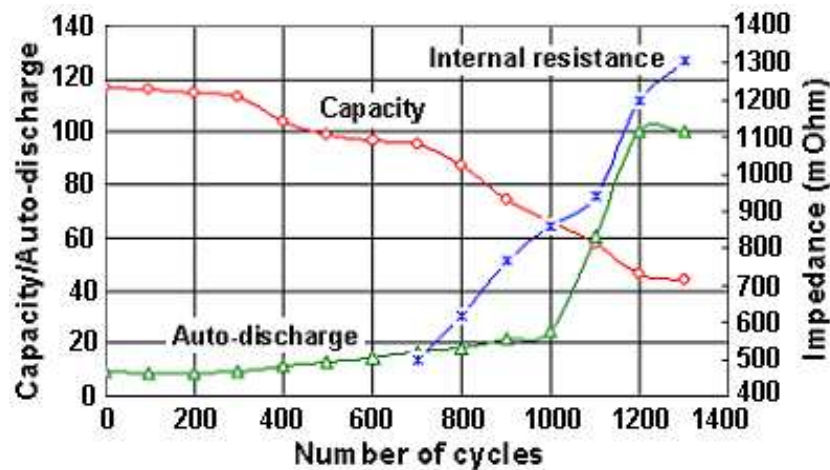

Figure 6. Variation of energy capacity, self-discharge and internal resistance of a nickel-metal-hydride battery with the number of cycles [71]

6.2. Storage System Power

This parameter determines the constitution and size of the motor-generator in the stored energy conversion chain. A storage system's power rating is assumed to be the system's nameplate power rating under normal operating conditions [73]. Furthermore, that rating is assumed to represent the storage system's *maximum* power output under *normal* operating conditions. In this document, the normal discharge rate used is commonly referred to as the system's 'design' or 'nominal' (power) rating.

6.3. Storage 'Emergency' Power Capability

Some types of storage systems can discharge at a relatively high rate (*e.g.*, 1.5 to 2 times their nominal rating) for relatively short periods of time (*e.g.*, several minutes to as much as 30 minutes). One example is storage systems involving a Na/S battery, which is capable of producing two times its rated (normal) output for relatively short durations [72].

That feature – often referred to as the equipment’s ‘emergency’ rating – is valuable if there are circumstances that occur infrequently that involve an urgent need for relatively high power output, for relatively short durations.

Importantly, while discharging at the higher rate, storage efficiency is reduced (relative to efficiency during discharge at the nominal discharge rate), and storage equipment damage increases (compared to damage incurred at the normal discharge rate).

So, in simple terms, storage with emergency power capability could be used to provide the nominal amount of power required to serve a regularly occurring need (*e.g.*, peak demand reduction) while the same storage could provide additional power for urgent needs that occur infrequently and that last for a few to several minutes at a time [72].

6.4. Autonomy

Autonomy or discharge duration autonomy is the amount of time that storage can discharge at its rated output (power) without recharging. Discharge duration is an important criterion affecting the technical viability of a given storage system for a given application and storage plant cost [73]. This parameter depends on the depth of discharge and operational conditions of the system, constant power or not. It is a characteristic of system adequacy for certain applications. For small systems in an isolated area relying on intermittent renewable energy, autonomy is a crucial criterion. The difficulty in separating the power and energy dimensions of the system makes it difficult to choose an optimum time constant for most storage technologies [74].

6.5. Energy and power density

Power density is the amount of power that can be delivered from a storage system with a given volume or mass. Similarly, energy density is the amount of energy that can be stored in a storage device that has a given volume or mass. These criteria are important in situations for which space is valuable or limited and/or if weight is important (especially for mass density of energy in portable applications, but less so for permanent applications).

6.6. Space requirements for energy storage

Closely related to energy and power density are footprint and space requirements for energy storage. Depending on the storage technology, floor area and/or space constraints may indeed be a challenge, especially in heavily urbanized areas.

6.7. Efficiency

All energy transfer and conversion processes have losses. Energy storage is no different. Storage system round-trip efficiency (efficiency) reflects the amount of energy that comes out of storage relative to the amount put into the storage. This definition is often oversimplified because it is based on a single operation point [75]. The definition of

efficiency must therefore be based on one or more realistic cycles for a specific application. Instantaneous power is a defining factor of efficiency (Figure 7). This means that, for optimum operation, the power-transfer chain must have limited losses in terms of energy transfer and self-discharge. This energy conservation measure is an essential element for daily network load-levelling applications.

Typical values for efficiency include the following: 60% to 75% for conventional electrochemical batteries; 75% to 85% for advanced electrochemical batteries; 73% to 80% for CAES; 75% to 78% for pumped hydro; 80% to 90% for flywheel storage; and 95% for capacitors and SMES [72], [76].

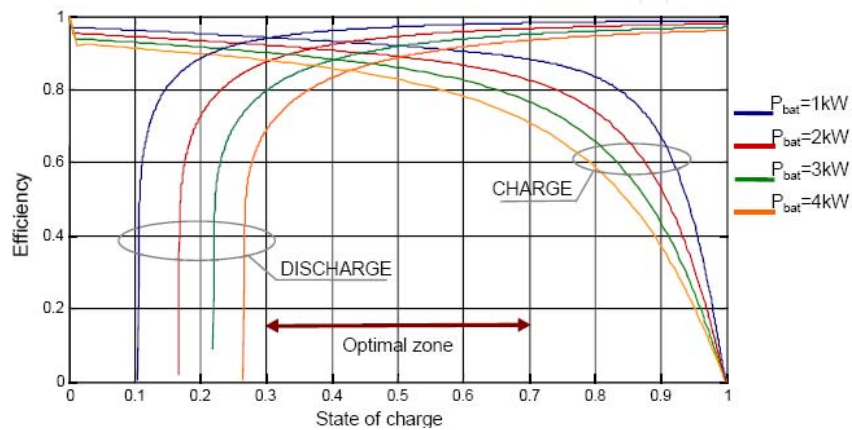

Figure 7. Power efficiency of a 48V-310Ah (15 kWh/10 h discharge) lead accumulator [77]

6.8. Storage operating cost

Storage total operating cost (as distinct from plant *capital* cost or plant financial carrying charges) consists of two key components: 1) energy-related costs and 2) operating costs not related to energy. Non-energy operating costs include at least four elements: 1) labor associated with plant operation, 2) plant maintenance, 3) equipment wear leading to loss-of-life, and 4) decommissioning and disposal cost [73].

1. *Charging Energy-Related Costs:* The energy cost for storage consists of all costs incurred to purchase energy used to charge the storage, including the cost to purchase energy needed to make up for (round trip) energy losses [73]. For a storage system with 75% efficiency, if the unit price for energy used for charging is 4¢/kWh, then the plant energy cost is 5.33¢/kWh.
2. *Labor for Plant Operation:* In some cases, labor may be required for storage plant operation. Fixed labor costs are the same magnitude irrespective of how much the storage is used. Variable labor costs are proportional to the frequency and duration of storage use [73]. In many cases, labor is required to operate larger storage facilities and/or 'blocks' of aggregated storage capacity whereas little or no labor may be needed for smaller/distributed systems that tend to be designed for autonomous operation. No explicit value is ascribed to this criterion, due in part to the wide range of labor costs that are possible given the spectrum of storage types and storage system sizes [73].

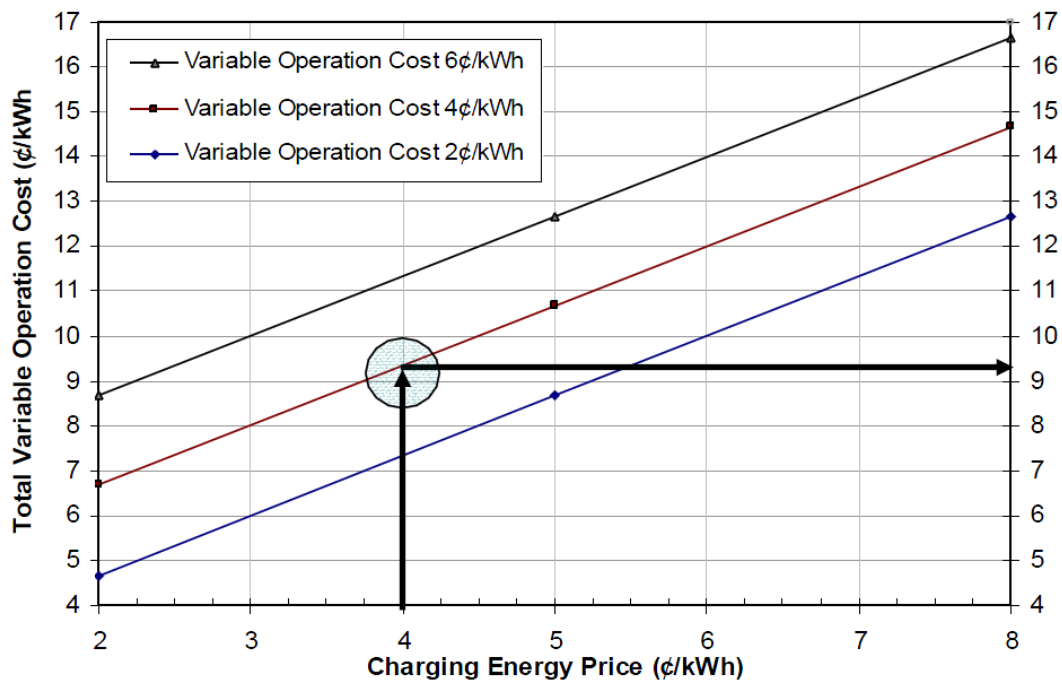

Figure 8. Storage total variable operation cost for 75% storage efficiency [73]

3. *Plant Maintenance:* Plant maintenance costs are incurred to undertake normal, scheduled, and unplanned repairs and replacements for equipment, buildings, grounds, and infrastructure. Fixed maintenance costs are the same magnitude irrespective of how much the storage is used [73]. Variable maintenance costs are proportional to the frequency and duration of storage use.
4. *Replacement Cost:* If specific equipment or subsystems within a storage system are expected to wear out during the expected life of the system, then a ‘replacement cost’ will be incurred. In such circumstances, a ‘sinking fund’ is needed to accumulate funds to pay for replacements when needed [73]. That replacement cost is treated as a variable cost (i.e., the total cost is spread out over each unit of energy output from the storage plant).
5. *Variable Operating Cost:* A storage system’s total variable operating cost consists of applicable non-energy-related variable operating costs plus plant energy cost, possibly including charging energy, labor for plant operation, variable maintenance, and replacement costs. Variable operating cost is a key factor affecting the cost-effectiveness of storage [73]. It is especially important for ‘high-use’ value propositions involving many charge-discharge cycles.

Ideally, storage for high-use applications should have relatively high or very high efficiency and relatively low variable operating cost. Otherwise, the total cost to charge then discharge the storage is somewhat-to-very likely to be higher than the benefit. That can be a significant challenge for some storage types and value propositions.

Consider the example illustrated in Figure 8, which involves a 75% efficient storage system with a non-energy-related variable operating cost of 4¢/kWh. If that storage system is

charged with energy costing 4¢/kWhin, then the total variable operating cost – for energy output – is about 9.33¢/kWhout [73].

6.9. Durability

Lifetime or durability refers to the number of times the storage unit can release the energy level it was designed for after each recharge, expressed as the maximum number of cycles N (one cycle corresponds to one charge and one discharge) [81]. All storage systems degrade with use because they are subject to fatigue or wear by usage use (i.e., during each charge-discharge cycle). This is usually the principal cause of aging, ahead of thermal degradation. The rate of degradation depends on the type of storage technology, operating conditions, and other variables. This is especially important for electrochemical batteries [73].

For some storage technologies – especially batteries – the extent to which the system is emptied (discharged) also affects the storage media's useful life. Discharging a small portion of stored energy is a 'shallow' discharge and discharging most or all of the stored energy is a 'deep' discharge. For these technologies, a shallow discharge is less damaging to the storage medium than a deep discharge [73].

To the extent that the storage medium degrades and must be replaced during the expected useful life of the storage system, the cost for that replacement must be added to the variable operating cost of the storage system.

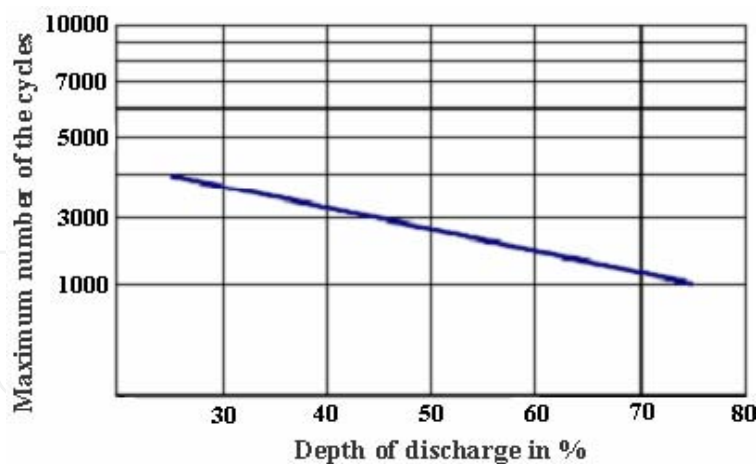

Figure 9. Evolution of cycling capacity as a function of depth of discharge for a lead-acid battery [79]

The design of a storage system that considers the endurance of the unit in terms of cycles should be a primary importance when choosing a system. However, real fatigue processes are often complex and the cycling capacity is not always well defined. In all cases, it is strongly linked to the amplitude of the cycles (Figure 9) and/or the average state of charge [78]. As well, the cycles generally vary greatly, meaning that the quantification of N is delicate and the values given represent orders of magnitude [74].

6.10. Reliability

Like power rating and discharge duration, storage system reliability requirements are circumstance-specific. Little guidance is possible. Storage-system reliability is always an important factor because it is a guarantee of on-demand service [81]. The project design engineer is responsible for designing a plant that provides enough power and that is as reliable as necessary to serve the specific application.

6.11. Response time

Storage response time is the amount of time required to go from no discharge to full discharge. At one extreme, under almost all conditions, storage has to respond quite rapidly if used to provide capacity on the margin *in lieu* of transmission and distribution (T&D) capacity. That is because the output from T&D equipment (*i.e.*, wires and transformers) changes nearly instantaneously in response to demand [73].

In contrast, consider storage used *in lieu* of generation capacity. That storage does not need to respond as quickly because generation tends to respond relatively slowly to demand changes. Specifically, some types of generation – such as engines and combustion turbines – take several seconds to many minutes before generating at full output. For other generation types, such as those fueled by coal and nuclear energy, the response time may be hours [73].

Most types of storage have a response time of several seconds or less. CAES and pumped hydroelectric storage tend to have a slower response, though they still respond quickly enough to serve several important applications.

6.12. Ramp rate

An important storage system characteristic for some applications is the ramp rate – the rate at which power output can change. Generally, storage ramp rates are rapid (*i.e.*, output can change quite rapidly); pumped hydro is the exception. Power devices with a slow response time tend also to have a slow ramp rate [73].

6.13. Charge rate

Charge rate – the rate at which storage can be charged – is an important criterion because, often, modular energy storage (MES) must be recharged so it can serve load during the next day [58]. If storage cannot recharge quickly enough, then it will not have enough energy to provide the necessary service. In most cases, storage charges at a rate that is similar to the rate at which it discharges [73]. In some cases, storage may charge more rapidly or more slowly, depending on the capacity of the power conditioning equipment and the condition and/or chemistry and/or physics of the energy storage medium.

6.14. Self-discharge and energy retention

Energy retention time is the amount of time that storage retains its charge. The concept of energy retention is important because of the tendency for some types of storage to self-discharge or to otherwise dissipate energy while the storage is not in use. In general terms, energy losses could be referred to as *standby* losses [74].

Storage that depends on chemical media is prone to self-discharge. This self-discharge is due to chemical reactions that occur while the energy is stored. Each type of chemistry is different, both in terms of the chemical reactions involved and the rate of self-discharge. Storage that uses mechanical means to store energy tends to be prone to energy dissipation. For example, energy stored using pumped hydroelectric storage may be lost to evaporation. CAES may lose energy due to air escaping from the reservoir [73].

To the extent that storage is prone to self-discharge or energy dissipation, retention time is reduced. This characteristic tends to be less important for storage that is used frequently. For storage that is used infrequently (i.e., is in standby mode for a significant amount of time between uses), this criterion may be very important [72].

6.15. Transportability

Transportability can be an especially valuable feature of storage systems for at least two reasons. First, transportable storage can be (re)located where it is needed most and/or where benefits are most significant [58]. Second, some locational benefits only last for one or two years. Given those considerations, transportability may significantly enhance the prospects that lifecycle benefits will exceed lifecycle cost.

6.16. Power conditioning

To one extent or another, most storage types require some type of power conditioning (i.e., conversion) subsystem. Equipment used for power conditioning – the power conditioning unit (PCU) – modifies electricity so that the electricity has the necessary voltage and the necessary form; either alternating current (AC) or direct current (DC). The PCU, in concert with an included control system, must also synchronize storage output with the oscillations of AC power from the grid [73].

Output from storage with relatively low-voltage DC output must be converted to AC with higher voltage before being discharged into the grid and/or before being used by most load types. In most cases, conversion from DC to AC is accomplished using a device known as an *inverter* [73].

For storage requiring DC input, the electricity used for charging must be converted from the form available from the grid (i.e., AC at relatively high voltage) to the form needed by the storage system (e.g., DC at lower voltage). That is often accomplished via a PCU that can function as a DC 'power supply' [73].

6.17. Power quality

Although requirements for applications vary, the following storage characteristics may or may not be important. To one extent or another, they are affected by the PCU used and/or they drive the specifications for the PCU. In general, higher quality power (output) costs more.

6. *Power Factor*: Although detailed coverage of the concept of power factor is beyond the scope of this report, it is important to be aware of the importance of this criterion. At a minimum, the power output from storage should have an acceptable power factor, where acceptable is somewhat circumstance variable power factor.
7. *Voltage Stability*: In most cases, it is important for storage output voltage to remain somewhat-to-very constant. Depending on the circumstances, voltage can vary; though, it should probably remain within about 5% to 8% of the rated value.
8. *Waveform*: Assuming that storage output is AC, in most cases, the waveform should be as close as possible to that of a sine wave. In general, higher quality PCUs tend to have waveforms that are quite close to that of a sine wave whereas output from lower quality PCUs tends to have a waveform that is somewhat square.
9. *Harmonics*: Harmonic currents in distribution equipment can pose a significant challenge. Harmonic currents are components of a periodic wave whose frequency is an integral multiple of the fundamental frequency [73]. In this case, the fundamental frequency is the utility power line frequency of 60 Hz.

6.18. Modularity

One attractive feature of modular energy storage is the flexibility that system ‘building blocks’ provide. Modularity allows for more optimal levels and types of capacity and/or discharge duration because modular resources allow utilities to increase or decrease storage capacity, when and where needed, in response to changing conditions [72-73]. Among other attractive effects, modular capacity provides attractive means for utilities to address uncertainty and to manage risk associated with large, ‘lumpy’ utility T&D investments.

6.19. Storage system reactive power capability

One application (Voltage Support) and one incidental benefit (Power Factor Correction) described in this guide involve storage whose capabilities include absorbing and injecting reactive power (expressed in units of volt-Amperes reactive or VARs) [58], [72-73]. This feature is commonly referred as VAR support. In most cases, storage systems by themselves do not have reactive power capability. For a relatively modest incremental cost, however, reactive power capability can be added to most storage system types.

6.20. Feasibility and adaptation to the generating source

To be highly efficient, a storage system needs to be closely adapted to the type of application (low to mid power in isolated areas, network connection, etc.) and to the type of production

(permanent, portable, renewable, etc.) (Figure 10) it is meant to support. It needs to be harmonized with the network.

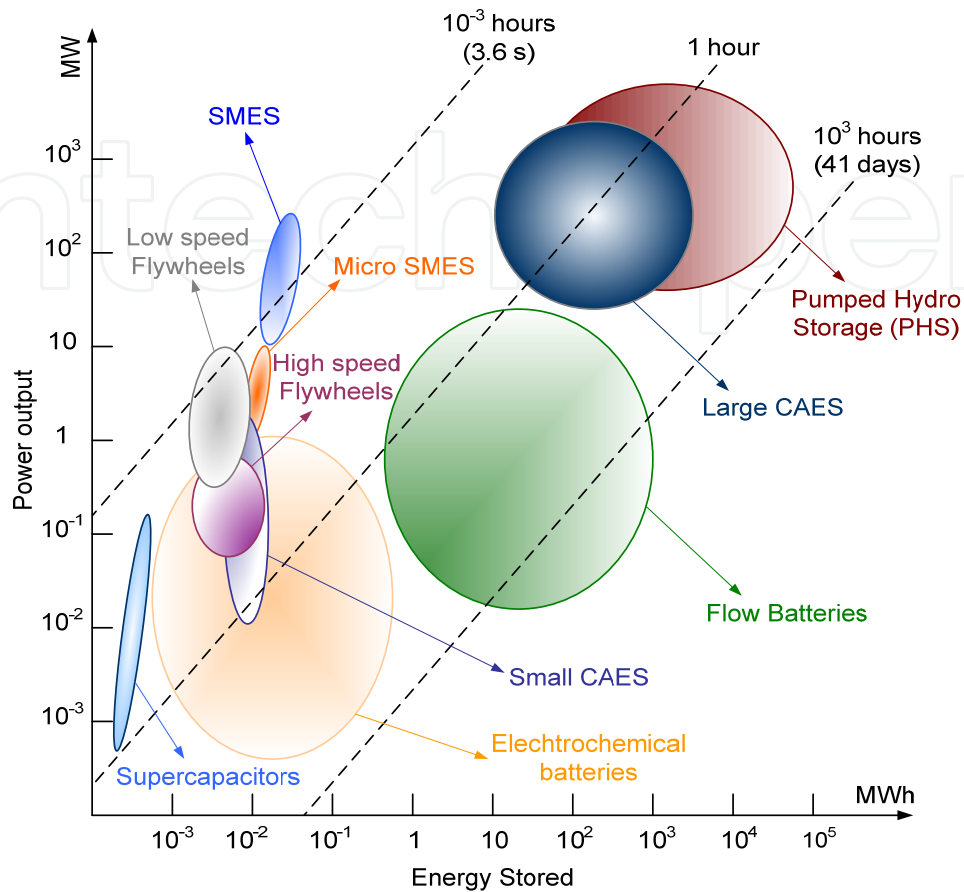

Figure 10. Fields of application of the different storage techniques according to stored energy and power output [80]

6.21. Monitoring, control and communications equipments

This equipment, on both the quality and safety of storage levels, has repercussions on the accessibility and availability of the stored energy [74]. Indeed, storage used for most applications addressed in this report must receive and respond to appropriate control signals. In some cases, storage may have to respond to a dispatch control signal. In other cases, the signal may be driven by a price or prices [73]. Storage response to a control signal may be a simple ramp up or ramp down of power output in proportion to the control signal. A more sophisticated response, requiring one or more control algorithms, may be needed.

6.22. Interconnection

If storage will be charged with energy from the grid or will inject energy into the grid, it must meet applicable interconnection requirements. At the distribution level, an important point of reference is the Institute of Electronics and Electrical Engineers (IEEE) Standard 1547 [82]. Some countries and utilities have more specific interconnection rules and requirements.

6.23. Operational constraints

Especially related to safety (explosions, waste, bursting of a flywheel, etc.) or other operational conditions (temperature, pressure, etc.), they can influence the choice of a storage technology as a function of energy needs [74].

6.24. Environmental aspect

While this parameter is not a criterium of storage-system capacity, the environmental aspect of the product (recyclable materials) is a strong sales pitch. For example, in Nordic countries (Sweden, Norway), a definite margin of the population prefers to pay more for energy than to continue polluting the country [83]. This is a dimension that must not, therefore, be overlooked.

6.25. Decommissioning and disposal needs and cost

In most cases there will be non-trivial decommissioning costs associated with almost any storage system [73]. For example, eventually batteries must be dismantled and the chemicals must be removed. Ideally, dismantled batteries and their chemicals can be recycled, as is the case for the materials in lead-acid batteries.

Ultimately, decommissioning-related costs should be included in the total cost to own and to operate storage.

6.26. Other characteristics

The ease of maintenance, simple design, operational flexibility (this is an important characteristic for the utility), fast response time for the release of stored energy, etc.

Finally, it is important to note that these characteristics apply to the overall storage system: storage units and power converters alike [74].

7. Classification of energy storage systems

There are two criteria to categorise the various ESSs: function and form. In terms of the function, ESS technologies can be categorised into those that are intended firstly for high power ratings with a relatively small energy content making them suitable for power quality or UPS [69]; and those designed for energy management, as shown in Figure 11. PHS, CAES, TES, large-scale batteries, flow batteries, fuel cells, solar fuel and TES fall into the category of energy management, whereas capacitors/super-capacitors, SMES, flywheels and batteries are in the category of power quality and reliability. This simple classification glosses over the wide range of technical parameters of energy storage devices.

Although electricity is not easy to be directly stored cheaply, it can be easily stored in other forms and converted back to electricity when needed. Storage technologies for electricity can also be classified by the form of storage into the following [69]:

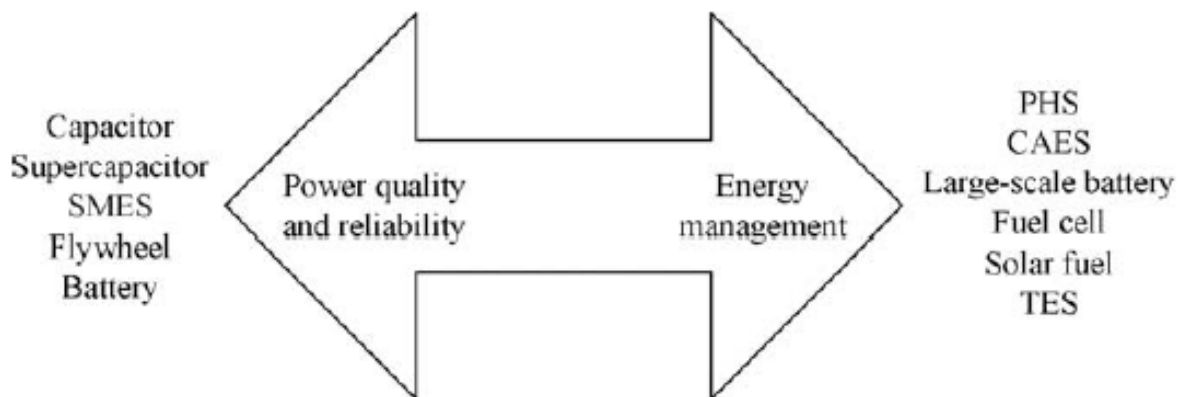

Figure 11. Energy storage classification with respect to function [69].

1. *Electrical energy storage:* (i) Electrostatic energy storage including capacitors and supercapacitors; (ii) Magnetic/current energy storage including SMES.
2. *Mechanical energy storage:* (i) Kinetic energy storage (flywheels); (ii) Potential energy storage (PHES and CAES).
3. *Chemical energy storage:* (i) electrochemical energy storage (conventional batteries such as lead-acid, nickel metal hydride, lithium ion and flow-cell batteries such as zinc bromine and vanadium redox); (ii) chemical energy storage (fuel cells, Molten-Carbonate Fuel Cells – MCFCs and Metal-Air batteries); (iii) thermochemical energy storage (solar hydrogen, solar metal, solar ammonia dissociation–recombination and solar methane dissociation–recombination).
4. *Thermal energy storage:* (i) Low temperature energy storage (Aquiferous cold energy storage, cryogenic energy storage); (ii) High temperature energy storage (sensible heat systems such as steam or hot water accumulators, graphite, hot rocks and concrete, latent heat systems such as phase change materials).

8. Description of energy storage technologies

8.1. Pumped hydro storage (PHS)

In pumping hydro storage, a body of water at a relatively high elevation represents a potential or stored energy. During peak hours the water in the upper reservoir is lead through a pipe downhill into a hydroelectric generator and stored in the lower reservoir. Along off-peak periods the water is pumped back up to recharge the upper reservoir and the power plant acts like a load in power system [72], [84].

Pumping hydro energy storage system (figure 12) consists in two large water reservoirs, electric machine (motor/generator) and reversible pump-turbine group or pump and turbine separated. This system can be started-up in few minutes and its autonomy depends on the volume of stored water.

Restrictions to pumping hydro energy storage are related with geographical constraints and weather conditions. In periods of much rain, pumping hydro capacity can be reduced.

Pumped hydroelectric systems have conversion efficiency, from the point of view of a power network, of about 65–80%, depending on equipment characteristics [72]. Considering the cycle efficiency, 4 kWh are needed to generate three. The storage capacity depends on two parameters: the height of the waterfall and the volume of water. A mass of 1 ton falling 100 m generates 0.272 kWh.

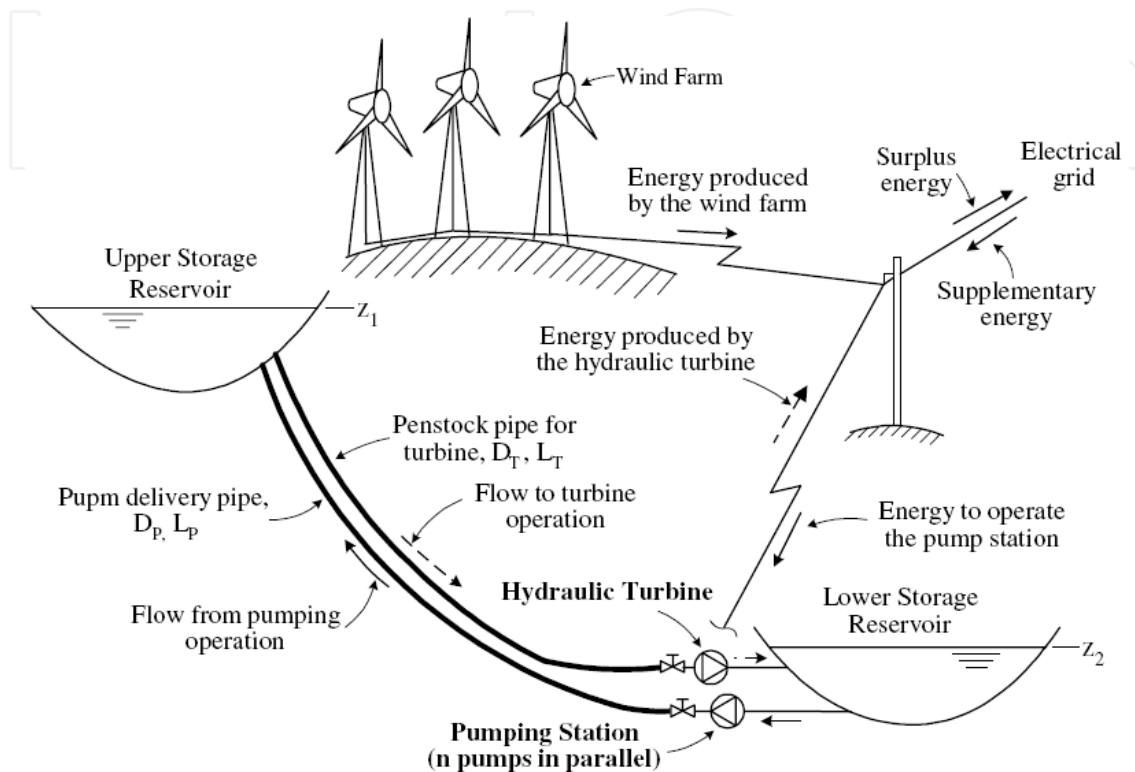

Figure 12. Wind-Pumped hydro energy storage hybrid system [69].

8.2. Batteries energy storage

Batteries store energy in electrochemical form creating electrically charged ions. When the battery charges, a direct current is converted in chemical energy, when discharges, the chemical energy is converted back into a flow of electrons in direct current form [75]. Electrochemical batteries use electrodes both as part of the electron transfer process and store the products or reactants via electrode solid-state reactions [85]. Batteries are the most popular energy storage devices. However, the term battery comprises a sort of several technologies applying different operation principals and materials. There is a wide range of technologies used in the fabrication of electrochemical accumulators (lead–acid (Figure 13), nickel–cadmium, nickel–metal hydride, nickel–iron, zinc–air, iron–air, sodium–sulphur, lithium–ion, lithium–polymer, etc.) and their main assets are their energy densities (up to 150 and 2000 Wh/kg for lithium) and technological maturity. Their main inconvenient however is their relatively low durability for large-amplitude cycling (a few 100 to a few 1000 cycles). They are often used in portable systems, but also in permanent applications (emergency network back-up, renewable-energy storage in isolated areas, etc.) [83].

The minimum discharge period of the electrochemical accumulators rarely reaches below 15 minutes. However, for some applications, power up to 100 W/kg, even a few kW/kg, can be reached within a few seconds or minutes. As opposed to capacitors, their voltage remains stable as a function of charge level. Nevertheless, between a high-power recharging operation at near-maximum charge level and its opposite, that is to say a power discharge nearing full discharge, voltage can easily vary by a ratio of two [74].

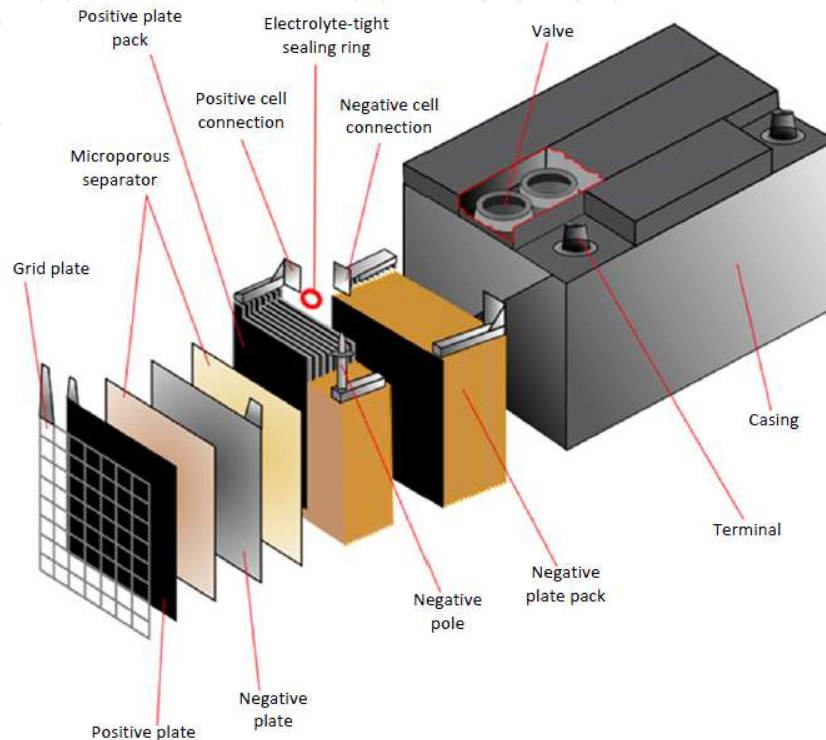

Figure 13. Structure of a lead-acid battery [86]

8.3. Flow batteries energy storage (FBES)

Flow batteries are a two-electrolyte system in which the chemical compounds used for energy storage are in liquid state, in solution with the electrolyte. They overcome the limitations of standard electrochemical accumulators (lead-acid or nickel-cadmium for example) in which the electrochemical reactions create solid compounds that are stored directly on the electrodes on which they form. This is therefore a limited-mass system, which obviously limits the capacity of standard batteries.

Various types of electrolyte have been developed using bromine as a central element: with zinc (ZnBr), sodium (NaBr) (Figure 14), vanadium (VBr) and, more recently, sodium polysulfide. The electrochemical reaction through a membrane in the cell can be reversed (charge-discharge). By using large reservoirs and coupling a large number of cells, large quantities of energy can be stored and then released by pumping electrolyte into the reservoirs.

The main advantages of the technology include the following [87]: 1) high power and energy capacity; 2) fast recharge by replacing exhaust electrolyte; 3) long life enabled by

easy electrolyte replacement; 4) full discharge capability; 5) use of nontoxic materials; and 6) low-temperature operation. The main disadvantage of the system is the need for moving mechanical parts such as pumping systems that make system miniaturization difficult. Therefore, the commercial uptake to date has been limited. The best example of flow battery was developed in 2003 by Regenesys Technologies, England, with a storage capacity of 15 MW-120 MWh. It has since been upgraded to an electrochemical system based entirely on vanadium. The overall electricity storage efficiency is about 75 % [88].

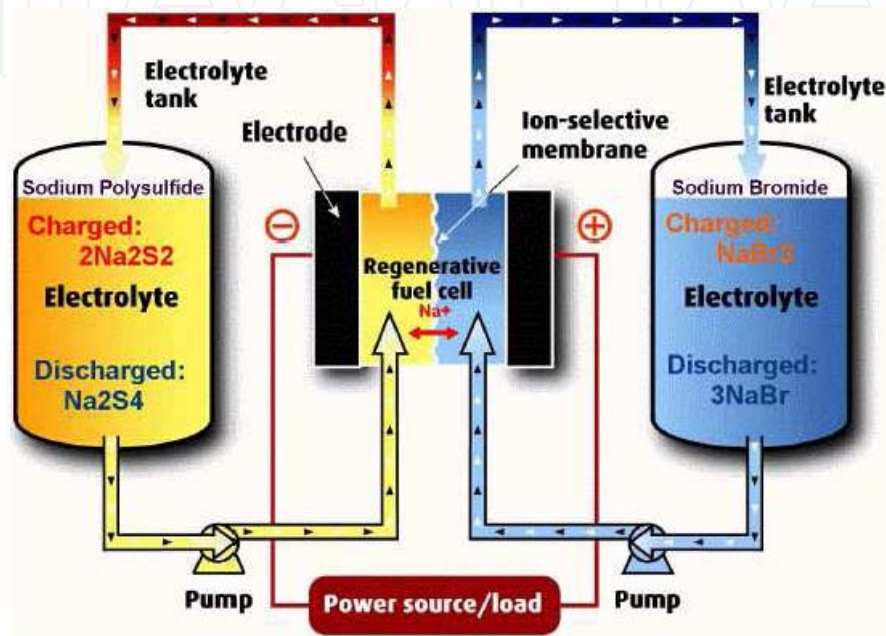

Figure 14. Illustration of a flow-battery

8.4. Flywheel energy storage (FES)

Flywheel energy accumulators are comprised of a massive or composite flywheel coupled with a motor-generator and special brackets (often magnetic), set inside a housing at very low pressure to reduce self-discharge losses (Figure 15) [9]. They have a great cycling capacity (a few 10,000 to a few 100,000 cycles) determined by fatigue design.

To store energy in an electrical power system, high-capacity flywheels are needed. Friction losses of a 200 tons flywheel are estimated at about 200 kW. Using this hypothesis and instantaneous efficiency of 85 %, the overall efficiency would drop to 78 % after 5 hours, and 45 % after one day. Long-term storage with this type of apparatus is therefore not foreseeable.

From a practical point of view, electromechanical batteries are more useful for the production of energy in isolated areas. Kinetic energy storage could also be used for the distribution of electricity in urban areas through large capacity buffer batteries, comparable to water reservoirs, aiming to maximize the efficiency of the production units. For example, large installations made up of forty 25kW-25kWh systems are capable of storing 1 MW that can be released within one hour.

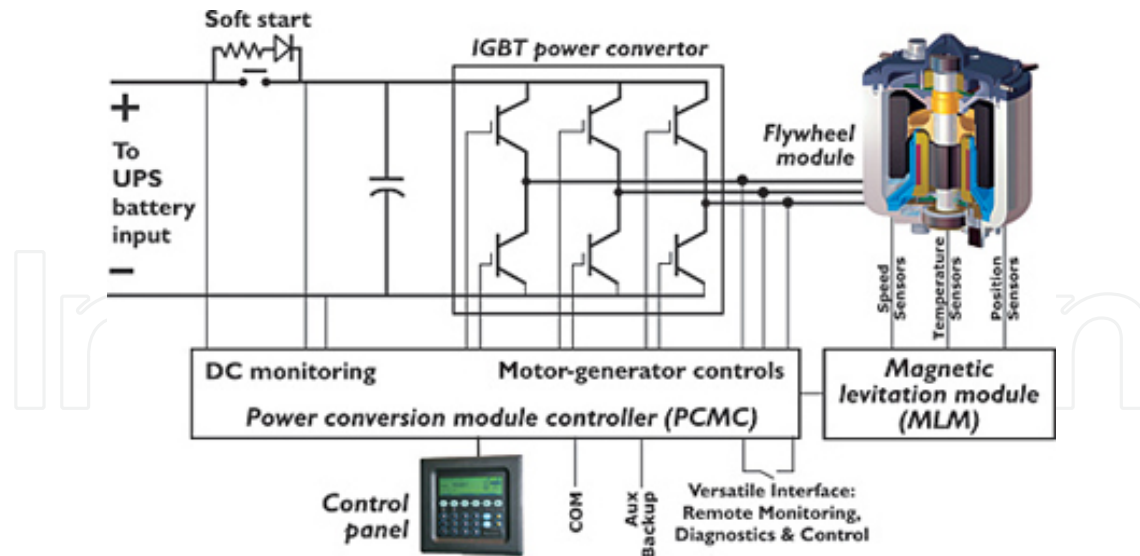

Figure 15. Flywheel energy accumulators [89]

8.5. Supercapacitors energy storage (SES)

Supercapacitors are the latest innovational devices in the field of electrical energy storage. In comparison with a battery or a traditional capacitor, the supercapacitor allows a much powerful power and energy density [15]. Supercapacitors are electrochemical double layer capacitors that store energy as electric charge between two plates, metal or conductive, separated by a dielectric, when a voltage differential is applied across the plates. As like battery systems, capacitors work in direct current.

The energy/volume obtained is superior to that of capacitors (5 Wh/kg or even 15 Wh/kg), at very high cost but with better discharge time constancy due to the slow displacement of ions in the electrolyte (power of 800–2000 W/kg). Super-capacitors generally are very durable, that is to say 8–10 years, 95% efficiency and 5% per day self-discharge, which means that the stored energy must be used quickly.

Supercapacitors find their place in many applications where energy storage is needed, like uninterruptible power supplies, or can help in smoothing strong and short-time power solicitations of weak power networks. Their main advantages are the long life cycle and the short charge/discharge time [2], [19].

8.6. Superconducting magnetic energy storage (SMES)

An emerging technology, systems store energy in the magnetic field created by the flow of direct current in a coil of cryogenically cooled, superconducting material. Due to their construction, they have a high operating cost and are therefore best suited to provide constant, deep discharges and constant activity. The fast response time (under 100 ms) of these systems makes them ideal for regulating network stability (load levelling). Power is available almost instantaneously and very high power output can be provided for a brief period of time [20-21]. These facilities currently range in size up to 3 MW units and are

generally used to provide grid stability in a distribution system and power quality at manufacturing facilities requiring ultra-clean power such a chip fabrication facility.

One advantage of this storage system is its great instantaneous efficiency, near 95 % for a charge-discharge cycle [90]. Moreover, these systems are capable of discharging the near totality of the stored energy, as opposed to batteries. They are very useful for applications requiring continuous operation with a great number of complete charge-discharge cycles.

8.7. Fuel cells-Hydrogen energy storage (HES)

Fuel cells are a means of restoring spent energy to produce hydrogen through water electrolysis. The storage system proposed includes three key components: electrolysis which consumes off-peak electricity to produce hydrogen, the fuel cell which uses that hydrogen and oxygen from air to generate peak-hour electricity, and a hydrogen buffer tank to ensure adequate resources in periods of need.

Fuel cells can be used in decentralized production (particularly low-power stations – residential, emergency...), spontaneous supply related or not to the network, mid-power cogeneration (a few hundred kW), and centralized electricity production without heat upgrading. They can also represent a solution for isolated areas where the installation of power lines is too difficult or expensive (mountain locations, etc.). There are several hydrogen storage modes, such as: compressed, liquefied, metal hydride, etc. For station applications, pressurized tanks with a volume anywhere between 10^{-2} m³ and 10,000 m³ are the simplest solution to date. Currently available commercial cylinders can stand pressures up to 350 bars.

Combining an electrolyser and a fuel cell for electrical energy storage is a low-efficiency solution (at best 70 % for the electrolyser and 50 % for the fuel cell, and 35 % for the combination). As well, the investment costs are prohibitive and life expectancy is very limited, especially for power network applications [74].

8.8. Thermal energy storage (TES)

Thermal energy storage (TES) already exists in a wide spectrum of applications. It uses materials that can be kept at high/low temperatures in insulated containments. Heat/cold recovered can then be applied for electricity generation using heat engine cycles.

Energy input can, in principle, be provided by electrical resistance heating or refrigeration/cryogenic procedures, hence the overall round trip efficiency of TES is low (30–60%) although the heat cycle efficiency could be high (70–90%), but it is benign to the environment and may have particular advantages for renewable and commercial buildings.

TES systems can be classified into low-temperature TES and high-temperature TES depending on whether the operating temperature of the energy storage material is higher

than the room temperature. More precisely, TES can be categorised into industrial cooling (below $-18\text{ }^{\circ}\text{C}$), building cooling (at $0\text{--}12\text{ }^{\circ}\text{C}$), building heating (at $25\text{--}50\text{ }^{\circ}\text{C}$) and industrial heat storage (higher than $175\text{ }^{\circ}\text{C}$).

8.9. Compressed Air Energy Storage (CAES)

This method consist to use off-peak power to pressurize air into an underground reservoir (salt cavern, abandoned hard rock mine or aquifer) which is then released during peak daytime hours to power a turbine/generator for power production. CAES (Figure 16) is the only other commercially available technology (besides pumped-hydro) able to provide the very-large system energy storage deliverability (above 100 MW in single unit sizes) to use for commodity storage or other large-scale setting [74].

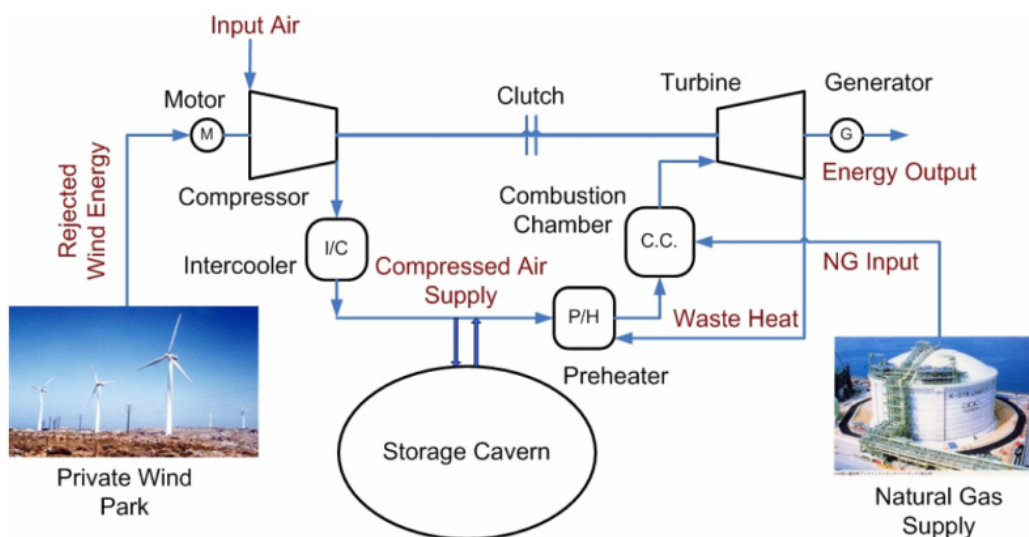

Figure 16. Illustration of compressed-air energy storage

The energy density for this type of system is in the order of 12 kWh/m^3 [91], while the estimated efficiency is around 70 % [92]. Let us note that to release 1 kWh into the network, 0.7–0.8 kWh of electricity needs to be absorbed during off-peak hours to compress the air, as well as 1.22 kWh of natural gas during peak hours (retrieval). Two plants currently exist, with several more under development. The first operating unit is a 290 MW unit built in Huntorf, Germany in 1978. The second plant is a 110 MW unit built in McIntosh, Alabama in 1991. Small-scale compressed air energy storage (SSCAES), compressed air storage under high pressure in cylinders (up to 300 bars with carbon fiber structures) are still developing and seem to be a good solution for small- and medium-scale applications.

9. Assessment and comparison of the energy storage technologies

Following, some figures are presented that compare different aspects of storage technologies. These aspects cover topics such as: technical maturity, range of applications, efficiencies, lifetime, costs, mass and volume densities, etc.

9.1. Technical maturity

The technical maturity of the EES systems is shown in Figure 17. The EES technologies can be classified into three categories in terms of their maturity [69]:

1. Mature technologies: PHS and lead-acid battery are mature and have been used for over 100 years.
2. Developed technologies: CAES, NiCd, NaS, ZEBRA Li-ion, Flow Batteries, SMES, flywheel, capacitor, supercapacitor, AL-TES (Aquiferous low- temperature – Thermal energy storage) and HT-TES (High temperature – Thermal energy storage) are developed technologies. All these EES systems are technically developed and commercially available; however, the actual applications, especially for large-scale utility, are still not widespread. Their competitiveness and reliability still need more trials by the electricity industry and the market.
3. Developing technologies: Fuel cell, Meta-Air battery, Solar Fuel and CES (Cryogenic Energy Storage) are still under development. They are not commercially mature although technically possible and have been investigated by various institutions. On the other hand, these developing technologies have great potential for industrial take up in the near future. Energy costs and environmental concerns are the main drivers.

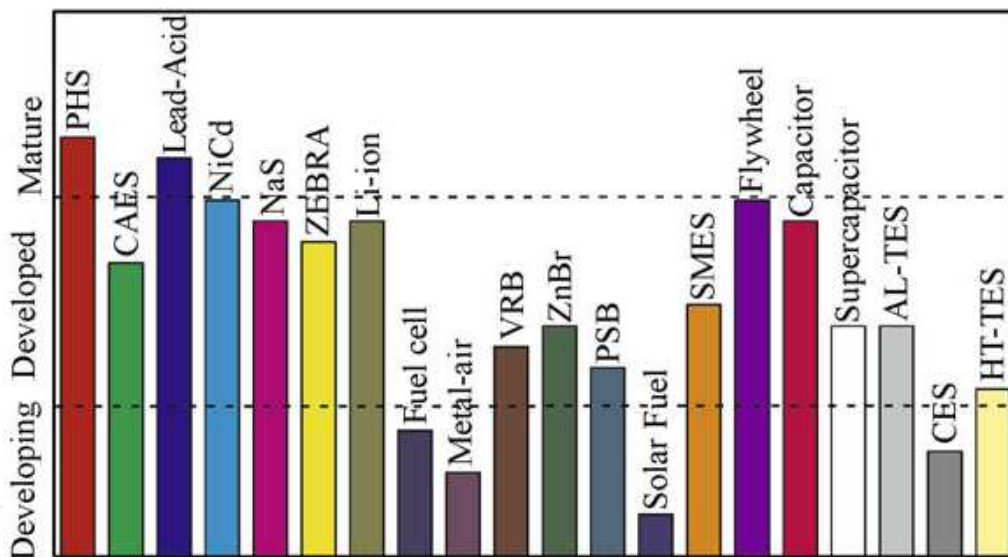

Figure 17. Technical maturity of EES systems [69]

9.2. Power rating and discharge time

The power ratings of various EESs are compared in Table 1. Broadly, the EESs fall into three types according to their applications [69], [74]:

1. *Energy management*: PHS, CAES and CES are suitable for applications in scales above 100 MW with hourly to daily output durations. They can be used for energy management for large-scale generations such as load leveling, ramping/load following, and spinning reserve. Large-scale batteries, flow batteries, fuel cells, CES and TES are suitable for medium-scale energy management with a capacity of 10–100 MW [55], [69].

2. *Power quality:* Flywheel, batteries, SMES, capacitor and supercapacitor have a fast response (~milliseconds) and therefore can be utilized for power quality such as the instantaneous voltage drop, flicker mitigation and short duration UPS. The typical power rating for this kind of application is lower than 1 MW [55].
3. *Bridging power:* Batteries, flow batteries, fuel cells and Metal-Air cells not only have a relatively fast response (<~1 s) but also have relatively long discharge time (hours), therefore they are more suitable for bridging power. The typical power rating for these types of applications is about 100 kW–10 MW [55], [74].

Systems	Power rating and discharge time		Storage duration		Capital cost		
	Power rating	Discharge time	Self discharge per day	Suitable storage duration	\$/kW	\$/kWh	€/kWh-Per cycle
PHS	100–5000 MW	1–24 h+	Very small	Hours–months	600–2000	5–100	0.1–1.4
CAES	5–300 MW	1–24 h+	Small	Hours–months	400–800	2–50	2–4
Lead-acid	0–20 MW	Seconds–hours	0.1–0.3%	Minutes–days	300–600	200–400	20–100
NiCd	0–40 MW	Seconds–hours	0.2–0.6%	Minutes–days	500–1500	800–1500	20–100
NaS	50 kW–8 MW	Seconds–hours	~20%	Seconds–hours	1000–3000	300–500	8–20
ZEBRA	0–300 kW	Seconds–hours	~15%	Seconds–hours	150–300	100–200	5–10
Li-ion	0–100 kW	Minutes–hours	0.1–0.3%	Minutes–days	1200–4000	600–2500	15–100
Fuel cells	0–50 MW	Seconds–24 h+	Almost zero	Hours–months	10,000+		6000–20,000
Metal-Air	0–10 kW	Seconds–24 h+	Very small	Hours–months	100–250	10–60	
VRB	30 kW–3 MW	Seconds–10 h	Small	Hours–months	600–1500	150–1000	5–80
ZnBr	50 kW–2 MW	Seconds–10 h	Small	Hours–months	700–2500	150–1000	5–80
PSB	1–15 MW	Seconds–10 h	Small	Hours–months	700–2500	150–1000	5–80
Solar fuel	0–10 MW	1–24 h+	Almost zero	Hours–months	–	–	–
SMES	100 kW–10 MW	Milliseconds–8 s	10–15%	Minutes–hours	200–300	1000–10,000	
Flywheel	0–250 kW	Milliseconds–15 min	100%	Seconds–minutes	250–350	1000–5000	3–25
Capacitor	0–50 kW	Milliseconds–60 min	40%	Seconds–hours	200–400	500–1000	
Super-capacitor	0–300 kW	Milliseconds–60 min	20–40%	Seconds–hours	100–300	300–2000	2–20
AL-TES	0–5 MW	1–8 h	0.5%	Minutes–days		20–50	
CES	100 kW–300 MW	1–8 h	0.5–1.0%	Minutes–days	200–300	3–30	2–4
HT-TES	0–60 MW	1–24 h+	0.05–1.0%	Minutes–months		30–60	

Table 1. Comparison of technical characteristics of EES systems [69]

9.3. Storage duration

Table 1 also illustrates the self-discharge (energy dissipation) per day for EES systems. One can see that PHS, CAES, Fuel Cells, Metal-Air Cells, solar fuels and flow batteries have a very small self-discharge ratio so are suitable for a long storage period. Lead-Acid, NiCd, Li-ion, TESs and CES have a medium self-discharge ratio and are suitable for a storage period not longer than tens of days [69].

NaS, ZEBRA, SMES, capacitor and supercapacitor have a very high self-charge ratio of 10–40% per day. They can only be implemented for short cyclic periods of a maximum of several hours. The high self-discharge ratios of NaS and ZEBRA are from the high working temperature which needs to be self-heating to maintain the use of the storage energy [69].

Flywheels will discharge 100% of the stored energy if the storage period is longer than about 1 day. The proper storage period should be within tens of minutes.

9.4. Capital cost

Capital cost is one of the most important factors for the industrial take-up of the EES. They are expressed in the forms shown in Table 2, cost per kWh, per kW and per kWh per cycle. All the costs per unit energy shown in the table have been divided by the storage efficiency to obtain the cost per output (useful) energy [69]. The per cycle cost is defined as the cost per unit energy divided by the cycle life which is one of the best ways to evaluate the cost of energy storage in a frequent charge/discharge application, such as load levelling. For example, while the capital cost of lead-acid batteries is relatively low, they may not necessarily be the least expensive option for energy management (load levelling) due to their relatively short life for this type of application. The costs of operation and maintenance, disposal, replacement and other ownership expenses are not considered, because they are not available for some emerging technologies [55], [69].

Systems	Energy and power density				Life time and cycle life		Influence on environment	
	Wh/kg	W/kg	Wh/L	W/L	Life time (years)	Cycle life (cycles)	Influence	Description
PHS	0.5–1.5		0.5–1.5		40–60		Negative	Destruction of trees and green land for building the reservoirs
CAES	30–60		3–6	0.5–2.0	20–40		Negative	Emissions from combustion of natural gas
Lead-acid	30–50	75–300	50–80	10–400	5–15	500–1000	Negative	Toxic remains
NiCd	50–75	150–300	60–150		10–20	2000–2500		
NaS	150–240	150–230	150–250		10–15	2500		
ZEBRA	100–120	150–200	150–180	220–300	10–14	2500+		
Li-ion	75–200	150–315	200–500		5–15	1000–10,000+		
Fuel cell	800–10,000	500+	500–3000	500+	5–15	1000+	Negative	Remains and/or combustion of fossil fuel
Metal-Air	150–3000		500–10,000			100–300	Small	Little amount of remains
VRB	10–30		16–33		5–10	12,000+	Negative	Toxic remains
ZnBr	30–50		30–60		5–10	2000+		
PSB	–	–	–	–	10–15			
Solar fuel	800–100,000		500–10,000		–	–	Benign	Usage and storage of solar energy
SMES	0.5–5	500–2000	0.2–2.5	1000–4000	20+	100,000+	Negative	Strong magnetic fields
Flywheel	10–30	400–1500	20–80	1000–2000	~15	20,000+	Almost none	
Capacitor Super-	0.05–5	~100,000	2–10 capacitor	100,000+ 2.5–15	~5 500–5000	50,000+ 10–30	Small	Little amount of remains 100,000+
20+		100,000+	Small	Little amount of remains				
AL-TES	80–120		80–120		10–20		Small	
CES	150–250	10–30	120–200		20–40		Positive	Removing contaminates during air liquefaction (Charge)
HT-TES	80–200		120–500		5–15		Small	

Table 2. Comparison of technical characteristics of EES systems [69]

CAES, Metal-Air battery, PHS, TESs and CES are in the low range in terms of the capital cost per kWh. The Metal-Air batteries may appear to be the best choice based on their high energy density and low cost, but they have a very limited life cycle and are still under development. Among the developed techniques, CAES has the lowest capital cost compared to all the other systems. The capital cost of batteries and flow batteries is slightly higher than the break even cost against the PHS although the gap is gradually closing. The SMES, flywheel, capacitor and supercapacitor are suitable for high power and short duration

applications, since they are cheap on the output power basis but expensive in terms of the storage energy capacity [55], [69].

The costs per cycle kWh of PHS and CAES are among the lowest among all the EES technologies, the per cycle cost of batteries and flow batteries are still much higher than PHS and CAES although a great decrease has occurred in recent years. CES is also a promising technology for low cycle cost. However, there are currently no commercial products available. Fuel cells have the highest per cycle cost and it will take a long time for them to be economically competitive. No data have been found for the solar fuels as they are in the early stage of development [55], [69].

It should also be noted that the capital cost of energy storage systems can be significantly different from the estimations given here due to, for example, breakthroughs in technologies, time of construction, location of plants, and size of the system. The information summarised here should only be regarded as being preliminary.

9.5. Cycle efficiency

The cycle efficiency of EES systems during one charge-discharge cycle is illustrated in Figure 18. The cycle efficiency is the “round-trip” efficiency defined as ratio between output energy and input energy. The self-discharge loss during the storage is not considered. One can see that the EES systems can be broadly divided into three groups:

1. *Very high efficiency:* SMES, flywheel, supercapacity and Li-ion battery have a very high cycle efficiency of > 90%.
2. *High efficiency:* PHS, CAES, batteries (except for Li-ion), flow batteries and conventional capacitor have a cycle efficiency of 60–90%. It can also be seen that storing electricity by compression and expansion of air using the CAES is usually less efficient than pumping and discharging water with PHSs, since rapid compression heats up a gas, increasing its pressure thus making further compression more energy consuming [55], [69].
3. *Low efficiency:* Hydrogen, DMFC, Metal-Air, solar fuel, TESs and CES have an efficiency lower than ~60% mainly due to large losses during the conversion from the commercial AC side to the storage system side. For example, hydrogen storage of electricity has relatively low round-trip energy efficiency (~20–50%) due to the combination of electrolyser efficiency and the efficiency of re-conversion back to electricity [55], [69].

It must be noted that there is a trade-off between the capital cost and round-trip efficiency, at least to some extent. For example, a storage technology with a low capital cost but a low round-trip efficiency may well be competitive with a high cost, high round-trip efficiency technology.

9.6. Energy and power density

The power density (W/kg or W/litre) is the rated output power divided by the volume of the storage device. The energy density is calculated as a stored energy divided by the volume. The volume of the storage device is the volume of the whole energy storage system

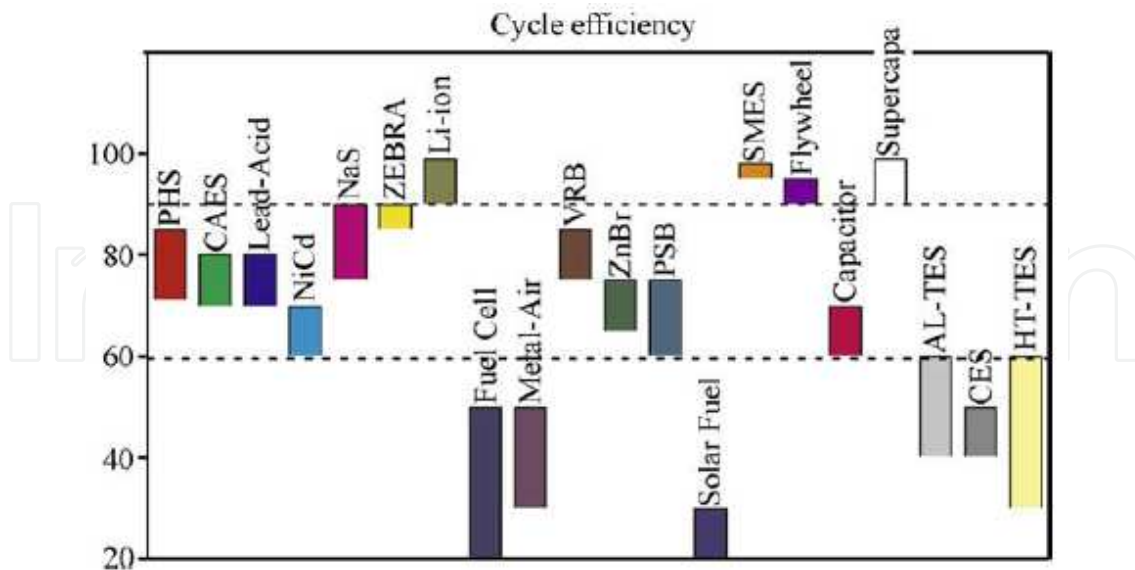

Figure 18. Cycle efficiency of EES systems. [69]

including the energy storing element, accessories and supporting structures, and the inverter system. As can be seen from Table 1, the Fuel Cells, Metal-Air battery, and Solar fuels have an extremely high energy density (typically ~ 1000 Wh/kg), although, as mentioned above, their cycle efficiencies are very low. Batteries, TESs, CES and CAES have medium energy density. The energy density of PHS, SMES, Capacitor/supercapacitor and flywheel are among the lowest below ~ 30 Wh/kg. However, the power densities of SMES, capacitor/supercapacitor and flywheel are very high which are, again, suitable for applications for power quality with large discharge currents and fast responses [69], [74]. NaS and Li-ion have a higher energy density than other conventional batteries. The energy densities of flow batteries are slightly lower than those of conventional batteries. It should be noted that there are differences in the energy density of the same type of EES made by different manufacturers [55].

9.7. Life time and cycle life

Also compared in Table 1 are life time and/or cycle life for various EESs. It can be seen that the cycle lives of EES systems whose principles are largely based on the electrical technologies are very long normally greater than 20,000. Examples include SMES, capacitor and supercapacitor. Mechanical and thermal energy storage systems, including PHS, CAES, flywheel, AL-TES, CES and HT-TES, also have long cycle lives. These technologies are based on conventional mechanical engineering, and the life time is mainly determined by the life time of the mechanical components. The cycle abilities of batteries, flow batteries, and fuel cells are not as high as other systems due to chemical deterioration with the operating time. Metal-Air battery only has a life of a few hundred cycles and obviously needs to be further developed [55], [69].

10. Conclusion

The key element of this analysis is the review of the available energy storage techniques applicable to electrical power systems.

There is obviously a cost associated to storing energy, but we have seen that, in many cases, storage is already cost effective. More and more application possibilities will emerge as further research and development is made in the field [91].

Storage is a major issue with the increase of renewable but decentralized energy sources that penetrate power networks [93]. Not only is it a technical solution for network management, ensuring real-time load leveling, but it is also a mean of better utilizing renewable resources by avoiding load shedding in times of overproduction. Coupled with local renewable energy generation, decentralized storage could also improve power network sturdiness through a network of energy farms supplying a specific demand zone.

Many solutions are available to increase system security, but they are so different in terms of specifications that they are difficult to compare. This is why we tried to bring out a group of technical and economical characteristics which could help improve performance and cost estimates for storage systems.

Based on the review, the following conclusions could be drawn [55], [69], [74]:

1. Although there are various commercially available EES systems, no single storage system meets all the requirements for an ideal EES - being mature, having a long lifetime, low costs, high density and high efficiency, and being environmentally benign. Each EES system has a suitable application range. PHS, CAES, large-scale batteries, flow batteries, fuel cells, solar fuels, TES and CES are suitable for energy management application; flywheels, batteries, capacitors and supercapacitors are more suitable for power quality and short duration UPS, whereas batteries, flow batteries, fuel cells and Metal-Air cells are promising for the bridging power.
2. PHS and Lead-Acid battery are technically mature; CAES, NiCd, NaS, ZEBRA Li-ion, flow battery, SMES, flywheel, capacitor, Supercapacitor, AL-TES and HT-TES are technically developed and commercially available; Fuel Cell, Meta-Air battery, Solar Fuel and CES are under development. The capital costs of CAES, Metal-Air battery, PHS, TES and CES are lower than other EESs. CAES has the lowest capital cost among the developed technologies. Metal-Air battery has the potential to be the cheapest among currently known EES systems.
3. The cycle efficiencies of SMES, flywheel, capacitor/supercapacitor, PHS, CAES, batteries, flow batteries are high with the cycle efficiency above 60%. Fuel Cell, DMFC, Metal-Air, solar fuel, TES and CES have a low efficiency mainly due to large losses during the conversion from commercial AC to the storage energy form.
4. The cycle lives of the EES systems based on the electrical technologies, such as SMES, capacitor and supercapacitor, are high. Mechanical and thermal based EES, including PHS, CAES, flywheel, ALTES, CES and HT-TES, also have a long cycle life. The cycle abilities of batteries, flow batteries, and fuel cells are not as high as other systems due to

chemical deterioration with the operating time. Metal-Air battery has the lowest life time at least currently.

5. PHS, CAES, batteries, flow batteries, fuel cells and SMES are considered to have some negative effects on the environment due to one or more of the following: fossil combustion, strong magnetic field, landscape damage, and toxic remains. Solar fuels and CES are more environmentally friendly. However, a full life-cycle analysis should be done before a firm conclusion can be drawn.

Based on the contents of this study and carefully measuring the stakes, we find that:

1. The development of storage techniques requires the improvement and optimization of power electronics, often used in the transformation of electricity into storable energy, and vice versa.
2. The rate of penetration of renewable energy will require studies on the influence of the different storage options, especially those decentralized, on network sturdiness and overall infrastructure and energy production costs.
3. The study of complete systems (storage, associated transformation of electricity, power electronics, control systems...) will lead to the optimization of the techniques in terms of cost, efficiency, reliability, maintenance, social and environmental impacts, etc.
4. It is important to assess the national interest for compressed gas storage techniques.
5. Investment in research and development on the possibility of combining several storage methods with a renewable energy source will lead to the optimization of the overall efficiency of the system and the reduction of greenhouse gases created by conventional gas-burning power plants.
6. Assessing the interest for high-temperature thermal storage systems, which have a huge advantage in terms of power delivery, will lead to the ability of safely establish them near power consumption areas,
7. The development of supercapacitors will lead to their integration into the different types of usage.
8. The development of low-cost, long-life flywheel storage systems will lead to increased potential, particularly for decentralized applications.
9. To increase the rate of penetration and use of hydrogen-electrolyser fuel-cell storage systems, a concerted R&D effort will have to be made in this field.

Author details

Hussein Ibrahim

TechnoCentre éolien, Gaspé, QC, Canada

Adrian Ilinca

Université du Québec à Rimouski, Rimouski, QC, Canada

11. References

- [1] Smith, S.C.; Sen, P.K.; Kroposki, B., Advancement of Energy Storage Devices and Applications in Electrical Power System. Power and Energy Society General Meeting - Conversion and Delivery of Electrical Energy in the 21st Century, 22-24 2008

- [2] P.C. Ghosh , B. Emonts, H. Janßen, J. Mergel, D. Stolten. "Ten years of operational experience with a hydrogen-based renewable energy supply system", *Solar Energy* 75, 2003, pp. 469–478
- [3] A. Bilodeau, K. Agbossou. Control analysis of renewable energy system with hydrogen storage for residential applications, *Journal of Power Sources*, 2005.
- [4] N.Hamsic, A.Schmelter, A.Mohd, E.Ortjohann, E.Schultze, A.Tuckey, J.Zimmermann. "Stabilising the Grid Voltage and Frequency in Isolated Power Systems Using a Flywheel Energy Storage System," *The Great Wall World Renewable Energy Forum* , Beijing, China, October 2006
- [5] E.Ortjohann, N.Hamsic , A.Schmelter , A.Mohd, J.Zimmermann, A.Tuckey, E.Schultze. Increasing Renewable Energy Penetration in Isolated Grids Using a Flywheel Energy Storage System, the first International Conference on Power Engineering, Energy and Electrical Drives (POWERENG,IEEE),Portugal, April 2007.
- [6] European Renewable Energy Council, "Renewable energy in Europe: building Markets and capacity," James and James science publishers, August 2004.
- [7] "FP7 Research Priorities for the Renewable Energy Sector", Bruxelles, EUREC Agency, March 2005.
- [8] Melissa M, "Flywheel Energy Storage System: The current status and future prospect," Trinity Power Corporation, February 2004, pp.8-11.
- [9] A.Ruddell, G.Schönnenbeck, R.Jones, "Flywheel Energy Storage Systems," Rutherford Appleton Lab, UK.
- [10] H.Bindner, "Power Control for Wind Turbines in Weak Grids," Risø National Lab, March 1999.
- [11] Alaa Mohd, Egon Ortjohann, Andreas Schmelter, Nedzad Hamsic, Danny Morton. Challenges in integrating distributed Energy storage systems into future smart grid. IEEE International Symposium on Industrial Electronics, June 30 - July 2, 2008.
- [12] James A. McDowall, "Status and Outlook of the Energy Storage Market," PES 2007, Tampa, July 2007.
- [13] Baker JN, Collinson A. Electrical energy storage at the turn of the millennium. *Power Eng J* 1999;6:107–12.
- [14] Dti Report. Status of electrical energy storage systems. DG/DTI/00050/00/00, URN NUMBER 04/1878, UK Department of Trade and Industry; 2004, p. 1–24.
- [15] Australian Greenhouse Office. Advanced electricity storage technologies programme. ISBN: 1 921120 37 1, Australian Greenhouse Office; 2005, p. 1–35.
- [16] Ahearne J. Storage of electric energy, Report on research and development of energy technologies. International Union of Pure and Applied Physics; 2004, p. 76–86. Available online <http://www.iupap.org/wg/energy/report-a.pdf>
- [17] http://www.en.wikipeida.org/wiki/Hydroelectric_energy_storage
- [18] Linden S. The commercial world of energy storage: a review of operating facilities (under construction or planned). In: *Proceeding of 1st annual conference of the energy storage council*, Houston, Texas, March 3, 2003.

- [19] Walawalkar R, Apt J, Mancini R. Economics of electric energy storage for energy arbitrage and regulation. *Energy Policy* 2007;5:2558–68.
- [20] Dti Report. Review of electrical energy storage technologies and systems and of their potential for the UK. DG/DTI/00055/00/00, URN NUMBER 04/1876, UK Department of Trade and Industry; 2004, p. 1–34.
- [21] Bueno C, Carta JA. Wind powered pumped hydro storage systems, a means of increasing the penetration of renewable energy in the Canary Islands. *Renew Sus Energy Rev* 2006;10:312–40.
- [22] Najjar Y, Zaamout MS. Performance analysis of compressed air energy storage (CAES) plant for dry regions. *Energy Convers Manage* 1998;39:1503–11.
- [23] Sears JR. TEX: The next generation of energy storage technology. *Telecommunications Energy Conference, INTELEC 2004*. In: 26th annual international volume, Issue, Sept. 19–23 2004; p. 218–22.
- [24] Najjar Y, Jubeh N. Comparison of performance of compressed-air energy-storage plant with compressed-air storage with humidification. In: *Proceeding of IMechE, Part A: Journal of Power and Energy* 2006; 220:581–8.
- [25] Bullough C, Gatzen C, Jakiel C, et al. Advanced adiabatic compressed air energy storage for the integration of wind energy. In: *Proceedings of the European wind energy conference*. London, UK, 2004.
- [26] Wang S, Chen G, Fang M, et al. A new compressed air energy storage refrigeration system. *Energ Convers Manage* 2006;47:3408–16.
- [27] Cook GM, Spindler WC, Grefe G. Overview of battery power regulation and storage. *IEEE T Energy Conver* 1991;6:204–11.
- [28] Chalk SG, Miller JF. Key challenges and recent progress in batteries, fuel cells and hydrogen storage for clean energy systems. *J Power Sources* 2006;159:73–80.
- [29] Kashem MA, Ledwich G. Energy requirement for distributed energy resources with battery energy storage for voltage support in three-phase distribution lines. *Electr Pow Syst Res* 2007;77:10–23.
- [30] Kluiters EC, Schmal D, Ter Veen WR, et al. Testing of a sodium/ nickel chloride (ZEBRA) battery for electric propulsion of ships and vehicles. *J Power Sources* 1999;80:261–4.
- [31] Karpinski AP, Makovetski B, Russell SJ, et al. Silver-zinc: status of technology and applications. *J Power Sources* 1999;80:53–60.
- [32] Linden S. Bulk energy storage potential in the USA, current developments and future prospects. *Energy* 2006; 31:3446–57.
- [33] Chalk SG, Miller JF. Key challenges and recent progress in batteries, fuel cells and hydrogen storage for clean energy systems. *J Power Sources* 2006;159:73–80.
- [34] Weinmann O. Hydrogen-the flexible storage for electrical energy. *Power Eng J-Special Feature: Electrical energy storage* 1999:164–70.
- [35] Steinfeld A, Meier A. Solar thermochemical process technology. In: *Encycl Energy*. Elsevier Inc; 2004, 5: 623-37.

- [36] Kolkert WJ, Jamet F. Electric energy gun technology: status of the French–German–Netherlands programme. *IEEE T Magn* 1999; 35:25–30.
- [37] Koshizuka N, Ishikawa F, Nasu H. Progress of superconducting bearing technologies for flywheel energy storage systems. *Physica C* 2003;386:444–50.
- [38] Xue X, Cheng K, Sutanto D. A study of the status and future of superconducting magnetic energy storage in power systems. *Supercond Sci Tech* 2006;19:39.
- [39] Kondoh J, Ishii I, Yamaguchi H, et al. Electrical energy storage systems for energy networks. *Energ Convers Manage* 2000;41:1863–74
- [40] Suzuki Y, Koyanagi A, Kobayashi M. Novel applications of the flywheel energy storage system. *Energy* 2005; 30:2128–43.
- [41] <http://www.beaconpower.com/products/EnergyStorageSystems/flywheels.htm>
- [42] Rosen MA. Second-law analysis of aquifer thermal energy storage systems. *Energy* 1999; 24:167–82.
- [43] Ameri M, Hejazi SH, Montaser K. Performance and economics of the thermal energy storage systems to enhance the peaking capacity of the gas turbines. *Appl Therm Eng* 2005; 25:241–51.
- [44] Akbari H, Sezgen O. Performance evaluation of thermal energy storage systems. *Energ Buildings* 1995; 22:15–24.
- [45] Ordonez CA, Plummer MC. Cold thermal storage and cryogenic heat engines for energy storage applications. *Energy Sources* 1997; 19(4):389–96.
- [46] Kessling W, Laevemann E, Peltzer M. Energy storage in open cycle liquid desiccant cooling systems. *Int J Refrig* 1998; 21(2):150–6.
- [47] Kishimoto K, Hasegawa K, Asano T. Development of generator of liquid air storage energy system. Mitsubishi Heavy Industries, Ltd. *Technical Review*, 1998; 35(3):117–20.
- [48] Chen HS, Ding YL. A cryogenic energy system using liquid/slush air as the energy carrier and waste heat and waste cold to maximise efficiency, specifically it does not use combustion in the expansion process. UK Patent G042226PT, 2006-02-27.
- [49] Wen DS, Chen HS, Ding YL, et al. Liquid nitrogen injection into water: pressure build-up and heat transfer. *Cryogenics* 2006; 46: 740–8.
- [50] Chen HS, Ding YL, Toby P, et al. A method of storing energy and a cryogenic energy storage system. International Patent WO/2007/ 096656, 2007-08-30.
- [51] McLarnon FR, Cairns EJ. Energy storage. *Ann Rev Energy* 1989;14:241–71.
- [52] Dobie WC. Electrical energy storage. *Power Eng J* 1998; 12:177–81.
- [53] Koot M, Kessels J, Jager B, et al. Energy management strategies for vehicular electric power systems. *IEEE T Veh Technol* 2005; 54:771–82.
- [54] Weinstock IB. Recent advances in the US Department of Energy's energy storage technology research and development programs for hybrid electric and electric vehicles. *J Power Sources* 2002; 110:471–4.
- [55] Energy Storage Association, www.electricitystorage.org

- [56] Ibrahim H., A. Ilinca, R. Younès, J. Perron, T. Basbous, "Study of a Hybrid Wind-Diesel System with Compressed Air Energy Storage", IEEE Canada, EPC2007, Montreal, Canada, October 25-26, 2007.
- [57] H. Ibrahim, A. Ilinca, J. Perron, "Solutions actuelles pour une meilleure gestion et intégration de la ressource éolienne". CSME/SCGM Forum 2008 at Ottawa. The Canadian Society for Mechanical Engineering, 5-8 Juin 2008
- [58] David Connolly. A Review of Energy Storage Technologies For the integration of fluctuating renewable energy. Ph.D. project, University of Limerick, October 2010.
- [59] Baxter, R., Energy Storage - A Nontechnical Guide, PennWell Corporation, Oklahoma, 2006.
- [60] Energy Storage Systems, Sandia National Laboratories, 14th October 2007,
- [61] Gonzalez, A., Ó'Gallachóir, B., McKeogh, E. & Lynch, K. Study of Electricity Storage Technologies and Their Potential to Address Wind Energy Intermittency in Ireland. Sustainable Energy Ireland, 2004.
- [62] Makansi J, Abboud J. Energy storage: the missing link in the electricity value chain-An ESC White Paper. Energy storage Council 2002; p. 1-23.
- [63] Moore T, Douglas J. Energy storage, big opportunities on a smaller scale. EPRI J 2006; Spring Issue, p. 16–23.
- [64] Mears D. EPRI-DOE storage handbook-storage for wind resources. In: Annual peer review meeting of DOE energy storage systems research. Washington DC, USA, Nov. 10–11, 2004, p. 1–18.
- [65] Ribeiro PF, Johson BK, Crow ML, et al. Energy storage systems for advanced power applications. In: Proceedings of the IEEE 2001;89:1744–56.
- [66] Ratering-Schnitzler B, Harke R, Schroeder M, et al. Voltage quality and reliability from electrical energy-storage systems. J Power Sources 1997;67:173–7.
- [67] Y. Rebours, D. Kirschen. "What is spinning reserve?", The University of Manchester ,Sept 2005.
- [68] Market Analysis of Emerging Electric Energy Storage Systems. National Energy Technology Laboratory. DOE/NETL-2008/1330. July 31, 2008
- [69] Haisheng Chen, Thang Ngoc Cong, Wei Yang, Chunqing Tan, Yongliang Li, Yulong Ding. Progress in electrical energy storage system: A critical review. Progress in Natural Science. July 2008.
- [70] James M. Eyer, Joseph J. Iannucci, Garth P. Corey. "Energy Storage Benefits and Market Analysis Handbook, "Sandia National Laboratories REPORT, SAND2004-6177, December 2004.
- [71] <http://www.buchmann.ca>
- [72] Mears, D. Gotschall, H. EPRI-DOE Handbook of Energy Storage for Transmission and Distribution Applications. Electric Power Research Institute Report #1001834. December 2003.
- [73] Jim Eyer, Garth Corey. Energy Storage for the Electricity Grid: Benefits and Market Potential Assessment Guide. SANDIA REPORT SAND2010-0815, February 2010.

- [74] H. Ibrahim, A. Ilinca, J. Perron, Energy storage systems—Characteristics and comparisons, *Renewable and Sustainable Energy Reviews*, Volume 12, Issue 5, June 2008, Pages 1221–1250.
- [75] Robin G, Rullan M, Multon B, Ben Ahmaed H, Glorennec PY. Solutions de stockage de l'énergie pour les systèmes de production intermittente d'électricité renouvelable. 2004.
- [76] Shoening, Dr. Susan M. Hassenzahl, William M. Long - versus Short-Term Energy Storage Technologies Analysis, A Lifecycle Cost Study. Sandia National Laboratories, Energy Storage Program, Office of Electric Transmission and Distribution, U.S. Department of Energy. Sandia National Laboratories Report #SAND2003-2783. August 2003.
- [77] Gergaud O. Modélisation énergétique et optimisation économique d'un système de production éolien et photovoltaïque couplé au réseau et associé à un accumulateur. Thèse de l'ENS de Cachan; décembre 2002.
- [78] Mémoire concernant la contribution possible de la production éolienne en réponse à l'accroissement de la demande québécoise d'électricité d'ici 2010. Régie de l'énergie, Québec, Canada. Dossier R-3526; Avril 2004.
- [79] R. Messenger R, Ventre J. Photovoltaic systems engineering. CRC Press, 1999.
- [80] Emerging Energy Storage Technologies in Europe. Rapport Frost & Sullivan; 2003.
- [81] Bonneville JM. Stockage cinétique. Institut de Recherche de l'Hydro-Québec, Varennes, Québec, Canada. Rapport interne; février 1975.
- [82] IEEE 1547 Standard for Interconnecting Distributed Resources with Electric Power Systems. Approved by the IEEE Standards Board in June 2003. Approved as an American National Standard in October 2003.
- [83] Faure F. Suspension magnétique pour volant d'inertie. Thèse de doctorat. Institut National Polytechnique de Grenoble, France; Juin 2003.
- [84] Alaa Mohd, Egon Ortjohann, Andreas Schmelter, Nedzad Hamsic, Danny Morton. Challenges in integrating distributed Energy storage systems into future smart grid. IEEE International Symposium on Industrial Electronics, June 30 - July 2, 2008.
- [85] Rudell A. Storage and Fuel Cells. EPSRC SuperGen Workshop : Future Technologies for a Sustainable Electricity System. Univ. of Cambridge, 7 novembre 2003.
- [86] Lead/acid batteries, University of Cambridge, 15th October 2007, http://www.doitpoms.ac.uk/tlplib/batteries/batteries_lead_acid.php
- [87] Sergio Vazquez, Srdjan M. Lukic, Eduardo Galvan, Leopoldo G. Franquelo, Juan M. Carrasco, Energy Storage Systems for Transport and Grid Applications, IEEE TRANSACTIONS ON INDUSTRIAL ELECTRONICS, VOL. 57, NO. 12, DECEMBER 2010, Pages. 3881-3895.
- [88] www.cea.fr
- [89] http://www.power-thru.com/flywheel_detail.html
- [90] Anzano JP, Jaud P, Madet D. Stockage de l'électricité dans le système de production électrique. Techniques de l'ingénieur, traité de Génie Électrique D4030; 1989.

- [91] Multon B, Ruer J. Stocker l'électricité : Oui, c'est indispensable, et c'est possible ! pourquoi, où, comment?. Publication ECRIN en contribution au débat national sur l'énergie; Avril 2003.
- [92] Robyns B. Contribution du stockage de l'énergie électrique à la participation au services système des éoliennes. Séminaire SRBE – SEE – L2EP « Éolien et réseaux : enjeux », 22 mars 2005.
- [93] Multon B. L'énergie électrique : analyse des ressources et de la production. Journées section électrotechnique du club EEA. Paris, France, 28-29 janvier 1999, p. 8.

IntechOpen