

We are IntechOpen, the world's leading publisher of Open Access books Built by scientists, for scientists

4,800

Open access books available

122,000

International authors and editors

135M

Downloads

Our authors are among the

154

Countries delivered to

TOP 1%

most cited scientists

12.2%

Contributors from top 500 universities



WEB OF SCIENCE™

Selection of our books indexed in the Book Citation Index
in Web of Science™ Core Collection (BKCI)

Interested in publishing with us?
Contact book.department@intechopen.com

Numbers displayed above are based on latest data collected.

For more information visit www.intechopen.com



Clinical Motor and Cognitive Neurobehavioral Relationships in the Basal Ganglia

Gerry Leisman, Robert Melillo and Frederick R. Carrick

Additional information is available at the end of the chapter

<http://dx.doi.org/10.5772/55227>

1. Introduction

The traditional view that the basal ganglia and cerebellum are simply involved in the control of movement has been challenged in recent years. One of the pivotal reasons for this reappraisal has been new information about basal ganglia and cerebellar connections with the cerebral cortex. In essence, recent anatomical studies have revealed that these connections are organized into discrete circuits or 'loops'. Rather than serving as a means for widespread cortical areas to gain access to the motor system, these loops reciprocally interconnect a large and diverse set of cerebral cortical areas with the basal ganglia and cerebellum. The properties of neurons within the basal ganglia or cerebellar components of these circuits resemble the properties of neurons within the cortical areas subserved by these loops. For example, neuronal activity within basal ganglia and cerebellar loops with motor areas of the cerebral cortex is highly correlated with parameters of movement, while neuronal activity within basal ganglia and cerebellar loops with areas of the prefrontal cortex is more related to aspects of cognitive function. Thus, individual loops appear to be involved in distinct behavioral functions. Studies of basal ganglia and cerebellar pathology support this conclusion. Damage to the basal ganglia or cerebellar components of circuits with motor areas of cortex leads to motor symptoms, whereas damage of the subcortical components of circuits with non-motor areas of cortex causes higher-order deficits. In this report, we review some of the new anatomical, physiological and behavioral findings that have contributed to a reappraisal of function concerning the basal ganglia and cerebellar loops with the cerebral cortex.

2. The basal ganglia in the context of behavior

The basal ganglia is part of a neuronal system that includes the thalamus, the cerebellum and the frontal lobes [1]. Like the cerebellum, the basal ganglion was previously thought to

be primarily involved in motor control. However, recently there has been much written about and the role of the basal ganglia in motor and cognitive functions has now been well established [2-6].

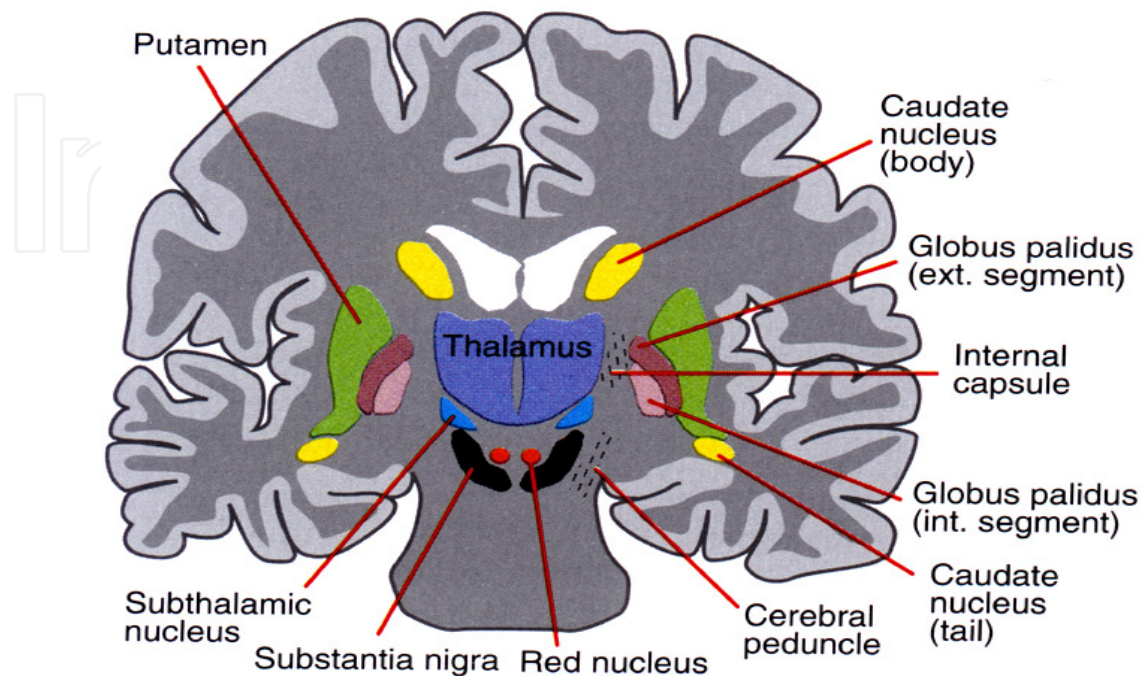

Figure 1. The basal ganglia that clinical include clinically includes subthalamic nucleus & substantia nigra whose component structures are highly interconnected. The striatum is associated with input signal and output associated with the globus pallidus & substantia nigra.

The basal ganglia is located in the diencephalon and is made up of five subcortical nuclei (represented in Fig.1): globus pallidus, caudate, putamen, substantia nigra and the subthalamic nucleus of Luys. The basal ganglia is thought to have expanded during the course of evolution as well and is therefore divided into the neo and paleostriatum. The paleostriatum consists primarily of the globus pallidus, which is derived embryologically from the diencephalon. During the course of its development it further divides into two distinct areas, the external and internal segments of the globus pallidus. The neostriatum is made up of two nuclei, the caudate and putamen. These two nuclei are fused anteriorly and are collectively known as the striatum. They are the input nuclei of the basal ganglia and they are derived embryologically from the telencephalon. The subthalamic nucleus of Luys lies inferiorly to the thalamus at the junction of the diencephalon and the mesencephalon or midbrain. The substantia nigra lays inferiorly to the thalamus and has two zones similar to the globus pallidus. A ventral pole zone called pars reticulata exists as well as a dorsal darkly pigmented zone called the pars compacta. The pars compacta contains dopaminergic neurons that contain the intenum. The globus pallidus intenum and the pars reticulata of the putamen are the major output nuclei of the basal ganglia. The globus pallidus intenum and the pars reticulata of the putamen are similar in cytology, connectivity, and function. These two nuclei can be considered to be a single structure divided by the internal capsule. Their relationship is similar to that of the caudate and putamen. The basal ganglia is part of

the extrapyramidal motor system as opposed to the pyramidal motor system that originates from the sensory-motor cerebral cortex. The pyramidal motor system is responsible for all voluntary motor activity except for eye movement. The extrapyramidal system modifies motor control and is thought to be involved with higher-order cognitive aspects of motor control as well as in the planning and execution of complex motor strategies, as well as the voluntary control of eye movements. There are two major pathways in the basal ganglia, the direct pathways, which promote movement, and the indirect pathways, which inhibit movement.

The basal ganglia receive afferent input from the entire cerebral cortex but especially from the frontal lobes. Almost all afferent connections to the basal ganglia terminate in the neostriatum (caudate and putamen). The neostriatum receives afferent input from two major sources outside of the basal ganglia, the cerebral cortex (cortico-striatal projections), and the intralaminar nucleus of the thalamus. The cortico-striatal projections contain topographically organized fibers originating from the entire cerebral cortex. An important component of that input comes from the centro-median nucleus from the thalamus and terminates in the putamen. Because the motor cortex of the frontal lobes projects to the centro-median nucleus, this may be an additional pathway by which the motor cortex can influence the basal ganglia. The putamen appears to be primarily concerned with motor control whereas the caudate appears to be involved in the control of eye movements and certain cognitive functions. The ventral striatum is related to limbic function, and therefore may affect autonomic and emotional functions.

The major output of the basal ganglia arises from the internal segment of the globus pallidus and the pars reticulata of the substantia nigra. The nuclei project in turn to three nuclei in the thalamus, the ventral lateral nuclei, the ventral anterior nuclei, and the mesio-dorsal nuclei, as well as the anterior thalamic nuclei. Internal segments of the globus pallidus project to the centro-median nucleus of the thalamus. Striatal neurons may be involved with gating incoming sensory input to higher motor areas such as the intralaminar thalamic nuclei and *premotor* cortex that arise from several modalities to coordinate behavioral responses. These different modalities may contribute to the perception of sensory input [7] leading to motor response. The basal ganglia are directed, in a way similar to the cerebellum, to premotor and motor cortices as well as the prefrontal cortex of the frontal lobes.

Experiments where Herpes simplex virus 1 (HSV-1) was administered into the dorsal lateral prefrontal cortex of monkeys to determine its axonal spread or connection, labeled the ipsilateral neurons in the internal segments of the globus pallidus and the contralateral dentate nucleus of the cerebellum [8]. It is therefore thought that this may show a role of both the cerebellum and basal ganglia in higher cognitive functions associates with the prefrontal cortex. This would also substantiate a cortico-striato-cerebello-thalamo-cortical loop, which would have a cognitive rather than motor function, exemplified in Fig. 2 below. The putamen is also thought to connect to the superior colliculus through non-dopaminergic axons that forms an essential link in voluntary eye movement.

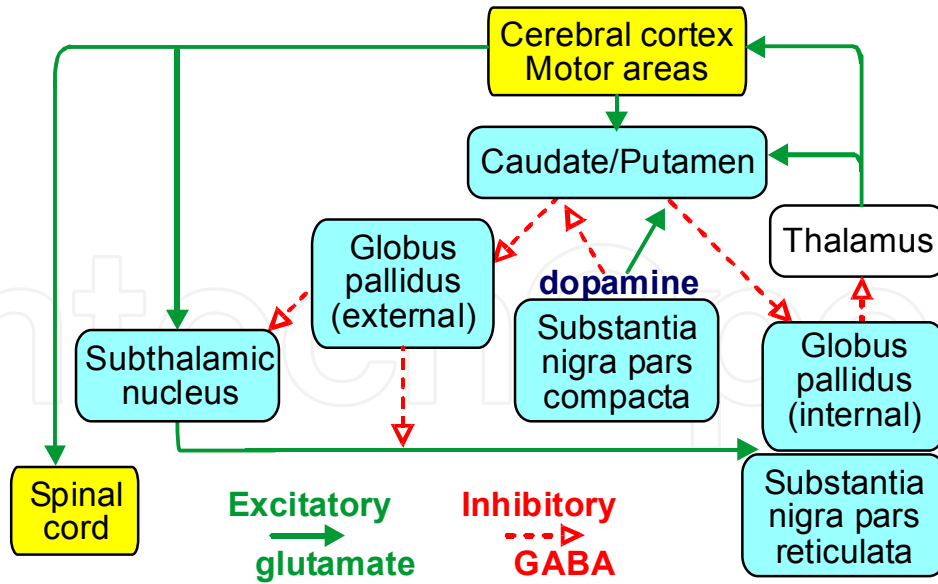

Figure 2. Circuitry of the basal ganglia. The cerebral cortex (and thalamus) projects to the striatum (excitatory pathways). The striatum also receives dopaminergic projections from the substantia nigra’s pars compacta (SNc). The striatum inhibits the globus pallidus (GP) as well as the substantia nigra’s pars reticulata (SN pr). The STN sends excitatory projections to the GPi, GPe & SNpr. GPi or SN pr inhibits (GABAergic) the thalamus. The thalamus projects to the cortex (also excitatory). The direct path leads to less inhibition of the thalamus, (i.e. the striatum inhibits GPi which in turn inhibits its normal (inhibitory) action on the thalamus, thus leading to greater excitation from the thalamus to the cortex. This allows for sustain actions or initiation of action. The indirect path excites the GPi thereby increasing its inhibition of the thalamus and thus suppresses unwanted movements.

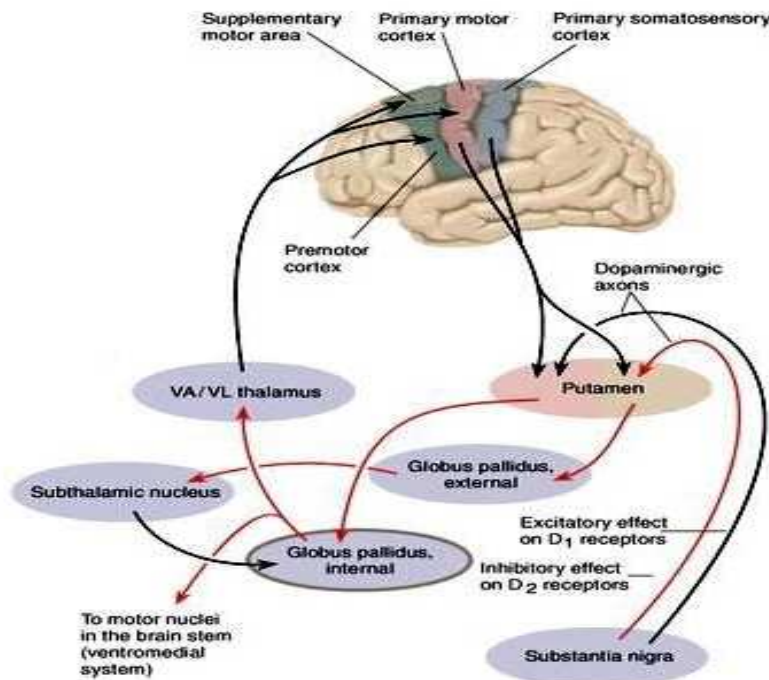

Figure 3. Cortical-basal ganglia pathways. All regions of cerebral cortex project to the basal ganglia, but output of basal ganglia is directed towards the frontal lobe, particularly pre-motor and supplementary motor cortex.

It is thought that normal basal ganglia function results from a balance of the direct and indirect striatal output pathway and different involvement of these pathways account for hyperkinesia or hypokinesia observed in disorders of the basal ganglia [9]. Hypokinesia is a disinhibition or increase in spontaneous movement (tics, tremors). It is thought that hypokinesia and hyperkinesia may relate to hypoactive behavior and hyperactive behavior associated with subcortical hypo-stimulation or hyper-stimulation of medial and orbito-frontal cortical circuits [10]. It is important to review these connections further to understand the role of basal ganglia in control of cognitive function.

Five fronto-subcortical circuits unite regions of the frontal lobe (the supplementary motor area; frontal eye fields; dorsolateral, prefrontal, orbito-frontal and anterior cingulate cortices) with the striatum, globus pallidus and thalamus in functional systems that mediate volitional motor activity, saccadic eye movements, executive functions, social behavior and motivation [10,11].

3. Direct and indirect pathways

Five major cortical to subcortical loops exist that make up cortico-striatal pathways. All cortical pathways initiate the direct and indirect pathways with the basal ganglia through excitatory glutamatergic cortico-striatal fibers (the general circuitry is described in Fig. 3 and direct and indirect pathways exemplified in Fig. 4). The direct pathway from the striatum sends GABA fibers (associated with dopamine receptors) from the striatum to the *globus pallidus* and putamen. The indirect pathway sends inhibitory GABA/enkephalin fibers (associated with D2 dopamine receptors) from the striatum to the globus pallidus. Indirect pathways then continue with inhibitory GABA fibers from the globus pallidus to the subthalamic nucleus of Luys. Indirect excitatory glutamatergic fibers then connect from the subthalamic nucleus to the globus pallidus and putamen. The basal ganglia then sends inhibitory outflow by GABA fibers from the globus pallidus and putamen to specific thalamic nuclei. The thalamus has excitatory fibers that return to the cortex [10]. Abnormalities of direct and indirect pathways result in different pathological functions.

The nature of the balance between components of these pathways is described in greater detail in the section below and described in Figs. 3-5. Hyperkinetic disorders (increased movement) are thought to be a selective loss of GABA/enkephalinergic intrinsic striatal neurons projecting to the lateral globus pallidus and substantia nigra. This results in decreased inhibitory stimulation to the thalamus leading to increased activity of the excitatory glutamatergic thalamocortical pathways and in turn greater neuronal activity in the premotor-motor and supplementary motor cortices [12]. The result is over-facilitation of motor programs resulting in increased motor activity. Hypokinetic disorders (decreased movement) are associated with decreased dopaminergic nigrostriatal stimulation from the substantia nigra to the striatum. This results in both excess outflow of the indirect striatal pathway and an inhibited direct striatal pathway. Both of these pathways increase thalamic inhibition and therefore decrease thalamocortical stimulation of motor cortical areas resulting in hypokinesia or decreased output of the frontal cortex [10,13,14]. It is possible

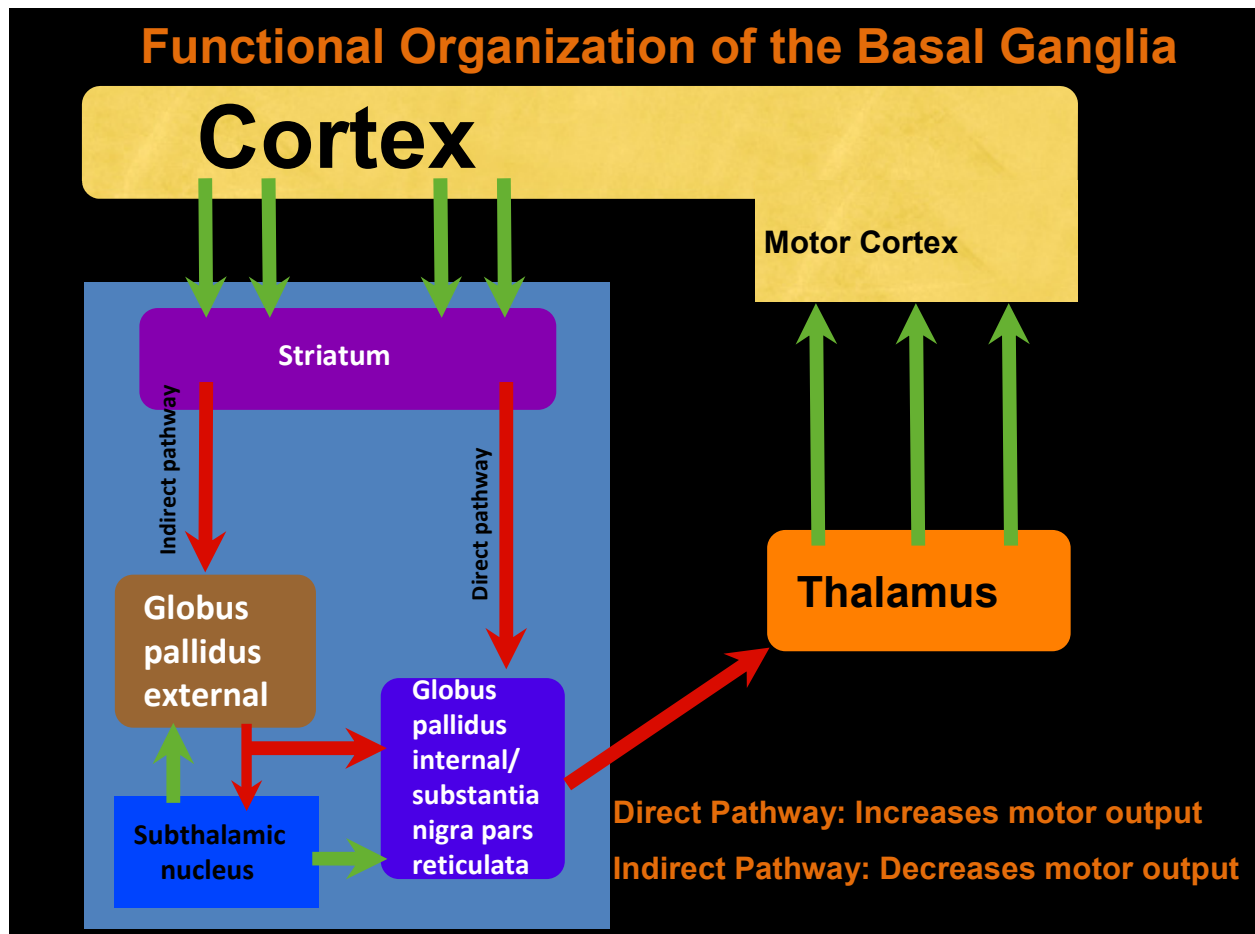

Figure 4. Direct and Indirect pathways. Direct pathway runs: Cortex→striatum→Gpi→thalamus→cortex. Two links are excitatory & two inhibitory, so the net effect of the whole sequence is excitatory. The cortex excites itself via the direct pathway. The Indirect pathway runs: cortex→striatum→GPe→STN→Gpi→thalamus→cortex. Three links are inhibitory and two excitatory, so the net effect of the sequence is inhibitory: The cortex inhibits itself via the indirect pathway. The total effect of basal ganglia upon the cortex results from complex interplay between these two pathways.

that the difference between hypokinetic and hyperkinetic syndromes may be different only in the timing and or the severity of the dysfunction. In this model, decreased thalamic excitation of the frontal cortex results in decreased excitation of the cortico-striatal fibers of the neostriatum. The neostriatum therefore decreases its inhibitions of the globus pallidus. There is then increased inhibition of the thalamocortical pathways leading to progressive hypokinesia. Eventually the lack of striatal inhibition of the globus pallidus results in its metabolic dysfunction and the rapid loss of GABA neurons. This can then result in decreased inhibition of thalamocortical pathways causing a sudden onset of hyperkinesia (increased movement) with the increased thalamic firing of the frontal cortex. There also appear to exist cognitive symptoms that parallel the motor effects. Previous studies have shown that patients with hyperkinetic, hypokinetic, Tourette's, and Obsessive-Compulsive disorders may exhibit neuropsychiatric disturbances such as apathy, depression, agitation, or excitability [15-20].

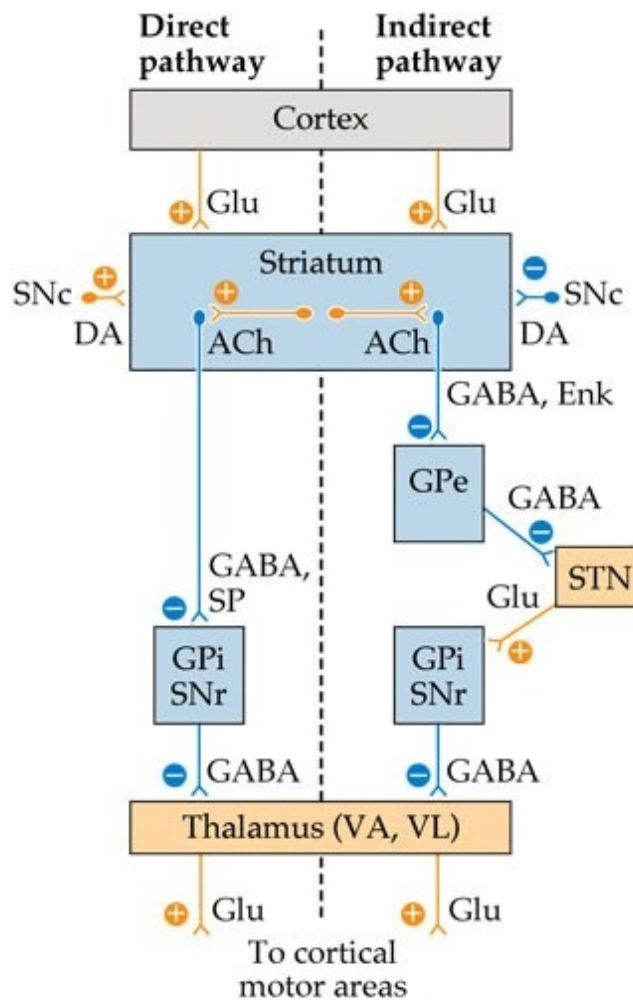

Figure 5. Circuit diagram for direct & indirect pathways. *Neurotransmitters:* Ach, acetylcholine; DA, dopamine; Glu, glutamate; Enk, enkaphalin; SP, substance P. *Nuclei:* SNc, substantia nigra pars compacta; SNr, substantia nigra pars reticulata; GPe, globus pallidus pars externa; GPi, globus pallidus pars interna; STN, subthalamic nucleus; VL, ventral lateral nucleus; VA, ventral anterior nucleus.

4. Clinical behavioral implications of pathway activity balance

Most disorders that involve the basal ganglia produce dysfunction by promoting an imbalance between the direct and indirect pathways. An increase in the relative activity in the direct pathways results in hyperkinetic movements and behaviors. This has been hypothesized to be a result of decreased activity of the indirect or increased activation of the direct pathway [11,13,14]. Increased relative activity in the indirect pathway is associated with hypokinetic movement and behaviors [21-23]. The majority of input to the basal ganglia comes from a top down direction through the five loops from the frontal lobe [24] referenced above. The premotor and supplementary motor areas, frontal and supplemental eye fields, the orbital frontal cortex, the dorsal lateral prefrontal cortex, and the anterior cingulate all connect into the basal ganglia governing voluntary motor activity, voluntary saccadic eye movement, social behavior, executive function, and motivation. These are then

connected to various areas within the thalamus and back to the cortex. The indirect pathway increases the output of the globus pallidus internus [25,26] and increases the inhibition of the thalamus and motor activity or behaviors. Increase in direct pathway function inhibits the output of the globus pallidus thereby promoting increased movement and cognitive behaviors.

One of the main clinical questions especially in the absence of any obvious damage or pathology is what promotes a functional imbalance between these pathways (represented in Fig. 5). Various disorders such as ADHD, Tourette's, OCD among other are known to involve the basal ganglia. In these disorders there is hyperkinetic movement and or behaviors that coincide with the particular loop that is affected, but in all cases the increase seems to be in the direct loop not the indirect loop [9,11,17-21].

The principle question here is why these disorders would target an increase in this pathway in particular. One of the differences may have to do with the receptors that are involved in one pathway more than the other. The D1 receptor is known to be found in the direct pathway while the D2 receptor is found in the indirect loop. The nigrostriatal pathway is believed to help promote movement through its dopaminergic activity in the zona compacta by connecting to the Putamen and increasing the activity of the D1 receptor and inhibiting the D2 receptor [27]. Parkinson's Disease which is manifest as a hypokinetic disorder is, in part, related to this loss of increased activity to the direct pathway following degeneration of the dopaminergic neurons in the zona compacta. Using this as an example, other pathways that connect and enhance one receptor over the other is a way to functionally bias complementary pathways. We can understand the direct pathway as a behavioral activating pathway and the indirect as the behavioral inhibiting pathway [28]. This description can also be applied to the two cerebral hemispheres and their role in behavioral control. The left hemisphere is thought to promote approach behaviors [29,30], motor activity [24], intention [29] and positive emotions [30]. The right hemisphere is thought to promote withdrawal behavior [29], sensory and attentional activity [29], and negative affect [29]. The left hemisphere promotes motor and increases behavioral activity and motivation while the right hemisphere is known to do the opposite [29]. Therefore it is reasonable to assume that when utilizing top-down control, the two cerebral hemispheres may differentially enhance or inhibit motor activity and cognitive behavior.

The premotor areas and frontal eye fields increase volitional as well as involitional motor activity and saccadic eye movements [31], the left orbital frontal cortex increases social motivation and awareness [29], the left dorsal lateral prefrontal cortex increases executive and cognitive function [24,30], while the left anterior cingulate increases motivation [29]. The right hemisphere decreases or inhibits those same pathways [32]. This would give even greater top-down control over these behaviors and it would make sense that this is done by enhancing the direct or indirect pathway.

The left hemisphere would promote and increase movement and behavior by selectively increasing the direct pathways perhaps by favoring the D1 receptors in the caudate and or putamen. The right hemisphere could promote the indirect pathway function by selectively

enhancing or stimulating the D2 receptors in these same areas. Since many of the hyperkinetic disorders like ADHD, Tourette's and OCD have all been associated with a decreased function of the right hemisphere and an increased function of left hemisphere activity [24,33,34] that would also seem to fit with the argument that a decrease in right hemisphere function would be associated with an increase in left hemisphere function and enhancement of the direct pathway and the D1 receptor promoting hyperkinetic movement and behaviors.

The right hemisphere could also have stronger connections to the subthalamic nucleus of Luys which would also enhance the indirect pathway whereas stronger left hemisphere connections to the caudate and putamen may also enhance direct pathway activation over indirect [14]. There are other receptors that could be selectively targeted by one hemisphere more than the other. The hemispheres are well documented to have this type of differential top-down control over other functions such as the immune system [35], autonomic system [30] as well as top down control of sensory processing at the thalamic level with cortico-thalamic fibers outnumbering thalamocortical fibers by a 10 – 1 ratio [36].

The recent discovery of a hyperdirect pathway [37] confirms that this hemispheric relationship exists and in fact it seems to affect both pathways as we described. The right hemisphere generally is known to be more involved with behavioral inhibition whereas the left hemisphere generally is involved in behavioral excitation. This effect in part seems to be due to the relationship between the cortex, and the prefrontal cortex and basal ganglia. The five primary loops from the frontal lobe to the basal ganglia as we described include the premotor cortex for movement, the orbital frontal cortex for social behavior, the dorsolateral prefrontal cortex controls executive function, the anterior cingulate regulates motivation, and the frontal eye fields control saccadic eye movements. Together these loops help to regulate all human behaviors. The left hemisphere control appears to have an excitatory influence whereas the right hemisphere seems to subserve primarily an inhibitory control of these functions. This appears to mainly be accomplished by the hyperdirect pathway of the right hemisphere. The hyperdirect pathway accomplishes this through its influence on the D2 receptor which initiates the indirect pathway. This pathway increases the inhibitory output of the GPi and its influence on the thalamic relay nuclei.

The second way that the right hemisphere exerts this inhibitory control is through the hyperdirect connection from the inferior frontal gyrus directly through an excitatory glutamatergic connection to the subthalamic nucleus of Luys. This increases the output of excitatory connections to the Gpi and an inhibitory connection to the GPe, which is inhibitory to the SNL. This also activates the indirect pathway increasing the inhibitory output of the GPi to the thalamus. Without this activity, the left hemisphere will have a relatively increased output to the D1 receptor activating the direct pathway, which decreases the output of the GPi through its inhibitory GABAergic connections. This, in turn, decreases the inhibition of the thalamic nuclei thereby increasing activity in these prefrontal loops. The clinical implications of this are significant especially in functional lesions of the brain where there are no anatomic lesions but rather a primary imbalance between the direct and indirect pathways.

A functional imbalance and/or a functional disconnection between the two hemispheres, that may be the result of an activation imbalance in the cortex between the two hemispheres, can lead to an imbalance in these loops producing either hyperkinetic or hypokinetic disorders. This would explain why symptoms of hyperkinetic disorders like ADHD also seem to be associated with a decrease in many right hemisphere functions along with relative increases in left hemisphere functions. This also would mean that therapeutically increasing the activation through target stimulation to one hemisphere and possibly to one or more dysfunctional basal ganglionic loops may help to restore a balance and temporal coherence between the hemispheres and between the direct and indirect loops.

For instance if someone is experiencing symptoms of OCD they have obsessions and compulsions in the absence of a specific lesion in the basal ganglia and specifically in the indirect pathway, this may be explained by decreased activation in the loops that involve the premotor cortex which control motor activity (compulsions) and the dorsolateral prefrontal cortex which controls executive functions, planning and behavior (obsessions) on the right hemisphere. This may result in a relative increase in those same loops on the left hemisphere leading to a relative increase of the direct pathway over the indirect pathway in those specific loops leading to OCD symptoms.

If this is the case then providing specific targeted stimulation to the premotor areas and the dorsolateral prefrontal cortex on the right hemisphere with the proper frequency, intensity and duration may produce an equilibration between the loops in those hemispheres and in the direct and indirect pathways. This may provide the best therapeutic option because it is specific, noninvasive and can provide long term correction which would be the ultimate goal.

5. Dynamic inter-regional effects

Disconnection syndromes were originally conceptualized as a disruption of communication between different cerebral cortical areas [30,31]. Schmahmann and Pandya [38] in an elegant review, indicate that the concept could be expanded. In overviewing their anatomical studies of monkeys, they found that efferent fibers emanate from every cortical area, and are directed with topographic precision via association fibers to ipsilateral cortical areas, commissural fibers to contralateral cerebral regions, striatal fibers to basal ganglia, and projection subcortical bundles to thalamus, brainstem and/or pontocerebellar system. They concluded that cortical areas are definable by their patterns of subcortical and cortical connections.

In applying their findings to humans, they note that motor, cognitive and neuropsychiatric disorders in patients with basal ganglia lesions, as well as those of the thalamus, or cerebellum, tend to mimic deficits resulting from cortical lesions, with qualitative differences between the manifestations of lesions in functionally related areas of cortical and subcortical nodes. These basal ganglia based behavioral conditions are viewed by Schmahmann and Pandya as disconnection syndromes reflecting loss of the contribution of subcortical nodes to the distributed neural circuits. They concluded that neural architecture

determines function, i.e., each architecturally distinct cortical and subcortical area contributes a unique transform, or computation, to information processing as suggested by Leisman and Melillo [30]. Anatomically precise and segregated connections between nodes define behavior and association fiber tracts that link cerebral cortical areas with each other enable the cross-modal integration required for evolved complex behaviors.

Co-contraction of muscle groups is realistically the co-activation of competing motor programs that serves as a fundamental mechanism used to achieve postural stabilization. Thus motor and cognitive signs associated with basal ganglionic lesions should also have a postural component that aids clinicians in the identification of lesions as well as providing a window for outcome observations when dealing with cognitive strategy efficacy.

The effective function involving the basal ganglia is traditionally thought to be achieved via a balance of excitation and inhibition of competing motor programs. In the context of this review, cognitive and motor functions need to be linked with postural control systems. These systems are known to be dynamic, rather than static. Hyperkinetic dystonias, for example, reflect excessive function of dynamic postures, rather than abnormal movements. Anne Blood [39] has suggested that the range of functional roles served by the postural system is hypothesized to include direct control of movement, suggesting a postural basis for task-specific dystonias. Further, by defining posture as a neural system that maintains body stabilization, it can be shown that the range of mechanical means of implementing stabilization, including co-contraction of antagonistic muscles, matches the range of presentations of dystonia reflecting abnormal integration in the basal ganglia. Inhibitory influences that stabilizing mechanisms exert on movement, suggest that the broad functional role of posture may be the function served by the indirect pathway of the basal ganglia. Specifically, the integrated pathway that centrally coordinates function of the distributed network of brain regions controlling posture and, in conjunction with the direct pathway, coordinates posture and movement. Postural systems are probably involved in cognition as well as the motor volitional and reflexogenic parameters of basal ganglionic influence. The involvement of posture in the basal ganglia and behavioral relationships is further supported by Marsden and Rothwell [41] who noted that co-contraction is realistically the co-activation of competing motor programs that serves as a fundamental mechanism used to achieve postural stabilization.

Numerous other investigators have recently begun to notice the relationship of posture to basal ganglia and cognitive function serving as a basis for the clinical discussions in the subsequent section. Mitra and colleagues [40] noted that the performance of a cognitive task while maintaining upright stance is associated with changes in body sway depending on tasks and experimental conditions. As increased sway is taken to indicate loosened postural control the precise impact of cognitive load on postural stability has remained unclear. These investigators noted that body sway increased during cognitive tasks while quiet standing but not while performing a visuo-postural alignment task suggesting that constraints placed on posture control by supra-postural task goals may significantly alter interactions between posture control and cognitive task.

Fujiwara and associates [42] investigated the effect of neck flexion on discriminative and cognitive processing in postural control during bilateral arm movement while standing, using event-related potential (ERP) and electromyogram. They noted significant positive correlations with neck flexion and P3 latency and anterior deltoid reaction time, and between N2 latency and the onset time of erector spinae, suggesting that with neck flexion, attention allocation to discriminative and cognitive processing increases, and the processing speed increases with shortening of reaction time in focal muscles.

Thus there is enough preliminary evidence to indicate that motor and cognitive signs associated with basal ganglionic lesions should also have a postural component that would aid clinicians in the identification of lesions as well as providing a window for outcome observations when dealing with cognitive strategy efficacy.

6. Clinical implications

It has been hypothesized that neuropsychiatric symptoms exhibited by patients with basal ganglia disorders are a consequence of an involvement of fronto-striatal connections. In addition to expressing contrasting motor dysfunction patterns, these disorders would also differ in the presenting psychiatric symptoms [10]. In this study patients with Huntington's disease (hyperkinetic) and Parkinson's disorder (hypokinetic) were observed to determine if they would present with hyperactive behavior (agitation, isolation, euphoria, or anxiety) and hypokinetic behavior (apathy) respectively. The results of this study demonstrated that patients with Huntington's (hyperkinetic) more frequently exhibited hyperactive behaviors such as agitation, irritability, euphoria, and anxiety whereas patients with Parkinson's (hypokinetic) frequently displayed hypoactive behavior (high levels of apathy). The investigators thought that in Huntington's, these behaviors result from excitatory subcortical output through the medial and orbito-frontal circuits to the pallidum, thalamus, and cortex as well as premotor and motor cortex. In contrast, patients with Parkinson's (hypoactive) in whom apathy is present were thought to demonstrate these behaviors as a consequence of hypo-stimulation of frontal subcortical circuits resulting from damage to several integrated nuclei (putamen, striatum and globus pallidus) [14,43,44].

It had been previously noted that patients with Huntington's and other hyperkinetic disorders like Tourette's exhibit mania, OCD, and intermittent explosive disorder [45,46-48]. PET studies of Huntington's patients without hyperactive behavior have shown frontal metabolism to be normal but with decreased caudate and putamen metabolism [49,50]. However it is thought that normal frontal metabolism in Huntington's may result from a coexistent neurological degeneration and the resultant thalamo-frontal hyper-stimulation. This may result in normal appearing frontal-cortical regional blood flow even when overt prefrontal type cognitive defects are manifested. This suggests that in this case, a dysfunctional prefrontal cortex may appear to be at baseline levels that appear normal when in fact the prefrontal cortices may be over stimulated by the thalamus. [51,52]. In fact, it was noted that with further atrophy of the caudate there was increased fronto-cortical metabolism while the patient performed cognitive tasks (set-shifting) and a greater increase

in cerebral metabolism over baseline. The poorer the subject performed on cognitive tasks, the greater the cortical activation. [51,52]. It has been speculated that in early Huntington's when there are no frontal lobe lesions, a relative balance between frontal and increased thalamic functions may explain behavioral symptoms [10].

PET scans of patients with Parkinson's have also provided support that frontal-subcortical connections are disrupted by subcortical dysfunction showing decreased glucose consumption in frontal cortex, and decrease nigrostriatal D2 receptor uptake ratios [53,54]. Researchers at Stanford University may have observed similar results in children with *ADHD* also known as childhood hyperkinetic disorder [55]. The Stanford study used functional MRI to image the brains of boys between the ages of 8 and 13 while playing a mental game. Ten of the boys were diagnosed with *ADHD* and six were considered normal. When the boys were tested there appeared to be a clear difference in the activity of the basal ganglia with the boys with *ADHD* having less activity in that area than the control subjects. After administering methylphenidate, the participants were scanned again and it was found that boys with *ADHD* had increased activity in the basal ganglia whereas the normal boys had decreased activity in the basal ganglia. Interestingly, the drug improved the performance of both groups to the same extent.

This may be a similar finding as the PET scans on patients with hyperactivity disorder, where normal appearing frontal metabolism existed with decreased caudate and putamen metabolism [56]. Methylphenidate, a dopamine reuptake inhibitor, may increase function in a previously dysfunctional basal ganglia whereas raising dopamine levels in normal individuals would most likely result in decreased activity of the basal ganglia to prevent overproduction of dopamine. The previously dysfunctional basal ganglia would have most likely resulted in decreased frontal metabolism with increased thalamo-cortical firing; this would result in decreased cognitive function with increased hyperkinetic (hyperactive) behavior. Increasing dopamine levels may increase frontal metabolism due to increased activity of the striatum with decreased firing of the globus pallidus thereby inhibiting thalamo-cortical firing decreases which in turn decreases hyperkinetic behavior. This would make sense based on the findings of fMRI before and after, and the fact that both groups showed equal improvement in performance.

7. Basal ganglia in obsessive compulsive disorder

Cognitive and brain maturational changes continue throughout late childhood and adolescence. During this time, increasing cognitive control over behavior enhances the voluntary suppression of reflexive/impulsive response tendencies [29,30]. We presently have the capacity to characterize changes in brain activity during cognitive development. Optimized top-down modulation of the ability to voluntarily suppress context-inappropriate behavior of reflexive acts is not fully developed until adulthood and this process provides a context to examine the nature of obsessive-compulsive disorder in a maturational context and within the framework of the basal ganglia and its networks.

The basal ganglia-thalamo-cortical circuits appear to play a modulating role in a wide range of behaviors. At the cortical level, given convergence upon specified regions within the frontal lobes, the behaviors in question would be those dependent upon the sensory-motor, premotor, frontal eye fields, and dorsolateral and orbito-frontal outflow targets. Processes such as the generation, maintenance, switching, and blending of motor, mental, or emotional sets would be involved. In disorders that primarily affect basal ganglia function, the planning and the execution of both motor and cognitive function within these behavioral domains could be affected. As we have seen, there is a high degree of diversity and complexity of activity within the basal ganglia. Despite the nature of the reverberating circuits, consequences of disruption will depend upon the site of the lesion and the associated interplay of neurochemical factors. For example, in the motor system, damage to various striatal circuitry levels can result in either hypo- or hyperkinetic disorders of movement. Following this analogy, it can be said that diverse lesions, depending on site, can result in problems with the development and maintenance of behavioral sets ("hypophrenic") versus problems in relinquishing preferential sets ("hyperphrenic"). In OCD, a "hyperphrenic" pattern would apply to those behaviors which are part of obsessional rituals.

There is evidence of basal ganglia dysfunction from imaging studies of OCD, with both reduced and increased volumes of caudate nuclei reported [57-59]. Increased caudate metabolism has been found to be reduced after effective treatment of the OCD [60,61 and in provoked or activated conditions, patients with OCD have shown increased caudate blood flow [62. Such imaging studies point to the importance of orbito-frontal-basal ganglia-thalamocortical circuits in the pathogenesis of OCD. In autism stereotyped, ritualistic and repetitive behaviors including compulsive rituals and difficulties in tolerating changes in routine or environment, are characteristic. It has been suggested [24,63,64] that these behaviors may share related pathophysiological mechanisms. Sears and colleagues [63] analyzed with high resolution MRI the volume of the bilateral caudate, putamen, and globus pallidus regions in a group with autism and a control group. No differences were detected in volumes of the globus pallidus or the putamen. Significant enlargement of 8 percent of the total caudate volume was found in the subjects with autism. This greater caudate volume was proportional to the increased total brain volume and enlargement of other brain structures earlier reported in the patients with autism. [65].

Based on the aforementioned studies and the basis of this chapter, the cortico-basal ganglia circuits linking the orbito-frontal and anterior cingulate cortex to the caudate nucleus might account for the cardinal features of OCD. All of these structures have been implicated in the evaluation of the significance of stimulating as positive or negative (rewarding or punishing) and all, as we have seen, have been linked to aspects of executive function. Cortical-basal ganglia circuits have been suggested to form a neuronal system critical for habit learning and for the routine performance of habits, and structures of the OCD circuit have specifically been implicated in the acquisition of stereotyped behaviors [66,67].

The basal ganglia are thought to exert control over action release through antagonistic "push-pull" output pathways, which serve to select intended actions [68]. As explained

earlier in the chapter, these functions are disrupted in hypokinetic disorders such as Parkinson's disease, in which action is diminished, and in the hyperkinetic disorders such as in Huntington's disease, in which action is excessive. Analogously, it has been suggested that the function of these cortico-basal ganglia pathways may also occur in some neuropsychiatric disorders including OCD and Tourette's syndrome.

Different sets of cortical-basal ganglia loops are thought to have specialized functions depending on the cortical areas participating in the loops. This organization may account for the symptom specificity of OCD as compared to other disorders of the basal ganglia and its pathways. For example, in Tourette's syndrome, in which the characteristics of actions are the predominant symptoms, the "motor loop" through the putamen is more effective than it is in OCD according to neuroimaging data [69-71]. In OCD, which typically involves obsessions as well as compulsive actions, the neuronal circuits interconnecting the orbito-frontal and anterior cingulate cortex with the basal ganglia are involved.

The caudate nucleus has been implicated in repetitive actions in monkeys. The orbital-frontal and the anterior cingulate cortex both project to the ventral part of the caudate nucleus and to the ventral striatum. In the monkey, these regions have been found to send outputs not only to the pallidum, but also to a large part of the dopamine-containing substantia nigra pars compacta, from which the nigro-striatal tract originates. The caudal orbito-frontal and anterior cingulate/caudal medial cortex are also a major source of input to the striosomal system in the head of the caudate nucleus. Striosomes in this region have been linked to reward effects and may appear to be differentially active under conditions in which the animals perform repetitive, stereotyped behaviors in response to dopamine receptor agonists [72].

These features of the orbito-frontal and anterior cingulate cortical-basal ganglia circuits are important not only for understanding OCD symptomatology, but also for understanding the developmental aspects of these disorders. The basal ganglia may influence of motor pattern generators in the brainstem as well as "cognitive pattern generators" in the cerebral cortex. The loops running from the neocortex to the basal ganglia and then to the thalamus and back to the neocortex may help to establish cognitive habits, just as they may influence the development of motor habits. If so, the cortical-basal ganglia loop dysfunction in OCD could reflect both sides of basal ganglia function, motor and cognitive, to bring about repetitive actions (compulsions) and repetitive thoughts (obsessions).

Alternatively, the basal ganglia may have as its task a process that takes input from cortical and other sources and releases the output as "chunks" in order to sequence behavior, important in forming coordinated, sequential motor actions and in developing streams of thoughts and motivation, and perhaps playing the violin [63]. The architecture of cortical-basal ganglia circuitry could support the smooth progression from a cognitive framework establishing priorities for potential behaviors to behavioral selection, thereby facilitating fluid and adaptive behavioral output. Dysfunction of this cortical-basal ganglia system could contribute to the symptoms of OCD. Individuals become stuck in a conceptual framework, unable to shift from one priority set to the next, and thus remain locked into a specific behavioral output program.

A large part of the frontal cortex receives inputs from the basal ganglia conveyed via the thalamus. These same cortical regions not only project to the basal ganglia (mainly to the striatum) but also to other regions including the thalamus. Cortical-thalamic loops are critical for integrative and optimized cortical functioning. The adequacy of basal ganglia function is necessary to facilitate associations among cortical inputs on the basis of context and evaluative signals, and thereby promote behavioral automation, normally necessary to reduce the information load on the system. The basal ganglia can relieve the frontal cortex of the substantial computational load in carrying out executive functions. With both cortical-thalamic and cortical-basal ganglia systems functioning under normal conditions, parallel processing can occur with the cortical-thalamic circuits supporting conscious (explicit) information processing and cortical-basal ganglia supporting automatic (implicit) processing functions. If cortical-basal ganglia pathways functioned abnormally, as in OCD such parallel processing capabilities would be compromised. Information normally processed automatically could intrude into the conscious domain of sessions, and behavioral selection could become narrowed to compulsive acts. Such dysfunction could contribute to the compelling nature of obsessions in OCD and to the stereotypic behaviors carried out as compulsions.

The cortical-basal ganglia circuits appear dysfunctional in OCD, but the mechanisms are not adequately understood at present. While we have seen that striatal lesions can induce intense compulsive behaviors and stereotypies, we have not as yet found the existence of subtle lesions of the striatum in OCD, perhaps as a result of the inadequacies of our current measuring instruments. Magnetic resonance spectroscopy studies have suggested that there exists reduced N-acetylaspartate levels within the striatum of persons with OCD, so that neuronal density there may actually be reduced [17,74]. Abnormal brain chemistry in OCD could affect neurotransmission in cortical-basal ganglia circuits leading to the abnormal metabolic activity seen in imaging studies indicated earlier. While little is known about neurochemistry of OCD, the most successful pharmacologic therapy for OCD is treatment with inhibitors of serotonin reuptake (SRIs) sites. Effective therapy with SRIs can reverse the abnormal metabolic activity seen in OCD circuits, suggesting that the modulatory effects of serotonin can act on the cortical-basal ganglia circuit defined in scanning studies [75].

Despite the clinical results, strong evidence of a primary serotonergic or other neurotransmitter abnormality in OCD is still lacking. One suggestion is that SRIs have their beneficial effects via downregulation of 5HT-1D autoreceptors within the orbito-frontal cortex [75]. Even though neuroimaging studies have pointed to cortico-basal ganglia circuits as being dysfunctional in OCD, it is still not clear what the functional abnormality is in the circuits in OCD and how they contribute to the expression of OCD symptoms. Nor is it clear how these circuits were normally, or help multiple loops of the system interconnecting cortex, thalamus, and basal ganglia actually operate. Improvements in the temporal and spatial resolution of imaging also now make it possible to follow the cascade of neuronal activity changes that occur during the evolution of OCD symptoms. It should be possible in the relatively near future to identify brain sites participating in the buildup of an obsession, the attendant anxiety, the escalation of an urge, the performance of a compulsion, and the resolution of the obsession and accompanying anxiety.

8. Basal ganglia in tourette's syndrome

Tourette's syndrome (TS) is a neurobehavioral disorder characterized by involuntary motor and vocal tics beginning in childhood [76]. Approximately 50 percent of individuals with TS also exhibit obsessive-compulsive disorder (OCD) in addition; tics and OCD individuals demonstrate similar features and both are thought to arise from frontal-cortical-basal ganglia-thalamo-cortical circuit dysfunction. Recent advances in understanding the neurobiology of TS come from neuroimaging, post-mortem, and from physiological and behavioral studies in human and non-human primates and rodents. These advances allow us to understand the nature of the complex dynamics of the basal ganglia pathways and how this disorder connects with other forms of cognitive dysfunction.

Tourette's syndrome is defined by motor and vocal tics that start during childhood, persist for more than one year, and fluctuate in type, frequency and anatomical distribution over time. A specific tic can be present for weeks, months or years and then suddenly cease. Other tics emerge and disappear with no predictable time course. The motor patterns of tics can involve individual muscles or small groups of muscles (simple tics), or more muscles acting in a coordinated pattern to produce movements that can resemble purposeful voluntary movements (complex tics). Many individuals with TS exhibit both simple and complex tics. Simple tics include eye blinking, nose twitching, head jerking, eye deviation, mouth opening, sniffing and throat clearing. Complex tics include head shaking, scratching, touching, throwing, hitting, gestures or uttering phrases. There is a tendency for tics to occur in 'bouts' that wax and wane over hours, days, weeks or months [77].

OCD is strongly associated with TS both within individuals with TS and within families [78]. As indicated above, OCD is characterized by repetitive thoughts that are involuntary, senseless and often associated with anxiety, coupled with repetitive ritualistic behaviors that are often performed in response to the premonitory thought or idea. There are striking similarities between tics and OCD, and it is sometimes difficult to distinguish complex tics from compulsions. Both tics and OCD include premonitory experiences such as sensations (tics) or thoughts (OCD) that precede involuntary repetitive movements (tics) or behaviors (OCD). Performance of the tic or compulsion typically terminates the premonitory symptoms, at least temporarily.

Another feature common to both phenomena but important for placing OCD and Tourette's within the cortico-basal ganglia loop process, is the impaired ability each disorder to inhibit unwanted actions [79,80]. The spectrum of simple tics, complex tics, and compulsions suggests that similar or shared pathophysiological mechanisms, but separate neural circuits, might underlie these phenomena. These overlaps can be seen in cases of poisoning especially with carbon monoxide in which the basal ganglia is selectively affected and symptoms have been reported not dissimilar from those of Tourette's syndrome [79].

It is useful for us to examine cursorily issues related the neuropharmacology of TS to better understand the nature of the loops and the connection of TS to OCD. Tics are suppressed reliably by dopamine antagonists and OCD is improved by selective serotonin-reuptake

inhibitors (SSRIs) [81]. These facts implicate the dopaminergic and serotonergic pathways and suggest the candidate loci for TS abnormalities. The implicated regions include the striatum, the substantia nigra, and the prefrontal cortices. The dopaminergic complex of the substantia nigra and ventral tegmental area and the serotonergic dorsal raphé nuclei both send major projections to the striatum. The striatum, prefrontal cortices and substantia nigra are further interlinked by a web of pathways that form the cortical–basal ganglia–thalamo–cortical circuits [82-85].

We can infer from the literature cited previously that TS is a disorder of the basal ganglia and its respective pathways in general, and a disorder of striatal organization and/or function in particular. Some correlative data from other disorders supports the idea that striatal dysfunction is involved in TS. Tics are seen also in disorders with known striatal pathology, such as Huntington’s disease [21,76]. Abundant data implicates ventral striatal dopaminergic neurotransmission in drug abuse and drug craving, attributes of which overlap with obsessive–compulsive disorder (OCD) [86].

The clinical presentation of TS should reflect involvement of striatal function. Tics, in general, are abnormal repetitive and stereotyped movements, but repetitive stereotyped behaviors also occur normally. These behavioral effects are consistent with the effects of D1 receptor agonists on the response of medium spiny striatal neurons to stimulation [87]. D1 agonists tend to potentiate the current state of striatal neurons and reinforce ongoing behaviors. The complex and perseverative behaviors caused by D1 agonists differ from the effects of D2 receptor agonists, which tend to cause simple repetitive stereotyped movements. Kelly and Berridge [86] suggest that super-stereotypy is analogous to complex tics or OCD. Other stereotyped behavioral sequences are modulated by the basal ganglia include complex defensive behaviors and facial movements.

Charles Darwin [88] had indicated that many facial movements are stereotyped among mammals and important in non-verbal communication. Because tics commonly involve involuntary head, neck and face movements, the importance of facial and related movements in social communication might explain the disruptive nature of tics. There are suggestions that regulation of socially relevant forms of communication is a phylogenetically ancient function of the basal ganglia.

Additionally, the basal ganglia participate in brain circuits responsible for habit formation and fixed action patterns [29]. Habits are physiological analogs of stereotyped, unconsciously executed behavioral sequences such as tics, obsessions and compulsions. The basal ganglia participate in circuits responsible for learning incremental stimulus–response associations epitomized by classical Pavlovian and instrumental conditioning [89]. Graybiel has emphasized that the basal ganglia might combine or ‘chunk’ individual stimulus–response associations into more complex behavioral sequences executed as stereotyped ‘units’ as we had seen earlier [68]. In addition, fMRI study of higher-order aversive conditioning, in which key computational strategy that humans use to learn predictions about pain was investigated. The investigators showed that neural activity in the ventral striatum and the anterior insula display marked correspondence to the signals for sequential

learning predicted by temporal difference models. They identified the ventral striatum as a key locus of such sequential learning [90]. Tics could represent a form of inappropriate habit formation in which inappropriate stimulus–response associations are formed. This interpretation might correlate with the fluctuating nature and ‘sensory’ component of tics.

In the study of non-human primates, electrophysiological studies of the intralaminar thalamic nuclei have revealed that these nuclei influence striatal attentional mechanisms and the processing of reward information [91]. These studies also suggest that intralaminar thalamic nuclei encode information complementary to the reward prediction error information provided by the dopaminergic nigrostriatal projection.

Basal ganglia circuitry models that we had described earlier in the paper view the normal, tonically active inhibitory output of the basal ganglia as a ‘brake’ on motor pattern generators (MPGs) in the cerebral cortex and brainstem [92]. For a desired movement controlled by a particular MPG, a specific set of striatal neurons is activated; these neurons inhibit basal ganglia output neurons in the GPi and substantia nigra pars reticulata (SNr) that project back, via the thalamus, to the cortical MPGs. The removal of tonic inhibition from the GPi and SNr (the ‘brake’) enables the desired motor pattern to proceed. In parallel, neurons in the subthalamic nucleus (STN) excite the surrounding majority of GPi and SNr output neurons. These surround neurons project via the thalamus to competing MPGs, increasing their inhibitory output and applying the “brake” to competing MPGs. The net result is facilitation of intended movement with inhibition of competing movements. In the generation of tics, it is hypothesized that an aberrant focus of striatal neurons becomes inappropriately active, causing unwanted inhibition of a group of basal ganglia output neurons, which in turn disinhibit an MPG leading to an involuntary movement. Repetitive over-activity of a given specific set of striatal neurons would result in repeated, stereotyped, unwanted movements [92]. Multiple tics would result from abnormal excessive activity of multiple discrete sets of striatal neurons. According to this hypothesis, each tic corresponds to the activity of a discrete set of striatal neurons [79].

9. Basal ganglia in ADHD

Attention-deficit/hyperactivity disorder is a highly heritable and prevalent neuropsychiatric disorder estimated to affect six percent of school-age children [24]. It is manifested by inattention, hyperactivity and impulsivity, which often respond substantially to treatment with methylphenidate or dextroamphetamine. Etiological theories suggest a deficit in cortico-striatal circuits, particularly those components modulated by dopamine and therefore discussed in comparison with the other basal ganglia related disorders in the paper. Teicher and colleagues [94] developed a functional magnetic resonance imaging procedure (T2 relaxometry) to indirectly assess blood volume in the striatum (caudate and putamen) of boys 6–12 years of age in steady-state conditions. Boys with attention-deficit/hyperactivity disorder had higher T2 relaxation time measures in the putamen bilaterally than healthy control subjects. Daily treatment with methylphenidate significantly changed the T2 relaxation times in the putamen of children with attention deficit/

hyperactivity disorder. There was a similar but non-significant trend in the right caudate. Teicher and colleagues concluded that attention-deficit/hyperactivity disorder symptoms may be closely tied to functional abnormalities in the putamen, which is mainly involved in the regulation of motor behavior.

Converging evidence implies the involvement of dopaminergic fronto-striatal circuitry in ADHD. Anatomical imaging studies using MRI have demonstrated subtle reductions in volume in regions of the basal ganglia and prefrontal cortex [e.g., 95]. Cognitive functioning is mildly impaired in this disorder [for review, see 90]. In particular, cognitive control, the ability to inhibit inappropriate thoughts and actions, is also affected and therefore we are again dealing with a disorder of inhibition. Several studies have shown that this impairment is related to the reduction in volume in fronto-striatal regions [96], and functional studies have suggested that older children and adults with ADHD may activate these regions less than controls during tasks that require cognitive control [e.g. 98, 99]. Durston et al. [100] showed that the development of this ability is related to the maturation of ventral fronto-striatal circuitry.

Volumetric abnormalities have also been associated with the basal ganglia and in turn with attention deficit hyperactivity disorder (ADHD). Qiu and colleagues [101], to specify localization of these abnormalities, employed large deformation diffeomorphic metric mapping (LDDMM) to examine the effects of ADHD, sex, and their interaction on basal ganglia shapes. The basal ganglia (caudate, putamen, globus pallidus) were manually delineated on magnetic resonance imaging from typically developing children and children with ADHD. LDDMM mappings from 35 typically developing children were used to generate basal ganglia templates. These investigators found that boys with ADHD showed significantly smaller basal ganglia volumes compared with typically developing boys, and LDDMM revealed the groups remarkably differed in basal ganglia shapes. Volume compression was seen bilaterally in the caudate head and body and anterior putamen as well as in the left anterior globus pallidus and right ventral putamen. Volume expansion was most pronounced in the posterior putamen. They concluded that the shape compression pattern of basal ganglia in ADHD suggests an atypical brain development involving multiple frontal-subcortical control loops, including circuits with premotor, oculomotor, and prefrontal cortices.

Aron and colleagues [102] brilliantly outlined the nature of inhibition in fronto-basal-ganglia networks relative to cognition. Their paper was not about the problems of ADHD individuals per se but a thorough analysis of the neurophysiology of stopping. They had indicated that sensory information about a stop signal is relayed to the prefrontal cortex, where the stopping command must be generated. They collected the evidence together indicating that the right inferior frontal cortex (IFC) is a critical region for stop signal response inhibition [103,104] with the most critical portion likely being the pars opercularis (Brodmann area 44) in humans. The right IFC can send a stop command to intercept the Go process via the basal ganglia (represented in Fig. 6b from Aron et al., [102]). The Go process is likely generated by premotor areas that project via the direct pathway of the basal ganglia (through striatum, pallidum, and thalamus), eventually exciting primary motor cortex and

generating cortico-spinal volleys to the relevant effector each interacting with the globus pallidus [105]. The Stop process could activate the globus pallidus via a projection from the subthalamic nucleus (STN). High resolution fMRI has shown activation of a midbrain region, consistent with the STN, when subjects successfully stop their responses [105], and diffusion tractography shows that this STN region is directly connected to the right IFC via a white matter tract [102] (Fig. 6c). Thus, once the Stop command is generated in frontal cortex, it could be rapidly conveyed to the basal ganglia via the so-called “hyperdirect pathway” to intercept the Go process in the final stages of the race. Two recent studies identified a third critical node for the stopping process in the dorso-medial frontal cortex, including the pre-supplementary motor area) [106,107].

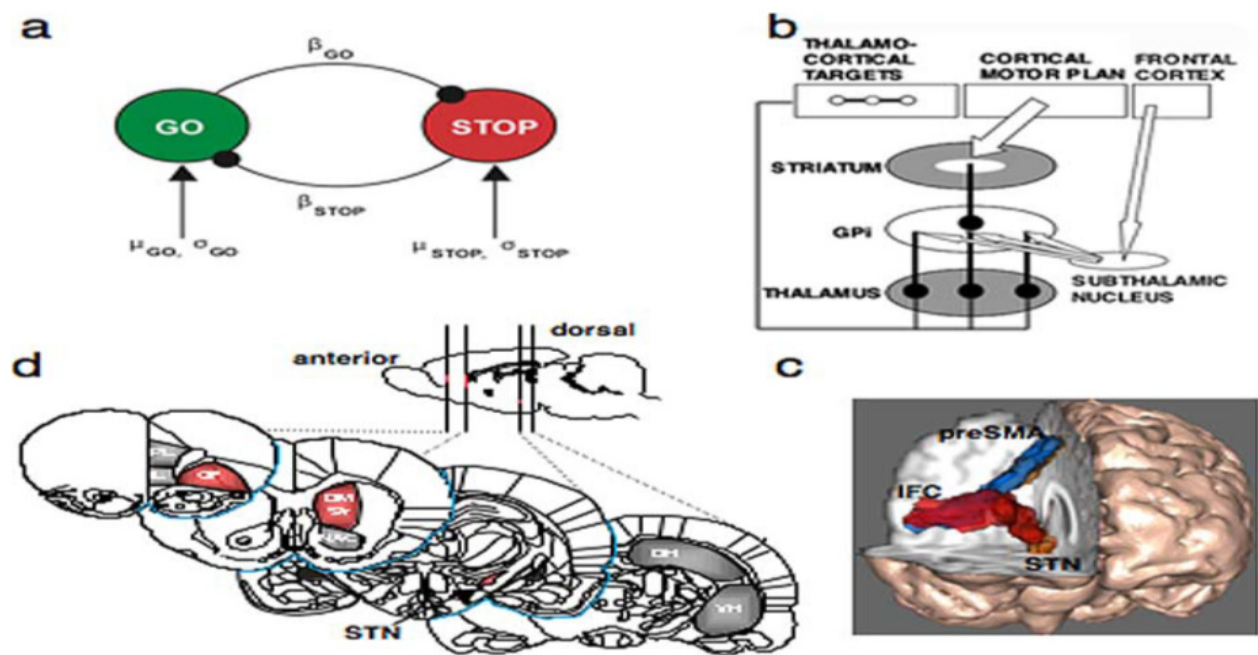

Figure 6. A, The interactive race model between Go and Stop processes [108]. The parameters were estimated by fitting the model to thousands of behavioral trials from a monkey neurophysiology study. B, Schematic of fronto-basal-ganglia circuitry for Going and Stopping. The Go process is generated by premotor cortex, which excites striatum and inhibits globus pallidus, removing inhibition from thalamus and exciting motor cortex (see text for details). The stopping process could be generated by inferior frontal cortex leading to activation of the subthalamic nucleus, increasing broad excitation of pallidum and inhibiting thalamocortical output, reducing activation in motor cortex. C, Diffusion-weighted imaging reveals putative white matter tracts in the right hemisphere between the dorsomedial preSMA, the ventrolateral PFC or IFC, and the putative region of the STN. Reproduced with permission from Aron et al. [102]. D, Regions of the rat brain implicated in behavioral stopping. Stopping is significantly impaired following excitotoxic lesions within the regions highlighted in red, whereas lesions within the gray-colored regions have no effect on stopping. OF, Orbitofrontal cortex; IL, infralimbic cortex; PL, prelimbic cortex; DM Str, dorsomedial striatum; NAC, nucleus accumbens (core); DH, dorsal hippocampus; VH, ventral hippocampus; GPi, globus pallidus pars interna. (From Aron et al. [102]),

10. Conclusions

Neural circuits linking activity in anatomically segregated populations of neurons in subcortical structures and the neocortex throughout the human brain regulate complex behaviors such as walking, talking, language comprehension and other cognitive functions including those associated with frontal lobes. Many neocortical and subcortical regions support the cortical-striatal-cortical circuits that confer various aspects of language ability, for example. However, many of these structures also form part of the neural circuits regulating other aspects of behavior. For example, the basal ganglia, which regulate motor control, are also crucial elements in the circuits that confer human linguistic ability and reasoning. The cerebellum, traditionally associated with motor control, is active in motor learning. The basal ganglia are also key elements in reward-based learning. Data from studies individuals with Tourette's syndrome, Obsessive-Compulsive Disorder as well as with Broca's aphasia, Parkinson's disease, hypoxia, focal brain damage, and from comparative studies of the brains and behavior of other species, demonstrate that the basal ganglia sequence the discrete elements that constitute a complete motor act, syntactic process, or thought process. Imaging studies of intact human subjects and electrophysiologic and tracer studies of the brains and behavior of other species confirm these findings. Dobzansky had stated, "Nothing in biology makes sense except in the light of evolution" (cited in [108]). That applies with as much force to the human brain and the neural bases of cognition as it does to the human foot or jaw. The converse follows: the mark of evolution on the brains of human beings and other species provides insight into the evolution of the brain bases of human language. The neural substrate that regulated motor control in the common ancestor of apes and humans most likely was modified to enhance cognitive and linguistic ability. Language and cognition played a central role in this process. However, the process that ultimately resulted in the human brain may have started when our earliest hominid ancestors began to walk.

Author details

Gerry Leisman

F.R. Carrick Institute for Clinical Ergonomics, Rehabilitation, and Applied Neurosciences, Garden City, New York USA

The National Institute for Brain and Rehabilitation Sciences, Nazareth, Israel

Nazareth Academic Institute, Nazareth, Israel

Biomedical Engineering, Dept. Biomechanics, ORT-Braude College of Engineering, Carmiel, Israel

Robert Melillo

F.R. Carrick Institute for Clinical Ergonomics, Rehabilitation, and Applied Neurosciences, Garden City, New York USA

The National Institute for Brain and Rehabilitation Sciences, Nazareth, Israel

Nazareth Academic Institute, Nazareth, Israel

Frederick R. Carrick

F.R. Carrick Institute for Clinical Ergonomics, Rehabilitation, and Applied Neurosciences, Garden City, New York USA

Carrick Institute for Graduate Studies, Cape Canaveral, Florida USA

Department of Neurology, Life University, Marietta, Georgia USA

Acknowledgement

This work was supported by the Ministry of Science of the State of Israel, the F., R. Carrick Research Institute, Inc., and Help the Hope Foundation.

11. References

- [1] Thatch W.T Jr (1980). The Cerebellum, In: Mount Casgle D.D, editor, Medical Physiology, 14th edition. St. Louis, MO: Mosby, 837-858.
- [2] Alexander G. E, DeLong M.R, Strick P.L (1986) Parallel Organization of Functionally Segregated Circuits Linking Basal Ganglia and Cortex. *Annu. rev. neurosci.* 9:357-381.
- [3] Alexander G.E, Crutcher M.D, DeLong M.R (1990) Basal Ganglia–Thalamocortical Circuits: Parallel Substrates for Motor, Oculomotor, (Prefrontal) and (Limbic) Functions. In: Uylungs H.B.N, Van Eben C.G, DeBruin J.P.C, Corner M.A, Feenstra M.G.P editors. *The Prefrontal Cortex, its Structure, Function, and Pathology.* Amsterdam, the Netherlands: Elsevier, 266-271.
- [4] Graybiel A.M (1995) Building action repertoires: memory and learning functions of the basal ganglia. *Curr Opin Neurobiol.*5(6):733-741.
- [5] Féger J (1997) Updating the Functional Model of the Basal Ganglia. *Trends neurosci.* 20(4):152-153.
- [6] Middleton, F.A, Strick P.L (2000) Basal Ganglia and Cerebellar Loops: Motor and Cognitive Circuits. *Brain res rev.* 31:236–250.
- [7] Chudler E.H, Dong W.K (1995) The Role of the Basal Ganglia in Nociception and Pain. *Pain.* 60(1):3-38.
- [8] Middleton F.A, Strick P.L (1994) Anatomical Evidence for Cerebellar and Basal Ganglia Involvement in Higher Cognitive Function. *Science.* 266:458-461.
- [9] Vitek JL, Giroux (2000) Physiology of Hypokinetic and Hyperkinetic Movement Disorders: Model for Dyskinesia. *Ann neurol.* 4(Suppl 1):S131-S140.
- [10] Litvan I, Paulsen J.S, Mega M.S, Cummings J.L (1998) Neuropsychiatric Assessment of Patients with Hyperkinetic and Hypokinetic Movement Disorders. *Arch neuro.* 55:1313-1319.
- [11] Stinear CM, Coxon JP, Byblow WD (2009) Primary Motor Cortex and Movement Prevention: Where Stop meets Go. *Neurosci bobehav rev.* 33(5):662-673.
- [12] Yakimovskii A.F, Varshavskaya V.M (2004) Neostriatal Glutamatergic System is Involved in the Pathogenesis of Picrotoxin-Induced Choreomyoclonic Hyperkinesia. *Bull exp biol med.* 138(6):533-536.

- [13] Kim J.M, Lee J.Y, Kim HJ, Kim JS, Kim YK, Park SS, Kim SE, Jeon BS (2010) The Wide Clinical Spectrum and Nigrostriatal Dopaminergic Damage in Spinocerebellar Ataxia Type 6. *J neurol neurosurg psychiatry*. 81(5):529-32.
- [14] Lanska D.J (2010) The History of Movement Disorders. *Handb clin neurol*. 95:501-546.
- [15] Cummings J.L, Diaz C, Levy M, Binetti G, Litvan I (1996) Neuropsychiatric Syndromes in Neurodegenerative Disease: Frequency and Significance. *Semin clin neuropsychiatry*. 1(4):241-247.
- [16] Litvan I, Mega M.S, Cummings J.L, Fairbanks L. (1996) Neuropsychiatric Aspects of Progressive Supranuclear Palsy. *Neurol*. 47(5):1184-1189.
- [17] Fitzgerald K.D, Welsh R.C, Stern E.R, Angstadt M, Hanna G.L, Abelson J.L, Taylor S.F (2011) Developmental Alterations of Frontal-Striatal-Thalamic Connectivity in Obsessive-Compulsive Disorder. *J am acad child adolesc psychiatry*. 50(9):938-948.
- [18] Gonçalves Ó.F, Carvalho S, Leite J, Pocinho F, Relvas J, Fregni F. (2011) Obsessive Compulsive Disorder as a Functional Interhemispheric Imbalance at the Thalamic Level. *Med hypotheses*. 77(3):445-447.
- [19] van den Heuvel O.A, Mataix-Cols D, Zwitser G, Cath D.C, van der Werf Y.D, Groenewegen H.J, van Balkom A.J, Veltman D.J (2011) Common Limbic and Frontal-Striatal Disturbances in Patients with Obsessive Compulsive Disorder, Panic Disorder and Hypochondriasis. *Psychol med*. 41(11):2399-410.
- [20] Chiu CH, Lo YC, Tang HS, Liu IC, Chiang WY, Yeh FC, Jaw FS, Tseng WY. (2011) White matter abnormalities of fronto-striato-thalamic circuitry in obsessive-compulsive disorder: A study using diffusion spectrum imaging tractography. *Psychiatry Res*. Jun 30;192(3):176-82.
- [21] Wang Z, Maia T.V, Marsh R, Colibazzi T, Gerber A, Peterson B.S (2011) The Neural Circuits that Generate Tics in Tourette's Syndrome. *Am j psychiatry*. 168(12):1326-37.
- [22] Du Y, Wu X, Li L (2011) Differentially Organized Top-Down Modulation of Prepulse Inhibition of Startle. *J neurosci*. 31(38):13644-13653.
- [23] Jahfari S, Waldorp L, van den Wildenberg W.P, Scholte H.S, Ridderinkhof K.R, Forstmann B.U (2011) Effective Connectivity Reveals Important Roles for Both the Hyperdirect (Fronto-Subthalamic) and the Indirect (Fronto-Striatal-Pallidal) Fronto-Basal Ganglia Pathways During Response Inhibition. *J neurosci*. 31(18):6891-6899.
- [24] Melillo R, Leisman G (2009a). *Neurobehavioral Disorders of Childhood: An Evolutionary Approach*, New York, NY: Springer.
- [25] Nambu A, Chiken S, Shashidharan P, Nishibayashi H, Ogura M, Kakishita K, Tanaka S, Tachibana Y, Kita H, Itakura T (2011) Reduced Pallidal Output Causes Dystonia. *Front syst neurosci*. 5:89.
- [26] Vitek J.L, Zhang J, Hashimoto T, Russo G.S, Baker K.B (2012) External Pallidal Stimulation Improves Parkinsonian Motor Signs and Modulates Neuronal Activity Throughout the Basal Ganglia Thalamic Network. *Exp neurol*. 233(1):581-586.
- [27] Mendoza J.E, Foundas A.F (2008) *Clinical Neuroanatomy: A Neurobehavioral Approach*, New York, NY: Springer, 2008, pp. 153-193.

- [28] Kalva S.K, Rengaswamy M, Chakravarthy V.S, Gupte N (2012) On the Neural Substrates for Exploratory Dynamics in Basal Ganglia: A Model. *Neural netw.* 2012 Feb 14. [Epub ahead of print]
- [29] Leisman G, Machado C, Melillo R, Mualem R (2012) Intentionality and 'Free-Will' From a Neurodevelopmental Perspective. *Front integr neurosci.* 2012 [In Press].
- [30] Leisman G, Melillo R (2012) The Development of the Frontal Lobes in Infancy and Childhood: Asymmetry and the Nature of Temperament and Adjustment. In: Cavanna, A.E editor. *Frontal Lobe: Anatomy, Functions and Injuries.* Hauppauge, NY: Nova Scientific Publishers.
- [31] Leisman G (1976) The Role of Visual Processes in Attention and its Disorders. In: Leisman G editor *Basic Visual Processes and Learning Disability.* Springfield, Il: Charles C. Thomas, 7-123.
- [32] Ridding M.C, Sheean G, Rothwell J.C, Inzelberg R, Kujirai T (1995) Changes in the Balance Between Motor Cortical Excitation and Inhibition in Focal, Task Specific Dystonia. *J neurol neurosurg psychiatry.* 59(5):493-8.
- [33] Wolosin S.M, Richardson M.E, Hennessey J.G, Denckla M.B, Mostofsky S.H (2009) Abnormal Cerebral Cortex Structure in Children with ADHD. *Hum brain mapp.* 30(1):175-184.
- [34] Lee J.S, Kim B.N, Kang E, Lee D.S, Kim Y.K, Chung J.K, Lee M.C, Cho S.C (2005) Regional Cerebral Blood Flow in Children with Attention Deficit Hyperactivity Disorder: Comparison Before and After Methylphenidate Treatment. *Hum brain mapp.* 24(3):157-164.
- [35] Kang D-H, Davidson R.J, Coe C.L, Wheeler R.E, Tomarken A.J, Ershler W.B (1991) Frontal Brain Asymmetry and Immune Function. *Behav neurosci.* 105(6):860-869.
- [36] Bal T, Debay D, Destexhe A (2000) Cortical Feedback Controls the Frequency and Synchrony of Oscillations in the Visual Thalamus. *J neurosci.* 20(19):7478-7488.
- [37] Aron AR, Poldrack RA (2006). Cortical and subcortical contributions to Stop signal response inhibition: role of the subthalamic nucleus. *J neurosci.* 26(9):2424-2433.
- [38] Schmahmann JD, Pandya DN. (2008). Disconnection Syndromes of Basal Ganglia, Thalamus, and Cerebrocerebellar Systems. *Cortex.* 44(8):1037-1066.
- [39] Blood AJ. (2008) New Hypotheses About Postural Control Support The Notion that all Dystonias are Manifestations of Excessive Brain Postural Function. *Biosci Hypotheses.* 1(1):14-25.
- [40] Marsden CD, Rothwell JC. (1987). The Physiology of Idiopathic Dystonia. *Can J Neurol Sci.* 14(3 Suppl):521-527.
- [41] Mitra S, Knight A, Munn A. (2012). Divergent Effects of Cognitive Load on Quiet Stance and Task-Linked Postural Coordination. *J Exp Psychol Hum Percept Perform.* Nov 5. [Epub ahead of print]
- [42] Fujiwara K, Yaguchi C, Kunita K, Mammadova A. (2012) Effects of neck flexion on discriminative and cognitive processing in anticipatory postural control during bilateral arm movement. *Neurosci Lett.* 518(2):144-148.

- [43] Litvan I, Mohr E, Williams J, Gomez C, Chase T.N (1991) Differential memory and executive functions in demented patients with Parkinson's and Alzheimer's disease. *J neurol. neurosurg psychiat.* 54(1):25-29.
- [44] Zeef D.H, Vlamings R, Lim L.W, Tan S, Janssen M.L, Jahanshahi A, Hoogland G, Prickaerts J, Steinbusch H.W, Temel Y (2012) Motor and Non-motor Behaviour in Experimental Huntington's Disease. *Behav brain res.* 226(2):435-439.
- [45] Cummings J.L, Cunningham K. (1992) Obsessive-Compulsive Disorder in Huntington's Disease. *Biol psychiatry.* 31(3):263-270.
- [46] Cummings J.L (1993) Frontal-Subcortical Circuits and Human Behavior. *Arch neurol.* 50(8):873-880.
- [47] Coffey B.J, Miguel E.C, Biederman J, Baer L, Rauch S.L, O'Sullivan R.L, Savage C.R, Phillips K, Borgman A, Green-Leibovitz M.I, Moore E, Park K.S, Jenike M.A (1998) Tourette's Disorder with and without Obsessive-Compulsive Disorder in Adults: Are they Different? *J nerv ment dis.* 186(4):201-6.
- [48] Beaulieu J.M, Gainetdinov R.R (2011) The Physiology, Signaling, and Pharmacology of Dopamine Receptors. *Pharmacol rev.* 63(1):182-217.
- [49] Sturrock A, Laule C, Decolongon J, Dar Santos R, Coleman A.J, Creighton S, Bechtel N, Reilmann R, Hayden M.R, Tabrizi S.J, Mackay A.L, Leavitt B.R. (2010) Magnetic Resonance Spectroscopy Biomarkers in Premanifest and Early Huntington Disease. *Neurology.* 75(19):1702-1710.
- [50] Grahn J.A, Parkinson J.A, Owen A.M. (2009) The Role of the Basal Ganglia in Learning and Memory: Neuropsychological Studies. *Behav brain res.* 199(1):53-60.
- [51] Gomez-Tortosa E, Arias-Navalon J.A, Barrio-Alba A, Barroso F.T, Pardo Pardo C, Sánchez Martín J.A, García Yébenes J (1996) Relation Between Frontal Lobe Blood Flow and Cognitive Performance in Huntington's Disease. *Neurologia.* 11, 251-256.
- [52] Weinberger D.R, Berman K.F, Ladarola N, Driesen N, Zec R.F (1988) Free Frontal Cortical Blood Flow and Cognitive Function in Huntington's Disease. *J neurol neurosurg psychiatry.* 51, 94-104.
- [53] Brooks D.J, Turjanski N, Sawle G.V, Playford E.D, Lees A.J (1992) PET Studies of the Integrity of the Pre and Postsynaptic Dopaminergic System in Tourette Syndrome. *Adv neurol.* 58:227–231.
- [54] Brooks D.J (1993) PET Studies on the Early and Differential Diagnosis of Parkinson's Disease. *Neurology.* 43(12 Suppl 6):S6-S16.
- [55] Tamm L, Menon V, Ringel J, Reiss A.L (2004) Event-Related fMRI Evidence of Frontotemporal Involvement in Aberrant Response Inhibition and Task Switching in Attention-Deficit/Hyperactivity Disorder. *J am acad child adolesc psychiatry.* 43(11):1430-1440.
- [56] Bush G, Valera E.M, Seidman L.J (2005) Functional Neuroimaging of Attention-Deficit/Hyperactivity Disorder: A review and Suggested Future Directions *Biol psychiatry.* 57:1273–1284.
- [57] Zarei M, Mataix-Cols D, Heyman I, Hough M, Doherty J, Burge L, Winmill L, Nijhawan S, Matthews P.M, James A (2011) Changes in Gray Matter Volume and White Matter

- Microstructure in Adolescents with Obsessive-Compulsive Disorder. *Biol psychiatry*. 70(11):1083-1090.
- [58] Harrison B.J, Soriano-Mas C, Pujol J, Ortiz H, López-Solà M, Hernández-Ribas R, Deus J, Alonso P, Yücel M, Pantelis C, Menchon J.M, Cardoner N. (2009) Altered Corticostriatal Functional Connectivity in Obsessive-Compulsive dDsorder. *Arch gen psychiatry*. 66(11):1189-1200.
- [59] Maia T.V, Cooney R.E, Peterson B.S (2008) The neural bases of Obsessive-Compulsive Disorder in Children and Adults. *Dev psychopathol*. 20(4):1251-1283.
- [60] Schwartz J.M, Stoessel P.W, Baxter Jr. L.R, , Martin K.M, Phelps M.E (1996) Systematic Changes in Cerebral Glucose Metabolic Rate after Successful Behaviour Modification Treatment of Obsessive Compulsive Disorder. *Arch gen psychiatry*. 53:109–113.
- [61] Adams K.H, Hansen E.S, Pinborg L.H, Hasselbalch S.G, Svarer C, Holm S, Bolwig T.G, Knudsen G.M (2005) Patients with Obsessive-Compulsive Disorder have Increased 5-HT2A Receptor Binding in the Caudate Nuclei. *Int j neuropsychopharmacol*. 8(3):391-401.
- [62] Ho Pian K.L, van Megen H.J, Ramsey N.F, Mandl R, van Rijk P.P, Wynne H.J, Westenberg H.G (2005) Decreased Thalamic Blood Flow in Obsessive-Compulsive Disorder Patients Responding to Fluvoxamine. *Psychiatry res*. 138(2):89-97.
- [63] Sears L.L, Vest C, Mohamed S, Bailey J, Ranson B.J, Piven J (1999) An MRI Study of the Basal Ganglia in Autism. *Prog neuropsychopharmacol biol psychiatry*. 23:613–624.
- [64] Melillo R, Leisman G (2009) Autism Spectrum Disorder as Functional Disconnection Syndrome. *Rev neurosci*. 20:2,111-132.
- [65] Nordahl C.W, Lange N, Li D.D, Barnett L.A, Lee A, Buonocore M.H, Simon T.J, Rogers S, Ozonoff S, Amaral D.G (2011) Brain Enlargement is Associated with Regression in Preschool-Age Boys with Autism Spectrum Disorders. *Proc natl acad sci USA*. 108(50):20195-20200.
- [66] Howe M.W, Atallah H.E, McCool A, Gibson D.J, Graybiel A.M (2011) Habit Learning is Associated with Major Shifts in Frequencies of Oscillatory Activity and Synchronized Spike Firing in Striatum. *Proc natl acad sci USA*. 108(40):16801-16806.
- [67] Lingawi N.W, Balleine B.W (2012) Amygdala Central Nucleus Interacts with Dorsolateral Striatum to Regulate the Acquisition of Habits. *J neurosci*. 32(3):1073-1081.
- [68] Graybiel A.M, Rauch S.L (2000) Toward a neurobiology of Obsessive-Compulsive Disorder. *Neuron*. 28:343–347.
- [69] Tobe R.H, Bansal R, Xu D, Hao X, Liu J, Sanchez J, Peterson B.S (2010) Cerebellar Morphology in Tourette Syndrome and Obsessive-Compulsive Disorder. *Ann neurol*. 67(4):479-487.
- [70] Marsh R, Maia T.V, Peterson B.S (2009) Functional Disturbances within Frontostriatal Circuits Across Multiple Childhood Psychopathologies. *Am j psychiatry*. 166(6):664-74.
- [71] Amat J.A, Bronen R.A, Saluja S, Sato N, Zhu H, Gorman D.A, Royal J, Peterson BS. (2006) Increased Number of Subcortical Hyperintensities on MRI in Children and Adolescents with Tourette's Syndrome, Obsessive-Compulsive Disorder, and Attention Deficit Hyperactivity Disorder. *Am j psychiatry*. 163(6):1106-1108.

- [72] Canales J.J, Graybiel A.M (2000) A Measure of Striatal Function Predicts Motor Stereotypy. *Nat neurosci.* 3(4):377-383.
- [73] Fan Q, Tan L, You C, Wang J, Ross C.A, Wang X, Zhang T, Li J, Chen K, Xiao Z (2010) Increased N-Acetylaspartate/creatine Ratio in the Medial Prefrontal Cortex Among Unmedicated Obsessive-Compulsive Disorder Patients. *Psychiatry clin neurosci.* 64(5):483-490.
- [74] Matsunaga H, Hayashida K, Maebayashi K, Mito H, Kiriike N (2011) A Case Series of Aripiprazole Augmentation of Selective Serotonin Reuptake Inhibitors in Treatment-Refractory Obsessive Compulsive Disorder. *Int j psychiatry clin pract.* 15(4):263-269.
- [75] el Mansari M, Bouchard C, Blier P (1995) Alteration of Serotonin Release in the Guinea Pig Orbito-Frontal Cortex by Selective Serotonin Reuptake Inhibitors. Relevance to Treatment of Obsessive-Compulsive Disorder. *Neuropsychopharmacol.* 13(2):117-127.
- [76] Leckman J, Cohen D (1999) Tourette's Syndrome – Tics, Obsessions, Compulsions: Developmental Psychopathology and Clinical Care. New York: Wiley.
- [77] Peterson B, Leckman J.F (1998) A Functional Magnetic Resonance Imaging Study of Tic Suppression in Tourette Syndrome. *Arch gen psychiatry* 55, 326–333.
- [78] Cavanna A.E, Termine C (2012) Tourette Syndrome. *Adv exp med biol.* 724:375-383.
- [79] Mink J.W (2001) Basal Ganglia Dysfunction in Tourette's Syndrome: A New Hypothesis. *Pediatr neurol.* 25:190–198.
- [80] Pulst S.M, Walshe T.M, Romero J.A (1983) Carbon Monoxide Poisoning with Features of Gilles de la Tourette's Syndrome *Arch Neurol.* 40(7):443-444.
- [81] Pringsheim T, Doja A, Gorman D, McKinlay D, Day L, Billinghamurst L, Carroll A, Dion Y, Luscombe S, Steeves T, Sandor P. (2012) Canadian Guidelines for the Evidence-Based Treatment of Tic Disorders: Pharmacotherapy. *Can j psychiatry.* 57(3):133-143.
- [82] Gurevich E.V, Joyce J.N (1996) Comparison of [³H]paroxetine and [³H]cyanoimipramine for Quantitative Measurement of Serotonin Transporter Sites in Human Brain. *Neuropsychopharmacol.* 14, 309–323.
- [83] Van Bockstaele E.J, Cestari D.M, Pickel V.M (1994) Synaptic Structure and Connectivity of Serotonin Terminals in the Ventral Tegmental Area: Potential Sites for Modulation of Mesolimbic Dopamine Neurons. *Brain res.* 647, 307–322.
- [84] Lambe E.K, Krimer L.S, Goldman-Rakic P.S (2000) Differential Postnatal Development of Catecholamine and Serotonin Inputs to Identified Neurons in Prefrontal Cortex of Rhesus Monkey. *J neurosci.* 20:8780–8787.
- [85] Bolam, J.P., Hanley JJ, Booth PA, Bevan MD. (2000) Synaptic Organisation of the Basal Ganglia. *J anat.* 196:527–542.
- [86] Kelly A.E, Berridge K.C (2002) The Neuroscience of Natural Rewards: Relevance to Addictive Drugs. *J neurosci.* 22:3306–3311.
- [87] Nicola S.M, Surmeier J, Malenka R.C (2000) Dopaminergic Modulation of Neuronal Excitability in the Striatum and Nucleus Accumbens. *Annu rev. Neurosci.* 23:185–215.
- [88] Darwin C. (1998) *The Expression of the Emotions in Man and Animals*. In: Ekman P, editor New York: Oxford.
- [89] Packard M.G, Knowlton B (2002) Learning and Memory Functions of the Basal Ganglia. *Annu. rev Neurosci.* 25:563–593.

- [90] Seymour B, O'Doherty J.P, Dayan P, Koltzenburg M, Jones A.K, Dolan R.J, Friston K.J, Frackowiak R.S. (2004) Temporal Difference Models Describe Higher-Order Learning in Humans. *Nature*. 429(6992):664-667.
- [91] Minamimoto T, Hori Y, Kimura M (2005) Complementary Process to Response Bias in the Centromedian Nucleus of the Thalamus. *Science* 308:1798–1801.
- [92] Mink J.W (1996) The Basal Ganglia: Focused Selection and Inhibition of Competing Motor Programs. *Prog Neurobiol*. 50:381–425.
- [93] Albin R.L, Mink J.W (2006) Recent Advances in Tourette Syndrome Research. *Trends Neurosci*. 29:3:175-182.
- [94] Teicher M.H, Anderson C.M, Polcari A, Glod C.A, Maas L.C, Renshaw P.F. (2000) Functional Deficits In Basal Ganglia of Children with Attention-Deficit/Hyperactivity Disorder Shown with Functional Magnetic Resonance Imaging Relaxometry. *Nat Med*. 6(4):470-473.
- [95] Castellanos F.X, Lee P.P, Sharp W, Jeffries N.O, Greenstein D.K, Clasen L.S, Blumenthal J.D, James R.S, Ebens C.L, Walter J.M, Zijdenbos A, Evans A.C, Giedd J.N, Rapoport J.L (2002) Developmental Trajectories of Brain Volume Abnormalities in Children and Adolescents with Attention-Deficit/Hyperactivity Disorder. *JAMA*. 288(14):1740-1748.
- [96] Sergeant J.A, Geurts H, Oosterlaan J (2002) How Specific is a Deficit of Executive Functioning for Attention-Deficit/Hyperactivity Disorder? *Behav brain res*. 130:3–28.
- [97] Semrud-Clikeman M, Steingard RJ, Filipek P, Biederman J, Bekken K, Renshaw PF (2000) Using MRI to Examine Brain-Behavior Relationships in Males with Attention Deficit Disorder with Hyperactivity. *J am acad child adolesc psychiatry*. 39(4):477-84.
- [98] Bush G, Frazier J.A, Rauch S.L, Seidman L.J, Whalen P.J, Jenike M.A, Rosen B.R, Biederman J (1999) Anterior Cingulate Cortex Dysfunction in Attention-Deficit/Hyperactivity Disorder Revealed by FMRI and the Counting Stroop. *Biol psychiatry* 45:1542–1552.
- [99] Vaidya C.J, Austin G, Kirkorian G, Ridlehuber H.W, Desmond J.E, Glover G.H, Gabrielli J.D (1998) Selective Effects of Methylphenidate in Attention Deficit Hyperactivity Disorder: A Functional Magnetic Resonance Study. *Proc natl acad sci USA*. 95:14494–14499.
- [100] Durston S, Thomas K.M, Worden M.S, Yang Y, Casey B.J (2002) The Effect of Preceding Context on Inhibition: An Event-Related FMRI Study. *Neuroimage*. 16(2):449-453.
- [101] Qiu A, Crocetti D, Adler M, Mahone E.M, Denckla M.B, Miller M.I, Mostofsky S.H, (2009) Basal Ganglia Volume and Shape in Children With Attention Deficit Hyperactivity Disorder. *Am j psychiatry*. 166(1): 74–82.
- [102] Aron, A.R, Durston S, Eagle D.M, Logan G.D, Stinear C.M, Stuphorn V (2007) Converging Evidence for a Fronto-Basal-Ganglia Network for Inhibitory Control of Action and Cognition. *J neurosci*. 27(44):11860 –11864.
- [103] Aron A.R, Fletcher P.C, Bullmore E.T, Sahakian B.J, Robbins T.W (2003). Stop Signal Inhibition Disrupted by Damage to Right Inferior Frontal Gyrus in Humans. *Nat neurosci*. 6:115–116.

- [104] Chambers C.D, Bellgrove M.A, Stokes M.G, Henderson T.R, Garavan H, Robertson I.H, Morris A.P, Mattingley J.B (2006) Executive “Brake Failure” Following Deactivation of Human Frontal Lobe. *J Cogn Neurosci*. 18:444–455.
- [105] Aron A.R, Poldrack R.A (2006) Cortical and Subcortical Contributions to Stop Signal Response Inhibition: Role of The Subthalamic Nucleus. *J neurosci*. 26:2424 –2433.
- [106] Floden D, Stuss D.T (2006) Inhibitory Control is Slowed in Patients with Right Superior Medial Frontal Damage. *J cogn neurosci*. 18:1843–1849.
- [107] Nachev P, Wydell H, O’Neill K, Husain M, Kennard C (2007) The Role of The Pre-Supplementary Motor Area in the Control of Action. *NeuroImage*. 36 [Suppl 2]:T155–T163.
- [108] Mayr E (1982) *The Growth of Biological Thought. Diversity, Evolution, and Inheritance*. Cambridge, Mass.: Harvard University Press.