

We are IntechOpen, the world's leading publisher of Open Access books Built by scientists, for scientists

4,800

Open access books available

122,000

International authors and editors

135M

Downloads

Our authors are among the

154

Countries delivered to

TOP 1%

most cited scientists

12.2%

Contributors from top 500 universities



WEB OF SCIENCE™

Selection of our books indexed in the Book Citation Index
in Web of Science™ Core Collection (BKCI)

Interested in publishing with us?
Contact book.department@intechopen.com

Numbers displayed above are based on latest data collected.
For more information visit www.intechopen.com



Analytical Approach for Synthesis of Minimum L_2 -Sensitivity Realizations for State-Space Digital Filters

Shunsuke Yamaki, Masahide Abe and
Masayuki Kawamata

Additional information is available at the end of the chapter

<http://dx.doi.org/10.5772/52194>

1. Introduction

On the fixed-point implementation of digital filters, undesirable finite-word-length (FWL) effects arise due to the coefficient truncation and arithmetic roundoff. These FWL effects must be reduced as small as possible because such effects may cause serious degradation of characteristic of digital filters. L_2 -sensitivity is one of the evaluation functions which evaluate the coefficient quantization effects of state-space digital filters [1–14]. The L_2 -sensitivity minimization is quite beneficial technique for the synthesis of high-accuracy digital filter structures, which achieves quite low-coefficient quantization error.

To the L_2 -sensitivity minimization problem, Yan *et al.* [1] and Hinamoto *et al.* [2] proposed solutions using iterative calculations. Both of the solutions in [1] and [2] try to solve nonlinear equations by successive approximation. Their solutions do not guarantee that the L_2 -sensitivity surely converges to the minimum L_2 -sensitivity since their solutions are not analytical solutions. It is necessary to derive some analytical solutions to the L_2 -sensitivity minimization problem in order to guarantee that their conventional solutions surely derive the minimum L_2 -sensitivity.

This chapter presents analytical approach for synthesis of the minimum L_2 -sensitivity realizations for state-space digital filters. In Section 3, we derive closed form solutions to the L_2 -sensitivity minimization problem for second-order digital filters [12, 13]. This problem can be converted into the problem to find the solution to fourth-degree polynomial equation of constant coefficients, which can be algebraically solved in closed form. Next, we reveal that the L_2 -sensitivity minimization problem can be solved analytically for arbitrary

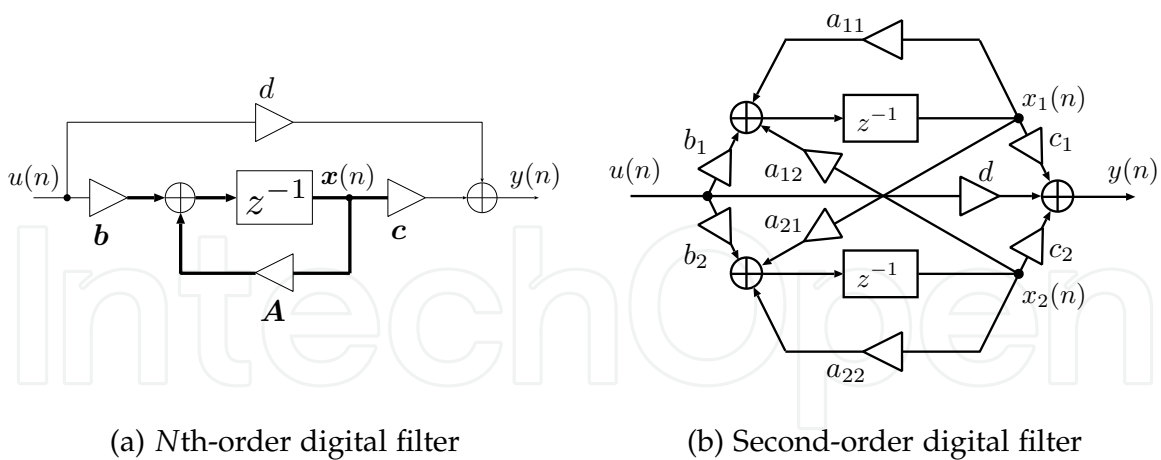

Figure 1. Block diagram of a state-space digital filter.

filter order if second-order modes are all equal [14] in Section 4. We derive a general expression of the transfer function of digital filters with all second-order modes equal. We show that the general expression is obtained by a frequency transformation on a first-order prototype FIR digital filter. Furthermore, we show the absence of limit cycles of the minimum L_2 -sensitivity realizations [11] in Section 5. The minimum L_2 -sensitivity realization without limit cycles can be synthesized by selecting an appropriate orthogonal matrix in the coordinate transformation matrix.

2. Preliminaries

This section gives the preliminaries in order to lay groundwork for the main topics of this chapter, which appear in later sections. In Subsection 2.1, we begin with introduction of state-space digital filters. Subsection 2.2 provides the introduction of L_2 -sensitivity. Subsection 2.3 explains coordinate transformations, the operation for changing the structures of state-space digital filters under the transfer function invariant. Subsection 2.4 formulates the L_2 -sensitivity minimization problem.

2.1. State-space digital filters

It is beneficial to introduce the state-space representation for the synthesis of high accuracy digital filters. For a given N th-order transfer function $H(z)$, a state-space digital filter can be described by the following state-space equations:

$$\mathbf{x}(n+1) = \mathbf{A}\mathbf{x}(n) + \mathbf{b}u(n) \quad (1)$$

$$y(n) = \mathbf{c}\mathbf{x}(n) + du(n) \quad (2)$$

where $\mathbf{x}(n) \in \mathfrak{R}^{N \times 1}$ is a state variable vector, $u(n) \in \mathfrak{R}$ is a scalar input, $y(n) \in \mathfrak{R}$ is a scalar output, and $\mathbf{A} \in \mathfrak{R}^{N \times N}$, $\mathbf{b} \in \mathfrak{R}^{N \times 1}$, $\mathbf{c} \in \mathfrak{R}^{1 \times N}$, $d \in \mathfrak{R}$ are real constant matrices called coefficient matrices. The block diagram of the state-space digital filter $(\mathbf{A}, \mathbf{b}, \mathbf{c}, d)$ is shown in Fig. 1(a). In case of second-order digital filters, the block diagram in Fig. 1(a) can be rewritten as shown in Fig. 1(b). The transfer function $H(z)$ is described in terms of the

coefficient matrices (A, b, c, d) as

$$H(z) = c(zI - A)^{-1}b + d. \quad (3)$$

In this chapter, the state-space representation (A, b, c, d) is assumed to be a minimal realization of $H(z)$, that is, the state-space representation (A, b, c, d) is controllable and observable. The transfer function $H(z)$ in Eq. (3) can be rewritten as

$$H(z) = c \frac{\text{adj}(zI - A)}{\det(zI - A)} b + d. \quad (4)$$

We know from the above equation that the poles of $H(z)$ are the solutions of the characteristic equation $\det(zI - A) = 0$, that is, the eigenvalues of the coefficient matrix A . Since we assume that the transfer function $H(z)$ is stable, all absolute values of the eigenvalues of the coefficient matrix A are less than unity. It follows from Eq. (4) that the absolute values of poles of $H(z)$ are less than unity.

2.2. L_2 -sensitivity

The L_2 -sensitivity is one of the measurements which evaluate coefficient quantization errors of digital filters. The L_2 -sensitivity of the filter $H(z)$ with respect to the realization (A, b, c, d) is defined by

$$\begin{aligned} S(A, b, c) &= \sum_{k=1}^N \sum_{l=1}^N \frac{1}{2\pi} \int_0^{2\pi} \left| \frac{\partial H(e^{j\omega})}{\partial a_{kl}} \right|^2 d\omega \\ &+ \sum_{k=1}^N \frac{1}{2\pi} \int_0^{2\pi} \left| \frac{\partial H(e^{j\omega})}{\partial b_k} \right|^2 d\omega + \sum_{l=1}^N \frac{1}{2\pi} \int_0^{2\pi} \left| \frac{\partial H(e^{j\omega})}{\partial c_l} \right|^2 d\omega \\ &= \left\| \frac{\partial H(z)}{\partial A} \right\|_2^2 + \left\| \frac{\partial H(z)}{\partial b} \right\|_2^2 + \left\| \frac{\partial H(z)}{\partial c} \right\|_2^2 \end{aligned} \quad (5)$$

where $\|\cdot\|_2$ denotes the L_2 -norm. The derivatives of the transfer function $H(z)$ with respect to the coefficient matrices are described by

$$\frac{\partial H(z)}{\partial A} = G^T(z)F^T(z), \quad \frac{\partial H(z)}{\partial b} = G^T(z), \quad \frac{\partial H(z)}{\partial c} = F^T(z) \quad (6)$$

where $F(z)$ and $G(z)$ are defined by

$$F(z) = (zI - A)^{-1}b \quad (7)$$

$$G(z) = c(zI - A)^{-1} \quad (8)$$

respectively. Substituting Eqs. (6) into Eq. (5), the L_2 -sensitivity can be rewritten as

$$\begin{aligned} S(\mathbf{A}, \mathbf{b}, \mathbf{c}) &= \left\| \frac{\partial H(z)}{\partial \mathbf{A}} \right\|_2^2 + \left\| \frac{\partial H(z)}{\partial \mathbf{b}} \right\|_2^2 + \left\| \frac{\partial H(z)}{\partial \mathbf{c}} \right\|_2^2 \\ &= \left\| \mathbf{G}^T(z) \mathbf{F}^T(z) \right\|_2^2 + \left\| \mathbf{G}^T(z) \right\|_2^2 + \left\| \mathbf{F}^T(z) \right\|_2^2. \end{aligned} \quad (9)$$

We can express the L_2 -sensitivity $S(\mathbf{A}, \mathbf{b}, \mathbf{c})$ by using complex integral as [1]

$$\begin{aligned} S(\mathbf{A}, \mathbf{b}, \mathbf{c}) &= \text{tr} \left[\frac{1}{2\pi j} \oint_{|z|=1} \mathbf{F}(z) \mathbf{G}(z) (\mathbf{F}(z) \mathbf{G}(z))^\dagger \frac{dz}{z} \right] \\ &\quad + \text{tr} \left[\frac{1}{2\pi j} \oint_{|z|=1} \mathbf{G}^\dagger(z) \mathbf{G}(z) \frac{dz}{z} \right] + \text{tr} \left[\frac{1}{2\pi j} \oint_{|z|=1} \mathbf{F}(z) \mathbf{F}^\dagger(z) \frac{dz}{z} \right]. \end{aligned} \quad (10)$$

Applying Parseval's relation to Eq. (10), Hinamoto *et al.* expressed the L_2 -sensitivity in terms of the general Gramians such as [2]

$$S(\mathbf{A}, \mathbf{b}, \mathbf{c}) = \text{tr}(\mathbf{W}_0) \text{tr}(\mathbf{K}_0) + \text{tr}(\mathbf{W}_0) + \text{tr}(\mathbf{K}_0) + 2 \sum_{i=1}^{\infty} \text{tr}(\mathbf{W}_i) \text{tr}(\mathbf{K}_i). \quad (11)$$

The general controllability Gramian \mathbf{K}_i and the general observability Gramian \mathbf{W}_i in Eq. (11) are defined as the solutions to the following Lyapunov equations:

$$\mathbf{K}_i = \mathbf{A} \mathbf{K}_i \mathbf{A}^T + \frac{1}{2} \left(\mathbf{A}^i \mathbf{b} \mathbf{b}^T + \mathbf{b} \mathbf{b}^T (\mathbf{A}^T)^i \right) \quad (12)$$

$$\mathbf{W}_i = \mathbf{A}^T \mathbf{W}_i \mathbf{A} + \frac{1}{2} \left(\mathbf{c}^T \mathbf{c} \mathbf{A}^i + (\mathbf{A}^T)^i \mathbf{c}^T \mathbf{c} \right) \quad (13)$$

for $i = 0, 1, 2, \dots$, respectively. The general controllability and observability Gramians are natural expansions of the controllability and observability Gramians, respectively. Letting $i = 0$ in Eqs. (12) and (13), we have the Lyapunov equations for the controllability Gramian \mathbf{K}_0 and the observability Gramian \mathbf{W}_0 as follows:

$$\mathbf{K}_0 = \mathbf{A} \mathbf{K}_0 \mathbf{A}^T + \mathbf{b} \mathbf{b}^T \quad (14)$$

$$\mathbf{W}_0 = \mathbf{A}^T \mathbf{W}_0 \mathbf{A} + \mathbf{c}^T \mathbf{c}. \quad (15)$$

The controllability Gramian \mathbf{K}_0 and the observability Gramian \mathbf{W}_0 are positive definite symmetric, and the eigenvalues θ_i^2 ($i = 1, \dots, N$) of the matrix product $\mathbf{K}_0 \mathbf{W}_0$ are all positive.

Second-order modes are defined by the square roots of the eigenvalues θ_i 's as follows [3, 5]:

$$(\theta_1, \dots, \theta_N) = \sqrt{\text{Eigenvalues of } K_0 W_0}. \quad (16)$$

In the field of digital signal processing, the controllability and observability Gramians are also called the covariance and noise matrices of the filter (A, b, c, d) , respectively.

2.3. Coordinate transformations

It is well known that the number of state-space realizations of a transfer function is infinite since choice of the state variable vector $x(n)$ is not unique. We can change the filter structures of state-space digital filters by the operation called *coordinate transformation* under the transfer function invariant.

Let T be a nonsingular $N \times N$ real matrix. If a coordinate transformation defined by

$$\bar{x}(n) = T^{-1}x(n) \quad (17)$$

is applied to a filter structure (A, b, c, d) , we obtain a new filter structure which has the following coefficient matrices:

$$(\bar{A}, \bar{b}, \bar{c}, \bar{d}) = (T^{-1}AT, T^{-1}b, cT, d). \quad (18)$$

It should be noted that the coordinate transformation does not affect the transfer function $H(z)$, that is,

$$\begin{aligned} \bar{H}(z) &= \bar{c}(zI - \bar{A})^{-1}\bar{b} + \bar{d} \\ &= c(zI - A)^{-1}b + d \\ &= H(z). \end{aligned} \quad (19)$$

It implies that there exist infinite filter structures for a given transfer function $H(z)$ since nonsingular $N \times N$ matrices exist infinitely. Therefore, one can synthesize infinite filter structures by the coordinate transformation with keeping the transfer function invariant.

Under the coordinate transformation by the nonsingular matrix T , the general controllability Gramian K_i and the general observability Gramian W_i are transformed into \bar{K}_i and \bar{W}_i given by

$$(\bar{K}_i, \bar{W}_i) = (T^{-1}K_i T^{-T}, T^T W_i T) \quad (20)$$

respectively. Letting $i = 0$ in Eqs. (20) yields

$$(\bar{\mathbf{K}}_0, \bar{\mathbf{W}}_0) = (\mathbf{T}^{-1}\mathbf{K}_0\mathbf{T}^{-T}, \mathbf{T}^T\mathbf{W}_0\mathbf{T}) \quad (21)$$

From Eqs. (21), we have

$$\bar{\mathbf{K}}_0\bar{\mathbf{W}}_0 = \mathbf{T}^{-1}\mathbf{K}_0\mathbf{W}_0\mathbf{T} \quad (22)$$

which shows that $\bar{\mathbf{K}}_0\bar{\mathbf{W}}_0$ has the same eigenvalues of $\mathbf{K}_0\mathbf{W}_0$. Thus, the second order modes defined by Eq. (16) are invariant under the coordinate transformations. It implies that second-order modes depends on only the transfer function.

2.4. L_2 -sensitivity minimization problem

The value of L_2 -sensitivity depends on not only the transfer function $H(z)$ but also the coordinate transformation matrix \mathbf{T} . The L_2 -sensitivity of the filter $(\mathbf{T}^{-1}\mathbf{A}\mathbf{T}, \mathbf{T}^{-1}\mathbf{b}, \mathbf{c}\mathbf{T}, d)$ can be expressed in terms of the complex integral as

$$\begin{aligned} S(\mathbf{T}^{-1}\mathbf{A}\mathbf{T}, \mathbf{T}^{-1}\mathbf{b}, \mathbf{c}\mathbf{T}) &= \text{tr} \left[\frac{1}{2\pi j} \oint_{|z|=1} \mathbf{T}^{-1}\mathbf{F}(z)\mathbf{G}(z)\mathbf{T}\mathbf{T}^T(\mathbf{F}(z)\mathbf{G}(z))^{\dagger}\mathbf{T}^{-T} \frac{dz}{z} \right] \\ &+ \text{tr} \left[\frac{1}{2\pi j} \oint_{|z|=1} \mathbf{T}^T\mathbf{G}^{\dagger}(z)\mathbf{G}(z)\mathbf{T} \frac{dz}{z} \right] + \text{tr} \left[\frac{1}{2\pi j} \oint_{|z|=1} \mathbf{T}^{-1}\mathbf{F}(z)\mathbf{F}^{\dagger}(z)\mathbf{T}^{-T} \frac{dz}{z} \right] \end{aligned} \quad (23)$$

or in terms of the general Gramians as

$$\begin{aligned} S(\mathbf{T}^{-1}\mathbf{A}\mathbf{T}, \mathbf{T}^{-1}\mathbf{b}, \mathbf{c}\mathbf{T}) &= \text{tr}(\mathbf{T}^T\mathbf{W}_0\mathbf{T})\text{tr}(\mathbf{T}^{-1}\mathbf{K}_0\mathbf{T}^{-T}) + \text{tr}(\mathbf{T}^T\mathbf{W}_0\mathbf{T}) + \text{tr}(\mathbf{T}^{-1}\mathbf{K}_0\mathbf{T}^{-T}) \\ &+ 2 \sum_{i=1}^{\infty} \text{tr}(\mathbf{T}^T\mathbf{W}_i\mathbf{T})\text{tr}(\mathbf{T}^{-1}\mathbf{K}_i\mathbf{T}^{-T}). \end{aligned} \quad (24)$$

The L_2 -sensitivity (23) can be expressed as the function of the positive definite symmetric matrix \mathbf{P} as follows [1]:

$$\begin{aligned} S(\mathbf{P}) &= \text{tr} \left[\frac{1}{2\pi j} \oint_{|z|=1} \mathbf{F}(z)\mathbf{G}(z)\mathbf{P}(\mathbf{F}(z)\mathbf{G}(z))^{\dagger}\mathbf{P}^{-1} \frac{dz}{z} \right] \\ &+ \text{tr} \left[\frac{1}{2\pi j} \oint_{|z|=1} \mathbf{G}^{\dagger}(z)\mathbf{G}(z)\mathbf{P} \frac{dz}{z} \right] + \text{tr} \left[\frac{1}{2\pi j} \oint_{|z|=1} \mathbf{F}(z)\mathbf{F}^{\dagger}(z)\mathbf{P}^{-1} \frac{dz}{z} \right] \end{aligned} \quad (25)$$

where $\mathbf{P} = \mathbf{T}\mathbf{T}^T$. Similarly, the L_2 -sensitivity (24) can be expressed as the function of the positive definite symmetric matrix \mathbf{P} as follows [2]:

$$S(\mathbf{P}) = \text{tr}(\mathbf{W}_0\mathbf{P})\text{tr}(\mathbf{K}_0\mathbf{P}^{-1}) + \text{tr}(\mathbf{W}_0\mathbf{P}) + \text{tr}(\mathbf{K}_0\mathbf{P}^{-1}) + 2 \sum_{i=1}^{\infty} \text{tr}(\mathbf{W}_i\mathbf{P})\text{tr}(\mathbf{K}_i\mathbf{P}^{-1}) \quad (26)$$

where $\mathbf{P} = \mathbf{T}\mathbf{T}^T$. The problem we consider here is to derive the optimal positive definite symmetric matrix \mathbf{P}_{opt} , which gives the global minimum of $S(\mathbf{P})$ as follows:

$$\left. \frac{\partial S(\mathbf{P})}{\partial \mathbf{P}} \right|_{\mathbf{P}=\mathbf{P}_{\text{opt}}} = \mathbf{0}. \quad (27)$$

If one can obtain the optimal positive definite symmetric matrix \mathbf{P}_{opt} , the optimal coordinate transformation matrix \mathbf{T}_{opt} is given by

$$\mathbf{T}_{\text{opt}} = \mathbf{P}_{\text{opt}}^{\frac{1}{2}} \mathbf{U} \quad (28)$$

where \mathbf{U} is an arbitrary orthogonal matrix. It implies that the minimum L_2 -sensitivity realizations exist infinitely for a given digital filter $H(z)$. The minimum L_2 -sensitivity realizations have freedom for orthogonal transformations.

3. Analytical solutions to the L_2 -sensitivity minimization problem for second-order digital filters

This section proposes analytical synthesis of the minimum L_2 -sensitivity realizations for second-order digital filters. We propose closed form solutions to the L_2 -sensitivity minimization problem of second-order state-space digital filters. The proposed closed form solutions can greatly save the computation time and guarantee that the L_2 -sensitivity obtained by the iterative algorithm of the conventional method surely converges to the theoretical minimum. We show that the L_2 -sensitivity is expressed by a simple linear combination of exponential functions, and we can obtain the minimum L_2 -sensitivity realization by solving a fourth degree polynomial equation of constant coefficients in closed form without iterative calculations [12, 13].

3.1. Problem formulation

We adopt the balanced realization $(\mathbf{A}_b, \mathbf{b}_b, \mathbf{c}_b, d_b)$ as the initial realization to synthesize the minimum L_2 -sensitivity realization. The coefficient matrices $(\mathbf{A}_b, \mathbf{b}_b, \mathbf{c}_b, d_b)$ satisfy symmetric properties as follows:

$$\mathbf{A}_b^T = \mathbf{\Sigma} \mathbf{A}_b \mathbf{\Sigma}, \quad \mathbf{c}_b^T = \mathbf{\Sigma} \mathbf{b}_b \quad (29)$$

where Σ is a signature matrix defined as follows:

$$\Sigma = \text{diag}(\sigma_1, \dots, \sigma_N), \sigma_i = \pm 1 \ (i = 1, \dots, N). \quad (30)$$

We exploit the symmetric properties of the balanced realization in order to simplify the L_2 -sensitivity formulation and minimization in the following discussion. Under this condition, the L_2 -sensitivity $S(P)$ in Eq. (26) is rewritten as

$$S(P) = \text{tr}(\mathbf{W}_0^{(b)} P) \text{tr}(\mathbf{K}_0^{(b)} P^{-1}) + \text{tr}(\mathbf{W}_0^{(b)} P) + \text{tr}(\mathbf{K}_0^{(b)} P^{-1}) + 2 \sum_{i=1}^{\infty} \text{tr}(\mathbf{W}_i^{(b)} P) \text{tr}(\mathbf{K}_i^{(b)} P^{-1}) \quad (31)$$

and thus, the L_2 -sensitivity minimization problem is formulated as follows:

$$\min_{\mathbf{P}} S(P) \text{ in Eq. (31)} \quad (32)$$

where P is an arbitrary positive definite symmetric matrix.

We derive the optimal positive definite symmetric matrix P_{opt} which gives the global minimum of the L_2 -sensitivity $S(P)$ in Eq. (31).

3.2. Second-order digital filters

Consider second-order digital filters with complex conjugate poles given by

$$H(z) = \frac{\alpha}{z - \lambda} + \frac{\alpha^*}{z - \lambda^*} + d \quad (33)$$

where (λ, λ^*) are *complex conjugate* poles, α is a *complex* scalar, and d is a *real* scalar¹. We define scalar parameters P , Q , and R as follows:

$$P = \frac{|\alpha|}{1 - |\lambda|^2} \quad (34)$$

$$R + jQ = \frac{\alpha}{1 - \lambda^2} \quad (35)$$

which can be calculated directly from the transfer function $H(z)$. The closed form expression of the balanced realization of the filter $H(z)$ is given as follows [15]:

$$\left[\begin{array}{c|c} \mathbf{A}_b & \mathbf{b}_b \\ \mathbf{c}_b & \mathbf{d}_b \end{array} \right] = \left[\begin{array}{cc|c} \lambda_r - \frac{\kappa - \kappa^{-1}}{2} \lambda_i & \frac{\kappa + \kappa^{-1}}{2} \lambda_i & \mu_1 + \mu_2 \\ -\frac{\kappa + \kappa^{-1}}{2} \lambda_i & \lambda_r + \frac{\kappa - \kappa^{-1}}{2} \lambda_i & \mu_1 - \mu_2 \\ \hline \mu_1 + \mu_2 & -(\mu_1 - \mu_2) & d \end{array} \right] \quad (36)$$

¹ For also second-order digital filters, we can derive analytical solutions to the L_2 -sensitivity minimization problem [13].

where

$$\begin{cases} \lambda = \lambda_r + j\lambda_i, \alpha = \alpha_r + j\alpha_i, \kappa = \sqrt{\frac{P+Q}{P-Q}}, \\ \mu_1 = \sqrt{\frac{\kappa(|\alpha| - \alpha_i)}{2}}, \mu_2 = \sqrt{\frac{|\alpha| + \alpha_i}{2\kappa}} \text{sign}(\alpha_r). \end{cases} \quad (37)$$

Using the parameters P, Q , and R , the controllability Gramian $K_0^{(b)}$ and the observability Gramian $W_0^{(b)}$ of the balanced realization (A_b, b_b, c_b, d_b) can be expressed as follows:

$$K_0^{(b)} = W_0^{(b)} = \Theta \quad (38)$$

$$\Theta = \text{diag}(\theta_1, \theta_2)$$

$$= \text{diag}(\sqrt{P^2 - Q^2} + R, \sqrt{P^2 - Q^2} - R). \quad (39)$$

3.3. Property of the positive definite symmetric matrix P

In this subsection, we consider the property of the positive definite symmetric matrix P . The following two theorems lead a symmetric property of the optimal positive definite symmetric matrix P_{opt} [1].

Theorem 1. [9] L_2 -sensitivity $S(P)$ has the unique global minimum, which is achieved by a positive definite symmetric matrix P_{opt} satisfying

$$\left. \frac{\partial S(P)}{\partial P} \right|_{P=P_{\text{opt}}} = \mathbf{0}. \quad (40)$$

□

Theorem 2. [1] If a positive definite symmetric matrix P_{opt} satisfies

$$\left. \frac{\partial S(P)}{\partial P} \right|_{P=P_{\text{opt}}} = \mathbf{0} \quad (41)$$

then the positive definite symmetric matrix $\Sigma P_{\text{opt}}^{-1} \Sigma$ also satisfies

$$\left. \frac{\partial S(P)}{\partial P} \right|_{P=\Sigma P_{\text{opt}}^{-1} \Sigma} = \mathbf{0} \quad (42)$$

for the signature matrix Σ which satisfies Eq. (29).

□

The derivative $\partial S(\mathbf{P})/\partial \mathbf{P}$ is given by differentiating $S(\mathbf{P})$ in Eq. (31) with respect to \mathbf{P} as

$$\begin{aligned} \frac{\partial S(\mathbf{P})}{\partial \mathbf{P}} = & (1 + \text{tr}(\mathbf{K}_0^{(b)} \mathbf{P}^{-1})) \mathbf{W}_0^{(b)} + 2 \sum_{i=1}^{\infty} \text{tr}(\mathbf{K}_i^{(b)} \mathbf{P}^{-1}) \mathbf{W}_i^{(b)} \\ & - \mathbf{P}^{-1} \left((1 + \text{tr}(\mathbf{W}_0^{(b)} \mathbf{P})) \mathbf{K}_0^{(b)} + 2 \sum_{i=1}^{\infty} \text{tr}(\mathbf{W}_i^{(b)} \mathbf{P}) \mathbf{K}_i^{(b)} \right) \mathbf{P}^{-1}. \end{aligned} \quad (43)$$

From Theorem 1 and Theorem 2, it is proved that the optimal positive definite symmetric matrix \mathbf{P}_{opt} has the following symmetric property [1]:

$$\mathbf{P}_{\text{opt}} = \mathbf{\Sigma} \mathbf{P}_{\text{opt}}^{-1} \mathbf{\Sigma} \quad (44)$$

for the signature matrix $\mathbf{\Sigma}$ which satisfies Eq. (29). We will thus search the optimal positive definite symmetric matrix \mathbf{P}_{opt} among the positive definite symmetric matrices \mathbf{P} which satisfy

$$\mathbf{P} = \mathbf{\Sigma} \mathbf{P}^{-1} \mathbf{\Sigma}. \quad (45)$$

3.4. Closed form expression of the positive definite symmetric matrix \mathbf{P}

In this subsection, we consider the case of second-order digital filters and give the closed form expression of the positive definite symmetric matrix \mathbf{P} . When we restrict ourselves to the second-order case of state-space digital filters, we can give an closed form expression of the positive definite symmetric matrix \mathbf{P} which satisfies Eq. (45), considering the form of the signature matrix $\mathbf{\Sigma}$ classified into the following two cases:

$$\begin{cases} \mathbf{\Sigma} = \pm \text{diag}(1, 1) = \pm \mathbf{I} \\ \mathbf{\Sigma} = \pm \text{diag}(1, -1). \end{cases} \quad (46)$$

For each case, we next consider the closed form expression of the positive definite symmetric matrix \mathbf{P} which satisfies Eq. (45).

In case of $\mathbf{\Sigma} = \pm \mathbf{I}$, Eq. (44) yields $\mathbf{P}_{\text{opt}} = \mathbf{P}_{\text{opt}}^{-1}$, that is, $\mathbf{P}_{\text{opt}} = \mathbf{I}$. It means that the minimum L_2 -sensitivity realization can be synthesized without any coordinate transformation to the balanced realization, that is, the initial realization. In other words, the minimum L_2 -sensitivity realization is the balanced realization as follows:

$$(\mathbf{A}_{\text{opt}}, \mathbf{b}_{\text{opt}}, \mathbf{c}_{\text{opt}}, d_{\text{opt}}) = (\mathbf{A}_b, \mathbf{b}_b, \mathbf{c}_b, d_b). \quad (47)$$

Thus, we need no more discussion on this case since the minimum L_2 -sensitivity realization is already achieved as the balanced realization.

On the other hand, in case of $\Sigma = \pm \text{diag}(1, -1)$, the authors have derived the closed form expression of a positive definite symmetric matrix P which satisfies Eq. (45) as follows:

$$P = \begin{bmatrix} \cosh(p) & \sinh(p) \\ \sinh(p) & \cosh(p) \end{bmatrix} \quad (48)$$

where p is a real scalar variable [12, 13].

3.5. Closed form expression of the L_2 -sensitivity $S(P)$

In this subsection, the closed form expression of the L_2 -sensitivity of second-order digital filters is given. We give the closed form expression of the L_2 -sensitivity $S(P)$ in Eq. (31). We first express the general Gramians of the balanced realization (A_b, b_b, c_b, d_b) as follows:

$$\begin{aligned} K_i^{(b)} &= \frac{1}{2} \left(A_b^i K_0^{(b)} + K_0^{(b)} (A_b^T)^i \right) \\ &= \frac{1}{2} \left(A_b^i \Theta + \Theta (A_b^T)^i \right) \end{aligned} \quad (49)$$

$$\begin{aligned} W_i^{(b)} &= \frac{1}{2} \left(W_0^{(b)} A_b^i + (A_b^T)^i W_0^{(b)} \right) \\ &= \frac{1}{2} \left(\Theta A_b^i + (A_b^T)^i \Theta \right). \end{aligned} \quad (50)$$

We express the L_2 -sensitivity $S(P)$ by substituting Eqs. (49) and (50) into Eq. (31) as follows:

$$S(P) = \text{tr}(\Theta P) \text{tr}(\Theta P^{-1}) + \text{tr}(\Theta P) + \text{tr}(\Theta P^{-1}) + 2 \sum_{i=1}^{\infty} \text{tr}(\Theta A_b^i P) \text{tr}(\Theta (A_b^T)^i P^{-1}). \quad (51)$$

The L_2 -sensitivity $S(P)$ in Eq. (51) can be expressed more simply. Exploiting the symmetric property of coefficient matrix A_b and P given in Eqs. (29) and (45) respectively, we can rewrite the L_2 -sensitivity $S(P)$ as

$$S(P) = 2\text{tr}(\Theta P) - (\text{tr}(\Theta P))^2 + 2 \sum_{i=0}^{\infty} \left(\text{tr}(\Theta A_b^i P) \right)^2. \quad (52)$$

In order to give the closed form expression of the L_2 -sensitivity $S(P)$ in Eq. (52), it is necessary to derive the closed form expressions of matrices A_b , Θ , and P . The closed form expressions of matrices A_b and Θ are given in Eqs. (36) and (39), respectively. The closed form expression of the positive definite symmetric matrix P is given in Eq. (48). Substituting the closed form expressions of matrices A_b , Θ , and P into Eq. (52) gives the closed form expression of the L_2 -sensitivity $S(p)$ as

$$S(P) = S(p) = \sum_{n=-2}^2 s_n e^{np}. \quad (53)$$

It is remarkable that Eq. (53) is a simple linear combination of exponential functions which does not contain infinite summations. These coefficients s_n 's are easily computed directly from the transfer function $H(z)$ [12, 13].

3.6. Synthesis of minimum L_2 -sensitivity realizations

The parameter p which minimizes $S(p)$ in Eq. (53) can be derived by solving the following equation with respect to p :

$$\frac{\partial S(p)}{\partial p} = \sum_{n=-2}^2 ns_n e^{np} = 0. \quad (54)$$

Letting $\beta = e^p$ gives

$$\sum_{n=-2}^2 ns_n \beta^n = 0. \quad (55)$$

The above equation is a fourth-degree polynomial equation with respect to β of constant coefficients. In 1545, G. Cardano states in his book entitled *Ars Magna* (its translated edition is [16]) that there exists the formula of solutions for fourth-degree polynomial equations. Therefore, Eq. (55) can be solved analytically. Eq. (55) has four solutions, from which the positive real solution $\beta_{\text{opt}} = e^{p_{\text{opt}}}$ is adopted to derive the optimal positive definite symmetric matrix \mathbf{P}_{opt} as

$$\begin{aligned} \mathbf{P}_{\text{opt}} &= \begin{bmatrix} \cosh(p_{\text{opt}}) & \sinh(p_{\text{opt}}) \\ \sinh(p_{\text{opt}}) & \cosh(p_{\text{opt}}) \end{bmatrix} \\ &= \frac{1}{2} \begin{bmatrix} \beta_{\text{opt}} + \beta_{\text{opt}}^{-1} & \beta_{\text{opt}} - \beta_{\text{opt}}^{-1} \\ \beta_{\text{opt}} - \beta_{\text{opt}}^{-1} & \beta_{\text{opt}} + \beta_{\text{opt}}^{-1} \end{bmatrix}. \end{aligned} \quad (56)$$

The diagonalization of the optimal positive definite symmetric matrix $\mathbf{P}_{\text{opt}} = \mathbf{T}_{\text{opt}} \mathbf{T}_{\text{opt}}^T$ is given by

$$\begin{aligned} \mathbf{P}_{\text{opt}} &= \begin{bmatrix} \frac{1}{\sqrt{2}} & -\frac{1}{\sqrt{2}} \\ \frac{1}{\sqrt{2}} & \frac{1}{\sqrt{2}} \end{bmatrix} \begin{bmatrix} \beta_{\text{opt}} & 0 \\ 0 & \beta_{\text{opt}}^{-1} \end{bmatrix} \begin{bmatrix} \frac{1}{\sqrt{2}} & \frac{1}{\sqrt{2}} \\ -\frac{1}{\sqrt{2}} & \frac{1}{\sqrt{2}} \end{bmatrix} \\ &\equiv \mathbf{R}^T \mathbf{B}_{\text{opt}} \mathbf{R}. \end{aligned} \quad (57)$$

Once the optimal positive definite symmetric matrix \mathbf{P}_{opt} is derived, the optimal coordinate transformation matrix \mathbf{T}_{opt} is calculated as

$$\mathbf{T}_{\text{opt}} = \mathbf{P}_{\text{opt}}^{\frac{1}{2}} \mathbf{U} \quad (58)$$

where \mathbf{U} is an arbitrary orthogonal matrix. We have to note that the optimal coordinate transformation matrix \mathbf{T}_{opt} is not unique because of the non-uniqueness of matrix \mathbf{U} . By letting $\mathbf{U} = \mathbf{I}$ in Eq. (58), for instance, one of the optimal coordinate transformation matrices $\mathbf{T}_{\text{opt}} = \mathbf{P}_{\text{opt}}^{1/2}$ is given by

$$\begin{aligned} \mathbf{T}_{\text{opt}} &= \mathbf{P}_{\text{opt}}^{\frac{1}{2}} \\ &= \mathbf{R}^T \mathbf{B}_{\text{opt}}^{\frac{1}{2}} \mathbf{R} \\ &= \begin{bmatrix} \frac{1}{\sqrt{2}} & -\frac{1}{\sqrt{2}} \\ \frac{1}{\sqrt{2}} & \frac{1}{\sqrt{2}} \end{bmatrix} \begin{bmatrix} \beta_{\text{opt}}^{\frac{1}{2}} & 0 \\ 0 & \beta_{\text{opt}}^{-\frac{1}{2}} \end{bmatrix} \begin{bmatrix} \frac{1}{\sqrt{2}} & \frac{1}{\sqrt{2}} \\ -\frac{1}{\sqrt{2}} & \frac{1}{\sqrt{2}} \end{bmatrix} \\ &= \frac{1}{2} \begin{bmatrix} \beta_{\text{opt}}^{\frac{1}{2}} + \beta_{\text{opt}}^{-\frac{1}{2}} & \beta_{\text{opt}}^{\frac{1}{2}} - \beta_{\text{opt}}^{-\frac{1}{2}} \\ \beta_{\text{opt}}^{\frac{1}{2}} - \beta_{\text{opt}}^{-\frac{1}{2}} & \beta_{\text{opt}}^{\frac{1}{2}} + \beta_{\text{opt}}^{-\frac{1}{2}} \end{bmatrix}. \end{aligned} \tag{59}$$

We can give a geometrical interpretation of the above optimal coordinate transformation matrix \mathbf{T}_{opt} . In Eq. (59), \mathbf{R} is an orthogonal matrix, which means $\pi/4$ [rad] rotation of the coordinate axes, \mathbf{B}_{opt} is a positive definite diagonal matrix, which means a simple scaling of each coordinate axis. Eq. (59) shows that the minimum L_2 -sensitivity realization is obtained by the following operations for the coordinate axes of the initial balanced realization; $-\pi/4$ [rad] rotation, simple scaling, and $+\pi/4$ [rad] rotation. Finally, the minimum L_2 -sensitivity realization ($\mathbf{A}_{\text{opt}}, \mathbf{b}_{\text{opt}}, \mathbf{c}_{\text{opt}}, d_{\text{opt}}$) is synthesized as follows:

$$\left[\begin{array}{c|c} \mathbf{A}_{\text{opt}} & \mathbf{b}_{\text{opt}} \\ \mathbf{c}_{\text{opt}} & d_{\text{opt}} \end{array} \right] = \left[\begin{array}{c|c} \mathbf{T}_{\text{opt}}^{-1} \mathbf{A}_b \mathbf{T}_{\text{opt}} & \mathbf{T}_{\text{opt}}^{-1} \mathbf{b}_b \\ \mathbf{c}_b \mathbf{T}_b & d_b \end{array} \right] \tag{60}$$

and the minimum L_2 -sensitivity S_{min} , which is achieved by $p_{\text{opt}} = \log(\beta_{\text{opt}})$, is expressed by substituting p_{opt} into Eq. (53) as

$$S_{\text{min}} = \sum_{n=2}^2 s_n \beta_{\text{opt}}^n. \tag{61}$$

3.7. Numerical examples

We present numerical examples to demonstrate the validity of the proposed method. Consider a second-order digital filter $H(z)$ with complex conjugate poles, of which transfer function is given by

$$\begin{aligned} H(z) &= \frac{\alpha}{z - \lambda} + \frac{\alpha^*}{z - \lambda^*} + d \\ &= \frac{0.0396 + 0.0793z^{-1} + 0.0396z^{-2}}{1 - 1.3315z^{-1} + 0.49z^{-2}} \end{aligned} \tag{62}$$

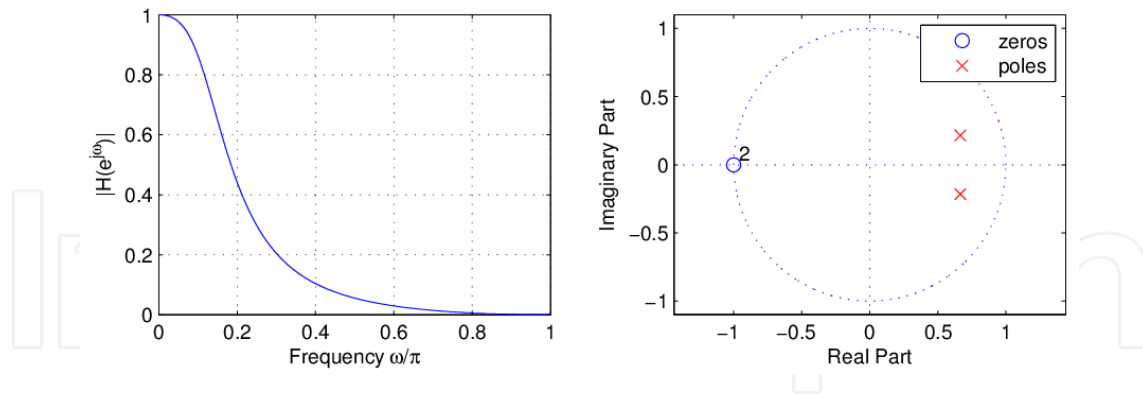

Figure 2. Frequency responses and zero-pole configurations of $H(z)$.

where $\lambda = 0.7 \exp(j0.1\pi)$, $\alpha = 1.6657 - j6.3055$, and $d = 1$. The frequency responses and zero-pole configurations of digital filter $H(z)$ are shown in Fig. 2. From the transfer function $H(z)$, parameters P , Q , and R are calculated as

$$P = 0.5068, Q = -0.2947, R = 0.25. \tag{63}$$

The coefficients s_n 's are computed as follows:

$$(s_{-2}, s_{-1}, s_0, s_1, s_2) = (0.3345, 0.8246, 0.8987, 0.8246, 0.7951). \tag{64}$$

We solve the following fourth-degree polynomial equation to derive the optimal solution β_{opt} :

$$\sum_{n=-2}^2 ns_n\beta^n = 0. \tag{65}$$

The fourth-degree polynomial equation above has the following four solutions:

$$\beta = 0.8568, -0.6960, -0.3396 \pm j0.7682. \tag{66}$$

We adopt $\beta_{\text{opt}} = 0.8568$, which is a positive real scalar, to derive the optimal positive definite symmetric matrix \mathbf{P}_{opt} . We can derive the minimum L_2 -sensitivity realization $(\mathbf{A}_{\text{opt}}, \mathbf{b}_{\text{opt}}, \mathbf{c}_{\text{opt}}, d_{\text{opt}})$ in closed form as follows:

$$\left[\begin{array}{c|c} \mathbf{A}_{\text{opt}} & \mathbf{b}_{\text{opt}} \\ \hline \mathbf{c}_{\text{opt}} & d_{\text{opt}} \end{array} \right] = \left[\begin{array}{cc|c} 0.7810 & 0.2451 & 0.4751 \\ -0.2451 & 0.5505 & 0.3061 \\ \hline 0.4751 & -0.3061 & 0.0396 \end{array} \right] \tag{67}$$

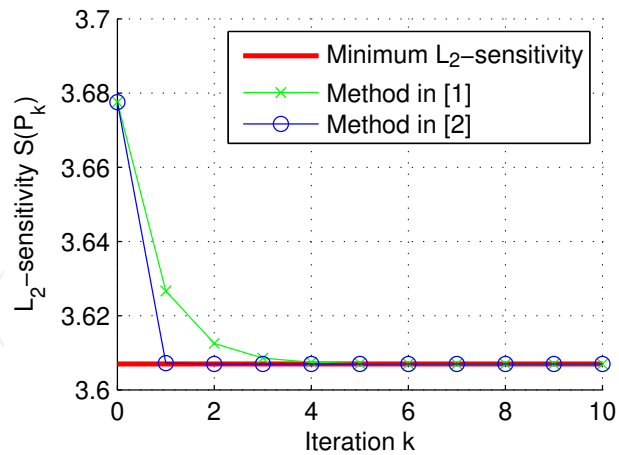

Figure 3. Minimum L_2 -sensitivity and convergence behaviors of L_2 -sensitivity in conventional methods [1] and [2].

of which L_2 -sensitivity S_{\min} is

$$S_{\min} = \sum_{n=-2}^2 s_n \beta_{\text{opt}}^n = 3.6070. \quad (68)$$

Figure 3 shows the comparison of our proposed method with the iterative methods reported in [1] and [2], where the initial realization is the balanced realization. Our proposed method achieves the minimum L_2 -sensitivity by only solving a fourth-degree polynomial equation without iterative calculations, while both of the methods in [1] and [2] require many iterative calculations to achieve the minimum L_2 -sensitivity. Furthermore, our proposed method can guarantee that the L_2 -sensitivity surely converges to the theoretical minimum when using conventional methods in [1] and [2].

4. Analytical solutions to the L_2 -sensitivity minimization problem for digital filters with all second-order modes equal

This section reveals that the L_2 -sensitivity minimization problem can be solved analytically if second-order modes are all equal. Furthermore, we clarify the general expression of the transfer functions of digital filters with all second-order modes equal [14].

4.1. Analytical synthesis of the minimum L_2 -sensitivity realizations

We have discovered that there exist some digital filters whose minimum L_2 -sensitivity realization is equal to the balanced realization. Such digital filters satisfy a sufficient condition summarized in the following theorem:

Theorem 3. *If all the second-order modes $\theta_i (i = 1, \dots, N)$ of a digital filter $H(z)$ are equal, then*

$$(\mathbf{A}_{\text{opt}}, \mathbf{b}_{\text{opt}}, \mathbf{c}_{\text{opt}}, d_{\text{opt}}) = (\mathbf{A}_b, \mathbf{b}_b, \mathbf{c}_b, d_b) \quad (69)$$

that is, the minimum L_2 -sensitivity realization is equal to the balanced realization. \square

Proof: The general Gramians of the balanced realization are given by Eqs. (49) and (50), respectively. If all the second-order modes $\theta_i (i = 1, \dots, N)$ satisfies

$$\theta_i = \theta \quad (i = 1, \dots, N) \quad (70)$$

the controllability and observability Gramians are expressed as

$$\mathbf{K}_0^{(b)} = \mathbf{W}_0^{(b)} = \text{diag}(\theta, \dots, \theta) = \theta \mathbf{I}. \quad (71)$$

Substituting Eq. (71) into Eqs. (49) and (50), the general Gramians are given by

$$\mathbf{K}_i^{(b)} = \mathbf{W}_i^{(b)} = \frac{1}{2} \theta (\mathbf{A}_b^i + (\mathbf{A}_b^T)^i). \quad (72)$$

We can express the general Gramians as $\mathbf{K}_i^{(b)} = \mathbf{W}_i^{(b)} = \Theta_i$, which is defined by

$$\Theta_i = \frac{1}{2} \theta (\mathbf{A}_b^i + (\mathbf{A}_b^T)^i) \quad (i = 0, 1, \dots). \quad (73)$$

Substituting $\mathbf{K}_i^{(b)} = \mathbf{W}_i^{(b)} = \Theta_i$ into Eq. (43) yields

$$\begin{aligned} \frac{\partial S(\mathbf{P})}{\partial \mathbf{P}} &= (1 + \text{tr}(\Theta_0 \mathbf{P}^{-1})) \Theta_0 + 2 \sum_{i=1}^{\infty} \text{tr}(\Theta_i \mathbf{P}^{-1}) \Theta_i \\ &\quad - \mathbf{P}^{-1} \left((1 + \text{tr}(\Theta_0 \mathbf{P})) \Theta_0 + 2 \sum_{i=1}^{\infty} \text{tr}(\Theta_i \mathbf{P}) \Theta_i \right) \mathbf{P}^{-1}. \end{aligned} \quad (74)$$

It is obvious that

$$\left. \frac{\partial S(\mathbf{P})}{\partial \mathbf{P}} \right|_{\mathbf{P}=\mathbf{I}} = \mathbf{0} \quad (75)$$

which means that the minimum L_2 -sensitivity realization can be synthesized without any coordinate transformation to the balanced realization, that is, the initial realization. Therefore, it is proved that the minimum L_2 -sensitivity is equal to the balanced realization. \square

4.2. Class of digital filters with all second-order modes equal

In the previous subsection, we revealed that the L_2 -sensitivity minimization problem can be solved analytically if second-order modes are all equal. We next clarify the class of digital filters with all second-order modes equal. We have newly derived a general expression of the transfer function of N th-order digital filters with all second-order modes equal.

4.2.1. General expression

In Ref. [14], we have newly derived a general expression of the transfer function of N th-order digital filters with all second-order modes equal.

Corollary 1. *Let the second-order modes of an N th-order digital filter $H(z)$ be $\theta_i (i = 1, \dots, N)$. The second-order modes of the transfer function $\theta H(z)$ are given by $|\theta|\theta_i (i = 1, \dots, N)$, where θ is a nonzero real scalar.*

Theorem 4. *The transfer function of an N th-order digital filter $H(z)$ with all second-order modes equal such as*

$$\theta_1 = \theta_2 = \dots = \theta_{N-1} = \theta_N \quad (76)$$

can be expressed as the following form:

$$H(z) = \theta H_{AP}(z) + \rho \quad (77)$$

where θ is a nonzero real scalar, ρ is a real scalar, and $H_{AP}(z)$ is an N th-order all-pass digital filter. The second-order modes of the digital filter $H(z)$ are given by

$$\theta_i = |\theta| \quad (i = 1, \dots, N). \quad (78)$$

□

4.2.2. Frequency transformation

Furthermore, it is remarkable that the transfer function $H(z)$ in Eq. (77) is generally obtained by the frequency transformation on a first-order FIR prototype filter using an N th-order all-pass digital filter.

Remark 1. *An N th-order digital filter $H(z)$ in Eq. (77) is obtained by the frequency transformation such as*

$$H(z) = H_P(z) \Big|_{z^{-1} \leftarrow H_{AP}(z)} \quad (79)$$

where $H_P(z) = \theta z^{-1} + \rho$ is a first-order prototype FIR digital filter and $H_{AP}(z)$ is an N th-order all-pass digital filter. □

The variable substitution in Eq. (79) represents the frequency transformation, where $H_P(z)$ is the prototype digital filter. Block diagrams of the prototype digital filter $H_P(z)$ and transformed digital filter $H(z)$ are shown in Fig. 4. These figures show that a block diagram of the transformed digital filter $H(z)$ can be obtained by simple substitution of the all-pass digital filter $H_{AP}(z)$ into the unit delay z^{-1} . Theorem 4 and Remark 1 give us the class of digital filters with all second-order modes equal.

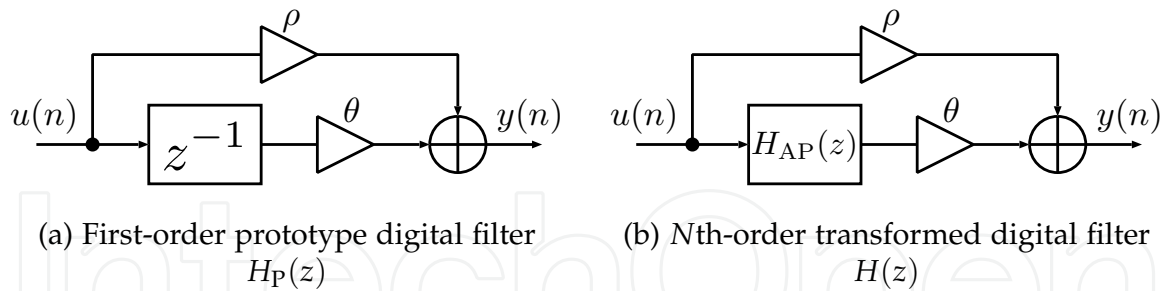

Figure 4. Block diagrams of prototype digital filter $H_P(z)$ and transformed digital filter $H(z)$.

4.3. Examples of digital filters with all second-order modes equal

There are many types of digital filters with all second-order modes equal. We can design various digital filters by setting variables θ , ρ , and $H_{AP}(z)$.

4.3.1. The unit delay

The unit delay is the simplest example for digital filter with all second-order modes equal. It is obvious that letting $\theta = 1$, $\rho = 0$, and $H_{AP}(z) = z^{-1}$ in Eq. (77) yields the unit delay z^{-1} .

4.3.2. First-order digital filters

Any first-order digital filter can be expressed in the form of Eq. (77). Consider a first-order IIR digital filter given by

$$H_{IIR}(z) = \frac{b_0 + b_1 z^{-1}}{1 + a_1 z^{-1}} \quad (80)$$

where b_0 and b_1 are numerator coefficients, a_1 is a denominator coefficient. One can easily show that Eq. (80) can be rewritten as the form of Eq. (77) where

$$\theta = \frac{b_1 - a_1 b_0}{1 - a_1^2}, \quad \rho = \frac{b_0 - a_1 b_1}{1 - a_1^2}, \quad H_{AP}(z) = \frac{a_1 + z^{-1}}{1 + a_1 z^{-1}}. \quad (81)$$

4.3.3. All-pass digital filters

It is obvious that all-pass digital filters are included in the class of digital filters expressed as Eq. (77). The transfer function $H(z)$ in Eq. (77) is an all-pass digital filter when we let $\theta = 1$ and $\rho = 0$.

4.3.4. Multi-notch comb digital filters

The transfer function of an N th-order multi-notch comb digital filter is given by

$$H_{MN}(z) = \frac{1 + \alpha}{2} \frac{1 - z^{-N}}{1 - \alpha z^{-N}}. \quad (82)$$

This filter has N notches at the frequency $2\pi k/N$ [rad] for $k = 1, \dots, N$. One can easily show that Eq. (82) can be rewritten as the form of Eq. (77) where

$$\theta = \frac{1}{2}, \rho = \frac{1}{2}, H_{AP}(z) = \frac{\alpha - z^{-1}}{1 - \alpha z^{-1}}. \quad (83)$$

4.4. Numerical examples

This subsection gives numerical examples of synthesis of the minimum L_2 -sensitivity realizations for various types of digital filters with all second-order modes equal.

4.4.1. First-order FIR digital filters

Consider a first-order FIR digital filter $H_{FIR}(z)$ given by

$$H_{FIR}(z) = 0.5 + 0.5z^{-1} \quad (84)$$

of which frequency magnitude and phase responses are shown in Fig. 5 (a). The second-order mode of the digital filter $H_{FIR}(z)$ is $\theta = 0.5$. The balanced realization (A_b, b_b, c_b, d_b) , which is equal to the minimum L_2 -sensitivity realization, of $H_{FIR}(z)$ is derived as

$$\left[\begin{array}{c|c} A_b & b_b \\ \hline c_b & d_b \end{array} \right] = \left[\begin{array}{c|c} 0 & 0.7071 \\ \hline 0.7071 & 0.5 \end{array} \right] \quad (85)$$

and controllability Gramian $K_0^{(b)}$ and observability Gramians $W_0^{(b)}$ are calculated as

$$K_0^{(b)} = W_0^{(b)} = 0.5. \quad (86)$$

4.4.2. First-order IIR digital filters

Consider a first-order IIR digital filter $H_{IIR}(z)$ given by

$$H_{IIR}(z) = \frac{0.25 + 0.25z^{-1}}{1 - 0.5z^{-1}} \quad (87)$$

of which frequency magnitude and phase responses are shown in Fig. 5 (b). The second-order mode of the digital filter $H_{IIR}(z)$ is $\theta = 0.5$. The balanced realization

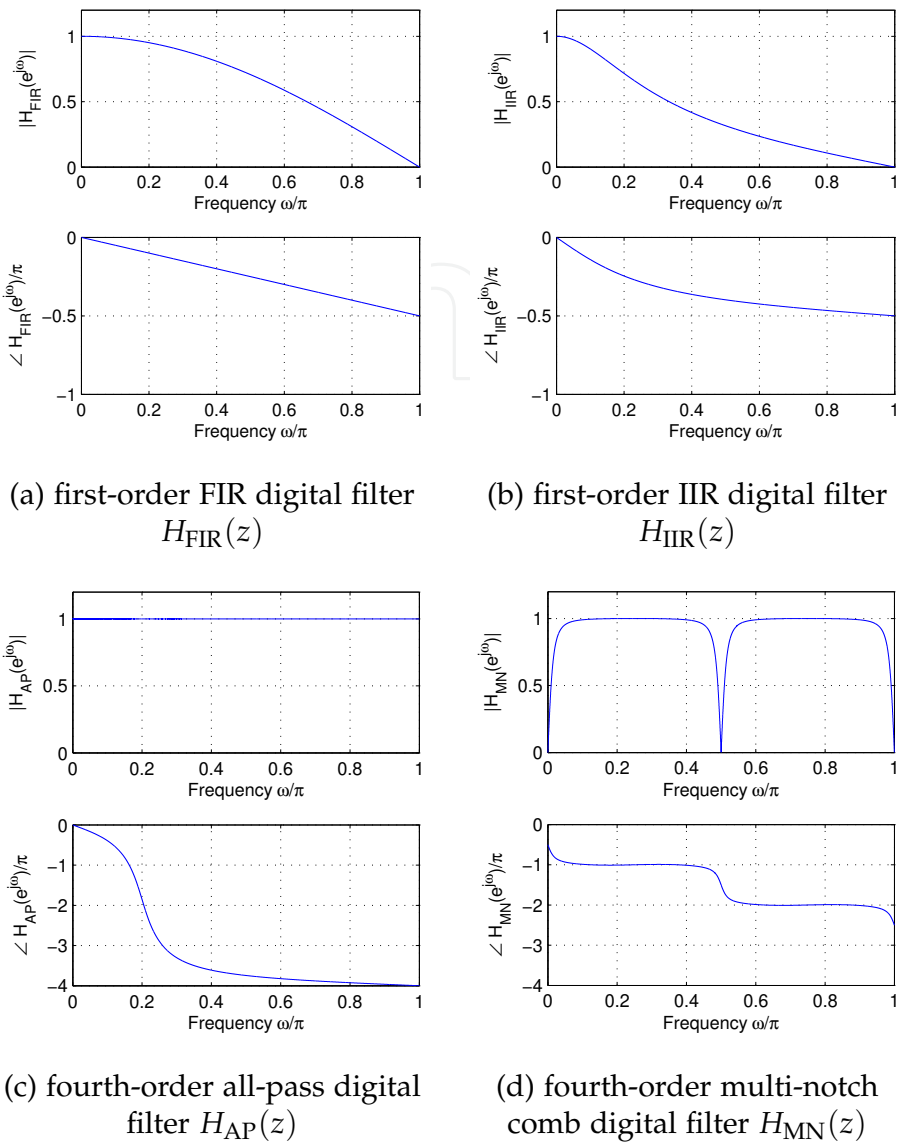

Figure 5. Frequency magnitude and phase responses of digital filters with all second-order modes equal.

(A_b, b_b, c_b, d_b) , which is equal to the minimum L_2 -sensitivity realization, of $H_{\text{IIR}}(z)$ is derived as

$$\begin{bmatrix} A_b & b_b \\ c_b & d_b \end{bmatrix} = \begin{bmatrix} 0.5 & 0.6124 \\ 0.6124 & 0.25 \end{bmatrix} \quad (88)$$

and controllability Gramian $K_0^{(b)}$ and observability Gramians $W_0^{(b)}$ are calculated as

$$K_0^{(b)} = W_0^{(b)} = 0.5. \quad (89)$$

4.4.3. All-pass digital filters

Consider a fourth-order all-pass digital filter $H_{AP}(z)$ given by

$$H_{AP}(z) = \frac{0.5184 - 1.9805z^{-1} + 3.3350z^{-2} - 2.7507z^{-3} + z^{-4}}{1 - 2.7507z^{-1} + 3.3350z^{-2} - 1.9805z^{-3} + 0.5184z^{-4}} \quad (90)$$

of which poles $\lambda_p (p = 1, 2, 3, 4)$ are given by

$$\begin{cases} \lambda_1 = 0.9 \exp(j0.2\pi), \lambda_2 = 0.9 \exp(-j0.2\pi), \\ \lambda_3 = 0.8 \exp(j0.2\pi), \lambda_4 = 0.8 \exp(-j0.2\pi) \end{cases} \quad (91)$$

and of which frequency magnitude and phase responses are shown in Fig. 5 (c). The second-order modes $\theta_i (i = 1, 2, 3, 4)$ of the all-pass digital filter $H_{AP}(z)$ are given by

$$(\theta_1, \theta_2, \theta_3, \theta_4) = (1, 1, 1, 1). \quad (92)$$

The balanced realization (A_b, b_b, c_b, d_b) , which is equal to the minimum L_2 -sensitivity realization, of $H_{AP}(z)$ is derived as

$$\left[\begin{array}{c|c} A_b & b_b \\ \hline c_b & d_b \end{array} \right] = \left[\begin{array}{cccc|c} 0.8144 & -0.1106 & 0.2499 & -0.5039 & -0.0903 \\ 0.1599 & 0.4698 & -0.7114 & -0.1105 & -0.4853 \\ -0.1616 & 0.2997 & 0.6211 & 0.1062 & -0.6978 \\ 0.5318 & 0.0448 & 0.0006 & 0.8453 & 0.0252 \\ \hline 0.0481 & 0.8217 & 0.2137 & -0.0894 & 0.5184 \end{array} \right] \quad (93)$$

and controllability Gramian $K_0^{(b)}$ and observability Gramians $W_0^{(b)}$ are calculated as

$$K_0^{(b)} = W_0^{(b)} = \text{diag}(1, 1, 1, 1). \quad (94)$$

4.4.4. Multi-notch comb digital filters

Consider a fourth-order multi-notch comb digital filter $H_{MN}(z)$ given by

$$H_{MN}(z) = \frac{0.9073 - 0.9073z^{-4}}{1 - 0.8145z^{-4}} \quad (95)$$

of which poles $\lambda_p (p = 1, 2, 3, 4)$ are given by

$$\begin{cases} \lambda_1 = 0.95, \lambda_2 = -0.95, \\ \lambda_3 = j0.95, \lambda_4 = -j0.95 \end{cases} \quad (96)$$

and of which frequency magnitude and phase responses are shown in Fig. 5 (d). The second-order modes θ_i ($i = 1, 2, 3, 4$) of the multi-notch comb digital filter $H_{MN}(z)$ are given by

$$(\theta_1, \theta_2, \theta_3, \theta_4) = (0.5, 0.5, 0.5, 0.5). \quad (97)$$

The balanced realization (A_b, b_b, c_b, d_b) , which is equal to the minimum L_2 -sensitivity realization, of $H_{MN}(z)$ is derived as

$$\left[\begin{array}{c|c} A_b & b_b \\ \hline c_b & d_b \end{array} \right] = \left[\begin{array}{ccc|c} 0 & 0 & 0 & 0.8145 \\ 1 & 0 & 0 & 0 \\ 0 & 1 & 0 & 0 \\ 0 & 0 & 1 & 0 \\ \hline 0 & 0 & 0 & -0.4102 \end{array} \middle| \begin{array}{c} 0.4102 \\ 0 \\ 0 \\ 0 \\ 0.9073 \end{array} \right] \quad (98)$$

and controllability Gramian $K_0^{(b)}$ and observability Gramians $W_0^{(b)}$ are calculated as

$$K_0^{(b)} = W_0^{(b)} = \text{diag}(0.5, 0.5, 0.5, 0.5). \quad (99)$$

5. Absence of limit cycles in the minimum L_2 -sensitivity realizations

This section proves the absence of limit cycles of the minimum L_2 -sensitivity realization from the viewpoint of the controllability and observability Gramians. The minimum L_2 -sensitivity realizations have freedom for orthogonal transformations. In other words, minimum L_2 -sensitivity realizations are not unique. We select the minimum L_2 -sensitivity realization without limit cycles among these minimum L_2 -sensitivity realizations. The controllability and observability Gramians of the selected minimum L_2 -sensitivity realization satisfy a sufficient condition for the absence of limit cycles [11].

5.1. Theoretical proof of the absence of limit cycles

For high-order digital filters, we synthesize the minimum L_2 -sensitivity realization by the successive approximation methods in [1] or [2], for examples. For second-order digital filters, we can synthesize the minimum L_2 -sensitivity realization by the closed form solutions proposed in Section 3. For both cases, we can construct the minimum L_2 -sensitivity realization *without limit cycles*.

We begin by reviewing the procedure to synthesize the minimum L_2 -sensitivity. We solve the L_2 -sensitivity minimization problem in (32) adopting the balanced realization (A_b, b_b, c_b, d_b) as an initial realization. We obtain the optimal positive definite symmetric matrix P_{opt} . In case of high-order digital filters, we can derive the optimal positive definite symmetric matrix P_{opt} by successive approximation method in [1] or [2], for example. In case of second-order digital filters, we can derive the optimal positive definite symmetric matrix P_{opt} analytically as proposed in Section 3.

We can give the diagonalization of the matrix P_{opt} as follows:

$$P_{\text{opt}} = R^T B_{\text{opt}} R. \quad (100)$$

Since the matrix P_{opt} is positive definite symmetric, it can be diagonalized by an orthogonal matrix R , and B_{opt} is a positive definite diagonal matrix. The optimal coordinate transformation matrix T_{opt} is given by

$$\begin{aligned} T_{\text{opt}} &= P_{\text{opt}}^{\frac{1}{2}} U \\ &= R^T B_{\text{opt}}^{\frac{1}{2}} R U. \end{aligned} \quad (101)$$

In the above expression, U is an arbitrary orthogonal matrix. It means that the minimum L_2 -sensitivity realizations exist infinitely for a given digital filter $H(z)$. The minimum L_2 -sensitivity realizations have freedom for orthogonal transformations. We show that the minimum L_2 -sensitivity realization does not generate limit cycles if we specify the orthogonal matrix as $U = R^T$, which yields

$$\tilde{T}_{\text{opt}} = R^T B_{\text{opt}}^{\frac{1}{2}}. \quad (102)$$

Theorem 5. *The minimum L_2 -sensitivity realization $(\tilde{A}_{\text{opt}}, \tilde{b}_{\text{opt}}, \tilde{c}_{\text{opt}}, \tilde{d}_{\text{opt}})$, obtained by the coordinate transformation by \tilde{T}_{opt} such as*

$$(\tilde{A}_{\text{opt}}, \tilde{b}_{\text{opt}}, \tilde{c}_{\text{opt}}, \tilde{d}_{\text{opt}}) = (\tilde{T}_{\text{opt}}^{-1} A_b \tilde{T}_{\text{opt}}, \tilde{T}_{\text{opt}}^{-1} b_b, c_b \tilde{T}_{\text{opt}}, d_b) \quad (103)$$

does not generate limit cycles. □

Proof: Under the coordinate transformation by \tilde{T}_{opt} in Eq. (102), the controllability Gramian $\tilde{K}_0^{(\text{opt})}$ and the observability Gramian $\tilde{W}_0^{(\text{opt})}$ of the minimum L_2 -sensitivity realization $(\tilde{A}_{\text{opt}}, \tilde{b}_{\text{opt}}, \tilde{c}_{\text{opt}}, \tilde{d}_{\text{opt}})$ are expressed as

$$\begin{aligned} \tilde{K}_0^{(\text{opt})} &= \tilde{T}_{\text{opt}}^{-1} K_0^{(b)} \tilde{T}_{\text{opt}}^{-T} \\ &= B_{\text{opt}}^{-\frac{1}{2}} R \Theta R^T B_{\text{opt}}^{-\frac{1}{2}} \end{aligned} \quad (104)$$

$$\begin{aligned} \tilde{W}_0^{(\text{opt})} &= \tilde{T}_{\text{opt}}^T W_0^{(b)} \tilde{T}_{\text{opt}} \\ &= B_{\text{opt}}^{\frac{1}{2}} R \Theta R^T B_{\text{opt}}^{\frac{1}{2}} \end{aligned} \quad (105)$$

where $\Theta = \text{diag}(\theta_1, \dots, \theta_N)$. From Eqs. (104) and (105), we can derive the relation between the controllability and observability Gramians as follows:

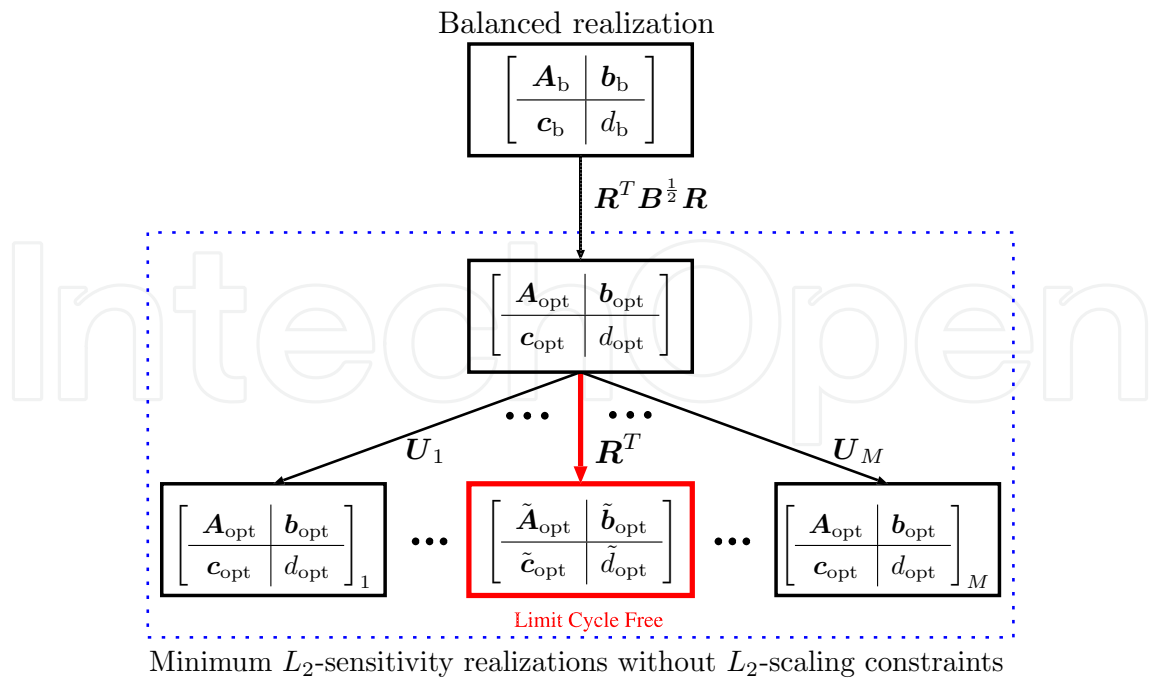

Figure 6. Synthesis of the minimum L_2 -sensitivity realization which does not generate limit cycles.

$$\tilde{W}_0^{(opt)} = B_{opt} \tilde{K}_0^{(opt)} B_{opt}. \tag{106}$$

Eq. (106) is equivalent to a sufficient condition for the absence of limit cycles proposed in Ref. [6]. Therefore, the minimum L_2 -sensitivity realization $(\tilde{A}_{opt}, \tilde{b}_{opt}, \tilde{c}_{opt}, \tilde{d}_{opt})$ does not generate limit cycles. \square

Theorem 5 shows that we can synthesize the minimum L_2 -sensitivity realization without limit cycles by choosing appropriate orthogonal matrix U . Fig. 6 shows the synthesis procedure of the minimum L_2 -sensitivity realization which does not generate limit cycles. The coefficient matrices of the minimum L_2 -sensitivity realization without limit cycles $(\tilde{A}_{opt}, \tilde{b}_{opt}, \tilde{c}_{opt}, \tilde{d}_{opt})$ are given by

$$\begin{bmatrix} \tilde{A}_{opt} & \tilde{b}_{opt} \\ \tilde{c}_{opt} & \tilde{d}_{opt} \end{bmatrix} = \begin{bmatrix} B_{opt}^{-\frac{1}{2}} R A_b R^T B_{opt}^{\frac{1}{2}} & B_{opt}^{-\frac{1}{2}} R b_b \\ c_b R^T B_{opt}^{\frac{1}{2}} & d \end{bmatrix}. \tag{107}$$

5.2. Numerical examples

We present numerical examples to demonstrate the validity of our proposed method. We synthesize the minimum L_2 -sensitivity realizations of second-order and fourth-order digital filters which do not generate limit cycles.

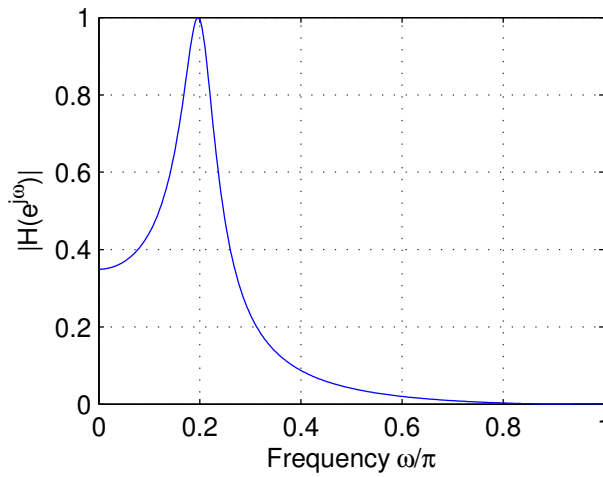

Figure 7. Frequency Response of digital filter $H(z)$ in Eq. (108).

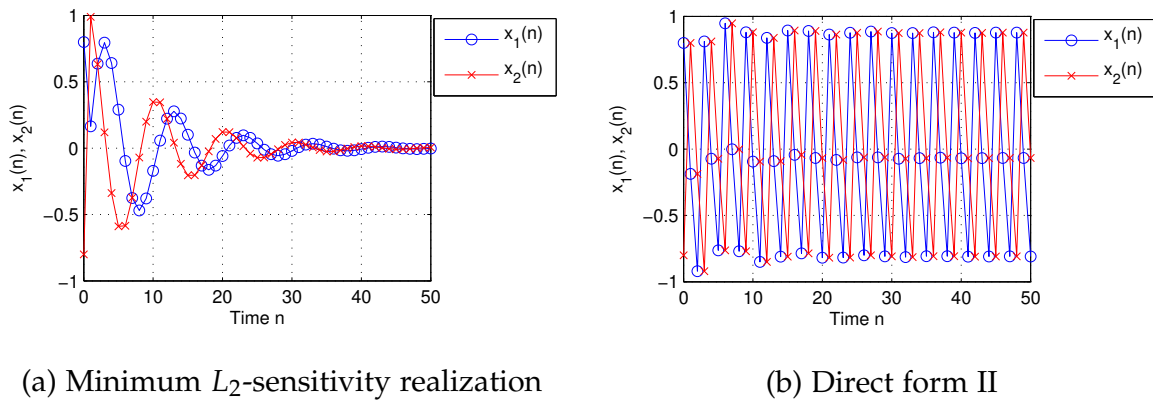

Figure 8. Zero-input responses of $H(z)$ in Eq. (108).

5.2.1. Second-order digital filters

Consider a second-order narrow-band band-pass digital filter $H(z)$ given by

$$H(z) = \frac{0.0316 + 0.0602z^{-1} + 0.0316z^{-2}}{1 - 1.4562z^{-1} + 0.81z^{-2}}. \quad (108)$$

The poles of the transfer function $H(z)$ in Eq. (108) are $0.9 \exp(\pm j0.2\pi)$, which are very close to the unit circle. The frequency response of the digital filter $H(z)$ in Eq. (108) is shown in Fig. 7. The coefficient matrices of the minimum L_2 -sensitivity realization which is free of limit cycle is derived by Eq. (107) as follows:

$$\left[\begin{array}{cc|c} \tilde{\mathbf{A}}_{\text{opt}} & \tilde{\mathbf{b}}_{\text{opt}} & \\ \hline \tilde{\mathbf{c}}_{\text{opt}} & \tilde{\mathbf{d}}_{\text{opt}} & \end{array} \right] = \left[\begin{array}{cc|c} 0.7281 & 0.5229 & 0.4146 \\ -0.5351 & 0.7281 & -0.1282 \\ \hline 0.1282 & -0.4146 & 0.0316 \end{array} \right]. \quad (109)$$

The controllability Gramian $\mathbf{K}_0^{(\text{opt})}$ and the observability Gramian $\mathbf{W}_0^{(\text{opt})}$ are given as follows:

$$\tilde{\mathbf{K}}_0^{(\text{opt})} = \begin{bmatrix} 0.5100 & -0.0870 \\ -0.0870 & 0.4901 \end{bmatrix} \quad (110)$$

$$\tilde{\mathbf{W}}_0^{(\text{opt})} = \begin{bmatrix} 0.4901 & -0.0870 \\ -0.0870 & 0.5100 \end{bmatrix}. \quad (111)$$

We have to note that the controllability Gramian $\tilde{\mathbf{K}}_0^{(\text{opt})}$ and the observability Gramian $\tilde{\mathbf{W}}_0^{(\text{opt})}$ satisfy the sufficient condition of the absence of limit cycles given in Eq. (106) with

$$\mathbf{B}_{\text{opt}} = \text{diag}(0.9803, 1.0201). \quad (112)$$

Therefore, $(\tilde{\mathbf{A}}_{\text{opt}}, \tilde{\mathbf{b}}_{\text{opt}}, \tilde{\mathbf{c}}_{\text{opt}}, \tilde{\mathbf{d}}_{\text{opt}})$ is the minimum L_2 -sensitivity realization without limit cycles.

We demonstrate the absence of limit cycles in the minimum L_2 -sensitivity realization by observing its zero-input response. We calculate the zero-input responses of the minimum L_2 -sensitivity realization and the direct form II, setting the initial state as $\mathbf{x}(0) = [0.8 \ -0.8]^T$. We let the dynamic range of signals to be $[-1, 1)$ and adopt two's complement as the overflow characteristic. The zero-input responses are shown in Fig. 8(a) and 8(b). We assume that each filter coefficient and signal have 16[bits] fixed-point representation, of which lower 14[bits] are fractional bits. In this numerical example, the overflow of the state variables occurs in both cases. It is desirable that the effect of the overflow is decreasing since the digital filter $H(z)$ in Eq. (108) is stable. For the minimum L_2 -sensitivity realization synthesized by our proposed method, the state variables $x_1(n)$ and $x_2(n)$ converge to zero after the overflow, as shown in Fig. 8(a). Therefore, there are no limit cycles. On the other hand, for the direct form II, a large-amplitude autonomous oscillation is observed as shown in Fig. 8(b). Therefore, the direct form II generates the limit cycles.

5.2.2. High-order digital filters

We can demonstrate the validity of the proposed method for also high-order digital filters. Consider a fourth-order band-pass digital filter $H(z)$ given by

$$H(z) = \frac{0.0178 - 0.0252z^{-1} + 0.0173z^{-2} - 0.0252z^{-3} + 0.0178z^{-4}}{1 - 2.6977z^{-1} + 3.5410z^{-2} - 2.3340z^{-3} + 0.7497z^{-4}} \quad (113)$$

The frequency response of the digital filter $H(z)$ in Eq. (113) is shown in Fig. 9. We obtain the limit cycle free minimum L_2 -sensitivity realization $(\tilde{\mathbf{A}}_{\text{opt}}, \tilde{\mathbf{b}}_{\text{opt}}, \tilde{\mathbf{c}}_{\text{opt}}, \tilde{\mathbf{d}}_{\text{opt}})$ by successive approximation method:

$$\left[\begin{array}{c|c} \tilde{A}_{\text{opt}} & \tilde{b}_{\text{opt}} \\ \hline \tilde{c}_{\text{opt}} & \tilde{d}_{\text{opt}} \end{array} \right] = \left[\begin{array}{cccc|c} 0.6028 & 0.6394 & 0.1512 & 0.0655 & 0.0344 \\ -0.6360 & 0.7461 & -0.0655 & -0.0297 & -0.0153 \\ -0.0806 & -0.0283 & 0.6028 & 0.6360 & 0.3950 \\ 0.0283 & 0.0118 & -0.6394 & 0.7461 & -0.1423 \\ \hline 0.3950 & 0.1423 & 0.0344 & 0.0153 & 0.0178 \end{array} \right]. \quad (114)$$

The controllability Gramian $\tilde{K}_0^{(\text{opt})}$ and the observability Gramian $\tilde{W}_0^{(\text{opt})}$ are given as follows:

$$\tilde{K}_0^{(\text{opt})} = \begin{bmatrix} 0.3531 & -0.0004 & 0.2470 & 0.0155 \\ -0.0004 & 0.3563 & -0.0157 & 0.2470 \\ 0.2470 & -0.0157 & 0.5309 & 0.0006 \\ 0.0155 & 0.2470 & 0.0006 & 0.5264 \end{bmatrix} \quad (115)$$

$$\tilde{W}_0^{(\text{opt})} = \begin{bmatrix} 0.5309 & -0.0006 & 0.2470 & 0.0157 \\ -0.0006 & 0.5264 & -0.0155 & 0.2470 \\ 0.2470 & -0.0155 & 0.3531 & 0.0004 \\ 0.0157 & 0.2470 & 0.0004 & 0.3563 \end{bmatrix}. \quad (116)$$

We have to note that the controllability Gramian $\tilde{K}_0^{(\text{opt})}$ and the observability Gramian $\tilde{W}_0^{(\text{opt})}$ satisfy the sufficient condition of the absence of limit cycles given in Eq. (106) with

$$B_{\text{opt}} = \text{diag}(1.2261, 1.2155, 0.8156, 0.8227). \quad (117)$$

Therefore, $(\tilde{A}_{\text{opt}}, \tilde{b}_{\text{opt}}, \tilde{c}_{\text{opt}}, \tilde{d}_{\text{opt}})$ is the minimum L_2 -sensitivity realization without limit cycles.

We demonstrate the absence of limit cycles in the minimum L_2 -sensitivity realization by observing its zero-input response. We calculate the zero-input responses of the minimum L_2 -sensitivity realization and the direct form II, setting the initial state as $x(0) = [0.9 \ 0.9 \ 0.9 \ 0.9]^T$. We let the dynamic range of signals to be $[-1, 1)$ and adopt two's complement as the overflow characteristic. The zero-input responses are shown in Fig. 10(a) and 10(b). We assume that each filter coefficient and signal have 16[bits] fixed-point representation, of which lower 13[bits] are fractional bits. In this numerical example, the overflow of the state variables occurs in both cases. Also in this case, we can confirm that the minimum L_2 -sensitivity realization does not generate limit cycles. On the other hand, a large-amplitude autonomous oscillation is observed in the zero-input response of the direct form II.

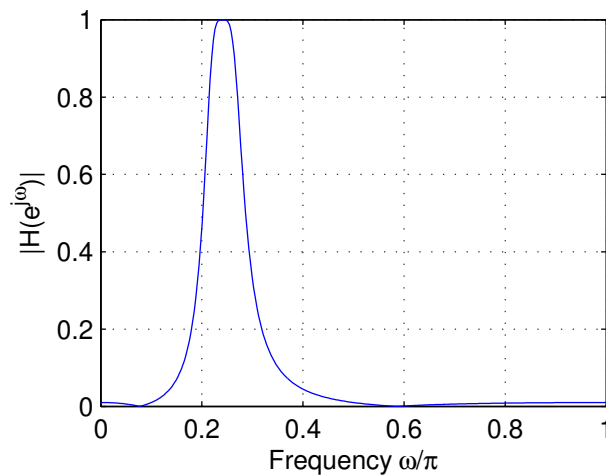
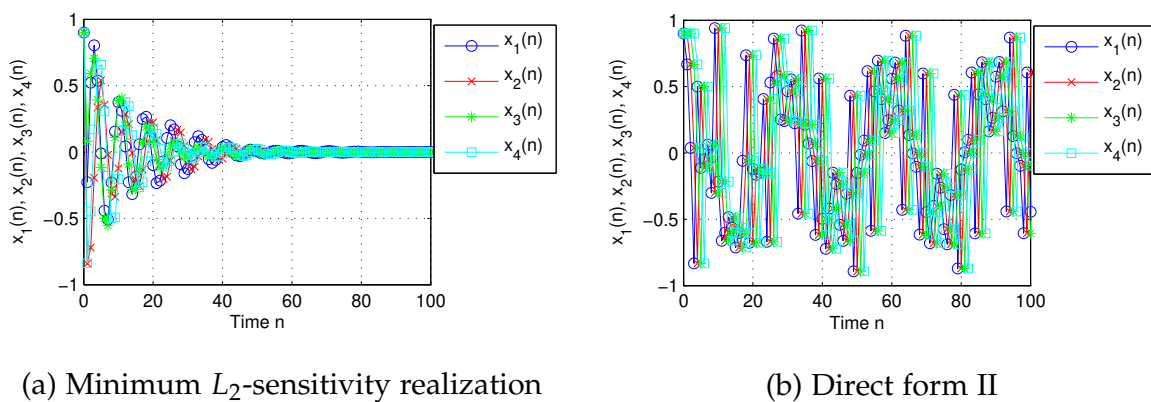

Figure 9. Frequency Response of digital filter $H(z)$ in Eq. (113).



(a) Minimum L_2 -sensitivity realization

(b) Direct form II

Figure 10. Zero-input responses of digital filter $H(z)$ in Eq. (113).

6. Conclusions

This chapter presents analytical approach for synthesis of the minimum L_2 -sensitivity realizations for state-space digital filters. The contributions of this chapter are summarized as follows.

Section 3 presents closed form solutions to the L_2 -sensitivity minimization problem for second-order state-space digital filters. We have shown that the L_2 -sensitivity is expressed by a linear combination of exponential functions, and we can synthesize the minimum L_2 -sensitivity realization by only solving a fourth degree polynomial equation, which can be solved analytically.

Section 4 reveals that the L_2 -sensitivity minimization problem can be solved analytically for arbitrary filter order if second-order modes are all equal. We derive a general expression of the transfer function of digital filters with all second-order modes equal. We show that the general expression is obtained by a frequency transformation on a first-order prototype FIR digital filter.

Section 5 proves the absence of limit cycles of the minimum L_2 -sensitivity realization from the view point of relationship between the controllability and observability Gramians. The minimum L_2 -sensitivity realizations were originally known to be low-coefficient sensitivity filter structures. We have succeeded in discovering the novel property of the minimum L_2 -sensitivity realizations.

Author details

Shunsuke Yamaki*,
Masahide Abe and Masayuki Kawamata

* Address all correspondence to: yamaki@mk.ecei.tohoku.ac.jp

Department of Electronic Engineering, Graduate School of Engineering, Tohoku University, Sendai, Japan

References

- [1] W.-Y. Yan and J. B. Moore. On L_2 -sensitivity minimization of linear state-space systems. *IEEE Trans. Circuits Syst. I Fundamental theory and applications*, 39(8):641–648, August 1992.
- [2] T. Hinamoto, S. Yokoyama, T. Inoue, W. Zeng, and W.-S. Lu. Analysis and minimization of L_2 -sensitivity for linear systems and two-dimensional state-space filters using general controllability and observability gramians. *IEEE Trans. Circuits Syst., CAS-49(9)*:1279–1289, September 2002.
- [3] Clifford T. Mullis and Richard A. Roberts. Synthesis of minimum roundoff noise fixed point digital filters. *IEEE Trans. Circuits Syst., CAS-23(9)*:551–562, September 1976.
- [4] Clifford T. Mullis and Richard A. Roberts. Roundoff noise in digital filters: Frequency transformations and invariants. *IEEE Trans. Acoust., Speech, Signal Process., ASSP-24(6)*:538–550, December 1976.
- [5] Sheng Y. Hwang. Minimum uncorrelated unit noise in state-space digital filtering. *IEEE Trans. Acoust., Speech, Signal Process., ASSP-25(4)*:273–281, August 1977.
- [6] M. Kawamata and T. Higuchi. On the absence of limit cycles in a class of state-space digital filters which contains minimum noise realizations. *IEEE Trans. Acoust., Speech, Signal Process., ASSP-32(4)*:928–930, August 1984.
- [7] M. Kawamata and T. Higuchi. A unified approach to the optimal synthesis of fixed-point state-space digital filters. *IEEE Trans. Acoust., Speech, Signal Process., ASSP-33(4)*:911–920, August 1985.
- [8] V. Tavsanoğlu and L. Thiele. Optimal design of state-space digital filters by simultaneous minimization of sensitivity and roundoff noise. *IEEE Trans. Circuits Syst., CAS-31(10)*:884–888, October 1984.

- [9] M. Gevers and G. Li. *Parametrizations in Control, Estimation and Filtering Problems*, chapter 5. Springer-Verlag, 1993.
- [10] Robert S. H. Istepanian and James F. Whidborne. *Digital Controller Implementation and Fragility*. Springer-Verlag, 2001.
- [11] S. Yamaki, M. Abe, and M. Kawamata. On the absence of limit cycles in state-space digital filters with minimum L_2 -sensitivity. *IEEE Trans. Circuits Syst. II*, 55(1):46–50, January 2008.
- [12] S. Yamaki, M. Abe, and M. Kawamata. A closed form solution to L_2 -sensitivity minimization of second-order state-space digital filters. *IEICE Trans. Fundam. Electron., Commun., Comput. Sci.*, E91-A(5):1268–1273, May 2008.
- [13] S. Yamaki, M. Abe, and M. Kawamata. Closed form solutions to L_2 -sensitivity minimization of second-order state-space digital filters with real poles. *IEICE Trans. Fundam. Electron., Commun., Comput. Sci.*, E93-A(5):966–971, May 2010.
- [14] S. Yamaki, M. Abe, and M. Kawamata. Derivation of the class of digital filters with all second-order modes equal. *IEEE Trans. Signal Process.*, 59(11):5236–5242, November 2011.
- [15] H. Matsukawa and M. Kawamata. Design of variable digital filters based on state-space realizations. *IEICE Trans. Fundam. Electron., Commun., Comput. Sci.*, E84-A(8):1822–1830, August 2001.
- [16] G. Cardano and translated by T. R. Witmer with a foreword by O. Ore. *The Great Art or the Rules of Algebra*. The M. I. T. Press, 1968.