

We are IntechOpen, the world's leading publisher of Open Access books Built by scientists, for scientists

4,800

Open access books available

122,000

International authors and editors

135M

Downloads

Our authors are among the

154

Countries delivered to

TOP 1%

most cited scientists

12.2%

Contributors from top 500 universities



WEB OF SCIENCE™

Selection of our books indexed in the Book Citation Index
in Web of Science™ Core Collection (BKCI)

Interested in publishing with us?
Contact book.department@intechopen.com

Numbers displayed above are based on latest data collected.

For more information visit www.intechopen.com



Sensor Applications of Polyimides

Aziz Paşahan

Additional information is available at the end of the chapter

<http://dx.doi.org/10.5772/53456>

1. Introduction

A sensor is a converter that measures a physical quantity and converts it into a signal which can be read by an observer or by an instrument. Nowadays common sensors convert measurement of physical phenomena into an electrical signal.

Polyimides have inherently high mechanical properties, good chemical resistance, a low dielectric constant and high thermal stability [1]. In recent years, polyimide-based sensor materials have received much attention due to their simple preparation method, chemical inertness, mechanical and thermal stability, and high biocompatibility[2–4]. Thus they have a wide range of diverse and potential applications in several major technologies. Among the polymers, polyimides (PI) possess reliable high-temperature stability, excellent chemical resistance, high hydrolytic stability, adhesive properties, and good mechanical strength [7–9]. Polysulfones and phosphine oxidecontaining polyimides have excellent adhesive properties without sacrificing thermal stability [10–12].

Polyimides have found applications as enzyme immobilization membrane, due to their good chemical stability and low reactivity[13–16]. The main criteria for selecting a specific polyimide as a membrane material to be used in a given commercial application are diverse and complex but, besides mechanical and thermal stability, other factors are important, such as manufacturing reproducibility, tolerance to contaminants and other economical issues, without omission of permeation rate and selectivity, which are the most important characteristics[17–19]. Flexible electronics has developed greatly in recent years. Many flexible materials have been used in flexible lower cost sensors, larger area manufacturing, and packages that are significantly thinner, lighter, and more compact. It is worth noting that the polyimide (PI) material is beginning to be applied in flexible fields due to its good mechanical strength, higher glass transition temperature, electrochemical stability, and flexibility in polymer materials[20].

Wessa et al. described two methods for the direct coupling of proteins to polyimide. With the cyano-transfer technique, anti-glucose oxidase was coupled to the polymer surface for the detection of glucose oxidase. In a second approach, glucose oxidase was derivatized with photoreactive groups via 3-trifluoromethyl 3-(*m*-isothiocyanophenyl)-diazirine (TRIMID) and immobilized on the polyimide layer via photochemistry. The subsequent binding of the corresponding antibody was observed. Sakong et al. suggest a SAW biosensor that is supplied with a fluidic system consisting of a microfluidic polyimide tubing system. The system is designed for the detection of DNA[21]. Ekinci and coworkers, the modified polyimide electrodes are widely used in the field of permselective membranes for the electroactive species (dopamine and H₂O₂) and biosensor [22-26]. All sensor applications with polyimide as a shielding layer were done with surface acoustic wave devices(SAW's). This sensor type closely resembles the 'classic' SAW technique for chemical analysis in the gas phase [27].

2. Amperometric Polyimide Sensors

In recent years, polyimide-modified electrodes are widely used in the field of sensor and biosensor. Among the electroactive species, dopamine (DA) has been of interest to neuroscientists and chemists. A loss of DA containing neurons may result in some serious diseases such as Parkinsonism. Therefore, the determination of the concentration of this neurochemical is important. Dopamine in central nervous system coexists with ascorbic acid, whose oxidation peak potential is close to that of dopamine. Therefore, a significant problem faced in electrochemically determination of dopamine is the presence of electroactive ascorbic acid, which reduces the selectivity and sensitivity [28-30].

Ekinci and coworkers fabricated two kinds of PI membranes composed of various diamines and dianhydrides for determination of dopamine. Phosphine oxide-containing polyimides and piperazine - containing polyimides utilized to synthesize polyimides to be used as a selective membrane for dopamine in the presence of ascorbic acid. Polyimide solutions were prepared by dissolving 70 mg polyimide in 2 mL NMP. Then, polyimide films were prepared onto the Pt surface by dropping of polyimide solution and allowed to dry at room temperature for 2 days. Prior to permselectivity tests, the polyimide electrode had reached to steady state and, then the injection of electroactive substances into the PBS solution was made. The amperometric responses of the polymeric electrodes toward the electroactive substances (dopamine and ascorbic acid) were recorded as a function of time at a potential of 0,7 V vs. Ag/AgCl. The polyimides films showed excellent permselectivity behavior toward dopamine in the presence of ascorbic acid. In other words, it means that the chemically-modified polyimides can be used as dopamine-selective sensor in the presence of ascorbic acid.[21-22]

Ekinci and coworkers pyrimidine-based hyperbranched and aromatic polyimides were tested as hydrogen peroxide-selective membrane in the presence of interferents. It was found that the polyimide films can be applicable to amperometric sensing of hydrogen peroxide in the presence of the mentioned electroactive and non-electroactive interferents[23-24].

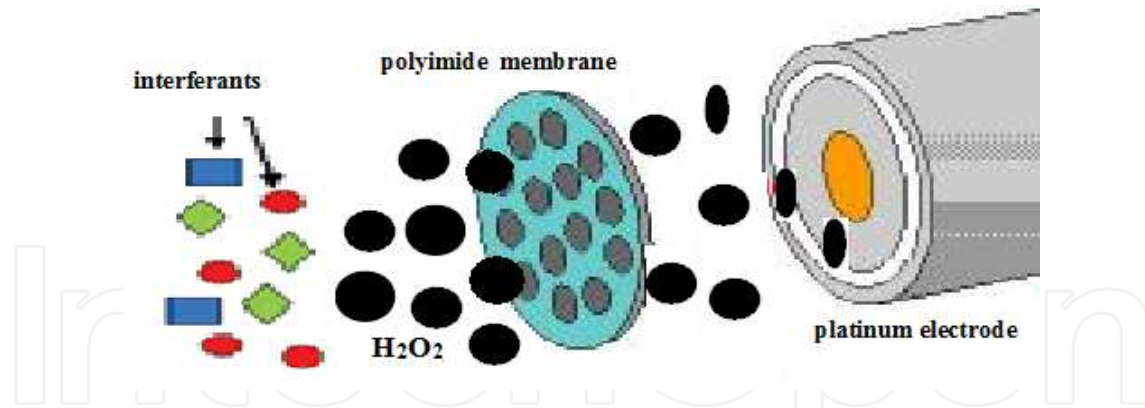
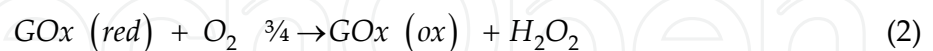
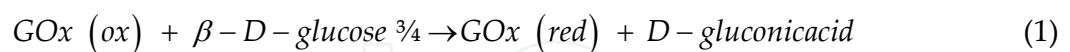

Figure 1. The preparation of the polyimide electrodes and its H_2O_2 sensing.

Since the determination of glucose in biological fluids is very important for the diagnosis and management of diabetes mellitus, the search for the ideal glucose sensor continues to be a focus of biosensor research. During the preparation of an enzyme electrode, immobilization of the enzyme at the electrode surface is a key step in the fabrication of a high-performance biosensor. However, there are several disadvantages of the enzyme-modified electrodes, such as instability, high cost of enzymes, and complicated immobilization procedure. Polymeric films have been widely used to immobilize enzymes. One of the most important problems faced in hydrogen peroxide detecting enzymatic biosensor applications is the presence of interferents. Electrochemical biosensors have found a wide range of application areas in recent decades because of their ability to combine the high specificity of biologic material with the high accuracy of electrochemical systems. The most frequently employed glucose biosensors are based on glucose oxidase (GOD). Fast, accurate, easy to-use, and specific determination of glucose level are qualities that are especially important for diabetic patients. It catalyzes the electron transfer from glucose to oxygen accompanied by the production of gluconolactone and hydrogen peroxide as represented by:



The formed hydrogen peroxide produced in the above reaction then diffuses towards the electrode surface where it is amperometrically detected by electrochemical oxidation around 0,7 V (Ag/AgCl). The quantification of glucose can be achieved via electrochemical detection of the enzymatically liberated H_2O_2 . The voltage for the oxidation/reduction of H_2O_2 at solid electrodes can be considerably reduced with the incorporation of Au and Pt nanoparticles that also allow proteins to retain their biological activity.

One of the major problems affecting most biosensors is the immobilization of the enzyme in a membrane well adherent to the electrode surface to retain its activity and to enhance the stability as longer as possible. To prevent the enzyme release a membrane was then applied on the electrode surface. The immobilization of enzyme was performed by two different

methods. In case one-step process, the polyimide solution was mixed with the GOD solution in the proportions 1:1). Later, final solution was spread onto the bare Pt electrodes and was allowed to dry in air for at least 18 h. On the other hand, for the two-step process, the GOD solution was spread onto Pt electrode and allowed to dry in air for 10–15 min. Then, the polyimide solution spread onto it and was again allowed to dry for at least 18 h. The schematic diagram of enzyme electrodes prepared by one-step process and two-step process and its glucose sensing is displayed in Scheme 1. Using the two-step process, it was suitable for immobilization of GOD. The results of study reveal that the polyimide films is very promising substrates for the immobilization and stabilization of enzymes and the development of highly stable biosensors. Polyimide films could be used as a polymeric membrane in the detection of glucose because of its selectivity and strong adherence to electrode surface and chemical stability[31-32].

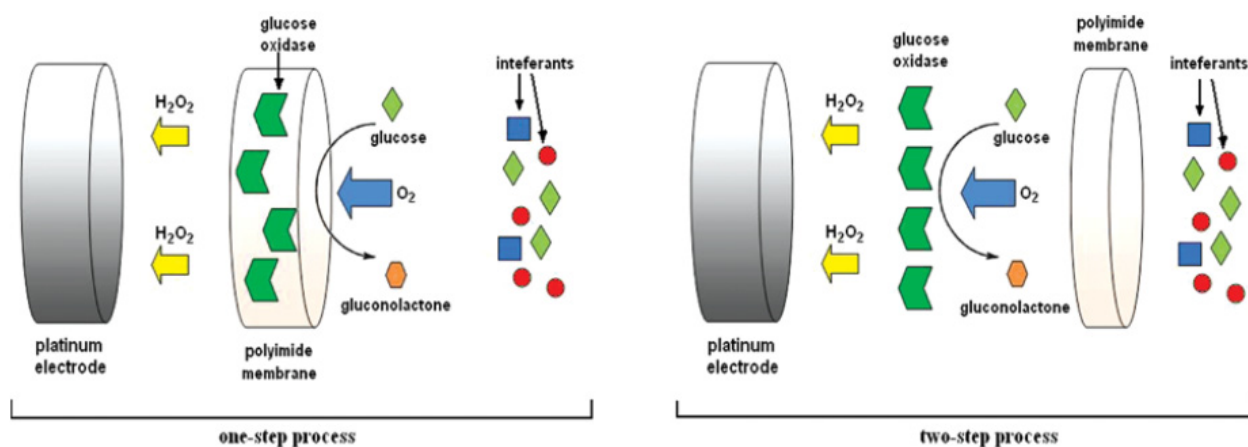

Figure 2. The preparation methods of the enzyme electrodes and their glucose sensing.

3. Polyimide gas sensors

Over the last 20 years polymeric gas separation membranes have grown from a research laboratory subject into a significant industry. In particular, polyimide membranes have been commercialized for the separation of a range of gases and considerable quantities of research has been published on the gas transport properties of these materials. Potential future uses of polyimide membranes includes the separation of carbon dioxide from flue gases for geosequestration; however, for this to become economical, significant advances in the efficiency and lifetimes of polymeric membranes will be required. In particular, polyimides have excellent intrinsic CO_2/CH_4 separation properties and have robust mechanical properties to withstand high-pressure natural gas feeds. Despite their attractive intrinsic properties, susceptibility to plasticization also causes performance declines for polyimides which negatively impacts process economics (increased methane loss) and reliability[33-34].

A commercially available polyimide, Matrimid® 5218, exhibits a combination of selectivity and permeability for industrially significant gas pairs superior to that of most other readily available polymers. Its permeation properties, combined with its processability (i.e., solubility in common solvents) makes it an ideal candidate for gas separation applications.

Furthermore, its mechanical strength and high glass transition temperature, T_g , suit it better for more rigorous working environments than polysulfone, especially in high temperature applications[35].

Past reports have also pointed out that the addition of bulky CF_3 groups in polyimide (PI) results in a good gas permeability and selectivity. Further, Hofmann et al.¹⁴ fabricated perfluorinated polymeric membranes containing different percentages of tetrafluoroethylene (TFE). In their report, they adopted positron annihilation lifetime spectroscopy (PALS) to analyze the membrane free volume and compared these data with the gas permeability. It was found that the membranes containing more TFE structures provided much greater voids and gas permeability. Hirayama et al. synthesized 32 kinds of PI membranes composed of different diamines and dianhydrides to evaluate their gas permeability. They analyzed the cohesive energy density (CED) of PI membranes and correlated these CED values with the diffusion coefficients. From their analyses, they suggested that polymer chains containing polar substituents would change the segment mobility and then control the gas diffusion mechanisms. Wang et al. also fabricated seven kinds of aromatic PI membranes composed of various diamines and dianhydrides. They noted that the bulky groups inhibited polymer chain packing and then formed a larger fractional free volume (FFV) in the membranes. The increased FFV of the membrane prompted higher gas permeability. Liu et al.¹⁸ prepared mono-PI, 6FDA-durene, 6FDA-2,6-diaminotoluene (2,6-DAT), and co-PI, 6FDA-durene/2,6-DAT membranes with various diamine ratios. They found that the increase in 6FDA-2,6-DAT in co-PI decreased the gas diffusivity and solubility, resulting in improved intrasegment packing, which lowered the gas permeation. Today, molecular simulation techniques supply a new potential method for obtaining an in-depth understanding on a molecular scale. Smit et al. analyzed the motion types of gas molecules in PI membranes using a molecular dynamics (MD) simulation. Two different types of diffusion behavior, residual time and flying time, in the membrane were observed. In addition, an increase in the temperature raised the small-molecule thermal motion and thus contributed to a higher diffusivity. Tung et al. investigated the effect of PMMA tacticity and casting solvent types on free volume morphology and the gas transport mechanisms using MD and Monte Carlo (MC) techniques. Their simulated values coincided well with the experimental data. Heuchel et al. simulated the gas permeability, solubility, and diffusivity of O_2 and N_2 in PI membranes[36].

There were two specific designs for the micro-heating elements realised on polyimide sheets, one for a resistive gas sensor and the other one for the thermal actuator. Figure 3a illustrates the design for a resistive gas sensor with the platinum electrodes and the heater patterned on the top side and on the bottom side of the 50 μm -thick polyimide sheet, respectively. This design involves simplified processing steps to realise fully flexible micro-hotplates for resistive gas sensors. However, some changes have to be brought to the standard packaging procedure of the chips on TO headers to ensure thermal insulation (by suspending the chip in air) and to be able to contact the heater on the backside of the chip. This design was fabricated but not tested due to the constraints that were just mentioned before. Another design proposed and presented in Figure 3b consists of an Upilex sheet on

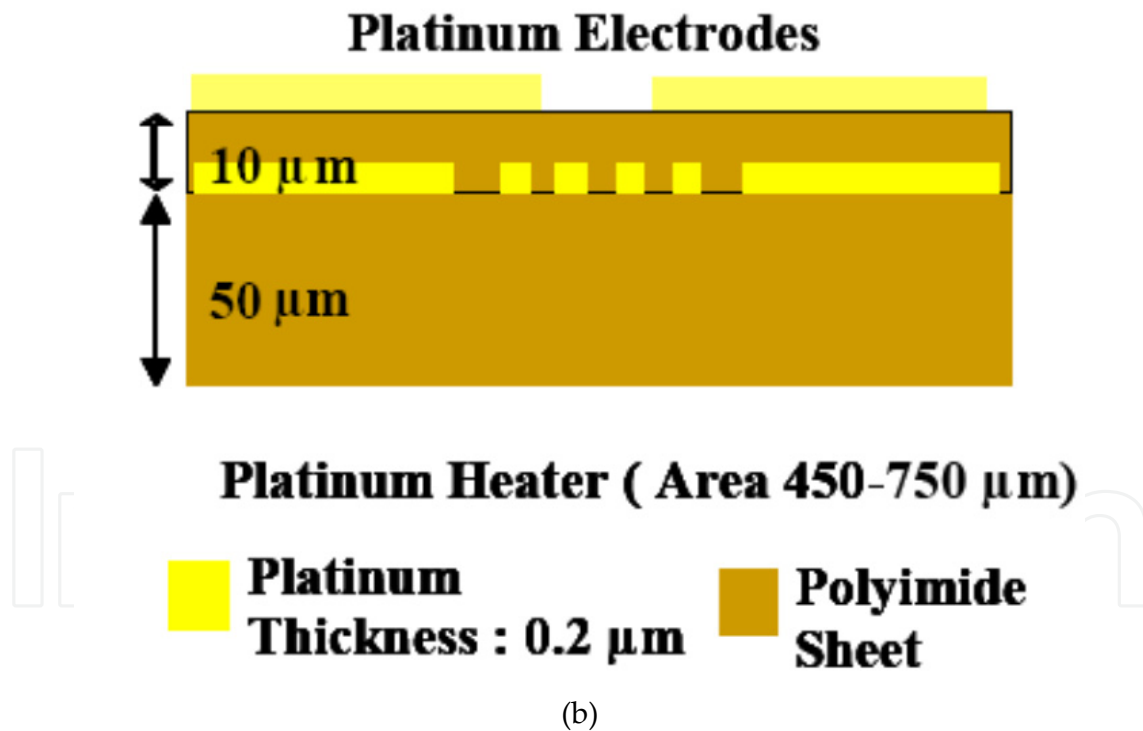
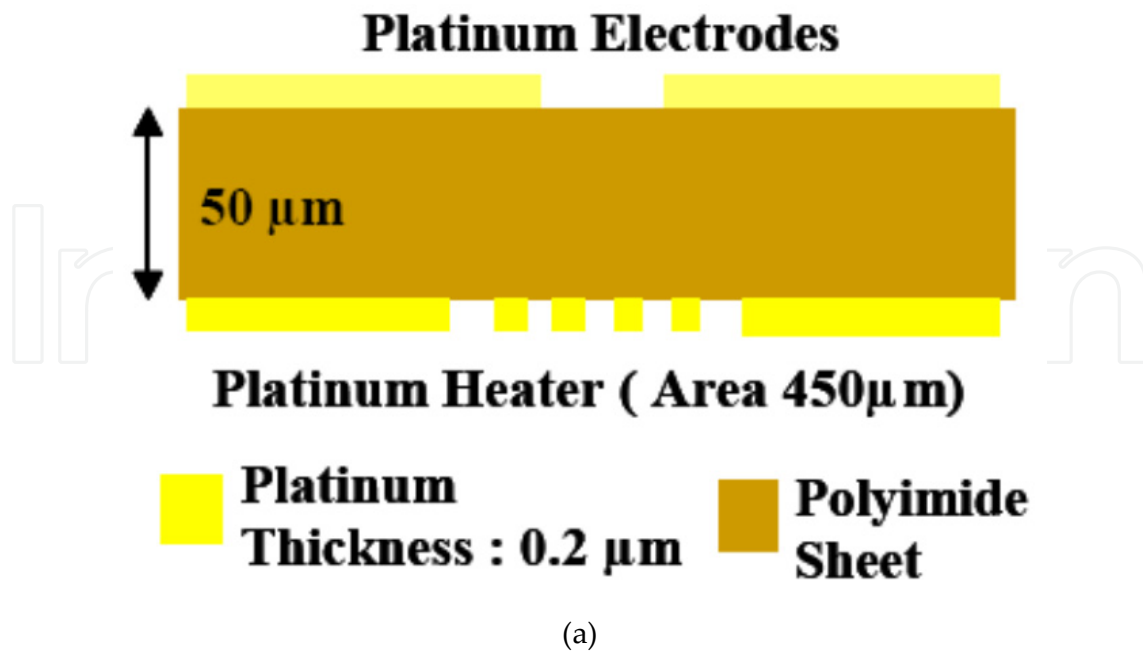

Figure 3. (a) Design of the gas sensing structure realised using the both sides of a polyimide sheet. (b) Design of the gas sensing structure realised only on the top side of the polyimide sheet[37].

which is patterned a heating element ($500\times 500\mu\text{m}^2$) covered by a $10\mu\text{m}$ -thick spin coating layer of photosensitive polyimide (PI 2731 from HD MicroSystems, $T_g > 350^\circ\text{C}$) with on top platinum electrodes. This design allows having the electrical contacts, both for the heater and the electrodes, on the same side, and therefore this design was chosen to realise

polyimide hotplates for resistive type gas sensor. The micro-hotplate design for the thermal actuator is presented in Figure 4. An aluminium film is patterned to define the heating element and the rim for the anodic bonding of the Pyrex cavity, used to store the paraffin, on the top side of a 50 μm -thick polyimide sheet. Metal to glass anodic bonding was the technique chosen to fix the Pyrex chip on the polyimide hotplate. To achieve at the same time the anodic bonding of the Pyrex chip on the Al rim and on the two interconnections of the Al heater, an Al line linking both structures has been added to the design to electrically connect them during the anodic bonding. This line was cut afterwards to allow the independent electrical operation of the heater afterwards[37].

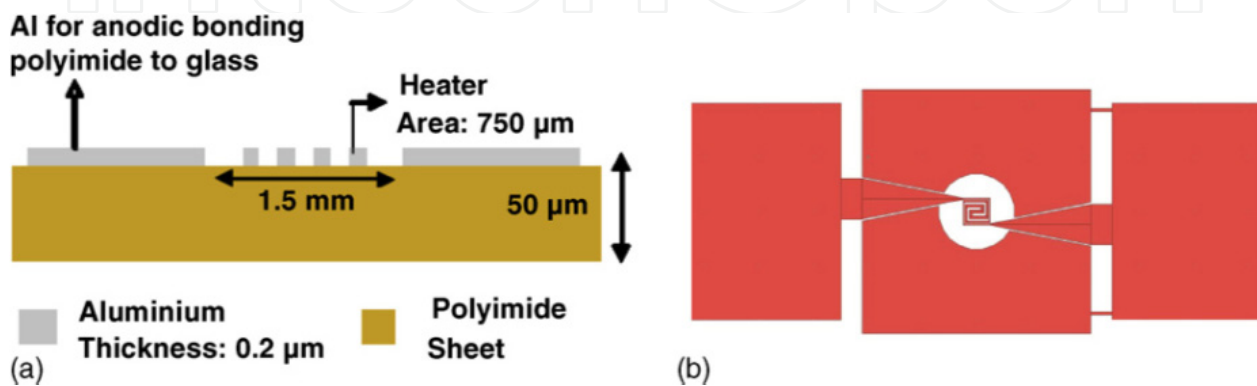

Figure 4. Design of the micro-heating element made of aluminium realised on a polyimide sheet for a thermal actuator (a) cross-section view (b) top view[37].

The calorimetric gas sensor consists of a chip-based differential set-up of a catalytically activated and a passivated temperature-sensitive thin-film resistance, introduced in [38]. If the calorimetric gas sensor is exposed in H_2O_2 atmosphere, a temperature difference between the activated and passivated resistance can be detected that is caused by the exothermal decomposition of hydrogen peroxide on the catalytic surface. In place of an active heating structure, the sensor utilizes the elevated temperature of the sterilization process. As sensor substrate, a polyimide foil (Kapton® HN from DuPont™) with a thickness of 25 μm instead of conventional silicon was envisaged due to its expedient thermal and chemical properties (low thermal conductivity and thermal endurance up to 400 $^\circ\text{C}$, ample resistance to hydrogen peroxide and to elevated humidity). Platinum with a thickness of 200 nm was deposited and photolithographically patterned as meander-shaped thin-film resistances on the polyimide foil (s. Figure 5(a)). The width of the meander-shaped paths is 40 μm and the area of one thin-film resistance amounts to be 1,0 mm^2 that results in a theoretical resistance value of 200 Ω at room temperature. The sensor was afterwards passivated with SU-8 photo resist, which is stable up to 350 $^\circ\text{C}$ as well as in highly concentrated H_2O_2 atmosphere, and catalytically activated with a dispersion of manganese(IV) oxide (Figure 5(b)). The reaction mechanisms of the H_2O_2 decomposition on the catalyst involves two pathways: i) a redox reaction with electron exchange with the catalytic surface creating free hydroxyl radicals, and ii) a chain reaction between free radicals and hydrogen peroxide in which the final products, namely water and oxygen, are formed and reaction heat is released [39-40].

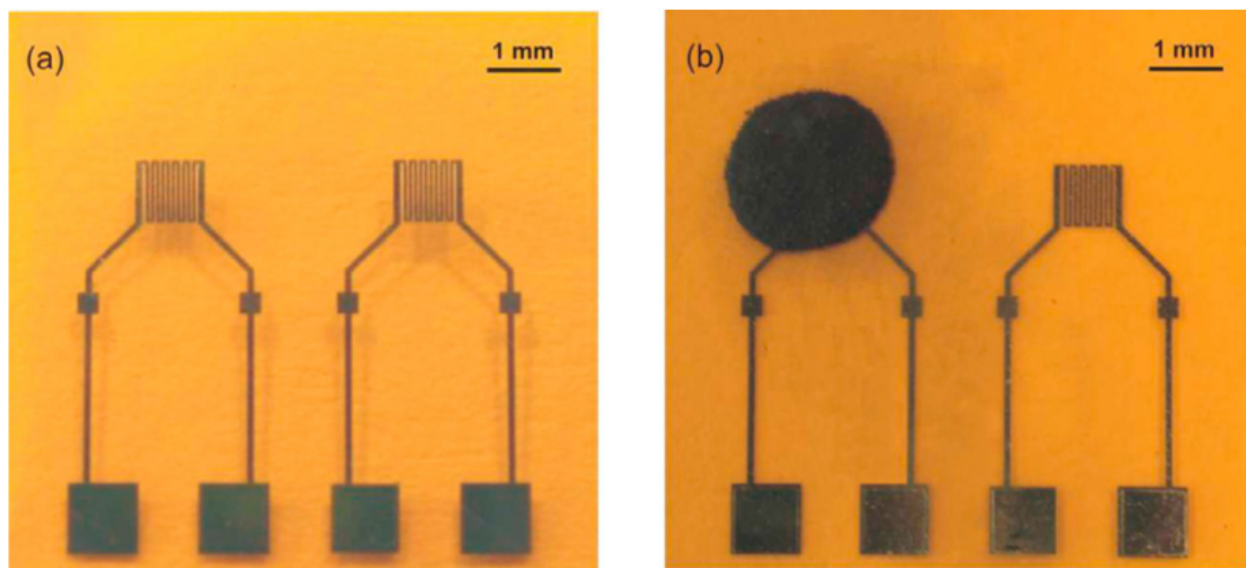

Figure 5. Calorimetric gas sensor on polyimide foil; (a) fabricated thin-film resistances with contact pads on polyimide; (b) thin-film resistances with SU-8 photo resist as passivation film and manganese(IV) oxide as catalytically active layer (chip size: $10 \times 10 \text{ mm}^2$)[40].

4. Polyimide humidity sensors

Humidity sensors have been widely used in order to make living and working environment more comfortable in our daily life including process control, meteorology, agriculture and medical equipment. Conventional humidity sensors have some drawbacks such as large volume, low sensitivity, and slow response. To overcome these drawbacks, there has been growing interest in miniaturization of humidity sensors with high performance and low fabrication cost. In this respect, micro electro mechanical system (MEMS) technology is now very popular to miniaturize humidity sensors[41].

A number of parameters have an influence on the response time of polymer-based humidity sensors, such as the dimensions of the sensor, moisture diffusivity in the film, the film thickness, and the ambient temperature. Once the sensing material is chosen, however, the response speed can only be enhanced by modifying the geometry of the device. Two different humidity sensors, Design A and Design B in Figure 6 were designed and fabricated. A high-speed capacitive humidity sensor (Design A) is achieved by introducing a micro-bridge structure with several holes created by using the front-side anisotropic and isotropic dry etching and by allowing moisture to diffuse into both top and side surfaces of polyimide film. In order to compare the sensitivity and speed, the conventional parallel-plate structure (Design B), consisting of a polyimide film and two electrodes, is designed (Figure 6b). [42]

Polyimides are compatible with IC processes and have both chemical stability and long-term stability in a presence of moisture and heat, in addition to the good hygroscopic and

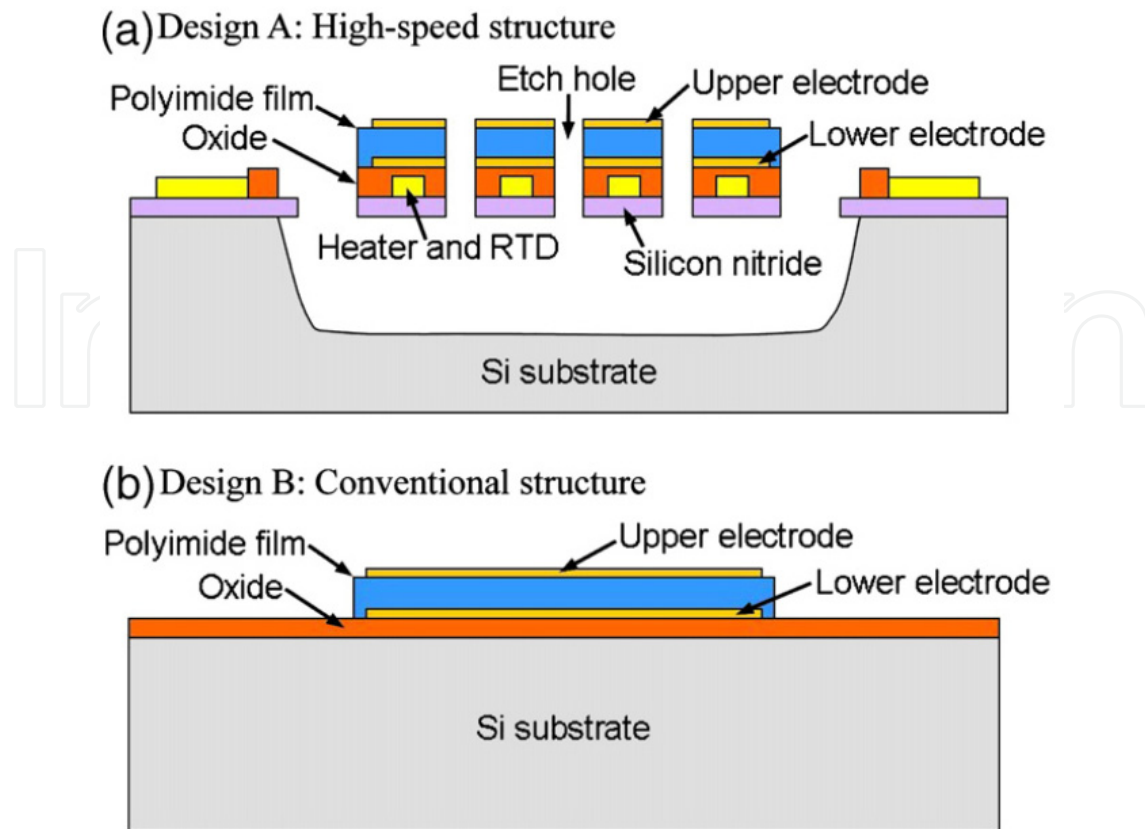

Figure 6. Schematic cross-sectional views of two capacitive humidity sensors (a) Design A: High-speed structure (b) Design B: Conventional structure[42].

dielectric properties. Therefore the capacitive type polyimide sensors have been extensively investigated. However, the typical polyimide humidity sensors suffered from slow response and substantial long-term drift and they were improved by introducing the cross-linked structure and fluorine atoms in the polyimide unit

5. Polyimide tactile sensors

Piezoelectric materials are one of the key materials utilized in tactile sensing applications. Typically, a tactile sensing array is fabricated to provide sensory feedback regarding contact with other objects or surfaces, as in Figure 7. It is desirable for many applications to be able to sense tactile information over a non-planar geometry, which requires a flexible, conformal sensor technology. One key element of a flexible sensing technology would be a polymer piezoelectric material. Previously, the only piezoelectric polymer to be applied to this technology has been PVDF [43]. PVDF has the advantages of low cost, ease of fabrication and flexibility. It's primary limitation is the its low temperature range of operation (< 80 °C). It is desirable to be able to fabricate flexible polymer tactile sensor elements that can be operated over a larger range of temperatures. PVDF is limited to less than 80 °C simply by the thermal stability of the film, causing film degradation at higher temperatures. Recent work has shown higher temperature piezoelectric response in newly developed polyimides[44].

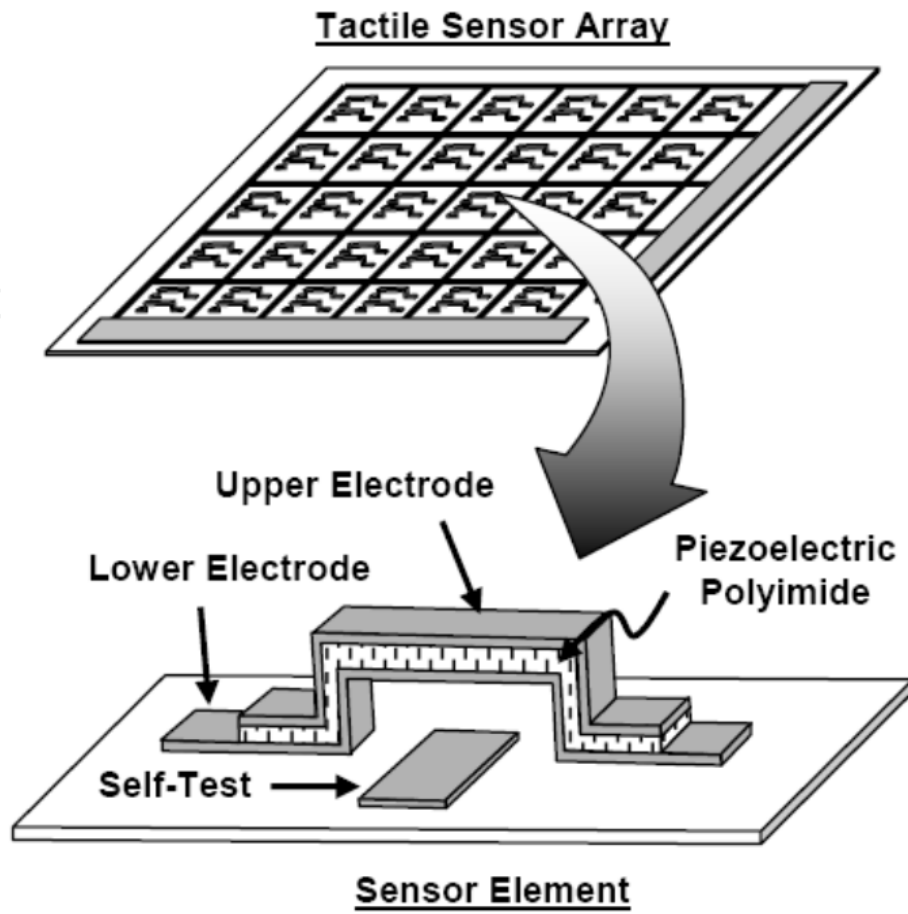

Figure 7. Tactile sensor array and an individual polyimide sensor element.[44]

Multimodal tactile sensor on flexible polyimide substrate capable of sensing the hardness, roughness, temperature and thermal conductivity of the object in contact has been developed. The sensor is constructed using a polyimide substrate (Figure 8) and consists of multiple sensor nodes arranged in an array format[45].

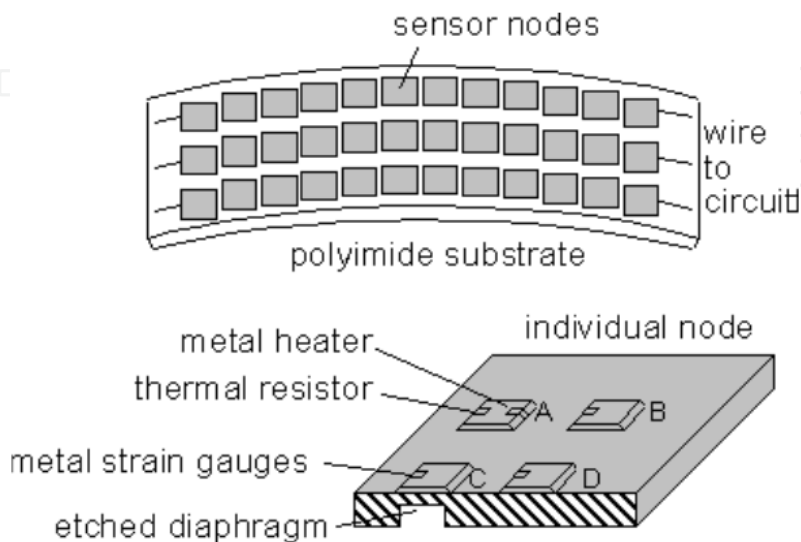

Figure 8. Schematic diagram of the polyimide multimodal tactile sensor[45].

6. Pressure sensors based polyimide

Kapton is an example of an insulating polymer that can be laser-carbonized to form conducting filaments. This substrate is flexible, inexpensive, durable and easy to manufacture. While the Kapton polyimide is a good insulator, research has shown that the laser-carbonized filaments are fair conductors. Additional opportunities to increase the effectiveness of some sensor designs lie in the fact that the carbonized filaments are porous and their resistivity can be manipulated easily during processing[46].

The fabrication sequence of the capacitive pressure sensor array is illustrated in Figure 9. The process starts on square, stainless steel substrates that are each 5.7 cm on a side, 0.5 mm thick, and have surface roughness of approximately 6–8 μm . An array of 8×8 pressure inlet holes with a diameter of 2 mm, with 5mm center-to-center distances, is milled through the stainless steel substrate. Kapton polyimide film (Dupont, Kapton HN200, 50 μm thick) is laminated onto the milled stainless steel substrate using a hot press with a pressure of 8.65 MPa and a temperature of 175 °C for 30 min. The pressure-sensitive diaphragms will be the Kapton polyimide film in the regions suspended over the milled pressure inlet holes (Figure 9a). A triple metallic layer of Ti/Cu/Ti with a thickness of 100/2000/500Å is deposited by electron-beam evaporation and then patterned using a lift-off process to create bottom electrodes, electroplating seed layers, and bonding pads on the surface of the Kapton polyimide film (Figure 9a). Multiple layers of PI2611 polyimide (Dupont) are spun onto the patterned layer with a spin speed of 1200 rpm for 60 s, and hard-cured in a N₂ ambient at 200 °C for 120 min yielding a final thickness of polyimide of approximately 44–48 μm . The polyimide layer is anisotropically etched using reactive ion etching to create electroplating molds for the support posts of the fixed backplates, and to remove the uppermost titanium layer of the seed layer (Figure 9b). Nickel supports are then electroplated through the polyimide molds. A Ti/Cu/Ti metallic triple layer with a thickness of 300/2000/300Å is deposited using DC sputtering to act as a seed layer for the deposition of the backplate. Thick photoresist (Shipley SJR 5740) is spun on the seed layer with a spin speed of 1100 rpm for 30 s (yielding a final thickness of approximately 15 μm) and patterned to act as electroplating molds for the backplates. After removal of the uppermost Ti layer, nickel is electroplated through the thick photoresist electroplating molds to create the backplates (Figure 9). The thick photoresist electroplating molds and the remaining seed layer are removed. Finally, the polyimide molds for the backplate posts as well as polyimide sacrificial layers are isotropically etched to create air gaps between the fixed backplates and the pressure sensitive Kapton polyimide flexible diaphragms (Figure 9d and 9c). The isotropic dry etch is carried out in a barrel plasma etcher using CF₄/O₂ plasma with a RF power of 120W. Figure 9 illustrates photographs of a fabricated pressure sensor array, where (b) shows a side-view and (c) shows a close-up view of the gap defined between the fixed backplate and the diaphragm. Note that these sensors are operating in differential mode, with the side containing the backplate held at a pressure of 1 atm[47].

The readout are connected to a hydraulic restriction. The key processes of the device are a thermal bonding of a polyimide sheet to an already micromachined silicon wafer and the deposition of transducers onto the polyimide membrane. A schematic cross section is

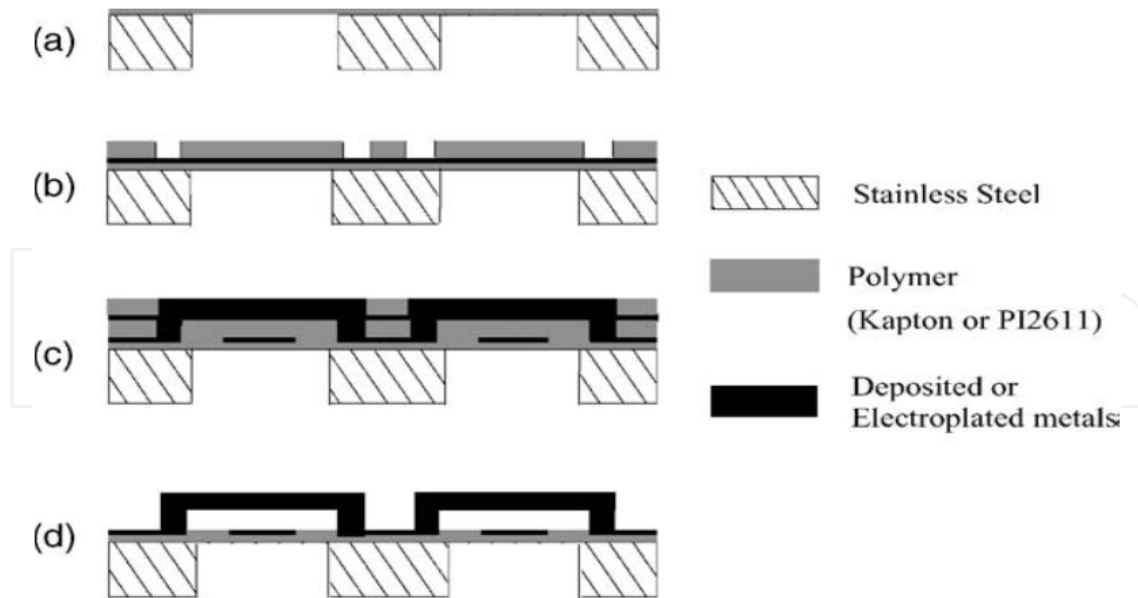

Figure 9. Fabrication sequence of pressure sensor based on Kapton polyimide diaphragm.

depicted in figure 10. The ZnO sensing layout is a ring on the top of a circular pressure membrane. The size of the ring is designed in such a manner that the piezoelectric ZnO layer is only under compressive strain. Highest sensitivity is reached by the ring arrangement because the compressive strain at the edge of the membrane is high and the electrode surface is large compared to other configurations. The top view of a fabricated ZnO piezoelectric transducer is shown in figure 11. The diameter of the pressure sensing membrane is 1 mm with a thickness of 25 μm . devices have been fabricated by using standard MEMS technologies. Two pressure sensors with piezoelectric[48].

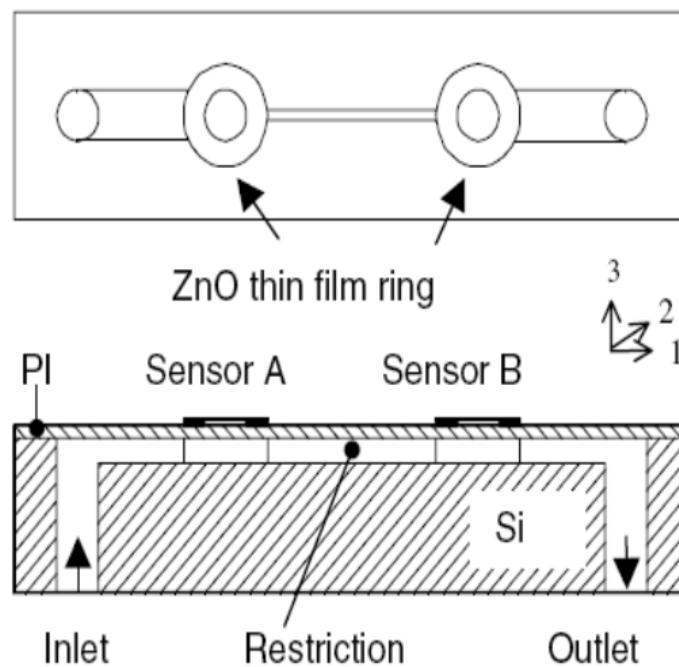

Figure 10. Schematic view of the device[48].

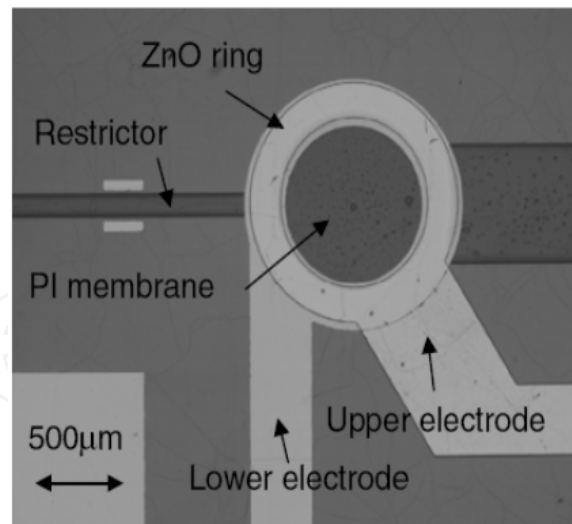

Figure 11. Top view of a pressure sensor[48].

7. Conclusions

Polyimides have excellent thermal stability, solvent resistance, radiation resistance, wear resistance, hydrolytic stability, low dielectric constant, high mechanical properties, good chemical resistance and a low dielectric constant. Due to these superior properties, the application field of polyimide has generally been enlarged from printed circuit boards and electrical insulation layers in microelectronics to functional layers of humidity sensors, shielding layers for sensor surfaces and novel platforms for thermal sensor devices, temperature sensor arrays, micro-hotplates integrated into gas sensors and biosensors.

Author details

Aziz Paşahan

İnönü University, Faculty of Sciences and Literature, Department of Chemistry, Malatya, Turkey

8. References

- [1] Koytepe S, Vural S, Seckin T (2009) Molecular design of nanometric zinc borate-containing polyimide as a route to flame retardant materials. *Mater. Res. Bull.* 44: 369–376.
- [2] Ghosh MK, Mittal KL (1996) *Polyimides: fundamentals and applications*. New York: Marcel Dekker. 126–130 pp.
- [3] Mittal KL (1984) *Polyimides: synthesis, characterization and applications*. New York: Plenum Press. 1–10 pp.
- [4] Wilson D, Stenzenberger HD, Hergenrother PM (1990) *Polyimides*. New York: Blackie. 1–21 pp.

- [5] Xu JJ, Zhang XQ, Yu ZH, Fang HQ, Chen HY (2001) A stable glucose biosensor prepared by co-immobilizing glucose oxidase into poly(p-chlorophenol) at a platinum electrode. *Fresenius J Anal Chem.* 369:486-490.
- [6] Eldin MSM, De Maio, A, Di Martino, S, Bencivenga, U, Rossi, S, Duva, A, Gaeta, FS, Mita DG (1999) Immobilization of b-Galactosidase on Nylon Membranes Grafted with Diethylenglycol Dimethacrylate (DGDA) by g-Radiation: Effect of Membrane Pore Size. *Advances in Polymer Technology.* 18:109-123.
- [7] kinci E, Köytepe, S, Pasahan, A, Seckin T (2006) Preparation and characterization of an aromatic polyimide and its use as a selective membrane for H₂O₂. *Turk. J. Chem.* 30:277-285.
- [8] Abasıyanık MF, Mehmet S (2010) Immobilization of glucose oxidase on reagentless ferrocene-containing polythiophene derivative and its glucose sensing application. *J. Electroanal. Chem.* 639:21-26.
- [9] aby TT, Aravind SSJ, Arockiadoss T, Rakhi RB, Ramaprabhu S (2010) Metal decorated graphene nanosheets as immobilization matrix for amperometric glucose biosensor. *Sens. Actuat. B-Chem.* 145:71-77.
- [10] Chi Q, Dong S (1993) Flow-injection analysis of glucose at an amperometric glucose sensor based on electrochemical codeposition of palladium and glucose oxidase on a glassy carbon electrode. *Anal. Chim. Acta.* 278:17-23.
- [11] Yu JH, Liu SQ, Ju HX (2003) Glucose sensor for flow injection analysis of serum glucose based on immobilization of glucose oxidase in titania sol-gel membrane. *Biosens. Bioelectron.* 19, 401-409.
- [12] Cosnier, S, Fombon, JJ, Labbe P, Limosin D (1999) Development of a PPO-poly(amphiphilic pyrrole) electrode for on site monitoring of phenol in aqueous effluents. *Sens. Actuator B-Chem.* 59:134-139.
- [13] Ghaemy M, Nasab SMA (2010) Synthesis and identification of organosoluble polyimides: Thermal, photophysical and chemiluminescence properties. *Polym. J.* 42:648-656.
- [14] Chou WY, Kuo CW, Chang CW, Yeh BL, Chang MH (2010) Tuning surface properties in photosensitive polyimide. *Material design for high performance organic thin-film transistors. J. Mater. Chem.* 20: 5474-5480.
- [15] Jiang LZ, Liu JG, Wu DZ, Li HQ, Jin RG (2006) A methodology for the preparation of nanoporous polyimide films with low dielectric constants. *Thin Solid Films* 510, 241-246.
- [16] Jin XZ, Ishii H (2005) Novel positive-type photosensitive polyimide with low dielectric constant. *J. Appl. Polym. Sci.* 98:15-21.
- [17] Ba CY, Economy J (2010) Preparation of PMDA=ODA polyimide membrane for use as substrate in a thermally stable composite reverse osmosis membrane. *J. Membr. Sci.* 363: 140-148.
- [18] Yoon SJ, Choi JH, Hong YT, Lee SY (2010) Synthesis and characterization of sulfonated Poly(arylene ether sulfone) ionomers incorporating perfluorohexylene units for DMFC membranes. *Macromol. Res.* 18:352-357.

- [19] Darvishmanesh S, Degreve J, Van der Bruggen B (2010) Performance of solvent-pretreated polyimide nanofiltration membranes for separation of dissolved dyes from toluene. *Ind. Eng. Chem. Res.* 49:9330–9338.
- [20] Chang WY, Fang TH, Lin YC (2008) Physical characteristics of polyimide films for flexible sensors. *Appl Phys. A* 92: 693–701.
- [21] Paşahan A, Köytepe S, Ekinci E, Seçkin T (2004) Synthesis, Characterization and Dopamine Selectivity of 1,4-bis(3-aminopropyl)piperazine-Containing Polyimide. *Polymer Bulletin.* 51:351-358.
- [22] Köytepe S, Paşahan A, Ekinci E, Alıcı B, Seçkin T (2008) Synthesis, characterization of phosphine oxide-containing polyimides and their use as selective membrane for dopamine. *Journal Polymer Research.* 15:249-257.
- [23] Köytepe S, Paşahan A, Ekinci E, Seçkin T (2005) Synthesis, characterization and H₂O₂-sensing properties of pyrimidine-based hyperbranched polyimides. *European Polymer Journal.* 41:121-127.
- [24] Ekinci E, Köytepe S Paşahan A, Seçkin T (2006) Preparation and Characterization of an Aromatic Polyimide and Its Use as a Selective Membrane for H₂O₂. *Turkish Journal Of Chemistry.* 30:277-285.
- [25] Ekinci E, Emre FB, Köytepe S, Seçkin T (2005) Preparation, characterization and H₂O₂ selectivity of hyperbranched polyimides, containing triazine. *J.Polym. Res.* 12:205-210.
- [26] Paşahan A, Köytepe S, Ekinci E (2011) Synthesis, characterization of poly(4, 4'-diaminophenylethanepyromellitimide) and its use as immobilized enzyme polyimidemembrane. *High Perform Polym.* 23:59-65.
- [27] Rapp M, Boss B, Voight A, Gemmeke HJ, Ache HJ (1995) Development of an analytical microsystem for organic gas detection based on surface acoustic wave resonators, *Fresenius J. Anal. Chem.* 352: 699–704.
- [28] Ciszewski A, Milczarek G (1999) Polyeugenol-modified platinum electrode for selective detection of dopamine in the presence of ascorbic acid *Anal Chem* 71:1055–1061
- [29] Kaneko H, Yamada M, Aoki K (1990) Determination of Dopamine in Solution of Ascorbic Acid at Graphite-Reinforcement Carbon Electrodes by Differential Pulse Voltammetry) *Anal Sci* 6:439–442
- [30] Niwa O, Morita M, Tabei H (1991) Highly sensitive and selective voltammetric detection of dopamine with vertically separated interdigitated array electrodes *Electroanalysis* 3:163–168.
- [31] Pasahan A, Köytepe S, Ekinci E (2011) Synthesis, Characterization of a New Organosoluble Polyimide and Its Application in Development of Glucose Biosensor. *Polymer-Plastics Technology and Engineering* 50: 1239–1246.
- [32] Pasahan A, Köytepe S, Ekinci E (2011) Synthesis, characterization of naphthalene based polyimides and their use as immobilized enzyme membrane. *Polym. Advan. Technol.* 22:1940–1947.
- [33] Wind JD, Paul DR, Koros WJ (2004) Natural gas permeation in polyimide membranes. *Journal of Membrane Science.* 228: 227–236.

- [34] Powell CE, Xavier J, Duthie XJ, Kentish SE, Qiao GG, Stevens GW (2007) Reversible diamine cross-linking of polyimide membranes *Journal of Membrane Science* 291: 199–209
- [35] Ekiner OM, Hayes RA, Manos P (1992) Novel multicomponent fluid separation membranes, US Patent 5,085,676, E.I. du Pont de Nemours.
- [36] Chang KS, Tung CC, Wang KS, Tung KL (2009) Free Volume Analysis and Gas Transport Mechanisms of Aromatic Polyimide Membranes: A Molecular Simulation Study *J. Phys. Chem. B.* 113:9821–9830.
- [37] Briand D, Colin S, Gangadharaiah A, Velab E, Dubois P, Thiery L, de Rooij NF (2006) Micro-hotplates on polyimide for sensors and actuators. *Sensors and Actuators A* 132:317–324.
- [38] Nather N, Henkel H, Schneider A, Schöning MJ (2009) Investigation of different catalytic active and passive materials for the realisation of a hydrogen peroxide gas sensor. *Phys.Status Solidi A* 206:449-54.
- [39] Hiroki A, LaVerne JA (2005) Decomposition of hydrogen peroxide at water-ceramic oxide interfaces. *J. Phys. Chem. B.*109:3364-70.
- [40] Kirchner P, Oberländer J, Friedrich P, Berger J, Rysstad G, Keusgen M, Schöning MJ (2010) Realization of a calorimetric gas sensor on polyimide foil for applications in aseptic food industry, *Procedia Engineering.* 5:264–267.
- [41] Kim JH, Hong SM, Moon BM, Kim K (2010) High-performance capacitive humidity sensor with novel electrode and polyimide layer based on MEMS technology, *Microsyst Technol* 16:2017–2021
- [42] Kim JS, Lee MY, Kang MS, Yoo KP, Kwon KH, Singh VR, Min NK (2010) Fabrication of high-speed polyimide-based humidity sensor using anisotropic and isotropic etching with ICP. *Thin Solid Films, Procedia Engineering* 5:264–267
- [43] Ounaies Z, Harrison JS (2002) An Investigation of Piezoelectricity of a Nitrile-Substituted Polyimide. *Journal of Polymer Science. Polymer Physics.*
- [44] Atkinson GM, Pearson RE, Ounaies, Z Park C, Harrison JS, Midkiff JA (2003) Piezoelectric Polyimide Tactile Sensors.
- [45] By Chang Liu, (2007) Recent Developments in Polymer MEMS, *Adv. Mater.* 19:3783–3790
- [46] Ingram JM, Grep M, Nicholson JA, Fountain AW (2003) Polymeric humidity sensor based on laser carbonized polyimide substrate *Sensors and Actuators B* 96:283–289
- [47] Chang SP, Allen MG (2004) Demonstration for integrating capacitive pressure sensors with read-out circuitry on stainless steel substrate. *Sensors and Actuators A.* 116:195–204.
- [48] Kuoni A, Holzherr R, Boillat M, de Rooij NF (2003) Polyimide membrane with ZnO piezoelectric thin film pressure transducers as a differential pressure liquid flow sensor. *J. Micromech. Microeng.* 13:103–107