

We are IntechOpen, the world's leading publisher of Open Access books Built by scientists, for scientists

4,800

Open access books available

122,000

International authors and editors

135M

Downloads

Our authors are among the

154

Countries delivered to

TOP 1%

most cited scientists

12.2%

Contributors from top 500 universities



WEB OF SCIENCE™

Selection of our books indexed in the Book Citation Index
in Web of Science™ Core Collection (BKCI)

Interested in publishing with us?
Contact book.department@intechopen.com

Numbers displayed above are based on latest data collected.

For more information visit www.intechopen.com



Dispersion Relations and Modal Patterns of Wave in a Cylindrical Shell

Yu-Cheng Liu, Yun-Fan Hwang and Jin-Huang Huang

Additional information is available at the end of the chapter

<http://dx.doi.org/10.5772/50477>

1. Introduction

The dispersion relation of a circular cylindrical shell had been a subject of great interest for several decades [1-3]. In some earlier works, numerical procedures were used exclusively in the computation of dispersion relations. Recently, Karczub [4] obtained an analytical expression for the dispersion relations from Flügge shell theory by using a symbolic algebra package, Mathematica. Karczub's main concern was to check the agreement between his analytical results and results obtained previously from numerical methods, and limited to the harmonic orders $n \geq 1$. The agreement was excellent. The axisymmetric waves ($n=0$) are important in the transmission of longitudinal waves, and are particularly important in acoustics due to their high radiation efficiency. In order to have complete analytical solutions for the shell dispersion relations, the solutions for the $n=0$ case are included and discussed in this paper.

The solutions of the modal patterns for each of the propagating and non-propagating modes are also important and are not discussed in Karczub's paper. These solutions are crucial to determine the vibration of a finite shell under various admissible boundary conditions and arbitrary external forces. The dispersion relations and the associated eigenvectors are also the means by which to construct transfer matrices for vibroacoustic transmission in cylindrical shell structures or pipe-hose systems [5]. The traditional and standard method of finding eigenvectors was given in detail by Leissa [6]; the eigenvector was normalized in such a way that its radial component of the displacement was unity, while the longitudinal and circumferential components were expressed as displacement ratios relative to the radial displacement. In some cases, these ratios could become exceedingly large and the eigenvector thus could deviate significantly from the eigenvector commonly used in mathematical physics.

In order to improve this problem for finding the normalized eigenvectors with norms equal to unity, an alternative method by using the built-in eigenvalue problem in any numerical package is proposed. A continuous variation of mode patterns for all kind of wave types in

the desired frequency range will be rapidly obtained, and the physical meanings of wave propagation can also be shown more clearly and straightforward [8].

2. Methods to determine the propagating mode wavenumbers

2.1. Expression of equation of motion of cylindrical shell

The coordinate system which $\{u, v, w\}$ are presented as the axial, circumferential, and radial direction, respectively, is shown in Fig. 1.

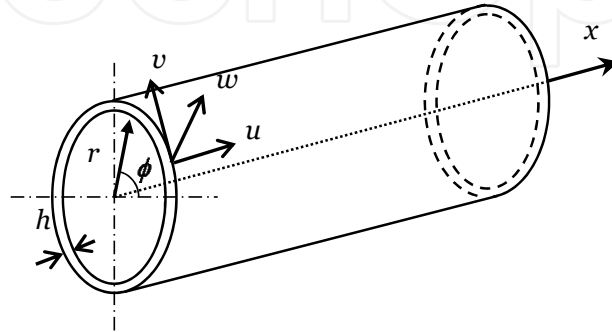

Figure 1. Coordinates and displacement orientation.

The equations of motion for the free vibration of a cylindrical shell can be written and shown as below

$$\begin{bmatrix} \tilde{L}_{11} & \tilde{L}_{12} & \tilde{L}_{13} \\ \tilde{L}_{21} & \tilde{L}_{22} & \tilde{L}_{23} \\ \tilde{L}_{31} & \tilde{L}_{32} & \tilde{L}_{33} \end{bmatrix} + \frac{\rho(1-\nu^2)}{E} \frac{\partial^2}{\partial t^2} \begin{bmatrix} 1 & 0 & 0 \\ 0 & 1 & 0 \\ 0 & 0 & 1 \end{bmatrix} \begin{Bmatrix} u(x, \phi, t) \\ v(x, \phi, t) \\ w(x, \phi, t) \end{Bmatrix} = \begin{Bmatrix} 0 \\ 0 \\ 0 \end{Bmatrix} \quad (1)$$

where \tilde{L}_{ij} , $(i, j)=1\sim 3$, are the spatial operators by using the Flügge theory. These parameters can be listed as below

$$\begin{aligned} \tilde{L}_{11} &= -\frac{\partial^2}{\partial x^2} - \frac{(1+\beta^2)(1-\nu)}{2a^2} \frac{\partial^2}{\partial \phi^2}, \quad \tilde{L}_{12} = -\frac{1+\nu}{2a} \frac{\partial^2}{\partial x \partial \phi} \\ \tilde{L}_{13} &= -\frac{\nu}{a} \frac{\partial}{\partial x} + \beta^2 a \frac{\partial^3}{\partial x^3} - \beta^2 \frac{1-\nu}{2a} \frac{\partial^3}{\partial x \partial \phi^2} \\ \tilde{L}_{21} &= \tilde{L}_{12}, \quad \tilde{L}_{22} = -\frac{(1-\nu)(1+3\beta^2)}{2} \frac{\partial^2}{\partial x^2} - \frac{1}{a^2} \frac{\partial^2}{\partial \phi^2}, \\ \tilde{L}_{23} &= -\frac{1}{a^2} \frac{\partial}{\partial \phi} + \beta^2 \frac{(3-\nu)}{2} \frac{\partial^3}{\partial x^2 \partial \phi} \\ \tilde{L}_{31} &= -\tilde{L}_{13}, \quad \tilde{L}_{32} = -\tilde{L}_{23}, \\ \tilde{L}_{33} &= \frac{1}{a^2} + \beta^2 \left(a^2 \frac{\partial^4}{\partial x^4} + 2 \frac{\partial^4}{\partial x^2 \partial \phi^2} + \frac{1}{a^2} \frac{\partial^4}{\partial \phi^4} \right) + \left(\frac{\beta}{a} \right)^2 \left(1 + 2 \frac{\partial^2}{\partial \phi^2} \right) \end{aligned} \quad (2)$$

where a is the mean shell radius, ν is Poisson ratio, E is Young's modulus of elasticity, ρ is the mass density, h is the shell thickness, and $\beta=h/(a(12)^{0.5})$ is a non-dimensional thickness parameter which is proportional to the ratio between the thickness and radius.

In order to transfer the expression from time and displacement domain into frequency and wavenumber domain, the following spectral representation can be further to use [7]

$$f(x, \phi, t) = \sum_{n=-\infty}^{\infty} e^{in\phi} \int_{-\infty}^{\infty} \int_{-\infty}^{\infty} F(\alpha, n, \omega) e^{i(\alpha x - \omega t)} d\alpha d\omega \quad (3)$$

The dimensionless spectral listed in Eq.(1) can becomes as following

$$\left\{ \begin{bmatrix} L_{11}(s, n) & L_{12}(s, n) & L_{13}(s, n) \\ L_{12}(s, n) & L_{22}(s, n) & L_{23}(s, n) \\ -L_{13}(s, n) & -L_{23}(s, n) & L_{33}(s, n) \end{bmatrix} - \Omega^2 \begin{bmatrix} 1 & 0 & 0 \\ 0 & 1 & 0 \\ 0 & 0 & 1 \end{bmatrix} \right\} \cdot \begin{bmatrix} U(s, n, \Omega) \\ V(s, n, \Omega) \\ W(s, n, \Omega) \end{bmatrix} \cdot e^{i(\alpha x - \omega t)} \cdot e^{in\phi} = 0 \quad (4)$$

where $\Omega=(\omega a/c_L)$ is the dimensionless frequency, $c_L=[E/(\rho(1-\nu^2))]^{0.5}$ is the longitudinal wave speed, $s=\alpha a$ is the dimensionless wavenumber, and n is the circumferential wavenumber, respectively. L_{ij} , $(i,j)=1\sim 3$, are the spectral spatial operators and listed as follow

$$\begin{aligned} L_{11} &= s^2 + [(1-\nu)/2](1+\beta^2)n^2, & L_{12} &= n[(1+\nu)/2]s \\ L_{13} &= -i \left\{ \nu - [(1-\nu)/2]\beta^2 n^2 \right\} s + \beta^2 s^3, & L_{22} &= [(1-\nu)/2](1+3\beta^2)s^2 + n^2 \\ L_{23} &= -i \left\{ n + n[(3-\nu)/2]\beta^2 s^2 \right\}, & L_{33} &= [1+\beta^2(1-2n^2)] + \beta^2 (s^4 + 2n^2 s^2 + n^4) \end{aligned}$$

2.2. Analytical expressions for dispersion relations

The relationship between s and Ω is so called dispersion relations of cylindrical shell. When a value of dimensionless angular frequency, Ω , is given, non-trivial solutions for the matrix form in the Eq.(4) exist at certain values of s . Finally, the specified roots can be integrated to the polynomial of s^2 . All the calculating processes and expressions can be rapidly built up by using any kind of symbolic algebra package, such as Matlab or Mathematica. According the physical characteristics of acoustic propagation, two conditions can further be separated and discussed as following.

2.2.1. $n=0$

When $n=0$, two independent sets of equations and corresponding characteristic equation can be calculated and shown as below:

1. For axial and radial displacements:

$$\left\{ \begin{bmatrix} L_{11}(s, n) & L_{13}(s, n) \\ -L_{13}(s, n) & L_{33}(s, n) \end{bmatrix} - \Omega^2 \begin{bmatrix} 1 & 0 \\ 0 & 1 \end{bmatrix} \right\} \cdot \begin{bmatrix} U(s, 0, \Omega) \\ W(s, 0, \Omega) \end{bmatrix} = 0 \quad (5)$$

For the non-trivial solution for $\{U(s,0,\Omega), W(s,0, \Omega)\}$, the determinant of matrix in Eq. (5) should be zero and obtained as below:

$$g_6(s^2)^3 + g_4(s^2)^2 + g_2(s^2) + g_0 = 0 \tag{6}$$

where the coefficients, g_i , are the function of n and Ω , and shown as

$$\begin{aligned} g_6 &= \beta^2(1 + \beta^2) \quad , \quad g_4 = \beta^2(2\nu - \Omega^2), \\ g_2 &= 1 + \beta^2 + \nu^2 - \Omega^2 \quad , \quad g_0 = \Omega^2(\Omega^2 - \beta^2 - 1) \end{aligned}$$

The solutions of Eq.(5) represent a combination of longitudinally and radially expanding and contracting motions; these are the so-called breathing-modes. The expressions of polynomial s^2 is obtained in Eq.(6).

Six characteristic roots are given

$$\begin{aligned} \text{Branch pair 1 : } s &= \pm\sqrt{\Gamma_1 + 2\Gamma_2} \\ \text{Branch pair 2 : } s &= \pm\sqrt{\Gamma_1 - \Gamma_2 + (\sqrt{3}\Gamma_3)i} \\ \text{Branch pair 3 : } s &= \pm\sqrt{\Gamma_1 - \Gamma_2 - (\sqrt{3}\Gamma_3)i} \end{aligned} \tag{7}$$

where

$$\begin{aligned} \Gamma_1 &= -g_4 / (3g_6) \quad , \quad \Gamma_2 = \Lambda_2 - \Lambda_3 \quad , \quad \Gamma_3 = \Lambda_2 + \Lambda_3 \\ \Lambda_1 &= \left(\lambda_2 + \sqrt{4\lambda_1^3 + \lambda_2^2}\right)^{1/3} \quad , \quad \Lambda_2 = \Lambda_1 / \left(6g_6 2^{(1/3)}\right) \quad , \quad \Lambda_3 = \lambda_1 / \left(3g_6 \Lambda_1 2^{(2/3)}\right) \\ \lambda_1 &= -g_4^2 + 3g_2g_6 \quad , \quad \lambda_2 = -2g_4^3 + 9g_2g_4g_6 - 27g_0g_6^2 \end{aligned}$$

2. For the circumferential displacement:

The 2nd equation in Eq. (4) can be separated and shown as:

$$\left\{L_{22}(s, n) - \Omega^2\right\} \cdot [V(s, 0, \Omega)] = 0 \tag{8}$$

In the same way, under the non-trivial solution for $V(s,0,\Omega)$, the new relation can be rewritten as

$$\left[(1 - \nu)(1 + 3\beta^2) / 2 \right] s^2 - \Omega^2 = 0 \tag{9}$$

Obviously, the solution of Eq.(8) represents a uniformly circumferential motion, which is therefore a torsional-mode. The corresponding characteristic roots may be considered the 4th branch pair and show as following

$$\text{Branch pair 4 : } s = \pm\Omega / \sqrt{(1 - \nu)(1 + 3\beta^2) / 2} \tag{10}$$

This torsional waves are known for being non-dispersive, since the wave speed is

$$c_T = \omega / \alpha = c_L \Omega / s = c_S \sqrt{1 + 3\beta^2}$$

where c_S is the shear wave speed. When the thickness is approximated to zero, torsional wave and shear wave speed will almost be the same. Therefore, in Flügge's theory, the shear wave speed depends slightly on the thickness and radius ratio.

2.2.2. $n \geq 1$

Under the non-trivial solution of Eq. (4), a 4th polynomial of s^2 can be obtained as

$$g_8(s^2)^4 + g_6(s^2)^3 + g_4(s^2)^2 + g_2(s^2) + g_0 = 0 \quad (11)$$

These roots yield eight branches of dispersion curves, which are grouped into four branch pairs:

$$\begin{aligned} \text{Branch pair 1: } s &= \pm (A_1 + A_2 + A_4)^{1/2} \\ \text{Branch pair 2: } s &= \pm (A_1 + A_2 - A_4)^{1/2} \\ \text{Branch pair 3: } s &= \pm (-A_1 + A_2 + A_4)^{1/2} \\ \text{Branch pair 4: } s &= \pm (-A_1 + A_2 - A_4)^{1/2} \end{aligned} \quad (12)$$

where g_i and A_i are the coefficients and listed in the Appendix. Since A_i 's are functions of n and Ω , these four branch pairs can be analytically determined once the given values of n and Ω are specified.

2.3. Methods to determine the propagating mode pattern

As mentioned earlier, the solutions regarding the modal patterns (eigenvectors) for all four root branch pairs are important. The conventional method has been frequently used for a long time. In this method, the mode shapes are expressed as the ratios among U , V and W . By returning to Eq.(4) after each of the roots ($\pm s_i$, $i=1$ to 4) have been found for a given Ω , these ratios can be found by solving any two of the three simultaneous equations. Finally, the third can be discarded. Detail processes can be obtained from Leissa. Because the value of the ratio U/W or V/W can become quite large when either U or V is the predominant component of the mode, this method is not the most convenient and natural way to express the eigenvectors, particularly when eigenfunction expansion is used to solve vibration problems.

A new alternative method, which solves for the eigenvectors by using a commercially available linear algebra package, will be introduced. This method is extremely simple and straightforward. The kernel of processing is by using the built-in formulation of eigenvalue and eigenvector problem in the numerical package.

According to the eigenvalue problem, the eigenvectors can be found by solving the following homogeneous equations, and the simple flow can be introduced by following:

Step 1. For a specific frequency, dimensionless frequency, Ω , can be obtained and rewritten as Ω_s . In this way, eight dimensionless wavenumber, s^2 , can be also found easily from Eqs. (7), (10), or (12). Then the homogeneous equation by substituting any one of s^2 into Eq. (4) can be obtained as below:

$$\begin{bmatrix} L_{11}^*(s,n) - \Omega_s^2 & L_{12}^*(s,n) & L_{13}^*(s,n) \\ L_{12}^*(s,n) & L_{22}^*(s,n) - \Omega_s^2 & L_{23}^*(s,n) \\ L_{13}^*(s,n) & L_{23}^*(s,n) & L_{33}^*(s,n) - \Omega_s^2 \end{bmatrix} \begin{Bmatrix} U(s,n,\Omega) \\ V(s,n,\Omega) \\ W(s,n,\Omega) \end{Bmatrix} = \begin{Bmatrix} 0 \\ 0 \\ 0 \end{Bmatrix} \quad (13)$$

where the asterisk in superscript of L_{ij} represents that all the coefficients are known.

Step 2. After slightly rearranging, Eq.(13) can be further modified as

$$\begin{bmatrix} L_{11}^*(s,n) & L_{12}^*(s,n) & L_{13}^*(s,n) \\ L_{12}^*(s,n) & L_{22}^*(s,n) & L_{23}^*(s,n) \\ L_{13}^*(s,n) & L_{23}^*(s,n) & L_{33}^*(s,n) \end{bmatrix} \begin{Bmatrix} U(s,n,\Omega) \\ V(s,n,\Omega) \\ W(s,n,\Omega) \end{Bmatrix} = \Omega_s^2 \begin{Bmatrix} U(s,n,\Omega) \\ V(s,n,\Omega) \\ W(s,n,\Omega) \end{Bmatrix} \quad (14)$$

Step 3. If Ω_s^2 is assumed to be unknown for the time being, Eq.(14) can be rewritten to be a typical linear eigenvalue problem and shown as:

$$\begin{bmatrix} L_{11}^*(s,n) & L_{12}^*(s,n) & L_{13}^*(s,n) \\ L_{12}^*(s,n) & L_{22}^*(s,n) & L_{23}^*(s,n) \\ L_{13}^*(s,n) & L_{23}^*(s,n) & L_{33}^*(s,n) \end{bmatrix} \begin{Bmatrix} U(s,n,\Omega) \\ V(s,n,\Omega) \\ W(s,n,\Omega) \end{Bmatrix} = 0 \quad (15)$$

In most cases in Eq. (15), for any given value of s (the analytical root), there are three distinct eigenvalues in Ω^2 by using the built-in eigenvector function in the numerical package, but only one of them will be equal to Ω_s^2 . Consequently, the eigenvector solution of Eq.(13) is one of the three eigenvectors of Eq.(15), which corresponding eigenvalue is equal to Ω_s^2 . This is because, among the three eigenvalues, only the one that is equal to Ω_s will yield the specific s given here, the other two will yield different values of s and are not what we want. When s is specified, the corresponding eigenvector can further be calculated by using the numerical solution package, such as MatLab.

2.4. Comparison between alternative and conventional method for modal pattern

The dispersion relations were calculated using the thickness-radius factor $\beta=0.0058$ and the Poisson ratio $\nu=0.3$. For $n=2$, the dispersion relation and corresponding modal patterns of Branch pairs 1 are obtained in Fig. 2.(a) and 2(b). The consistency of modal patterns between the alternative and conventional method can also be demonstrated in Fig. 2.(c). The physical

characteristics and variations of cylindrical shell at specific circumferential number can be obtained clearly and straightforward.

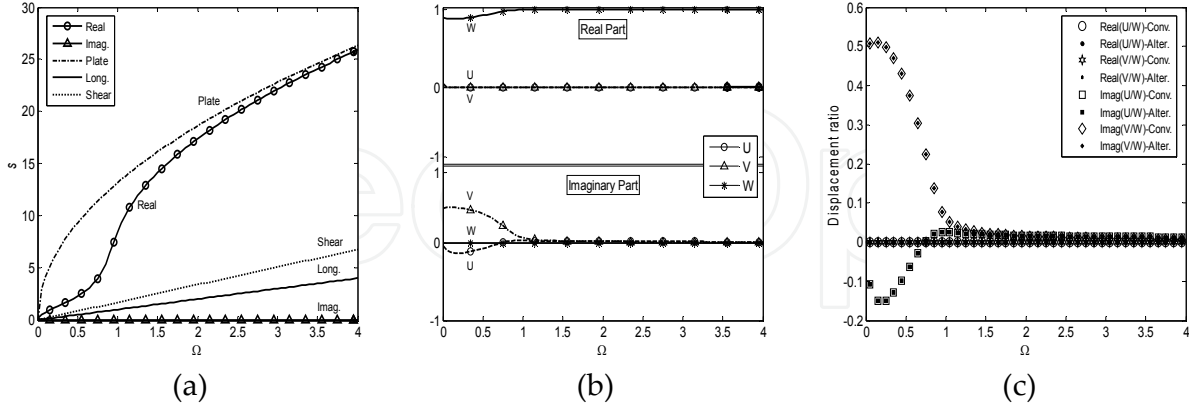

Figure 2. (a) The dispersion curve for Branch 1 roots; (b) The eigenvectors obtained from the current method expressed as $[U \ V \ W]^T$; (c) Comparison between the eigenvectors (of Branch 1 roots) obtained from the conventional and the current methods ($n=2$).

3. Result and discussion

In order to discuss the characteristics of wave propagation in dispersion relations and modal pattern, the numerical results are calculated by assuming the dimensionless thickness parameter, β , to be equal to 0.0058, and the Poisson ratio equals to 0.3. According to Karczuzb and Leissa, for the usual range of parameters and $n \geq 1$, the roots of Eq.(11) were found to have the four following types:

$$\begin{aligned}
 \text{TYPE-1: } & s = \pm(b_1) \\
 \text{TYPE-2: } & s = \pm(ib_2) \\
 \text{TYPE-3: } & s = \pm(c + id) \\
 \text{TYPE-4: } & s = \pm(c - id)
 \end{aligned} \tag{16}$$

where b_1 , b_2 , c and d are positive real numbers. The propagating wave of cylindrical shell is dedicated only by Type 1. Type 2 root constitutes no spatially oscillating term, which represents the nearfield distortion close to the boundary. Type 3 and Type 4 roots represent various types of evanescence waves. However, these four types of roots, do not have a one-to-one correspondence with the four branch pairs shown in Eq.(12). For example, in the case of $n=2$, the curve of Branch pair 1 begins as a Type 3 (evanescence waves) and then gradually turns into Type 1 (propagating waves) after crossing its cut-off frequency. When $n=0$ or $n=1$, the curves of branch pair 1 are Type 1 roots (do not have a cut-off frequency), and they remain as Type 1 roots for all frequencies.

The dispersion curves for all the roots and the corresponding eigenvectors plotted in the figures shown hereafter are those with positive real parts only. In the case of Type 2 roots which have no real part, only the positive imaginary part will be plotted. The roots with

negative real parts are not plotted; their eigenvectors are basically the same as those of positive real roots, except there will be sign changes in the longitudinal components if the signs of the radial and circumferential components are chosen to be the same as those plotted.

3.1. The case when $n=0$

The dispersion relations and the associated eigenvectors are shown in Fig. 3 and 4, respectively. For simplicity, the eigenvectors $[U' V' W']$ are plotted by using the absolute values of the displacement components, i.e., $[|U| |V| |W|]$. The dispersion relations for the longitudinal and bending waves of a plate, and those for shear waves are also shown for reference. It shows that at frequencies much lower than the ring frequency ($\Omega \ll 1$), Branch 1 represents a non-dispersive longitudinal wave, from which it gradually deviates as Ω approaches the neighborhood of unity; Branch 1's wave eventually approaches that of a plate bending wave when $\Omega \gg 1$. These are illustrated by the mode shapes shown in Fig. 4(a). Below ring frequency, see the mode shape in Fig. 4(b), Branch 2 (Branch pair 2 root with positive real part) represents the Type 4 root, but it becomes a Type 1 root after crossing the ring frequency and represents the longitudinal wave above the ring frequency, say $\Omega > 1$. Therefore, when $\Omega > 1$, the Branch 2 curve takes over the role of representing the longitudinal wave which was previously the role of Branch 1's curve. Below the ring frequency, Branch 3 (Branch pair 3 root with positive real part) represents the Type 3 root, but above the ring frequency, it represents the Type 2 root. The modal components of the Branch 3 roots are predominantly radial (see Fig. 4(c)). Branch 4 (Branch pair 4 root with positive real part) represents the characteristic roots of Eq. (13), which therefore represents the non-dispersive torsional wave and has nearly the same dispersion relation as shear waves. The mode shape of torsional mode is not shown; it is simply $[U V W]' = [0 \ 1 \ 0]'$.

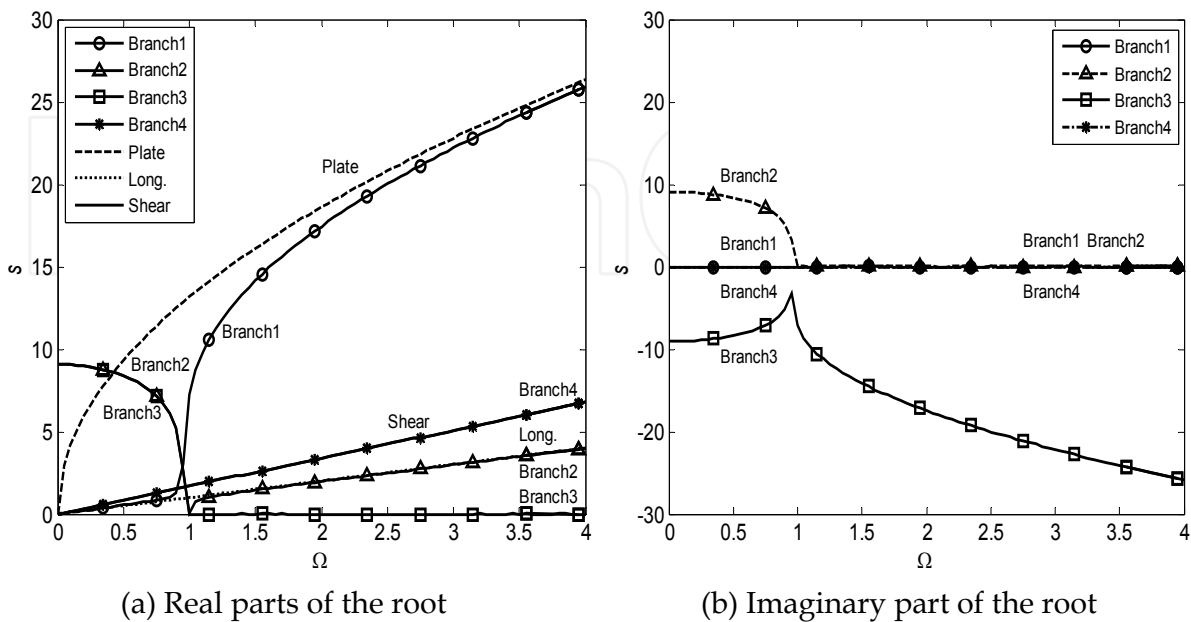

Figure 3. The dispersion relations for $n=0$ circular harmonic

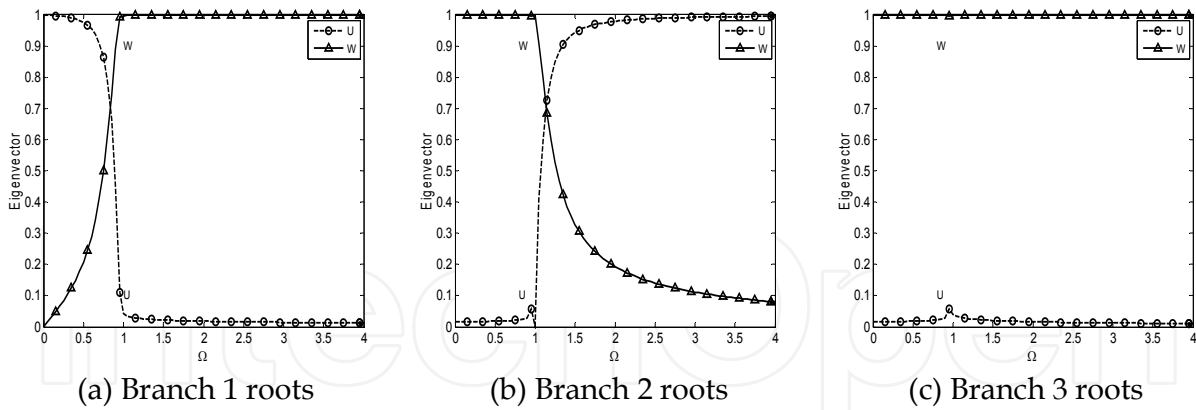

Figure 4. The normalized eigenvectors of $n=0$ circular harmonic (no V component)

3.2. The case when $n=1$

Fig. 5 and 6 show the dispersion relations and the associated eigenvectors, respectively, for the $n=1$ circular harmonics. The equivalent curves for Bernoulli beam (labeled as “Berbeam”), Timoshenko beam (labeled as “Timbeam”), and the longitudinal and shear wave curves of a plate are also shown for reference. Branch 1 has only real roots (Type 1 roots); the dispersion curve representing beam bending (when $\Omega < 0.5$) agrees well with that of the Timoshenko beam. The Bernoulli beam, on the other hand, agrees with the shell and Timoshenko beam curves only up to $\Omega = 0.03$; its applicable frequency range is therefore limited. At frequencies above $\Omega = 0.5$, the originally beam-like bending wave gradually transitions to a plate-like bending wave with a predominantly radial modal displacement.

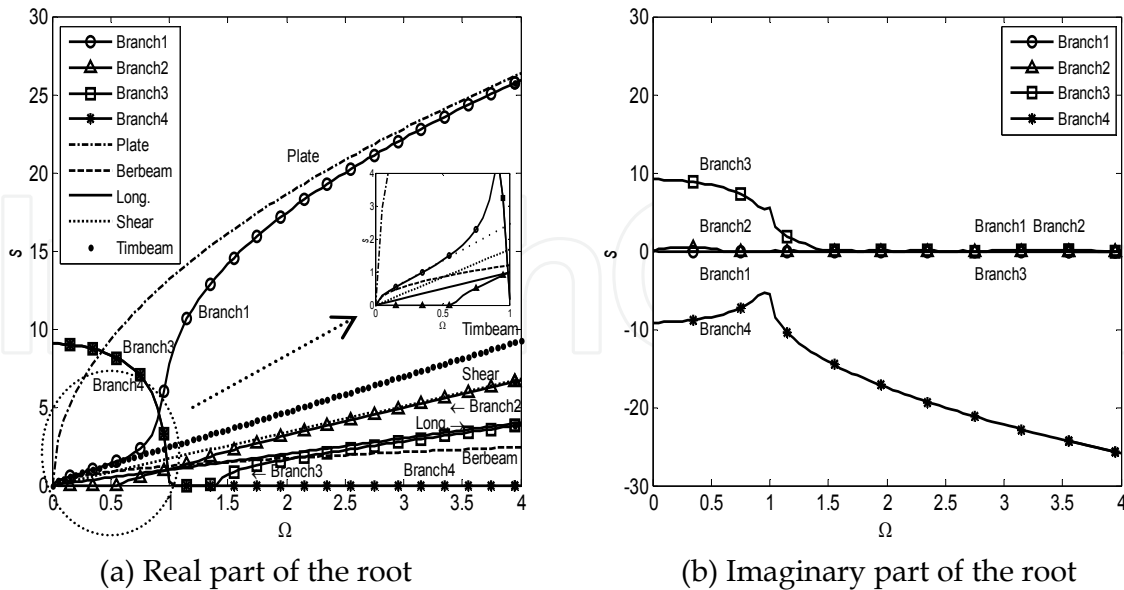

Figure 5. The dispersion relations for $n=1$ circular harmonic

Below $\Omega = 0.5$, the Branch 2 curve is purely imaginary, and represents the Type 2 root. When $\Omega > 0.5$, the roots become positive real (Type 1) and gradually approach the shear wave

curve, with a predominantly circumferential displacement component when $\Omega > 1.5$ (see Fig. 6(b)). Obviously, this branch has a cut off frequency which is about $\Omega = 0.5$.

Below the ring frequency, the Branch 3 curve indicates a Type 3 root with a slow and exponentially diminishing wave. When $\Omega > 1.4$ it becomes a Type 1 root, and the Branch 3 curve approaches that of longitudinal wave (see Fig. 5 and 6(c)) at further higher frequencies. The propagating waves in Branch 3 thus has a cutoff frequency of about $\Omega = 1.4$. The Branch 4 curve indicates a Type 4 root below the ring frequency, but above ring frequency it has only the imaginary part (Type 2) and represents the transversal near field distortion (see Fig. 6(d)).

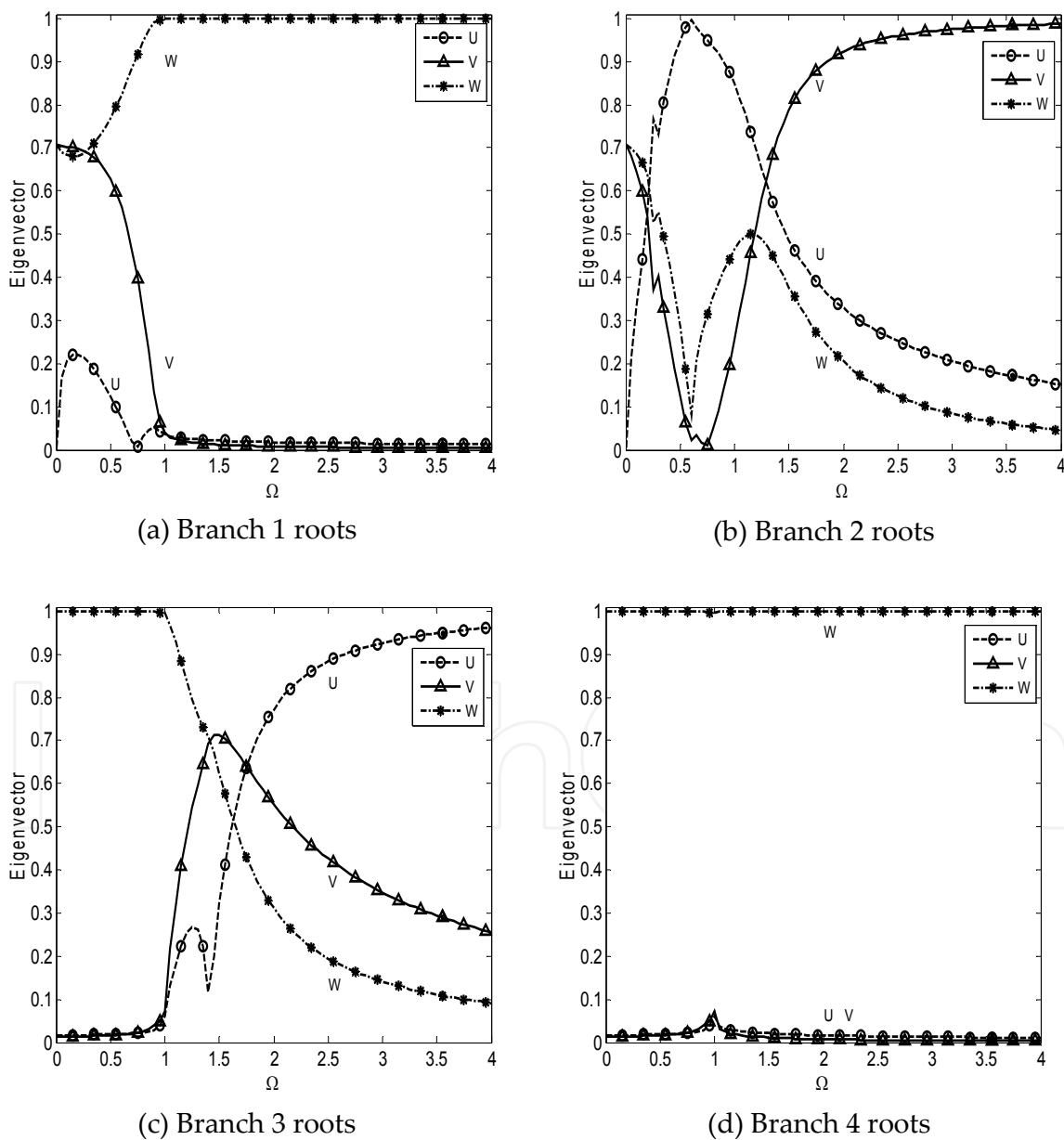

Figure 6. The normalized eigenvectors of $n=1$ circular harmonic.

3.3. The case when $n=2$

The dispersion relations for the $n=2$ circular harmonic case are shown in Fig. 7. At very low frequencies, say $\Omega < 0.016$, the roots in Branch 1 are the Type 3 roots. At higher frequencies, the roots become Type 1 and represent propagating waves (which thus have a cut off frequency at $\Omega = 0.016$). Fig. 8(a) shows that below ring frequency, $\Omega < 1$, the modal patterns of Branch 1 roots have three well-coupled displacement components, although the predominant component is radial. When $\Omega > 1$, the modal displacement becomes predominantly radial and the propagating speed asymptotically approaches that of a plate.

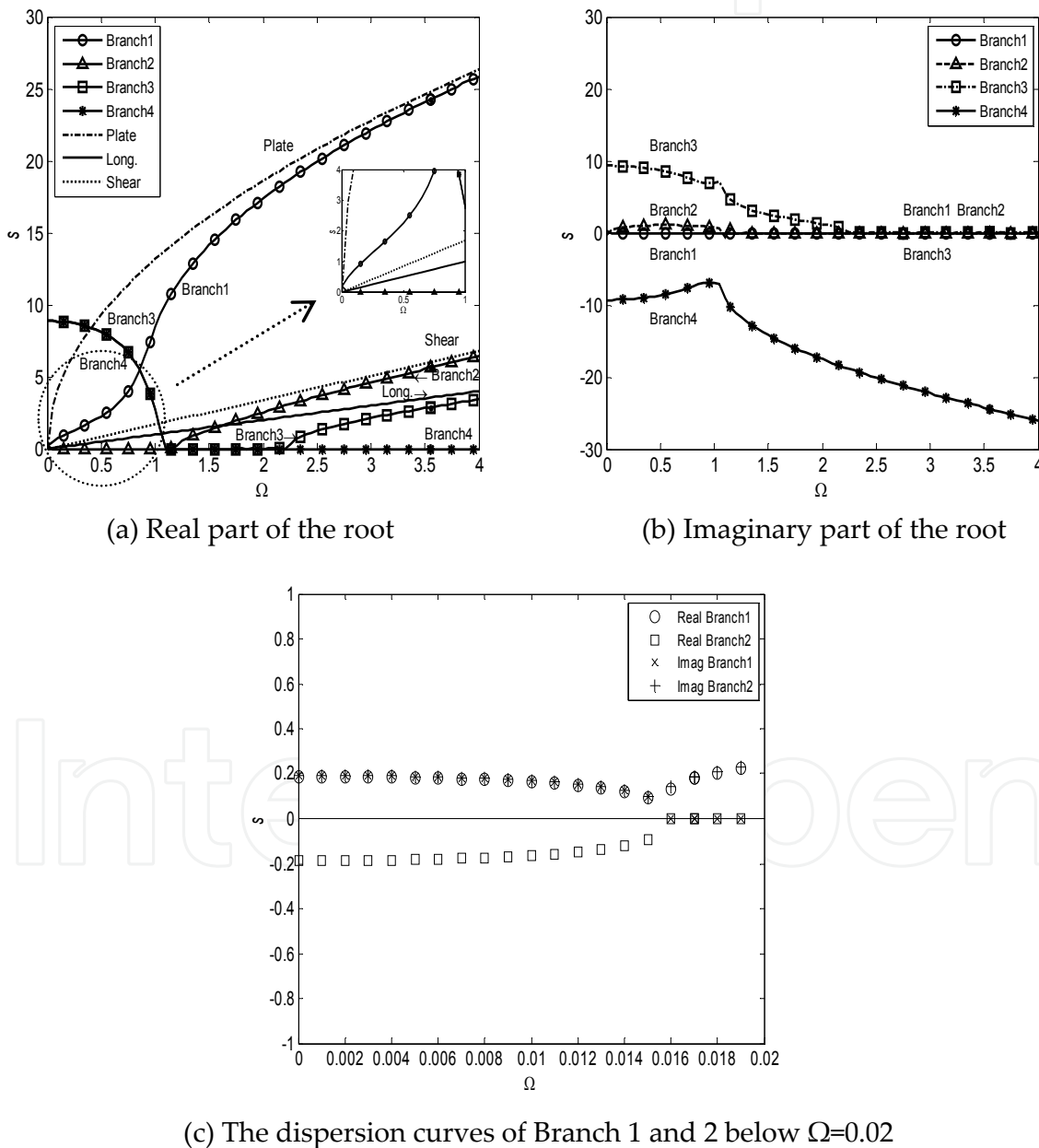

Figure 7. The dispersion relations for $n=2$ circular harmonic

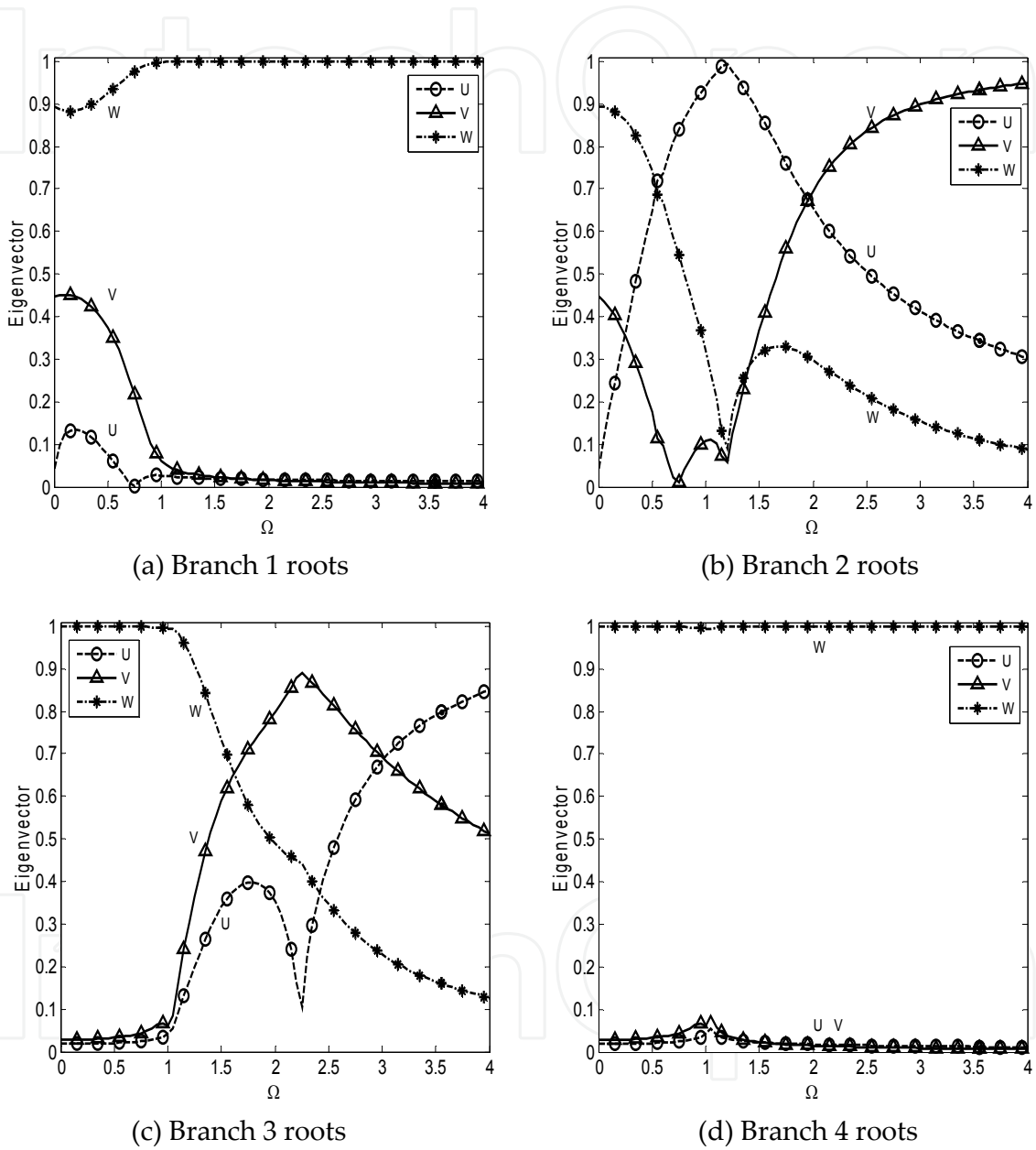

Figure 8. The normalized eigenvectors of $n=2$ circular harmonic

At very low frequencies, say $\Omega < 0.016$, the roots in Branch 2 are the Type 4 roots. Between say $\Omega = 0.016$ and the ring frequency, the roots of this branch are Type 2; they represent the near field distortion of the three coupled components. When $\Omega > 1.15$, they become Type 1 propagating waves with the wave speeds that asymptotically approach that of the shear wave, and their modal patterns reflect predominantly circumferential shear motions. The curve of Branch 3 indicates a Type 3 root when $0 < \Omega < 1.15$, a Type 2 root when $1.15 < \Omega < 2.2$, and a Type 1 root when $\Omega > 2.2$. This is a propagating wave with a high cutoff frequency (at $\Omega = 2.2$), and at higher frequencies its wave speed approaches asymptotically to that of the longitudinal wave. Branch 4 represents the Type 4 root when $0 < \Omega \leq 1.15$, which, however, turns into Type 2 and represents the near field distortion when $\Omega > 1.15$.

4. Conclusion

The classic problem of the dispersion of waves in a cylindrical shell had been re-examined with analytical solutions obtained by using a symbolic algebra package. The previous work by Karczuzb did not include the analytical solutions for the dispersion relations of axisymmetric waves (of circular harmonic order $n=0$). An axisymmetric wave contains both longitudinal and transverse components; the former are important in the transmission of longitudinal vibration, and the latter are particularly important in acoustics due to their higher acoustic radiation efficiency than the corresponding waves of higher circular harmonic orders ($n > 0$). In this way, a complete set of analytical solutions which based on Flügge shell theory is now available for all orders of circular harmonics, $n=0, 1, 2, \dots, \infty$.

A considerable effort has been expended on the solutions for the modal patterns of all propagating and non-propagating modes, because a complete set of properly normalized eigenvectors is crucial to the solution of the vibration problem of a finite shell under various admissible boundary conditions. The eigenvectors obtained by the conventional method are not conveniently normalized as are those commonly used in mathematical physics. A new alternative method to find normalized eigenvectors with norms equal to unity has been proposed and discussed.

Use of analytical solutions has demonstrated the capability of a straightforward continuous tracking on the frequency-dependent changes of the root types and of the corresponding modal patterns for each branch of the dispersion curves associated with a particular analytical root. Therefore, a parallel display of the dispersion curves and of the associated modal patterns used in this paper has provided more insight about the wave phenomena in a cylindrical shell.

Appendix

The coefficients in Eq. (11) are listed as follows:

$$\begin{aligned}
g_0 = & n^2 \beta^2 v_1 (1 + \beta^2) \{-n^2 + 2n^3 - n^4\} \\
& + \Omega^2 n^2 \left\{ \left[\beta^4 v_1 + 2\beta^2 v_2 + v_1 \right] + n^2 \left[-2\beta^4 v_1 - \beta^2 (4v_2 - 3v_1) + v_1 \right] \right. \\
& \left. + n^3 \beta^2 \left[\beta^2 v_1 + (2v_2 - v_1) \right] \right\} \\
& + \Omega^4 \left\{ \left[1 + \beta^2 \right] + n^2 \left[\beta^2 (v_3 - 2v_4) + (v_1 - 2v_2) \right] + n^4 \beta^2 \right\} - \Omega^6
\end{aligned} \tag{A.1}$$

$$\begin{aligned}
g_2 = & n^2 \beta^2 v_1 \left\{ \left[3\beta^4 v_1 + 7\beta^2 v_1 + 2(v - 2) \right] - 2n^2 \left[3\beta^4 v_1 + \beta^2 (3v_1 + 2v_2) + (v - 4) \right] \right. \\
& \left. + n^3 \left[3\beta^4 v_1 - \beta^2 (v_1 - 4v_2) - 4 \right] \right\} \\
& + \Omega^2 \left\{ \left[3\beta^4 v_1 + \beta^2 (2v - 3) + (v^2 - v_1 + 2v_2) \right] \right. \\
& \left. + n^2 \beta^2 \left[3\beta^2 v_1 (v_3 - 2v_4) + 2(3v_1 - 4v_2) + 2v_1 \right] \right. \\
& \left. + n^4 \left[\beta^2 v_1 (-7v_3 + 8v_4) + 3(2v_2 - v_1) \right] \right\} \\
& + \Omega^4 \left\{ \left[-3\beta^2 v_1 + (v_1 - 2v_2) \right] + 2n^2 \beta^2 \right\}
\end{aligned} \tag{A.2}$$

$$\begin{aligned}
g_4 = & \left\{ v_1 \left[-3\beta^4 + \beta^2 (-4 + 3v^2) + 2v_1 v_3 \right] + 3n^2 \beta^2 \left[-\beta^2 (2v_1 (-2 + v^2) + v_2) + 2v_1 \right] \right. \\
& \left. + n^4 \beta^2 v_1 \left[\beta^4 v^2 + 6\beta^2 v_2 - 6 \right] \right\} \\
& + \Omega^2 \beta^2 \left\{ \left[(11v_1 - 4v_2) + v_1 \right] + n^2 \left[\beta^2 (1 + 7v_1 + v_1^2) + 3(2v_2 - v_1) \right] \right\} \\
& + \Omega^4 \beta^2
\end{aligned} \tag{A.3}$$

$$\begin{aligned}
g_6 = & \beta^2 v_1 \left\{ \left[2v (1 + 3\beta^2) \right] + n^2 \left[9\beta^4 v_1 + \beta^2 (8v_2 - 5v_1) - 4 \right] \right\} \\
& + \Omega \beta^{22} \left\{ v_1 (-1 + 5\beta^2) + 2v_2 (-1 + \beta^2) \right\}
\end{aligned} \tag{A.4}$$

$$g_8 = \left\{ \beta^2 v_1 \left[3\beta^4 - 2\beta^2 - 1 \right] \right\} \tag{A.5}$$

where

$$\begin{aligned}
v_1 = \frac{-1 + v}{2}, & & v_2 = \frac{-2 + v}{2} \\
v_3 = \frac{1 + v}{2}, & & v_4 = \frac{2 + v}{2}
\end{aligned} \tag{A.6}$$

The coefficients in Eq. (12) are given in the following.

$$\begin{aligned} A_1 &= \left(\sqrt{\Lambda_1 + \Lambda_2} \right) / 2, & A_2 &= -\Lambda_1 / 4 \\ A_3 &= \left(\sqrt{\Lambda_5 - \Lambda_6} \right) / 2, & A_4 &= \left(\sqrt{\Lambda_5 + \Lambda_6} \right) / 2 \end{aligned} \quad (\text{A.7})$$

where

$$\begin{aligned} \Lambda_1 &= 2^{1/3} \lambda_4 / (3g_8 \lambda_7^{1/3}) + \lambda_7^{1/3} / (3g_8 2^{1/3}), & \Lambda_2 &= (\lambda_1^2 / 4) - (2\lambda_2 / 3), \\ \Lambda_3 &= (\lambda_1^2 / 2) - (4\lambda_2 / 3), & \Lambda_4 &= -\lambda_1^3 + 4\lambda_6 - 8\lambda_3, \\ \Lambda_5 &= -\Lambda_1 + \Lambda_3, & \Lambda_6 &= \Lambda_4 / (4\sqrt{\Lambda_1 + \Lambda_2}) \end{aligned} \quad (\text{A.8})$$

and

$$\begin{aligned} \lambda_1 &= g_6 / g_8, & \lambda_2 &= g_4 / g_8, & \lambda_3 &= g_2 / g_8, & \lambda_4 &= g_4^2 - 3g_2g_6 + 12g_0g_8, \\ \lambda_5 &= 2g_4(g_4 - 4g_2g_6 - 36g_0g_8) + 27(g_0g_6^2 + g_8g_2^2), & & & & & \\ \lambda_6 &= g_4g_6 / g_8^2, & \lambda_7 &= \lambda_5 + \sqrt{-4\lambda_4^3 + \lambda_5^2} \end{aligned} \quad (\text{A.9})$$

Author details

Yu-Cheng Liu, Yun-Fan Hwang and Jin-Huang Huang
Feng Chia University, Electroacoustic Graduate Program, Taiwan, R.O.C.

5. References

- [1] Forsberg K. (1963). Influence of boundary conditions on the modal characteristics of thin cylindrical shells. *Journal of the Acoustical Society of America*, Vol.119, No.6 , pp. 1898-1899, ISSN 1729-8806.
- [2] Fuller C. R. (1981). The effects of wall discontinuities on the propagation of flexural waves in cylindrical shells. *Journal of Sound and Vibration*, Vol.75, pp. 207-228, ISSN 0022-460X.
- [3] Hwang Y. F. (2002). Structural-acoustic wave transmission and reflection in a hose- pipe system, Proceedings of 2002 ASME International Mechanical Engineering Congress and Exposition, IMECE2002-32683, pp. 91-96, , ISBN 0791836436.
- [4] Karczub D. G. (2006). Expressions for direct evaluation of wave number in cylindrical shell vibration studies using the Flügge equations of motion. *Journal of the Acoustical Society of America*, Vol.119, No.6, pp. 3553-3557, ISSN 0001-4966.
- [5] Lesmez M. W., Wiggert D. C., and Hatfield F. J. (1990). Modal analysis of vibrations in liquid-filled piping systems. *Journal of Fluids Engineering ASME*, Vol. 112, No. 3, pp. 311-318, ISSN 0098-2202.
- [6] Leissa A. W. (1997). *Vibration of Shells*, Acoustical Society of America, ISBN 1563962934.

- [7] Skelton E. A. & James J. H. (1997). *Theoretical Acoustics of Underwater Structures*, Imperial College Press, ISBN 1860940854.
- [8] Liu Y. C., Hwang Y. F., and Huang J. H. (2009). Modes of wave propagation and dispersion relations in a cylindrical shell. *ASME Journal of Vibration and Acoustic*, Vol. 131, No. 4, 041011-1~9, ISSN 1048-9002.

IntechOpen

IntechOpen