

# We are IntechOpen, the world's leading publisher of Open Access books Built by scientists, for scientists

**4,800**

Open access books available

**122,000**

International authors and editors

**135M**

Downloads

Our authors are among the

**154**

Countries delivered to

**TOP 1%**

most cited scientists

**12.2%**

Contributors from top 500 universities



**WEB OF SCIENCE™**

Selection of our books indexed in the Book Citation Index  
in Web of Science™ Core Collection (BKCI)

Interested in publishing with us?  
Contact [book.department@intechopen.com](mailto:book.department@intechopen.com)

Numbers displayed above are based on latest data collected.

For more information visit [www.intechopen.com](http://www.intechopen.com)



---

# Increasing the Energy Efficiency in Compressed Air Systems

---

Dragan Šešlija, Ivana Ignjatović and Slobodan Dudić

Additional information is available at the end of the chapter

<http://dx.doi.org/10.5772/47873>

---

## 1. Introduction

The increase of energy efficiency is a general trend in a worldwide relation. According to the Kyoto Protocol from 1997, the EU has to reduce greenhouse gas emission by 8% below the level from 1990 by the 2008 - 2012 period. To achieve these reductions, substantial efforts have to be undertaken in all branches of human enterprise.

One of the important industry utilities that has to be encompassed by this energy policy are compressed air systems (CASs). The application of compressed air has had a growing trend due to its easy and safe generation, manipulation, and usage. In previous years, the research efforts in this domain were concentrated on the CASs development and application aimed at boosting the productivity regardless of the energy consumption. With increased awareness of the energy costs as well as the effects of greenhouse gas emission, the attention has been recently placed on the energy efficient use of compressed air.

The experience gained in numerous CAS optimisation projects, as well as the opinions of the experts in the field, indicated that many industrial systems are missing the chance to improve energy savings with the relatively low costs of projects for increasing energy efficiency. Energy saving measures in CASs that have been identified in the course of energy audits in the small and medium industrial enterprises may yield an average energy saving of nearly 15%, with a payback of two years, the energy saving potential in some of them amounting from 30% up to even 60% (USDOE, 2001). The basis for all decisions concerning energy efficiency of the existing CASs is the understanding of the way of their functioning and existence of appropriate data. In that sense, it would be necessary to make measurements of consumed electricity of compressors, airflow, system leakage and pressure drop in the system.

Besides energy savings, increasing energy efficiency of CASs may ensure other significant benefits for the enterprise. Energy saving measures imply a high monitoring level of CASs and

appropriate maintenance. That leads to decreased breakdowns of production equipment, avoiding the loss of raw materials or other inputs, longer life cycle of pneumatic devices and higher reliability of CASs. Reduction in energy consumption will also lower the emissions of dangerous and polluting substances, which will lessen the influence on the environment. Often, these benefits are more valuable than the energy savings.

This paper is concerned with the identification of the current state of energy efficiency in the production and usage of compressed air and possibilities for improvements that would yield the corresponding energy saving.

## **2. Current state of energy efficiency of compressed air systems**

It is often present a misconception that the costs of compressed air are so low that they do not justify the expenditure of expensive managerial time for optimising all the parameters included in this problem. However, the air is free of charge only before compression. But, after the compression, it has significant price so it is justified to invest efforts in increasing energy efficiency of CAS. Firstly, it is necessary to identify the current state of CAS from the aspect of energy efficiency. In that sense, a brief outline of the state of CASs in the USA, European Union, China, and Serbia were given. The USA was taken because of its leading position in the industry; European Union because of its overall significance; China as an example of the fast-growing industry, and Serbia as a typical example of a small, developing country.

### **2.1. State of energy efficiency in USA**

A key finding of a survey carried out within the "Motor Challenge Program" (MCP), launched in 1993, was that 20% of all US electricity was used to operate industrial motor-driven systems, a large portion of this being associated with pumps, fans and blowers, and air compressor systems. The reported potential savings were over 1 TWh of electricity or USD 3 billion per year, with the existing and new technology by 2010 (or 10% of the total energy cost of industrial motor-driven systems). System improvement opportunities were recognized in motor sizing and proper matching to load, improvements in the system layout, updating and well-maintaining controls, improving operation and maintenance, and use of adjustable speed drives (McKane et al., 1997).

The MCP was followed by the project "Compressed Air Challenge" of the US Department of Energy (USDOE, 2001). One of the most significant findings of this project was that the CASs energy consumption in a typical manufacturing facility could be reduced by 17% through appropriate measures, with a payback of 3 years or less. Apart from these energy savings, improvements to the energy efficiency of CASs could also yield some other important benefits to the end users, such as reliable production, less rejects, higher quality, etc.

### **2.2. State of energy efficiency in European Union**

The European Commission launched the "Motor Challenge Program" with the aim to overcome energy efficiency barriers. Of the total electricity consumption in the EU-15 in

2000, of the overall 2,574 billion kWh, 951 billion kWh were used in the industry. Of this, 614 billion kWh, or 65%, was consumed by motor-driven systems. It was estimated that the potential saving could be 181 billion kWh, (29%), or seven percent of the overall electricity consumption (De Keulenaer et al., 2004).

According to the study “Compressed Air Systems in European Union” (Radgen and Blaustein, 2001), the EU-15 was spending 10% of the total electricity consumed in the industry for the production of compressed air. The most important potential energy savings are related to the system installation and renewal (the overall system design, improvement of drives, use of sophisticated control systems, recovering heat waste, improved cooling, drying and filtering, reducing frictional pressure losses, etc.) and system operation and maintenance (reducing air leaks, more frequent filter replacement, etc.). The percentages of potential saving varied from country to country. For instance, Germany spent seven percent, United Kingdom 10%, Italy, France and the rest of EU 11% (Radgen and Blaustein, 2001). Details on potential energy savings can be found in the corresponding references: for Germany in (Radgen, 2003; Radgen, 2004), for Switzerland in (Gloor, 2000), for Sweden in (Henning, 2005), and for Austria in (Kulterer and Weberstorfer, 2007).

### **2.3. State of energy efficiency in China**

The electricity consumption of CASs in Chinese enterprises goes from 10% up to 40% (Li et al., 2008) of the total industrial electricity consumed. According to (Li et al., 2008), the most widely used compressors in China are reciprocating compressors, often several decades old. To meet increased compressed air demands, many enterprises have undertaken retrofits of their CASs, yielding increased compressor capacity, improved system piping, etc. The most frequently implemented energy saving measures are: purchasing rotary screw compressors, application of variable speed drives and changes to the piping system to allow centralized production of compressed air, etc.

### **2.4. State of energy efficiency in Serbia**

Based on data of the Electric Power Industry of Serbia (EPS, 2009a), the amount of electricity consumed in Serbia in 2008 was 27,639 GWh. Industrial CASs installed in Serbia consume about 8% of the electricity used by industry (Šešlija et al., 2011). Although this percentage is low compared to the values reported for some other countries (Radgen and Blaustein, 2001; Radgen, 2003; Radgen, 2004), this does not mean that the CASs in Serbia are more efficient. This low consumption percentage is a consequence of the inefficient electricity utilization in the industry, the value of energy intensity being three times higher than in the developed European countries (USEIA, 2006). Besides, the price of electricity in Serbia is relatively low, and it does not exist appropriate attention to its economic utilization.

There is a high potential for increasing energy efficiency of CASs in Serbia. One of possible ways of increasing the energy efficiency of CASs is the replacement of the reciprocating single-acting compressors with rotary screw compressors, which would reduce the CAS

energy consumption by about 2.8%. On the other hand, the introduction of frequency regulation would result in the saving of 10% (Wissink, 2007). If this is combined with the potential saving that could be achieved by eliminating air leak in CASs, which is in average 30%, and if this mode of saving is applicable in about 80% of companies (Radgen and Blaustein, 2001), the additional reduction would be 24%. This would result in the potential saving of 36.8% of the total energy consumed by CASs. With the current price, which is regulated by the government, of approximately 0.04 €/kWh (EPS, 2009b), Serbia could save at least € 8.07 million every year.

Energy saving measures should be applied in all developing countries, also as in developed countries, because the process for increasing energy efficiency is continuous and never ending.

### 3. The possibilities for the energy efficiency increase in the CAS

The establishment of measures for efficient production, preparation and distribution and rational consumption of compressed air is important in order to increase the energy efficiency. By applying the procedures for pneumatic system optimisation, rational consumption, compressed air preparation and appropriate equipment selection, with skilled management and software support, and proper maintenance, it is possible to significantly improve the energy efficiency of CAS. Production and distribution of compressed air is one of the most expensive and least-understood processes in a manufacturing facility. The costs of compressed air are often unknown or hidden within other operation costs.

In the majority of plants only a portion of total produced compressed air is used in an efficient manner. The system's operation depends on characteristics of each element but even more on the design of the entire system. Identification of possibilities for increasing energy efficiency in compressed air systems are very important step in overall optimisation procedure (Šešlija et al., 2009). The following technical measures can improve the functioning of the entire process of a compressed air system with the return of investment of less than 3 years:

- Power drive improvement: usage of high efficiency drives and integration of variable speed drives,
- Optimal choice of compressor type, as a function of specific needs of end users,
- Improvement in compressor technology, particularly in the segment of multistage compressors,
- Application of sophisticated control systems, for compressed air production,
- Regeneration of the dissipated heat and using it in other functions,
- Improvement of compressed air preparation: reduction of pressure and energy lost in processes of cooling, drying and filtering; optimisation of filtering and drying as a function of consumer needs and temperature conditions,
- Overall system design, including the systems with multiple pressure levels,
- Reduction of pressure losses due to friction in the pipeline,
- Air leakage elimination,
- Reduction of operation pressure,

- Optimisation of devices that consume compressed air: application of more efficient, better adjusted devices or, in some cases, replacement of compressed air with an electrical drive,
- Optimising the control systems at the point of use,
- Measuring and recording of the system performance.

### **3.1. Power drive improvement**

Usage of high efficiency drives increases the energy efficiency. Integration of variable speed drives (VSD) into compressors can lead to energy efficiency improvements with respect to characteristics of the load. Application of high efficiency drives renders the largest savings to new systems, because the chances of users installing high efficiency drives into existing compressor systems, without changing the compressor itself, are rather small. Integration of speed controllers (frequency inverters) into compressed air systems is a very cost effective measure, under the conditions of variable demands, and it is estimated that such systems participate in the industry with 25%. In compressor rooms where several compressors are installed, variable speed drives are integrated into only one machine and are usually coupled with more sophisticated control system for the whole compressor station that powers on and off individual compressors with a constant speed and also varies the speed of one compressor in order to adjust the production of compressed air to instantaneous requirements of consumers.

### **3.2. The optimal selection of compressor type**

The segment of the market covering power range from 10 to 300 kW is now dominated by rotary screw compressors with oil injection – it is estimated that around 75% of compressors sold in EU belong to this category (Radgen and Blaustein, 2001). Besides, there are other compressor types available that have other advantages within certain exploitation characteristics. In order to make an optimal selection of compressor it is necessary to consider the users' demands. The choice of compressor can greatly influence the energy efficiency of the system, with respect to compressor performance, but also regarding multiple interactions with other elements in the system. The advantages of multiple compressor systems are especially emphasized in production systems with the high workload that operates almost continuously.

### **3.3. Improvements in compressor technology**

A whole array of efforts is directed towards improving the existing compressor lines but also the development of new types, which are usually customized to different segments of industry. Another aspect of research is concerned with improving production methods such as applying narrower tolerances in order to reduce the leakage within the compressor.

It must be taken into consideration that the laws of thermodynamics limit the further improvements of compressor so that only minor improvements can be made in the area of energy efficiency, while the greatest potentials lie in adequate design of the entire system and procedures for system control and maintenance.



### 3.4. Application of sophisticated control systems for compressed air production

Sophisticated control systems are applied in order to adjust the compressor outlet flow to the requirements of the consumers. They save the energy by optimising the transition between non-loaded working state, loaded working state, and non-operating state of compressor. Sequencers optimise the operation of multiple compressor system and can be combined with applications of variable speed drives. Predictive control uses fuzzy logic and other algorithms to predict the future behaviour of consumers, assuming history of system behaviour. Since the price of control technologies is decreasing and industrial familiarity with its usage is simultaneously increasing, their usage is rapidly expanding and their applications on compressors are rising in the occurrence. This kind of control can be purchased along with new machines but can also be applied onto existing systems.

### 3.5. Regeneration of dissipated heat

Compressors intrinsically generate heat, which might be used for other functions. The recommendations for its usage depend on the presence of those consumers of thermal energy whose characteristics comply with the amounts of generated heat, whose usage is enabled by adequate equipment (heat exchangers, pipelines, regulators etc.). The price of that equipment should be favourable in comparison with alternative solutions. The design of the heat regeneration system must provide appropriate compressor cooling.

The heat dissipated by the compressor is in most cases too low in temperature, or too limited by its quality to adequately respond to the needs of industry regarding their main processes or heating. The climate and seasonal changes also influence the ratio between investments and yields. Typical application is heating the space close to the location of compressor, when needed. Possibilities for using the compressor recycled energy are:

- Use in buildings (water heating and building heating),
- Compressed air preparation (integral dryers with compressor, standard dryer regeneration),
- In processes (heating, drying),
- Boiler preheating (drinking water, boilers).

The cost efficiency of heat regeneration depends on available alternative energy sources. It could be very cost effective, only if it is alternative to electrical energy. However, if natural gas is available, or the process residual heat, the cost efficiency of regenerated heat is much smaller. However, the attention should be placed on renewable energy sources, instead of using fossil fuels.

### 3.6. Improvements in preparation of compressed air

Well prepared compressed air has the following purposes:

- *Prevents damaging of the production equipment.* The impurities contained in compressed air can cause malfunction of production equipment that uses it. The appropriate quality of compressed air increases the reliability of equipment that uses it.

- *Increases product quality.* In some production systems, compressed air enters the end product directly or comes into contact with the end product (for example in food and pharmaceutical industries or electronics). In these cases, poor compressed air quality leads to decrease in the end product quality.

The equipment for drying and filtering causes the pressure to drop while dryers often consume electrical energy or partially use compressed air for their operation and regeneration. Because of that, the optimisation of compressed air preparation as a function of the user needs is one of the main sources of energy savings. The possible measures are:

- The dynamical setting of the degree of drying in accordance with external temperature conditions. This is applicable only when the purpose of drying is to keep the air temperature above the dew point in order to prevent the condensation. This measure can be inappropriate if drying is required to fulfil the precisely defined needs of a process with respect to compressed air quality.
- To optimise the degree of particle filtering as well as oil and oil vapour filtering, so it can precisely match the needs of the system. Excessive filtering leads to unnecessary waste of energy. This problem is explained in detail in chapter 3.6.1.
- Increase the filter capacity. The increase of the number of filters in parallel operation decreases the speed of air and thus reduces pressure loss. This investment can be very cost effective for new as well as for existing systems.

### 3.6.1. Optimisation of filtering process

In order to optimise the filtering process it is necessary to (Golubović et al., 2007; Mitrović et al., 2006; Šešlija, 2002a; Šešlija, 2002b; Šešlija et al., 2008):

- Identify the possible filter locations,
- Define the flows, pressures, temperatures, allowed pressure drops, compatibility and needs for validation in critical places,
- Define the types and concentrations of contaminants (particles, water, oil, oil vapours, etc.),
- Determine the needed filtration stages for each characteristic location,
- Choose the adequate filter elements for each location,
- Choose the housings for each characteristic location.

Every aspect of the previous algorithm deserves special attention. When the selection of filter elements is in question, they are generally expected to have a high throughput, large filtration surface, high mechanical resilience, high thermal resistance, high contamination capacity, long operation period between the services, low price and low exploitation costs as well as appropriate certification, the possibility to fulfil quotas, standards and legislature requirements in their area of application. Proper dimensioning of filters is a precondition for energy efficient functioning of pneumatic systems (Golubović et al., 2007). Improperly dimensioned filter can cause either disabling the system from fulfilling its task, or partial usage with higher investment costs. Each filter should be dimensioned in accordance with exploitation conditions and final conditions of filtration.



It is possible to present general guidelines for the selection of the right filter. However, it is advisable to comply with the filter manufacturer's requirements. If the filter manufacturer gave no recommendations, it is recommended to follow the general guidelines listed in table 1.

Filter type	Removal	Max. $\Delta P$ at operating pressure of 7 bar	Special demands
Regular filters	Particles	0,14 - 0,5	No
Coalescent	Particles and fluids	0,17 - 0,7	Regular pre-filter
Absorption	Fumes and odours	0,0017 - 0,13	Regular and coalescent pre-filters
Microbiological	Biological load	3,0 - 5,3	Regular, coalescent and absorption pre-filters

**Table 1.** General guidelines for the selection of the filter type concerning energy efficiency

The maintenance of all components of the pneumatic system is a precondition for its energy efficient functioning. The malfunctioning of one component in a pneumatic system can generate new pollutants that emerge from component wear and tear (valves, distributor pistons, sealing etc.). In such system filters are subjected to additional load, which is not accounted for in filtration design and their life cycle would be shortened.

If filtering elements are not changed within a predetermined period an increased pressure drop may occur, which directly influences the increase of energy consumption. The basis of proper maintenance of filtering components is to track their operation. For this purpose, it is necessary to increase or optimise the frequency of filter replacements. The maintenance procedures should involve regular filter inspections and, when needed, their replacements. It is advisable to install the filters containing a visible indicator of a condition of filtering element, and numerous systems have been developed for automatic registering and alarming that indicates that the pressure drop has exceeded the allowed value. An especially interesting possibility is the application of wireless technology where a filter is equipped with wireless communication, which receives the pressure drop data from the differential pressure sensors which measures filter contamination and transmits a warning in case excessive contamination has occurred. Equipment maintenance personnel need not, in this case, to check for every individual filter but to carry a wireless receiver which receives the information about contaminated filter.

Wireless filter monitoring system (WFMS) for compressed air filters based on a very low power consumption microcontroller was developed on the Faculty of Technical Sciences in Novi Sad. This system is intended for decreasing of the energy loss due to pressure drop caused by filter clogging. The proposed system consists of two separate units (sensor and base), which constantly monitor the filters, see Fig. 1. WFMS is very easy to install in the existing manufacturing systems. It is simple, low cost, flexible, portable and efficient for production, installation in the existing plant, and use (Ignjatović et al., 2012).



**Figure 1.** Wireless filter monitoring system

### 3.7. Designing the overall system

The goal of a proper system design is to adjust the pressure, quantity and quality of compressed air to the needs of different users at their points of use. Although this can be a very simple task, complications are possible in cases when different end users have different or varying consumption needs. Arising problems in system design are:

- One or multiple pressure levels within a system. Typical systems are designed to deliver the air according to the highest pressure and quality required by an end user. This approach can cause unnecessary expenses of energy if air prepared in such a way is required only by a small portion of consumers. The alternative solutions may be:
  - To build a system that delivers lower pressure and to install a pressure amplifiers for those consumers which require higher pressure.
  - To provide and install separate compressor for devices that require higher pressure.
- Limitation of the pressure variations. Inadequate control systems may produce large pressure oscillations which in turn consume an excessive amount of energy. When certain consumers have stochastic demand, the solution could be found in installation of an additional reservoir close to those consumers in order to reduce pressure variations.

### 3.8. Reduction of pressure losses due to pipeline friction

Pressure losses in compressed air distribution network mostly depend on several factors: topology (ring or network, etc.), geometry (pipeline diameter, curvature radius), materials used, etc. The proper designing and realisation of distribution network can optimise the friction losses. Regardless of the importance of a network, a majority of the existing compressed air systems has poor distribution networks due to various reasons:

- During the period of factory construction, the compressed air distribution network is often designed and installed by the companies that perform all other fluid related installation works. These companies are often poorly qualified for designing and installation of compressed air distribution network.
- Under-dimensioned pipelines are occurring very often. Even the systems that were initially well designed, become the "energy devourers" if the compressed air consumption is constantly increased and exceeds the level for which the system was initially designed.





- The lack of valves for interrupting the compressed air supply to the parts of the system being no longer in use or for machines that are not operated in second or third shift.

Since it is difficult and expensive to improve the existing network, proper designing and installation, which encompasses predictions for future system expansions, represent a significant factor for building of a good system.

### 3.9. Reduction of air leakage

Reduction of air leakage is probably the most important measure for obtaining energy savings that are applicable to most of the systems. The awareness regarding importance of introducing regular leakage detection programs is on a very low level, partially because these spots are difficult to visualize and partially because they do not cause direct damage. Leakages can lead to requirements for additional increase of compressor capacity and to increased compressor operating time. If pressure within a system drops below minimum level, the devices utilizing compressed air can be less efficient and equipment life cycle can be shortened, and in some cases breakdown of production lines may occur. In typically well maintained plants, leakages range between 2 and 10% of total capacity, but can amount up to 40% in the plants that are not maintained properly. It is considered that leakage can be tolerated while being less than 10% of total production. An active approach that involves permanent leakage detection and appropriate maintenance work can reduce the leakage to this level. The causes of air leakages are: employees' negligence, poor system design and poor system maintenance.

Table 2 can serve as a guideline in evaluating the scope of losses that arise due to leakage. In this example, it is assumed that the price of electrical energy is 0.1 €/kWh (costs of industrial electrical energy in EU average to 0.09 – 0.12 €/kWh) and that system is operated at 8,000 hours/year, while the price of compressed air preparation is 0.02 €/m<sup>3</sup>.

Orifice diameter	Air loss with 600 kPa (6 bar)			Production costs €/year	Costs of production, preparation and distribution €/year
	Actual size	l/min	m <sup>3</sup> /h		
 1	80	4.8	0.4	320	768
 3	670	40	4	3,200	6,432
 5	1,857	111	10	8,000	17,827
 10	7,850	471	43	34,400	75,360

**Table 2.** Costs of compressed air leakages (Lau, 2006)

Proper design and installation of network can eliminate leakage spots to a great extent, for example, with application of contemporary devices for condensate removal without air loss or by specifying high quality fast decomposing junctions. Awareness must be kept towards the fact that leakage continuously increases after the reparation has been made. The leakage is increasing with the same rate, regardless of whether the reparations are executed or not.

Removing leakage sources is based on detecting and repairing locations of leakage and removing the root causes that generated leakage within the system. Proper maintenance is of essential importance when fighting leakages and a good program for leakage detection can prevent unexpected failures from happening and reduce downtimes and losses. In many cases leakage is easily detected because large leakages are audible. Small and very small leakages are hard to detect and are hardly audible. In those cases, the elements of the system should be checked by some of the methods for leakage detection. The methods for detection of compressed air leakage are:

- Leakage detection via sense of hearing,
- Leakage detection via bubble release,
- Ultrasonic detection and
- Infrared leakage detection (Dudić et al., 2012).

The most significant of all these methods is an ultrasonic method that utilizes a special detector that is shown on Figure 2. Figure 3 shows the examples of operating the ultrasonic leakage detector.



Technical characteristics:

- Indicator: 10 segment LED Bar Graph (red)
- Sensitivity selection: 8 position precision attenuation
- Operating temperature range: -30° to +75° C
- Frequency range: 300 tp 3,000 Hz
- Response time: 300 ms

**Figure 2.** The ultrasonic detector kit for Ultraprobe 100



**Figure 3.** Examples of utilisation of ultrasonic detector



### 3.10. Reduction of operating pressure

Higher pressures increase leakage, and thereby the expenses. Usually, an increase of operating pressure is used to compensate for lack of capacity. The actual effect is quite opposite to the desired one. The higher pressure, higher is leakage, while the irregular consumers consume more air, and thus more energy. Each 1 bar of the pressure increase is followed by an increase in electrical energy consumption required to compress the air in a range between 5% and 8% (Šešlija et al., 2011).

If the consumers are allowed to independently determine the amount of their need for compressed air, this system will never operate in an efficient manner, because everybody will be misled by the fact that they can obtain the pressure of any desired amount in any desired quantity. Higher air flow and higher pressure impose higher costs. The characteristic situation in which it is possible to solve this problem is one in which there is one or a small number of consumers in a requirement for higher pressure. In this case, it is suggested to install a secondary, smaller, high pressure unit or an appropriate amplifier (pneumatic booster), instead of operating the compressed air system of the whole factory on the higher level of pressure.

### 3.11. Unsuitable applications of compressed air

Compressed air is extensively misused for applications in which it is not energy efficient, for which better solutions exist or, its implementation is incorrect in the places where its usage is justified. Compressed air is the most expensive form of energy in a plant but its good characteristics, such as simplicity in application, safety of operation and availability in the whole plant area, often lead people to apply it even where more cost effective solutions exist. The users should therefore, always primarily consider the cost effective energy sources before applying the energy of compressed air. Table 3 gives examples of unsuitable usage of compressed air and alternative solutions that should be applied instead.

Figure 4 shows an example of unsuitable application of compressed air. Nozzles are positioned above the line for bakery products in order to clean the product from the powder present and in order to cool it.

The nozzles themselves present an energetically unfavourable solution and an effort should be made to replace it with another solution. In this case, a fan could be used. Furthermore, if usage of nozzles is insisted upon, it's more energy efficient version should be used.

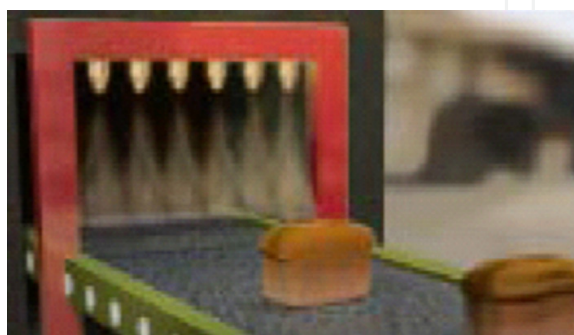

**Figure 4.** Cleaning of bakery products with compressed air (Norgren, 2011)

Unsuitable application of compressed air	Alternative solution
Control cabinet cooling	Ventilating, air conditioning
Cooling, aspiration, agitation, mixing, packaging blow-out	Blowers (customized compressors that produce compressed air in large quantities)
Vacuum production by Venturi pipe	Vacuum pump or application of Venturi method with appropriate, energy efficient control
Cleaning of parts and processing residuals removal	Brushes, blowers, vacuum system
Removal of parts from the moving production line by nozzles	Blower, electrical actuator or pneumatic cylinder
Blower guns	Blowers, cups or application of reduced pressure air (installing the pressure regulators on guns or constructing low-pressure network)
Pneumatic tools	Electrical tools are more energy efficient although they have lowered torque control possibilities, shorter life time and are not inherently safe
Air knives	High pressure blowers that are automatically turned off when cutting object is absent
Powdered materials transport (pneumatic transport)	Electrical blowers
Vibrating the walls of powdered and granulated materials	Electrical vibrators

**Table 3.** Unsuitable applications of compressed air and the alternative solutions

Fig. 6 shows that nozzles are positioned too high so that higher flow of compressed air is needed to accomplish the task, which means that for product of different heights the nozzle carrier frame height should be adjusted. Finally, it is necessary to set the active control over nozzles that will allow the air to flow based on sensor that signals the presence of a bakery product, in contrary to situation from Fig. 6 where it can be seen that the air is flowing and that no bakery product is present beneath. Other unsuitable uses of compressed air involve unregulated consumers, supplying abandoned equipment or equipment that will not be used for a prolonged period of time, etc.

*Unregulated consumers* - This covers all places of usage in which compressed air can be directly released by opening a valve, all places where leakages are present, etc. For example, in applications with pneumatic tools, if the pressure regulator is not installed, the tool will use the full network pressure and this pressure might be significantly higher than the level required for its operation (for example, 8 bars instead of 5.5 bar). Furthermore, this kind of pressure increase leads to greater equipment wear, which leads to greater maintenance costs and reduction of the equipment life cycle.



*Abandoned equipment* - From time to time, reconstructions occur in factories that often lead to abandonment of some parts of compressed air equipment leaving the air supply pipeline intact. The airflow going through the pipeline to the abandoned piece of equipment should be interrupted, as close as possible to the air supply source, because it will inevitably generate some leakage and create unnecessary losses.

### 3.12. Optimisation of devices that consume compressed air

Many devices that consume compressed air can be used in a more energy efficient manner. The optimisation of devices that consume compressed air is one aspect of systemic approach (Šešlija, 2003) to designing a compressed air system. The optimisation can be achieved by: replacing the existing components with more energy efficient ones; installing the additional elements, and better use of existing components.

For example, in the case of applying a vacuum generator, the savings in the compressed air are realised by using more energy efficient components, which have an integrated vacuum switch with an air saving function - example is Air saving circuit (Festo, 2011). The vacuum range is set on the vacuum switch. The switch generates a pulsating signal which actuates the solenoid valves for vacuum when the vacuum pressure has fallen below the selected upper limit value (due to leakage etc.). At all other times, the vacuum is maintained with the non-return valve, even when the vacuum generator is not switched on. Fig. 5 presents the operational diagram for vacuum pump and vacuum generator with implemented Air saving function. Since the price of vacuum produced in this way is too high and vacuum suction elements represent significant consumers of compressed air, this option contributes to the increase of energy efficiency of the system. The savings are proportional to participation of time  $\Delta t$ , shown in Fig. 5, within a total time of holding the working object. This solution is especially suitable for application in which time of holding an object significantly participates in the total cycle of material handling.

Using contemporary engineering tools for supporting the design of vacuum applications, it can be analysed the change of system parameters or parameters of devices that are installed in the system. For example, by using the FESTO vacuum engineering module, for manipulation of an object with a cylindrical shape whose dimensions are: diameter of 150 mm, height of 40 mm and weight of 200 g, a total of 6 vacuum cups are needed. The change of operation pressure enables the usage of highest vacuum level. Air consumption, in the case of 6 bar pressure (see Fig. 6 left) is 27.60 l/min, while with the pressure of 5.4 bar (see Fig. 6 right) is 23.28 l/min.

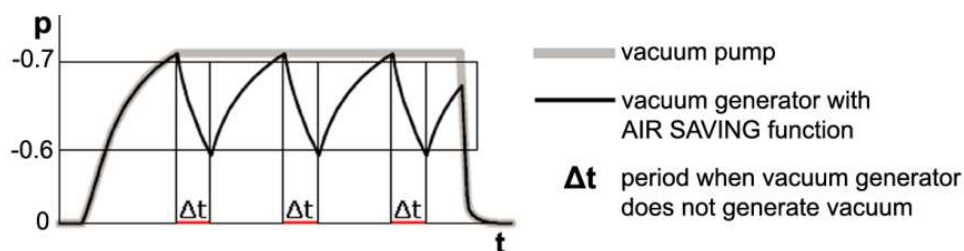

**Figure 5.** Operation of vacuum pump and vacuum generator with implemented Air saving function

In these way savings of 4.32 l/min, or 0.072 l/s of compressed air are accomplished. If vacuum cups operate for 30 s every minute, 8 h/day, 250 days/year, 259,200 l of compressed air savings could be achieved for a year. This represents the savings for engagement of one group of vacuum cups for manipulating one workpiece on one workplace. The production processes often use a larger number of vacuum cups. Therefore, the amount of compressed air that could be saved is significantly higher (Ignjatović et al., 2011).

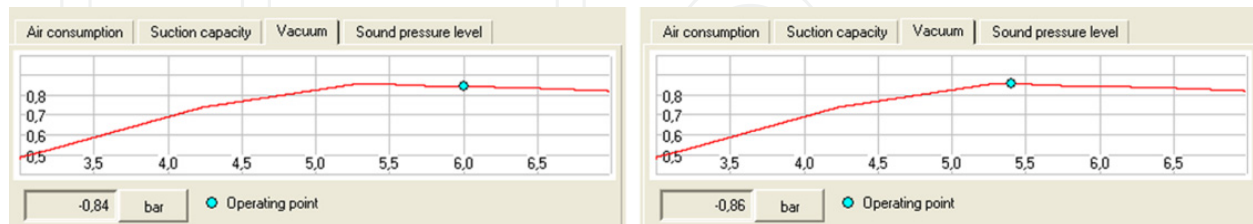

**Figure 6.** Vacuum level at operating pressure of 6 bar (left) and 5.4 bar (right)

### 3.13. Optimising the control system at the point of use

In traditional design of pneumatic control system there were no concerns about energy efficiency. Several approaches are developed for energy efficient control of pneumatic systems. Here we will stress only two: Optimising servo-pneumatic systems using PWM and Recycling of used compressed air.

#### 3.13.1. Optimising servo-pneumatic systems using PWM

If servo control is required by means of pneumatic actuator, it is necessary to use proportional valve in order to control pressure in cylinder chambers. Regardless of the type, the proportional valve is the most expensive component of pneumatic servo system (Liu and Bobrow, 1988; Lai et al., 1990).

Instead of proportional valves and servo valves, on/off electromagnetic valves (2/2 or 3/2-way) are being investigated in order to develop cheap pneumatic servo systems. On/off electromagnetic valves take either entirely open or entirely closed position according to electric command. A pneumatic actuator with on/off electromagnetic valves can be controlled by Pulse Width Modulation (PWM) (Barth et al., 2003; Shen et al., 2004).

The control of pneumatic actuator by means of PWM enables servo control by on/off electromagnetic valves at significantly lower cost than the cost of the control done by proportional valves. If response rate and positioning accuracy are taken into account, the results obtained by PWM control are approximately the same as the results obtained by proportional control.

In the case of proportional valve based systems, the fluid flow is continuously varied. In the case of PWM-controlled systems, the valve is entirely open or entirely closed while the control is done by time of keeping the valves in final positions. Thus, the valve delivers discrete quantity of fluid mass whose size depends on control signal. If the frequency of valve opening and closing is much higher than boundary frequency of the system, the system responds to mean value of discrete flow which is the case of continuous flow, too. With

on/off electromagnetic valves controlled by PWM it is possible to develop a multifunctional pneumatic system having acceptable price and performances (Šitum et al., 2007).

The results obtained in (Čajetinac et al., 2012) show that PWM principle of control gives a good quality of the signal tracking at the considerably lower costs and that PLC with standard program support can be used for its realization. It has been shown that it is possible to achieve control performances which are comparable to those achieved by proportional or servo valve but at rather lower cost and with better energy efficiency. Thus these methods of control may be applied as well as pneumatic servo systems since the described system is relatively new and expanding.

### 3.13.2. Recycling of used compressed air

Pneumatic actuators are widespread in many branches of industry and a lot of efforts are done in order to increase energy efficiency in their operation. It is a known fact that pressure inside a piston chamber can reach a final value that is equal to supply pressure, only after some time being at the end position of the cylinder piston has been reached. When the direction of movement of the cylinder piston is reversed, all the compressed air contained within a working volume is released into the atmosphere. This represents a significant loss of compressed air that possesses enough potential energy to perform some other kind of work. There is a possibility to reuse this kind of compressed air, see Fig. 7 (Blagojević et al., 2011).

The performance of the system with restoring energy can be improved in comparison with the traditional control system. Compressed air consumption saving of the conventional pneumatic system with restoring energy is from 33.3% to 44.3% or average 38.8%, for 200 to 600 kPa range of pressure supply. Compressed air consumption saving of the pneumatic servo system with restoring energy is from 20.6% to 33.3%, or average 28.6% for 200 to 600 kPa range of pressure supply. If the system is using pressure of nominal operating value that is 600 kPa than the average compressed air consumption saving is 41.9 % for conventional system and 30.6% for servo system. Return of investment periods of the proposed conventional pneumatic system with restoring energy are average 2.45 years. If the actuator of the conventional system is rodless or trough rod cylinders or semi-rotary drive, and if there is no load, which can be used for support of actuator movement, the saving is less than 5%.

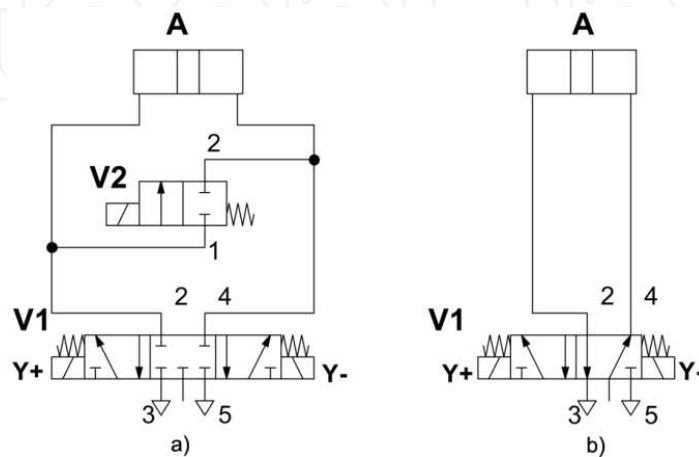

**Figure 7.** Pneumatic circle a) with restoring energy, b) without restoring energy (Blagojević et al., 2011)

### 3.14. Measuring and recording the system performance

Measuring and recording the system performance, by itself, does not increase the energy efficiency but usually presents a first step towards improvements in energy efficiency because of two primary reasons:

- Measuring the air consumption and energy used for its production is of essential importance for determination, whether the changes in maintenance practice or equipment investments have justified their costs. As long as the price of a unit of consumed compressed air remains unknown, it is difficult to initiate the managerial processes necessary for improving the system.
- Recording the system performance is a valuable tool for discovering the degradation in performance or changes in quantity or quality of used compressed air.

Three basic parameters – airflow, air pressure and consumption of electrical energy, must be measured and recorded in order to evaluate the system performance. Although this might look simple, in principle, the interpretation of these data can present a difficulty, especially under conditions of variable consumption. Measurement of flow of compressed air also involves certain technical problems and retrofitting reliable measurement instruments can be difficult if not impossible task, unless it was taken care of during the phases of system design and installation. For example, most frequently used type of flow meter must be installed into the pipeline sections that are free of turbulence and whose length must be 10 times greater than its diameter. In some systems, there is not an adequate place for installing of a flow meter. Because of that, it is suggested that large systems and medium size systems must be designed and installed in such a way to enable air flow measurements. If the flow data is not available, the cheaper alternative equipment used for pressure measurement can be very useful to, for example, measure the pressure drop over filters or pressure loss along the pipeline, or for the purposes of detecting larger variations of pressure within the system.

## 4. Increasing energy efficiency in complex robotic cell

Increase of energy efficiency in compressed air systems is often connected with optimisation of the whole automated system. That is particularly the case with the complex automated systems such as robotic cell and robotic line. In such applications are often integrated, besides robots, pneumatic and hydraulic systems. Minimisation of energy consumption is done in most cases up to now, separately for the each subsystem. There are numerous references dealing with trajectory optimisation of industrial robots, influence of the robot velocity on energy efficiency and design of the optimal components layout within the robotic cell (Šešlija, 1988; Tomović et al., 1990; Yoshimura, 2007; Guilbert et al., 2008; Kamrani et al., 2010; Wenger and Chedmail, 1991; Dissanayake and Gal, 1994; Aspragathos and Foussias, 2002).

As well for the optimisation of operation of hydraulic systems concerning efficiency increase it is of significance to monitor the system operating parameters and to increase the reliability of components (Jocanović et al., 2012).

Having in mind the fact that compressed air is widely used in robot applications, it could be naturally that there are many possibilities for savings and its efficient usage. In that manner we can describe an example of a robotic cell (Fig. 8) optimisation with installed electric and pneumatic devices (Mališa et al., 2011).

The key step is to define the parameters within a robotic cell that affect electricity and/or compressed air consumption, e.g. robot's velocity, device activity, movement trajectories, position of the robot relatively to working area; pressure of compressed air; suction capacity (in the case of vacuum); length of the supply tubes, etc. As various factors are present there are three different ways for optimisation of such complex robotic cell. First approach is the most common case when two independent experts (usually robotic expert and pneumatic expert) optimise the parameters in their domain in parallel. Second approach encompasses firstly the optimisation of the parameters that influence the compressed air consumption, and than parameters that influence the electricity consumption. The third method includes optimisation of the parameters influencing the electricity consumption, and after that, adjusting the parameters related to compressed air.

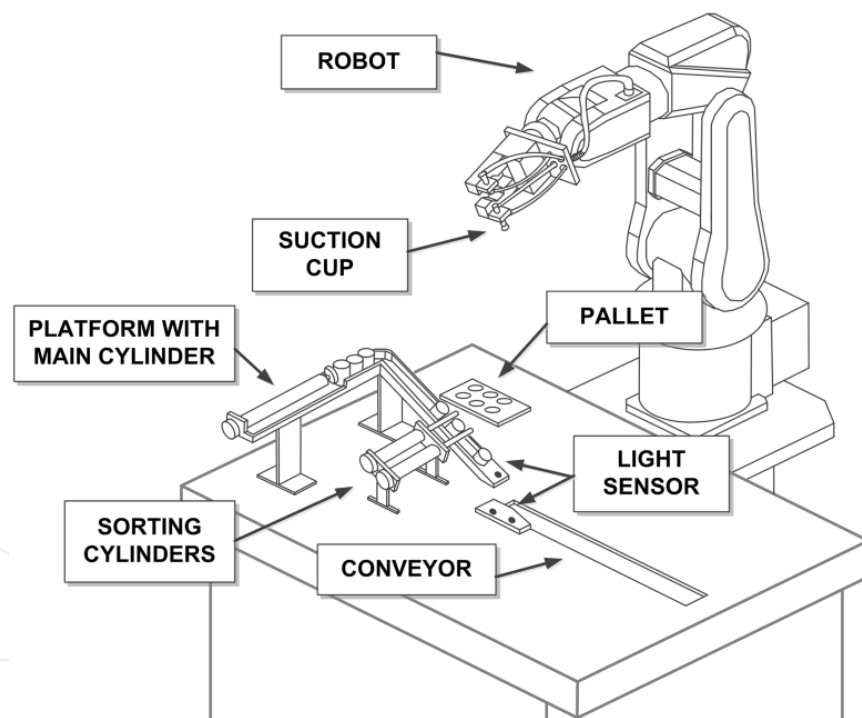

**Figure 8.** Complex robotic cell

Doing the experiments that would have confirmed one of the mentioned approaches, it was realised that, electric and compressed air parameters could not be observed separately, because most of them influence each other. For instance the adoption of the lowest robot velocity, as the lowest electricity consuming, would disregard the most important principle of a production system: productivity. On the other hand, the highest robot velocity would ensure the highest productivity of the robotic cell, but it would induce the problems with



pneumatic devices which would not be able to serve the process, especially if pneumatic devices are set to be the lowest energy consuming. Theoretically, the minimum pressure gives the minimum energy consumption and this could be a pressure of 3 bar, because most of the nowadays devices are able to work on low pressures. The importance of problem could be described with example of vacuum application. For the high robot's velocities, working pressure of 3 bar could not provide a sufficient vacuum level for the amount of time determined by the process.

After the numerous experiments and analysis it is concluded that complex robotic cells that use electricity and compressed air for their operation should be optimised as follows. Firstly, parameters that influence the electricity consumption should be optimised. Secondly, parameters related to compressed air consumption should be adjusted according to constraints given by the robot and working regime. Applying the suggested optimisation method on the complex robotic cell, including the various parameters within it, is possible to significantly reduce the overall energy consumption. For example, in the considered complex robotic cell, with the reduction of the supply pressure from 6 to 4 bar, it is possible to decrease total air consumption by 15%.

## 5. The potential of applying the measures for energy efficiency increase

Measures for increasing energy efficiency of compressed air systems are related to different phases of the life cycle of a compressed air system:

- System design, gathering of offers or purchasing,
- System installation,
- Significant changes in components or system improvement,
- Preventive and corrective maintenance.

The greatest potential for achieving the savings exists in times of conceiving a new system because at that moment a great spectrum of energy saving measures, described in the table below, is available. This kind of situation is relatively rare, because new factories are not continuously built so even the best opportunity for systematic design becomes rarely available (first column in table 4). Table 4 gives approximate indications of phases in which each of described measures can be applied.

Much frequently encountered is the case of replacing the main components of the existing system. In this kind of situation, it is possible to implement many measures, some of which are faced with greater difficulty especially the ones that are related to system design: compressed air distribution network, systems with multiple pressure levels, selection of the type of end consumer, etc. It is estimated that the possibility for savings in the existing systems, in the time of replacement of main components, amounts to 2/3 of the efficiency increase that could be realized in a new system that would be designed with initially having energy efficiency in mind (Radgen and Blaustein, 2001).



	System design acquisition	Installatio n	Component replacement	Maintenanc e
Improvement of drives	++		++	+
Optimal choice of compressor	++		+	
Sophisticated control system	++		++	
Recuperating waste heat	++		++	
Improvement in air treatment	++		++	++
Overall system design	++		+	
Optimising end use devices	++		+	
Reducing frictional losses	++	+	+	
Reducing air leaks	+	+	+	++
Measuring system performance	++		+	++

**Table 4.** The applicability of energy saving measures in specified phases of a compressed air system life cycle (Radgen and Blaustein, 2001).

Some measures for energy savings can be implemented into the existing systems in any moment. These are, for example, implementation of sophisticated control systems or waste heat regeneration. The procedures related to maintenance and system operation, especially the frequency of filter replacement, represents one of the main sources for energy savings. These measures can also be implemented at any time during a life cycle of compressed air system components. Table 5 gives the estimate of applicability of these measures based on opinion of the larger number of experts (USDOE, 2001). Only the estimates of the average savings in relation to most significant measures for increasing energy efficiency are given, given that the return of investment time is less than 3 years.

Energy saving measures	Applicability %		Gain %	Potential contribution
	From – to	Average		
Reduction of overall system requirements	20 - 40	30	20	6.0
Match compressor and load	5 - 15	10	3	0.3
Improvements of compressor control	15 - 40	25	10	2.5
Improvement of compressor components	5 - 20	15	5	0.8
Operation and maintenance	50 - 85	75	10	7.5
Total savings				17.1

**Table 5.** The experts estimate of the average energy savings for compressed air systems in relation to most significant measures (USDOE, 2001).

## 6. Conclusion

Compressed air systems represent a significant segment of production and service systems. Therefore, it is necessary to pay attention to their energy efficient operation. The application of the measures for an energy efficiency increase in compressed air systems enables prolongation of the component's life cycle and the reduction of total operation costs that in turn increases the economic quality of working process. The procedure that was presented and explained in detail, containing cost effective activities illustrated with appropriate examples, can significantly increase the energy efficiency of compressed air systems.

## Author details

Dragan Šešlija, Ivana Ignjatović and Slobodan Dudić  
*Faculty of Technical Sciences, University of Novi Sad, Republic of Serbia*

## 7. References

- Aspragathos, NA. & Foussias, S. (2002). Optimal Location of a Robot Path when Considering Velocity Performance. *Robotica*, Vol.20, No.2, pp.139-147, ISSN 0263-5747
- Barth, J., Zhang, J. & Goldfarb, M. (2003). Control Design for Relative Stability in a PWM-Controlled Pneumatic System. *ASME Journal of Dynamic Systems, Measurement, and Control*, Vol.125, No.3, pp. 504-508, ISSN: 0022-0434
- Blagojević, V., Šešlija, D. & Stojiljković, M. (2011). Cost Effectiveness of Restoring Energy in Execution Part of Pneumatic System, *Journal of Scientific & Industrial Research*, Vol.70, No.2, , pp. 170-176, ISSN (Online) 0975-1084
- Čajetinac, S., Šešlija, D., Aleksandrov, S. & Todorović, M. (2012). PLC Controller used for PWM Control and for Identification of Frequency Characteristics of a Pneumatic Actuator, *Elektronika Ir Elektrotehnika*, (Article in press), ISSN 1392 – 1215
- De Keulenaer, H., Belmans, R., Blaustein, E., Chapman, D., De Almeida, A., De Wachter, B. & Radgen, P. (2004). *Energy Efficient Motor Driven Systems*. European Copper Institute, Retrieved from  
 <<http://www.copperinfo.co.uk/motors/downloads/pub-176-energy-efficient-motor-driven-systems.pdf>>
- Dissanayake, M. & Gal, J. (1994). Workstation Planning for Redundant Manipulators. *International Journal of Production Research*, Vol.32, No.5, pp. 1105-1018, ISSN 0020-7543
- Dudić, S., Ignjatovic, I., Šešlija, D., Blagojević, V. & Stojiljković, M. (2012). Leakage Quantification of Compressed Air Using Ultrasound and Infrared Thermography. *Measurement*, (Article in Press), ISSN 0263-2241
- EPS-Electric Power Industry of Serbia (2009a). *Technical annual report*, Available from  
 <<http://www.eps.rs/GodisnjiIzvestaji/SRB%202009%20web1.pdf>>
- EPS-Electric Power Industry of Serbia (2009b). *Prices*
- Festo. (2011). *VADM/VADMI product datasheet*, Festo AG&Co.KG, Retrieved from  
 <[http://xdki.festo.com/xdki/data/doc\\_ENUS/PDF/US/VADM\\_ENUS.PDF](http://xdki.festo.com/xdki/data/doc_ENUS/PDF/US/VADM_ENUS.PDF)>

- Lau, L. (2006). *Energy Saving, P.BE-FESS-01-EN*. Festo AG&Co.KG
- Gloor, R. (2000). *Energy Savings in Compressed Air Systems in Switzerland*, Electricity Research Program (project number 33 564), Swiss Federal Office of Energy
- Golubović, Z., Šešlija, D., Milovanović, B., Majstorović, B. & Vidovic, M. (2007). The Challenges in Sterile Pressurised Air Preparation, *Proceedings of PAMM – Conference*, pp. C152-153/2007, Balatonalmadi, Hungary, 31 May-3 June 2007
- Guilbert, M., Joly, L. & Wieber, PB. (2008). Optimisation of Complex Robot Applications under Real Physical Limitations. *The International Journal of Robotics Research*, Vol.27, No.5, pp. 629-644. ISSN 0278-3649
- Henning, D. (2005). *Electricity - What and How Much in Swedish Industry*. A Project of Energy Authority's Research Program, Swedish Energy Agency
- Ignjatović, I., Šešlija, D., Tarjan, L. & Dudić, S. (2012). Wireless Sensor System for Monitoring of Compressed Air Filters, *Journal of Scientific & Industrial Research*, Vol. 71, No.5, pp. 334-340, ISSN (Online): 0975-1084
- Ignjatović, I., Šešlija, D. & Dudić, S. (2011). Increasing energy efficiency of compressed air usage for sustainable production of food and beverage. *Acta Technica Corviniensis*, Faculty of Engineering Hunedoara, Vol.4, No.2, pp. 61-65, ISSN: 2067-3809
- Jocanović, M., Šević, D., Karanović, V., Beker, I. & Dudić, S. (2012). Increased Efficiency of Hydraulic Systems through Reliability Theory and Monitoring of System Operating Parameters, *Strojniški vestnik - Journal of Mechanical Engineering*, (Article in press), ISSN 0039-2480
- Kamrani, B., Berbyuk, V., Wäppling, D., Feng, X. & Andersson, H. (2010). Optimal Usage of Robot Manipulators. in *Robot Manipulators Trends and Development*, Jimenez A, Al Hadithi BM. pp. 1-26, INTECH, Retrieved from <<http://www.intechopen.com/books/robot-manipulators-trends-and-development/optimal-usage-of-robot-manipulators>>
- Kulterer, K. & Weberstorfer, C. (2007). Motor Challenge Programme in Austria–Improving industrial energy efficiency, *Proceedings of eceee 2007. Summer study. Saving energy – just do it!*, pp. 1509-1517, ISBN 978-91-633-0899-4, La Colle sur Loup, France, June 4–9, 2007
- Lai, JY., Menq, CH. & Singh, R. (1990). Accurate Position Control of a Pneumatic Actuator, *Journal of Dynamic Systems, Measurement, and Control*, Vol.112., No.4, pp. 734-739, ISSN 0022-0434
- Li, L., Yuqi, L., McKane, A. & Taranto, T. (2008). *Energy efficiency improvements in Chinese compressed air systems*, Lawrence Berkeley National Library, University of California eScholarship Repository 2008; Paper LBNL-63415, Available from <<http://escholarship.org/uc/item/0v72z2q0>>
- Liu, S. & Bobrow, JE. (1988). An Analysis of a Pneumatic Servo System and Its Application to a Computer-Controlled Robot, *ASME Journal of Dynamic Systems, Measurement, and Control*, Vol.110, No.3, pp. 228-235, ISSN 0022-0434
- Mališa, V., Komenda, T. & Ignjatović, I. (2011). Energy Efficient Automation on an Example of a Demo Robot Cell, *Proceedings of International Scientific Conference on Industrial Systems*, pp. 97-100, ISBN 978-86-7892-341-8, Novi Sad, Serbia, September 14-16, 2011
- McKane, A., Scheihing, P., Cockrill, C. & Tutterow, V. (1997). *US Department of Energy's Motor Challenge: Developed with Industry for Industry*, Lawrence Berkeley National Library,

- University of California, Industrial energy analysis, Paper LBNL-43887, Available from <<http://industrial-energy.lbl.gov/files/industrial-energy/active/0/LBNL-43887.pdf>>
- Mitrović, Č., Golubović, Z. & Šešlija, D. (2006). Implementation, Significance and Effects of Filtration in Industry, *Research and Design for Industry*, Vol.12, No.4, pp. 13-20, ISSN 1451-4117
- Norgren. (2011). *Energy Saving, The Norgren guide to saving energy and cutting costs in compressed air systems*, Norgren Engineering Advantage, USA
- Radgen, P. (2004). Compressed Air System Audits and Benchmarking. Results from the German Compressed Air Campaign "Druckluft effizient". *Proceedings of ECEMEI, Third European Congress on the Economics and Management of Energy in Industry*, Rio Tinto, Portugal, April 6-9, 2004
- Radgen, P. (2003). The "Efficient Compressed Air" Campaign in Germany - Market Transformation To Activate Cost Reductions And Emissions Savings. *Proceedings ACEEE Summer Study on Energy Efficiency in Industry*, pp. 3-194-205, Rye Brook, New York, July 29 - August 1, 2003
- Radgen, P. & Blaustein, E. (2001). *Compressed Air Systems in the European Union, Energy, Emissions, Saving Potentials and Policy Actions*. LOG-X Verlag GmbH, ISBN 3-932298-16-0, Stuttgart, Germany
- Shen, X., Zhang, J., Barth, EJ. & Goldfarb, M. (2004). Nonlinear Averaging Applied to the Control of Pulse Width Modulated (PWM) Pneumatic Systems, *Proceeding of the 2004 American Control Conference*, pp. 4444 – 4448, Boston, Massachusetts, USA, June 30-July 2, 2004
- Šešlija, D. (2003). The System Approach to the Pneumatic System Energy Efficiency, *Procesna Tehnika*, Vol.19, No.1, pp. 237-240, ISSN 0352-678X
- Šešlija, D. (2002a). *Production, Preparation and Distribution of Compressed Air*, IKOS, Novi Sad
- Šešlija, D. (2002b). Quality of Compressed Air in Advanced Automated Systems, *Proceedings of International Scientific Conference on Industrial Systems*, pp. 158-163, Vrnjačka Banja, Serbia, October 22-23, 2002
- Šešlija, D. (1988). Industrial Robot Programming in Assembly Using GT Approach. *Strojarstvo*, Vol.30, No.5/6, pp. 243-247, ISSN 0562-1887
- Šešlija, D., Ignjatović, I., Dudić, S. & Lagod, B. (2011). Potential Energy Savings in Compressed Air Systems in Serbia, *African Journal of Business Management*, Vol.5, No.14, pp. 5637-5645, ISSN 1993-8233
- Šešlija, D., Stojiljković, M., Golubović, Z., Blagojević, V. & Dudić, S. (2009). Identification of the Possibilities for Increasing Energy Efficiency in the Compressed Air Systems. *Facta Universitatis, Series Mechanical Engineering*, Vol.7, No.1, 2009 pp. 37-60, ISSN 0354 – 2025
- Šešlija, D., Stojiljković, M. & Golubović, Z. (2008). Increase of Energy Efficiency in HIPNEF Systems, *Proceedings of Congress with International Participation HIPNEF*, ISBN 978-86-80587-87-5, pp. 3-15, Vrnjačka Banja, Serbia, October 15-17, 2008
- Šitum, Ž.; Žilić, T. & Essert, M. (2007). High Speed Solenoid Valves in Pneumatic Servo Applications, *Proceedings of the Mediterranean Conference on Control & Automation*, pp. T06-001, Athens, Greece, July 27-29, 2007

- Tomović, R., Zelenović, D. & Šešlija, D. (1990). The Role of Intelligent Robots in Flexible Assembly. *Computers in Industry*, Vol.15, No.1–2, pp. 131–139, ISSN 0166-3615
- USDOE-US Department of Energy (2001). *Assessment of the Market for Compressed Air Efficiency Services*, DOE/GO-102001-1197, Washington DC, USA, Available from <[http://www1.eere.energy.gov/manufacturing/tech\\_deployment/pdfs/newmarket5.pdf](http://www1.eere.energy.gov/manufacturing/tech_deployment/pdfs/newmarket5.pdf)>
- USEIA-US Energy Information Administration (2006). *Independent Statistics and Analysis. International Energy Annual 2006. International and United States Total Primary Energy Consumption, Energy Intensity*, Washington DC, USA, Available from <<http://www.eia.gov/emeu/international/energyconsumption.html>>
- Wenger, PH. & Chedmail, P. (1991). Ability of a Robot to Travel through Its Free Work Space in an Environment with Obstacles. *The International Journal of Robotics Research*, Vol.10, No.3, pp. 214-227, ISSN 0278-3649
- Wissink, E. (2007). *Possibilities for Saving Energy in Part Load*, 's-Hertogenbosch, GEA Grasso B.V., The Netherlands, Available from <<http://www.grasso.nl/en-us/News-and-Media/technical-articles-Grasso/Documents/Possibilities%20for%20saving%20energy%20in%20part%20load.pdf>>
- Yoshimura, M. (2007). System Design Optimisation for Product Manufacturing. *Concurrent Engineering: Research and Applications*, Vol.15, No.4, pp. 329-343, ISSN 1063-293X