

We are IntechOpen, the world's leading publisher of Open Access books Built by scientists, for scientists

4,800

Open access books available

122,000

International authors and editors

135M

Downloads

Our authors are among the

154

Countries delivered to

TOP 1%

most cited scientists

12.2%

Contributors from top 500 universities



WEB OF SCIENCE™

Selection of our books indexed in the Book Citation Index
in Web of Science™ Core Collection (BKCI)

Interested in publishing with us?
Contact book.department@intechopen.com

Numbers displayed above are based on latest data collected.

For more information visit www.intechopen.com



Grid-Connected Wind Park with Combined Use of Battery and EDLC Energy Storages

Guohong Wu, Yutaka Yoshida and
Tamotsu Minakawa

Additional information is available at the end of the chapter

<http://dx.doi.org/10.5772/51521>

1. Introduction

Over the last decade, driven by limited fossil fuel supply, global warming, and the provision of tax credit or financial support for renewable power production, sustainable power generations such as wind power and photovoltaic power etc. have been increasingly integrated into the existing power grids. Among these renewable power generations, wind power has various advantages such as large per unit capacity and easily construction of a large-scale generating station, which lead to a relatively lower generation cost over the other ones, and hence be considered as one of the mature renewable energy alternatives to the conventional fuel-based resources [1]. Fig. 1 and Fig. 2 gives the change tendency of the total introduction capacity and annual introduction capacity of wind power generation in the world [2]. It can be known from these figures that the wind power generation has been significantly increased in the recent years and is expected to increase further in the later future.

However, the main challenge of wind power utilization is associated with the fluctuation and unpredictability in its power generation. Fig. 3 gives a typical wind power output curve based on the measurement data [3]. This data is a good example to obviously indicate the facts that the wind power consists of both considerable fast/short-term fluctuation and slow/long-term variation. Generally, wind parks are located in the remote area and interconnected into the distribution system via a relatively long tie transmission line. Along with the increasing integration of wind power into a power grid, due to the fluctuation of wind power, considerable fluctuation of power flow in the tie transmission line (the line that connects the wind park to the power grid) may occurs and lead to some problems such as power quality degradation, voltage instability and insufficient available power transferability, etc., and hence imposes difficulties both in terms of operation and planning. These issues need to be

resolved adequately to reduce the negative effects on the existing power grid in order to facilitate the increasing integration of wind power into the future power networks.

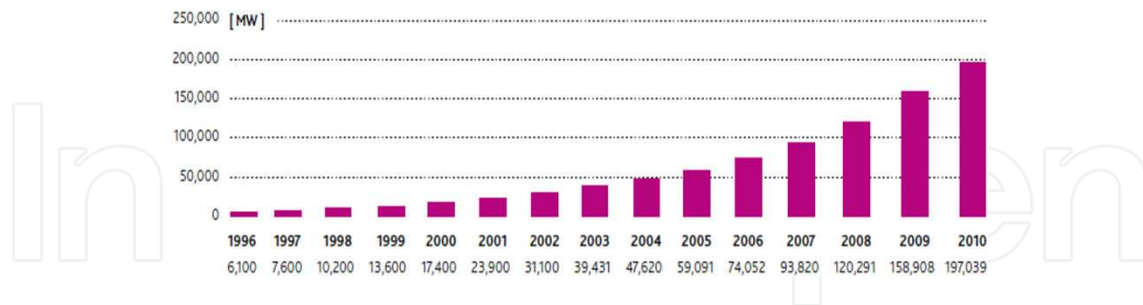

Figure 1. Change of the total introduction capacity of wind power generation in the world [2]

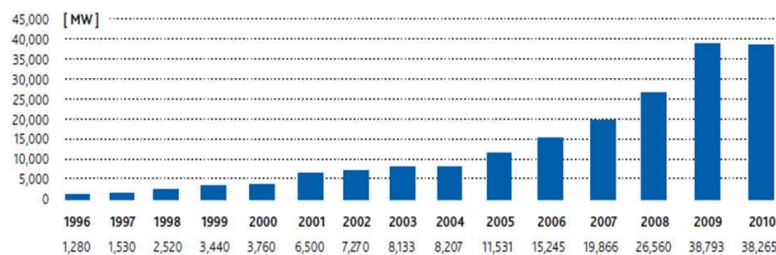

Figure 2. Change of the annual introduction capacity of wind power generation in the world [2]

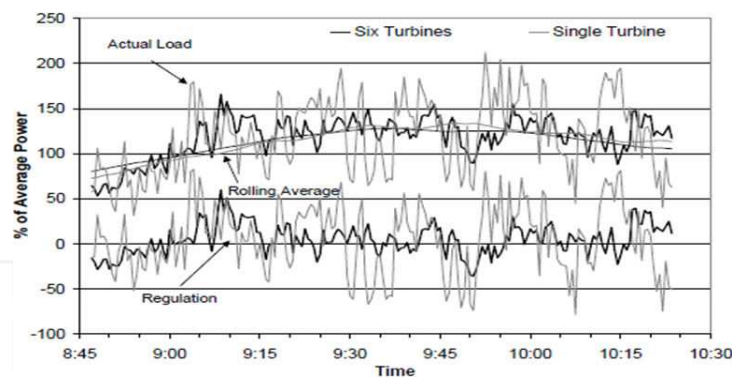

Figure 3. An example of actual power output of a wind plant and a single wind turbine generator [3]

For this purpose, in this chapter, it is considered that energy storage is an effective way for power management and power leveling for a wind park, especially in the case that wind power with significant fluctuation (e.g., at a wind park located in a mountainous region) is integrated into a distribution system with initially weak stability.

The concepts presented in this chapter mainly pay attention to the power leveling and fluctuation mitigation effect by introduction of energy storages. A method that considers the combined use of two types of energy storage devices with different response properties and costs are proposed for a grid-connected wind park. These considered energy storages include:

(1) A secondary electrical battery, which is characterized as relatively slow response and low cost, is used with large capacity for power leveling of slow wind power variation.

(2) EDLC (Electrical Double Layer Capacitor), which has an extremely high response and long life cycle but is high cost, is introduced with small capacity for mitigating fast wind power fluctuation only.

This chapter presents the detailed models of EDLC and battery, together with the related control systems for mitigation of wind power fluctuations. For examining the improving effect by the combined use of these energy storage devices, digital simulations with a typical 66kV class distribution system model integrated by a wind park are conducted, the simulation results have illustrated the validity of the proposed method.

2. An overview of approaches to wind power fluctuation mitigation

Up to date, some approaches have been made to coping with these fluctuation problems caused by wind power integration. The idea of these studies can be simply divided into two types:

- A.** To mitigate the power fluctuation from each single wind turbine generator in a wind park
- B.** To mitigate the fluctuation of total power from a wind park that consists of a group of wind turbine generators

A brief summary of these two methods will be addressed in the following sessions.

2.1. Method Type (A) for mitigation of wind power fluctuation

Method Type (A) aims at mitigating the power fluctuation of each single generator in a wind park and by this way to obtain a stable power output from the whole wind park. The main idea of this method is to develop new type wind turbine generators by application of power electronic technologies, and improve the operation property of the wind turbine generator unit.

At the early stage of wind power development, most of the wind turbine generators are induction machine due to its simple structure, low cost and easily for maintenance; however, there are some problems with this type of generator as well, such as difficulty in control of power output, inrush current and FRT (Fault Ride Through) problems. In order to treat these issues, some approaches have considered using new type of wind turbine generators instead of the induction ones. Typical example of these new type generators is Doubly-Fed Induction Generators (DFIG) or Variable Speed Generators (VSG) [4]-[6]. The basic configuration of DFIG is shown in Fig. 4. By adding a back to back PWM converter to the excitation circuit of the wind turbine generator, the active and reactive power of generator can be dynamically controlled, and hence, a stable power output can be obtained. Another approach is to connect the wind turbine generator to the power grid via an AC-DC-AC circuit (DC

link) [7], since active power of the inverter with DC link can be properly controlled, the wind power penetrating into the grid is possibly stabilized as well. The basic configuration of wind turbine generator with DC link is given in Fig.5. These methods have been verified to be effective in mitigating fast fluctuation and FRT problems [4]~[7].

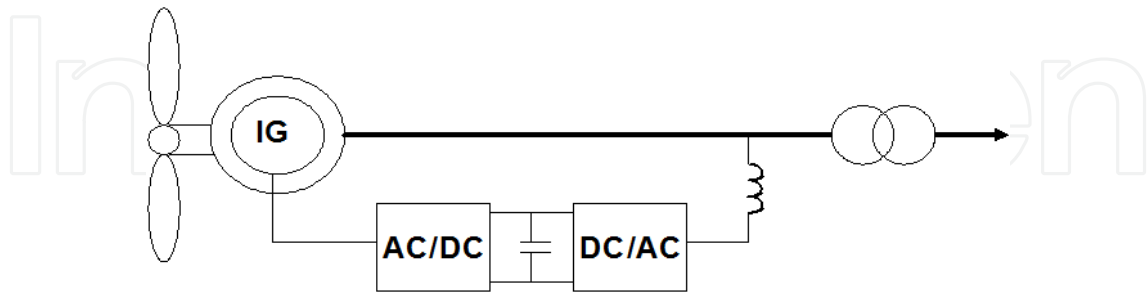

Figure 4. Basic configuration of a Doubly-Fed Induction Generator

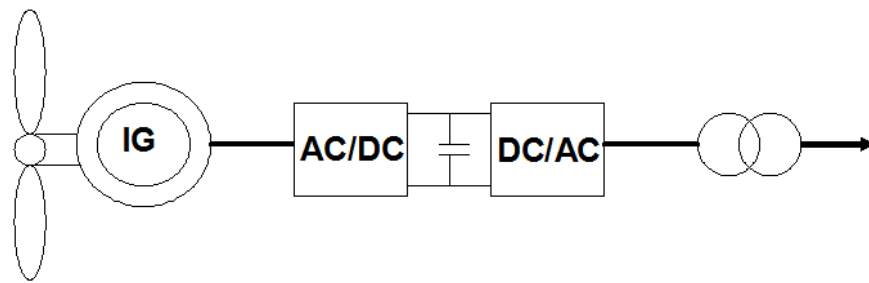

Figure 5. Basic configuration of a wind turbine generator with DC link

Method of Type (A) has the following properties:

- Because each of the generators has the ability to stabilize its own power output, there are not strict limits in the capacity or number of new wind power plants being added to the existing wind park.
- Compared with the conventional induction generators, these improved ones have few in-rush current during starting, and are slightly influenced by the variation of voltage or power at the wind park terminal bus.
- However, due to the necessity of power electronic circuits, these types of generator are normally higher cost than the conventional induction generator, and there is also considerable power loss in these power electronic circuits. In addition, extremely complicated control systems are necessary as well.
- Since there is not energy buffer ability as an energy storage device can provide, even the fast wind power fluctuation can be effectively suppressed by properly control of the power electronic devices, considerable slow fluctuation may still penetrate into the power grid intermittently.

The power fluctuation may aggravate the power quantity or make it difficult for power management. And therefore, wind power integrations are strictly required to satisfy the grid-interconnect guideline.

2.2. Method Type (B) for mitigation of wind power fluctuation

Method Type (B) emphasizes the necessity of stabilizing and managing the total power output from the wind park. The main idea of this method is to control the power flow in the tie transmission line that connecting the wind park to the grid by use of some energy compensation systems such as a battery station, a STATCOM/BESS, a flywheel or SMES (Superconducting Magnetic Energy Storage) system, etc.

The energy storage device is generally installed at the bus near to the tie transmission line, and connected to the bus via a DC/AC inverter. Controls for these energy storages are designed to cancel out the active power fluctuation caused by wind power. Furthermore, power management (large amount of power charge/discharge responding to the power demand or request from the power grid) can be also performed. The basic concept of the method Type (B) is simply illustrated in Fig.6.

The introduction of properly controlled energy storages are confirmed to be able to effectively compensate most of the slow wind power fluctuation and reduce negative impacts on the existing power grid [8]-[15], in addition with the ability to bring about economic benefits by power management [16].

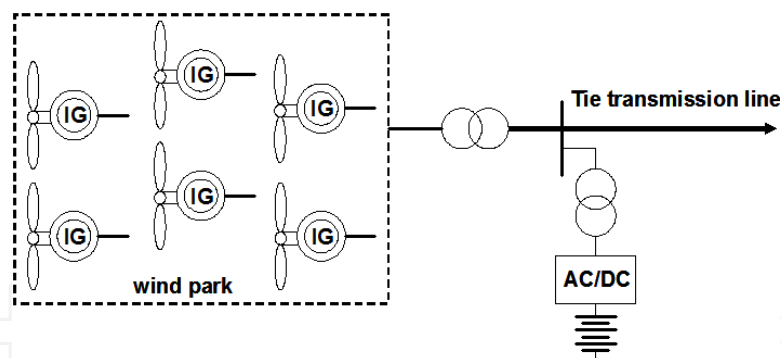

Figure 6. Basic concept of method Type (B) for mitigation of wind power fluctuation

Method Type (B) has the following properties:

- Only limited number of energy storage stations is necessary. It is space-saving and can be built compactly.
- Large capacity of power energy can be saved or released. Hence, the energy storage station can be employed not only as a method to compensate the slow wind power fluctuation that is accompanied with large change of power energy, but also as a meaning to support the power demand-supply regulation (charge or discharge at required time duration) in the grid.

- Since the power flowing out the wind park can be stabilized, it is unnecessary to mitigate the power output for every single wind generator in the wind park, and therefore, most of the generators can possibly use the low cost induction machines.
- However, in case that some new wind turbine generators are to be added to the existing wind park, the necessary capacity of energy storage may change and it is considered not an easy work to vary the capacity of an existing energy storage station.
- Beside, the high cost of energy storage devices is also a big issue. Presently, some new energy storage devices of low cost, high efficiency and high energy density are under development.

3. An overview of energy storages application for wind power systems

In the recent year, along with the increasing utilization of renewable energy sources and the remarkable advance in smart grid technology, the energy storage is considered as one of the key devices in the next generation power networks. Among the art-of-energy storage, beside the material and production technologies, the important issues of energy storage application in power systems are considered as the followings:

- Design of control systems for mitigation of power fluctuation and power management
- Determination of adequate capacity of energy storage devices and power converters
- Identification of proper location of energy storage stations in a power grid

Up to date, many studies have been done related to the application of energy storages. The works in (8) - (10) discussed the design of control systems and the determination of optimal capacity of battery energy storages for the purpose of wind power stabilization, and have illustrated the improving effect by introduction of batteries in a wind park. Reference (11) - (13) presented an approach to the application of EDLC (Electric Double Layer Capacitor, referred to as Super-Capacitor as well) in a wind power system. The results from these works have shown the effectiveness of EDLC for mitigation of extremely fast wind power fluctuation. Paper (14) studied the wind power stability improved by a SMES (Superconducting Magnetic Energy Storage) system. Reference (15) advocated the combined use of EDLC and battery for suppressing both the fast and slow wind power fluctuation, and (16) investigated the operation and sizing of energy storage in terms of economic benefits in the power market.

4. Why combined use of energy storages is necessary for a wind power system?

Large-scale wind parks may be built on plains, offshore and in mountainous regions. For wind parks located offshore or on plains where stable, strong wind conditions are available, fast fluctuation of wind power may not be a serious problem since in these cases, naturally

few fast power fluctuations occur, furthermore, such fluctuations are smoothed by the power leveling effect with different wind turbine generators distributed over a broad area. If these wind parks do not directly supply power to local loads or are not be interconnected to an extremely weak power grid, energy storage is even unnecessary.

However, in case of wind parks constructed in complicated topographical mountainous regions where good wind conditions can hardly be obtained, significant and frequent changes of wind speed and wind direction may occur, and both extremely fast fluctuations and slow variations appear with wind power output, energy storage thus be necessary for dealing with the problems caused by these fluctuations. Furthermore, if only a secondary electrical battery is used, the slow response of battery make it hardly compensate the extremely fast power fluctuation, and in addition, the battery may possibly charge or discharge frequently responding to both the fast and slow changes of wind power, resulting in significant shortening of its service time. In such case, the combined use of an EDLC and a battery is considered to be an effective choice.

5. The idea of combined use of different types of energy storages for a wind power system

The idea of combined use of EDLC and battery in a wind park is classified to the method of Type (B) in section 2. It aims at obtaining both mitigation effects of fast power fluctuation and power leveling effect of slow power variation in the tie transmission line, and in the meantime, avoiding frequent charge/discharge operation of battery. The basic concept of a wind park with combined use of EDLC and battery is shown in Fig.7.

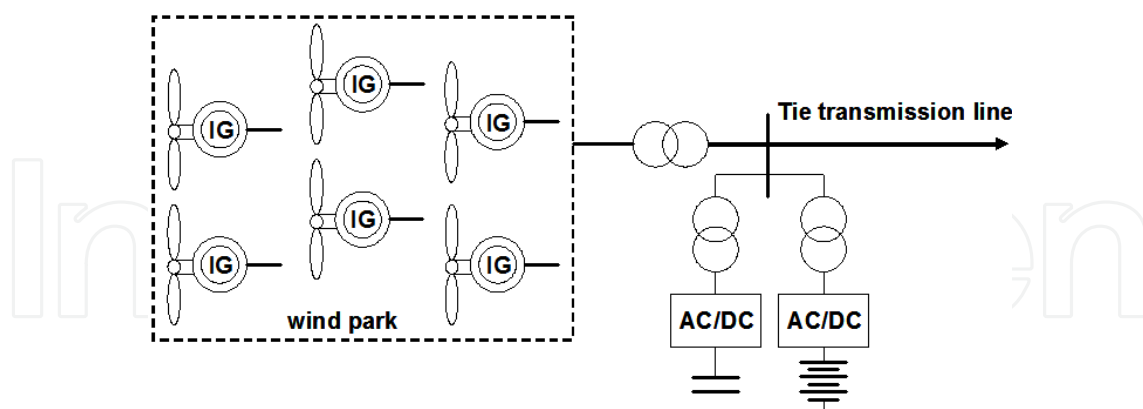

Figure 7. Basic concept of a wind park with combined use of EDLC and battery

Taking consideration of the facts that EDLC has extremely high response, long life cycle but with low energy density and high cost, whereas battery is relatively low cost but with slow response and short life cycle, EDLC is employed as a manner to mitigate the fast fluctuations in a small capacity, and battery is used as the one to deal with the slow variation with large capacity.

6. Introduction and analysis model of EDLC

6.1. About EDLC

EDLC is a newly developed electrical storage device which has recently attracted great attentions. This is kind of electro-chemical capacitor that has large energy storage capacity, and therefore often called a super- or ultra-capacitor. Since EDLC has several advantages such as an extremely long life-cycle, no contamination, operation under normal temperature and extremely rapid charge/discharge operation from 0% to full capacity with less voltage loss, it is considered suitable for use in the case when frequent charge/discharge is necessary. Nevertheless, it also has disadvantages such as low energy density and high cost, and thus, it is not preferable to use EDLC as a manner for large-capacity energy storage.

EDLC modules with capacities from several to several thousands Farads are already commercially available. For power energy storage such as that used in this study, an EDLC bank needs to be made by means of connecting several hundreds of EDLC cell units in parallel and in series.

6.2. Analysis model of EDLC

Since the EDLC is a newly developed device and still under study, there is no ready-made model for conducting simulations. In this work, an analysis model of EDLC is derived based on an equivalent circuit presented in reference [17].

Electrical characteristic expression of EDLC can be basically expressed in the form of

$$V_s(s) = I_s(s) \cdot f(s) + Q_{C0} \cdot g(s) \quad (1)$$

Where, $V_s(s)$ is the DC voltage, $I_s(s)$ is the DC current and Q_{C0} is the initial charged capacity of the EDLC; $f(s)$ and $g(s)$ are transfer functions from $I_s(s)$ to $V_s(s)$ and that from Q_{C0} to $V_s(s)$, respectively.

In expression (1), $f(s)$ and $g(s)$ need to be derived. According to the work in [17], an EDLC bank can be electrically expressed by an equivalent circuit as shown in Fig.8, which takes the allotment of internal resistance, leak resistance and capacitance of an EDLC unit into account and is referred to as "Double-Layer Equivalent Circuit." In Fig.8, R_s and R_p are internal resistance, and R_L is leakage resistance. C_1 and C_2 are equivalent electrostatic capacitances, respectively.

Based on Fig.8 and applying electrical circuit theory, the electrical characteristic of EDLC can be obtained as expression (2).

$$\begin{aligned}
 V_s(s) = I_s(s) & \left\{ \frac{C_2 R_p R_L s + R_L}{C_1 C_2 R_p R_L s^2 + (C_1 R_L + C_2 R_L + C_2 R_p) s + 1} + R_s \right\} \\
 & + \frac{C_2 R_p R_L s + R_L}{C_1 C_2 R_p R_L s^2 + (C_1 R_L + C_2 R_L + C_2 R_p) s + 1} Q_{10} \\
 & + \frac{R_L}{C_1 C_2 R_p s^2 + (C_1 + C_2 R_L + C_2 R_p) s + 1} Q_{20}
 \end{aligned} \tag{2}$$

Herein, Q_{10} and Q_{20} represent the initial charged capacities of C_1 and C_2 in Fig.8.

Expression (2) gives the electrical characteristics of the DC voltage V_s responding to the change of DC current I_s and can be used as an analysis model of EDLC for simulation study.

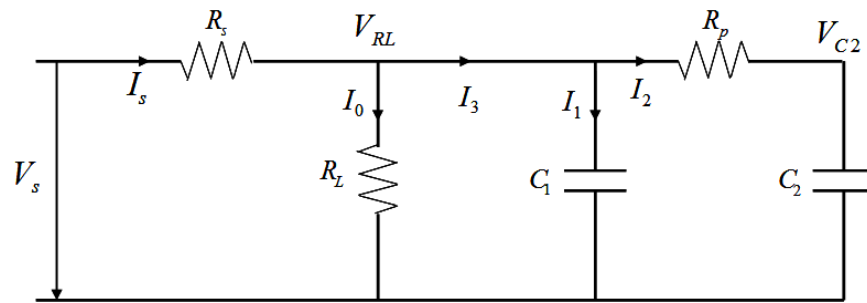

Figure 8. Double-layer equivalent circuit model for EDLC bank

7. Introduction and analysis model of battery

7.1. About battery

Batteries are the most widely used energy storage devices. At present, several types of secondary electrical batteries have been developed or are under development. Among these batteries, the nickel-metal hydride battery and the lithium-ion battery are popular types for consumer electronics (portable electronics with small capacity) and are still under development. The sodium-sulfur (NaS) battery is a new type of molten metal battery and primarily suitable for large-scale non-mobile applications. And the lead acid battery charges/discharges by utilization of chemical reaction with the metallic lead soaked in a solution of diluted sulphuric acid. Being fabricated from inexpensive materials, it is of relatively low cost. In addition, it can operate in normal temperature. Given these advantages, this type of battery is already widely used in various fields and mass-production technology has been completely established. Furthermore, its operational characteristics have been fully elucidated. For this reason, a lead acid battery was selected for large-scale energy storage in this study. However, because the dynamics of this type of battery are governed by chemical reactions, its response is not as quick and its cycle life is not as long as those of an EDLC. For this rea-

son, the lead acid battery is considered to be suitable to deal with slow wind power fluctuation with relatively large capacity so as to reduce the usage of the high-cost EDLC.

For obtaining large capacity, the battery bank consists of large quantity of cell units connecting in parallel and in series.

7.2. Analysis model of battery

An equivalent circuit of Fig.9 is used for deriving the analysis model of battery [18].

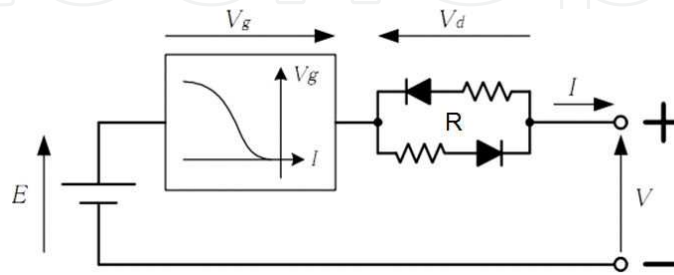

Figure 9. Equivalent circuit model of lead acid battery

According to Fig. 9, the terminal voltage V of the battery can be calculated by

$$V = E - V_d + V_g \tag{3}$$

Where, E is the equivalent electromotive force, V_d is the voltage loss in circuit resistance R, and V_g is the additional voltage increase at time toward the end of charge. These variables are calculated by the following expressions:

$$E = E_0 - \Delta E(1 - SOC) \tag{4}$$

$$V_d = RI + V_a(1 - e^{-\frac{|I|}{K_a}}) \tag{5}$$

$$V_g = \begin{cases} 0 & \text{during discharge} \\ \frac{V_{g\max}}{2} e^{\frac{SOC - SOC_g}{K_g |I|}} & \text{while } SOC < SOC_g \text{ during charge} \\ \frac{V_{g\max}}{2} (2 - e^{\frac{SOC - SOC_g}{K_g |I|}}) & \text{while } SOC \geq SOC_g \text{ during charge} \end{cases} \tag{6}$$

Herein, SOC is the state of capacity, E_0 is the value of E in the fully charged condition, ΔE is the change of E responding to SOC, V_a is the maximum value of the nonlinear component of V_d , $V_{g\max}$ is the maximum value of V_g and SOC_g is the capacity where the additional voltage starts to increase during the charge, and K_a and K_g are coefficients.

Expression (3) – (6) can be used as an analysis model of battery for simulation study.

8. Charge and discharge strategy for energy storages

EDLC may physically charge and discharge to its full capacity, however, whereas working with a DC/AC inverter for connecting to the AC power grid, extremely low DC voltage may lead to malfunctioning of the inverter. On the other hand, discharge of the battery to the level under half of its capacity may significantly shorten its life cycle. For this reason, a low limit for DC voltage of EDLC and battery bank is considered to ensure that DC voltage does not decrease to an extremely low level during its discharge process. On the other hand, DC voltage must not extend beyond the rated voltage value of the energy storage device so as to protect it from being destroyed. Thus, an upper limit for DC voltage is necessary as well.

This process is obtained by the follow strategy:

- During the process in discharge mode, while DC voltage reaches a low limit, discharge is stopped automatically and energy storage device automatically switches to the charge mode.
- During the process in charge mode, while DC voltage approaches an upper limit, charge is stopped automatically and the energy storage device is ready to discharge.
- In this study, the low limit and upper limit were set to be 0.5 p.u. and 0.9 p.u., respectively.

Furthermore, in order to avoid the phenomenon that discharge or charge operation is repeated around the limit boundary, the following requirement is added in the charge/discharge control:

- Whenever the EDLC changes its charge or discharge mode, this mode must be continued until the DC voltage reaches 0.7 p.u.

Based on the above control strategy, the flow chart of the EDLC charge/discharge control as depicted in Fig.10 is proposed.

9. Wind power generation system model with introduction of combined use of energy storages

In this chapter, in order to examine the validity of the combined use of EDLC and battery energy storages, a typical wind power system model shown in Fig. 11 is created for conducting simulation study. In this model, the wind park is assumed to have a total capacity of 30 MW and is simulated by three induction generators, each of which has a capacity of 10 MW representing equivalently a cluster of wind turbines generators (e.g., 4 generators of 2.5 MW class) connected to a 22 kV bus. Generated power from the wind park is supplied to local

loads and the remaining portion is sent to the infinite bus (bulk system) through tie transmission line 3.

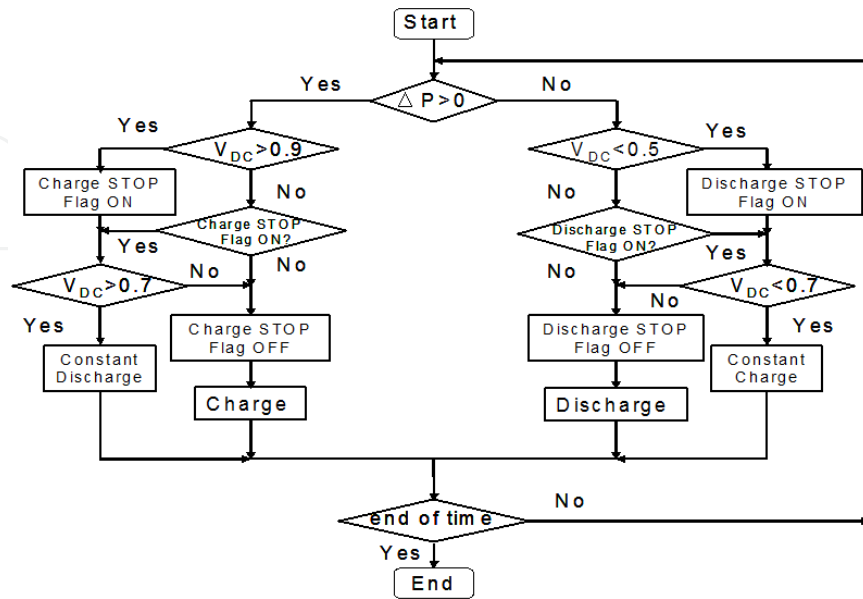

Figure 10. Flowchart of charge/discharge control for EDLC and battery

EDLC and battery energy storage systems are introduced at the substation in Bus 4 between the tie line and the wind park. Both of these energy storage systems are connected to Bus 4 via a DC/AC inverter with a capacity of 5.0 MW.

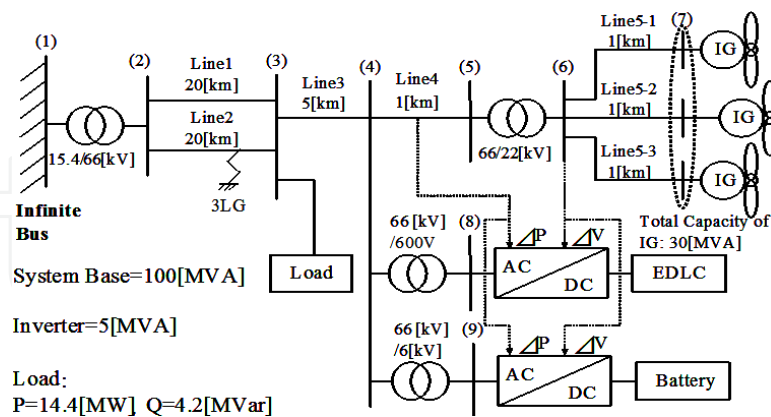

Figure 11. Wind power system model with combines use of EDLC and battery

The simulation study was completed by use of a power system analysis software package named “MidFielder,” which is developed by TEPCO (Tokyo Electric Power Co., Japan). Transmission line and transformer model used the default ones with parameters prepared by the software package, which is created based on the real data of power network in Japan.

9.1. Wind Turbine Generator Model

Taking introduction costs of the wind park into account, all of the wind turbine generators are assumed to be low-cost induction generators. The induction generator model used the standard model with parameters prepared by the software package, which are listed in Table 1.

9.2. Parameters of EDLC and battery

Parameters of the EDLC bank and the battery bank which appear in Fig.8 and Fig.9 are tabulated in Table 2 and Table 3, respectively. Comparing the capacity of the EDLC and battery in these tables, it is obviously seen that the capacity of the battery is considerably larger than that of the EDLC. Working with these capacities, the EDLC can continue charge/discharge at time duration of 20 sec. with inverter outputting in full capacity, and the battery extends the time to 6 hours (assuming 50% of capacity can be used for energy storage).

Constants	Values
Pole Number	4
Stator resistance (p.u.)	0.002
Stator leakage reactance (p.u.)	0.11
Rotor resistance (p.u.)	0.013
Rotor leakage reactance (p.u.)	0.12
Excitation reactance (p.u.)	3.9
Inertia constant (s)	1.5
Rated slip	0.012

Table 1. Parameters of induction generators

Parameters	Values	Parameters	Values
Capacity[MJ]	388.8	R_s [m Ω]	0.089
C_1 [F]	1512	R_p [m Ω]	0.837
C_2 [F]	648	R_l [k Ω]	3.934

Table 2. Parameters of EDLC bank

9.3. Inverter model and control systems

A DC/AC inverter is necessary for connecting the EDLC and battery bank to the AC power grid. The inverter model in this simulation study used the standard one prepared by the software package, which is an ideal inverter model ignoring power loss and represents its electrical characteristics by use of analysis models including a conversion transformer mod-

el, a 6-bridge inverter circuit model, a PLL model, a 3 phase–dq transformation model and a current control PWM model.

Parameters	At Charge	At Discharge
Capacity	2000Ah(2.16x10 ⁵ MJ)	
E ₀ [kV]	6.621	6.423
ΔE[kV]	0.726	0.645
V _{gmax} [kV]	1.236	-
R[mΩ]	0.863	0.261
K _a	213.143	213.143
K _g	0.0003	-

Table 3. Parameters of Battery bank

The active power and reactive power output from the inverter model can be controlled. Active power output is controlled by I_{dinv} (AC current in d axis of coordinates) and reactive power is outputted responding to I_{qinv} (AC current in q axis of coordinates). The control for I_{dinv} and I_{qinv} is designed in this study. The control block for DC/AC inverter connected to the EDLC is shown in Fig. 12 and that for the battery is given in Fig.13.

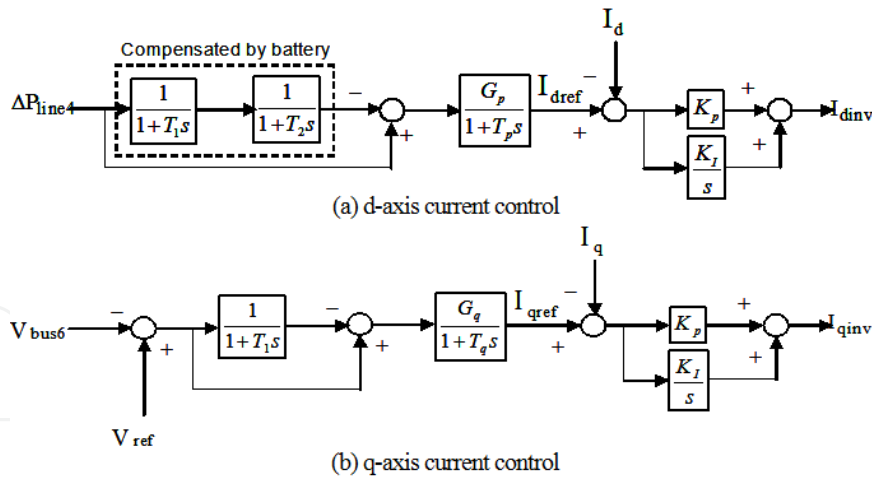

Figure 12. Control blocks for EDLC inverter

In Fig.12 and Fig.13, ΔP_{line4} is the deviation of active power in transmission line 4; V_{bus6} and V_{ref} are the measured and reference value of Bus 6 voltage, respectively; and I_d and I_q are measured AC current in d-q axis of coordinates. Control parameters in these control blocks are set as follows:

$$G_p=20, G_q=66, K_p=0.4, K_i=10, \text{ and } T_p=T_q=0.04[\text{sec}], T_1= 2.0[\text{sec}], T_2=5.0[\text{sec}]$$

It can be known from these control blocks that in order to level the power flow in tie transmission line 3, so as that the power fluctuation from wind park does not affect the local load and bulk system, the deviation of power in line 4 (the transmission line between the wind park and the tie transmission line 3) is used to control the active power output of the EDLC and battery; Meanwhile, in order to mitigate the voltage fluctuation in Bus 4 where the wind park is integrated into the distribution system, voltage deviation of wind park terminal Bus 6 is adopted as a control signal to control reactive power from these energy storage devices.

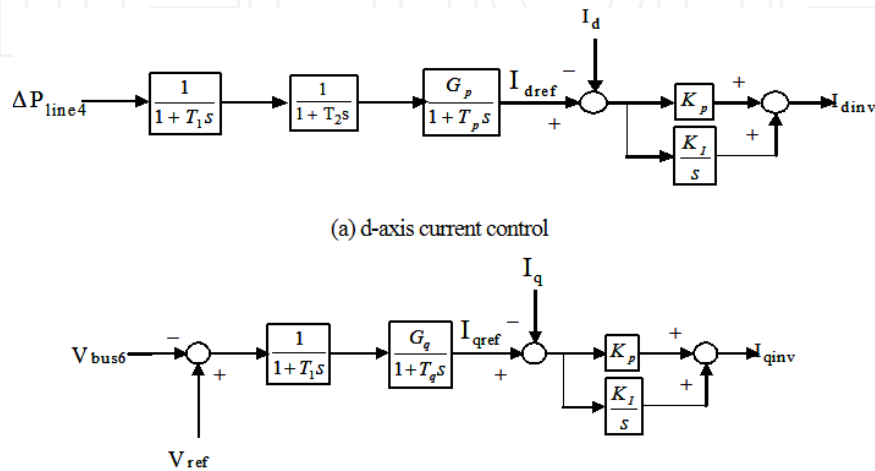

Figure 13. Control blocks for battery inverter

These control systems are designed to control the inverter output cooperatively. The cooperative control strategy depicted in Fig.12 and Fig.13 is explained in the following.

- (a) The deviation of active power of line 4 is calculated and used as the control signal for I_d current so that the active power output from energy storage devices can cancel out the power variation of line 4 and thus level the active power flowing into tie transmission line 3.
- (b) Voltage deviation of Bus 6 is used to control I_q current so as that these energy storage devices can output adequate reactive power to suppress the voltage deviation of Bus 6 from its reference.
- (c) Slow power variation is compensated for by the battery, and this is realized by adding low-pass filters with a time constant of T_1 to the control block for the battery. Meanwhile, the fast fluctuation is mitigated by the EDLC, which is calculated by excluding the compensated portion by battery from the input signal.

10. Simulation studies

10.1. Wind speed data

For simulation study, wind speed data given in Fig.14 are modified based on the actual wind velocity data measured with an anemometer at the campus of Tohoku Gakuin Univer-

sity, Japan. In this study, wind data of 1000 seconds measured with time-interval of 1.0 second are selected for simulation.

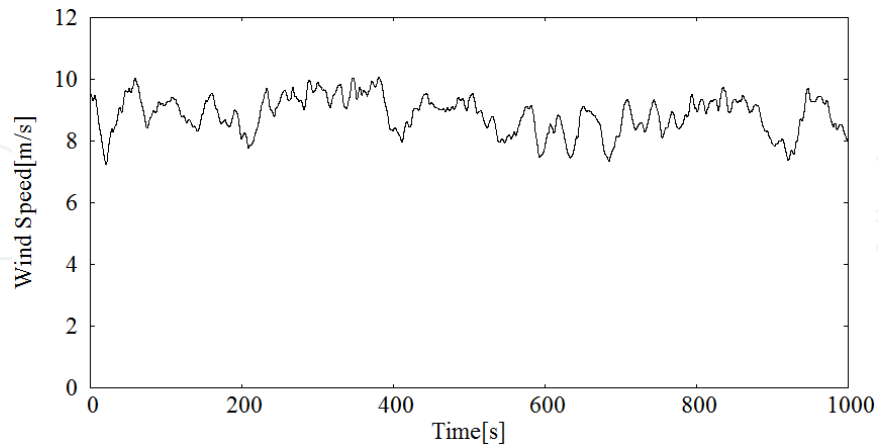

Figure 14. Wind speed data

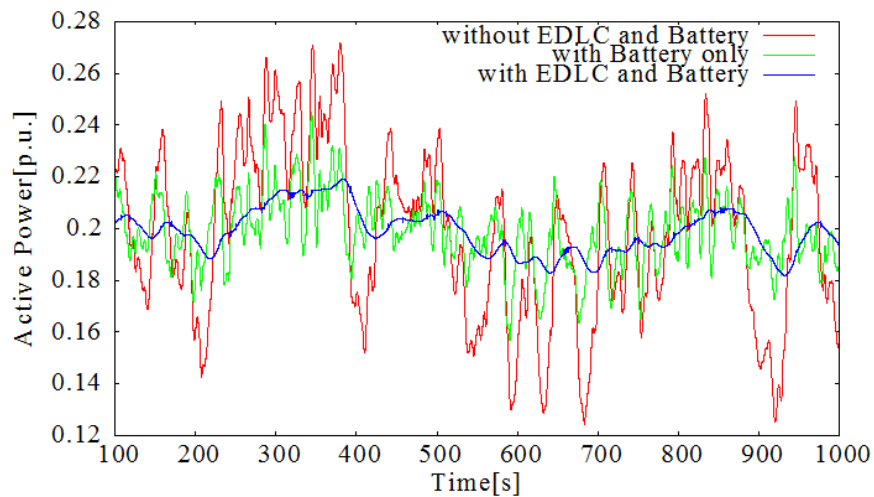

Figure 15. Active power of tie transmission line 3

10.2. Simulation results and comments

Based on the above-mentioned simulation conditions, simulation studies were conducted to verify the following properties:

- Mitigation effect of fast and slow fluctuations of power flow in tie transmission line 3
- Enhancement effect of voltage stability of Bus 4 where the wind park is integrated into the distribution grid
- Verification of FRT capability

Mitigation effect of power flow in tie transmission line

With the wind turbine generators driven by the fluctuating wind speed in Fig.14, the power flow in tie transmission line 3 in cases of “without energy storage,” “with battery only” and “with both EDLC and battery” are shown in Fig.15, and the active power output from the EDLC and battery are given in Fig. 16.

Comparing the change of active power curves in Fig.15, it can be seen that the active power of tie line 3 fluctuates considerably in the case without any energy storage devices, whereas in the case with only a battery, although slow variation of power flow is compensated, some fast fluctuation still appears. This result indicates that the slow response of the battery result in its difficulty to trace and absorb the extremely fast fluctuation. In contrast, it can be verified that in the case with both the EDLC and battery, power flow is effectively suppressed and leveled.

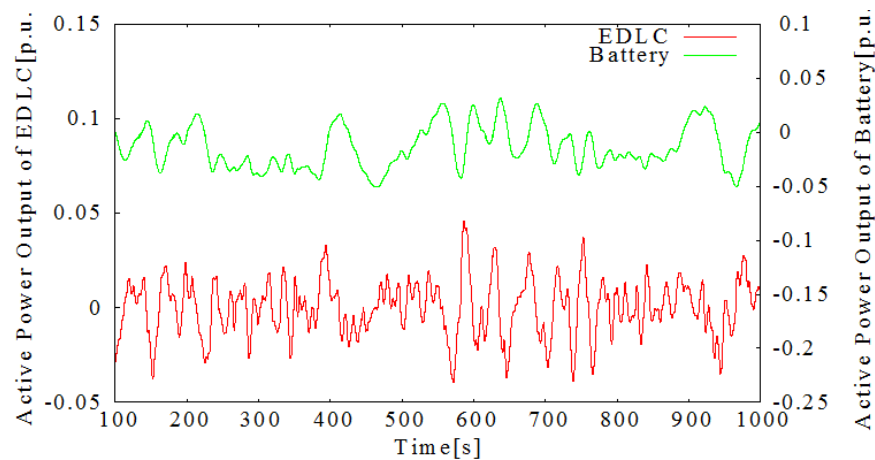

Figure 16. Active power output from EDLC and battery

From Fig.16, it can be confirmed that the active power from the EDLC is significantly changing so as to mitigate the fast fluctuation and that meanwhile, the power from the battery is slowly changing to compensate for the slow variation of the power flow.

Enhancement of bus voltage stability

Under the same simulation conditions, the wave curve of the terminal voltage of Bus 4, where wind power is integrated into the distribution system, is shown in Fig. 17. From Fig. 17, it can be seen that the voltage of Bus 4 fluctuates significantly from 0.9 [p.u.] to 0.984 [p.u.] if without any compensation method, whereas in cases with only the battery and with the EDLC and battery, the voltage is compensated to 0.995-1.002 [p.u.]. Furthermore, it is also known that even with only the battery, the voltage stability is enhanced remarkably, and the improving effect by the EDLC is not obviously observed.

The reactive power output from battery and EDLC system are given in Fig. 18. It can be known from this result that reactive power of the battery is obviously larger than that of the EDLC, which means that voltage variation is mainly compensated by the battery. In addition, rapid reactive power change of EDLC is observed due to the fast voltage fluctuation of

Bus 6 (wind park terminal bus). However, unlike the active power flow in the tie transmission line 3 in Fig. 15, which is directly affected by the active power from the wind park, the voltage of Bus 4 is influenced indirectly by the voltage of wind park terminal Bus 6. For this reason, although the EDLC can bring about a mitigation effect of fast voltage fluctuation in the voltage of Bus 6, this enhancement effect is not remarkably revealed in the voltage curve of Bus 4. This result also indicates that if only voltage stability enhancement in the interconnection bus 4 is required and the voltage feature of Bus 6 is considered being not significantly important, it is sufficient to add voltage compensation function only to the battery and EDLC devices may not be mandatory for this purpose.

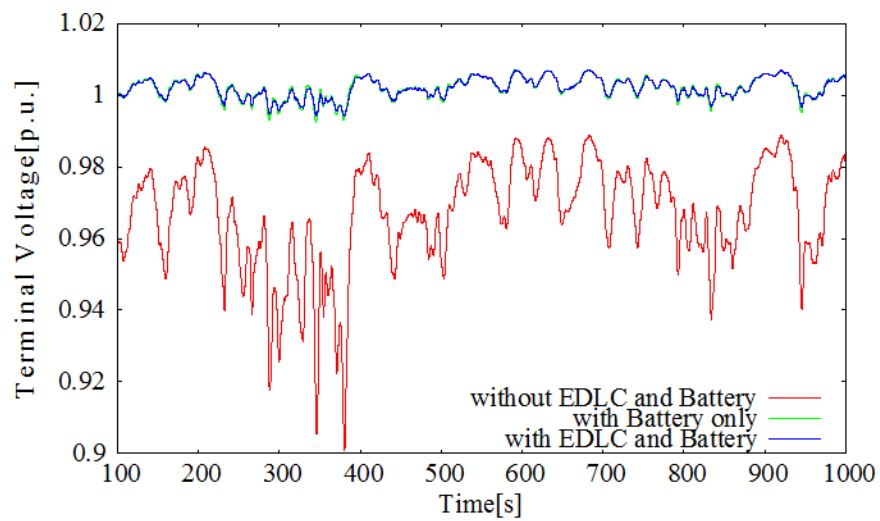

Figure 17. Voltage of bus 4 (the bus where wind park is interconnected to the distribution grid)

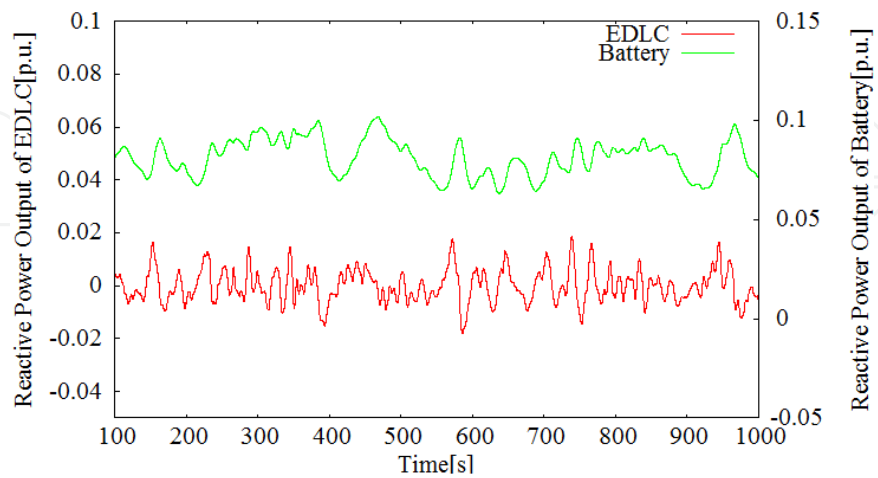

Figure 18. Reactive power output from battery and EDLC

Verification of FRT (Fault Ride Through) capability

Under the same simulation conditions and assuming that a 3LG fault (100 ms) occurs at 225 second at line 2 (near bus 3), the simulation result of wind park terminal voltage of Bus 6 is shown in Fig. 19. From this figure, it is known that in the case without any energy storage, because the dramatic decrease in bus voltage occurs along with the fault and without any voltage support, bus voltage can not recover after the fault, and wind turbine generators have to be tripped from the power grid to avoid accelerated step out. On the other hand, because the energy storage devices can supply reactive power simultaneously following the fault and facilitate the recovery of bus voltage, the introduction of the EDLC and battery leads to the rapid recovery of bus voltage after the fault, and wind turbine generators can continue operation. This is usually referred to as the FRT capability.

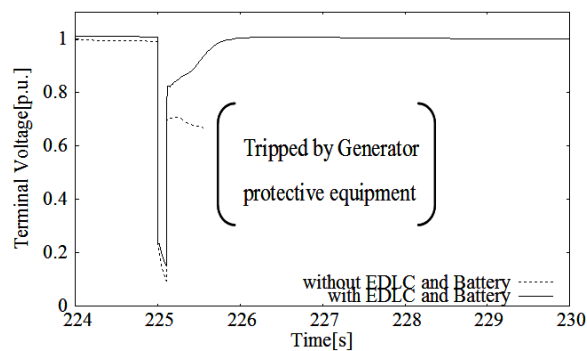

Figure 19. Voltage of Bus 6 (terminal bus of wind park)

11. Conclusions

In the recent year, along with the increasing concerns of global warming and exhaustion problem of fossil energy resources, sustainable power generations such as wind power and photovoltaic power etc. have been increasingly integrated into the existing power grids. However, some challenging issues associated with the fluctuation and unpredictability in renewable power generation have to be adequately treated so as to facilitate its further development in the future power networks. This chapter has presented one of the technologies for construction of a wind park with application of energy storages.

This chapter has given an overview of the current technologies for an improved wind power system, and then presented a simulation-based approach to dealing with the fluctuation problems in terms of power flow and voltage stabilizations, which is caused by wind power integration into a distribution system. And a method that takes consideration of combined use of energy storage devices with different response characteristics and costs was proposed and verified.

The concepts of this chapter are summarized in the following:

- For the purpose of mitigating the power fluctuation due to wind power generation, up to data, technologies applied to a single wind turbine generator such as DFIG or DC link

was studied and some of these technologies have been already in practical use; on the other hand, technologies considering the total operation of a wind park such as utilization of centralized energy storages station is noticeably developed as well.

- From the point of view of wind power stabilization and power management, the energy storage is considered to be an extremely important technology for the stable operation of wind parks especially that are integrated to relatively weak distribution systems.
- The combined use of EDLC and battery is an advisable way for obtaining a satisfactory improved effect of power flow leveling and voltage stability for a wind power system, especially which located in complicated topographical conditions (e.g. the mountainous regions) where good wind conditions can hardly be obtained and with both fast and slow fluctuations in wind speed.
- In the combined energy storage system, a battery can be used in large capacity for leveling long-term power flow variation and an EDLC can be used to mitigate the short-term fluctuation with a relatively small capacity.

Author details

Guohong Wu^{1*}, Yutaka Yoshida¹ and Tamotsu Minakawa²

*Address all correspondence to:

1 Dept. of Electrical of Electrical Engineering & Information Technology Tohoku Gakuin University, Japan

2 NPO ECA, Japan

References

- [1] Technical Report of Japan Society for the Promotion of Science Research for the Future Program:.. (2002). "Highly Efficient Use of Energy and Reduction of its Environmental Impact", 22-23.
- [2] GWEC, "Global Wind 2010 Report". (2011). Global Wind Energy Council, April.
- [3] Ernst, B., Wan, Y. H., & Kirby, B. (1999). "Short-Term Power Fluctuation of Wind Turbines: Analyzing Data from the German 250-MW Measurement Program from the Ancillary Services Viewpoint". *Proc. Windpower '99 Conference, Burlington, Vermont, USA, June*.
- [4] Pena, R., Clare, J. C., & Asher, G. M. (May 1996). "Doubly fed induction generator using back-to-back PWM converters and its application to variable-speed wind-energy generation". *IEE Proc. Electric Power Applications*, 143, 231-241.

- [5] Muller, S., Deicke, M., & De Doncker, R. W. (Jun.2002). "Doubly fed induction generator systems for wind turbines". *IEEE Trans. Industry Applications*, 8, 26-33.
- [6] Datta, R., & Ranganathan, V. T. (Sept. 2002). "Variable-speed wind power generation using doubly fed wound rotor induction machine - a comparison with alternative schemes". *IEEE Trans. Energy Conversion*, 17, 414-421.
- [7] Song, S.H., Kang, S.i., & Hahm, N.k. (2003). "Implementation and control of grid connected AC-DC-AC power converter for variable speed wind energy conversion system". *Proc.Applied Power Electronics Conference and Exposition*, 1, 154-158.
- [8] Teleke, S., Baran, M.E., Bhattacharya, S., & Huang, A.Q. "Optimal Control of Battery Energy Storage for Wind Farm Dispatching". *IEEE Trans. Energy Conversion*, 25, 787-794.
- [9] Black, M., & Strbac, G. "Value of Bulk Energy Storage for Managing Wind Power Fluctuations". *IEEE Trans. Energy Conversion*, 22, 197-205.
- [10] Nanahara, T. (2009). Capacity Requirement for Battery Installed at a Wind Farm. *IEEJ Trans. on Power and Energy*, 129(5), 645-652.
- [11] Kinjo, T., Senjyu, T., Urasak, N., & Fujita, H. "Output levelling of renewable energy by electric double-layer capacitor applied for energy storage system", *IEEE Trans. Energy Conversion*, 21, 221-227.
- [12] Abbey, C., & Joos, G. (2007). "Supercapacitor Energy Storage for Wind Energy Applications", *IEEE Trans. Industry Applications*, 43, 769-776.
- [13] Goto, M., Wu, G., Tada, Y., & Minakawa, T. (2007). "The Basic Study of Influence of Energy Storage Systems on WindPower Generation Systems", *IEEJ Trans. Power and Energy*, 127(5), 637-644.
- [14] Nomura, S., Ohata, Y., Hagita, T., Tsutsui, H., Tsuji, S., & Shimada, R. (2005). "Wind farms linked by SMES systems", *IEEE Trans. Applied Superconductivity*, 15, 1951-1954.
- [15] Yoshida, Y., Wu, G., & Minakawa, T. "Mitigating Fluctuation of Wind Turbine Power Generation System by Introduction of Electrical Energy Storage with Combined Use of EDLC and Lead Acid Storage Battery", *Proc.POWERCON2010, HangZhou, China*, (FP0689).
- [16] Korpaasa, M., Holena, A. T., & Hildrum, R. (2003). "Operation and sizing of energy storage for wind power plants in a market system", *Journal of Electrical Power and Energy Systems*, vol.25, 599-606.
- [17] Okamura, M. (2000). Electric Double Layer Capacitor and Energy Storage System, *Nikkan Industrial Publication Corp.*
- [18] Shimada, T., Kurokawa, K., & Yoshioka, T. "Highly Accurate Simulation Model of Battery Characteristics". *Conf. Rec. IEEJ Annual Meeting*, 7, 48-49.

IntechOpen

IntechOpen