

We are IntechOpen, the world's leading publisher of Open Access books Built by scientists, for scientists

4,800

Open access books available

122,000

International authors and editors

135M

Downloads

Our authors are among the

154

Countries delivered to

TOP 1%

most cited scientists

12.2%

Contributors from top 500 universities



WEB OF SCIENCE™

Selection of our books indexed in the Book Citation Index
in Web of Science™ Core Collection (BKCI)

Interested in publishing with us?
Contact book.department@intechopen.com

Numbers displayed above are based on latest data collected.
For more information visit www.intechopen.com



E-Learning in Chemical Education

Ana Maria Josceanu, Raluca Daniela Isopescu, Paula Postelnicescu,
Anca Madalina Dumitrescu and Razvan Onofrei

Additional information is available at the end of the chapter

<http://dx.doi.org/10.5772/50292>

1. Introduction

Continuous efforts are devoted to fulfil locally the European and national policies in developing a higher education system supported by information and communications technology (ICT). In Romania, the development of infrastructure, communications, and information systems and services has been very rapid because it represents a crucial condition for general economic and social development (figures 1 and 2).

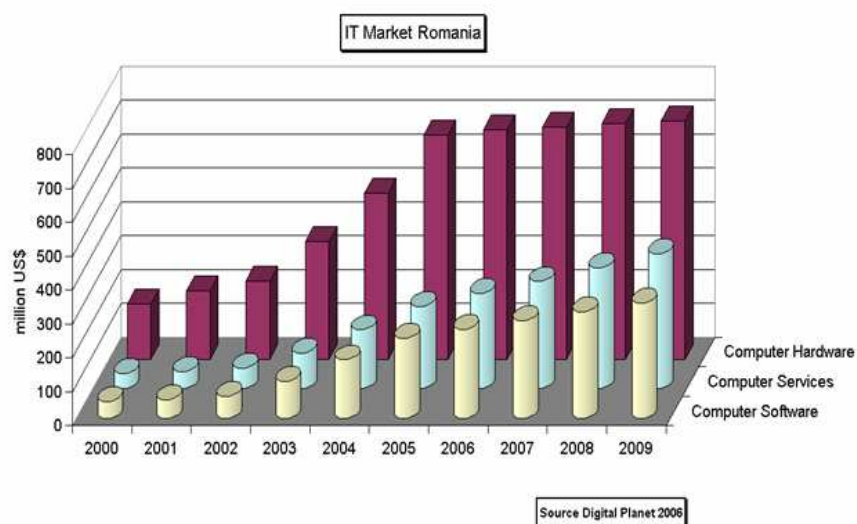

Figure 1. High rate of all IT sectors in Romania 2000-2009 [1]

It is known that Romania has had an impressive ICT experience, being the first Eastern European country to build computers: CIFA-1957, MECIPT-1961, and DACICC-1962 [1]. Nowadays, ICT is not anymore a product or service for elites, and it is considered that “Information Society is for all”.

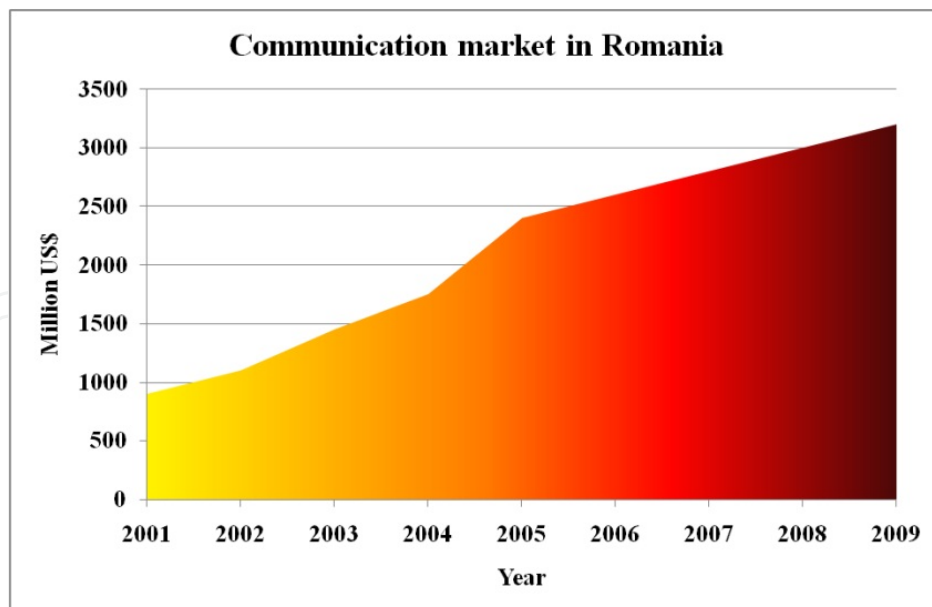

Figure 2. Development of the communication market in Romania 2000-2009 [1]

ICT revolution has a significant impact on all kinds of human activities. Educational and training activities are no exception. Rather, it could be said that the impact on them is larger, and the ICT-assisted education may become a personalized and adaptive experience.

Learning nowadays is a continuous and active process, performed with a specified goal and applied to real life situations. In the past, the main criteria in selecting a higher education institution were connected to its prestige and location. In Romania, characterised by a relatively low life standard, the location criterion was an important one for potential students. On the other hand, the prestige criterion brought many foreign students to Romanian universities. Globalisation tends to amplify both criteria. Thus, a true education market, governed by rules identical to any other services market, has been created. As a consequence, many high prestige academic institutions have found themselves in the situation of losing some of their students in favour to other institutions, located at larger distances, but better anchored in the education market.

Higher education in Romania has been undergoing major changes, in order to achieve the highest possible compliance degree to the Bologna declaration and the 'communiqué' adopted by the Ministers of Higher Education of the Bologna Signatory States gathered in Bergen, in 2005. The challenges and priorities identified then have been associated to the link between higher education and research, social dimensions of higher level training, mobility, and attractiveness of European Higher Education Area. The legal framework has already been established in Romania in 2005. Since then, the educational path consists of a 3 / 4 years bachelor, a 2 years master, and hopefully a 3 years Ph. D degree. The Romanian academic education has been also enriched with post-doctoral fellowships.

Today students have a much wider view of the world than their parents, can juggle several cognitive tasks at the same time, are more relativistic and tolerant, and approach new situations and problems as a challenge. They also present a more fragmented sense of time,

reduced attention span, and considerable lack of faith in institutions and explanatory narratives, reduced sense of place, community, and history, and reduced vision for a personal or collective future. On the other hand, academics face particular challenges raised by the special Bologna requirements and the role played by the teacher in the ICT era [2-4].

The ICT-based education contributes to the development of a well established set of European approved skills using the 'learning by doing' approach, and it offers flexible lectures design and virtual practice lab, and simulation environments. ITC technology should become a productivity tool – "more, better, faster."

The new engineering curriculum, adapted to Bologna Convention requirements, implies a more student-oriented teaching system, with stepwise knowledge achievements for graduate and postgraduate degrees. A systematic attention should be directed towards the teaching and learning processes for engineering degrees. Even though a variety of innovative teaching techniques are available to engineering instructors, the education of engineers in many universities still follows the traditional lecture format [5]. On the other hand, the Romanian universities insist too much on the theoretical training and tend to produce super-skilled graduates [1].

Currently, there is a gap between the present education of engineers and the expectations of their roles in the engineering workforce. In our country, many engineering graduates have difficulties when moving from schooldays to employment. Using the ICT-based education, engineering education can more successfully bridge the gap between the lecture theatre and the engineering profession [5], and ensure a long life learning approach.

Because the higher education in chemical engineering assumes the difficult task of creating specialists with good knowledge in the area of chemical and biochemical processes, the academic community in the Faculty of Applied Chemistry and Materials Sciences in University „Politehnica” of Bucharest has been involved in several projects for developing e-learning applications for technical higher education, aiming to offer adequate tools for customized on-line and off-line training.

A theoretical framework for technology-pedagogy relationship in developing e-learning systems for chemical and chemical engineering education has been the basis for the system and content development. All considerations presented in the followings are based on the experience gained by the teaching staff of Faculty of Applied Chemistry and Materials Science, University "POLITEHNICA" of Bucharest in the activity carried out in 2002 – 2012 time interval, with special references towards two major projects. The first one has been aiming to develop and implement a nationwide e-learning community for chemistry teachers working with K12 students, aged from 13 to 19 (VIIth – XIIth grade), as well as to provide them with basic or advanced ICT training, and offer support for using the newly acquires skills and instruments in their day to day teaching (referred to as *project I*). The second project aims to develop an integrated e-learning portal for a university (referred to as *project II*). Major partners in these projects have been the University "Politehnica" of Bucharest and Siveco Romania S.A, an important software company in Romania.

2. Learning management system development

It has become increasingly common for universities and other educational institutions to support learning activities with e-learning platforms. The range of use extends from simple sharing to more complex forms of socializing. Apart from being a usable medium, an e-learning platform is also a basic communication means that, similar to websites, has to attract, engage, and hold users.

There is a broad spectrum of activities which constitute e-learning, from straightforward applications which enhance classroom activities to full distance, online and remote learning. If in the early days of e-learning, the systems were oriented towards solving well-defined problems (having an unique, determinate purpose) and their change and continuous adaptation meant a great deal of work and material resources, today's research has been oriented towards systems able to extend and adapt to any situations. Moreover, e-learning systems should provide support for students' collaboration, offering multiple ways of learning: solitary learning (documents accessible via the internet, downloadable from the Internet or on external media: CDs, video boxes), scheduled classes (direct interaction between the subject and object of learning), and group learning (online forums and chat-rooms).

The main factors, critical for operating any e-learning system are:

- *availability*: the system should be robust enough to serve simultaneously the different needs of thousands of students, administrators, content developers, and instructors;
- *adaptability*: infrastructure should allow further expansion under new requirements;
- *utility*: it must be intuitive and easy to use (to be as natural as Internet browsing) and should include many automatic features in order to minimize user's work;
- *interoperability*: the system should support content from different sources, in different formats, different solutions offered by various hardware / software vendors, it must be based on Open Source technologies, meet coding (XML, SOAP and AQ) and education (AICC, SCORM, IMS and IEEE) standards;
- *stability*: it must be operable at any time and should handle all situations for which it has been designed;
- *security*: the system must insure content safety by controlling access to resources.

Shortly, a good e-learning system is supposed to fulfil all of the following requirements:

- support education on a widely used Web-based platform, with a low cost,
- assemble and deliver learning material quickly, in several languages ,
- measure the effectiveness of educational activities,
- combine the concept "class of students" with the concept "education through the Internet / e-learning",
- centralize and automate administrative activities,
- be portable and implement standards such as AICC, IMS, SCORM.

These features have become a part of the first e-learning portal that has been developed and tested in the Faculty of Applied Chemistry and Material Science (FACMS) of University 'Politehnica' of Bucharest starting with 2004 (figure 3).

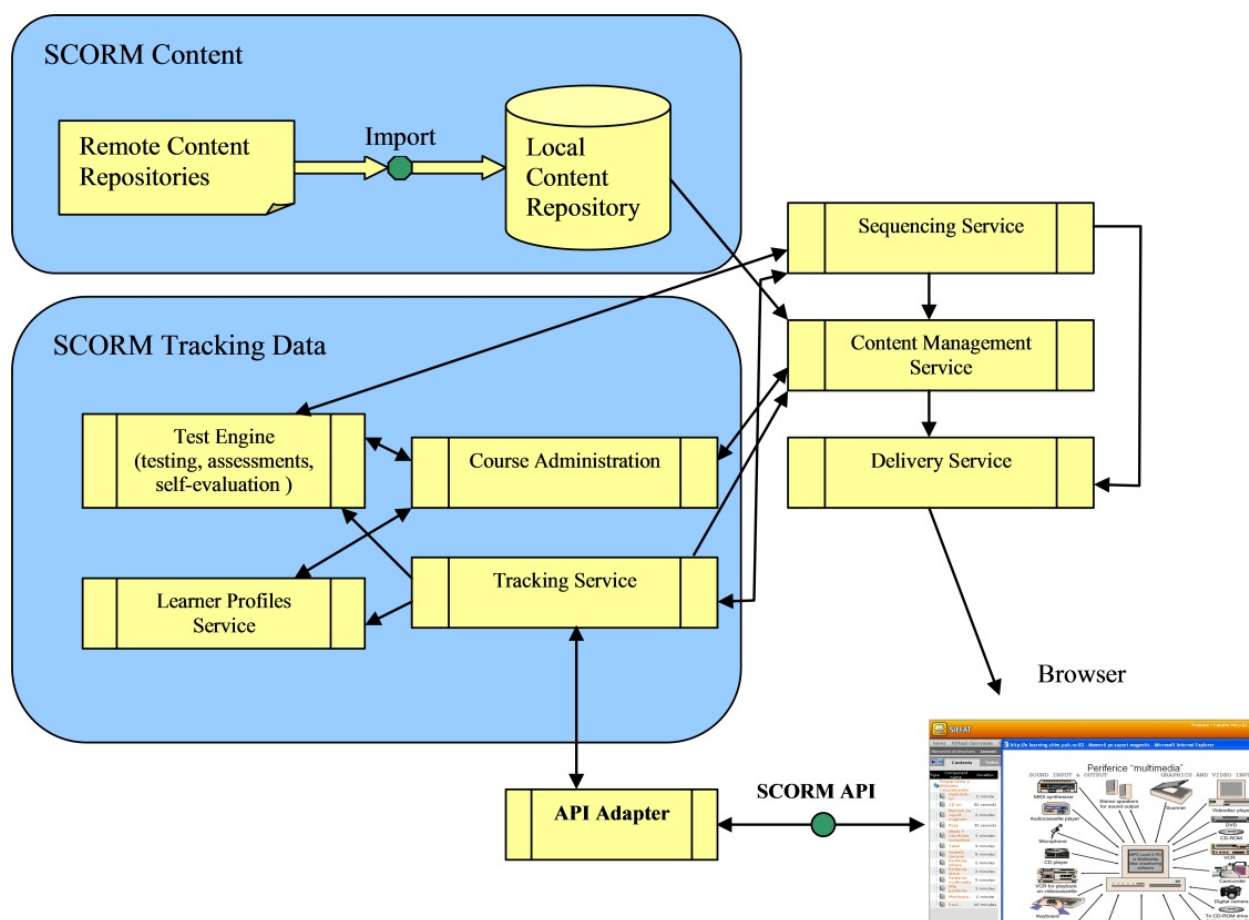

Figure 3. SeLFT – a Learning Management System developed in FACMS

As for the learning strategies, they should be selected as to motivate students, facilitate the deepening of information, promote an effective learning context, encourage interaction, provide feedback, and offer support during the learning process.

The system has supported the management of the students activities in the University by:

- realistic management of the teaching activity in the faculty;
- offering standardized educational content specific for technical faculties such as: process simulation, virtual experiments, virtual laboratories for chemical analysis, dedicated charts and graphs;
- integration of process simulation with modern analysis equipment and implementation of a remote control laboratory for monitoring environmental quality;
- development of students communication skills;
- integration with specialized software applications (IOLS, simulators, editors, video conferencing, CAD software, dedicated platforms, virtual dictionaries, and encyclopaedias);
- building a larger flexibility for individual study (online and offline courses in some defined periods of time, nonlinear scroll of the support material, adaptive testing, teacher assisted or unassisted learning / assessment).

The platform created by Siveco Romania S.A. and tested in the University 'Politehnica' of Bucharest attempted to fulfil all the requirements presented earlier. Besides offering basic information for the on-going subjects, AEL topped up by creating a virtual library suitable for all level students. The content of this library consisted of various documents: lectures, problems, project themes, project instructions, images, and videos, tests, created in-house by the academic staff and available to all authenticated users. Re-usage of e-lecture materials and the collaboration of all interested players, within the developed systems, provided a larger and better base for Process and Chemical Engineering education.

SeLFT, the e-learning platform implemented in 2004 in the Faculty of Applied Chemistry and Material Science of University 'Politehnica' of Bucharest was initially developed for synchronous study, offering larger access to the educational content in terms of location and time. For the first 4 years the access to the platform was limited to working stations on the faculty premises. Security reasons imposed this restricted access policy via Internet. An off-line study module was later designed and integrated in the updated platform AEL [6, 7], so that all interested users became exposed to synchronous and asynchronous instruction. In terms of communication the platform offered a special forum facility used by students to post any type of announcement, send messages and files.

The tested portal offered users (students and academics) five different spaces: personal homepage, teaching/learning, workspace, collaboration, and administration (figure 4). Common document, drawing board, agenda, meeting notes, instant messaging, private discussion, Web tour, slide presentation, audio and/or video conferencing represent the tools available in the workspace. The portal has been highly appreciated by those who have used it for training purposes in the chemical engineering undergraduate curricula. The next stage in the development of this portal has been a remote laboratory for environment quality monitoring.

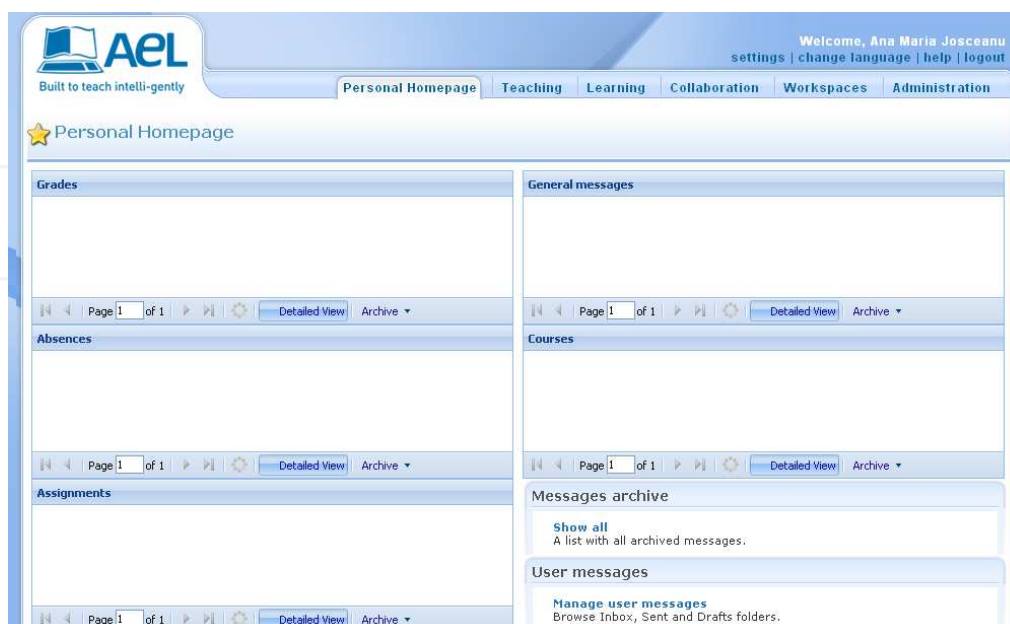

Figure 4. Modules in the e-Learning portal developed in project II

Thus engineering students have been offered a mixture of real and remote laboratory facilities. The remote control experiments allowed students to acquire good laboratory practice skills and experience related to real equipments in an intuitive and cost-effective way. Another attractive advantage was represented by the chance of free and flexible training in contrast to a fixed and regular class schedule. The design and delivery mechanism for the new module of the e-learning portal were tailored as recommended in the literature to: i) provide a constructivist pedagogical approach; ii) model a collaborative learning environment for group interaction; iii) match the characteristics of the delivery media to specific learning processes (media-synchronicity theory) including the provision of unambiguous feedback and guidance; iv) assign appropriate instructional roles, and v) determine desirable student competency outcomes, all in a remote learning context. A multi-tier role architecture consisting of faculty facilitators at both local, and remote sites, and students, has been used and adapted to maintain academic integrity and offer the same quality of interaction as the on-site laboratory activity. The interface between the user and the automatic machine is developed in Visual Studio .net and PHP. The automatic machine is split into an interface, firmware component developed in assembly language, and a hardware module, composed by microcontrollers from PIC family. The communication is established as Ethernet 10 MB and uses standard protocols like TCP and UDP.

2.1. Advanced communication and collaboration module

In terms of communication SeLFT in use at the Faculty of Applied Chemistry and Material Science offered a special forum facility used by students to post any type of announcement, send messages and files.

According to the feedback collected, an optimal e-learning platform should provide facilities to let team members (students, instructors, administrators, and technical staff in an e-learning model) access a series of shared content libraries and make use of a broad range of services that include:

- access to news and announcements, presented to members when they log in to the platform (also available in the form of alerts, which can be auto-generated and mailed to team members by request);
- mechanisms for submitting documents for comment, review, and approval, with the ability to track status, ownership, tasks, and assignments;
- shared lists for tasks, calendars, schedules, and other group/team activity-scheduling, and inquiry mechanisms;
- support for interactive discussions through message boards, instant messaging, and e-mail distribution lists;
- support for online meetings, either text-only or with voice and/or video capability, as well.

Obviously, technology in and of itself does not guarantee better learning. But when effectively used, technology can help focus attention while attracting and maintaining the learner's interest. Interests identified among engineering students were very much oriented towards collaborative activities. An off-line study module, with off-line communication

channels (forums, discussion boards, and file sending) does not support effectively their joint projects and real-time communication needs. A new version of the AEL Enterprise platform designed by Siveco Romania S.A. has offered the higher education user three different spaces: a learning space, a teaching space, and an integrated working space. The last is provided with both off- and on-line communication channels, and collaborative working tools. Requiring additional hardware, the newly deployed working space offers audio and videoconferencing, common document creation, web tours, drawing board, slides presentations, chat, private discussions and/or video conferencing. The platform has been thoroughly evaluated in the academic community, as to determine viability, versatility, and effects on the learning and teaching process. The news and announcements of general interest, as well as the personal messages among users are substantially augmented. The messages and announcements of general interest can be seen by all users, even if they are not authenticated. Personal messages are available only after authentication. The users are automatically notified by personal messages, which can be auto-generated and mailed to team members by request, when they are associated as students to a course or when synchronous sessions, which they must attend, are scheduled.

During collaborative sessions, participants are generally given similar rights, such as sending and receiving audio/video signal, web tour or using drawing board when the session is set up. There is a session host with additional duties, being the only role entitled to end a session, add or remove participants, and define their individual rights [8]. Before sending the invitation to join a collaborative session, the host may define a meeting agenda or load an existing one. The collaborative mode is the implicit one for videoconferencing (Figure 5).

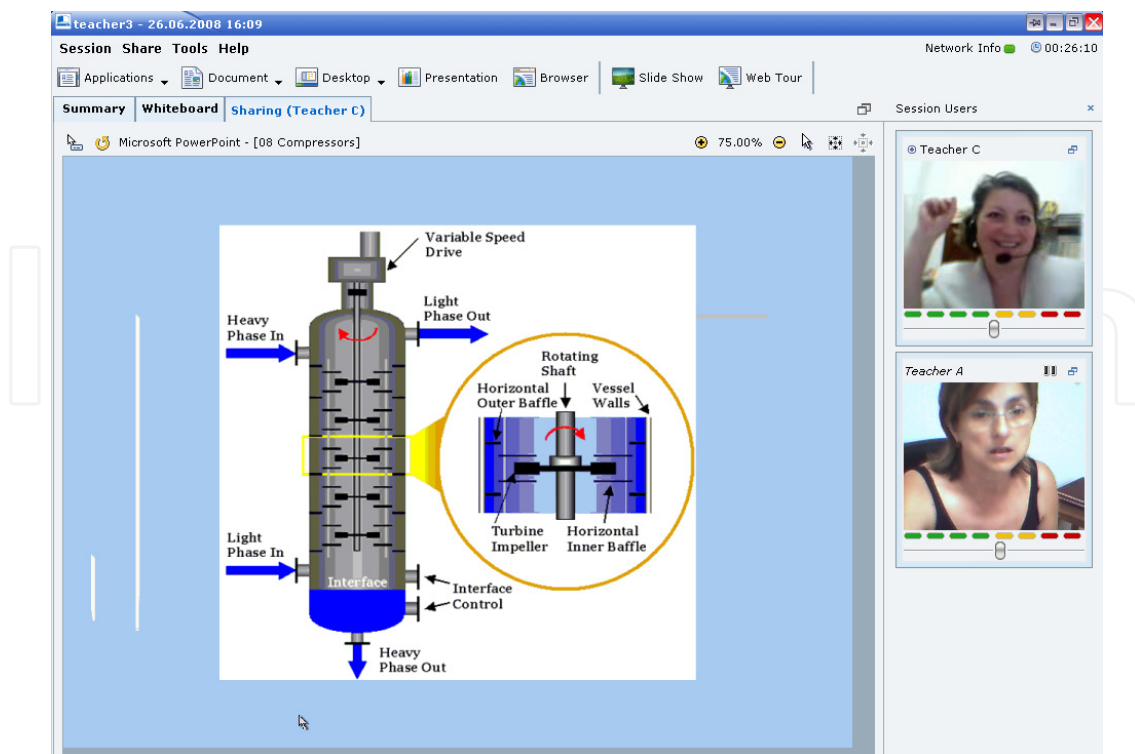

Figure 5. Videoconference session for a distillation column design

When working on projects, one of the students might be given session co-hosting duties. This may be the case when the academic in charge chooses not to attend the working session, and leaves the group to interact and collaborate in a more flexible and friendly environment.

The common workspace and applications facility give the participants the chance to contribute to Windows Word, Excel, PowerPoint, PDF and other specialized type files, provided that each participant has installed the corresponding application on his working station. Otherwise, only common visualization is possible, without editing. This facility offers the possibility to visualize and control an application running on another system, or the entire workspace of a computer. There is also the possibility to offer remote control of an application running on another computer when the keyboard and mouse are remote-controlled. Signal stability during medium length sessions (up to 45 minutes) proved to be satisfactory for the network transfer rate. Each user chooses to make use of all, one or none of these communication channels, according to physical availability and hardware performances. Best results were obtained when similar hardware was used by all participants in a session.

Nevertheless, the communication and group work facilities were ranked as rather insufficient by 75 % of the interviewed users, pointing out the need for further development if access and motivation, on-line socialization, information exchange, knowledge construction, and personal development remained the favoured pedagogical tasks.

2.2. Registrar function

In order to implement correctly and efficiently the legal stipulations regarding university studies (technical, economic, medical, judicial, and vocational), it is necessary that specialized entities in the universities (university or faculty registrar services) collect and process information regarding:

- students (personal data, contact, economic and social status),
- directions of specialization chosen after the first education cycle,
- credit accumulation along the education process,
- higher education mobility possibilities for Romanian and foreign students.

Besides bachelor studies, University 'Politehnica' of Bucharest organizes, according to the legal stipulations, master studies, doctoral, and post doctoral studies. All the possibilities stipulated by the law must reverberate in the management instruments of the university. They imply a complex activity for the administrative staff, in order to provide documents following individually the students, their retention and success rates, the professional route, and finally issue the graduating diplomas.

A registrar specialized module has been stipulated in the frame of the e-learning portal for universities (figure 6), in direct relation with the management of student academic activity. It has been designed to ensure:

- the management of faculties organizational structure in a university, with unique or various activity domains,

- implementation of recording, communication, and analysis procedures for the professional achievements of the students in correlation with the principles of quality assurances in university studies.
- the management of students achievements along their academic education, for any of the study degrees organized by a university,
- marking books administration,
- students information on their academic status and on the decisions they have to take in order to fulfil the requirements of the chosen curricula,
- generation of statistics regarding the students activities.

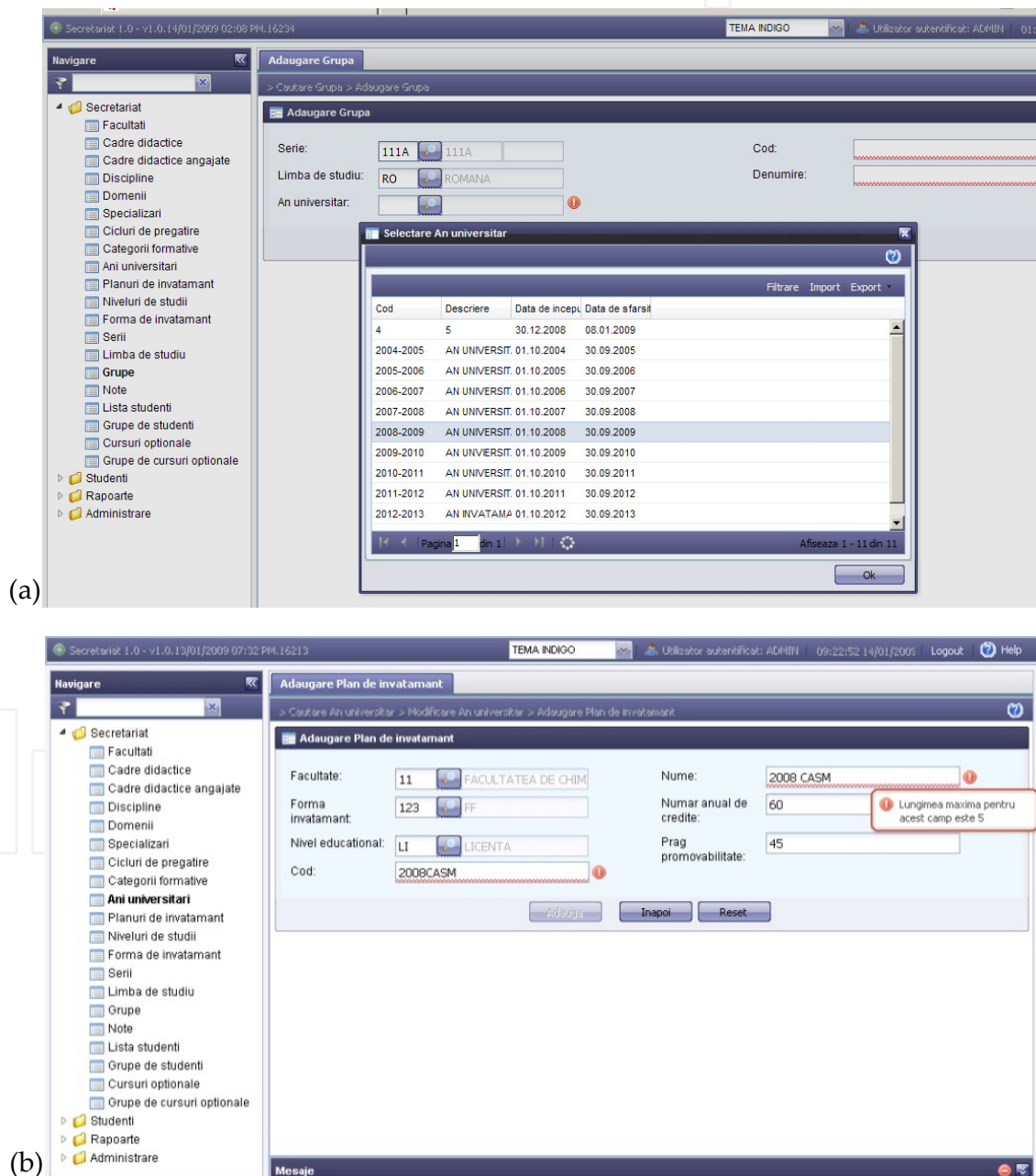

Figure 6. Secretarial application for an university with unique activity field

The basic administrative documents of any faculty, regardless its profile, importance or the university it belongs to, produced for any academic year are various and numerous (educational programs, catalogues, studies contracts, etc.). The informatics application centred on the management of the information and data flux from the university administration is integrated in the context of all other informatics applications implemented in the university. The development of these applications supports and improves the exchange of information and data within the organization.

According to the necessities of information, management, and analysis specific to the academic environment, the application was designed and developed to fulfil the following functional requirements:

1. include all educational forms legally stipulated: bachelor, master, doctoral studies, short term courses,
2. diversify the possibilities of assessing students activity, for any course, by introducing up to 6 components (laboratory, seminar, personal assignment, partial examination, other marks, final mark) with an editable weight,
3. implement academic staff evaluation by students through confidential surveys. The surveys are administered through the system, and results can be visualized only by the evaluated professor and by the faculty dean.
4. report generation in connection to the educational process evolution:
 - number of students enrolled in each education form (license, master, doctoral studies, post doctoral studies etc.)
 - student distribution as a function of age, gender, nationality, citizenship, last education form he/she graduated, etc.
 - rate of success, in all sorts of forms, such as:
 - reports at the end of each examination period, and of the university year,
 - reports per discipline and/or teacher,
 - reports concerning the number of credits obtained by each student,
 - reports concerning the number and names of the students who passed all the exams as a function of the domain, series and groups,
 - reports on the students as a function of the number of failed exams (N-1, N-2,etc.) and the correlation of the failed disciplines with the number of missing credits;
 - accountancy of the students who need re-examinations as a function of the disciplines and / or teacher.

The access in the system is controlled and secured by defining the users, user groups, and access rights for various functionalities and documents. For obtaining information from the system each user must authenticate itself when connected. After closing the session the system will not allow the access to the closed application (by using „Back“ function of Web browsers).

Users are grouped on the ground of the functions they have in the university or the registrar office. A user can belong to one or several groups. Each user is able to access only the

documents and information for which he has an explicit permit. The administrator defines the access rights for each group of users, and each system function. The access rights are also specified at folder level.

3. Technology-pedagogy relationship in developing content for e-learning systems

Nowadays, the rapid evolution of information and communications technology creates new opportunities for multimedia instruction and education, ranging from ways of delivering content to ways of expressing this content, but similarly strong claims are being made for the potential of multimedia learning environments. In this context, natural questions arise: how can be avoided a trail of broken promises concerning the educational benefits of new educational technologies such as multimedia learning environments, and how to use these new opportunities for delivery and expression of educational content in order to maximize learning? A reasonable solution is to use instructional technology in ways that are grounded in research-based theory. There is a (natural) developing tendency for multimedia instruction and systems, from instructor-centred environments to learner-centred environments. In such circumstances, concerns about the efficiency of such systems are even more justified. Unfortunately, there still is a lack of standardization in what concerns the development principles of multimedia instruction and education systems; there is a tendency of content developers to create environments with spectacular components rather than educational ones that ultimately proves to be a counterproductive practice. The efficient use of technology-pedagogy relationship in developing multimedia instruction and education systems is, ultimately, a matter of usability. Usability concerns the measure of a product potential to accomplish the goals of the user. There are different levels of usability focus in developing multimedia systems, spanning from navigation to the use of colours, text, and graphics. Usability, and particularly learner friendliness is one of the most neglected areas in e-learning design and implementation. Too much focus on developing the application and not enough focus on the implementation is also a major problem. The main problem is that developers think the job is done when the application is developed. So, even if the applications have a high quality, the usability can be low. Increasing the quality of both content and functionality of the application can represent increased value for users of an e-learning product. Addressing usability issues guarantees that the learning environment doesn't become a barrier to learning. Consequently, learners are able to work through a course, with minimal distraction or frustration.

Besides considering technological issues, usability principles must rely on an *educational theory*, somehow driving the designer in developing suitable applications. Currently, the constructivist theory is almost universally adopted. This theory stresses that learning is a personal process, characterized by individual's developing knowledge and understanding, by forming and refining concepts. This leads to the view that learners should be assisted in some way to construct and refine concepts in personally meaningful ways. From a constructivist perspective, learners need to be encouraged to take responsibility for their learning, while generating a sense of ownership of learning experiences.

First of all, in e-learning, usability is defined by the ability of a multimedia object to support or enable a particular concrete cognitive goal. Concepts, such as working memory, cognitive load, production system theories of knowledge and learning, self-explaining behaviours, all become important considerations for the instructional designer who must learn to use technology effectively and intelligently, rather than simply because it is available and seems flashy or exciting. The human mind is limited in the amount of information it can process. Because computer-based training can quickly overwhelm these limited capacities, it becomes important for the instructional designer to understand the principles of cognitive science and how they apply to effective instructional design for multimedia instruction and education. Cognitive Load Theory (CLT) states that the working memory is limited in its capacity to selectively attend to and process incoming sensory data. Working memory is a concept that grew out of the older model of short term memory, which was seen more as a structure for temporarily storing information before it passed to long-term memory. The model for working memory is a system with subcomponents that not only held temporary information, but processes it so that several pieces of verbal or visual information could be stored and integrated. CLT is concerned with the way in which a learner's cognitive resources are focused and used during learning, suggesting that for instruction to be effective, care must be taken to design instruction in a way as to not overload the mind's capacity for processing information. The implication for multimedia and education is that if we only have a very limited amount of information processing capacity in the working memory at any single moment, then instructional designers should not be seduced into filling up this limited capacity with unimportant, but flashy content in a multimedia instructional unit. An example of what this means for multimedia instructional design is that the layout should be visually appealing and intuitive, and that activities should remain focused on the concepts to be learned, rather than trying too much to entertain. Content knowledge is organized into schemas found in the long-term memory, and these schemas control how new information is handled as it enters the working memory. Schemas organize simpler elements and can then act as elements in higher order schemas. In other words, as learning occurs, increasingly sophisticated schemas are developed and learned procedures are transferred from controlled to automatic processing. Automation frees capacity in the working memory for other functions. CLT suggests that instructional techniques that require students to engage in activities that aren't directed towards schema acquisition and automation can quickly exceed the limited capacity of the working memory and hinder the learning objectives. In simple terms, this means that you shouldn't create unnecessary activities in connection with a lesson that requires excessive attention or concentration that may overload the working memory and prevent one from acquiring the essential information that is to be learned. This is an important rule in any form of instruction and education, but it is an essential rule in multimedia instruction and education, because of the ease with which distractions can be incorporated.

A model of knowledge transmission in the classical (non-virtual) educational process is based on presenting information, followed by the proposal of problem items which students should solve based on the information presented. Unfortunately, this model, which has been also incorporated in multimedia instruction and education, skips an important step between

the presentation of information and problems proposals, namely the presentation of worked-out examples, as well as the algorithms and techniques recommended to work out these problems. If we consider that multimedia technology is extremely generous in terms of expression modes, when it comes to presenting a theoretical concept, then definitely it is even more suitable, by the multitude of technical possibilities of expression, when it is used to present the problems solving methods. Providing learners with worked-out examples can be very useful. This means that if a multimedia instructional unit was appealing enough to hold the learner's attention and cause the learner to really study the process of a worked-out problem in detail, then it could likely be just as much or more effective than having them work the problem out themselves.

In developing interactive media, the design of the user interface, system architecture, and navigation tools are often left to chance. It is well known that with emergence and development of interactive media, and especially of the World Wide Web, promoted the philosophy of nonlinear content scrolling, which was one of the strengths which has imposed new ways of presenting information in relation to the traditional ones (printed materials, television, radio, etc.). Here are some usability best practices in this respect:

- The system should always keep users informed about the application's status, through appropriate feedback within reasonable time. This can be done by visible indication so that the user is notified about the place he/she is in the application, as well as how this place is related to other components available in the application. Thus, it can be specified the current page number, number of pages viewed, current page address in the application architecture, the current chapter name, etc. There is also useful general information about applications, such as status updates.
- Navigation elements must ensure any time fast user access to any segment of the application. The existence of multi-level menus is welcome, given that they reflect the application architecture.
- Links must be identified as to express clearly if they represent access to other instruments than usual content segments.
- Excessive linear navigation must be avoided. For instance, the user should not go through substantial amounts of content to reach a certain place in the application. It is a good idea to include an index and search function for extensive multimedia applications.
- The system should keep users informed about progress tracking.
- Users must be provided with printer friendly alternative content.

Some of these principles, applied to the interface of the interactive educational system developed in the framework of project I are illustrated in Figure 7.

But it is also highly important that the principles of non-linear navigation are designed keeping in mind the way working memory works, and not least its capacity. One of the problems we face in this context is split-attention. Split-attention occurs when learners are presented with multiple sources of information that have to be integrated before they are understood. The instruction should not be designed in a way that forces the learner to divide his attention between several tasks.

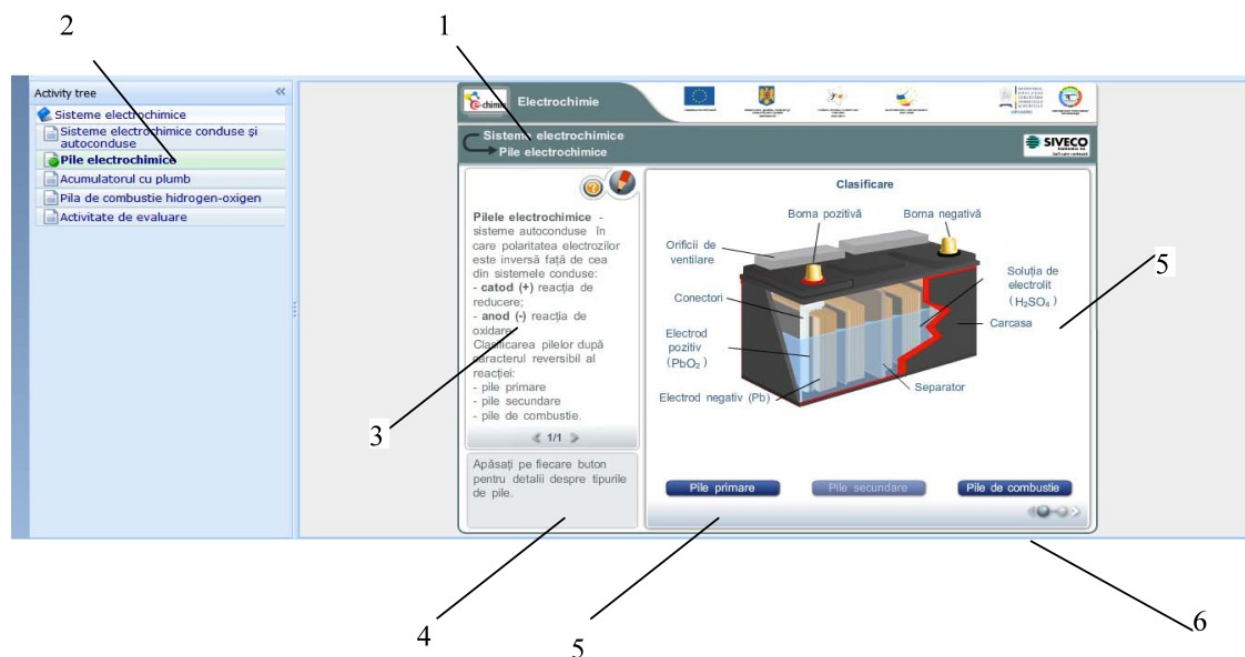

Figure 7. Principles of usability applied to the navigational system of a multimedia instruction system – the architecture of the system interface: 1 – Indications about the place in system; 2 – Table of contents; 3 – Information broadcasted through text channel; 4 – Instructions for using the multimedia application; 5 – Elements for navigation within the multimedia application; 6 - Elements for navigation within the chapter; 7 – Multimedia application.

For instance, in laboratories, both classical and virtual, it is required that the student follows specific steps: acquiring information regarding the laboratory objective, theoretical concepts, constructive and functional presentation of the equipment, mode of operation, data processing and interpretation.

Often there is no clear boundary between these thematic modules, and the learner's attention should be split in several tasks, with negative consequences on the process of knowledge understanding and integration.

Solutions must be found for organizing the information, based on existing multimedia technologies that avoid split-attention. We present here an example where we used simple Web technologies to organize educational material that represents a virtual laboratory (project I). Figure 8 presents a screenshot of this application. As it can be seen, by using frames in HTML technology, the content is divided into three main areas: the area of general data, the table of contents, and the content area. This splitting allows the student to have always availability over the general data and over the content structure, as he/she browses it. The content area is, in turn, split in two parts: a text area and a multimedia area (in which graphic, video, and audio content, interactive animations etc. can be presented). This approach allows the student to browse smaller or larger amounts of text, without losing the multimedia material to which reference is made to in this text from the visual field. This information organization is a collection of best practices related to non-linear navigation opportunities provided by the information and communication technology.

Laborator virtual - Cinetica Chimica v 1.0 1

[Concepte teoretice](#)

Lucrari de laborator virtual

[Lucrarea nr. 1](#)

[Lucrarea nr. 2](#)

[Lucrarea nr. 3](#)

[Lucrarea nr. 4](#)

[Lucrarea nr. 5](#)

[Lucrarea nr. 6](#)

[Lucrarea nr. 7](#)

[Resurse suplimentare](#)

[Acknowledgement](#)

Lucrarea de laborator virtual nr. 1

1. Familiarizati-va cu [descrierea aplicatiei](#) si cu [modul de lucru](#).

2. Rulati simularea si calculati viteza de reactie pentru cele 3 valori ale variabilei timp.

3. Raspundeti la urmatoarea intrebare: 3

Cum este valoarea vitezei de reactie pentru cele 3 valori ale variabilei timp?

0s 0,0125 mol/(L*s) 0,00169 mol/(L*s) 0,000374 mol/(L*s)

4s 0,0125 mol/(L*s) 0,00169 mol/(L*s) 0,000374 mol/(L*s)

2

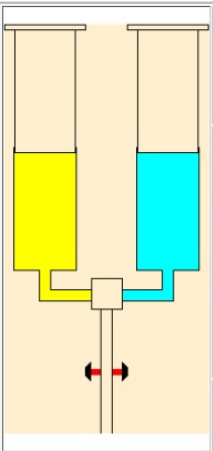

Start

Stop

Reset

Time

0 sec

4 sec

7 sec

Species

A

B

C

slope (mole L⁻¹ sec⁻¹)

4

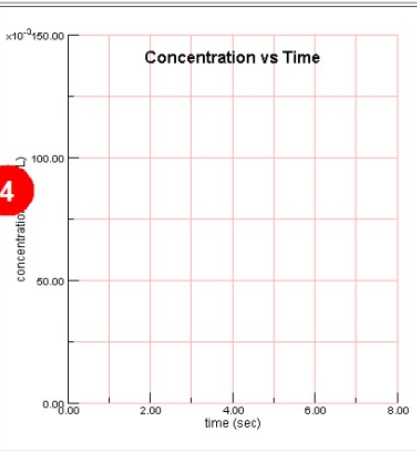

Laborator virtual - Cinetica Chimica v 1.0

[Concepte teoretice](#)

Lucrari de laborator virtual

[Lucrarea nr. 1](#)

[Lucrarea nr. 2](#)

[Lucrarea nr. 3](#)

[Lucrarea nr. 4](#)

[Lucrarea nr. 5](#)

[Lucrarea nr. 6](#)

[Lucrarea nr. 7](#)

[Resurse suplimentare](#)

[Acknowledgement](#)

Instalatia simulata este formata din doua recipiente cilindrice cu piston, in fiecare dintre recipiente aflandu-se cate o specie chimica, A sau B. Prin deplasarea rapida a pistonelor, cele doua specii chimice sunt amestecate cu o viteza foarte mare, practic instantaneu. Imediat dupa amestecarea incepe reactie chimica:

2A + 3B → 5C

S-au atribuit urmatoarele culori celor 3 specii chimice: A - galben, B - albastru si C - rosu. Se observa ca imediat dupa momentul amestecarii, masa de reactie este verde, ceea ce sugereaza un amestec strict fizic

5

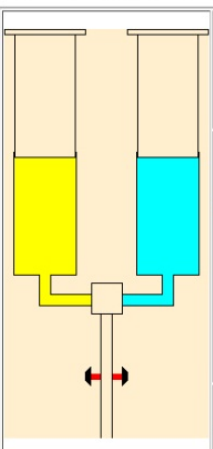

Start

Stop

Reset

Time

0 sec

4 sec

7 sec

Species

A

B

C

slope (mole L⁻¹ sec⁻¹)

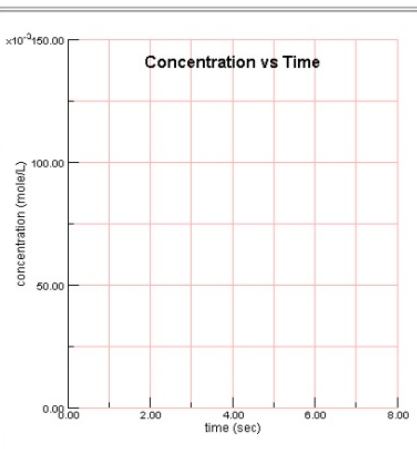

Figure 8. HTML technology usage for screen division in a multimedia instruction system for a virtual laboratory experiment: 1 - General data area; 2 - Table of contents, 3 - Text area; 4 - Multimedia area; 5 - Pop-up window overlapping the main text.

When the student is directed to the content of a virtual laboratory, he finds the content structured in a way that suggests to browse through the different information modules in an absolute individually way.

Before starting the laboratory, the student is guided to the module attending the constructive and functional presentation of the equipment, and the operation mode, however being not obliged to go through it, if he considers himself familiarized to this piece of information from previous educational experience. If he/she accesses the link to any of these modules, a pop-up window appears, which overlaps with the main text, thus not allowing temporary access to it, but that does not overlap with the interactive application that simulates the equipment. This way, a selective, contextual presentation of information is achieved. Moreover, this content structure is subject to the contiguity principle, which states that better transfer occurs when corresponding contents are presented simultaneously, both temporally and spatially. Temporal contiguity means that corresponding words and pictures are presented at the same time, while spatial contiguity means that corresponding words and pictures are presented near rather than far from each other on a page or screen. In other words, an important visual image should not be placed on one page or frame, and then discuss it in a preceding or following page/frame without continuing to show the visual image.

The split-attention problem arises not only in determining the optimal navigation system in the virtual environment, but it is also related to the information presentation in a multimedia application. There are situations when presentation of a theoretical concept through the aid of a static graphical item requires a high information density. In physics and chemistry such situations are quite common, for instance when understanding a process requires presentation of macroscopic aspects, but also the microscopic intimacy of the process. Presentation of the two categories of information together, in the same image, impedes process understanding, while presenting them in different images dilutes the logical connection between the two aspects. In the frame of project I the simultaneous presentation, in the same multimedia application, of both macroscopic and microscopic aspects of the studied process was necessary. A simple and elegant solution was adopted, and, according to the feedback collected from students, it proved to be a real success. When running the application, the user can watch the process evolution at macroscopic level; when he/she is quite familiar with it, he/she can, by moving an instrument available permanently on screen, in a particular area of simulation, visualize the microscopic level evolution for the specific area (as demonstrated in Figure 9).

Another critical factor that must be taken into account in developing educational multimedia materials is pacing. The pacing principle states that better transfer occurs when the pace of presentation is controlled by the learner, rather than by the program. Learners vary in the time needed to engage in the cognitive processes of selecting, organizing, and integrating incoming information, so they must have the ability to work at their own pace, to slow or stop the presentation if necessary. If the pace of the presented material is too fast, then the cognitive processes may not be carried out properly and learning will suffer. Also, if the pace is too slow, that can lead to student irritation, with negative effects on the educational process. A technical

solution at the reach of multimedia developers is the possibility of attaching a slider to interactive applications, through which the user can pause, rewind, and fast-forward the application. This technique was used in many multimedia applications developed for project I (see an examples from project I in figure 10).

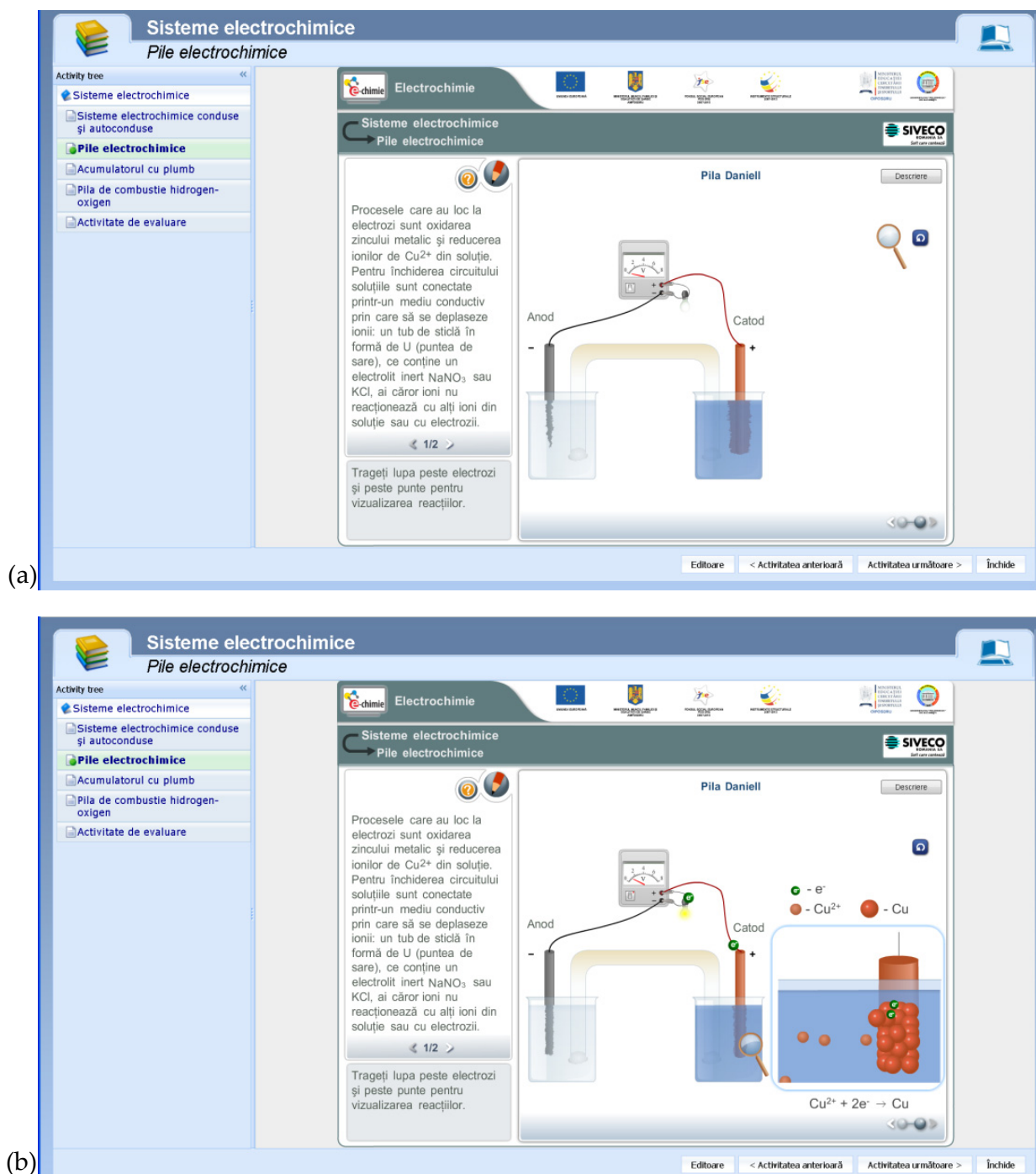

Figure 9. Visualization of an electrochemical process at macroscopic (a) and microscopic levels (b).

An important usability dimension in developing multimedia instruction and education systems relates to the degree of planning and structuring the learning activities. Different

learning contexts need different types of applications in order to support the activity task. For example, a multimedia application useful as support for quick help may not be a usable learning support in a continuous perspective. The content may be similar, but the context is different. This has important implications for usability, because the context partially determines how a given application will be used. Consequently, analysis of the learning context is vital. Within project I a situation somewhat atypical in terms of this so-called learning context was faced. As it has been previously mentioned, the project objective was to create a virtual educational environment for chemistry teachers working in the K12 education system, but also to offer guidelines for using it. Consequently, we have had to deal with a double educational process, with two categories of end users. On the one hand it is about knowledge transfer from instructors to teachers, followed by another transfer, this time from teachers to students. In this equation, teachers are learners in the first phase, and become instructors in the second. Consequently, application development had to be carried out in such a way that it could be used in both educational contexts, with maximum efficiency. The biggest challenge has been the design of applications for both adult learners and young learners. It is well-known that adult learners have another set of motivations than young learners.

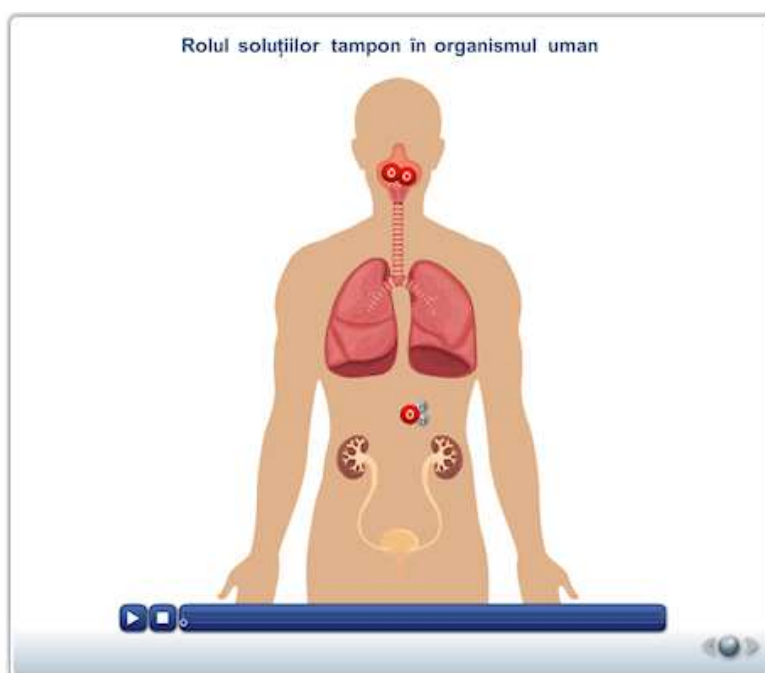

Figure 10. Using sliders in multimedia applications: The role of buffer solution in the human body.

Adult learners need to know why they should learn something, want to learn experientially, approach learning as problem-solving, and accumulate best when the topic is of immediate value. Another feature of this project is linked to the fact that learning activities planning and structuring do not aim to bring around an alternative way to traditional learning, but to create a significant shift from traditional learning to e-learning. Learning is carried out in social settings, by adopting ideas, ways of thinking and how things are done. Introducing new learning methods like e-learning will normally alter the existing learning culture. Not

only what we learn, but also how we learn becomes a major issue. Understanding the target audience should help in defining the communication style of the newly created e-learning environment. Where appropriate, learner's profile must be used to develop an instructional design, style, and tone. To improve the readability of an e-learning environment, natural language must be used, avoiding slang or acronyms. As it has been declared previously, the constructivist theory is almost universally adopted in the e-learning philosophy. Recently, the constructivist approach has been significantly extended from social perspectives to so-called socio-constructivism.

But how is it possible to project this social component of constructivism into the technical solutions used in developing instructional virtual environments? The answer is simple: given that the educational multimedia content is mostly delivered through web technologies, the shift from Web 1.0 to Web 2.0 can bring a quantum leap in expressing educational virtual environments. Web 2.0 defines web features that facilitate participatory information sharing, interoperability, user-centred design, and collaboration on the World Wide Web. Web 2.0 allows users to interact and collaborate with each other in a social media dialogue as creators of user-generated content in a virtual community, in contrast to websites, where users are limited to the passive viewing of content that was created for them. The shift to Web 2.0 has its counterparts in both e-learning technology and methodology. Thus, Web 2.0 concept can result in the e-Learning 2.0 concept, for which one of the core support methodologies is connectivism, concentrating on making connections among learning resources and people. e-Learning 2.0 emerges inspired by the popularity of Web 2.0, which places increased emphasis on social learning and use of social software. Conventional e-learning systems were based on instructional packets that were delivered to students using Internet technologies. The role of students consisted in learning from the reading and preparing assignments. By contrast, e-Learning 2.0 is built around collaboration, which assumes that knowledge is socially constructed. Learning takes place through conversations about content and grounded interaction about problems and actions. Collaborative learning has been found to increase student motivation and enhance their performance. Through collaboration, students become actively engaged in the learning process, exchange ideas, and produce knowledge, helping other students to better understand the learning material. In contrast to traditional education, typical e-learning environments lack face-to-face interaction between students. Therefore, the introduction and adaptation of collaborative techniques in these environments is especially necessary. Successful design of collaboration will help students to feel less isolated and become part of the virtual course community, resulting in better educational performance, motivation, and persistence in the course. Many strategies are proposed, focusing on promoting communication, social interaction, and participation to scaffold e-learning. Therefore, it is desirable to design and develop learning environments to achieve e-Learning 2.0, encouraging learners' active involvement to resource contribution, enabling convenient resources accessing and utilization, and facilitating better interaction and collaboration. One of the ideas with great potential in this direction (but that unfortunately remained, so far, more in this idea stage) consists in achieving collaborative e-learning environments

enhanced by wiki technologies. Wiki technologies enable communities to write documents collaboratively, by adding, modifying or deleting the content. Openness of wikis gives rise to the concept of "darwikinism", which is a concept that describes the "socially Darwinian process" that wiki pages are subject to. Basically, because of the openness of wikis and the rapidity with which wiki pages can be edited, the pages undergo a natural selection process like that to which nature subjects living organisms to. "Unfit" sentences and sections are ruthlessly culled, edited, and replaced if they are not considered "fit", which hopefully results in the evolution of a higher quality and more relevant page. Whilst such openness may invite "vandalism" and posting of untrue information, the same openness also makes it possible to rapidly correct or restore a "quality" wiki page. Sustainability of the wiki concept is endorsed by achievements based on it, the best known example being Wikipedia, the largest and most popular general reference work on the Internet.

e-Learning 2.0 can also bring strong focus on content syndication, its reuse/re-purposing, adaptation, and personalization. There are high quality multimedia applications in the World Wide Web virtual space, made available for free by prestigious institutions. Moreover, the authors of these applications make available source codes, thus allowing and even encouraging their modification, in order to improve or customize them. Many websites managing these resources contain planning and structuring of learning activities customized for different educational scenarios, and, as in the case of source codes, the contribution of users is allowed and even encouraged. If in the project I educational multimedia applications were developed together with SIVCO ROMANIA S.A., one of the largest software companies in Romania, a different approach was used in project II, namely using freeware resources, existing in the virtual space of the World Wide Web: PhET, Virtual Chemistry Experiments (<http://www.chm.davidson.edu/vce/index.html>), ChemCollective (<http://ir.chem.cmu.edu/>).

Some of these are:

1. PhET: Free online physics, chemistry, biology, earth science and math simulations (<http://phet.colorado.edu/>)

PhET provides interactive, research-based simulations of physical phenomena, from the PhET™ project at the University of Colorado. To ensure educational effectiveness and usability, all these simulations are extensively tested and evaluated. These tests include student interviews in addition to actual utilization of the simulations in a variety of settings, including lectures, group work, homework and lab work. All PhET simulations are freely available from the PhET website and are easy to use and incorporate into the classroom. They are written in Java and Flash, and can be run using a standard web browser as long as Flash and Java are installed. There is a "Teacher Ideas & Activities" page, which is a gateway to instructor-submitted contributions, designed to be used in conjunction with the PhET simulations. PhET simulations are available in 6 categories (Physics, Biology, Chemistry, Earth Science, Math and Cutting Edge Research) and are organized into projects, each of which can contain one or more related simulations. For example, the "nuclear-physics" project contains 4 simulations,

including "Alpha Decay" and "Radioactive Dating Game". The source code for all PhET simulations is available for use and/or modification.

2. Virtual Chemistry Experiments (<http://www.chm.davidson.edu/vce/index.html>)
Virtual Chemistry Experiments are a collection of interactive web-based chemistry tutorials. The tutorials employ Physlets and Chemistry Applets to simulate experiments or depict molecular and atomic structure. The guiding concept is to involve the read in making observations and acquiring data, and then using this information to draw conclusions and infer chemical principles. The interactive content is made possible through the use of Java. Exercises dealing with molecular and electronic structure also employ Java3D. Virtual Chemistry Experiments web pages may be downloaded and deployed locally.

The role of usability in minimizing distraction sources for the user in the educational process is very important. One of the current sources is the coherence degree of the material. More elements shown in a material are not necessarily beneficial for learning, leading the learners to focus away. The applications with too much ornament can confuse the learner. On the other hand, the lack or the insufficiency of some absolutely required elements can create user frustration, with equally negative consequences as those caused by distraction. Consequently, it is important to find technical solutions for achieving an optimum. In this context, in the frame of project I it has been very important how to describe the virtual equipment in a virtual simulation. One of the technical solutions identified in this respect is presented in figure 11.

Thus, there is a button always present on the application screen which can bring in, at any moment of its dynamic run, the necessary information for describing the equipment. This information is presented in a transparent layer which overlaps the main content of the simulation, which will fade in the background. For expediency, this layer stays open as long as the user keeps pressing the button which calls the layer.

A particular aspect of usability is learnability. Learnability is a measure of the degree to which a user interface can be learned quickly and effectively. User interfaces are typically easier to learn from when they are designed based on core psychological properties, and when they are familiar. Familiarity may come from the fact that it follows standards or the design follows a metaphor from people's real world experience. An instructional interface is especially effective when the learner is able to focus on learning content rather than on how to access it. Multimedia content developers must be consistent and follow standards in layout and content organization: consistency ensures a predictable environment for learners. A standard look and feel for the course must be created. The organization of content and objects should be meaningful to the user. Using a minimalist design is a good practice, not only for aesthetic purposes, but also for learning. Simplicity reduces the demand on users' brain power and focuses users' attention on the task. Multimedia content developers must strive for simplicity in layout, screen function, structural design, and other program elements. Complex or extraneous interface elements unnecessarily burden users' working memory. The colours should be used wisely and the application must not rely on colour alone to communicate a message.

Chimie fizică

Echilibrul chimic

Analiza procesului Haber-Bosch (sinteză amoniacului din elemente pe catalizator de fier poros)

Procesul de sinteză a amoniacului din elemente este exoterm și decurge cu scăderea numărului de moli de gaz, fiind favorizat de temperaturile reduse și presiunile ridicate. Dependența avansării reacției de temperatură și presiune nu este, în mod necesar, însoțită de o modificare corespunzătoare în constanta de echilibru.

Modificați valorile temperaturii și presiunii. Urmăriți modificările din compoziția amestecului și variația concentrației.

$N_2 + 3H_2 = 2NH_3$

$X_{N_2} = 0,2078$ $X_{H_2} = 0,6233$ $X_{NH_3} = 0,1689$

$K = 0,00001$
 $K_x = 0,567$
 $P_0 = 1 \text{ bar}$

220

6700 K

100 300

500 700

(a)

Chimie fizică

Echilibrul chimic

Analiza procesului Haber-Bosch (sinteză amoniacului din elemente pe catalizator de fier poros)

Procesul de sinteză a amoniacului din elemente este exoterm și decurge cu scăderea numărului de moli de gaz, fiind favorizat de temperaturile reduse și presiunile ridicate. Dependența avansării reacției de temperatură și presiune nu este, în mod necesar, însoțită de o modificare corespunzătoare în constanta de echilibru.

Modificați valorile temperaturii și presiunii. Urmăriți modificările din compoziția amestecului și variația concentrației.

$N_2 + 3H_2 = 2NH_3$

Fracțiile molare ale substanțelor

$X_{N_2} = 0,2018$ $X_{H_2} = 0,6055$ $X_{NH_3} = 0,1927$

K depinde doar de temperatură

$K = 0,00002$
 $K_x = 0,828$
 P K_x depinde de ambii parametri de stare

Reactor

Modificarea presiunii

Modificarea temperaturii

6600 K

100 300

500 700

(b)

Figure 11. Information presented in a transparent layer (b) which overlaps the main content (a).

Error prevention is also a good usability practice. According to specialized studies, errors lead to loss of credibility in multimedia applications. Thus, such a design is required so that it predicts all possible states that can be triggered by the user. Unlikely or strange situations should also be considered. Unfortunately this task is even harder to accomplish when there are several user input parameters. We have faced such a situation in the project I, with an

application that simulates a titration (figure 12). The relatively large number of parameters to be decided by the user, along with the drivers and complex mathematical models behind the simulation, lead to configurations in which the simulation could give errors. We have adopted a solution that has proven very effective, namely, we designed a sequential progress, wizard-type, where required parameters are introduced in several steps, each step being somewhat influenced by the decisions made in the previous one. For instance, titrant and titrated species can be chosen only at step 2, from a list filtered by the option made at step 1, by the choice of type of titration. Thus, the temporal split of application may have consequences in the delimitation of those elements, whose combinations represent sources of errors.

Multimedia content developers must strive for simplicity in layout, screen function, structural design and other program elements. Complex or extraneous interface elements unnecessarily burden users' working memory.



Figure 12. Wizard-type multimedia application

4. Content development: Examples

Since 2004, higher education in Romania has been undergoing substantial changes, in order to achieve the highest possible efficiency in developing adequate skills for young graduates, skills essential for their employability. The content development for the e-learning system in the faculty of Applied Chemistry and Materials Science followed the relation between technology and pedagogy, as presented in the previous section.

A first attempt to know the preferences of our students was by carrying out a survey on a 237 people sample [9]. This survey revealed the position of different categories of students:

undergraduates, aged 18 – 22, and postgraduate students, studying for a masters' degree, aged 24 – 55. In the mature students category there was a special lot formed by educators involved in primary and high school education; they were enrolled in a complementary-type continuing education master program and showed rather similar opinions in connection to the main educational issues.

The dominant feeling among the student population is that computer aided instruction is very useful in modern pedagogy for all teaching levels, higher education included. As regards the direct link between the technology and pedagogy, 93 % of the students agree that pedagogy should be defined according to the chosen technology. It is interesting to note that all participating mature students have expressed their preference for the constructivist approach, while half of the undergraduates (41 people) declared to be happier with an instructivist education style.

A group of enthusiastic students was identified, adopting e-learning to match their constructivist preference for the educational process. There is a second group using gladly technology, but preferring a classical pedagogical approach. A third group is satisfied by a constructivist approach in face-to-face educational activities, but does not see the advantage of using any ICT tools. Finally, a fourth group still does not acknowledge the potential of using e-learning as an interactive tool for teaching and learning, and therefore show deliberately no interest in testing computer aided instruction - CAI (figure 13).

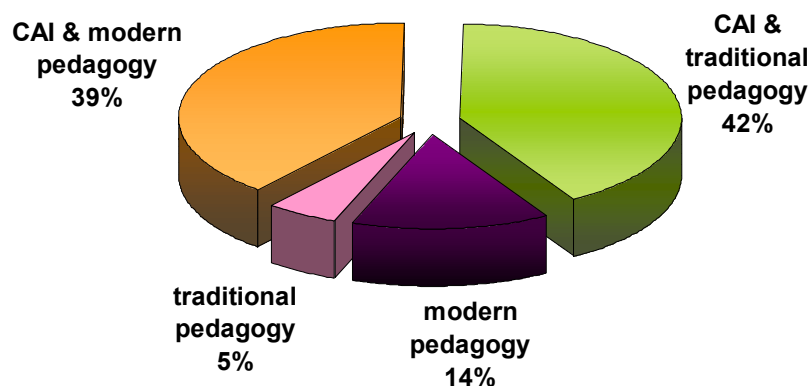

Figure 13. Students' pedagogical options for the educational process

In addition to the different requirements of various learning tasks, the students identified other variables likely to influence learning success: learner's experience for the subject in question, background knowledge, learning preferences ("learning style/cognitive style/thinking style") and orientation, including his or her reaction towards technology, learner's sensory pathways and cognitive processing abilities, emotional state, gender and age differences, cultural / corporate / institutional / societal requirements and values, presence or absence of collaboration with other learners, learning environment, including "learning distracters", availability of human and technological resources, and whether an individual or a group is being taught to (figures 14 and 15).

The content development in the e-learning system implemented in the faculty of Applied Chemistry and Materials Science followed an ascending route starting with the creation of

content delivery modules for faculty application consisting of lectures presented as power point presentations, including animations and links to videos concerning the topic in view (dedicated to instructivist teaching approach), simulated interactive laboratory experiments for all major subjects, and knowledge evaluation tests. These were included in the “Library” module of the e-learning platform and were accessible in the class, assisting the teaching staff in delivering vivid lectures, or they could be accessed by each student that had access to the platform on his/her own computer [10]. The industrial chemistry curriculum has a certain characteristic that makes it different from other technical courses: the higher amount of shared knowledge between different disciplines. As mentioned in the literature [11, 12], the classical teaching methods often fail in achieving the required fluidity between the curriculum subjects. By nature, an e-learning system allows modules from different disciplines to connect, and furthermore, to interact [13].

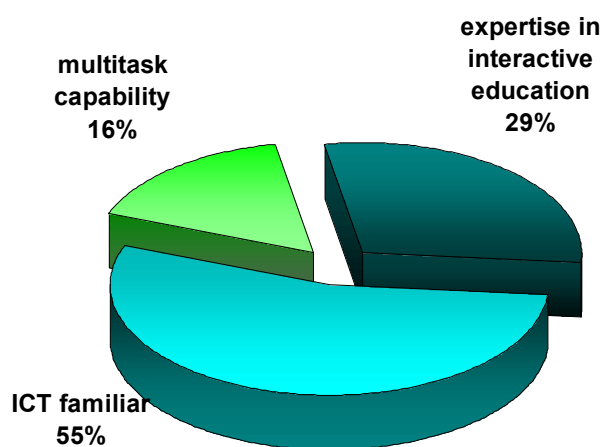

Figure 14. Required skills when using ITC technology.

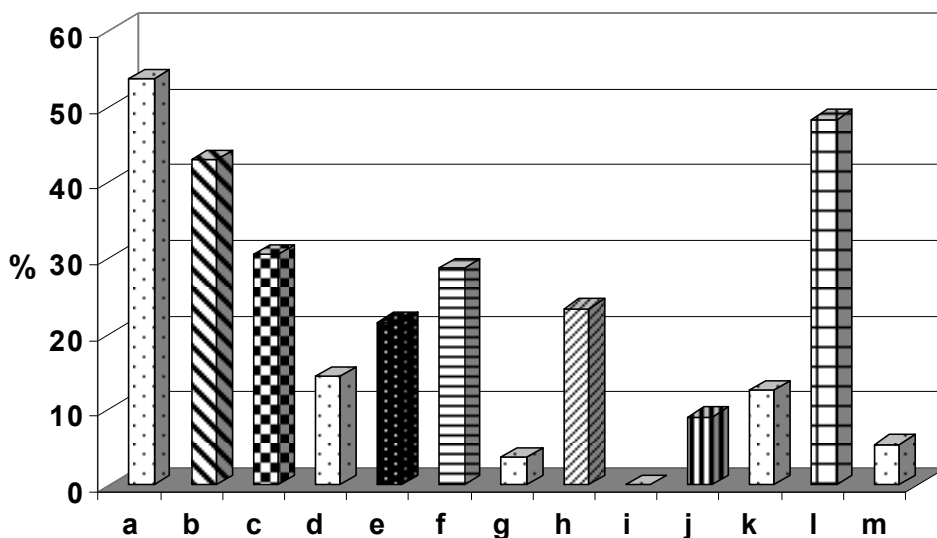

Figure 15. Main variables important for learners

(a -experience in the subject; b - background knowledge; c-learning preferences; d-learning reaction towards technology; e - sensory pathways; f - cognitive processing abilities; g - emotional state; h - age differences; i - gender differences, j – cultural/ corporate /institutional societal values; k - collaboration with other learners; l - learning environment; m – none)

In the same time, an exceptional effort was done to design and implement complex chemistry lessons for the e-learning community created within the collaborative project “**WE LOOK TOWARDS THE FUTURE-Professional Training of the Teaching Staff for Using Modern Digital Resources in Efficiently Teaching Chemistry**”, developed in the frame of the European Social Fund - SOP HRD 2007-2013, SOP HRD 61839. This project (referred to in the contribution as project I) had the following main objectives:

- development of ITC skills for teachers who teach chemistry and technology-related subjects in the K12 system,
- design of pilot ICT instruments suitable for transferring chemical knowledge,
- promoting on-line learning techniques in the K12 system,
- building-up a collaborative virtual community spread across Romania.

Face-to-face sessions with on-line and off-line activities have been designed and specially tailored digital educational resources for the K12 system have been implemented. Digital lectures and virtual laboratory experiments have been created for all main fields in chemistry (Inorganic, Organic, Analytical and Physical Chemistry). In order to improve the way chemistry is seen by high school students the project aimed to ensure: a relevant chemistry education philosophy, an optimized curriculum, and appropriate teaching approaches in chemistry by using ICT tools. Relevant assessment and evaluation strategies and relevant professional development for teachers have been also considered. The project also creates a collaborative virtual network between the chemistry teachers involved in the project which will be a good start for future collaborations.

As concerns the chemical engineering education in the faculty of Applied Chemistry and Materials Science, an important number of subjects such as analytical chemistry, chemical engineering bases, unit operations in chemical engineering, computer programming used the e-learning platform for teaching, and examination in a blend of assisted (virtual classroom) and non-assisted (virtual library) training sessions. Some examples are given bellow.

Figure 16 represents an aspect of some unit operation lecture included in the library of the e-learning system. As figure 16 shows, on the same slide students can see the main equations governing the design of a distillation column, the representation of vapour and liquid streams in the column and graphical solution for the calculation of the number of stages.

Figure 17 presents a moment from an Analytical Chemistry lesson, where the main steps in choosing the titration agent are explained. For each step links to further details are provided. Figure 18 presents an application for an interactive seminar session where students are asked to study a two-stage vapour compression refrigeration system. The application allows to choose the refrigerant, the suitable temperature ranges and to follow the fluid transformation in an enthalpy-pressure diagram.

In higher education chemistry laboratories, the practical experience is essential for students to increase their analytical skills and understanding of chemical concepts.

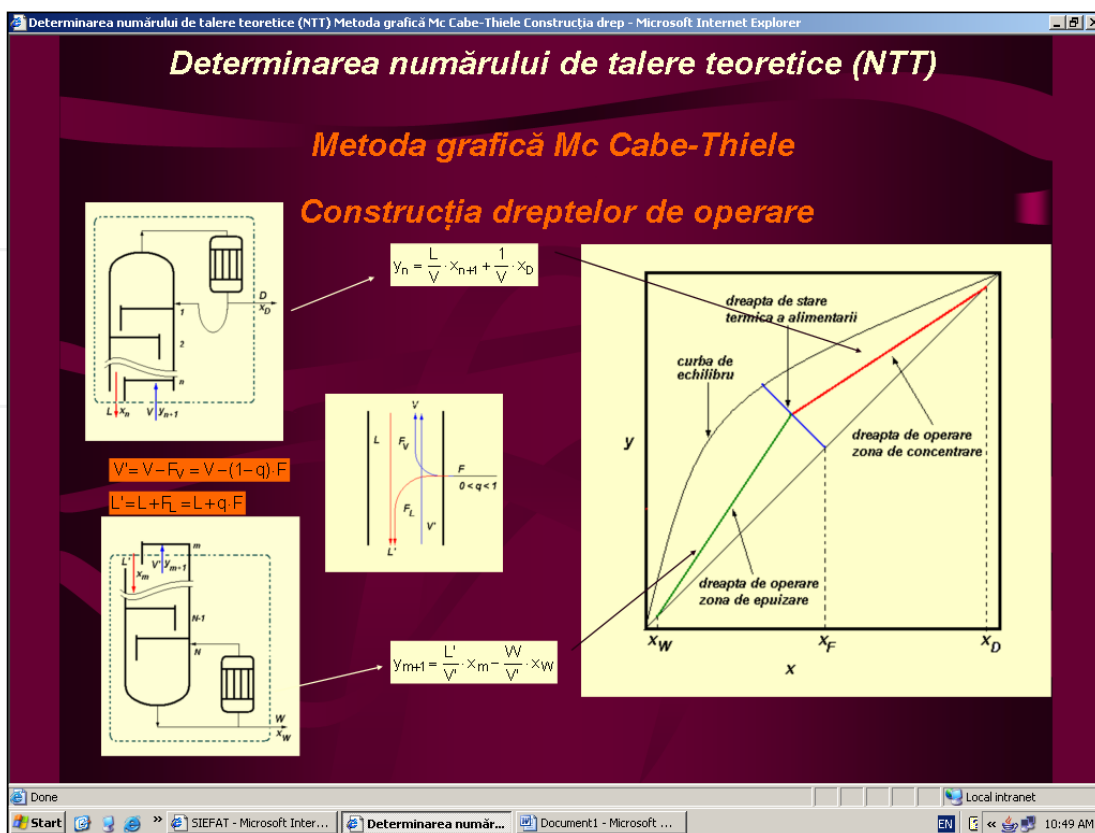

Figure 16. Design of a distillation column: Lecture in e-learning platform

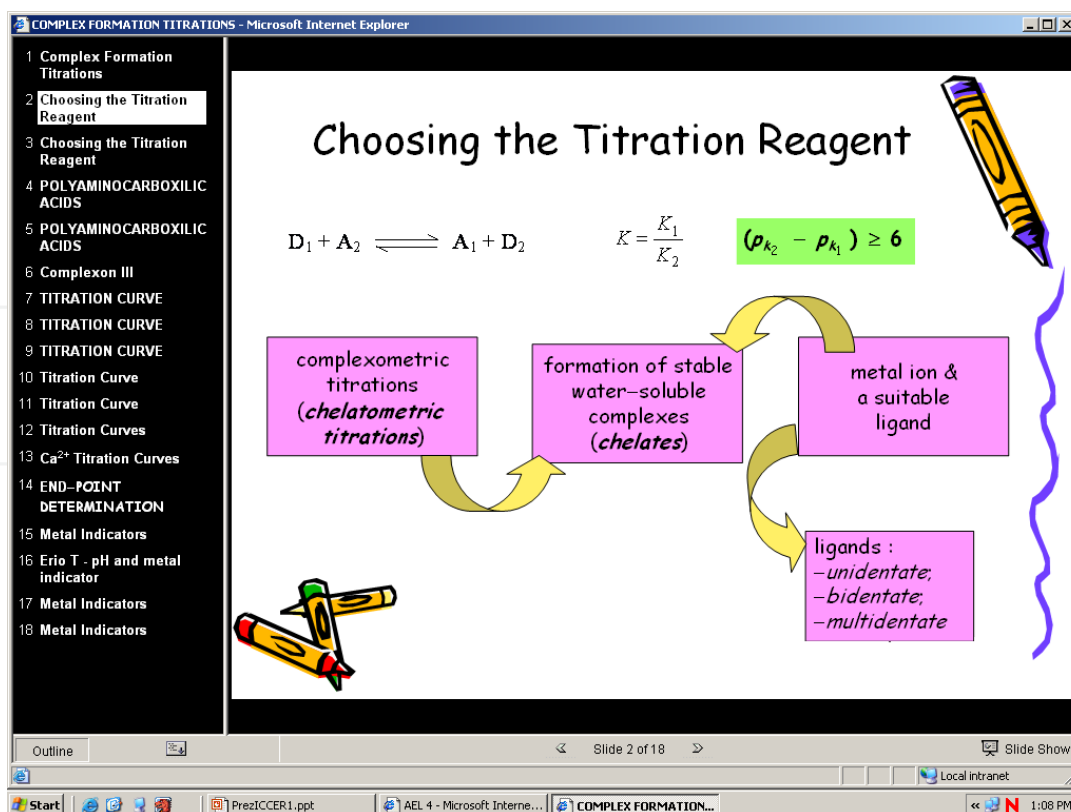

Figure 17. Analytical Chemistry lesson implemented in the library module.

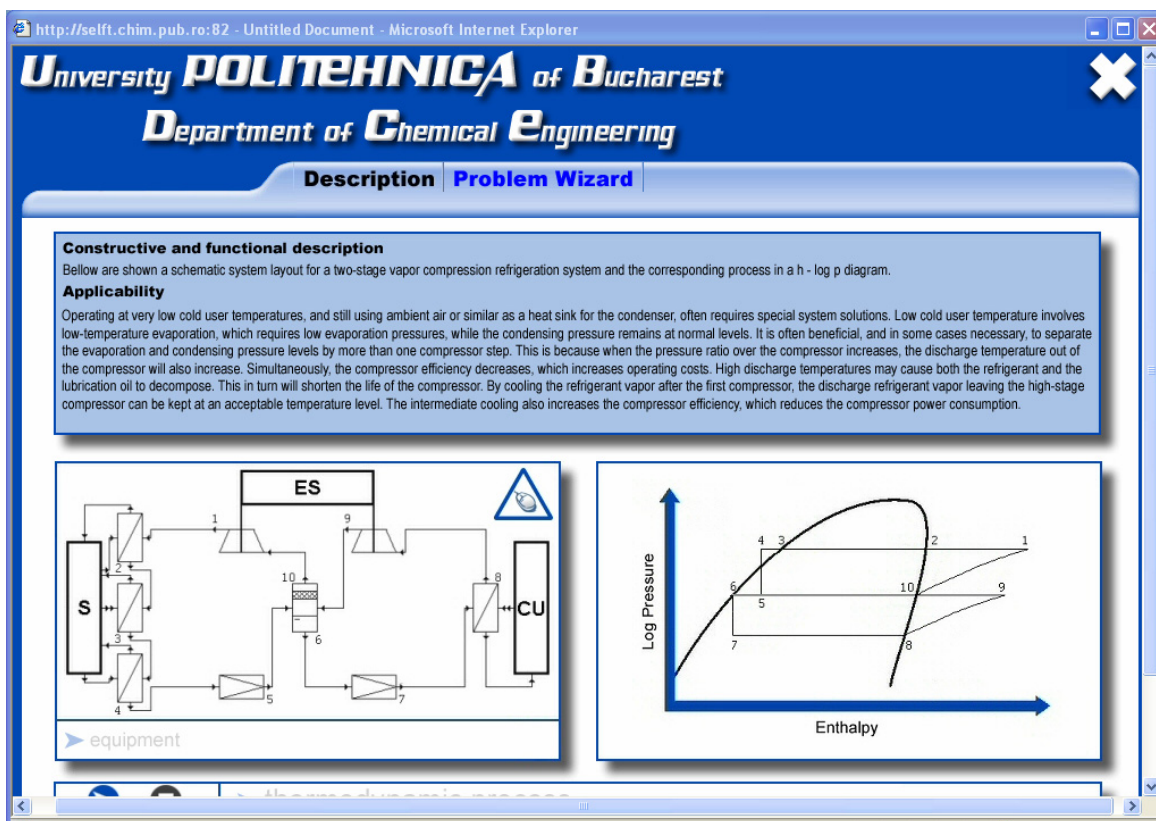

Figure 18. Vapour compression refrigeration system

The necessity to follow strict directions are factors of limited time, large numbers of students, cost restrictions, and the need to ensure the safety of all students in the laboratory. Laboratories should not only provide students with the opportunity to increase their analytical skills, but also to actively engage in practical activities while learning. One alternative to the traditional laboratory are virtual and remote labs, which can provide an interactive learning environment and connections to real world scenarios. Virtual laboratories should be used in conjunction with traditional laboratories. Virtual laboratories can be used as pre-lab to traditional laboratories, follow-ups for further exploration, or as substitute to traditional labs every now and then.

Virtual laboratories have been designed for both higher education and high-schools need. An example is a complex analytical chemistry experiment where students have to study the absorbance of a given indicator using the spectrophotometric analysis (figure 19). After a brief theoretical presentation (figures 19 a, and b) a new window is opened when the multimedia application button is activated. This window presents the laboratory equipment necessary for preparing buffer solutions of different pH values. The samples are prepared in Berzelius vessels using two burettes from two distinct solutions: citric acid and diacidic sodium phosphate (Figure 19 c); then different indicator solution at given pH values are obtained by mixing buffer and fixed indicator volume, while a final pH measurement is carried out (figures 19 d, and e). Figure 19 f presents the absorption spectrum of each solution obtained with the aid of a virtual spectrophotometer and the registration of the absorbance value. When the sample is analysed, a pop-up window opens to show the

spectrum, and, when selecting the red dot indicating the maximum absorption, the value is registered in the table (Figure 19 g). Finally, the calculation can be done according to the sheet that is provided by the application (Figure 19 h). As figure 19 shows, all principles of usability applied to a navigational system of a multimedia instruction system (as presented in section 2) are applied: indication of the place in the system, instruction to use the application (up left corner), pup-up buttons (figure 19 b).

Apart from simulated laboratory experiments, a **remote laboratory module** was implemented in the e-learning system in the University 'Politehnica' of Bucharest [14]. This approach has both advantages and disadvantages. In the advantages category one should mention: provision of laboratory experience to on-campus students, as well as to distance learning students, more efficient use of premises and equipment, design of laboratory pilots matching closer the industrial reality, and increased responsibility of the student user when operating the available equipment.

As for drawbacks, the list includes consistent acquisition, implementation, and running (consumables, staff, energy) costs, and the development of on-line communication and security tools for continuous supervision of on- and off-campus students.

The remote laboratory module is based on an in-house developed robot consisting of a central processing unit, mechanical set-up for sample and sensors handling incorporating a stable frame, revolving disc, and a miniature step-by-step engine, and flexible sensor arms, chemical sensors, and the communication interface with the portal.

The graphical integration at level of workspace and teaching/learning space is defined for the two actors: teacher and student.

The teacher can create courses (embedding the theoretical parts of the experiment), schedule courses, add participants, and initiate the laboratory (sensors, solutions). The student can access the course assigned in the learning space, study the experiment theoretical issues, and finally perform the experiment.

The remote laboratory module can be accessed from the e-learning portal. The professor creates a course in the system and adds objects to the courses (Figure 20). Figure 21 presents the remote laboratory general structure.

The next major moment in education is implementation of computers, not only for teaching, finding information or solving complex calculus, but also for testing purposes. The creation and implementation of evaluation test grids was an important step in the development of our e-learning systems [15]. This already-not-so-new form of examination arises for both reducing-time and increasing-objectivity purposes (a written test contains now *many little problems*, instead of *few big problems*, and could be marked in real time). To avoid repetition, which leads the students to learn the grid instead of studying the course, the test grids should be *refreshed* from time to time.

The technical schools were the last to adopt this form of examination, mainly because it seems very unsuitable for this area. Usually, a test grid is composed from several *short questions*, each of them having a few given, alternative, and *exclusive* answers. This manner is perfect to test

Studiul spectrofotometric al indicatorilor
Aspecte teoretice

Chimie Analitică

Scopul lucrării: determinarea constantei de aciditate a unui indicator acidobazic de culoare, folosind proprietățile sale absorbante în domeniul vizibil.

Aspecte teoretice: Fenol sulfonftaleina, cunoscută și sub numele roșu de fenol, este un indicator acido-bazic, având formula $C_{19}H_{14}O_5S$. Aceasta își schimbă culoarea în funcție de pH-ul soluției, ca urmare a următoarelor echilibr succesive de disociere:

$$\begin{aligned}
 & \text{HIn} + \text{H}_2\text{O} \rightleftharpoons \text{HIn}^+ + \text{OH}^- \quad (1) \\
 & \text{HIn} + \text{H}_2\text{O} \rightleftharpoons \text{In}^- + \text{H}_3\text{O}^+ \quad (2)
 \end{aligned}$$

(a)

Studiul spectrofotometric al indicatorilor
Aspecte teoretice

Spectrele din figura următoare, obținute pentru soluții de indicator acido-bazic (pH 12,3) se intersectează la 480 nm, formând o valoare absorbantei rămâne constantă pentru toate spectrele, absorbante rămâne constantă. Puncte isoabsorbante apar în soluții de vedere stoichiometric sau aflate în echilibru, proporțiile lor de component, cum ar fi concentrația ionilor hidroniu, H_3O^+ .

Vizualizează graficul

Figura 1. Familia de spectre de absorbție înregistrate pentru roșu de fenol (10^{-5}M) în soluții tamponate de pH 6,8 - 8,2 și în mediu puternic bazic (NaOH , $2 \times 10^{-2}\text{M}$, pH 12,3).

(b)

Studiul spectrofotometric al indicatorilor
Experiment

Selecționați cantitatea de fosfat disodic dorită și apoi faceți click pe robinetul biuretei.

(c)

Folosiți pipeta 6 pentru a transfera 10 mL soluție tampon din paharul Berzelius cu nr.6.

(d)

Folosiți pH-metrul pentru a măsura pH-ul soluției din balonul cotat nr.4.

Notăți valoarea pH-ului soluțiilor din fiecare balon cotat.

(e)

Umpleți cuva cu soluție din balonul cotat nr.2.

(f)

Studiul spectrofotometric al indicatorilor
Experiment

Citiți și notați valoarea absorbantei la 558 nm (dublu-click). Axa Ox se modifică pentru a arăta: Lungimea de undă, nm.

pH	$A_{558}^{10^{-5}}$
6,8	0,442
7,0	0,386
7,2	
7,4	
7,8	
8,2	
12,3	

(g)

Datele obținute din măsurările spectrometrice experimentale la lungime de undă fixă (558 nm) se colectează într-un tabel de forma tabelului 2, unde se raportează valorile absorbantelor măsurate cu 3 cifre semnificative. Completați toate rubricile tabelului 2, folosind pachetul software Excel. Rezultatele obținute se raportează în tabelul 2.

Tabel 2. Prelucrare date experimentale.

pH	$A_{558}^{10^{-5}}$	$\log \frac{[\text{In}^-]}{[\text{In}^+]}$ = $\log \frac{A_{558}^{10^{-5}}}{A_{12,3}^{10^{-5}} A_{558}^{10^{-5}}}$	$\log K_{\text{InH}^+/\text{In}^-}$ = $\log \frac{A_{558}^{10^{-5}}}{A_{12,3}^{10^{-5}} - A_{558}^{10^{-5}}} - \text{pH}$
6,8			
7,0			
7,2			
7,4			
7,8			
8,2			
pH	$A_{12,3}^{10^{-5}}$		
12,3			

(h)

Figure 19. Spectrophotometric study of pH indicators

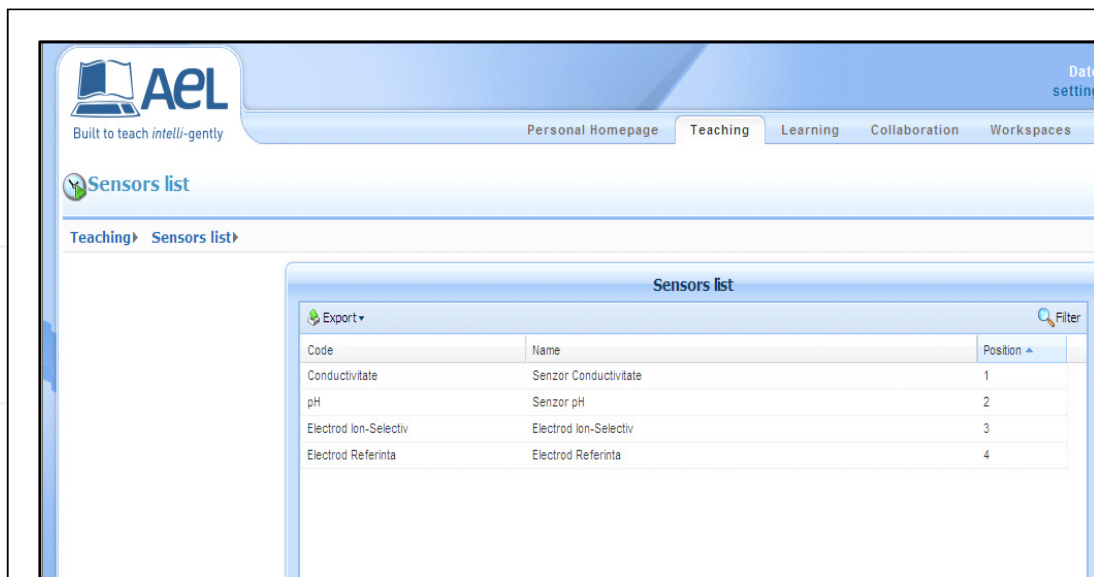

Figure 20. Adding sensors from the sensors list

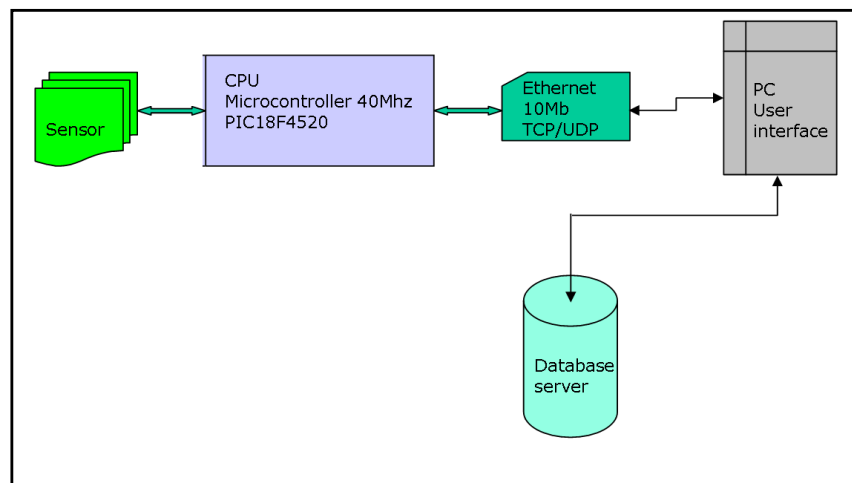

Figure 21. Remote laboratory structure

acquired information, such as geographic or historic data. Using an evaluation test grid for technical purposes means was avoiding some ridiculous situations like the following:

“Solve the given cubic equation and find its solutions: $x^3 + 9.4 \cdot x^2 - 17.12 \cdot x + 5.28 = 0$.

- 1.2; - 11; 0.4;
- 1; 0; - 1;
- i; 0; - i;
- 1.2; 11; 0.4;
- 1.2; - 11; - 0.4”.

It is obvious that no abilities to *solve* high degree equations are tested here, since the candidate has nothing else to do but to *replace* the given values and check if they are real solutions. Although a test grid like this is usually called “with multiple choices”, very often only *one* choice is true!

It is obvious that this kind of test grid is not suitable for technical purposes. But, with adequate reformulation the above example could be easily changed so that the student has to really solve the equation and, moreover, to test other connected abilities:

“For the cubic equation $x^3 + 9.4 \cdot x^2 - 17.12 \cdot x + 5.28 = 0$, please check the *false* answers:

- a. all solutions are imaginary;
- b. all solutions are real and positive;
- c. all real solutions are positive;
- d. the absolute value of some real solutions is above unity;
- e. the imaginary part of one solution is i ;
- f. there are no real solution less than -10 ;
- g. there are opposite real solutions;
- h. there is at least one null solution;...”

Now the equation should be *really* solved, although first two points could be prior checked, while there is always at least one real solution for a third degree equation and, from inspection of the positive free term, it yields that at least one negative solution arises (it represents the inverse product of all three solutions). In this manner, someone who doesn't know the formula or being in time-crisis (at the end of allocated time) could check something, but all requirements are fulfilled only by solving the equation. While several good answers could be expected, consequently a more refined evaluation is possible – if a student had checked only part of the correct alternatives, perhaps some fraction of the attached points should be given. The major disadvantage of all test grids may be real only with bad composed / organized test grids.

“For the given cubic equation $x^3 + (7.8 + 0.1 \cdot N) \cdot x^2 - 17.12 \cdot x + 5.28 = 0$, please...”

In this manner, one can have at the same time and in the same classroom up to 31 students solving the same problem, but with slightly different data. Also, a small database containing the given number for each student will allow repeating the test and get a different integer that will be assigned using a small program. In order to correct these slightly different problems, the instructor should solve them all, but this is not such a big obstacle while a lot of matrix-oriented solvers are available (Excel, Mathcad, MATLAB). Even the double-checking and the point attribution could be carried out with an algorithm and a developed code.

An example of test grid implemented in the faculty e-learning platform for the final examination in “Chemical Engineering Bases” is given bellow. Each student receives three files in his directory, one containing the application text, where some data are given as functions of the number N (the exam number, which customizes the problems) (figure 22). Also, instructions to solve the problems are given in a separate file, while the third one contains an empty table to be filled by student only with his results (figure 23). This is another innovation: we are no longer interested in how the student works to solve the problem, since same type problems were already solved during the semester – our philosophy here is that perhaps two or three methods are appropriate to solve and at least

one hundred various mistakes could happen, so there no “prizes” only for applying an appropriate formula to get a wrong answer.

A well mixed vessel with a volume of $V=5 \text{ m}^3$, contains $m_0=(1000+100 \times N)$ Kg of an aqueous solution of a salt, A, having the initial concentration $w_{A,0}=0,15$ (mass fraction). The vessel has an overflow and a bottom drain connection. At a given moment, the vessel is fed at constant flowrate, $G_{m,i}=(5-0.15 \times N)$ kg/s with salt concentration of $w_{A,i}=0.3-0.01 \times N$. After 10 min, the liquid in the vessel begins to be evacuated by the bottom drain with constant flowrate $G_{m,e}=10$ kg/s.

1. What is the maximum quantity of solution in the vessel?
2. What is the corresponding salt concentration when the maximum quantity of solution is in the vessel?
3. Calculate the required time to evacuate all the liquid in the vessel (min).
4. What is the salt concentration in the vessel after 15 min from the beginning of the experiment.

Note: The density of the solution is considered to be 1000 kg/m^3 whatever the value of the salt concentration.

Figure 22. A personalized numerical evaluation test containing the parameter N).

A good engineer should supply the *approximate* good answer in a limited time, no matter the method. The table supplied is an Excel sheet, protected to receive only figures in some cells, and perhaps with imposed measure units in others. This type of table is very easy to be collected and passed through a validation algorithm, were some intervals are checked against written numbers (i.e., there are accepted solutions having small deviations like $\pm 5\%$, of course if this is not *aberrant*).

Results double-check against a “teacher’s table of truth”, containing already solved applications for all numbers N, like in figure 24 (this time, a Mathcad sheet) were also provided.

	A	B	C	D
1		N =		
2	Literal code	Subitem number	Numerical value	Measure units
3				
4				
5				
6				
7				
8				
9				
10				
11				
12				
13				
14				

Figure 23. Answering table for problems

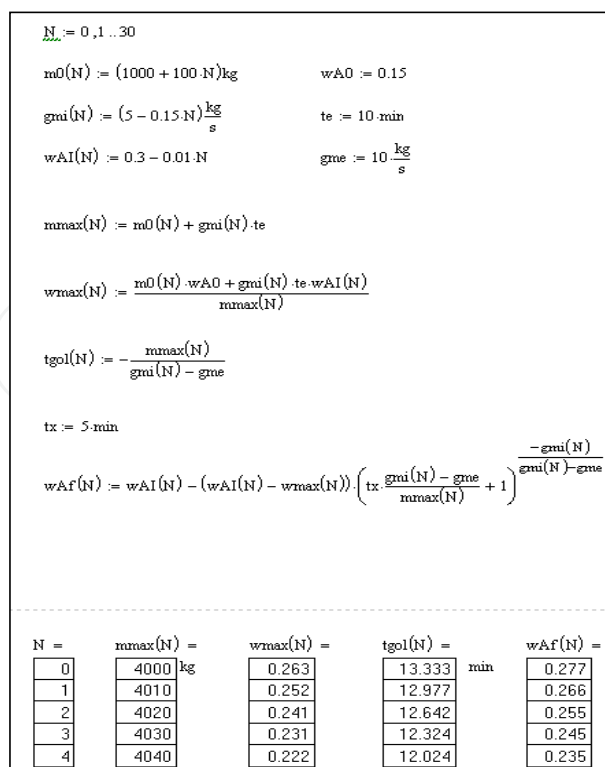

Figure 24. Solutions for parametrical problem

Next stage of an on-line examination is the *theoretical test grid*. When the test grid is prepared, other innovations may be used. First, the whole taught material is divided into “slices”, say *subjects* (for example, several subjects could arise from each lecture – they are like paragraphs in the book). Next, the *text* for every subject should be formulated as generally as possible (and yet, very brief, for example, “Identify true / false statements”, “check the correct / wrong answers”, etc.). Then, for each subject, a small database containing a large number of options, either true or false, is constructed. The number could be increased from time to time, and also each variant could be modified if necessary. For example, from chapter 2 of a given course, six subjects can be formulated, numbered 5 to 10, each one having more than 10 answers (at least one is true and/or one is false). Usually, there is almost the same number of true and false alternatives. The central point is how to construct a test grid from this database, in order to be both *complete* and *new*, even for students who re-sit the examination? This can be done using a *selection* algorithm, which is instructed to randomly choose an established number of subjects from each chapter. In the given example, there will be 2 subjects, of any combination of numbers between 5 and 10. At the lower level, the algorithm will randomly select a given number of variants (say 5 or 6) from the given database; the *order* (i.e., the position in the list, denoted by small letters, from **a** to **e**) could differ, the only constraint being to have at least one true and one false answer. Tests are automatically generated in this manner, and they have a different content, customized for each candidate. Also, a variable solving time could be used, to adjust to the difficulty.

Figure 25 presents some theoretical test-grids implemented in the faculty e-learning system.

(50) Item 50

Punctaj: 1 Timp: 1 minute Obiectiv:

Enunțul problemei:
The picture presents

a close-up of the electrified interface, when an electrode is dipped into an electrolyte solution, in the absence of any imposed voltage
 the structure of the Nernst diffusion layer in a still system
 the magnified picture of an electrochemical cell
 a reference electrode
 none of the above

(15) Item 15

Score: 1 Time: 1 minute(s) Objective:

Question text:
When titrating a strong acid with a strong base, the equivalence pH should be

acidic, calculated with the formula

$$pH = -\lg c - \lg \frac{100 - n}{100 + n}$$

basic, calculated with the formula

$$pH = 14 + \lg c + \lg \frac{n'}{2V_1 + n'}$$

neutral, calculated with the formula

$$pH = \frac{pK_{a_1} + pK_{a_2}}{2}$$

slightly basic, calculated with the formula

$$pH = -\lg c - \lg \frac{n'}{2V_1 + n'}$$

none of the above

Figure 25. Evaluation grid test in analytical chemistry examination.

As concerning specific content development for high school education, applications were created in order to make more attractive all basic chemistry knowledge, such as the periodic table of elements, the chemical bonds, physical and chemical properties of elements and compounds. Some more complex lessons were also designed in order to increase the interest of young people towards practical applications of chemistry in various technical fields and environment protection. As research has shown, chemistry teaching is unpopular and irrelevant in the eyes of students, does not promote higher order cognitive skills, leads to gaps between the students' wishes and teachers' teaching and, most important, is not changing, because teachers are afraid of change and need guidance [16]. The usage of vivid lessons involving ICT tools is expected to increase the interest towards chemistry in Romanian high schools.

The content implemented in the e-learning platform as an aid for high school chemistry education is designed according to the pedagogy-technology relationship presented earlier, in order to be easy to access and attractive. Some examples are given in the followings, to illustrate all domains in which interactive lessons are available.

Figure 26 shows how chemical bonds are explained in an inorganic chemistry class. As figure 26 shows, two atoms with unpaired electrons (a) can create double or triple bounds (b) that are represented in a schematic manner as figured in (c).

Figure 27 is a moment from an inorganic chemistry lesson where the dissolution of an ionic salt in polar solvents (water) is explained. On the left side of the screen some theoretical explanation is given. On the left it is shown how water, that is pored over solid NaCl crystal, acts upon the ions in the crystalline structure, displacing ions, and, finally, both chloride and sodium ions move freely in solution.

Another example is the presentation of a simple experimental device to calculate the capacity of an accumulator. This is implemented as interactive lesson for high school students in the XIth grade. The experimental set-up must be built by using its elements (Figure 28 a). The application allows only the use of the correct positions for each element in the predefined scheme. When the experimental setup is ready, the experiment may start and the results are registered automatically (Figure 28 b), until the accumulator is totally discharged (Figure 28 c). Based on simulated experimental data the calculation sheet is provided (Figure 28 d).

Some easy to use virtual laboratories are designed for environmental protection lectures. Figures 29-31 present three moments of a virtual laboratory studying the evolution of two plants (begonia and philodendron) in water and simulated acid rain water.

Figure 29 corresponds to the initial moment, when all the four plants are full of life. When the "start" button, placed in the window down on the left side, is activated the simulation of plants evolution begins. After starting the application, the clock indicates the elapsed time and so does the calendar on the shelf. Figure 30 corresponds to the situation noticed after 4 days: the plants in water are flourishing, while those in simulated acid rain regress. After 6 days (Figure 31), the plants in simulated acid rain water are no more alive.

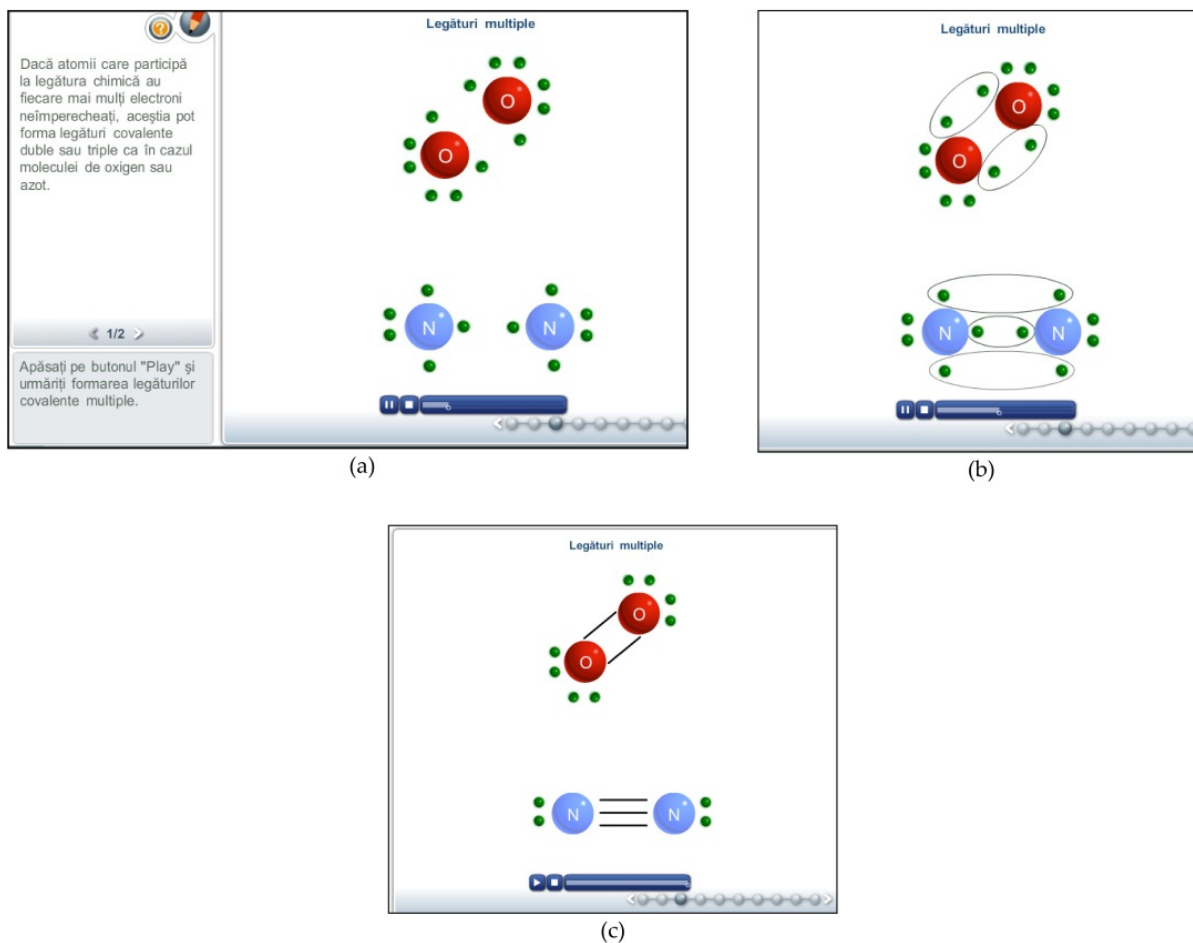

Figure 26. Animation used in teaching the formation of covalent bonds.

The figure shows two screenshots of a chemistry software interface. Both screenshots are titled "Chimie anorganică" and "Legătura chimică - Legătura ionică".

Left Screenshot: The main content area is titled "Proprietățile compușilor ionici" and "Proprietăți fizice". A sub-section "2. Solubilitatea" is highlighted. The text describes the physical properties of ionic compounds, stating they depend on the strength of the ionic bond and the crystal lattice structure. It notes that ionic compounds are generally solid, soluble in polar solvents, have high melting and boiling points, and conduct electricity when molten or dissolved, but not in the solid state. A diagram shows a crystal lattice of NaCl and a beaker of water (H₂O).

Right Screenshot: This screenshot is identical to the left one, showing the same text and diagrams. It includes a play button and navigation controls at the bottom.

Figure 27. Properties of ionic compounds

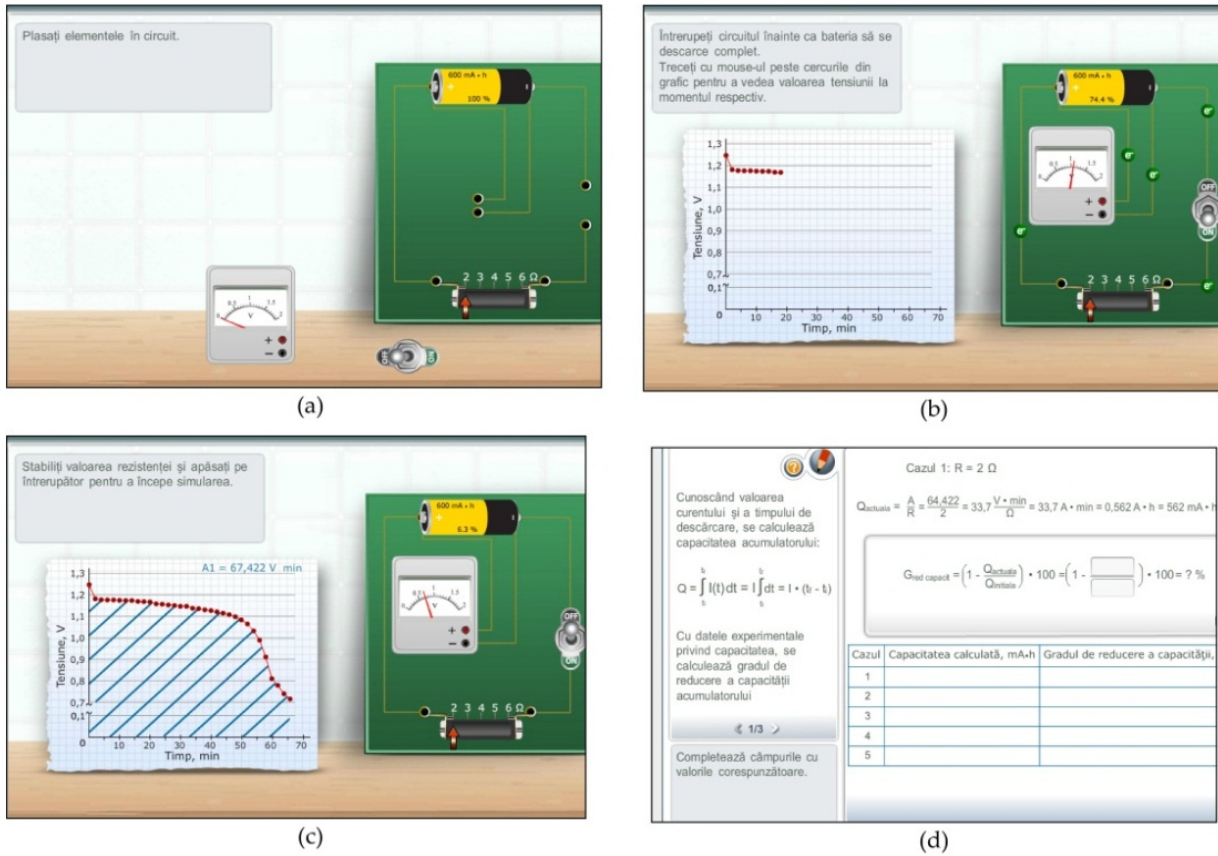

Figure 28. Virtual experimental to calculate the capacity of a Ni-Cd accumulator

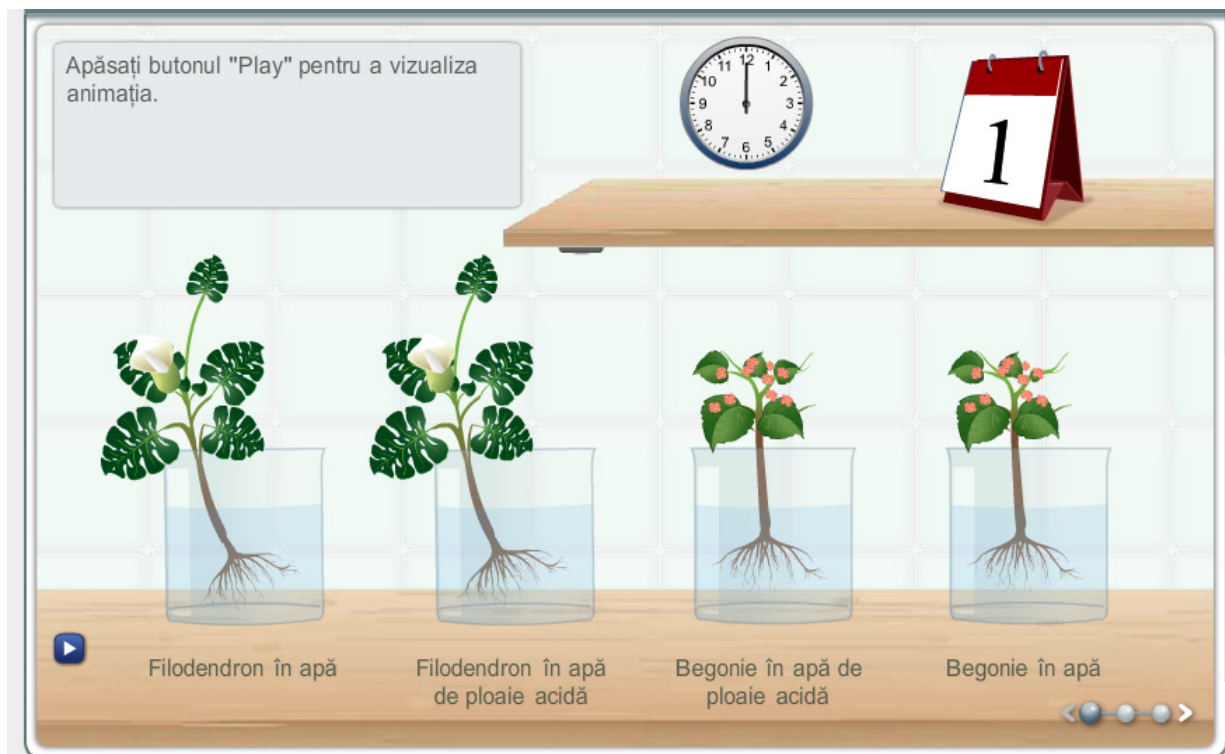

Figure 29. Environmental protection virtual laboratory-plants in water and simulated acid rain-initial moment

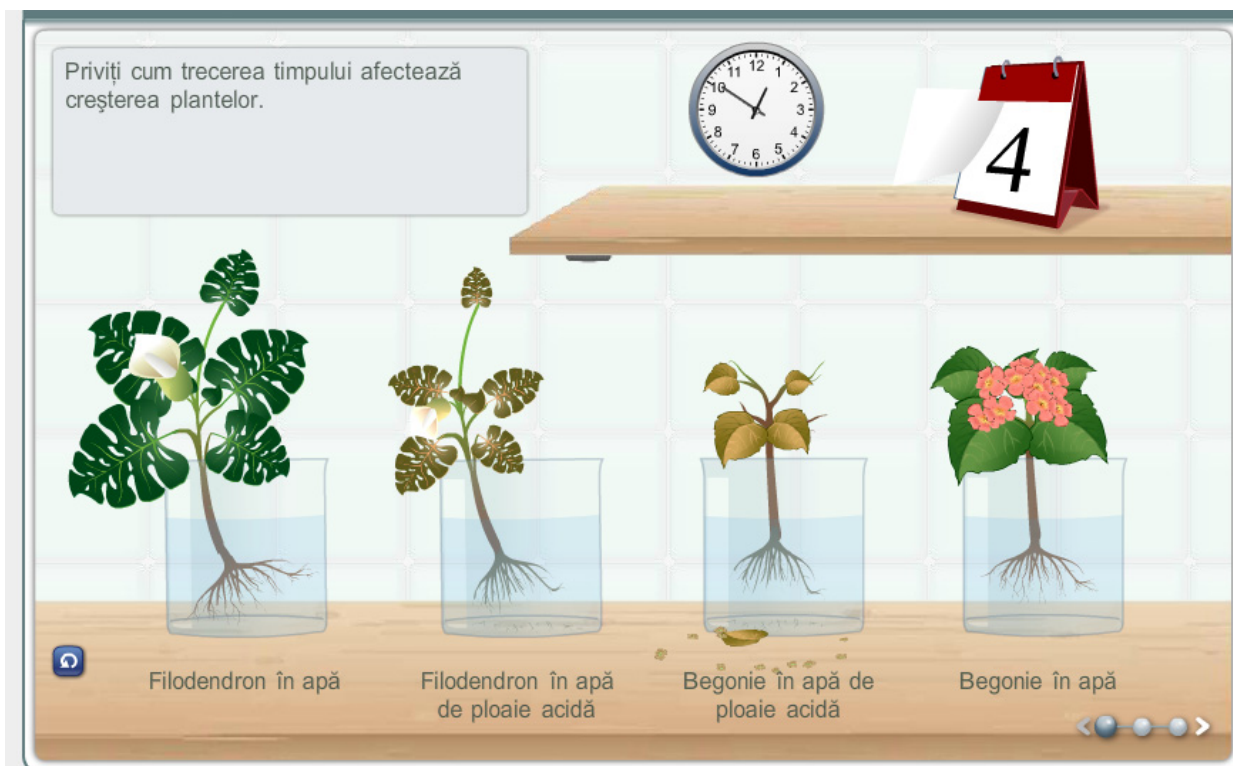

Figure 30. Environmental protection virtual laboratory-plants in water and simulated acid rain-after 4 days

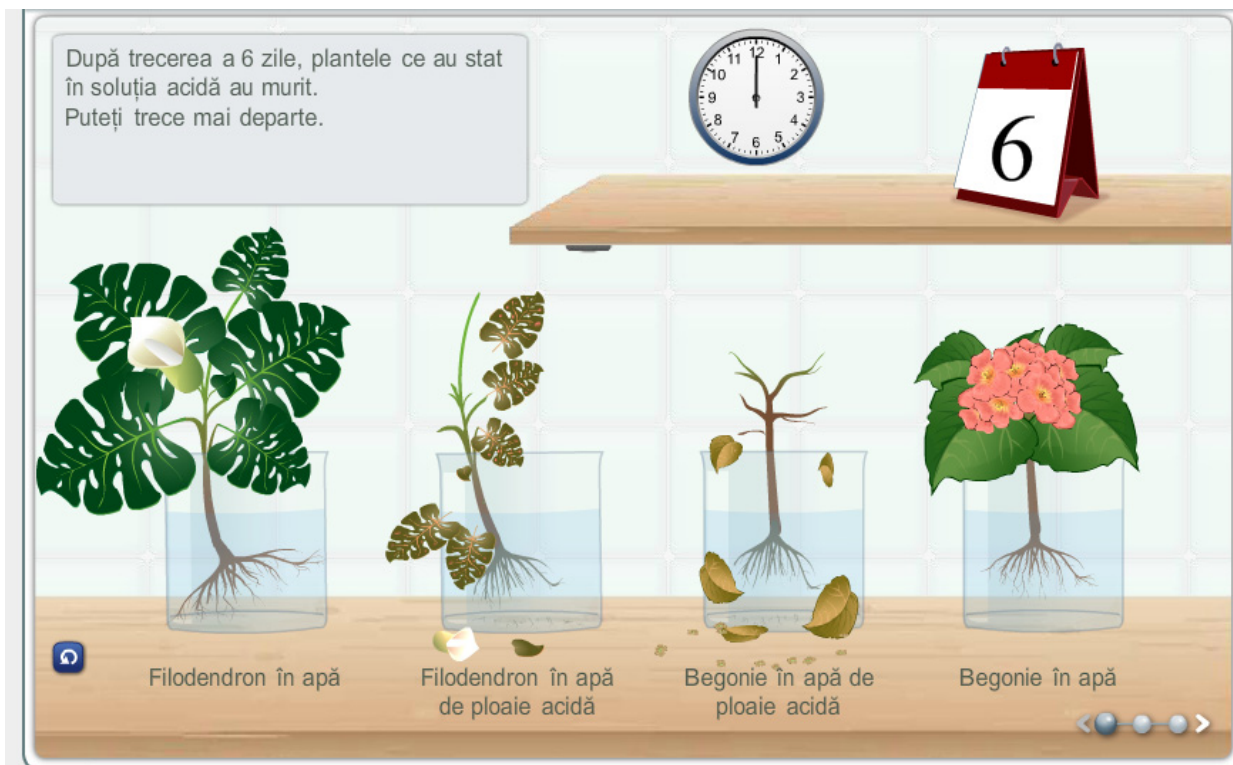

Figure 31. Environmental protection virtual laboratory-plants in water and simulated acid rain-after six days

5. Conclusions

The use of ITC tools in teaching chemistry and chemical engineering can help K12 and higher education students to understand theoretical concepts easier and make chemistry a more attractive subject. The experience gained over the time by part of the teaching staff in the Faculty of Applied Chemistry and Material Sciences in developing and delivering educational resources with the aid of ICT tools has been shared in the present chapter, giving enough evidence that computer aided instruction is a valid, modern pedagogical approach for high school and university educators, will lead to increasing quality of education, and represents a realistic strategy for convincing young people to approach jobs in science and engineering as a valid life perspective.

Author details

Ana Maria Josceanu, Raluca Daniela Isopescu,
Paula Postelnicescu, Anca Madalina Dumitrescu and Razvan Onofrei
Faculty of Applied Chemistry and Material Sciences, University Politehnica of Bucharest, District 1, Bucharest, Romania

6. References

- [1] Baltac V and Mihalca D (2007) On Romanian Experiences Related to Universities and ICT industry. 2nd IT STAR Workshop Universities and ICT Industry, Genzano.
- [2] Pearson J (2006) Investigating ICT Using Problem-Based Learning in Face-to Face and Online Learning Environments. *Computers & Education* 47: 56-73.
- [3] Josceanu A M, Isopescu R, Pleșu V, Zelch O (2006) Scorm-Based Content Delivery and e-Learning Platform for Chemical Engineering Education in University 'Politehnica' of Bucharest. PRES 2006, Prague.
- [4] Onofrei R, Josceanu A M, Postelnicescu P, Pleșu V (2005) e-Learning Interactivity Approach in Chemical Engineering Education. *Chemical Engineering Transactions* 7: 431-436.
- [5] Elshorbagy A and Schönwetter D (2001) Engineer Morphing: Bridging the Gap between Classroom Teaching and the Engineering Profession. *Int. J. Engng. Ed.* 3: 295-300.
- [6] Josceanu A M, Isopescu R, Postelnicescu P, Onofrei V, Plesu V (2007) E-Learning Support for Bologna-based Curricula for Chemical Engineering Education. *Chemical Engineering Transactions* 12: 561-566.
- [7] Josceanu A M, Isopescu R, Postelnicescu P, Dumitrescu A M, Plesu V, Zelch O, Stefan C (2008) Enhancing higher chemical engineering education and collaboration in the frame of an e-learning platform. PRES 2008, Prague, CD-ROM of full texts.
- [8] Josceanu A M, Postelnicescu P, Dumitrescu A, Danciu T (2008) Communication and collaboration in the frame of an e-learning platform in chemical engineering education. 9th European Conference E-COMM-LINE 2008, Bucharest, CD-ROM of full texts.

- [9] Josceanu A M, Dumitrescu A M, Danciu T, Isopescu R, Postelnicescu P, Pleșu V, Stefan C (2010) E-Learning Today. *Chemical Engineering Transactions* 21: 1057-1062.
- [10] Project no.1270/2006 Development of an advanced e-learning platform for higher education institutions.
- [11] McCowan J (2002) An Integrated and Comprehensive Approach to Engineering Curricula Part Two: Techniques. *Int. J. Enging. Ed.* 18: 638-643.
- [12] Wanks S (1995) Curriculum design. From an art towards a science. Berlin: Tempus Publications. pp 6.
- [13] Kartan N, Al-Reshaid K (2002) Design and Implementation of a Web-based Multimedia Techniques for Construction Education. *Int. J. Engng. Ed.* 4:682-691.
- [14] Josceanu A M, Postelnicescu P, Dumitrescu A M, Pleșu V, Stefan C (2009) Remote Control Experiments in Chemical Engineering Education, *Chemical Engineering Transactions* 18: 773-778.
- [15] Danciu T, Dumitrescu A M, Postelnicescu P, Josceanu A M (2009) Test Grids in Technical Universities. The 10th European Conference E-COMM-LINE 2009, Bucharest, CD-ROM of full texts.
- [16] Holbrook J (2005) Making Chemistry Teaching Relevant. *Chemical Education International* 6:1-12.