

We are IntechOpen, the world's leading publisher of Open Access books Built by scientists, for scientists

4,800

Open access books available

122,000

International authors and editors

135M

Downloads

Our authors are among the

154

Countries delivered to

TOP 1%

most cited scientists

12.2%

Contributors from top 500 universities



WEB OF SCIENCE™

Selection of our books indexed in the Book Citation Index
in Web of Science™ Core Collection (BKCI)

Interested in publishing with us?
Contact book.department@intechopen.com

Numbers displayed above are based on latest data collected.
For more information visit www.intechopen.com



Wind Turbine Generator Technologies

Wenping Cao, Ying Xie and Zheng Tan

Additional information is available at the end of the chapter

<http://dx.doi.org/10.5772/51780>

1. Introduction

Wind energy is playing a critical role in the establishment of an environmentally sustainable low carbon economy. This chapter presents an overview of wind turbine generator technologies and compares their advantages and drawbacks used for wind energy utilization. Traditionally, DC machines, synchronous machines and squirrel-cage induction machines have been used for small scale power generation. For medium and large wind turbines (WTs), the doubly-fed induction generator (DFIG) is currently the dominant technology while permanent-magnet (PM), switched reluctance (SR) and high temperature superconducting (HTS) generators are all extensively researched and developed over the years. In this chapter, the topologies and features of these machines are discussed with special attention given to their practical considerations involved in the design, control and operation. It is hoped that this chapter provides quick reference guidelines for developing wind turbine generation systems.

2. Utilization of wind energy

The utilization of wind energy can be dated back to 5000 B.C. when sail boats were propelled across the river Nile. It was recorded that from 200 B.C. onwards wind was used as an energy source to pump water, grind grain, and drive vehicles and ships in ancient China and Middle East. The first documented windmill was in a book *Pneumatics* written by Hero of Alexandria around the first century B.C. or the first century A.D. [52]. Effectively, these wind mills are used to convert kinetic energy into mechanical energy.

The use of wind energy to generate electricity first appeared in the late 19th century [35] but did not gain ground owing to the then dominance of steam turbines in electricity genera-

tion. The interest in wind energy was renewed in the mid-1970s following the oil crises and increased concerns over resource conservation. Initially, wind energy started to gain popularity in electricity generation to charge batteries [17] in remote power systems, residential scale power systems, isolated or island power systems, and utility networks. These wind turbines themselves are generally small (rated less than 100kW) but could be made up to a large wind farm (rated 5MW or so). It was until the early 1990s when wind projects really took off the ground, primarily driven by the governmental and industrial initiatives. It was also in 1990s there seemed a shift of focus from onshore to offshore development in major wind development countries, especially in Europe.

Offshore wind turbines were first proposed in Germany in 1930s and first installed in Sweden in 1991 and in Denmark in 1992. By July 2010, there were 2.4 GW of offshore wind turbines installed in Europe. Compared to onshore wind energy, offshore wind energy has some appealing attributes such as higher wind speeds, availability of larger sites for development, lower wind shear and lower intrinsic turbulence intensity. But the drawbacks are associated with harsh working conditions, high installation and maintenance costs. For offshore operation, major components should be marinated with additional anti-corrosion measures and de-humidification capacity [24]. In order to avoid unscheduled maintenance, they should also be equipped with fault-ride-through capacity to improve their reliability.

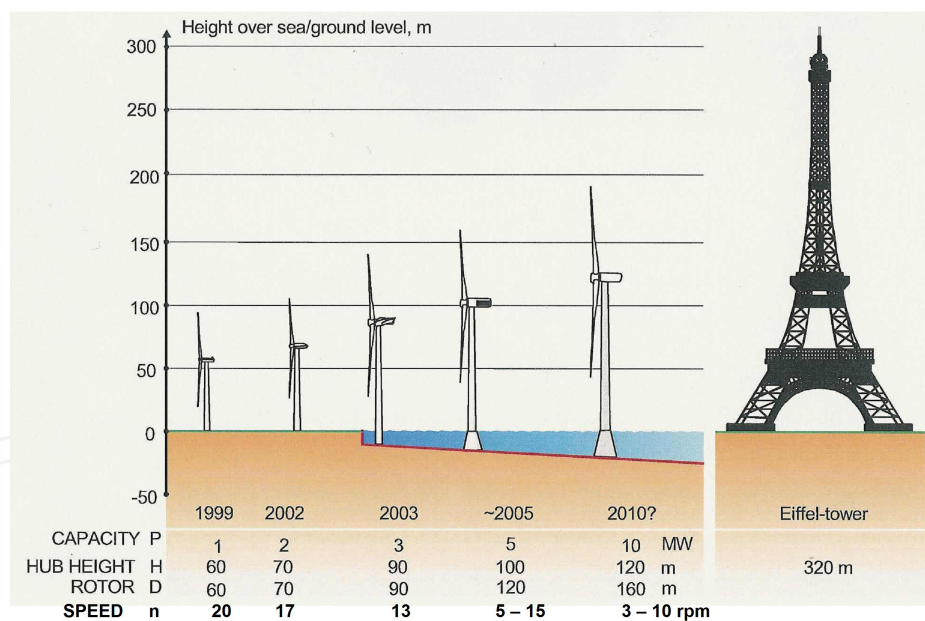

Figure 1. Ever-growing size of horizontal-axis wind turbines [36].

Over the last three decades, wind turbines have significantly evolved as the global wind market grows continuously and rapidly. By the end of 2009, the world capacity reached a total of 160 GW [7]. In the global electricity market, wind energy penetration is projected to rise from 1% in 2008 to 8% in 2035 [45]. This is achieved simply by developing larger wind turbines and employing more in the wind farm. In terms of the size, large wind turbines of

the MW order began to appear in the EU, the US and now in China and India. Typically, the large installed wind turbines in utility grids are between 1.5-5MW whilst 7.5 and 10 MW are under extensive development, as shown in Fig. 1. Nowadays, modern wind turbines are reliable, quiet, cost-effective and commercially competitive while the wind turbine technologies are proven and mature. At present, technical challenges are generally associated with ever-growing wind turbine size, power transmission, energy storage, energy efficiency, system stability and fault tolerance.

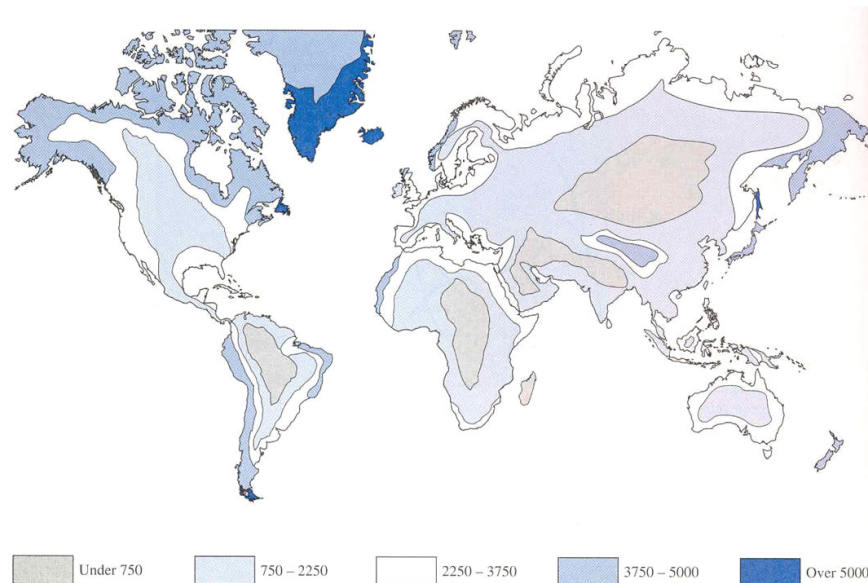

Figure 2. The world's energy potential for land-based wind turbines (estimated energy output in kWh/kW from a wind turbine that is dimensioned for 11 m/s) [36].

Currently, wind power is widely recognized as a main feasible source of renewables which can be utilized economically in large quantity. A world map for wind energy potential is illustrated in Fig. 2. Taking the United Kingdom for example, the usable offshore wind energy alone is enough to provide three times more than the required electricity consumption in the country, given sufficient support. However, wind power fluctuates by its nature and such applications demand high reliability and high availability while the market is still looking to reduce weight, complexity and operational costs.

3. Wind Turbines

Clearly, wind energy is high on the governmental and institutional agenda. However, there are some stumbling blocks in the way of its widespread.

Wind turbines come with different topologies, architectures and design features. The schematic of a wind turbine generation system is shown in Fig. 3. Some options wind turbine topologies are as follows [35],

- Rotor axis orientation: horizontal or vertical;
- Rotor position: upwind or downwind of tower;
- Rotor speed: fixed or variable;
- Hub: rigid, teetering, gimbaled or hinged blades;
- Rigidity: still or flexible;
- Number of blades: one, two, three or even more;
- Power control: stall, pitch, yaw or aerodynamic surfaces;
- Yaw control: active or free.

This chapter focuses only on horizontal-axis wind turbines (HAWTs), which are the prevailing type of wind turbine topology, as is confirmed in Fig. 4.

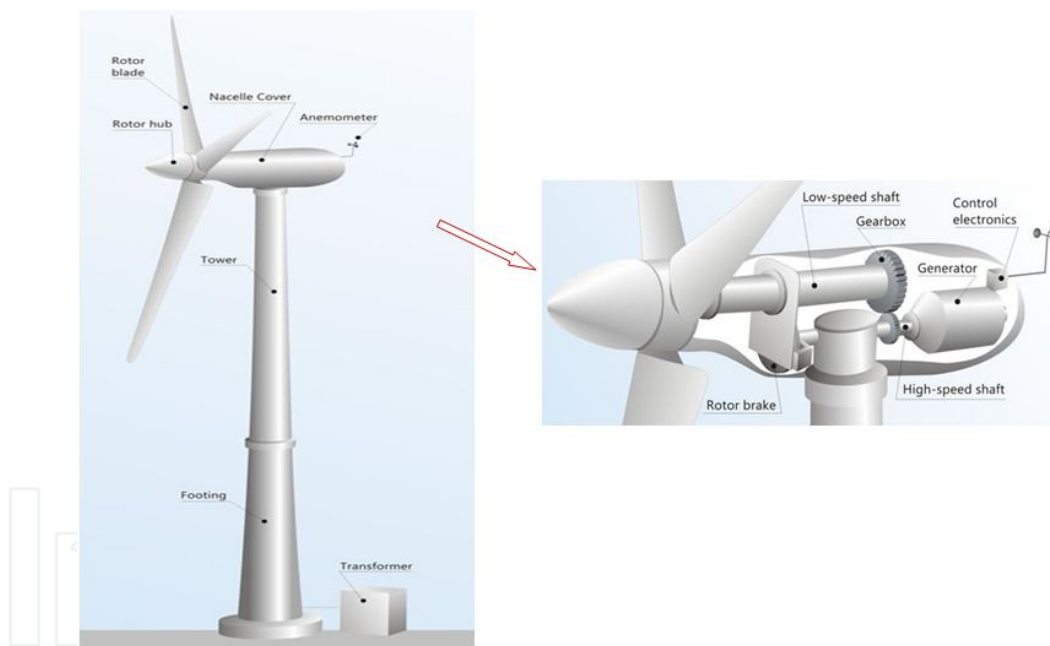

Figure 3. Schematic of a wind turbine generation system [50].

Wind turbines include critical mechanical components such as turbine blades and rotors, drive train and generators. They cost more than 30% of total capital expenditure for offshore wind project [24]. In general, wind turbines are intended for relatively inaccessible sites placing some constraints on the designs in a number of ways. For offshore environments, the site may be realistically accessed for maintenance once per year. As a result, fault tolerance of the wind turbine is of importance for wind farm development.

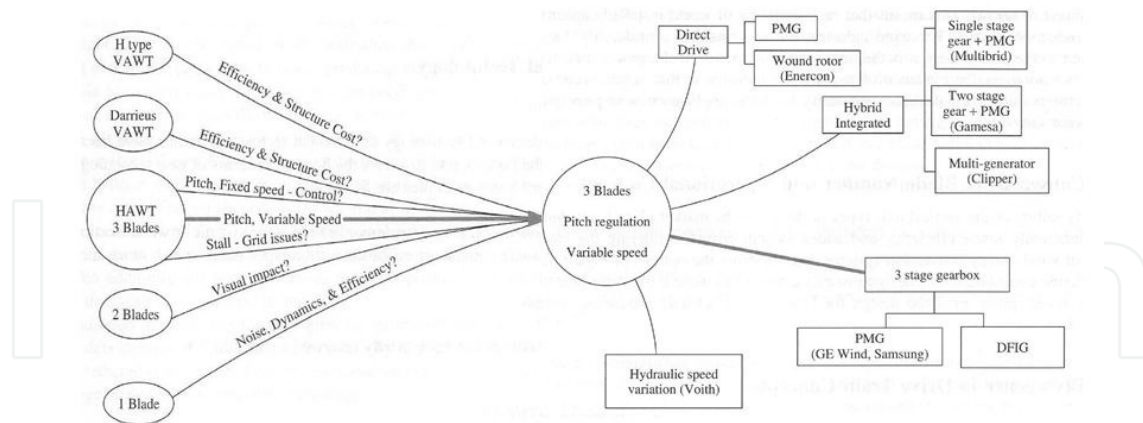

Figure 4. Commonly agreed wind turbine type and its divergence [24].

One of key components in the wind turbine is its drive train, which links aerodynamic rotor and electrical output terminals. Optimization of wind turbine generators can not be realized without considering mechanical, structural, hydraulic and magnetic performance of the drive train. An overview of the drive train technologies is illustrated in Fig. 5 for comparison. Generally, they can be broken down into four types according to their structures [24]:

- Conventional: gearbox and high speed generator with few pole pairs.
- Direct drive: any drive train without a gearbox and low speed generator with many pole pairs.
- Hybrid: any drive train with a gearbox and the generator speed between the above two types.
- Multiple generators: any drive train with more than one generator.

Drive train topologies may raise the issues such as the integration of the rotor and gearbox/bearings, the isolation of gear and generator shafts from mechanical bending loads, the integrity and load paths. Although it may be easier to service separate wind turbine components such as gearboxes, bearings and generators, the industry is increasingly in favor of system design of the integrated drive train components.

4. Wind Turbine Generators

One of limiting factors in wind turbines lies in their generator technology. There is no consensus among academics and industry on the best wind turbine generator technology. Traditionally, there are three main types of wind turbine generators (WTGs) which can be considered for the various wind turbine systems, these being direct current (DC), alternating current (AC) synchronous and AC asynchronous generators. In principle, each can be run at fixed or variable speed. Due to the fluctuating nature of wind power, it is advantageous to

operate the WTG at variable speed which reduces the physical stress on the turbine blades and drive train, and which improves system aerodynamic efficiency and torque transient behaviors.

(a) DC Generator Technologies

In conventional DC machines, the field is on the stator and the armature is on the rotor. The stator comprises a number of poles which are excited either by permanent magnets or by DC field windings. If the machine is electrically excited, it tends to follow the shunt wound DC generator concept.

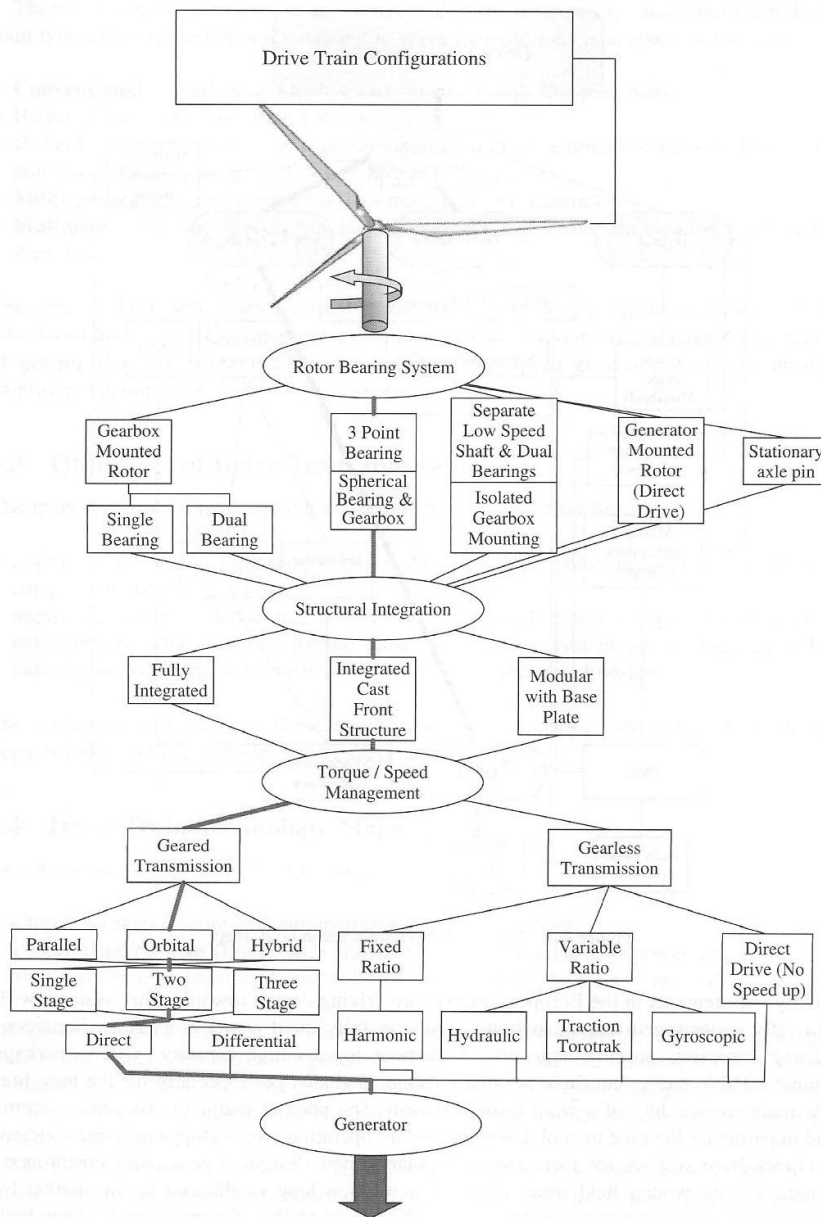

Figure 5. System level drive train technologies [24].

An example of the DC wind generator system is illustrated in Fig. 6. It consists of a wind turbine, a DC generator, an insulated gate bipolar transistor (IGBT) inverter, a controller, a transformer and a power grid. For shunt wound DC generators, the field current (and thus magnetic field) increases with operational speed whilst the actual speed of the wind turbine is determined by the balance between the WT drive torque and the load torque. The rotor includes conductors wound on an armature which are connected to a split-slip ring commutator. Electrical power is extracted through brushes connecting the commutator which is used to rectify the generated AC power into DC output. Clearly, they require regular maintenance and are relatively costly due to the use of commutators and brushes.

In general, these DC WTGs are unusual in wind turbine applications except in low power demand situations [47; 23; 33; 54] where the load is physically close to the wind turbine, in heating applications or in battery charging.

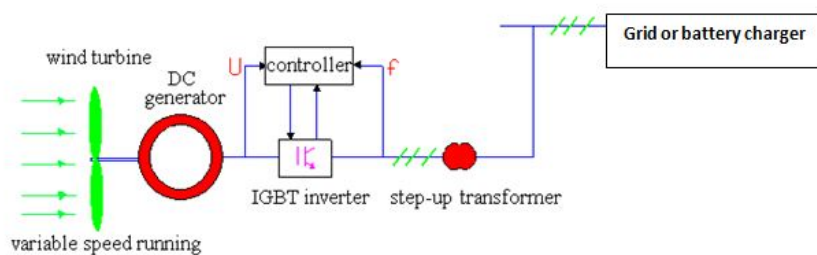

Figure 6. Schematic of a DC generator system [33].

(b) AC Synchronous Generator Technologies

Since the early time of developing wind turbines, considerable efforts have been made to utilize three-phase synchronous machines. AC synchronous WTGs can take constant or DC excitations from either permanent magnets or electromagnets and are thus termed PM synchronous generators (PMSGs) and electrically excited synchronous generators (EESGs), respectively. When the rotor is driven by the wind turbine, a three-phase power is generated in the stator windings which are connected to the grid through transformers and power converters. For fixed speed synchronous generators, the rotor speed must be kept at exactly the synchronous speed. Otherwise synchronism will be lost.

Synchronous generators are a proven machine technology since their performance for power generation has been studied and widely accepted for a long time. A cutaway diagram of a conventional synchronous generator is shown in Fig. 7. In theory, the reactive power characteristics of synchronous WTGs can be easily controlled via the field circuit for electrical excitation. Nevertheless, when using fixed speed synchronous generators, random wind speed fluctuations and periodic disturbances caused by tower-shading effects and natural resonances of components would be passed onto the power grid. Furthermore, synchronous WTGs tend to have low damping effect so that they do not allow drive train transients to be absorbed electrically. As a consequence, they require an additional damping element (e.g. flexible

coupling in the drive train), or the gearbox assembly mounted on springs and dampers. When they are integrated into the power grid, synchronizing their frequency to that of the grid calls for a delicate operation. In addition, they are generally more complex, costly and more prone to failure than induction generators. In the case of using electromagnets in synchronous machines, voltage control takes place in the synchronous machine while in permanent magnet excited machines, voltage control is achieved in the converter circuit.

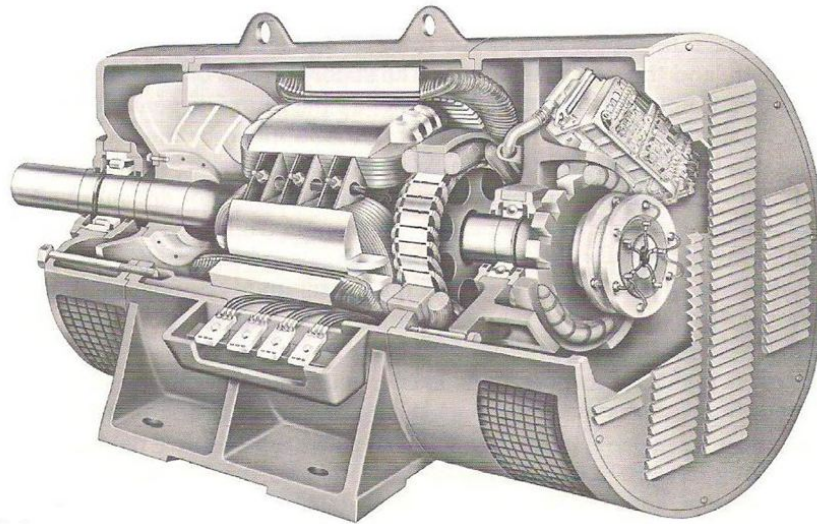

Figure 7. Cutaway of a synchronous generator [22].

In recent decades, PM generators have been gradually used in wind turbine applications due to their high power density and low mass [39]. Often these machines are referred to as the permanent magnet synchronous generators (PMSGs) and are considered as the machine of choice in small wind turbine generators. The structure of the generator is relatively straightforward. As shown in Fig. 8, the rugged PMs are installed on the rotor to produce a constant magnetic field and the generated electricity is taken from the armature (stator) via the use of the commutator, sliprings or brushes. Sometimes the PMs can be integrated into a cylindrical cast aluminum rotor to reduce costs [35]. The principle of operation of PM generators is similar to that of synchronous generators except that PM generators can be operated asynchronously. The advantages of PMSGs include the elimination of commutator, slip rings and brushes so that the machines are rugged, reliable and simple. The use of PMs removes the field winding (and its associated power losses) but makes the field control impossible and the cost of PMs can be prohibitively high for large machines.

Because the actual wind speeds are variable, the PMSGs can not generate electrical power with fixed frequency. As a result, they should be connected to the power grid through AC-DC-AC conversion by power converters. That is, the generated AC power (with variable frequency and magnitude) is first rectified into fixed DC and then converted back into AC power (with fixed frequency and magnitude). It is also very attractive to use these permanent magnet machines for direct drive application. Obviously, in this case, they can elimi-

nate troublesome gearboxes which cause the majority of wind turbine failures. The machines should have large pole numbers and are physically large than a similarly rated geared machine.

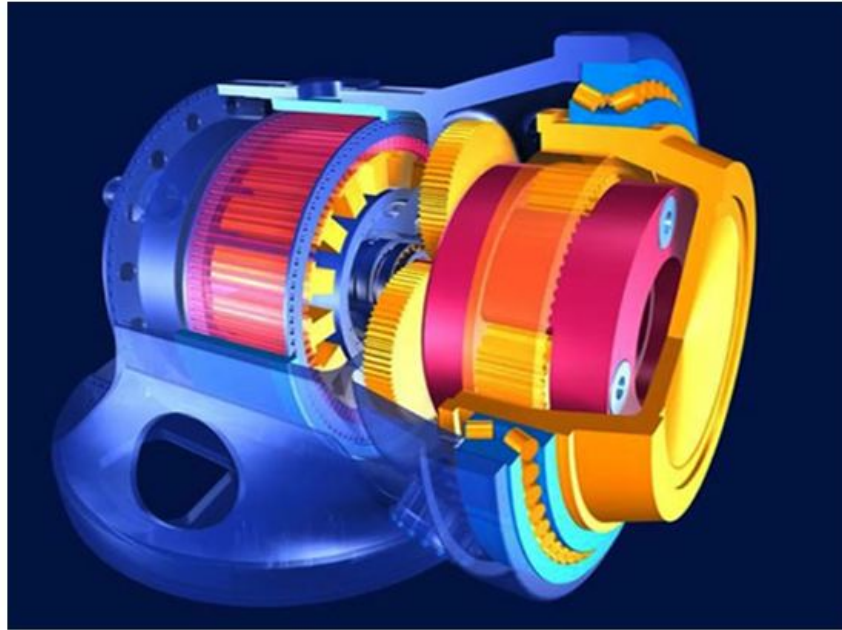

Figure 8. Cutaway of a permanent magnet synchronous generator [18].

A potential variant of synchronous generators is the high-temperature superconducting generator [31; 27; 49; 55]. See Fig. 9 for a multi-MW, low-speed HTS synchronous generator system. The machine comprises the stator back iron, stator copper winding, HTS field coils, rotor core, rotor support structure, rotor cooling system, cryostat and external refrigerator, electromagnetic shield and damper, bearing, shaft and housing. In the machine design, the arrangements of the stator, rotor, cooling and gearbox may pose particular challenges in order to keep HTS coils in the low temperature operational conditions.

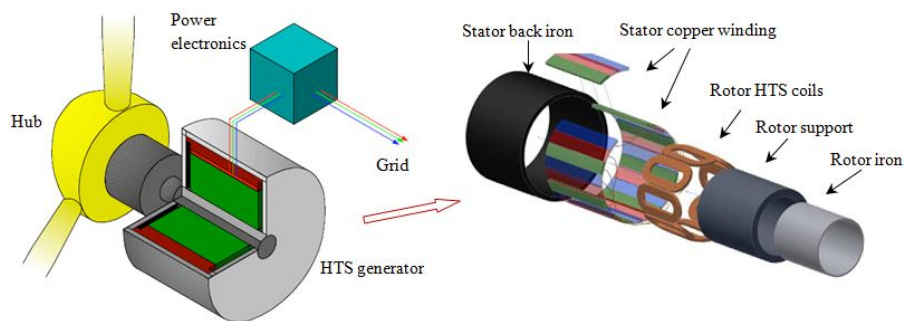

Figure 9. Schematic of a HTS synchronous generator system [11].

Superconducting coils may carry 10 times the current than conventional copper wires with negligible resistance and conductor losses. Without a doubt, the use of superconductors would eliminate all field circuit power loss and the ability of superconductivity to increase current density allows for high magnetic fields, leading to a significant reduction in mass and size for wind turbine generators. Therefore, superconducting generators provide much promise in high capacity and weight reductions, perhaps suited better for wind turbines rated 10 MW or more. In 2005, Siemens successfully launched the world's first superconducting wind turbine generator, which was a 4MW synchronous generator. However, there are many technical challenges to face especially for the long-life, low-maintenance wind turbine systems. For instance, there is always a necessity to maintain cryogenic systems so that the time to cool down and restore operation following a stoppage will be an additional issue.

(c) AC Asynchronous Generators

Whilst conventional power generation utilizes synchronous machines, modern wind power systems use induction machines extensively in wind turbine applications. These induction generators fall into two types: fixed speed induction generators (FSIGs) with squirrel cage rotors (sometimes called squirrel cage induction generators-SQIGs) [40; 1] and doubly-fed induction generators (DFIGs) with wound rotors [9; 29; 19; 32, 43; 13; 34]. Cutaway diagrams of a squirrel-cage induction generator and a doubly-fed induction generator are presented in Fig. 10 and Fig. 11, respectively, and their system topologies are further illustrated in Fig. 12.

When supplied with three-phase AC power to the stator, a rotating magnetic field is established across the airgap. If the rotor rotates at a speed different to synchronous speed, a slip is created and the rotor circuit is energized. Generally speaking, induction machines are simple, reliable, inexpensive and well developed. They have high degree of damping and are capable of absorbing rotor speed fluctuations and drive train transients (i.e. fault tolerant). However, induction machines draw reactive power from the grid and thus some form of reactive power compensation is needed such as the use of capacitors or power converters. For fixed-speed induction generators, the stator is connected to the grid via a transformer and the rotor is connected to the wind turbine through a gearbox. The rotor speed is considered to be fixed (in fact, varying within a narrow range). Up until 1998 most wind turbine manufacturers built fixed-speed induction generators of 1.5 MW and below. These generators normally operated at 1500 revolutions per minute (rpm) for the 50 Hz utility grid [37], with a three-stage gearbox.

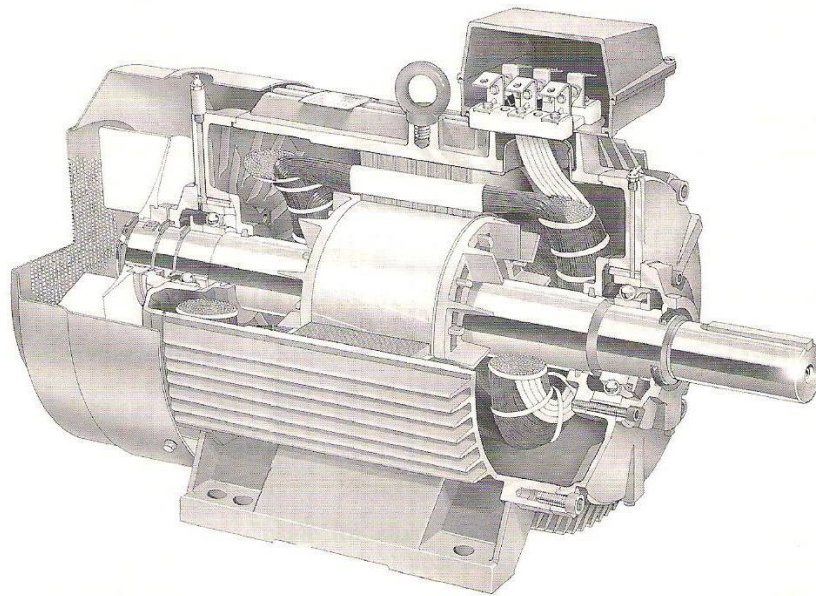

Figure 10. Cutaway of a squirrel-cage induction generator [22].

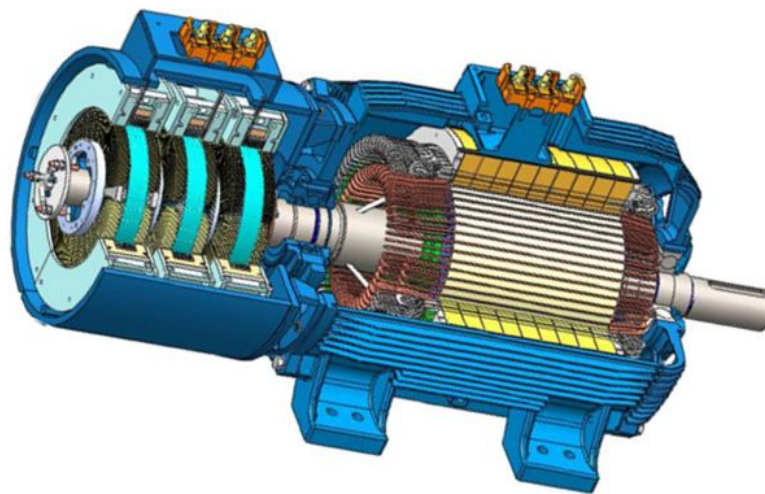

Figure 11. Cutaway of a doubly-fed induction generator with a rotary transformer [43].

SCIGs can be utilized in variable speed wind turbines, as in controlling synchronous machines. However, the output voltage can not be controlled and reactive power needs to be supplied externally. Clearly, fixed speed induction generators are limited to operate only within a very narrow range of discrete speeds. Other disadvantages of the machines are related to the machine size, noise, low efficiency and reliability. These machines have proven to cause tremendous service failures and consequent maintenance.

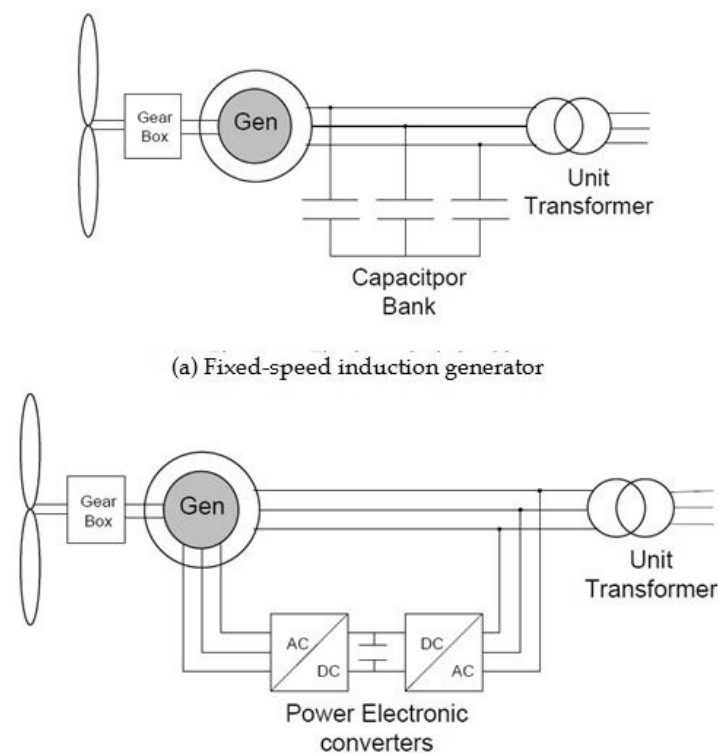

Figure 12. Schematic of two induction generator systems.

SCIGs led the wind turbine market until the last millennium [16; 26], overtaken by the wide adoption of DFIGs. Nowadays, over 85% of the installed wind turbines utilize DFIGs [41] and the largest capacity for the commercial wind turbine product with DFIG has increased towards 5MW in industry. In the DFIG topology, the stator is directly connected to the grid through transformers and the rotor is connected to the grid through PWM power converters. The converters can control the rotor circuit current, frequency and phase angle shifts. Such induction generators are capable of operating at a wide slip range (typically $\pm 30\%$ of synchronous speed). As a result, they offer many advantages such as high energy yield, reduction in mechanical stresses and power fluctuations, and controllability of reactive power.

For induction generators, all the reactive power energizing the magnetic circuits must be supplied by the grid or local capacitors. Induction generators are prone to voltage instability. When capacitors are used to compensate power factor, there is a risk of causing self-excitation. Additionally, damping effect may give rise to power losses in the rotor. There is no direct control over the terminal voltage (thus reactive power), nor sustained fault currents.

As shown in Fig. 12(b), the rotor of the DFIG is mechanically connected to the wind turbine through a drive train system, which may contain high and low speed shafts, bearings and a gearbox. The rotor is fed by the bi-directional voltage-source converters. Thereby, the speed and torque of the DFIG can be regulated by controlling the rotor side converter (RSC). Another feature is that DFIGs can operate both sub-synchronous and super-synchronous conditions. The stator always transfers power to the grid while the rotor can handle power in

both directions. The latter is due to the fact that the PWM converters are capable of supplying voltage and current at different phase angles. In sub-synchronous operation, the rotor-side converter acts as an inverter and the grid-side converter (GSC) as a rectifier. In this case, active power is flowing from the grid to the rotor. Under super-synchronous condition, the RSC operates as a rectifier and the GSC as an inverter. Consequently, active power is flowing from the stator as well as the rotor to the power grid.

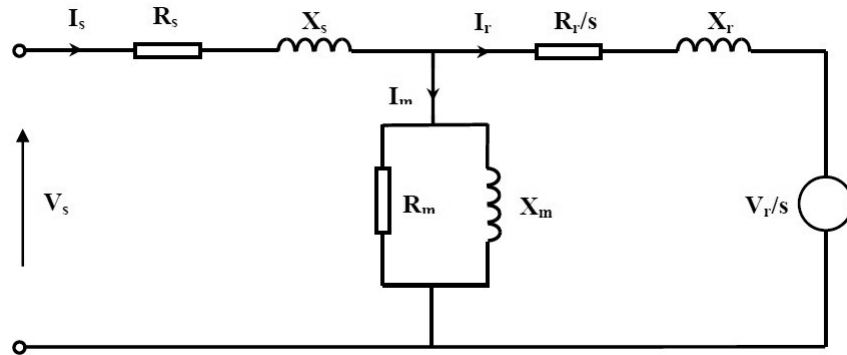

Figure 13. Per-phase equivalent circuit of the DFIG.

To analyze the DFIG's performance, it always needs to adopt its per-phase equivalent circuit, as exemplified in Fig. 13. From this figure, it can be seen that the DFIG differs from the conventional induction machine in the rotor circuit where a voltage source is added to inject voltage into the rotor circuit. The actual d - q control of the DFIG is similar to the magnitude and phase control of the injected voltage in the circuit.

The matrix form of the equation for this circuit is

$$\begin{bmatrix} V_s \\ V_r/s \end{bmatrix} = \begin{bmatrix} R_s + j(X_s + X_m) & -jX_m \\ -jX_m & R_r/s + j(X_r + X_m) \end{bmatrix} \begin{bmatrix} I_s \\ I_r \end{bmatrix} \quad (1)$$

The input power P_{in} can be summarized from the output power P_{out} and the total loss P_{loss} . The latter includes stator conductor loss P_{cu1} , rotor conductor loss P_{cu2} , core loss P_{core} , windage and friction losses P_{wf} and stray load loss P_{stray} . Among these losses, P_{cu1} is assumed to vary with the square of the stator current I_s while P_{cu2} varies with the square of the rotor current I_r . The stray load loss could be split into two parts: the fundamental component P_{fun} occurring at the stator side and P_{har} at the rotor side. Thus P_{fun} is proportional to I_s^2 while P_{har} is proportional to I_r^2 .

The total loss is then given by

$$P_{loss} = 3I_s^2(R_s + R_{fun}) + 3I_r^2(R_r' + R_{har}) + P_{core} + P_{wf} \quad (2)$$

The efficiency of the DFIG is

$$\eta = \frac{P_{out}}{P_{in}} = \frac{3V_{out} \cos \varphi_r}{6I_s(R_s + R_{fun} + R_r' + R_{har}) + 3V_{out} \cos \varphi_r} \quad (3)$$

The efficiency can be expressed as a function of the load current I_s and this function is continuous and monotonic. Consequently, the maximum efficiency can be found when

$$\frac{\partial \eta}{\partial I_s} = 0 \quad (4)$$

That is, the condition of maximum efficiency for DFIGs is

$$P_{core} + P_{wf} = P_{cu1} + P_{cu2} + P_{stray} \quad (5)$$

In order to optimize the DFIG machine design, its losses and efficiency need to derive numerically or experimentally. An additional refinement parameter is the machine's operational point. The condition of the maximum efficiency occurrence indicates: when the load-dependent losses equalise the load-invariant losses, the machine efficiency peaks. In the design and operation of DFIGs, it is beneficial to match the generator's characteristics with the site-specific wind speed by moving this maximum efficiency point close to the rated or operational load.

For control purposes, the DFIG mathematical model is based on the synchronous reference frame as follows,

$$\begin{cases} v_{sd} = r_s i_{sd} + \frac{d\psi_{sd}}{dt} - \omega_s \psi_{sq} \\ v_{sq} = r_s i_{sq} + \frac{d\psi_{sq}}{dt} + \omega_s \psi_{sd} \end{cases} \quad (6)$$

$$\begin{cases} v_{rd} = r_r i_{rd} + \frac{d\psi_{rd}}{dt} - (\omega_s - \omega_r) \psi_{rq} \\ v_{rq} = r_r i_{rq} + \frac{d\psi_{rq}}{dt} + (\omega_s - \omega_r) \psi_{rd} \end{cases} \quad (7)$$

$$\begin{cases} \psi_{sd} = (L_{ls} + L_m) i_{sd} + L_m i_{rd} \\ \psi_{sq} = (L_{ls} + L_m) i_{sq} + L_m i_{rq} \end{cases} \quad (8)$$

$$\begin{cases} \psi_{rd} = (L_{lr} + L_m)i_{rd} + L_m i_{sd} \\ \psi_{rq} = (L_{lr} + L_m)i_{rq} + L_m i_{sq} \end{cases} \quad (9)$$

where r_s and r_r are the stator and rotor resistances in Ω , L_{ls} and L_{lr} are the stator and rotor leakage inductances in H, L_m is the magnetizing inductance in H. ω_s is the synchronous electrical speed in rad/sec. ω_r is the rotor electrical speed of the DFIG and its relation with rotor mechanical speed ω_g is $\omega_r = P\omega_g$, where P is pole pairs.

The electromagnetic torque is given by

$$T_e = \frac{3}{2} PL_m (i_{sq} i_{rd} - i_{sd} i_{rq}) \quad (10)$$

In DFIGs, active power is used to evaluate the power output and reactive power is responsible for its electrical behavior in the power network. The DFIG requires some amounts of reactive power to establish its magnetic field. In case of grid-connected systems, the generator obtains the reactive power from the grid itself [48]. In case of isolated system operation, the reactive power needs to be provided by external sources such as capacitors [4] or batteries [9].

(d) Switched Reluctance Generator Technologies

Switched reluctance WTGs are characterized with salient rotors and stator. As the rotor rotates, the reluctance of the magnetic circuit linking the stator and rotor changes, and in turn, induces currents in the winding on the armature (stator). See Fig. 14 for a schematic of the switched reluctance generator system.

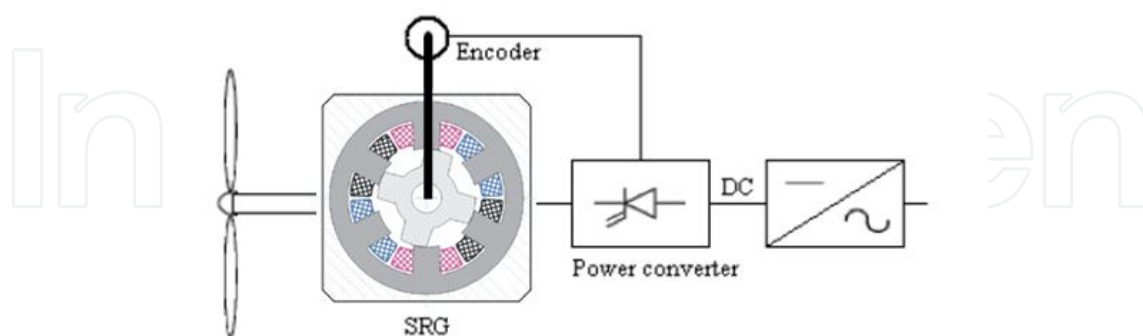

Figure 14. Schematic of a switched reluctance generator system [12].

The reluctance rotor is constructed from laminated steel sheets and has no electrical field windings or permanent magnets. As a result, the reluctance machine is simple, easy to manufacture and assembly. An obvious feature is their high reliability because they can work in

harsh or high-temperature environments. Because the reluctance torque is only a fraction of electrical torque, the rotor of switched reluctance is generally large than other with electrical excitations for a given rated torque. If reluctance machines are combined with direct drive features, the machine would be extremely large and heavy, making them less favorable in wind power applications.

5. Design Considerations and Challenges

Generally speaking, wind turbine generators can be selected from commercially available electrical machines with or without minor modifications. If a wind turbine design is required to match a specific site, some key issues should be taken into account. These include:

- Choice of machines
- Type of drive train
- Brush topology
- Rated and operating speeds
- Rated and operating torques
- Tip speed ratio
- Power and current
- Voltage regulation (synchronous generators)
- Methods of starting
- Starting current (induction generators)
- Synchronizing (synchronous generators)
- Cooling arrangement
- Power factor and reactive power compensation (induction generators)
- Power converter topology
- Weight and size
- Protection (offshore environment)
- Capital cost and maintenance.

Among these design considerations, the choice of operating speed, drive type, brush topology, and power converter are focused and further analyzed in details.

(a) Fixed or Variable Speed?

Clearly, it is beneficial to operate WTGs at variable speed. The reasons are several. When the wind speed is below rated, running the rotor speed with the wind speed and keeping the tip

speed ratio constant ensure that the wind turbine will extract the maximum energy. Variable speed operation helps reduce fluctuating mechanical stresses on the drive train and machine shaft, the likelihood of fatigue and damage as well as aerodynamically generated acoustic noise. The rotor can act as a regenerative storage unit (e.g. flywheel), smoothing out torque and power fluctuations prior to entering the drive train. Direct control of the air-gap torque also aids in minimizing gearbox torque fluctuations. Since there is a frequency converter between the wind turbine generator and the power grid, it becomes possible to decouple the network frequency and the rotor rotational speed. This permits variable speed operation of the rotor and controllability of air-gap torque of the machine. Furthermore, variable speed operation enables separate control of active and reactive power, as well as power factor. In theory, some wind turbine generators may be used to compensate the low power factor caused by neighboring consumers. In economic terms, variable speed wind turbine can produce 8-15% more power than fixed speed counterparts [45]. Nonetheless, the capital costs will be increased arising from the variable speed drive and power converters, as well as increased complicity and control requirements.

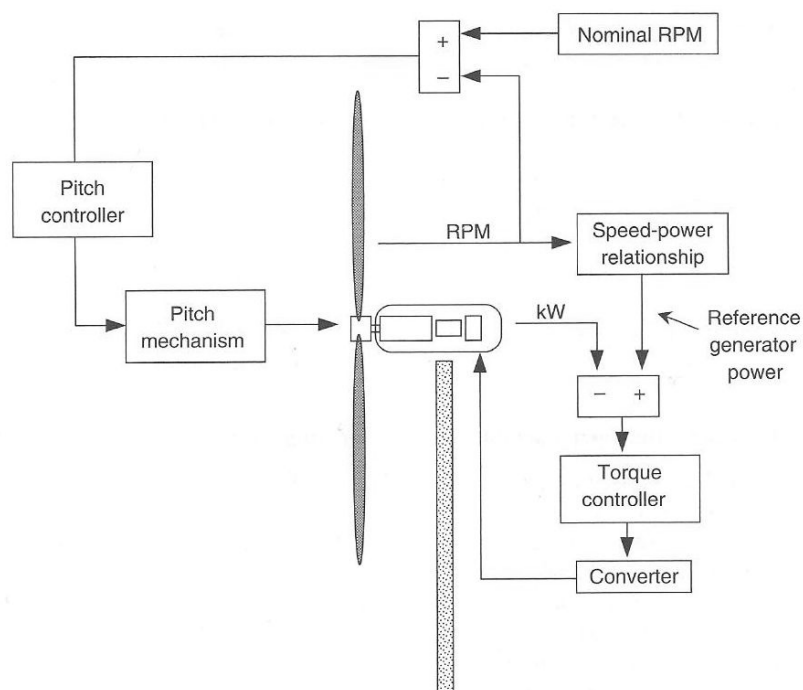

Figure 15. Variable speed control system [35].

In principle, variable speed operation can be achieved mechanically by the use of differential gearboxes or continuously-variable transmission systems [8], based on the control of speed and angular speed of gyroscopes. But the general practice is to achieve this goal by electrical means. There are two major methods in use: broad range and narrow range variable speed [8]. The former refers to a wide operational range from zero to the full rated speed where the latter refers to a narrow operational range between a fraction (up to $\pm 50\%$) of synchronous speed. In reality, this latter range is practically sufficient and can saving significant

costs on power electronic converters. A closed loop speed control of such a method is demonstrated in Fig. 15.

In the design of variable-speed wind turbines, three control aspects in association with the wind speed need to be considered. First, a constant optimized tip speed should be maintained to achieve maximum aerodynamic efficiency by varying the rotor speed with the actual wind speed. Second, the rotor speed should be maintained constant after the rotor has reached its rated speed but the power has not, in the case of moderate winds. When the wind speed is higher, the control is to maintain a constant rated power via the pitch angle control or stall control. Whilst using the pitch angle control, the blade pitch is varied to control the rotor speed together with the generator torque.

(b) Direct or Geared Drive?

In a geared wind turbine, the generator speed increases with the gear ratio so that the reduction in machine weight is offset by the gain in gearbox weight. For instance, the wind turbine operates at a speed of 15 rpm and the generator is designed to operate 1200 rpm (for 60 Hz) [2]. An up-speed gearbox of 1:80 is required to match the speed/torque of the turbine with those of the generator.

However, historically, gearbox failures are major challenges to the operation of wind farms. This is especially true for offshore wind turbines which are situated in harsh and less-accessible environments. Because of this, direct drive systems are increasingly desired in new wind turbine systems. One example is the excited synchronous generator with wound field rotor is a well-established design in the marketplace; and another may be a popular neodymium magnet generator design which also attracts much attention in the marketplace.

Obviously, direct drive configuration removes the necessity for gears and the related reliability problems [46]. Therefore, some wind turbine manufacturers are now moving toward direct-drive generators to improve system reliability. Since wind turbine generators are operated with power electronic converters, direct drive topology can provide some flexibility in the voltage and power requirements of the machines. Nonetheless, a drawback of the direct drive is associated with the low operating speed of the turbine generator. As the nominal speed of the machine reduces, the volume and weight of its rotor would increase approximately in inverse proportion for a given power output. This can be explained in the following equation governing the power output of any rotating electrical machine [28],

$$P = k \times (D^2 L) \times n \quad (11)$$

where k is a constant, n is the rotor rotational speed, D is the rotor diameter and L is the rotor length, in arbitrary units.

Direct drive increases the size of electrical generators which effectively offsets some of the weight savings from removing gearboxes. See Fig. 16 for a direct drive wind turbine generator, which is more than 10 times larger than its equivalent geared machine. Moreover, it typically requires the full rated power converters for grid connection. As a consequence, it is

always needed to strike a balance between the weight of machines and the weight of gear-boxes. Hybrid systems use one or two stages of gears rather than three or four required by conventional MW generators. Sometimes, hybrid systems can offer a better compromise in terms of the overall performance of the wind turbine system.



Figure 16. Example of a direct drive MW wind turbine generator.

For direct drive, the popular machine option is the PM synchronous machines. Although considerable effort and investment have been spent on improving reluctance machines [10; 15], they are still not commercially competitive to date. Direct drive brings about some design challenges on the generator and the power converters. For PM direct drive generators, they require a significant amount of costly rare-earth permanent magnets [51; 53; 44]. In addition, it needs to increase the rating of IGBTs in the back-to-back converter, or to integrate machine side converter components with the stator windings. Obviously, the advantage of

direct drive is the removal of gearbox at the expense of increased size and weight of the wind turbine generator. As a rule of thumb, the machine volume is proportional to the torque required and inversely proportional to the operational speed for a given power. The increased mass of the generator can be a limiting factor for offshore installations because the shipping carrying capacity is generally limited to 100 tons so that the direct drive generator may not be greater than 10 MW.

With the hybrid option, the generator size and speed lie in between direct and geared drives. In this case, synchronous machines are more popular than induction machines. It generally involves medium-speed, multi-pole generators which are almost exclusively permanent magnet machines. The hybrid drive train can facilitate more nacelle arrangements and match the size of the generator and gearbox.

(c) Brushed or Brushless Topology?

In general, DC machines, wound rotor synchronous generators, wound rotor induction generators all employ commutators, brushes or sliprings to access the rotating rotor circuits. Consequently, routine maintenance and replacement lead to some difficulties in wind power applications, especially for offshore installations. Clearly it would be particularly desirable to rid of any components physically connected to the rotating parts of wind turbines. There are several ways of achieving this. Taking the DFIG for example, brushless doubly-fed generators (BDFGs) can be a solution. They use two windings on the stator (a power winding and a control winding) with different pole numbers. The rotor can be of squirrel cage type and an indirect coupling of the two stator windings is established through the rotor. It is also possible to use a reluctance rotor in this topology where the machine has become a brushless reluctance generator [6, 14, 25]. By modifying the conventional machines, a higher reliability is achieved due to the absence of the brushes and slip rings. The penalty is the use of two machines in a machine case.

(d) Two-Level, Multi-Level or Matrix Converter?

Power electronics is recognized as being a key and enabling component in wind turbine systems. Broadly, there are three types of converters widely used in the wind market. These are two-level, multi-level and matrix converters.

Two level power converters are commonly called “back-to-back PWM converters”, as shown in Fig. 17(a). They include two voltage source inverters (with PWM control scheme) connected through a DC capacitor. This is a mature technology but suffers from high costs, high switching loss and large DC capacitors. Any power converters having three or more voltage levels are termed “multi-level converters”. These are illustrated in Fig. 17(b). They are particularly favored in multi-MW wind turbines since they offer better voltage and power capacity, lower switching loss and total harmonic distortion. However, the power electronic circuits are more complex and costly.

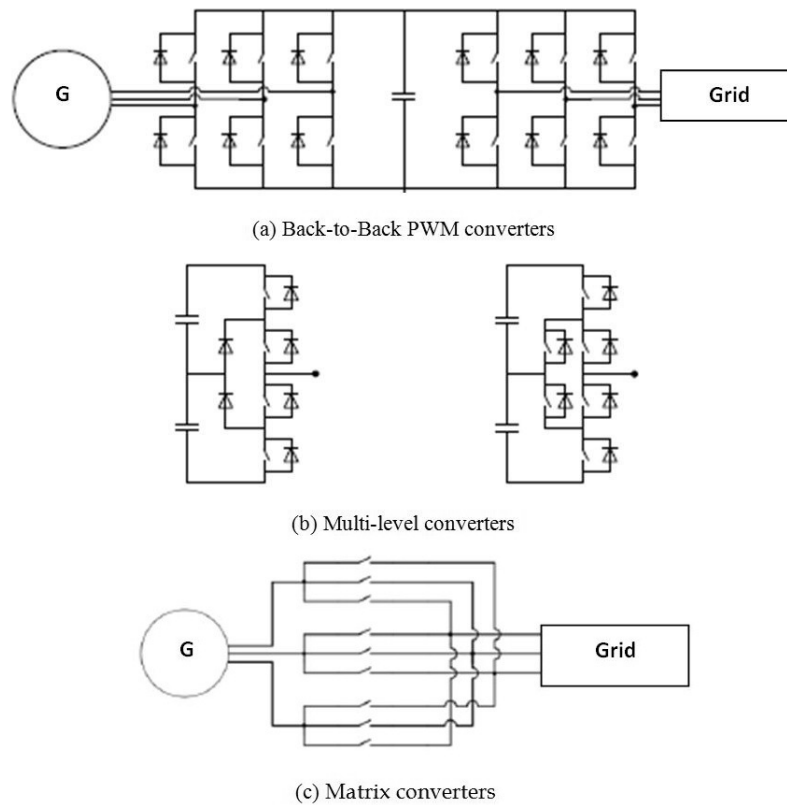

Figure 17. Three types of power converters in wind applications. (a) [21], (b) [42], (c)[5].

On the contrary, matrix converters are different in the way of AC-AC conversion. They remove the necessity of a DC stage and directly synthesize the incoming AC voltage waveform to match the required AC output. As shown in Fig. 17(c), they generally have nine power electronic switches with three in a common leg. The elimination of DC capacitors improves the reliability, size, efficiency and cost of power converters. The downsides are the limited voltage (up to 86% of the input voltage), sensitivity to grid disturbances [26], and high conducting power loss.

5. Performance Comparisons

A quantitative comparison of DFIGs, synchronous and PM generators is listed in Table 1. It can be seen that direct drive wind turbine generators are larger in size but shorter in length compared to geared counterparts. From this limited range of data, three-stage geared DFIGs appear to be lightest; conventional synchronous generators are the heaviest and the mostly costly machines.

In addition, a performance comparison of different wind turbine generators is summarized in Table 2.

Parameter	DFIG		Synchronous generators		
	1-stage geared	3-stage geared	Electro-excited direct drive	PM 1-stage geared	PM direct drive
Air-gap diameter (m)	3.6	0.84	5	3.6	5
Stack length (m)	0.6	0.75	1.2	0.4	1.2
Iron weight (ton)	8.65	4.03	32.5	4.37	18.1
Copper weight (ton)	2.72	1.21	12.6	1.33	4.3
PM weight (ton)				0.41	1.7
Generator active material cost (kEuro)	67	30	287	43	162
Gearbox cost (kEuro)	120	220		120	
Converter cost (kEuro)	40	40	120	120	120
Generator construction cost (kEuro)	60	30	160	50	150
Total generator system cost (kEuro)	287	320	567	333	432
Annual electricity yield (MWh)	7760	7690	7740	7700	7890
Yield/total cost (kWh/Euro)	4.22	4.11	3.67	4.09	3.98

Table 1. Quantitative comparison of three major wind turbine generators [38; 30].

Performance indicator	DC generators	Induction generators		Synchronous generators			
		FSIG	DFIG	Electromagnet	PM	Reluctance	HTS
Speed	variable	fixed	variable	variable	variable	variable	variable
Power supply	directly to the grid	directly to the grid	partially stator-converter	totally via converters	totally via converters	totally via converters	totally via converters
Voltage fluctuation	high	high	low	low	low	medium	very low
Converter scale	100%	0%	app. 30%	100%	100%	100%	100%
Controllability	poor	poor	good	good	good	good	very good
Active-reactive power control	no	dependent	separate	separate	separate	separate	separate
Grid-support capability	low	low	high	medium	very high	medium	high
Efficiency	low	low	high	high	very high	medium	extremely high
Reliability	poor	medium	high	high	high	very high	high

Performance indicator	DC generators	Induction generators		Synchronous generators			
		FSIG	DFIG	Electromagnet	PM	Reluctance	HTS
Fault response	slow	slow	high	high	high	high	very high
Cost	low	low	medium	medium	high	medium	very high
Mass saving	low	low	high	medium	very high	low	extremely high
Suitability	low power, small residential application	small wind turbines	medium-large wind turbines	small-medium wind turbines	direct drive; small-medium wind turbines	early stage	large wind turbines; early stage

Table 2. Overall performance comparison of different wind turbine generators (partially, 3; 20).

6. Conclusions

Wind energy has attracted much attention from research and industrial communities. One of growth areas is thought to be in the offshore wind turbine market. The ongoing effort to develop advanced wind turbine generator technologies has already led to increased production, reliability, maintainability and cost-effectiveness. At this stage, the doubly-fed induction generator technology (equipped with fault-ride-through capacity) will continue to be prevalent in medium and large wind turbines while permanent magnet generators may be competitive in small wind turbines. Other types of wind turbine generators have started to penetrate into the wind markets to a differing degree. The analysis suggests a trend moving from fixed-speed, geared and brushed generators towards variable-speed, gearless and brushless generator technologies while still reducing system weight, cost and failure rates.

This paper has provided an overview of different wind turbine generators including DC, synchronous and asynchronous wind turbine generators with a comparison of their relative merits and disadvantages. More in-depth analysis should be carried out in the design, control and operation of the wind turbines primarily using numerical, analytical and experimental methods if wind turbine generators are to be further improved. Despite continued research and development effort, however, there are still numerous technological, environmental and economic challenges in the wind power systems.

In summary, there may not exist the best wind turbine generator technology to tick all the boxes. The choice of complex wind turbine systems is largely dictated by the capital and operational costs because the wind market is fundamentally cost-sensitive. In essence, the decision is always down to a comparison of the material costs between rare-earth permanent magnets, superconductors, copper, steel or other active materials, which may vary remarkably from time to time.

Acknowledgements

The authors gratefully acknowledge the helpful discussions with Prof G. Asher of Nottingham University and Prof B. Mecrow of Newcastle University, UK.

Author details

Wenping Cao¹, Ying Xie^{2*} and Zheng Tan¹

*Address all correspondence to: ying.xie@hust.edu.cn

1 University of Newcastle upon Tyne, United Kingdom

2 Harbin University of Science and Technology, P. R. China

References

- [1] Abo-Khalil, A. G. (2011). A new wind turbine simulator using a squirrel-cage motor for wind power generation systems. *IEEE Ninth International Conference on Power Electronics and Drive Systems (PEDS)*, 750-755.
- [2] Al-Majed, S. I., & Fujigaki, T. (2010). Wind power generation: An overview. *the International Symposium on Modern Electric Power Systems (MEPS)*, 1-6.
- [3] Aly, H. H., & El -Hawary, M. E. (2010). An overview of offshore wind electric energy resources. *23rd Canadian Conference on Electrical and Computer Engineering CCECE*, 1-8.
- [4] Bansal, R. C., Zobaa, A. F., & Saket, R. K. (2005). Some issues related to power generation using wind energy conversion systems: an overview. *Int. J. Emerging Electr. Power Syst.*, 3(2), Article 1070.
- [5] Barakati, M., Kazerani, M., & Aplevich, D. (2009). Maximum power tracking control for a wind turbine system including a matrix converter". *IEEE Power & Energy Society General Meeting (PES)*, 1.
- [6] Betz, R. E., & Jovanovic, M. G. (2000). The brushless doubly fed reluctance machine and the synchronous reluctance machine-a comparison. *IEEE Transactions on Industry Applications*, 36(4), 1103-1110.
- [7] BTM Consult ApS. (2010). World market update 2010 forecast 2010-2014. 978-8-79918-698-3.
- [8] Burton, T., Sharpe, D., Jenkins, N., & Bossanyi, E. (2001). Wind energy handbook. Wiley & Sons,, England.

- [9] Caratozzolo, P., Fossas, E., Pedra, J., & Riera, J. (2000). Dynamic modeling of an isolated system with DFIG. *Eighth IEEE Int. Powe Electronics Congress Conf.*, 287-292.
- [10] Cardenas, R., Pena, R., Perez, M., Clare, J., Asher, G., & Wheeler, P. (2005). Control of a switched reluctance generator for variable-speed wind energy applications. *IEEE Transactions on Energy Conversion*, 20(4), 781-791.
- [11] Converteam, (2012). High Temperature Superconducting (HTS)- Converteam. online: http://www.converteam.com/converteam/1/doc/Markets/Energy_Wind/HTS_Data-sheet.GB.7018.gb.10.07.01.pdf
- [12] Darie, E., & Cepisca, C. (2008). The use of switched reluctance generator in wind energy applications. *13th Power Electronics and Motion Control Conference (EPE-PEMC)*, 1963-1966.
- [13] Delli, Colli. V., Marignetti, F., & Attaianese, C. (2012). Analytical and multiphysics approach to the optimal design of a 10-MW DFIG for direct-drive wind turbines. *IEEE Transactions on Industrial Electronics*, 59(7), 2791-2799.
- [14] Dorrell, D. G., Knight, A. M., & Betz, R. E. (2011). Improvements in brushless doubly fed reluctance generators using high-flux-density steels and selection of the correct pole numbers. *IEEE Transactions on Magnetics*, 47(10), 4092-4095.
- [15] Echenique, E., Dixon, J., Cardenas, R., & Pena, R. (2009). Sensorless control for a switched reluctance wind generator, based on current slopes and neural networks. *IEEE Transactions on Industrial Electronics*, 56(3), 817-825.
- [16] Gao, G., & Chen, W. (2009, May-June). Design challenges of wind turbine generators. Montreal, Canada. *IEEE Electrical Insulation Conference (EIC)*, 146-152.
- [17] Gipe, P. (1995). Wind energy comes of age. Wiley & Sons, USA.
- [18] Google image. (2012). Magnetic generators. online:, http://www.google.co.uk/imgres?imgurl=http://magneticgeneratordiy.com/wp-content/uploads/2012/02/permanent-magnet-generator.jpg&imgrefurl=http://magneticgeneratordiy.com/permanent-magnet-generator/&h=426&w=500&sz=52&tbnid=px5NXzuFFZ_FWM:&tbnh=111&tbnw=130&prev=/search%3Fq%3Dpermanent%2Bmagnet%2Bwind%2Bturbine%2Bpicture%26tbm%3Disch%26tbo%3Du&zoom=1&q=permanent+magnet+wind+turbine+picture&usg=__SExjmg6ut-F14p2DVEB6Rkyz70Q=&hl=en&sa=X&ei=En-noT4_xEOOi0QWPmdSjCQ&ved=0CBYQ9QEwAg.
- [19] Guo, J., Yu, X., Wu, T., Chang, X., Li, S., Liu, H., & Sun, Y. (2010). Simulation and experimental analysis of grid-connected doubly-fed induction generators. *International Conference on Electrical and Control Engineering (ICECE)*, 5583-5586.
- [20] Hansen, L. H., Helle, L., Blaabjerg, F., Ritchie, E., Munk-Nielsen, S., Bindner, H., Sørensen, P., & Bak-Jensen, B. (2001). Conceptual survey of generators and power electronics for wind turbines. online: <http://www.risoe.dk/rispubl/vea/veapdf/ris-r-1205.pdf>

- [21] Hansen, L.H, Madsen, P.H, Blaabjerg, F, Christensen, H.C, Lindhard, U, & Eskildsen, K. (2001). Generators and power electronics technology for wind turbines. *The 27th Annual Conference of the IEEE Industrial Electronics Society*, 3, 2000-2005.
- [22] Heier, S. (1996). Wind energy conversion systems. Wiley & Sons, England
- [23] Hunter, R., & Elliot, G. (1994). Wind-diesel systems: a guide to the technology and its implementation. Cambridge University Press, Cambridge
- [24] Jamieson, P. (2011). Innovation in wind turbine design. Wiley, England
- [25] Jovanovic, M. (2009). Sensored and sensorless speed control methods for brushless doubly fed reluctance motors. *IET Electric Power Applications*, 3(6), 503-513.
- [26] Kim, H. S., & Lu, D. D. C. (2010). Review on wind turbine generators and power electronic converters with the grid-connection issues. *20th Australasian Universities Power Engineering Conference (AUPEC)*, 1-6.
- [27] Kim, N., Kim, G. H., Kim, K. M., Park, M., Yu, I. K., Lee, S., Song, E., & Kim, T. W. (2012). Comparative analysis of 10 MW class geared and gearless type superconducting synchronous generators for a wind power generation system. *IEEE Transactions on Applied Superconductivity*, 22(3), 5202004.
- [28] Laithwaite, E. R., & Freris, L. L. (1980). Electrical power: its generation, transmission and use. McGraw-Hill,, Maidenhead, UK.
- [29] Li, H., & Chen, Z. (2008, October). Design optimization and evaluation of different wind generator systems. Wuhan, China. *International Conference on Electrical Machines and Systems (ICEMS)*, 2396-2401.
- [30] Li, H., & Chen, Z. (2008). Overview of different wind generator systems and their comparisons. *IET Renewable Power Generation*, 2(2), 123-138.
- [31] Li, X., Zhou, y., Han, l., Zhang, D., Zhang, J., Qiu, Q., Dai, S., Zhang, Z., Xia, D., Zhang, g., Lin, L., Xiao, l., Zhu, S., Bai, H., Bian, B., Li, S., & Gao, W. (2011). Design of a high temperature superconducting generator for wind power applications. *IEEE Transactions on Applied Superconductivity Part: 2*, 21(3), 1155-11580.
- [32] Liserre, M., Cardenas, R., Molinas, M., & Rodriguez, J. (2011). Overview of multi-MW wind turbines and wind parks. *IEEE Transactions Industrial Electronics*, 58(4), 1081-1095.
- [33] Ma, H, Chen, L, Ju, P, Liu, H, Jiang, N, & Wang, C. (2009, April). Feasibility research on DC generator based wind power generation system. *International Conference on Sustainable Power Generation and Supply (SUPERGEN)*, 1-5.
- [34] Madawala, U. K., Geyer, T., Bradshaw, J. B., & Vilathgamuwa, D. M. (2012). Modeling and analysis of a novel variable-speed cage induction generator. *IEEE Transactions on Industrial Electronics*, 59(2), 1020-1028.

- [35] Manwell, J. F., Mc Gowan, J. G., & Rogers, A. L. (2009). Wind energy explained: theory, design and application. 2nd edition, Wiley, England.
- [36] NTNU, (2012). Renewable energy. Materials, online <http://www.ntnu.no>
- [37] Polinder, H. (2011). Overview and trends in wind turbine generator systems",. *IEEE Power and Energy Society General Meeting*, 1-8.
- [38] Polinder, H., van der Pijl, F. F. A., de Vilder, G. J., & Tavner, P. J. (2006). Comparison of direct-drive and geared generator concepts for wind turbines. *IEEE Transactions on Energy Conversion*, 21(3), 725-733.
- [39] Potgieter, J. H. J., & Kamper, M. J. (2012). Design of new concept direct grid-connected slip-synchronous permanent-magnet wind generator. *IEEE Transactions on Industry Applications*, 48(3), 913-922.
- [40] Quinonez-Varela, G., & Cruden, A. (2008). Modelling and validation of a squirrel cage induction generator wind turbine during connection to the local grid. *IET Generation, Transmission & Distribution*, 2(2), 301-309.
- [41] Rechesteiner, R. (2008). Wind power in context- A clean revolution in the energy sector. online, http://www.energywatchgroup.org/fileadmin/global/pdf/2009-01_Wind_Power_Report.pdf.
- [42] Rodriguez, J, Bernet, S, Steimer, P.K, & Lizama, I.E. (2010). A survey on neutral-point-clamped inverters. *IEEE Transactions on Industrial Electronics*, 57(7), 2219-2230.
- [43] Ruviaro, M., Runcos, F., Sadowski, N., & Borges, I. M. (2012). Analysis and test results of a brushless doubly fed induction machine with rotary transformer. *IEEE Transactions on Industrial Electronics*, 59(6), 2670-2677.
- [44] Semken, R. S., Polikarpova, M., Roytta, P., Alexandrova, J., Pyrhonen, J., Nerg, J., Mikkola, A., & Backman, J. (2012). Direct-drive permanent magnet generators for high-power wind turbines: benefits and limiting factors. *IET Renewable Power Generation*, 6(1), 1-8.
- [45] Shanker, T., & Singh, R. K. (2012). Wind energy conversion system: A review. *Students Conference on Engineering and Systems (SCES)*, 1-6.
- [46] Shrestha, G., Polinder, H., Bang, D., & Ferreira, J. A. (2010). Structural flexibility: A solution for weight reduction of large direct-drive wind-turbine generators. *IEEE Transactions on Energy Conversion*, 25(3), 732-740.
- [47] Suzuki, T., Okitsu, H., & Kawahito, T. (1982). Characteristics of a small wind-power system with dc generator. *IEE Proceedings Electric Power Applications B*, 129(4), 217-220.
- [48] Tazil, M., Kumar, V., Bansal, R. C., Kong, S., Dong, Z. Y., Freitas, W., & Mathur, H. D. (2010). Three-phase doubly fed induction generators: an overview. *IET Electric Power Applications*, 4(2), 75-89.

- [49] Terao, Y., Sekino, M., & Ohsaki, H. (2012). Electromagnetic design of 10 MW class fully superconducting wind turbine generators. *IEEE Transactions on Applied Superconductivity*, 22(3), 5201904.
- [50] Wavege,. (2012). Wind turbine diagram. online:, http://www.google.co.uk/imgres?imgurl=http://www.wavege.com/assets/wind-turbine-diagram-nacelle.jpg&imgrefurl=http://www.wavege.com/wind-turbine-diagram.html&h=266&w=550&sz=22&tbnid=pCbFxrGh1NQ9M:&tbnh=64&tbnw=133&prev=/search%3Fq%3Dinside%2Ba%2Bwind%2Bturbine%2Bdiagram%26tbm%3Disch%26tbo%3Du&zoom=1&q=inside+a+wind+turbine+diagram&usg=__C8M6im4YQyvtKK1zA-LYF__YLYVs=&hl=en&sa=X&ei=h8jIT8KcCYXc8gOp1sWjCg&ved=0CBoQ9QEwBA.
- [51] Westlake, A. J. G., Bumby, J. R., & Spooner, E. (1996). Damping the power-angle oscillations of a permanent-magnet synchronous generator with particular reference to wind turbine applications. *IEE Proceedings Electric Power Applications*, 143(3), 269-280.
- [52] Woodcroft, B. (1851). Translation from the Greek "Pneumatics". Taylor Walton & Maberly, London
- [53] Ying, F., Chau, K. T., & Ming, C. (2006). A new three-phase doubly salient permanent magnet machine for wind power generation. *IEEE Transactions on Industry Applications*, 42(1), 53-60.
- [54] Zhang, M., Wang, W., Chen, Y. R., & Coombs, T. (2012). Design methodology of HTS bulk machine for direct-driven wind generation. *IEEE Transactions on Applied Superconductivity*, 22(3), 5201804.
- [55] Zhang, Z., Yan, Y., & Tao, Y. (2012). A new topology of low speed doubly salient brushless DC generator for wind power generation. *IEEE Transactions on Magnetics*, 48(3), 1227-1233.

IntechOpen