

We are IntechOpen, the world's leading publisher of Open Access books Built by scientists, for scientists

4,800

Open access books available

122,000

International authors and editors

135M

Downloads

Our authors are among the

154

Countries delivered to

TOP 1%

most cited scientists

12.2%

Contributors from top 500 universities

**WEB OF SCIENCE™**Selection of our books indexed in the Book Citation Index
in Web of Science™ Core Collection (BKCI)

Interested in publishing with us?
Contact book.department@intechopen.com

Numbers displayed above are based on latest data collected.

For more information visit www.intechopen.com

Rheology – Theory and Application to Biomaterials

Hiroshi Murata

Additional information is available at the end of the chapter

<http://dx.doi.org/10.5772/48393>

1. Introduction

Rheology is science which treats the deformation and flow of materials. The science of rheology is applied to the physics, chemistry, engineering, medicine, dentistry, pharmacy, biology and so on. Classical theory of elasticity treats the elastic solid which is accordant to Hooke's law [1]. The stress is directly proportional to strain in deformations and is not dependent of the rate of strain. On the other hand, that of hydrodynamics treats the viscous liquid which is accordant to Newton's law [1]. The stress is directly proportional to rate of strain and is not dependent of the strain. However, most of materials have both of elasticity and viscosity, that is, viscoelastic properties. Mainly viscoelastic properties of the polymers are analyzed in rheology. Rheology would have two purposes scientifically. One is to determine relationship among deformation, stress and time, and the other is to determine structure of molecule and relationship between viscoelastic properties and structure of the materials.

2. Theory of rheology in polymeric materials

A strong dependence on time and temperature of the properties of polymers exists compared with those of other materials such as metals and ceramics. This strong dependence is due to the viscoelastic nature of polymers. Generally, polymers behave in a more elastic fashion in response to a rapidly applied force and in a more viscous fashion in response to a slowly applied force. Viscoelasticity means behavior similar to both purely elastic solids in which the deformation is proportional to the applied force and to viscous liquids in which the rate of deformation is proportional to the applied force. The behavior of polymers is very complex due to this dual nature.

Generally a mechanical model is used to explain viscoelastic behavior of materials which consist of springs and dashpots. The spring complies with Hooke's law as a mechanical

model with an elastic element. When a spring is fixed at one end and a load is applied at the other, it becomes instantaneously extended. Then, after the load is removed, it immediately recovers its original length [2] (Fig 1). On the other hand, the dashpot complies with Newton's law of viscosity as a mechanical model with a viscous element. When a load is applied to a dashpot, it opens gradually, strain being a function of time. Then, after the load is removed, the dashpot remains open and recovery does not occurs [2] (Fig 2). The mechanical model which consists of a Hookean spring and a Newtonian dashpot in parallel is a Voigt element (Fig 3), and that in series is a Maxwell element (Fig 4) [3]. These are simple models and the behavior of polymers can be explained by combining these models.

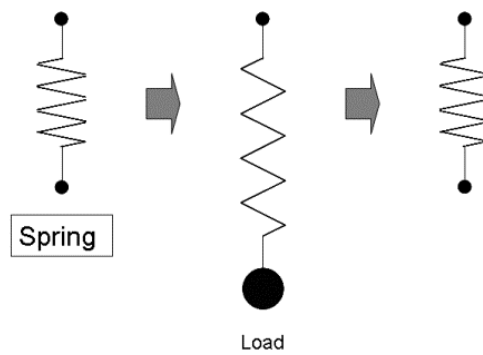

Figure 1. A spring which represents an elastic material.

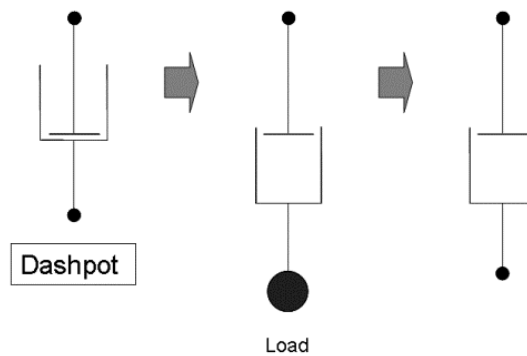

Figure 2. A dashpot which represents a viscous material.

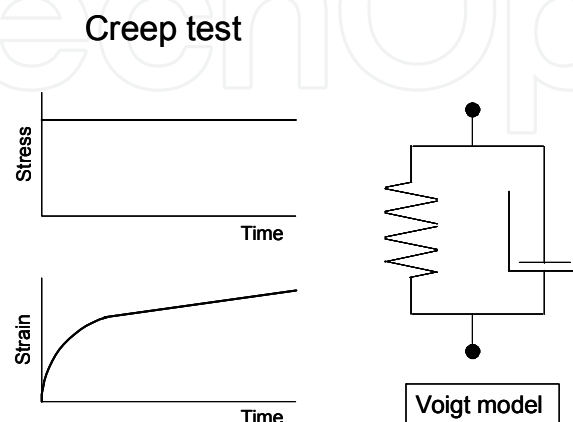

Figure 3. Creep test and a Voigt model.

Stress-relaxation test

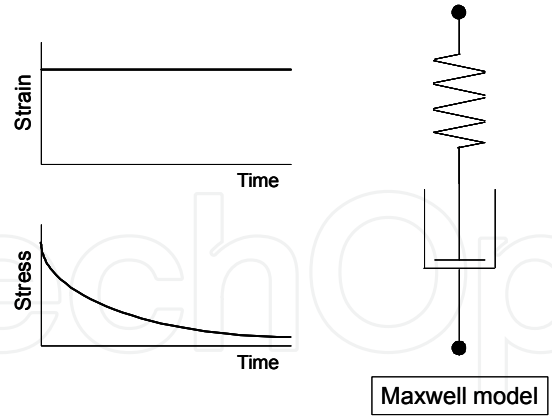

Figure 4. Stress relaxation test and a Maxwell model.

Measurement of viscoelastic properties of polymeric materials is achieved by several tests. These include static measurements such as creep test and stress relaxation test and dynamic measurement.

2.1. Creep

Creep test measures strains caused by a specific load, i.e. a definite force, in a certain range of time. This phenomenon is analyzed using a Voigt model (Fig 3).

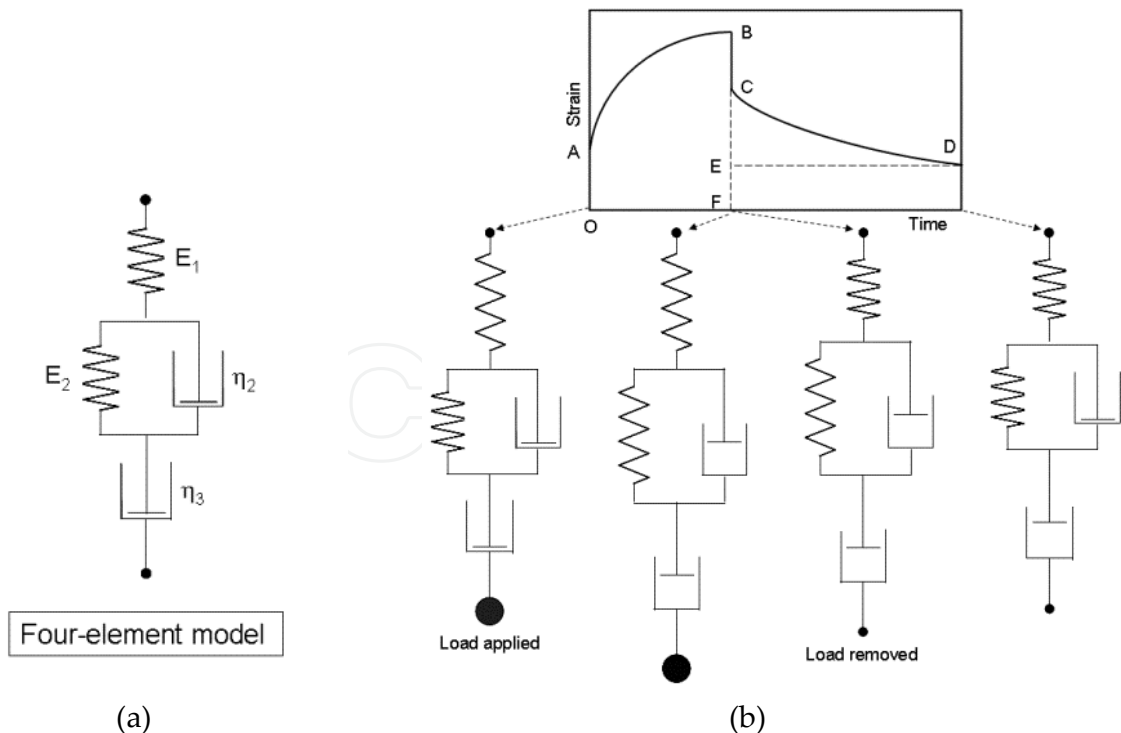

Figure 5. (a) Four-element model for creep and creep recovery; (b) creep and creep recovery. OA: Instantaneous strain; AB: Time dependent opening; BC: Instantaneous recovery (=OA); CD: Slow recovery; EF: Permanent deformation.

Furthermore, creep and creep recovery of a material can be analyzed by a four-element model (Fig 5). When a constant stress is applied at $t = 0$, the material shows an instantaneous increase in strain (the spring E_1), followed by a gradual increase in strain (the spring E_2 / dashpot η_2 and dashpot η_3). On removal of the stress, the spring E_1 recovers instantaneously followed by gradual recovery of the spring E_2 / dashpot η_2 . Some permanent deformation remains as a consequence of the dashpot η_3 [2].

2.2. Stress relaxation

Stress relaxation test measures the stress required to maintain the level of strain as a function of time after rapidly deforming a specific volume of the material. The Stress relaxation behavior of cross-linked amorphous polymer is different from that of uncross-linked amorphous polymer.

The cross-linked amorphous polymer does not flow. Thus stress relaxation curves of the cross-linked polymers are evaluated by the analogies of a three-element model in which one Maxwell element and one spring are connected in parallel (Fig 6) [4]. The equilibrium modulus to be E_e , then the relaxation modulus $E_r(t)$ for the three-element model is defined as:

$$\begin{aligned} E_r(t) &= \sigma(t) / \gamma_0 \\ &= \frac{\sigma_1(0)\exp(-t / \tau_1) + \sigma_e}{\gamma_0} \\ &= E_1(0)\exp(-t / \tau_1) + E_e \end{aligned}$$

where total stress is $\sigma(t)$, strain is γ_0 , stress on Maxwell element and degenerated element only with the spring are σ_1 and σ_e , elastic modulus E_1 , coefficient of viscosity η_1 , and relaxation time τ_1 .

The instantaneous moduli $E_0 (= E_r(0))$ and η_1 , respectively, were represented by:

$$\begin{aligned} E_0 &= E_1 + E_e = E_r(0) \\ \eta_1 &= E_1 \tau_1 \end{aligned}$$

On the other hand, uncross-linked amorphous polymer flows. Thus stress relaxation curves of the uncross-linked polymers are evaluated by the analogies of a four-element model in which two Maxwell elements are connected in parallel (Fig 7) [5]. $E_r(t)$ for the four-element model is defined as:

$$\begin{aligned} E_r(t) &= \sigma(t) / \gamma_0 \\ &= \frac{\sigma_1(0)\exp(-t / \tau_1) + \sigma_2(0)\exp(-t / \tau_2)}{\gamma_0} \\ &= E_1(0)\exp(-t / \tau_1) + E_2(0)\exp(-t / \tau_2) \end{aligned}$$

where the stress on Maxwell elements is σ_1 and σ_2 , elastic moduli are E_1 and E_2 , the coefficient of viscosity η_1 and η_2 , and the relaxation time τ_1 and τ_2 ($\tau_1 > \tau_2$).

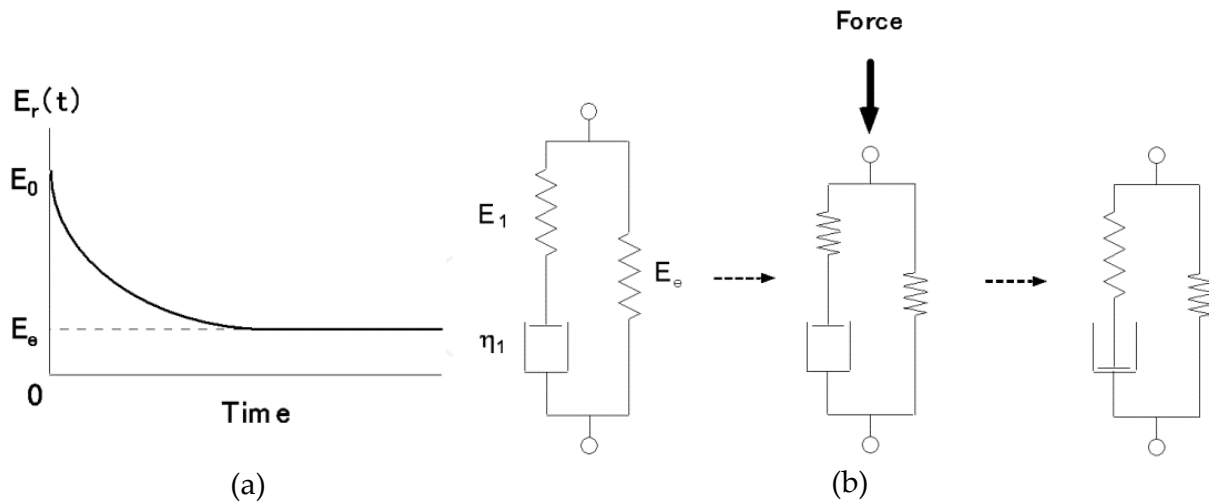

Figure 6. (a) Stress relaxation curve of cross-linked polymers; (b) Three-element model in which one Maxwell element and one spring are connected in parallel (Reference [4]).

E_0 , the steady-flow viscosity η_0 , and η_1 , η_2 of each Maxwell element, respectively, are represented as follows:

$$E_0 = E_1 + E_2 = E_r(0)$$

$$\eta_1 = E_1 \tau_1$$

$$\eta_2 = E_2 \tau_2$$

$$\eta_0 = \eta_1 + \eta_2$$

To make comparison among the materials, the above rheological parameters are used.

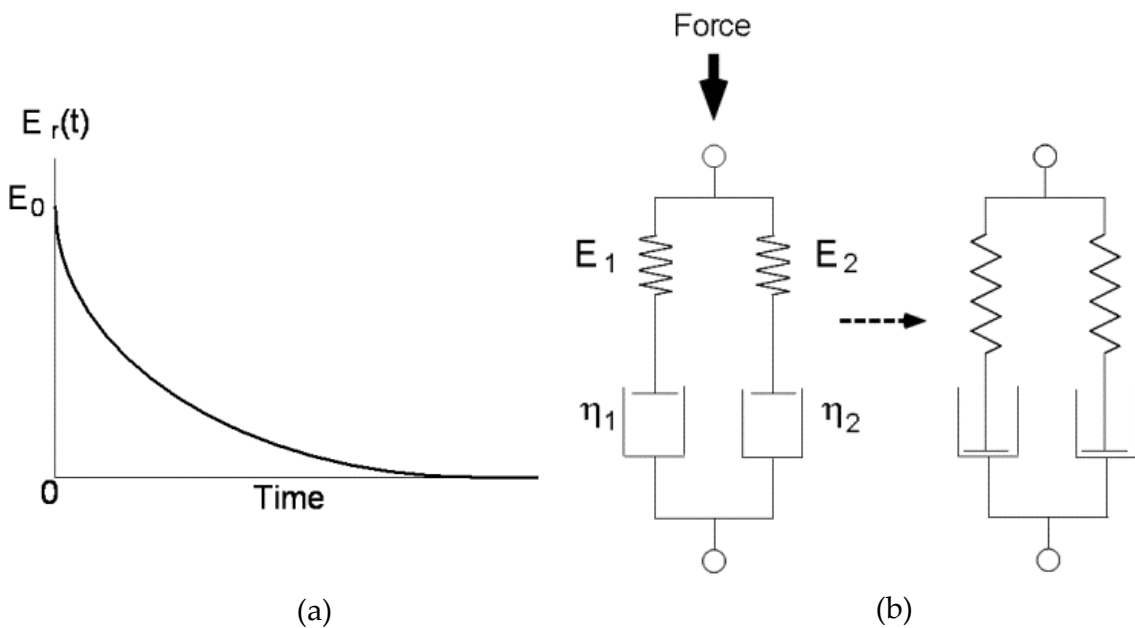

Figure 7. (a) Stress relaxation curve of uncross-linked polymers; (b) Four-element model in which two Maxwell elements are connected in parallel (Reference [5]).

2.3. Dynamic viscoelastic properties

Viscoelastic properties of polymeric materials have been characterized by means of creep test and stress relaxation test. These static measurements have provided valuable information on the materials. However, these methods are not suitable for rigorous evaluation of the rheological characteristics of the materials. Dynamic mechanical test, which measures the response of the material to sinusoidal or other cyclic stresses, is suitable for rigorous evaluation of the rheological characteristics of the materials.

A schematic representation of the relationship between stress and strain, with a sinusoidally varying stress, for a perfectly elastic material, a viscoelastic material and perfectly viscous liquid is shown in Figure 8 to explain analysis of dynamic viscoelasticity [6, 7]. Using a dynamic viscoelastometer, a sinusoidal tensile strain is added to one end of a specimen and the stress response is detected at the other end. For a perfectly elastic solid, the strain is exactly in phase with the stress. For a perfectly viscous liquid, the strain is 90° out of phase. In the case of a viscoelastic material, the strain is somewhere in between ($\pi/2 > \delta > 0$). Amplitude attenuation of the sinusoidal strain and delay of the strain wave are known to be dependent on the viscoelastic properties of the material [1, 6, 7]. The complex modulus E^* , which is determined experimentally by applying a sinusoidal stress, is resolved into two components, i.e. storage modulus E' and loss modulus E'' (Fig 8). E' is the ratio of the stress in phase with the strain to the strain, whereas E'' is the ratio of the stress 90° out of phase with the strain to the strain. E' represents the elastic component of material behavior and it is directly proportional to the energy storage in a cycle of deformation. E'' represents the viscous component of material behavior and it is indirectly proportional to the average dissipation or loss of energy as heat in a cycle of deformation. The tangent of the phase angle (δ) between stress and strain, the loss tangent ($\tan \delta$), is a useful parameter and a measure of the ratio of energy lost to energy stored during cyclic deformation [6].

The complex modulus E^* of each material is calculated as follows [6]:

$$|E^*| = \Delta F / S \times Lt / \Delta L$$

where ΔF is the dynamic load, S the area of specimen, Lt the length of specimen and ΔL the dynamic displacement.

The storage modulus E' and loss modulus E'' , are defined as:

$$\begin{aligned} E^* &= E' + iE'' \\ E' &= |E^*| \cos \delta \\ E'' &= |E^*| \sin \delta \end{aligned}$$

where $i = \sqrt{-1}$. The loss tangent $\tan \delta$ is given by

$$\tan \delta = E'' / E'$$

The rheological parameters of E' , E'' and $\tan \delta$ are often used to evaluate the temperature or frequency - dependence of the materials.

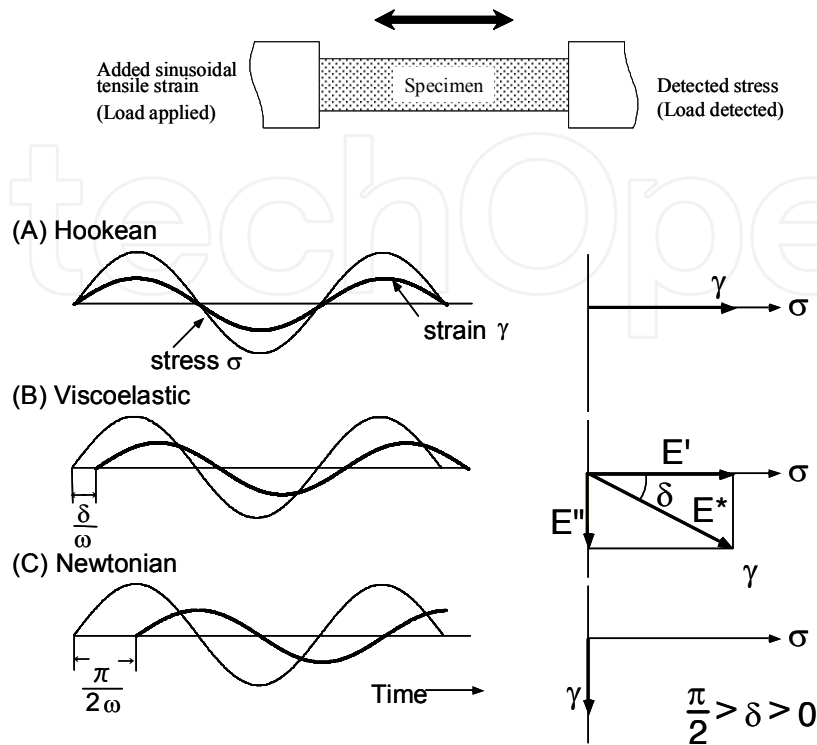

Figure 8. Schematic representation of dynamic mechanical test instrument and relationship between stress and strain of perfectly elastic solid (Hookean body) (A), viscoelastic material (B) and perfectly viscous liquid (Newtonian fluid) (C) with sinusoidally varying stress (Reference [6, 7]).

3. Experimental methods

Experimental methods depend on the condition of materials (liquid, solid, or sol-gel transition).

3.1. Viscoelastic liquid and gelation

There are many methods of measurements for viscoelastic liquid and gelation. In this section, the method by means of rheometer is introduced. An apparatus and schematic representation of dynamic viscoelasticity during the sol – gel transition are shown in Figure 9 and 10, respectively. The rheometer with a parallel plate or cone and plate test configuration is often used in oscillatory mode. The paste was placed on the plate of the rheometer. Torque is monitored at constant oscillating frequency and angular displacement.

In the parallel plate system, the shear strain (γ) and shear stress (τ) are determined experimentally as follows:

$$\gamma = F\gamma\omega$$

$$\tau = F\tau T$$

where $F\gamma$ ($=R/d$) is the shear strain factor; $F\tau$ ($=2/\pi R^3$) the shear stress factor; ω the angular displacement; T the torsional force; R the radius of the plate and d the shear gap.

The complex dynamic shear modulus (G^*), shear storage modulus (G'), shear loss modulus (G'') and loss tangent ($\tan \delta$) are defined as follows [8]:

$$\begin{aligned} |G^*| &= \tau / \gamma \\ G^* &= G' + iG'' \\ G' &= |G^*| \cos \delta \\ G'' &= |G^*| \sin \delta \\ \tan \delta &= G'' / G' \end{aligned}$$

where $i = \sqrt{-1}$, and δ is the phase angle between stress and strain.

G' represents the elastic component of material behavior, whereas G'' represents the viscous component of material behavior.



Figure 9. Controlled-stress rheometer.

Polymers undergo phase transition from liquid to solid at a critical extent of reaction during gelation. The instant of this transition is called the gel point [3]. The polymer is said to be at

the gel point if its steady shear viscosity is infinite and its equilibrium modulus is zero, and at least one chain of infinite molecular weight has been created. The following scaling law at the gel point is suggested [9];

$$G'(\omega) = G''(\omega) \sim \omega^{1/2}$$

At the gel point, G' and G'' are congruent, *i.e.* $\tan \delta = 1$, and this behavior is valid in the entire range $0 < \text{frequency } \omega < \infty$. Thus the gelation time is defined as the time to reach the gel point at which $\tan \delta = 1$ ($G' = G''$) [3, 8, 9] (Fig 10).

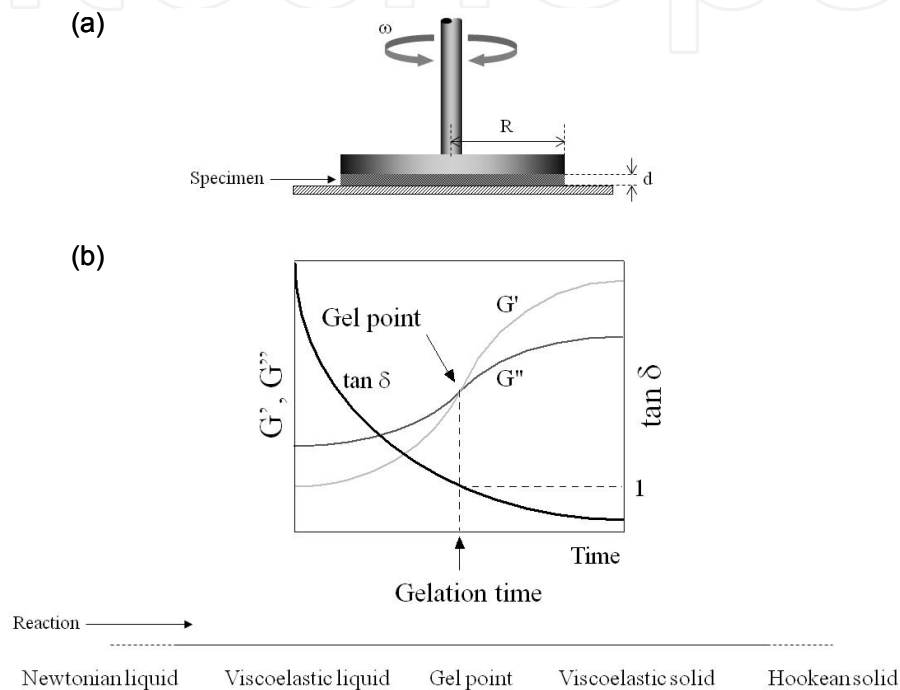

Figure 10. (a) Schematic diagram of a controlled-stress rheometer in a parallel plate configuration; (b) Schematic representation of dynamic viscoelastic properties of gelation system as a function of reaction time (Reference [8]).

3.2. Viscoelastic solids

The dynamic viscoelastic properties of polymeric solids are measured mainly by one of three methods; namely, the free torsional vibration method, resonance forced vibration method and non-resonance forced vibration method. The free damped oscillation of a torsion pendulum is used in the free torsional vibration method. However, this method is limited at the low end of the frequency range (less than 0.1 Hz) due to the effect of air resistance. The resonance forced vibration method also operates most effectively at high frequencies (greater than 10 Hz) and requires large specimens for accurate measurements. The non-resonance forced vibration method overcomes the deficiencies of the other two methods. The method enables the frequency-dependent properties of the polymeric solids to be determined over a wide range of frequencies, such as 0.01 - 100 Hz, and thus allows predictions of behavior under various conditions [6, 10].

One example of dynamic viscoelastometer based on a principle of non-resonance forced vibration is shown in Figure 11. This device consists of a measurement operation block, high/low constant temperature chamber, main unit, power unit, data processing device and testing jigs. The main unit performs high speed analogue-to-digital, digital-to-analogue conversion and transmits input-output signals to the measurement operating block, high/low temperature chamber and data processor. The measurement operating block consists of a magnetic exciter, tension control motor, amplitude detecting sensor and amplifier, load detecting load cell and chucks. During testing a suitable tension is applied to the loaded specimen and the dynamic displacement, i.e. sine wave vibration (sinusoidal stress), is added as a forced power. At the other end of the specimen, the dynamic load is detected and this is converted to familiar rheological parameters such as dynamic strain and dynamic stress, complex dynamic tensile modulus (E^*), tensile storage modulus (E'), tensile loss modulus (E'') and loss tangent ($\tan \delta$) [6].

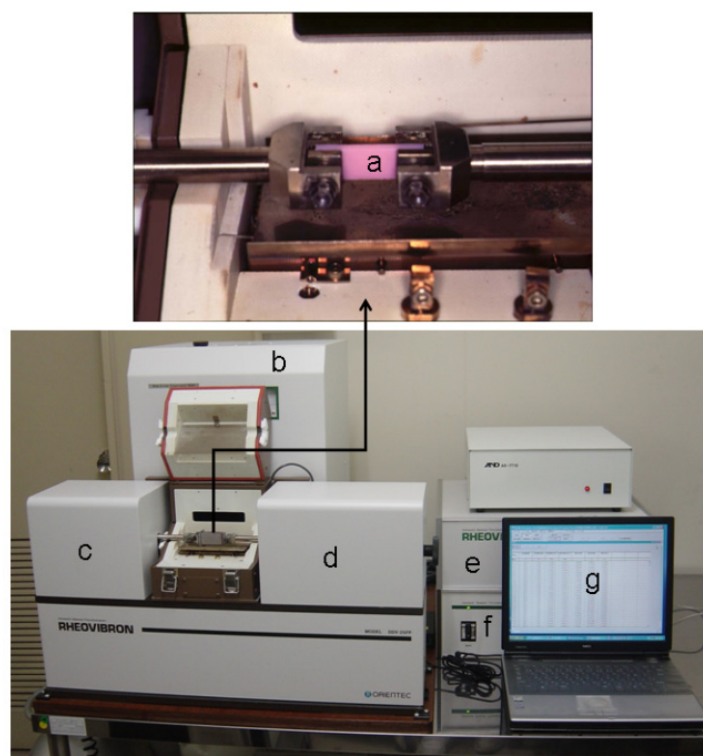

Figure 11. Dynamic viscoelastometer. (a): specimen, (b): high/low constant temperature chamber, (c): driver and displacement detector, (d): load detector, (e): main unit, (f): power amplifier, and (g): personal computer.

4. Rheology in biomaterials

Many biomaterials are available in medicine and dentistry. In this section, rheological properties of dental materials for dentures such as denture base and denture liners are referred (Fig 12). Denture is a removable artificial replacement for one or more teeth carried on a removable plate or frame. Denture liners are of two types, hard denture relines resins and soft denture liners [11].

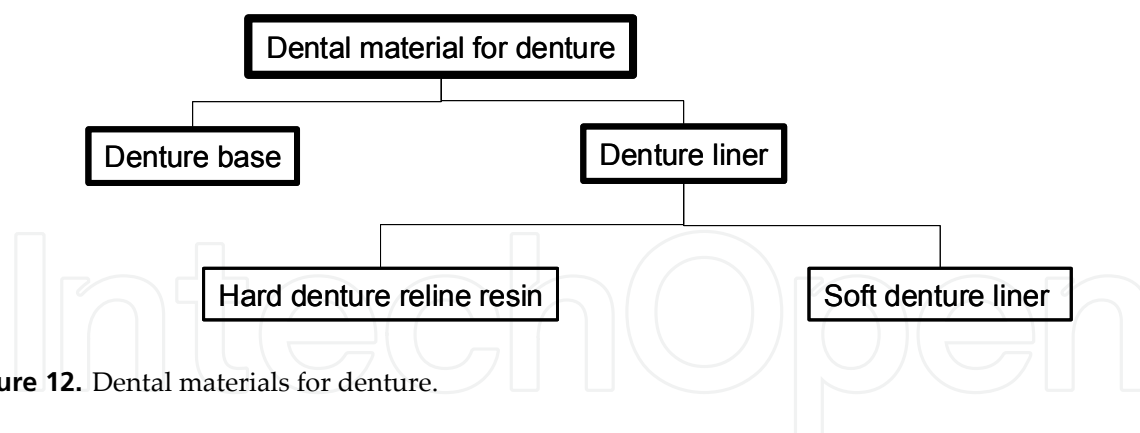

Figure 12. Dental materials for denture.

4.1. Denture base resin and hard denture reline resin

Denture base materials generally consist of heat-polymerized acrylic resins. Hard denture reline resins are used to improve the stability and retention of ill-fitting complete and removable partial dentures. Several types of these resins are available, including autopolymerized and visible light-polymerized materials (Fig 13). Visible light-polymerized, hard denture reline resins can be divided into 2 groups according to the supplied form: a powder-liquid type and a paste-type. Some visible light-polymerized reline resins are dual-polymerized. The powder form of the visible light-polymerized and autopolymerized, powder-liquid type materials consists of poly (ethyl methacrylate), poly (methyl methacrylate), or poly (methyl methacrylate/ethyl methacrylate), along with a peroxide initiator, and pigment. The liquid components are mixtures of methacrylate-based monomers: methyl methacrylate, n-butyl methacrylate, or cyclohexyl methacrylate, along with a cross-linking agent (ethoxylated bisphenol A dimethacrylate or 1,6-hexanediol dimethacrylate). In addition, the liquid forms of the visible light-polymerized materials and the autopolymerized materials include a photoinitiator, such as camphorquinone, and a chemically activated accelerator, such as N,N-dimethyl p-toluidine, respectively. The dual-polymerized materials contain both compounds. The visible light-polymerized, paste-type materials are a mixture of methacrylate copolymers, a polyfunctional monomer (such as urethane dimethacrylate), and a silica filler, which acts as a thickening agent. The differences in composition and structure will influence the mechanical properties of the resulting polymer. Increased cross-linking and microfine silica may result in higher flexural modulus values. The degree of cross-linking of heat-polymerized denture base resins is higher than that of direct denture reline resins. The paste-type materials include the silica filler [2, 7].

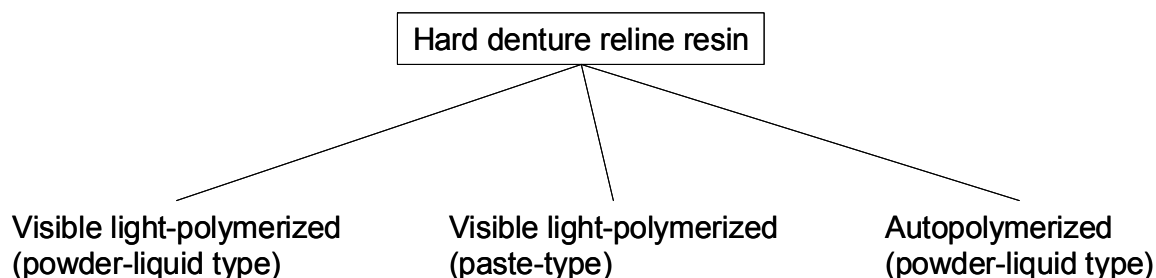

Figure 13. Classification of hard denture reline resins.

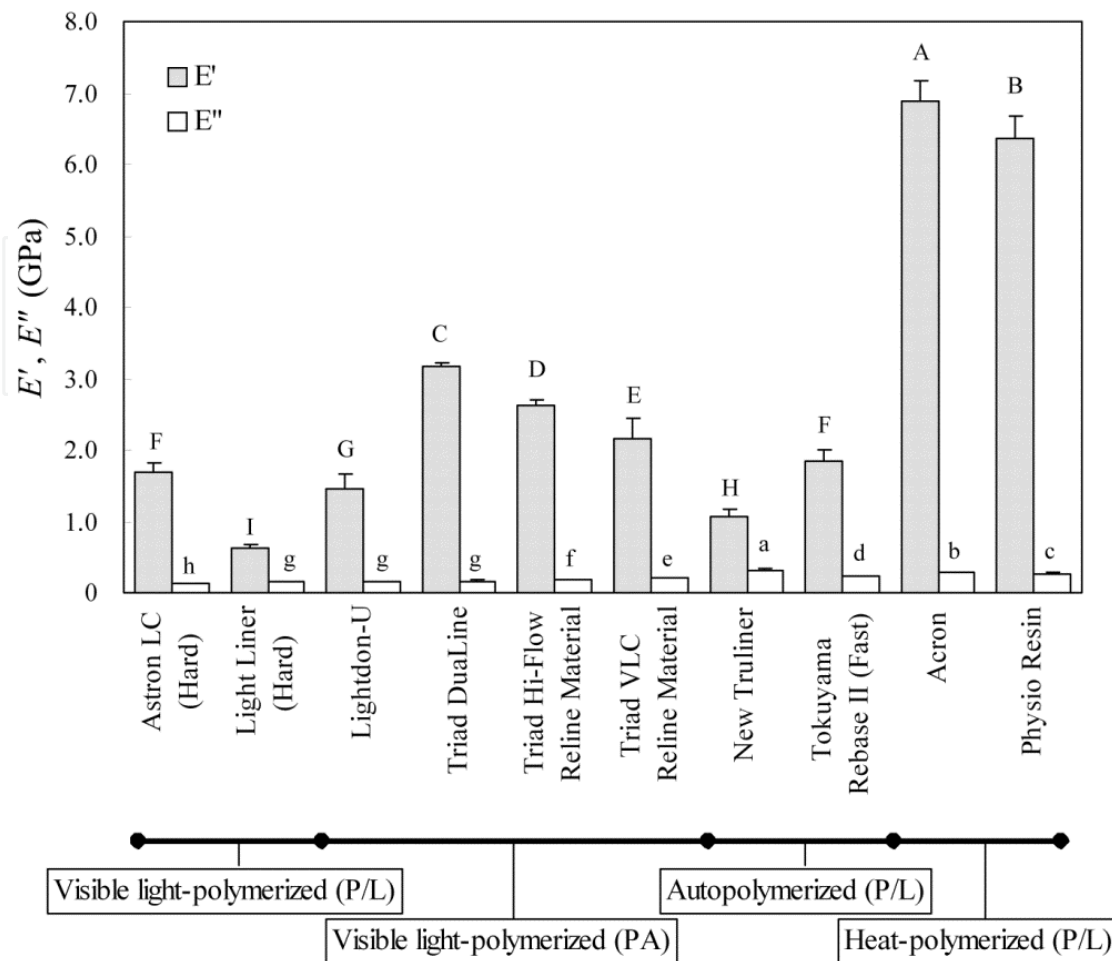

Figure 14. Storage (E') and loss moduli (E'') at 1 Hz of hard denture reline resins and heat-polymerized denture base resins. Within test parameter, values having similar uppercase letters (E') or lowercase letters (E'') are not statistically different. Within each material type, $E' > E''$ (Reference [7]).

The previous study evaluated the dynamic mechanical properties of 8 hard denture reline resins and 2 denture base resins using a dynamic viscoelastometer based on a principle of non-resonance forced vibration [7]. The storage modulus (E') values of 3 visible light-polymerized, paste-type reline resins were significantly higher than those of the other 5 reline resins. However, the E' values of all reline resins were significantly lower than those of the 2 heat-polymerized denture base resins. Except for 1 autopolymerized reliner, all reline materials had significantly lower loss modulus (E'') than the heat-polymerized denture base resins (Fig 14). The loss tangent ($\tan \delta$) values of all visible light (except for 1) and autopolymerized reliners were significantly higher than those of the heat-polymerized denture base materials (Fig 15). It has been found that the visible light-polymerized, paste-type reline resins tend to show greater stiffness than the visible light- or autopolymerized, powder-liquid type reline resins. This finding may be attributed to the presence of silica fillers in these products, which act to reinforce the resin. All of the hard denture reline resins have been also found to exhibit greater flexibility compared to the heat-polymerized denture base resins. Differences in dynamic mechanical properties are most likely due to differences in material composition and character of the resulting polymerized network. For

example, the type, molecular weight and particle size of the polymer powder, the type and content of the monomer and cross-linking agent, and the powder/liquid ratio may all have an influence on mechanical properties of the polymerized material. In the case of the paste-type materials, type, concentration, and particle size of the filler may also have a large influence on the properties. A lower degree of cross-linking and a smaller quantity of silica filler in the reline resins may result in increased flexibility characteristics [7].

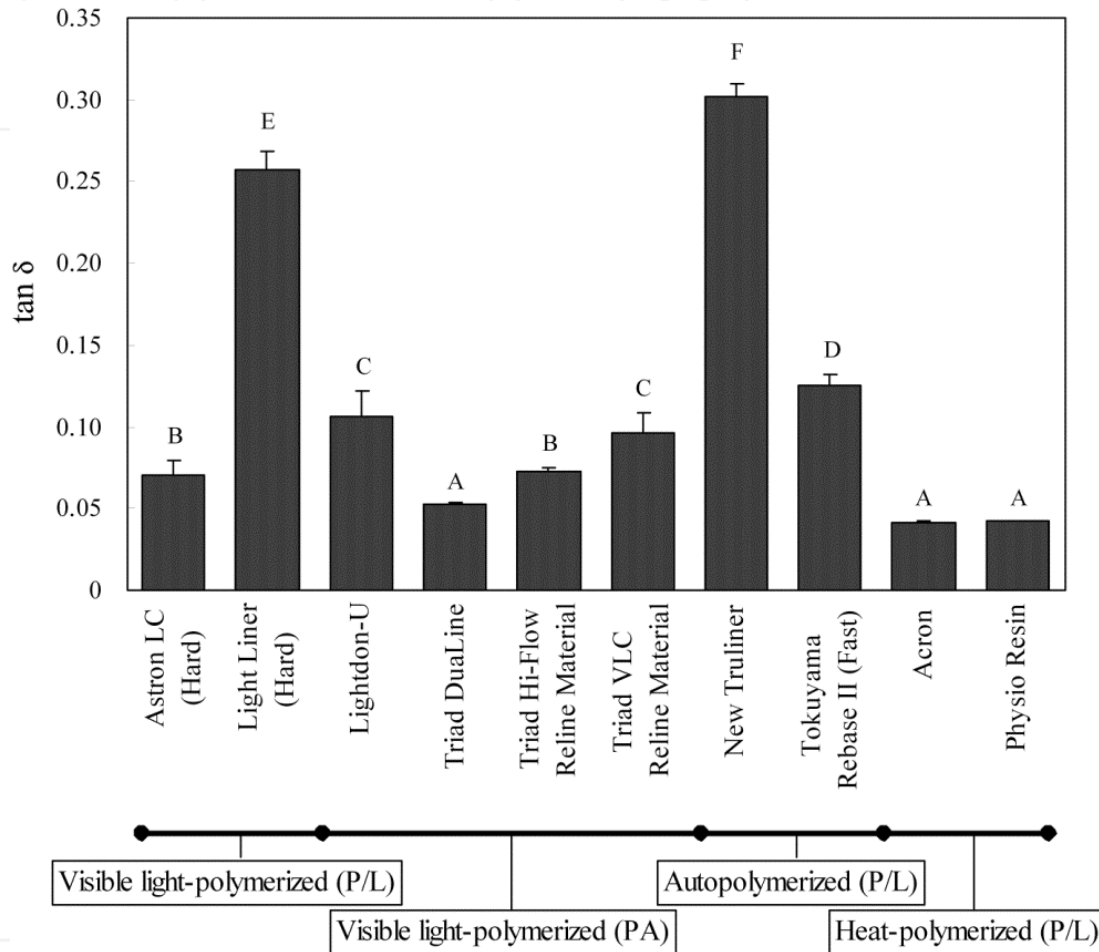

Figure 15. Loss tangent ($\tan \delta$) at 1 Hz for hard denture reline resins and heat-polymerized denture base resins. Within test parameter, values having similar letters are not statistically different. Increase in $\tan \delta$ values indicates material is more able to absorb more energy without elastically returning it, acting more as shock absorber (Reference [7]).

4.2. Soft denture liner

4.2.1. Dynamic viscoelastic properties

Soft denture liners are widely used for denture wearers who complain of masticatory pain. These patients have a thin and non-resilient oral mucosa and/or severe alveolar resorption. These materials are applied to the denture intaglio surface to distribute and absorb masticatory forces by means of the cushioning effect. The clinical effect of the materials is considered to be influenced by viscoelastic properties and durability [11].

Soft denture liners are divided into permanent soft liners and acrylic temporary soft liners (Fig 16). The permanent soft liners can be classified into mainly: (1) autopolymerized silicone, (2) heat-polymerized silicone, (3) autopolymerized acrylic resin, and (4) heat-polymerized acrylic resin. The acrylic temporary soft liner is classified as tissue conditioner [11].

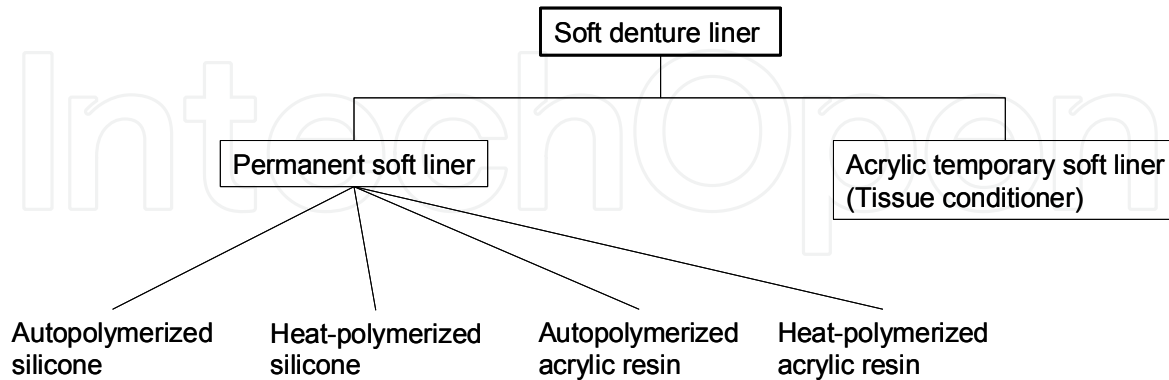

Figure 16. Classification of soft denture liners.

The autopolymerized silicone permanent soft liners are supplied in the form of a two-paste cartridge. These materials are based on a polyvinylsiloxane system. They do not involve the production of by-product such as ethyl alcohol after setting because this setting reaction is the self-curing addition. The heat-polymerized silicone permanent soft liners are supplied as a one-paste system with a free radical initiator. This product consists of a polydimethylsiloxane polymer with pendant or terminal vinyl group that cross-linking occurs [2, 11].

Both the autopolymerized and heat-polymerized acrylic permanent soft liners are supplied as a powder and liquid. The powder generally consists of poly (ethyl methacrylate) or poly (butyl methacrylate) along with some peroxide initiator. The liquid of autopolymerized acrylic material consists of 2-ethylhexyl methacrylate, tertiary amine and plasticizer. Those of heat-polymerized material are a mixture of methyl methacrylate and plasticizer [11].

The tissue conditioner also supplied as powder and liquid components. The main component of the polymer powder of most of the materials is poly (ethyl methacrylate) or a related copolymer. The liquid is a mixture of a plasticizer, such as butyl phthalyl butyl glycolate, dibutyl phthalate and dibutyl sebacate, and ethyl alcohol. Some material based on poly (butyl methacrylate) or a related copolymer contains no ethyl alcohol in the liquids [11].

Tissue conditioners contain no monomers in the liquid and no initiator in the powder. Thus the materials are uncross-linked amorphous polymers. On the other hand, both the silicone and acrylic permanent soft liners are cross-linked amorphous polymers. The differences in structure would influence the clinical behavior of the relined denture [11, 12].

The previous study evaluated the dynamic viscoelastic properties of soft denture liner over a wide range of frequency by a dynamic viscoelastometer (Fig 17) [6, 13]. The dynamic

viscoelastic behavior of the acrylic soft liners showed sensitivity to changes in frequency, while that of the silicone was not markedly frequency dependant. The acrylic soft liners had higher $\tan \delta$ than the silicone soft liners. That is, the acrylic materials demonstrated viscoelastic properties, and the silicones were found to be elastic with $\tan \delta$ approaching zero. Furthermore, the acrylic permanent materials differed from the temporary materials through the nature of the dependence of $\tan \delta$ on frequency. $\tan \delta$ of the acrylic permanent materials increased as the frequency increased from 0.01 to 10 Hz, then decreased again at higher frequencies. Conversely, $\tan \delta$ of the acrylic temporary materials decreased as the frequency increased from 0.01 to 10 Hz, then increased again at higher frequencies. Large differences in dynamic viscoelasticity among the materials are most likely due to the differences in the composition and structure. In high-damping materials and especially at the damping peak, much of the energy to deform a material is dissipated directly into heat [3]. Therefore, $\tan \delta$ is considered to reflect the cushioning effect of the soft denture liners required in the clinical situation [13].

This parameter is also a sensitive indicator of cross-linking [14]. The acrylic temporary materials are formed by polymer chain entanglements of uncross-linked polymers. These entanglements act as temporary and relatively weak cross-links. At temperatures well above the glass transition temperature, damping decreases with an increasing degree of cross-linking. The ability of the acrylic materials, having higher values of $\tan \delta$, to absorb energy and relieve stress will be greater than that of the silicones with lower $\tan \delta$ values [13].

4.2.2. Durability

Changes in dynamic viscoelasticity of soft denture liners over a 3 years period have been determined [6]. The changes in water storage varied markedly among the soft denture liners (Fig 18). The acrylic soft liners exhibited a greater increase in the storage modulus, loss tangent and especially loss modulus with time than the silicone permanent soft liners. The low molecular weight plasticizer contained in the acrylic soft liners is leached out into the water, and, at the same time, water is absorbed into the materials [15]. This will lead to loss of initial viscoelasticity and deterioration in the material conditions. The silicone materials remained stable over time. This would be due to the low water absorption and low solubility of components [16]. From the standpoint of durability, the silicone soft liners are better than the acrylic materials clinically.

4.2.3. Clinical consideration

Relationship between dynamic viscoelasticity and masticatory function has been determined [11,13]. The masticatory function of 10 complete-denture wearers was evaluated by means of maximum bite forces, chewing times and frequencies for test food samples (ham, pickled radish). The patients' subjective assessments of satisfaction with the relined denture were also conducted by means of visual analogue scales (VAS). One acrylic temporary soft liner (tissue conditioner), 1 silicone permanent soft liner and 1 acrylic

permanent soft liner were applied to the mandibular dentures at a thickness of 2 mm. Hard resin-based dentures were also evaluated.

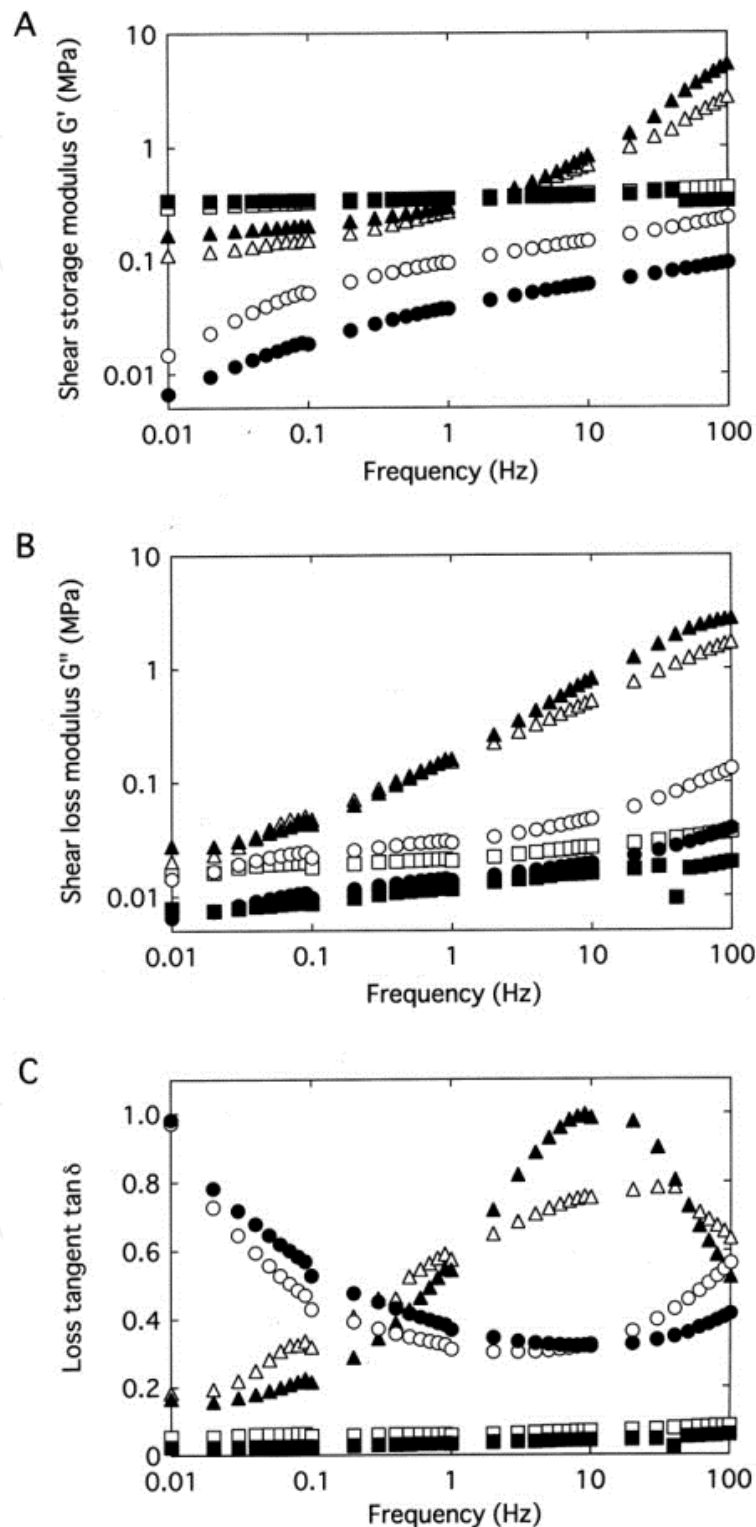

Figure 17. Dependence of storage modulus G' (A), loss modulus G'' (B) and loss tangent $\tan \delta$ (C) on frequency for 6 soft denture liners. Acrylic temporary soft liners A (●) and B (○), silicone permanent soft liners C (■) and D (□), and acrylic permanent soft liners E (▲) and F (△) (Reference [13]).

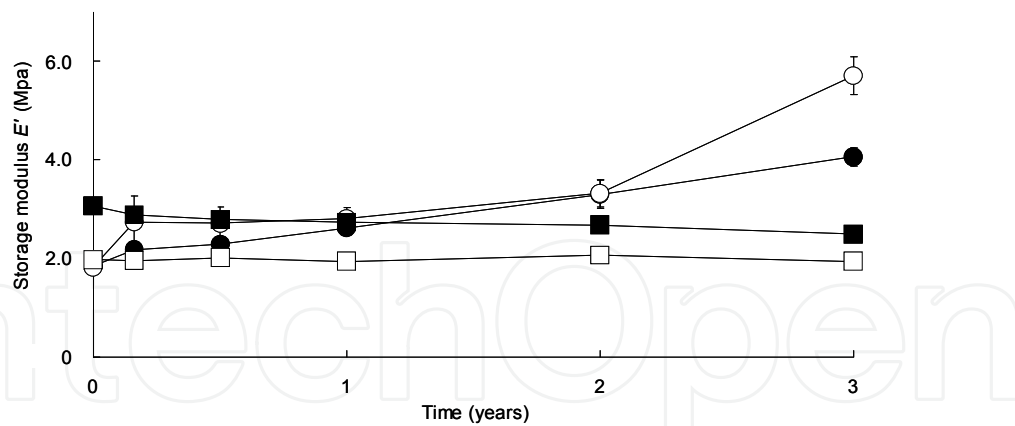

Figure 18. Variation of storage modulus E' with time of storage of 4 soft denture liners at 1 Hz. Acrylic permanent soft liners A (●) and B (○), and silicone permanent soft liners C (■) and D (□) (Reference [6], a part is altered).

Higher maximum bite force and VAS values mean the higher masticatory function. The viscoelasticity of soft denture liners was found to have a great influence on the masticatory function of the complete denture wearers (Fig 19). The greater improvement in masticatory function was observed in dentures lined with the acrylic permanent soft liners, which have higher loss tangent and storage modulus, than in those lined with the silicone permanent soft liners, which have lower loss tangent and higher storage modulus at 1 Hz (Fig 17). The improvement by dentures lined with the acrylic temporary soft liners, which have higher loss tangent and lower storage modulus, was smaller than that by the other soft denture liners.

A higher value of loss tangent (*i.e.*, viscoelastic properties) is likely to exhibit a degree of stress relief under masticatory forces. Theoretically the physical properties of basal seat mucosa should be equal to those of soft denture liners. The Young's moduli E of the oral mucosa was reported to range from approximately 0.4 to 4.4 MPa [17]. E of acrylic temporary soft liners is lower than that of oral mucosa, while E of both acrylic and silicone permanent soft liners is within the range of E for mucosa. Higher storage modulus may produce more ability of instantaneous crush of food by the soft-lined dentures. It was found that the application of a soft denture liner having a relatively high value of both loss tangent (*i.e.*, viscoelastic properties) and storage modulus to the mandibular complete denture leads to the most marked improvement in masticatory function [11, 13].

4.2.4. Sol-gel transition

The influence of composition and structure on dynamic viscoelasticity of concentrated polymer solutions based on poly (ethyl methacrylate) (PEMA) used as acrylic temporary soft liners (tissue conditioners) through the sol-gel transition was evaluated [8]. The acrylic temporary soft liners are concentrated polymer solutions based on PEMA which are applied to the denture intaglio surface to condition abused tissues underlying ill-fitting dentures. The liquid consists of ester plasticizer and ethanol. They are uncross-linked (formed by polymer chain entanglement but not cross-linked), amorphous polymers, formed in situ from the mixture of a polymer powder and a liquid plasticizer. The polymer powder

generally consists of PEMA of molecular weights ranging between 1.79×10^5 and 3.25×10^5 and contains no initiator. The liquid consists of an ester-based plasticizer and 4 - 50 wt% ethanol (EtOH), and contains no monomer. Mixing of the powder and liquid results in polymer chain entanglement and formation of a coherent gel characterized by viscoelastic behavior. The PEMA particles are slowly penetrated by the large molecules of the ester-based plasticizer. The alcohol accelerates plasticizer penetration into the polymer to produce a clinically acceptable gelation time [18].

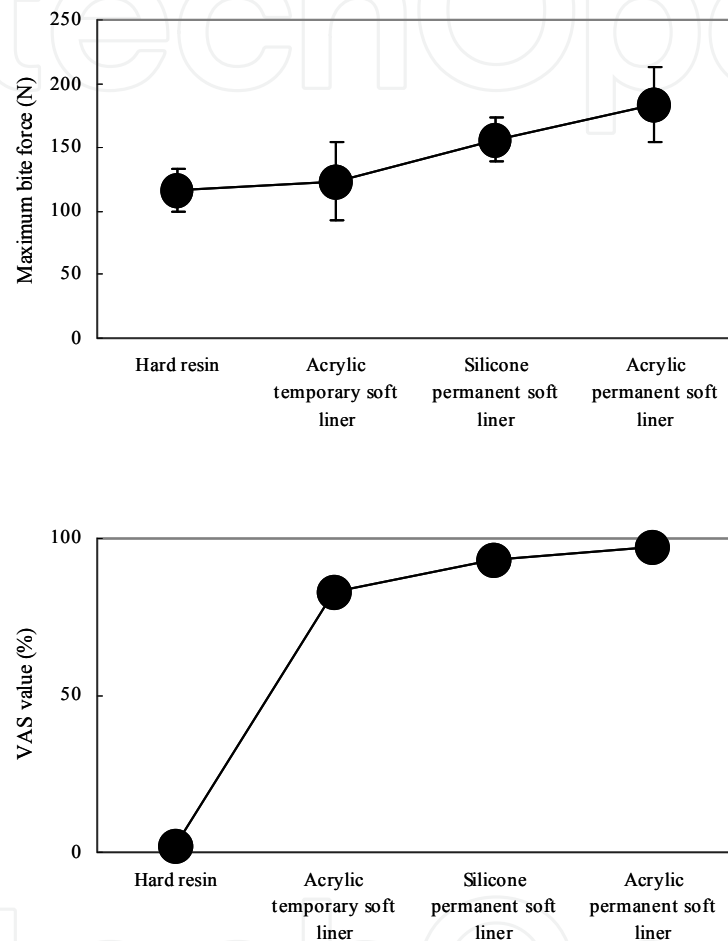

Figure 19. Masticatory function for a subject (Reference [11]).

Four PEMA polymer powders, with weight average molecular weight (M_w) from 1.08×10^5 to 5.30×10^5 were used. The average particle size was approximately $20 \mu\text{m}$ and polydispersity coefficients were approximately 2. Three aromatic esters butyl phthalyl butyl glycolate (BPBG), dibutyl phthalate (DBP) and benzyl benzoate (BB), and an aliphatic ester dibutyl sebacate (DBS) containing ethanol at 2, 5, 10 and 20wt% were used as liquid components. The powder/liquid (P/L) ratio was varied from 0.8 to 1.4 by weight. The various combinations of the 16 different materials were tested to determine the contribution ratio (ρ) of each factor to the gelation times by means of an orthogonal array $L_{16}(4^5)$ (Table 1). Secondly, 26 different materials were used for the determination of the effect of each factor by a one-way layout method [8].

Dynamic viscoelastic properties of the materials during gelation were determined at 37°C. A controlled-stress rheometer was used with a parallel plate test configuration (diameter=20 mm, gap=1000 μm) in oscillatory mode (Fig 9). Torque was monitored every 30 sec at constant oscillating frequency (1Hz) and angular displacement (3 mrad). The complex dynamic shear modulus (G^*), shear storage modulus (G'), shear loss modulus (G'') and loss tangent ($\tan \delta$) were determined. The gelation time was defined as the time at which $\tan \delta = 1$ ($G' = G''$) was reached, that is the gel point [8].

Viscoelasticity of the acrylic temporary soft liners during gelation can conveniently be discussed by dividing the curves of $\tan \delta$ into three regions; region 1, where $\tan \delta$ decreases with time rapidly; region 2, where $\tan \delta = 1$ (the gel point); region 3, where $\tan \delta$ continues to decrease. At the initial stage in region 1, the PEMA polymers dissolve in the plasticizer, and polymer chain entanglements are still scarce. All the solutions are essentially viscous Newtonian fluids. Entanglements then begin to occur and the viscosity gradually increases with time until the solutions can no longer be described as viscous fluids. Before the gel point, although G' is always smaller than G'' , G' increases much more rapidly than G'' and thus $\tan \delta$ decreases rapidly. In the region 2, an infinitely long molecule is produced and the system reaches the gel point (liquid-solid transition), which occurs near where $\tan \delta = 1$. In the region 3, pseudo cross-links consisting of chain entanglements are forming. The materials behave more elastically with increasing reaction time. G' increases rapidly and becomes larger than G'' and thus $\tan \delta$ continues to decrease [8].

The compatibility of different polymers and solvents can be predicted by means of the solubility parameter (SP), which is the square root of the cohesive energy density or vaporization energy (ΔE_v) divided by the molar volume (V):

$$SP = (\Delta E_v / V)^{1/2}$$

In general, polymers and solvents should be mutually soluble when their solubility parameters are equal. It has been reported that a method, which considers solvents as poorly, moderately, or strongly hydrogen bonded, could give relatively accurate predictions of the solubility of a solvent in a polymer (Tables 2 and 3) [12, 19].

The gelation time decreased exponentially with an increase in ethanol content. The higher-molecular-weight polymer powders and a higher P/L ratio produced the shorter gelation times. Among the plasticizers, the shortest gelation time was with benzyl benzoate, and the longest was observed with dibutyl sebacate (Figs 20 and 21). Furthermore, results from the orthogonal array $L_{16}(4^5)$ indicate that the ethanol (strong polar bonding) content ($q=53.8\%$) had more influence on gelation time than the molecular weight of polymer powders ($q=26.7\%$), which in turn had more influence than the type of plasticizer (molar volume) ($q=9.0\%$) and the P/L ratio (concentration of polymers) ($q=4.5\%$). It was found that the gelation, *i.e.*, entanglement speed, of concentrated polymer solutions based on PEMA can be controlled over a wide range by varying the polymer molecular weight and especially ethanol content [8].

No.	Factor Col.	A	B			C	D
		1	2	3	4	5	
1		1	1	1		1	1
2		1	2	2		2	2
3		1	3	3		3	3
4		1	4	4		4	4
5		2	1	2		3	4
6		2	2	1		4	3
7		2	3	4		1	2
8		2	4	3		2	1
10		3	2	4		3	1
11		3	3	1		2	4
12		3	4	2		1	3
13		4	1	4		2	3
14		4	2	3		1	4
15		4	3	2		4	1
16		4	4	1		3	2

Factor	Level				
A: Plasticizer	A ₁ = Butyl phthalyl butyl glycolate		A ₂ = Dibutyl phthalate		
	A ₃ = Benzyl benzoate		A ₄ = Dibutyl sebacate		
B: Ethanol (wt%)	B ₁ = 2	B ₂ = 5	B ₃ = 10	B ₄ = 20	
C: M _w of polymer powders	C ₁ = 1.08 X 10 ⁵	C ₂ = 2.39 X 10 ⁵	C ₃ = 3.75 X 10 ⁵	C ₄ = 5.30 X 10 ⁵	
D: P/L ratio	D ₁ = 0.8	D ₂ = 1.0	D ₃ = 1.2	D ₄ = 1.4	

Table 1. Assignment by Orthogonal Array L₁₆(4⁵). Reference [8]

	Molecular Weight	Viscosity (cP) at 20 °C	Molar Volume (cm ³ /mol)	Solubility Parameter ((J/cm ³) ^{1/2}) ^a
Butyl phthalyl butyl glycolate	336.38	51.3	305.0	20.65
Dibutyl phthalate	278.35	20.3	265.6	19.00
Benzyl benzoate	212.25	8.5	190.5	21.98
Dibutyl sebacate	314.46	10.3	337.1	18.50
Ethanol	46.07	1.2	58.5	26.00

^a The solubility parameter values are those quoted by Reference [12]

Table 2. Characteristics and Solubility Parameters of Plasticizers and Ethanol. Reference [8]

	Solubility Parameter $((J/cm^3)^{1/2})^a$		
	Poorly hydrogen bonded solvent	Moderately hydrogen bonded solvent	Strongly hydrogen bonded solvent
Poly (ethyl methacrylate)	17.4 - 22.7	16.0 - 27.2	19.4 - 23.3
Poly (methyl methacrylate)	18.2 - 26.0	17.4 - 27.2	0

^a The solubility parameter values are those quoted by Reference [12]

Table 3. Solubility Parameters of Polymers for Solution. Reference [8]

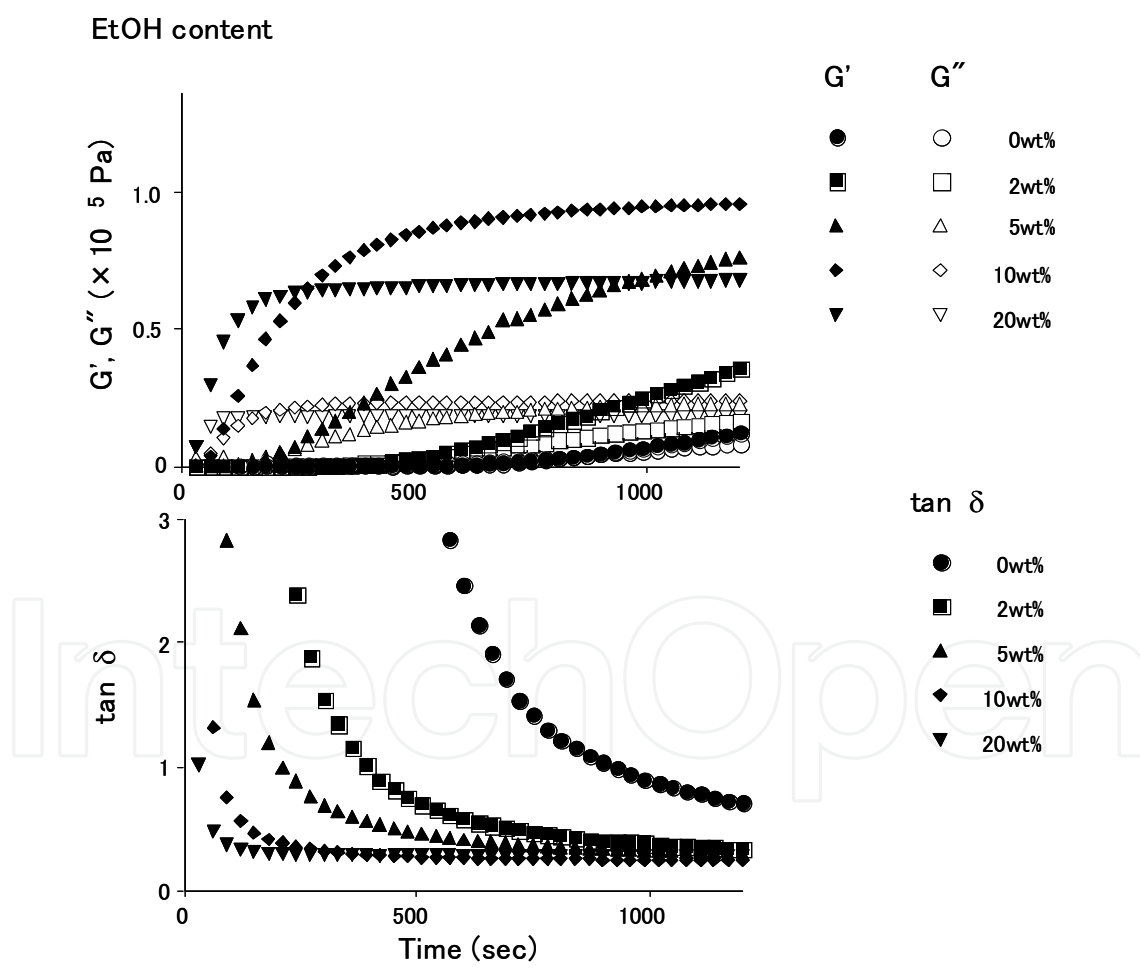

Figure 20. Relationship between variations of G' , G'' and $\tan \delta$ of concentrated polymer solutions based on PEMA with time and ethanol content in liquids (Reference [8]).

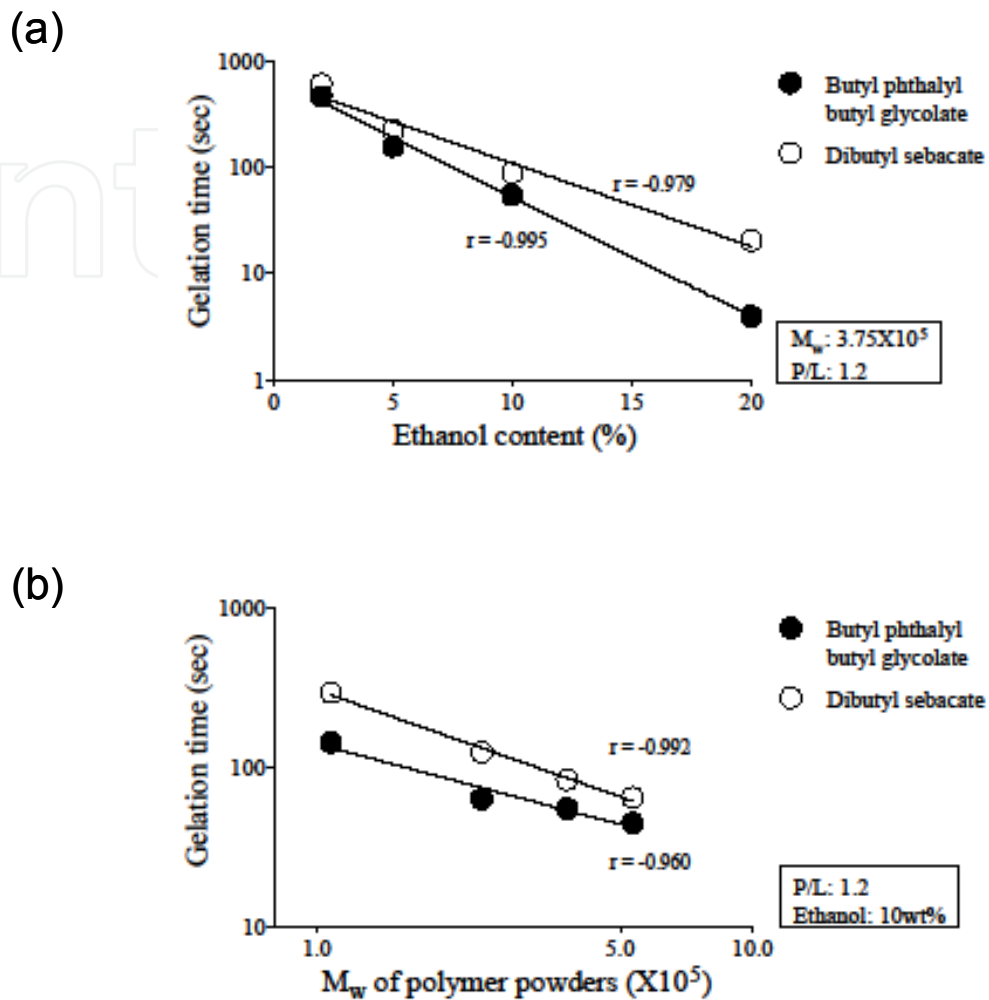

Figure 21. Relationship between gelation times of concentrated polymer solutions based on PEMA, and (a) ethanol content in liquids and (b) molecular weight (M_w) of polymer powders (Reference [8]).

5. Conclusion

In this chapter, basis and theoretical consideration of rheology, and application in biomaterials are described. Rheology will contribute to the science of biomaterials, medicine, dentistry and biology in addition to the polymer science much more.

Author details

Hiroshi Murata

*Department of Prosthetic Dentistry, Graduate School of Biomedical Sciences,
Nagasaki University, Nagasaki, Japan*

6. References

- [1] Ferry JD. (1980) *Viscoelastic Properties of Polymers*. 4th edition. New York: John Wiley & Sons Inc. pp. 1-33.
- [2] McCabe JF. (2008) *Applied Dental Materials*. 9th edition. Oxford: Blackwell Publishing Ltd. pp. 6-21.
- [3] Nielsen LE, Landel RF. (1994) *Mechanical Properties of Polymers and Composites*. 2nd edition. New York: Marcel Dekker Inc. pp. 63-232.
- [4] Murata H, Haberham RC, Hamada T, Taguchi N. (1998) Setting and stress relaxation behavior of resilient denture liners. *J. Prosthet. Dent.* 80: 714-722.
- [5] Murata H, Hamada T, Djulaeha E, Nikawa H. (1998) Rheology of tissue conditioners. *J. Prosthet. Dent.* 79: 188-199.
- [6] Murata H, Taguchi N, Hamada T, McCabe JF. (2000) Dynamic viscoelastic properties and the age changes of long-term soft denture liners. *Biomaterials.* 21: 1421-1427.
- [7] Murata H, Seo RS, Hamada T, Polyzois GL, Frangou MJ. (2007) Dynamic mechanical properties of hard, direct denture reline resins. *J. Prosthet. Dent.* 98: 319-326.
- [8] Murata H, Chimori H, Hamada T, McCabe JF. (2005) Viscoelasticity of dental tissue conditioners during the sol-gel transition. *J. Dent. Res.* 84: 376-381.
- [9] Winter HH, Chambon F. (1986) Analysis of linear viscoelasticity of a crosslinking polymer at the gel point. *J. Rheology* 30: 367-382.
- [10] Clarke RL. (1989) Dynamic mechanical thermal analysis of dental polymers. 1. Heat-cured poly (methyl methacrylate)-based materials. *Biomaterials* 10: 494-498.
- [11] Murata H, Hamada T, Sadamori S. (2008) Relationship between viscoelastic properties of soft denture liners and clinical efficacy. *JDSR.* 44: 128-132.
- [12] Parker S, Braden M. (1990) Formulation of tissue conditioners. *Biomaterials.* 11: 579-584.
- [13] Murata H, Taguchi N, Hamada T, Kawamura M, McCabe JF. (2002) Dynamic viscoelasticity of soft liners and masticatory function. *J. Dent. Res.* 81: 123-128.
- [14] Murayama T, Bell JP. (1970) Relationship between the network structure and dynamic mechanical properties of a typical amine-cured epoxy polymer. *J. Polymer Sci. A2* 8: 437-445.
- [15] Kazanji MNM, Watkinson A. (1988) Soft lining materials: their absorption of, and solubility in, artificial saliva. *Br. Dent. J.* 165: 91-94.
- [16] Kalachandra S, Minton RJ, Taylor DF, Takamata T. (1995) Characterization of some proprietary soft lining materials. *J. Mater. Sci. Med.* 6: 647-652.
- [17] Inoue K, Arikawa H, Fujii K, Shinohara N, Kawahata N. (1985) Viscoelastic properties of oral soft tissue. *Dent. Mater. J.* 4: 47-53.
- [18] Murata H, Toki K, Hong G, Hamada T. (2002) Effect of tissue conditioners on the dynamic viscoelastic properties of a heat-polymerized denture base. *J. Prosthet. Dent.* 88: 409-414.

- [19] Bellenger V, Kaltenecker-Commercon J, Verdu J, Tordjeman P. (1997) Interactions of solvents with poly (methyl methacrylate). *Polymer* 38: 4175-4184.

IntechOpen

IntechOpen