

# We are IntechOpen, the world's leading publisher of Open Access books Built by scientists, for scientists

4,800

Open access books available

122,000

International authors and editors

135M

Downloads

Our authors are among the

154

Countries delivered to

TOP 1%

most cited scientists

12.2%

Contributors from top 500 universities



WEB OF SCIENCE™

Selection of our books indexed in the Book Citation Index  
in Web of Science™ Core Collection (BKCI)

Interested in publishing with us?  
Contact [book.department@intechopen.com](mailto:book.department@intechopen.com)

Numbers displayed above are based on latest data collected.  
For more information visit [www.intechopen.com](http://www.intechopen.com)



---

# Two-Photon Polymerization Fabrication of Doped Microstructures

---

Daniel S. Correa, Leonardo De Boni,  
Adriano J. G. Otuka, Vinicius Tribuzi and Cleber R. Mendonça

Additional information is available at the end of the chapter

<http://dx.doi.org/10.5772/36061>

---

## 1. Introduction

Scientists and engineers have sought to design more compact and efficient devices by means of microfabrication techniques. Examples of microfabrication processes include lithography, chemical vapor deposition, sol-gel, dry etching, among others. Although every technique has its own specificities and advantages, most of them are multi-step processes and demand long time of fabrication. Because of such limitations, and also because of the small range of materials that can be used in these techniques, there has been extensive search for alternative microdevice fabrication methods. A new microfabrication technique, called two-photon polymerization (2PP), emerged in 1997 opening a wider range of material possibilities with the advantage of allowing tridimensional fabrication. In this technique, Maruo et al (Maruo, et al., 1997) employed a laser-based-apparatus to fabricate three-dimensional polymeric microstructures with no topological constrains, high penetration depth without surface modifications and resolution bellow the diffraction limit. This technique usually employs femtosecond laser pulses to promote two-photon absorption (2PA) of a photosensitive molecule dissolved into the bulk of an unpolymerized resin, which creates a radical and triggers polymerization in a confined spatial region.

In a 2PA transition, an atom or molecule is taken to an excited state by simultaneously absorbing two photons in a single quantum event. Considering that 2PA is difficult to be attained by using conventional (low intensity) light sources, normally pulsed laser light is employed. Owing to the nonlinear nature of the 2PA, it displays a quadratic dependence to the light intensity, providing high spatial resolution and low light scattering. As an outcome for a polymerization relied on 2PA, chemical reaction takes place in a tiny focal volume, allowing the fabrication of tridimensional polymeric structures with resolution below the diffraction limit. For instance, two-photon polymerization has already been applied to fabri-

cate micro and nanodevices for a wide variety of applications (Kawata, et al., 2001, LaFratta, et al., 2007, Lee, et al., 2008, Marder, et al., 2007, Sun and Kawata, 2004).

To further enhance the technological potentiality of two-photon polymerization (2PP) to fabricate microstructures, one can dope the basic resin with dyes, nanoparticles, special polymers, and other materials. Such methodology leads to the fabrication of active microstructures with chemical, biological or optical properties, with potential applications in, for instance, optical data storage, photonic crystals, fluorescent and bioactive microstructures (Correa, et al.,2012, Correa, et al.,2009, Cumpston, et al.,1999, Drakakis, et al.,2006, Farsari, et al.,2008, Liska, et al.,2007, Mendonca, et al.,2007, Ovsianikov, et al.,2007, Serbin, et al.,2004, Sun, et al.,2001, Takeyasu, et al.,2008, Tayalia, et al.,2008). In this chapter, we will discuss theoretical and experimental aspects of the two-photon polymerization process, and will review the last advances in the fabrication of doped microstructures. Such microstructures present unique optical, electrical or biological properties (according to the dopant characteristics), desired for technological applications.

## 2. Two-photon absorption: Fundamentals

Two-photon absorption is a process related to the change in the electronic state of an atom or molecule, which is excited from a lower energy level  $|n\rangle$  (ground state, in the most of cases) to a higher electronic state  $|n+1\rangle$ , absorbing simultaneously two-photon of same (called “degenerate process”) or different energies (called “nondegenerate process”). An intermediate virtual state is created from the interaction between the electromagnetic field and matter. Two-photon absorption was theoretically predicted by Maria Göppert-Mayer in 1931 during her doctoral thesis (Göppert-Mayer,1931). Only after thirty years, the experimental observation of the phenomenon became possible, thanks to the invention of the LASER. The first experimental verification of 2PA was confirmed by Kaiser et al, who detected the fluorescence signal emitted by a europium-doped crystal (Kaiser and Garrett,1961), whose electrons were excited via a two-photon transition. Furthermore, this effect was experimentally proved by Isaac Abella (Abella,1962) in 1962, using Cesium vapor as the two-photon absorbing material. Nowadays, two-photon absorption processes have been extensively studied because of the enormous number of technological applications, such as, multiphoton optical limiters, multiphoton fluorescence spectroscopy, as well as multiphoton polymerization. The importance of multi-photon absorption studies is not only restricted to technological applications, but also lies in basic research, which enables to characterize and gather information about different materials. In this field, the quantification of such effect can provide insights on the molecular geometry and electronic charge distribution of an excited molecule. Additionally, two-photon absorption measurements provide properties (symmetry and energy) of some electronic states that can not be seen using traditional spectroscopic experiments.

To promote an excitation by absorption of two photons, the sum of the energies of each isolated photon need to match the energy of the electronic transition, as illustrated in Fig. 1,

for degenerated and nondegenerated cases. Such absorption process is classified as a simultaneous event. According to the uncertainty principle of Heisenberg, however, photons that participate in the transition can have a time interval given by  $h/\Delta E$ , where  $\Delta E$  is the difference of energy between the material's virtual state and the closest real state, and  $h$  is the Planck constant. In other words, the absorption of two photons does not need to be totally instantaneous, once it occurs in an interval given by the Heisenberg principle. Therefore the difference between the virtual and closest real state depends on the energy of the first photon that arrives in the molecule or atom. It means that if the photon presents energy close to the one between the states involved in the transition, according to the uncertainty principle, the 2PA probability will be enhanced.

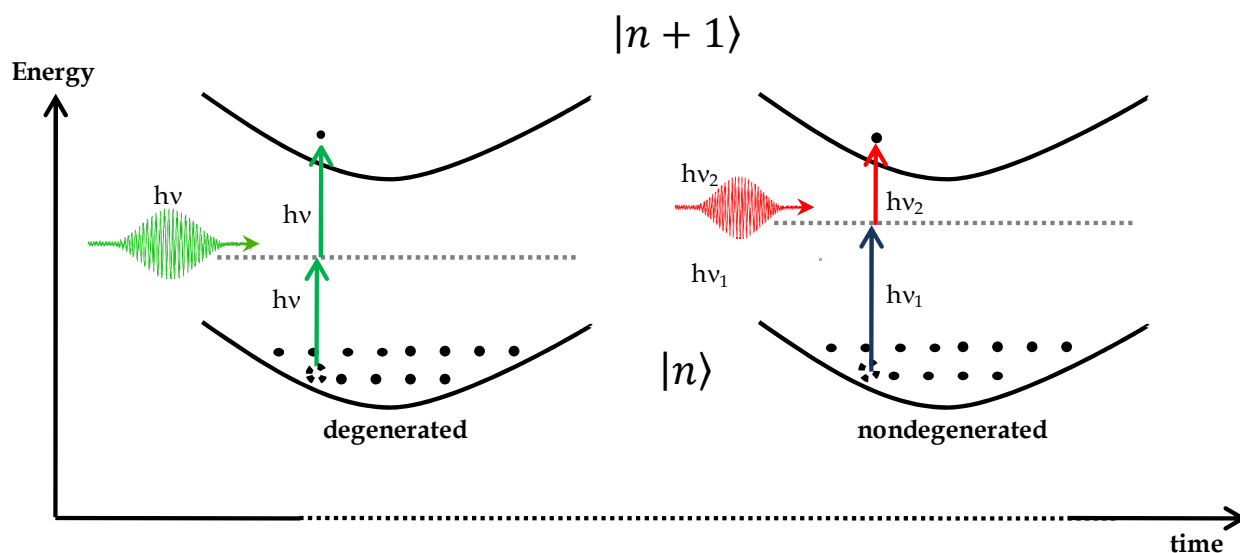

**Figure 1.** Representation of a degenerated and nondegenerated two-photon transition between  $|n\rangle$  and  $|n+1\rangle$  electronic states of an atom or molecule. The dotted lines represent a virtual state which intermediate the two-photon absorption process.

Due to the low probability of the 2PA to occur (compared to conventional one-photon absorption (1PA)), a high number of photons per unit of time and per unit of area is required to reach the atoms or molecules. As the effect exhibits a quadratic dependence on the number of photons, 2PA can be achieved by using ultrashort laser pulses. Once the strength of the two-photon absorption effect is several orders of magnitude smaller than the one-photon one, it is very important that the material presents no linear absorption at the laser wavelength employed.

In order to better understand how the two-photon effect appears in the light-matter interaction, one can imagine that when the electromagnetic field, which interacts with the matter, has a magnitude in the order of the interatomic field, it is able to modify the charge distribution in the material in an anharmonic way. As a consequence, the polarization of the material will be described by nonlinear terms, which are dependent on the incident electromagnetic field. Depending on the phase between the generated polarization and the applied electric field, the results can be either the Kerr effect (Abella,1962) or two-photon

absorption. When two-photon absorption is analyzed from the nonlinear optics point of view, one can see that it is related to the imaginary part of the third-order nonlinear susceptibility,  $\chi^{(3)}$ , (Boyd,1992, Shen,1984), as shown by Eq. 1 (Sheik-Bahae,1990):

$$\text{Im } \chi^{(3)} = \chi_I^{(3)} = \frac{n_0^2 \epsilon_0 c^2}{\omega} \beta \quad (1)$$

in which  $c$  is the speed of light,  $\epsilon_0$  is the vacuum permittivity,  $\omega$  is the photon frequency,  $n_0$  is the refractive index of the material, and  $\beta$  is the two-photon absorption coefficient. Consequently, if the two-photon absorption process is significant, the total light absorption ( $\alpha$ ) of the material is described by:

$$\alpha(I) = \alpha_0 + \beta I_0 \quad (2)$$

where,  $\alpha_0$  is the linear absorption, and  $I_0$  is the light intensity reaching the sample. Equation 2 shows that the two-photon effect becomes more pronounced when the light intensity is considerable high. By using Eq. 2, the attenuation of light intensity as it propagates in the material (represented in Fig. 2), is described by:

$$\frac{dI}{dz} = -(\alpha_0 I_0 + \beta I_0^2) \quad (3)$$

with  $I$  being the light intensity and  $z$  the optical path.

Considering that the material presents negligible linear absorption, the first term on the right side of Eq. 3 can be eliminated. Consequentially, the attenuation of the light will only depend on the two-photon absorption coefficient.

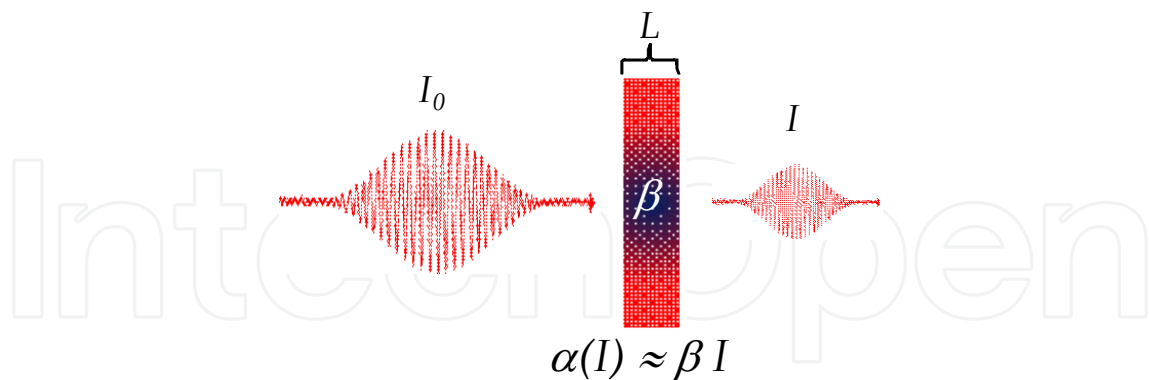

**Figure 2.** Representation of light attenuation when a materials of thickness  $L$  presents a two-photon absorption process.

After some mathematic manipulation, the solution for the attenuation of the light ( $I$ ) due to the two-photon absorption process can be written as:

$$I = \frac{I_0}{1 + \beta L I_0} \quad (4)$$

By Eq. 4, one can see a decrease of the light intensity as the two-photon absorption coefficient increases. This coefficient carries information about the probability of a molecule or atom to absorb two photons simultaneously. In other words, the two-photon absorption coefficient is directly associated with the two-photon absorption cross-section ( $\delta$ ), and is described by Eq. 5:

$$\beta = \frac{\delta N}{h\nu} \quad (5)$$

where,  $h$  is the Planck constant, and  $N$  is the number of absorbers per unit of volume. The molecular two-photon absorption cross-section,  $\delta$ , is usually given in units of Göppert-Mayer (GM), in which, 1 GM is equivalent to  $1 \times 10^{-50} \text{ cm}^4 \cdot \text{s} \cdot \text{photon}^{-1}$ . It is important to mention that similar to the one-photon absorption spectrum, a molecule or atom can present a two-photon absorption spectrum as well. Nowadays, in order to quantify and understand the two-photon absorption cross-sections spectra, monochromatic light sources have been employed. This is normally achieved when optical parametric amplifiers devices are used. In addition, supercontinuum light sources have also been employed to observe the magnitude of this effect (Balu, et al., 2004, De Boni, et al., 2004).

In terms of quantum mechanics analysis, two-photon absorption presents selection rules distinct from one-photon absorption ones. For example, if the molecule is centrosymmetric, one and two-photon transitions for a certain energy level are not allowed at the same time. In other words, one-photon allowed state is not a two-photon allowed one and vice-versa. This arises as a consequence from the angular momentum, which needs to be conserved after the electronic transition. Since photons present spin  $\pm 1$ , one-photon absorption requires that the states involved in the transition differ in its orbital wavefunctions by an angular momentum of  $\pm 1$ . In the same way, for a two-photon transition, the energy levels involved require a change of  $\pm 2$ . This particular characteristic in the quantum mechanics selection rules turns the linear spectroscopy unable to identify two-photon allowed states. In the opposite way, nonlinear spectroscopy, such as two-photon absorption measurements are not able to excite one-photon transitions. On the other hand, when a molecule is not centrosymmetric, the selection rules can be relaxed; enabling the existence of final states reached both by one- or two-photon absorption.

### 3. Two-photon absorption polymerization: Principles and applications

Photopolymerization can be defined as a chemical reaction that turns molecules of low molecular weight (monomers) into macromolecules consisting of repeating units, by using light as the reaction trigger. For one-photon absorption polymerization, the radical species are formed by using a conventional light source (e.g. UV lamp). However, in a two-photon absorption polymerization, electronic transition occurs by simultaneous absorption of two photons, so that radical formation and subsequent polymerization occurs only in the vicinity of the focused light source (laser beam). This results in a small solidified volume (voxel) around the focal spot. By either scanning the laser beam through the resin volume or by



moving the sample in three perpendicular directions (X, Y and Z), arbitrary tridimensional microstructures can be created.

Also, by changing the monomer or the mixture of monomers used in the resin, one can change some characteristics of the final polymer. In this way, it is possible to tailor some properties of the produced microstructure. For example, polymer hardness and the amount of shrinkage the material undergoes due to polymerization can be controlled. Even more, by doping the base resin with different compounds, it is possible to change physical, chemical, biological and optical properties of the final microstructure.

two-photon polymerization microfabrication has a set of unique advantages over conventional microfabrication processes. Because several pulsed laser systems operate in the near infra-red region, where most curable monomers and polymers are transparent, and because two-photon absorption occurs only in defined spatial regions (where light intensity is high enough), it is possible to reach higher light penetration depths. In this manner, this process is able to polymerize, or solidify only a small region in the bulk of the liquid resin, without making any changes to its surface or the surrounding region.

The spatial confinement of the excitation, based on a two-photon process, is illustrated in Fig. 3, which depicts a comparison between one and two-photon induced fluorescence (Marder, et al.,2007) in a liquid sample contained in a silica fused cuvette. Note the fluorescence localization of the two-photon induced process, while one-photon excitation promotes fluorescence along the whole optical path.

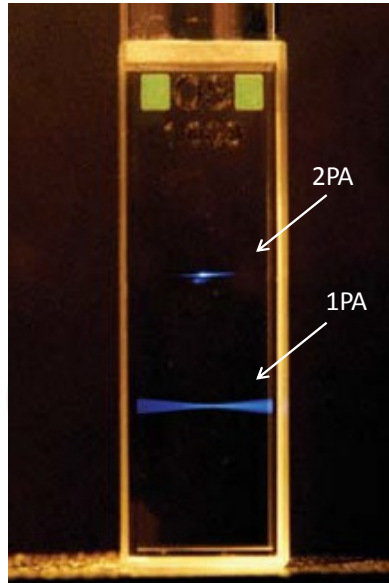

**Figure 3.** Image of induced fluorescence for one and two-photon absorption process (1PA and 2PA). Note the fluorescence localization of two-photon induced processes. Reprinted with permission from (Marder, et al.,2007). Copyright [2007], Materials Research Society.

The resolution in microdevice fabrication technique is of prime importance. The nonlinear nature of two-photon polymerization allows for localized excitation and gives a fine resolution to this fabrication method. In fact, the two-photon absorption process pushes the fabri-

cation resolution below the diffraction limit. All optical systems resolutions are limited by its optical instruments diffraction. The diffraction limit is the fundamental maximum resolution that any optical system can achieve. The minimum spot size that can be achieved is given by Abbe's expression (Fowles,1989):

$$r = \frac{0.61\lambda}{NA} \quad (6)$$

where,  $r$  is the focal spot radius,  $\lambda$  is the light wavelength, and  $NA$  is the numerical aperture of the system. The numerical aperture is a number defined by Abbe as:

$$NA = n \sin(\theta) \quad (7)$$

where,  $n$  is the index of refraction in the focusing medium, and  $\theta$  is the convergence angle of the beam. Figure 4 shows a schematic diagram for objectives with different  $NA$ .

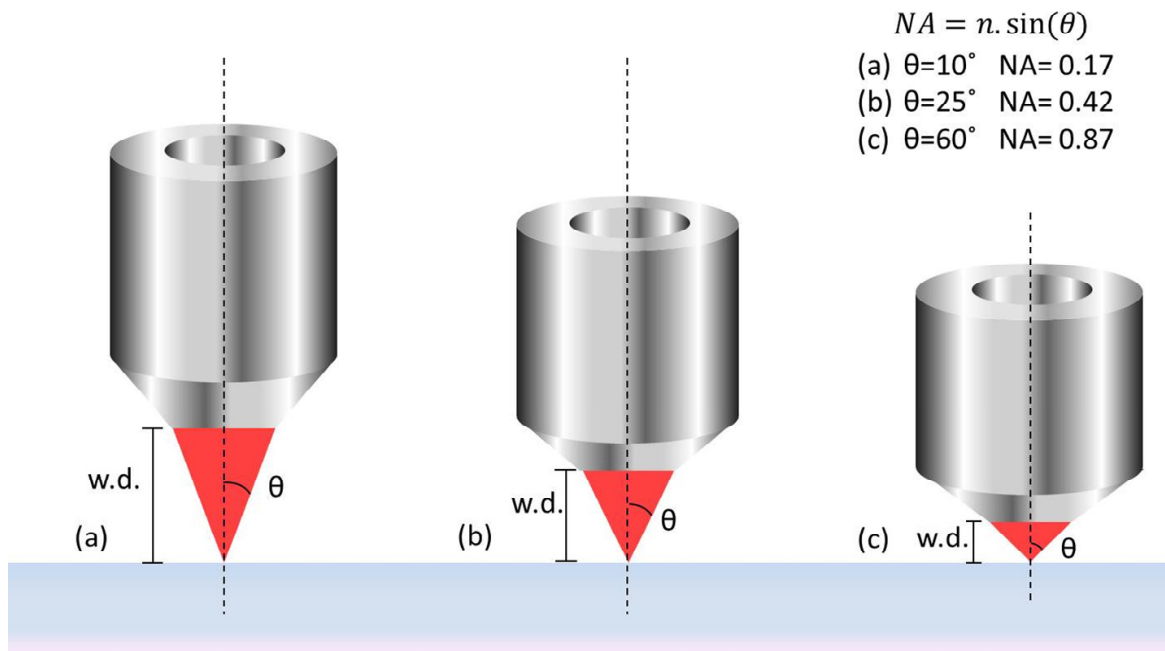

**Figure 4.** Light focusing through microscope objective lens with different  $NA$ . W.D. stands for working distance.

The greater the numerical aperture, the smaller the working distance, i.e., the distance between the focal plane and the surface of the objective, according to Fig. 4. However, Abbe's equation works for plane waves only. Since most pulsed lasers have an approximately Gaussian beam profile, the minimum beam waist is given by:

$$w_0 = \frac{\lambda}{\pi NA} \quad (8)$$

where  $w_0$  is the beam waist at the focal plane. The beam waist is defined as the distance from the center of the Gaussian beam up to the point where the amplitude of the electric field falls down to  $1/e$  of its maximum. However, Eq. 8 is still an approximated value; it works well for



small  $NA$  optics ( $NA \ll 1$ ). Generally, however, two-photon polymerization setups use high numerical aperture optics, such as microscope objective lenses. For high numerical aperture systems, such as immersion microscope objectives, a more accurate expression would be:

$$w_0 = \frac{\lambda}{\pi NA} \sqrt{n^2 - NA^2} \quad (9)$$

Equation 9 shows that the smallest feature that one system can produce is limited by the microscope objective lens numerical aperture and by the wavelength. Nevertheless, once two-photon absorption rate is proportional to the square of the incident beam intensity and, therefore, depends on the squared Gaussian intensity profile, the beam presents a narrower waist than the one defined by Eq. 9.

Figure 5 shows the difference between a Gaussian and a squared Gaussian beam profile. Therefore, due to the nonlinear nature of this process, it is possible to achieve resolution below the diffraction limited spot size. This phenomenon reduces the beam waist by a factor of  $\sqrt{2}$ . In addition to the square dependence, there is still another phenomenon that can yield even better resolution to two-photon polymerization process, which is the polymerization threshold. The polymerization threshold imposes a minimum power below which, even if the sample is irradiated, no polymerization takes place. This phenomenon usually occurs due to the presence of oxygen in the resin. Molecular oxygen inhibits the action of the photoinitiator radicals, preventing the polymerization reaction from occurring. Although this might be a problem for polymer film curing, it can be used as an advantage in the two-photon polymerization fabrication, in the sense that it can decrease even more the polymerized voxel size.

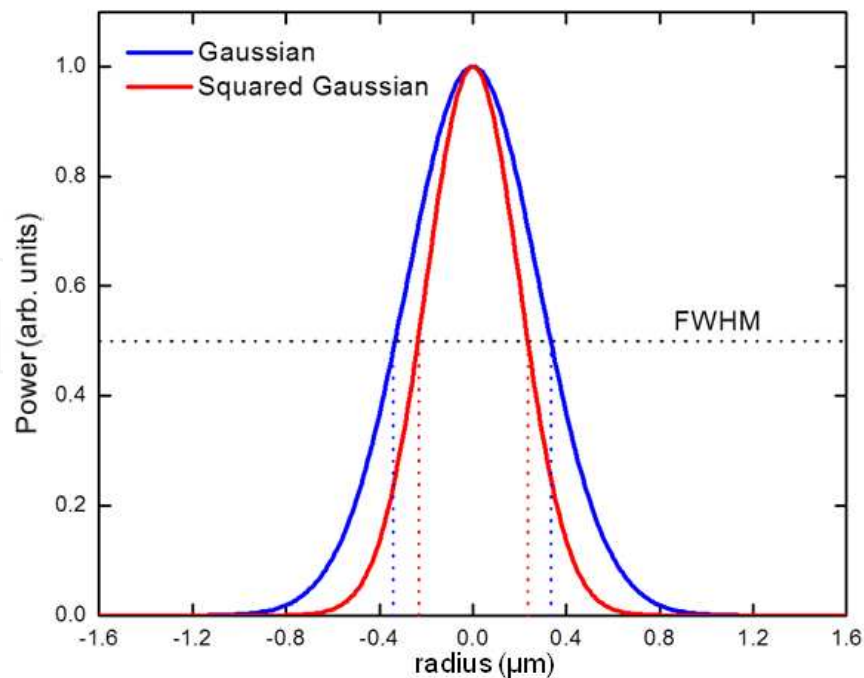

**Figure 5.** Gaussian and squared gaussian beam intensity profile. For comparison, it is also displayed (dotted line) the laser beam full width at half maximum (FWHM).

For a Gaussian profile, the central part of the beam is more intense than its borders. Therefore, even though the outer regions of the beam might not have enough power to start the reaction, the central part of the beam can overcome the threshold. It is important to realize that polymerization will also be contained in the Z direction. Equation 10 shows the intensity envelope of a Gaussian beam in cylindrical coordinates:

$$I(r, z) = I_0 \frac{w_0^2}{w(z)^2} e^{-2\left(\frac{r}{w(z)}\right)^2} \quad (10)$$

If we consider the laser beam waist at the focal plane and its intensity profile, only the central part of it will effectively solidify the resin. The beam waist (radius) at the focal plane is  $w_0$  and it grows with Z (distance from the focal plane) as:

$$w(z) = w_0 \sqrt{1 + \left(\frac{2\lambda}{\pi n w_0^2}\right)^2} \equiv \sqrt{\frac{\lambda}{\pi n} \left( z_R + \frac{z^2}{z_R} \right)} \quad (11)$$

where  $\lambda$  is the wavelength,  $n$  is the index of refraction and  $z_R$  is the Rayleigh length, defined as the distance from the focal plane in which the beam waist increases by a factor of  $\sqrt{2}$ . The Rayleigh length can be written as:

$$z_R = \frac{\pi n w_0^2}{\lambda} \quad (12)$$

If we set  $I(r, z) = I_{th}$  in Eq. 5, (*th* stands for threshold) we can obtain the diameter ( $D$ ) and the length ( $L$ ) of the focal region where the intensity exceeds the threshold value (Juodkazis, et al., 2005), according to:

$$D(r) = w_0 \sqrt{2 \ln \left( \frac{I(r)}{I_{th}} \right)} \quad (13)$$

$$L(z) = 2z_R \sqrt{\left( \frac{I(z)}{I_{th}} \right) - 1} \quad (14)$$

As the two-photon absorption process depends on the square of the intensity and therefore on the focal volume in which the polymerization reaction in fact occurs, the diameter ( $D$ ) and length ( $L$ ) will be smaller. The dimensions of the polymerization voxel for two-photon polymerization should be written as (Juodkazis, et al, 2005):

$$D(r) = w_0 \sqrt{\ln \left( \frac{I(r)}{I_{th}} \right)} \quad (15)$$

$$L(z) = 2z_R \sqrt{\left(\frac{I(z)}{I_{th}}\right)^{1/2} - 1} \quad (16)$$

By controlling laser power in order to have it near the polymerization threshold value, it is possible to create structures with resolution well below the diffraction limit. Figure 6 illustrates how polymerization threshold can yield further improvements in fabrication resolution regardless of the optical system. These are some of the characteristics that made two-photon polymerization microfabrication technique so appealing for many research groups in the last decade.

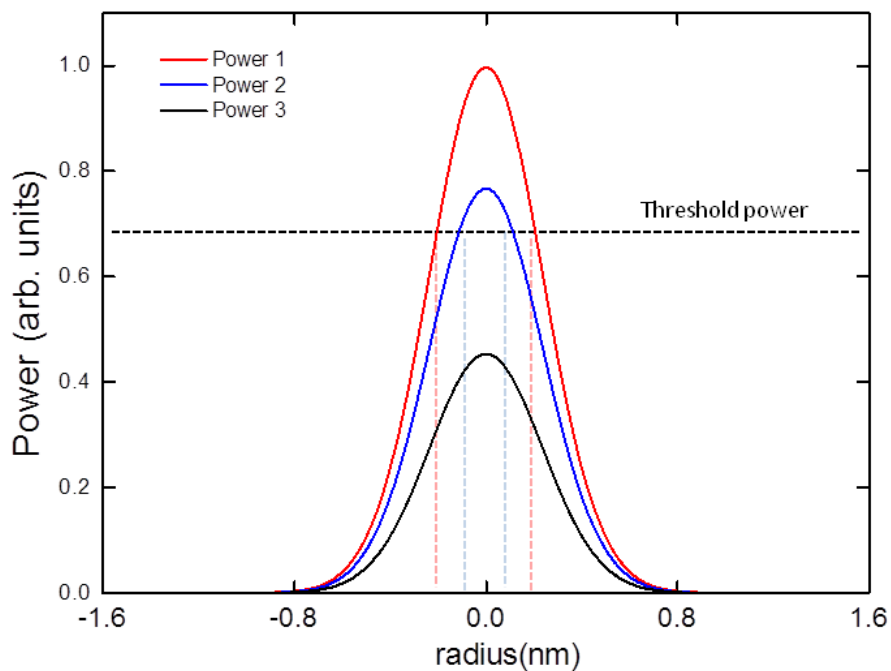

**Figure 6.** Threshold power relative to various gaussian profiles. The more the peak power gets closer to the threshold power the smaller is the voxel size. Polymerization is not observed if peak power is below the threshold power.

The first two-photon polymerized microstructures were reported by Maruo et al (Maruo, et al.,1997) and date back to 1997. In that work, their intention was to demonstrate the capabilities of this new fabrication technique. No other process offers both, complex tridimensional fabrication and resolution below the diffraction limit. In order to illustrate such features, Kawata et al (Kawata, et al.,2001) used a computer model and created a micro sculpture of a bull with subdiffraction-limit resolution. In addition, to show that the microstructures retained good structural and physical properties, they fabricated a micro spring attached to one cube and demonstrated its oscillation. Figure 7 (a) and (b) shows both structures.

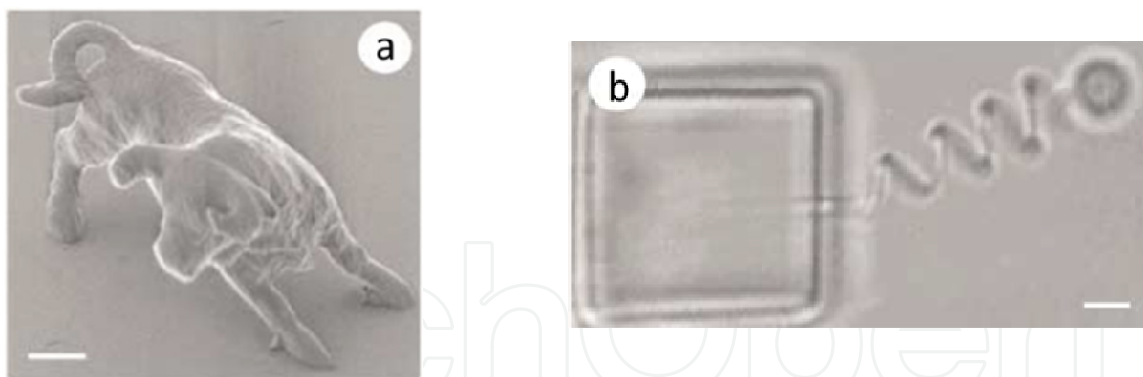

**Figure 7.** Micro sculpture of (a) a bull and (b) oscillating spring system. Scale bar is 2µm. Reprinted with permission from (Kawata, et al.,2001). Copyright [2001], Nature Publishing Group.

#### 4. Materials employed and experimental setup

The polymeric resins employed for two-photon absorption polymerization vary widely. For instance, Maruo et al reported the use of urethane acrylate monomer (Maruo, et al.,1997), Baldacchini et al (Baldacchini, et al.,2004) and Haske et al (Haske, et al.,2007) used a mixture of two-acrylic resin, while Chichkov's group employed Inorganic-organic hybrid polymers (Schlie, et al.,2007, Serbin, et al.,2004). Our group has used the same resin formulation proposed by Baldacchini et al (Baldacchini, et al.,2004), whose formulation consists of a mixture of two tri-acrylate monomers (see Fig. 8): (a) tris(2-hydroxyethyl)isocyanurate triacrylate and (b) ethoxylated(6) trimethylolpropane triacrylate. The first one increases the microstructure hardness, while the second one reduces shrinkage upon polymerization. Ethyl-2,4,6-trimethylbenzoylphenylphosphinate, commercially known as Lucirin TPO-L, has been used as the photoinitiator, due to its favorable two-photon absorption properties (Baldacchini, et al.,2004, Mendonca, et al.,2008). The chemical structures of the two acrylic resins and the photoinitiator are displayed in Fig. 8 (a), (b) and (c) respectively.

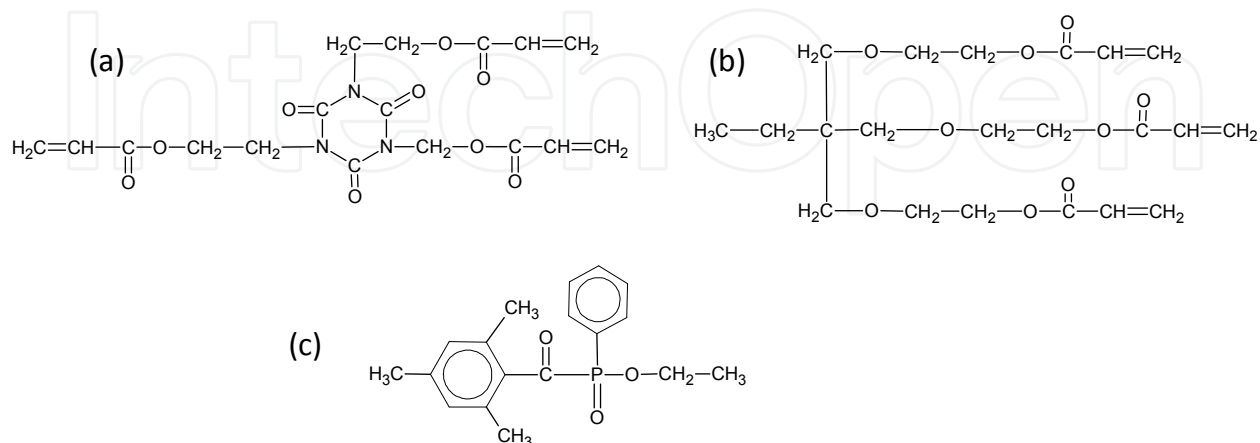

**Figure 8.** Chemical structures of materials used in the two-photon polymerization. (a) tris(2-hydroxyethyl)isocyanurate triacrylate and (b) ethoxylated(6) trimethylolpropane triacrylate and (c) Ethyl-2,4,6-trimethylbenzoylphenylphosphinate (photoinitiator).

The experimental setup used in two-photon polymerization typically employs femtosecond lasers and pulse energies of nanojoules. Although the average energy is low, the pulse peak intensity is high enough to promote two-photon absorption polymerization. In our specific case, we use a Ti:sapphire laser oscillator system, which delivers pulses of 100 fs centered at 800 nm. The laser beam is focused onto the resin to be polymerized by using a 0.65-NA microscope objective. The average power used depends on the nature of the materials employed (such as type of polymeric resin, photoinitiator, dopants etc), once it must be high enough to overcome polymerization threshold, but low enough to avoid material degradation. We typically employ pulse energies in the order of 0.1 nJ, measured before the objective. The sample preparation consists in placing a drop of the resin on a substrate (glass slide) previously cleaned. The resin is retained between spacers and enclosed by a cover slip, as illustrated in Fig. 9.

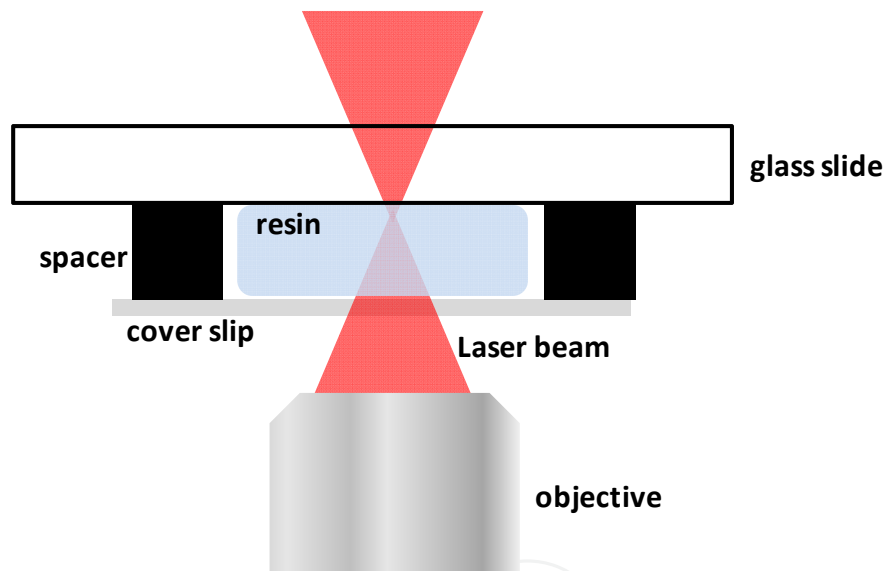

**Figure 9.** Scheme of sample preparation, where the resin to be polymerized by the laser beam is placed between a glass slide and a cover slip, separated by spacers.

The sample is then positioned and moved in the axial  $z$  direction using a motorized stage, while the laser beam scans the sample across the  $xy$  plane, by using a pair of galvano mirrors. In addition, a CCD camera is coupled to the experimental setup to monitor two-photon absorption polymerization in real time. An illustration of the two-photon polymerization experimental setup is displayed in Fig. 10.

After the desired microstructure is fabricated, the sample is immersed in ethanol to wash away the unsolidified resin, leaving behind solely the desired microstructure on the glass substrate, according to the scheme sequence depicted in Fig. 11.

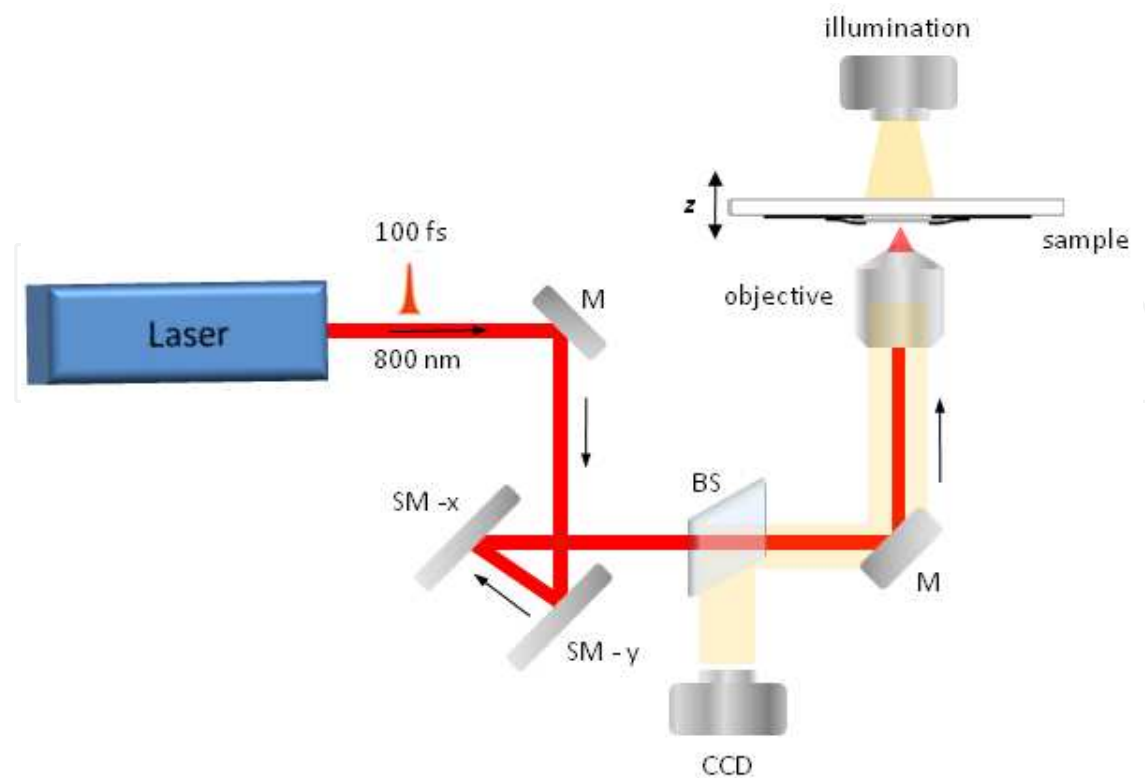

**Figure 10.** Scheme of the experimental setup employed for the two-photon absorption polymerization. M, BS, SM-x and SM-y stands for mirror, beam splitter, scanning mirror in x and y direction, respectively.

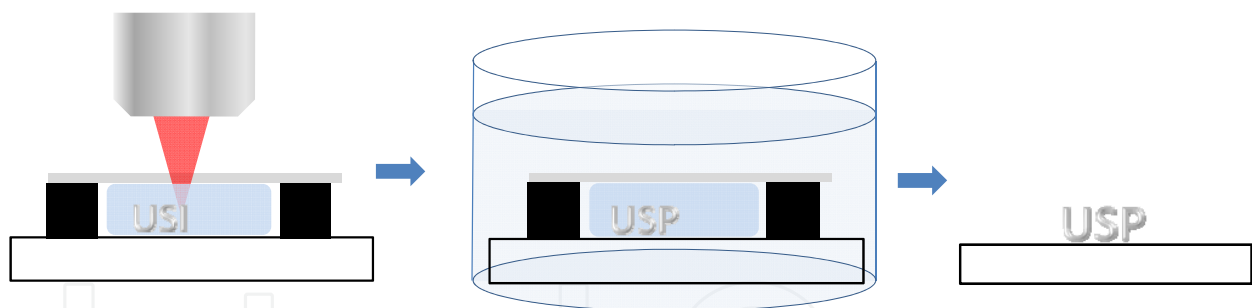

**Figure 11.** Scheme of the sample washing with ethanol after microfabrication to remove the unpolymerized resin.

## 5. Doped microstructures and applications

Most of the initial studies reporting microfabrication of structures via two-photon absorption polymerization dealt with undoped microstructures. Although in this case the structures still present high definition and functionality, the final structures are of limited application, once the properties cannot be probed or altered by external sources. In the last few years, however, several research groups have attempted to dope the resin formulations with a large variety of advanced materials, aiming at giving new functionalities to microstructures, such as chemical, biological or optical properties. Next we will present some results that diverse research groups have obtained by using methodologies to



incorporate distinct dopants in the resin formulations, aiming at obtaining two-photon polymerized microstructures with unique properties for technological applications.

- *Incorporation of conjugated polymers*

Conjugated polymers are materials of great interest to be used in technological devices, once the electron delocalization along the polymer backbone can render them conductivity and nonlinear optical properties. For instance, in a methodology proposed by our group (Mendonca, et al.,2009), poly (2-methoxy-5-2-ethylhexyloxy-1,4-phenylenevinylene) (MEH-PPV), widely known for its conductivity (Yu, et al.,1995), electroluminescence (Nguyen, et al.,2000, Parker,1994), and nonlinear optical properties (Chung, et al.,2002, Correa, et al.,2007, De Boni, et al.,2004, Oliveira, et al.,2006) has been incorporated into the basic resin in a guest-host strategy. In the proposed methodology, the host consists of the two triacrylate monomers and the photoinitiator displayed in Fig. 8. To this solution, it is added up to 1.5% of MEH-PPV, which was then mixed up for 2 hours. Ethanol was eliminated by evaporation at room temperature for 24 h, yielding a viscous liquid. From this liquid, we extracted some drops and place on the glass substrate, as illustrated in Fig. 9.

Two-photon absorption polymerization was employed to fabricate waveguides containing MEH-PPV, using as substrates mesoporous silica films, which have a low refractive index ( $n = 1.185$ ) throughout the visible spectrum and, therefore, minimize waveguiding losses (Konjhdzic, et al.,2005). Figure 12 (a) shows a fluorescence microscopy top view image of 100  $\mu\text{m}$ -long waveguide fabricated on a mesoporous silica substrate, illuminated in its central region by a CW laser beam at 532 nm. The MEH-PPV fluorescence is guided through the microstructure and scatters at both microstructure ends. When the experiment was carried out in waveguides fabricated on top of a conventional glass slide, no waveguiding was observed due to light coupling to the substrate. Figure 12 (b) displays a side view scheme of the microstructure excitation and the corresponding waveguiding. Such waveguide is promising to be used in photonics applications such as microLEDs.

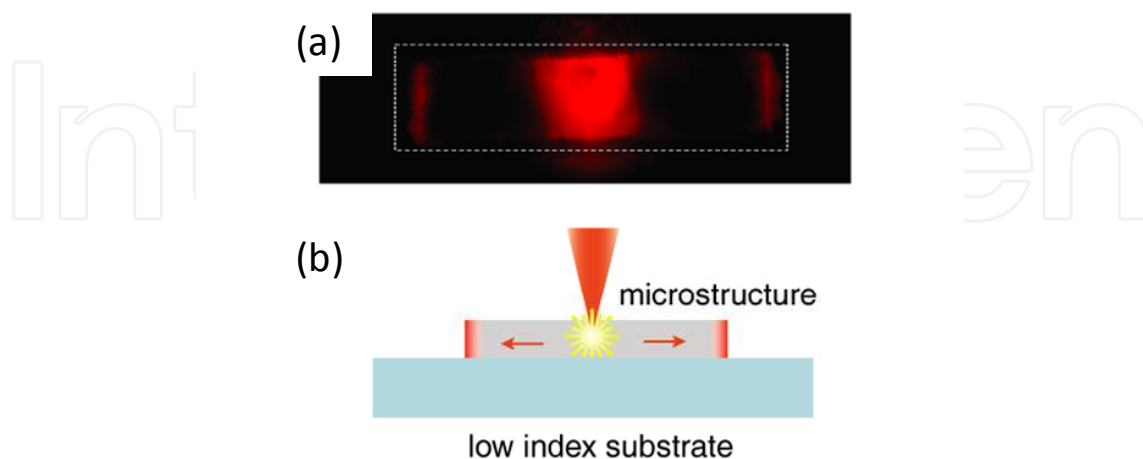
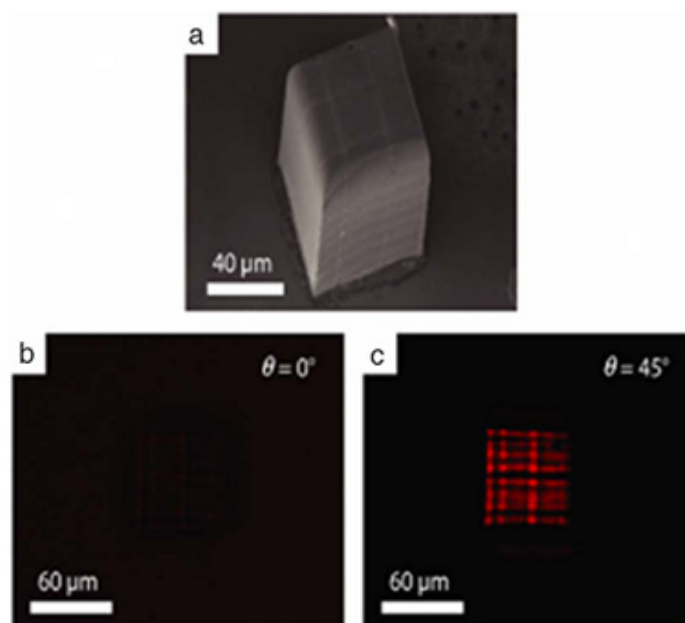

**Figure 12.** (a) Fluorescence optical microscopy (top view image) of a waveguide containing MEH-PPV fabricated by two-photon polymerization on mesoporous silica substrate. Light is guided through the microstructure ends when it is excited at its center. In (b) is displayed a schematic side view of the structure. Reprinted with permission from (Mendonca, et al.,2009).Copyright [2009], American Institute of Physics.

- *Incorporation of azoaromatic dyes*

Farsari et al (Farsari, et al.,2008) reported the fabrication of photonic crystals via two-photon absorption polymerization, by incorporating into the basic resin a nonlinear optically active chromophore, based on reacting Disperse Red 1 (DR1) with (3-isocyanopropyl) triethoxysilane. The structures reported by them had a bright red color, typical of Disperse Red 1 and presented stop-gaps at specific frequencies, close to the near infrared region, typical of photonic crystals.

Birefringence in microstructures have been explored by Mendonça et al (Mendonca, et al.,2007), where they have fabricated, via two-photon absorption polymerization, microstructures incorporating the azodye DR13, as the one displayed in the SEM image in Fig. 13 (a). Birefringence could be optically induced and erased in these microstructures due to a reversible trans-cis photoisomerization and a subsequent molecular orientation of the azo group. After exposure to laser, the microstructure exhibited residual birefringence because the chromophore molecules become oriented in the direction perpendicular to the laser polarization. Figure 13 (b) and (c) show the corresponding transmission microscopy images, where the microstructure is visible when the angle between the sample axis, defined by the Ar<sup>+</sup> ion laser exposure and the polarizers, is an odd multiple of 45°. This birefringence can be completely erased with circularly polarized light or by heating the sample close to the polymer glass transition temperature.

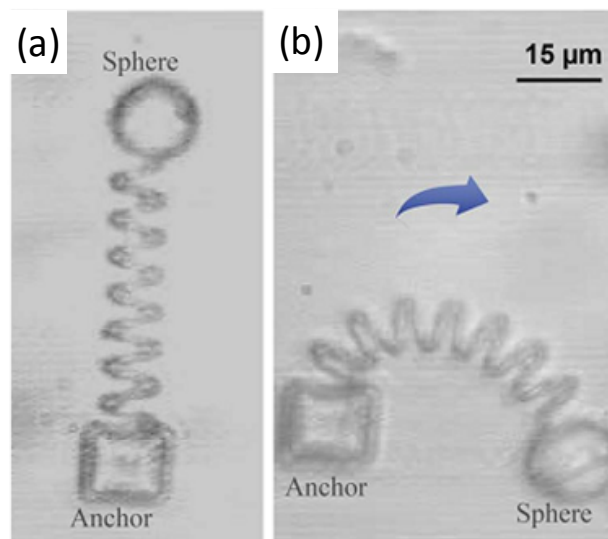

**Figure 13.** (a) Scanning electron micrograph of a cubic microstructure containing DR13. Polarization microscope images of a microstructure (like the one shown in (a)) at two angles between the polarizer and sample axis, displaying the birefringence behavior owing to DR13 incorporation. Reprinted with permission from (Mendonca, et al.,2007). Copyright [2007], American Institute of Physics.

- *Incorporation of magnetic nanoparticles*

Designing and fabricating microdevices by two-photon absorption polymerization that would be easily manipulated are important to understand the mechanics on the mi-

cro/nanomachine motion. Wang et al, (Wang, et al.,2009) proposed an interesting methodology where the basic resin was doped with surface-modified  $\text{Fe}_3\text{O}_4$  nanoparticles, and yielded structures with magnetic properties, whose movement could be externally controlled by magnets. Figure 14 displays a magnetic microspring fabricated by two-photon absorption polymerization, where one end of the spring remains attached to an anchor, which in turn, is attached to the substrate, and the other end is attached to a freely moving sphere. By applying a magnetic field, the object was moved in the direction of higher magnetic field strength. Therefore, by changing the ferromagnet position, distinct motions could be induced, as displayed in Fig. 14 (a) and (b), which shows the microspring in its non-alongated state (a) and in its alongated state (b).



**Figure 14.** Photograph of a magnetic micro-spring fabricated via two-photon absorption polymerization, by using a resin doped with magnetic nanoparticles. (a) Microspring in its natural non-alongated state and (b) in its alongated state. Reprinted with permission from (Wang, et al.,2009). Copyright [2009], Optical Society of America.

#### - *Incorporation of bio-related materials*

Two-photon polymerized structures incorporating biomaterials have also been subject of investigation by a few research groups. For instance, chitosan-containing microstructures fabricated by two-photon polymerization have been fabricated by Correa et al (Correa, et al.,2009). Chitosan is a biodegradable and biocompatible polymer, with applications in blood coagulation, soft tissue and bone regeneration, which could render to the microstructures appealing properties for medical applications. In that work, it was demonstrated, by Raman microscopy, that chitosan does not react chemically with the matrix resin, retaining its characteristics after the fabrication process, which is suitable for biomedical applications.

A methodology employing two-photon absorption polymerization to fabricate antibactericide microneedles was proposed by Gittard et al (Gittard, et al.,2010). Nowadays, the use of microneedles for drug delivery is still limited because of the risk of infection associated with contamination of the microneedles. Such problem may be overcome by imparting these devices

with antimicrobial properties. Gittard et al (Gittard, et al.,2010) used a photopolymerization-micromolding technique to fabricate microneedle arrays containing Polyethylene Glycol-Gentamicin Sulfate, which inhibited growth of *Staphylococcus aureus* bacteria.

Claeyssens et al (Claeyssens, et al.,2009) proposed using two-photon polymerization to fabricate microstructures by using the biodegradable triblock copolymer poly( $\epsilon$ -caprolactone-co-trimethylenecarbonate)-b-poly(ethyleneglycol)-b-poly( $\epsilon$ -caprolactone-co-trimethylenecarbonate). Samples of the structures fabricated are displayed in the SEM images in Fig. 15, which present good resolution. Besides, the initial cytotoxicity tests employed showed that the material does not affect cell proliferation, which demonstrates the capability of using two-photon polymerization to fabricate biodegradable scaffolds for tissue engineering.

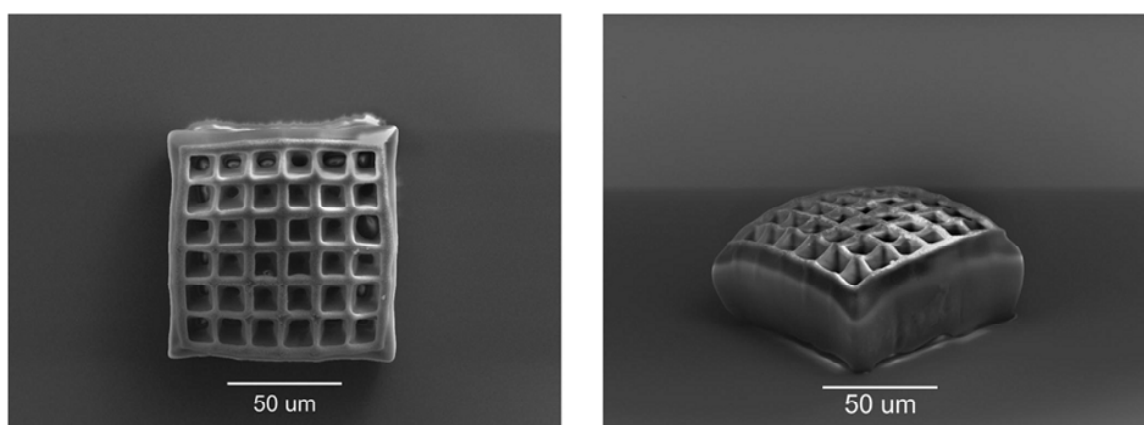

**Figure 15.** Scanning electron micrographs of structures fabricated with biodegradable triblock copolymer poly( $\epsilon$ -caprolactone-co-trimethylenecarbonate)-b-poly(ethyleneglycol)-b-poly( $\epsilon$ -caprolactone-co-trimethylenecarbonate). Reprinted with permission from (Claeyssens, et al.,2009). Copyright [2009], American Chemical Society.

Farsari et al (Drakakis, et al.,2006, Farsari, et al.,2010) have functionalized the surface of tridimensional structures made with a biocompatible organic-inorganic hybrid matrix, and subsequently immobilized photosensitive biotin on it. The integrity of biotin was confirmed by binding and detecting the presence and distribution of avidin via fluorescence microscopy. Experiments with peptides have also been carried out by the same group. Such methodology seems promising for applications in scaffolds for cell growth and tissue engineering.

- *Incorporation of other organic and inorganic materials*

Research groups have used a considerable variety of doping materials and methodologies for incorporating such materials into the base resins, in order to render, for instance, optical properties to the two-photon polymerized microstructures. Sun et al (Sun, et al.,2007) proposed a methodology to produce microstructures containing embedded CdS nanoparticles. The materials were prepared by using Cd acrylate derivatives as the base resin, and after the microfabrication process, the structures were treated with H<sub>2</sub>S gas for about 48 h to form CdS-polymer nanocomposites. By using this methodology, they were able to fabricate photonic crystals and structures presenting a high fluorescence signal.

Jia et al (Jia, et al.,2010) fabricated microstructures using a organic–inorganic hybrid photo-sensitive polymer containing dispersed PbS quantum dots. Such material exhibits high third-order nonlinearity, and was used to fabricate woodpile-shape photonic crystals with stop gaps in the telecommunication wavelength region. The authors also prospected these nanocomposite materials for applications in active micro/nanodevices, such as ultrafast switching, signal regeneration, and high speed demultiplexing systems.

Shukla et al (Shukla, et al.,2010) demonstrated a new method for producing subwavelength plasmonic and conductive patterned structures within a polymeric host. The method involves both, two-photon-initiated photoreduction of a gold precursor and two-photon polymerization using a negative photoresist. By this methodology, they several types of structures, including optically active planar chiral structures and plasmonic nanostructures, which have potential use for the development of metamaterials. Example of such structures are displayed in Fig. 16 (a) and (b) (Shukla, et al.,2010), which shows confocal microscopy plasmonic donuts fabricated by the mentioned method.

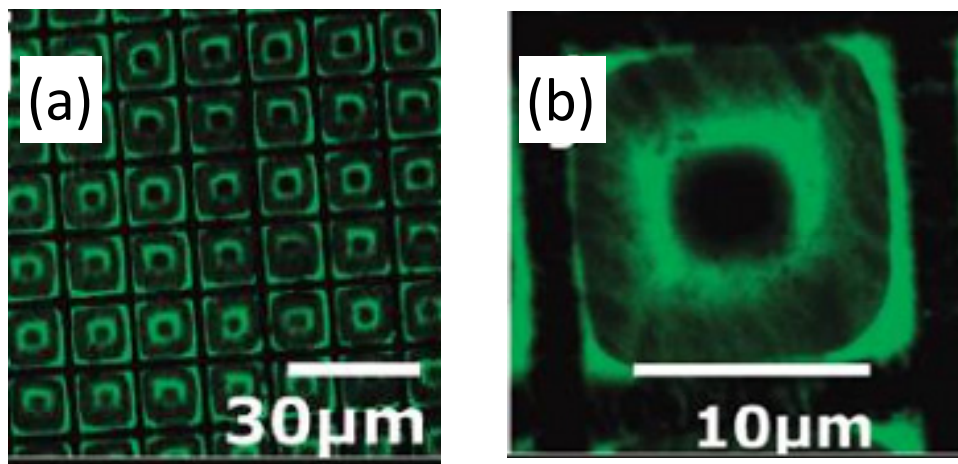

**Figure 16.** (a,b). Confocal fluorescence image of plasmonic donuts structures fabricated by a combination of two-photon-initiated photoreduction of a gold precursor and two-photon absorption polymerization. Reprinted with permission from (Shukla, et al.,2010). Copyright [2010], American Chemical Society.

Microstructures containing rodhamine have been fabricated by two-photon absorption polymerization by a few research groups (Correa, et al.,2011, Zukauskas, et al.,2010). Rhodamine is a remarkable material to dope resins owing to its chemical stability, strong luminescence and nonlinear optical properties. Correa et al. (Correa, et al.,2011) fabricated two-photon polymerized structures containing rodhamine and excited them with silica wires with diameters of approximately 1  $\mu\text{m}$ , which are produced through the fiber tapering technique (flame-heated fiber drawing) (Tong, et al.,2003). Figure 17 (a) shows a schematic view of the excitation of a two-photon polymerized microstructure with silica tapered fiber. Figure 17 (b) and (c) show optical micrographs of (a) frontal and (b) lateral excitation at 514 nm of microstructures containing rhodamine by tapered silica fibers (Correa, et al.,2011, Correa, et al.,2012).



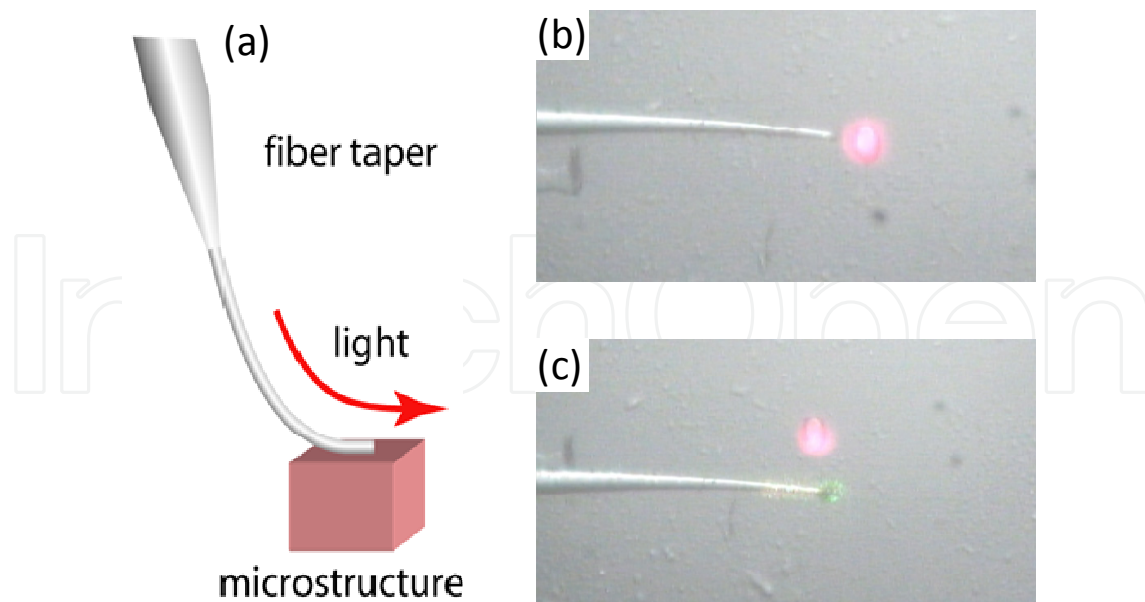

**Figure 17.** Excitation at 514 nm of a two-photon polymerized microstructure doped with rhodamine using silica tapered fiber. (a) Schematic view, (b) frontal excitation and (c) lateral excitation. (b) and (c) reprinted with permission from (Correa, et al.,2011). Copyright [2011], Springer Science+Business Media B.V.

To further advance the use of the structures' optical properties, integration between them was explored, aiming at exciting or collecting light by using silica tapered fibers. The integration between structures was carried out with silica tapered fibers similar to the one displayed in Fig. 17. Figure 18 shows a set of two-photon polymerized structures connect by such tapered optical fibers. This step represents a potential approach to integrate arrays of optical microstructures, aiming at the fabrication of micro-optical photonics circuitry.

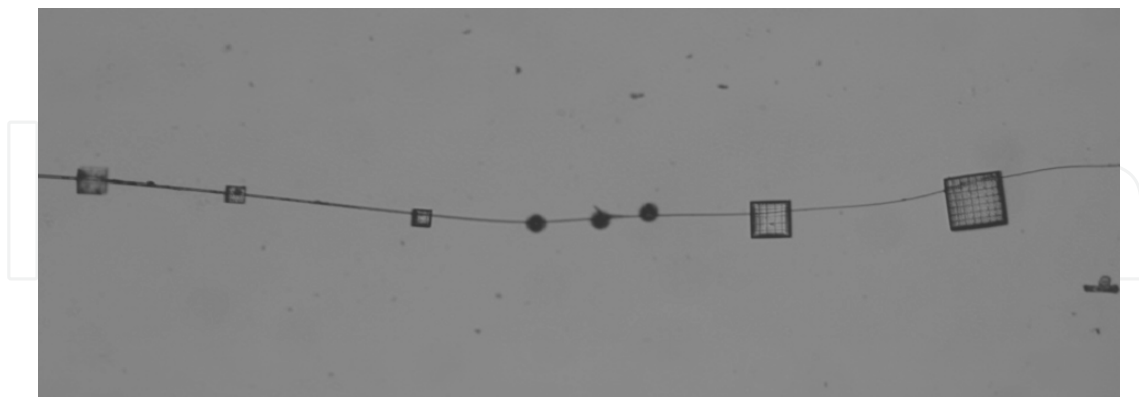
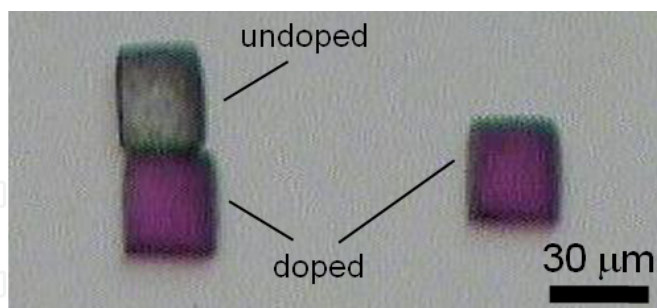

**Figure 18.** Transmission optical micrograph of a set of two-photon polymerized structures connected by tapered optical fibers.

By incorporating two or more distinct dopants into the base resin, one can obtain two-photon polymerized microstructures that present, for instance, fluorescence at two or more distinct wavelengths. This approach would be useful, for instance, to produce multi-colored pixels presenting a RGB pattern. In Fig. 19, we show microscope images of undoped (gray)



and rhodamine doped (purple) microstructures fabricated by two-photon polymerization in the same substrate.



**Figure 19.** Optical microcopy image of two-photon polymerized structures fabricated on the same substrate. The gray structure was fabricated only with the base resin (undoped), while the purple one (doped) contains rhodamine.

In addition to the based on the methodology of incorporating materials into the bulk of basic resin, another interesting approach is to functionalize the fabricated microstructure's surface. In this case, after functionalization, other materials can be adhered to the surface, giving to the microstructures unique properties. For instance, functionalization has been carried out by several groups to achieve metallization of structures' surface, with gold, silver, and copper (Farrer, et al.,2006, Rill, et al.,2008, Takeyasu, et al.,2008). Such metallic structures can be highly conductive, opening doors for applications in microelectrical circuitry.

## 6. Conclusions

This chapter aimed at demonstrating fundamental and experimental aspects of fabrication of doped microstructures via two-photon absorption polymerization. Due to the efforts of many research groups in the last years, the use of this technique and its applications has spread out all over the world. By using this technique, tridimensional microstructures of complex shape, high definition and structural integrity can be fabricated to be used in microdevices. Distinct dopants incorporated into the basic resin formulation can yield to the microstructure features such as biocompatibility, luminescence, magnetic properties and waveguiding. Such microstructures with enhanced properties are highly desired for applications in optical devices, photonic crystals, micro-waveguides, microfluidics and scaffolds for tissue engineering, whose commercial applications in the market are expected to happen in the next years.

## Author details

Daniel S. Correa

*Embrapa Instrumentação, São Carlos, SP, Brazil*

Leonardo De Boni, Adriano J. G. Otuka, Vinicius Tribuzi and Cleber R. Mendonça

*Instituto de Física de São Carlos, Universidade de São Paulo, São Carlos, SP, Brazil*

## Acknowledgement

We thank financial support from Fundação de Amparo à Pesquisa do Estado de São Paulo (FAPESP), Conselho Nacional de Desenvolvimento Científico Tecnológico (CNPq), and Embrapa.

## 7. References

- Abella, I. D. (1962). Optical double-photon absorption in cesium vapor. *Physical Review Letters*, vol. 9, 453-&
- Baldacchini, T., LaFratta, C. N., Farrer, R. A., Teich, M. C., Saleh, B. E. A., Naughton, M. J., and Fourkas, J. T. (2004). Acrylic-based resin with favorable properties for three-dimensional two-photon polymerization. *Journal of Applied Physics*, vol. 95, 6072-6076
- Balu, M., Hales, J., Hagan, D. J., and Van Stryland, E. W. (2004). White-light continuum Z-scan technique for nonlinear materials characterization. *Optics Express*, vol. 12, 3820-3826
- Boyd, R. W., *Nonlinear optics*. Boston: Academic Press, 1992.
- Chung, S.-J., Maciel, G. S., Pudavar, H. E., Lin, T.-C., He, G. S., Swiatkiewicz, J., Prasad, P. N., Lee, D. W., Lin, J.-I., and Menard, M. (2002). Two-photon properties and excitation dynamics of poly(p-phenylenevinylene) derivatives carrying phenylanthracene and branched alkoxy pendants. *J. Phys. Chem. A*, vol. 106, 7512-7520
- Claeysens, F., Hasan, E. A., Gaidukeviciute, A., Achilleos, D. S., Ranella, A., Reinhardt, C., Ovsianikov, A., Xiao, S., Fotakis, C., Vamvakaki, M., Chichkov, B. N., and Farsari, M. (2009). Three-Dimensional Biodegradable Structures Fabricated by Two-Photon Polymerization. *Langmuir*, vol. 25, 3219-3223
- Correa, D., S, Tribuzi, V., Cardoso, M. R., Misoguti, L., and Mendonca, C. R. (2011). Selective excitation through tapered silica fibers of fluorescent two-photon polymerized structures. *Applied Physics A-Materials Science & Processing*, vol. 102, 435-439
- Correa, D. S., Cardoso, M. R., Tribuzi, V., Misoguti, L., and Mendonca, C. R. (2012). Femtosecond Laser in Polymeric Materials: Microfabrication of Doped Structures and Micromachining. *IEEE Journal of Selected Topics in Quantum Electronics*, vol.18, 176-186
- Correa, D. S., De Boni, L., Balogh, D. T., and Mendonca, C. R. (2007). Three- and four-photon excitation of poly(2-methoxy-5-(2'-ethylhexyloxy)-1,4-phenylenevinylene) (MEH-PPV). *Advanced Materials*, vol. 19, 2653-2656
- Correa, D. S., Tayalia, P., Cosendey, G., Dos Santos Jr., D. S., Aroca, R. F., Mazur, E., and Mendonca, C. R. (2009). Two-photon polymerization for fabricating structures containing the biopolymer chitosan. *Journal of Nanoscience and Nanotechnology*, vol. 9, 5845-5849
- Cumpston, B. H., Ananthavel, S. P., Barlow, S., Dyer, D. L., Ehrlich, J. E., Erskine, L. L., Heikal, A. A., Kuebler, S. M., Lee, I. Y. S., McCord-Maughon, D., Qin, J. Q., Rockel, H., Rumi, M., Wu, X. L., Marder, S. R., and Perry, J. W. (1999). Two-photon polymerization initiators for three-dimensional optical data storage and microfabrication. *Nature*, vol. 398, 51-54

- De Boni, L., Andrade, A. A., Correa, D. S., Balogh, D. T., Zilio, S. C., Misoguti, L., and Mendonca, C. R. (2004). Nonlinear absorption spectrum in MEH-PPV/chloroform solution: A competition between two-photon and saturated absorption processes. *Journal of Physical Chemistry B*, vol. 108, 5221-5224
- De Boni, L., Andrade, A. A., Misoguti, L., Mendonca, C. R., and Zilio, S. C. (2004). Z-scan measurements using femtosecond continuum generation. *Optics Express*, vol. 12, 3921-3927
- Drakakis, T. S., Papadakis, G., Sambani, K., Filippidis, G., Georgiou, S., Gizeli, E., Fotakis, C., and Farsari, M. (2006). Construction of three-dimensional biomolecule structures employing femtosecond lasers. *Applied Physics Letters*, vol. 89, 144108
- Farrer, R. A., LaFratta, C. N., Li, L. J., Praino, J., Naughton, M. J., Saleh, B. E. A., Teich, M. C., and Fourkas, J. T. (2006). Selective functionalization of 3-D polymer microstructures. *Journal of the American Chemical Society*, vol. 128, 1796-1797
- Farsari, M., Ovsianikov, A., Vamvakaki, M., Sakellari, I., Gray, D., Chichkov, B. N., and Fotakis, C. (2008). Fabrication of three-dimensional photonic crystal structures containing an active nonlinear optical chromophore. *Applied Physics a-Materials Science & Processing*, vol. 93, 11-15
- Farsari, M., Vamvakaki, M., and Chichkov, B. N. (2010). Multiphoton polymerization of hybrid materials. *Journal of Optics*, vol. 12, 124001
- Fowles, G. R., Introduction to Modern Optics, 2nd ed. New York: Dover Publications, 1989.
- Gittard, S. D., Ovsianikov, A., Akar, H., Chichkov, B., Monteiro-Riviere, N. A., Stafslie, S., Chisholm, B., Shin, C. C., Shih, C. M., Lin, S. J., Su, Y. Y., and Narayan, R. J. (2010). Two Photon Polymerization-Micromolding of Polyethylene Glycol-Gentamicin Sulfate Microneedles. *Advanced Engineering Materials*, vol. 12, B77-B82
- Göppert-Mayer, M. (1931). Elementary processes with two quantum jumps. *Ann. Phys.*, vol. 9, 273-294
- Haske, W., Chen, V. W., Hales, J. M., Dong, W. T., Barlow, S., Marder, S. R., and Perry, J. W. (2007). 65 nm feature sizes using visible wavelength 3-D multiphoton lithography. *Optics Express*, vol. 15, 3426-3436
- Jia, B. H., Buso, D., van Embden, J., Li, J. F., and Gu, M. (2010). Highly Non-Linear Quantum Dot Doped Nanocomposites for Functional Three-Dimensional Structures Generated by Two-Photon Polymerization. *Advanced Materials*, vol. 22, 2463-2467
- Juodkasis, S., Mizeikis, V., Seet, K. K., Miwa, M., and Misawa, H. (2005). Two-photon lithography of nanorods in SU-8 photoresist. *Nanotechnology*, vol. 16, 846-849
- Kaiser, W. and Garrett, C. G. B. (1961). 2-Photon Excitation in CaF<sub>2</sub> - Eu<sup>2+</sup>. *Physical Review Letters*, vol. 7, 229-231
- Kawata, S., Sun, H. B., Tanaka, T., and Takada, K. (2001). Finer features for functional microdevices - Micromachines can be created with higher resolution using two-photon absorption. *Nature*, vol. 412, 697-698
- Konjhdzic, D., Bretinger, H., Wilczok, U., Dreier, A., Ladenburger, A., Schmidt, M., Eich, M., and Marlow, F. (2005). Low-n mesoporous silica films: structure and properties. *Applied Physics a-Materials Science & Processing*, vol. 81, 425-432

- LaFratta, C. N., Fourkas, J. T., Baldacchini, T., and Farrer, R. A. (2007). Multiphoton fabrication. *Angewandte Chemie-International Edition*, vol. 46, 6238-6258
- Lee, K. S., Kim, R. H., Yang, D. Y., and Park, S. H. (2008). Advances in 3D nano/microfabrication using two-photon initiated polymerization. *Progress in Polymer Science*, vol. 33, 631-681
- Liska, R., Schuster, M., Infuhr, R., Tureek, C., Fritscher, C., Seidl, B., Schmidt, V., Kuna, L., Haase, A., Varga, F., Lichtenegger, H., and Stampfl, J. (2007). Photopolymers for rapid prototyping. *Journal of Coatings Technology and Research*, vol. 4, 505-510
- Marder, S. R., Bredas, J. L., and Perry, J. W. (2007). Materials for multiphoton 3D microfabrication. *MRS Bulletin*, vol. 32, 561-565
- Maruo, S., Nakamura, O., and Kawata, S. (1997). Three-dimensional microfabrication with two-photon-absorbed photopolymerization. *Optics Letters*, vol. 22, 132-134
- Mendonca, C. R., Baldacchini, T., Tayalia, P., and Mazur, E. (2007). Reversible birefringence in microstructures fabricated by two-photon absorption polymerization. *Journal of Applied Physics*, vol. 102, 013109
- Mendonca, C. R., Correa, D. S., Baldacchini, T., Tayalia, P., and Mazur, E. (2008). Two-photon absorption spectrum of the photoinitiator Lucirin TPO-L. *Applied Physics A-Materials Science & Processing*, vol. 90, 633-636
- Mendonca, C. R., Correa, D. S., Marlow, F., Voss, T., Tayalia, P., and Mazur, E. (2009). Three-dimensional fabrication of optically-active microstructures containing MEH-PPV. *Applied Physics Letters*, vol. 95, 113309
- Nguyen, T. Q., Martini, I. B., Liu, J., and Schwartz, B. J. (2000). Controlling interchain interactions in conjugated polymers: The effects of chain morphology on exciton-exciton annihilation and aggregation in MEH-PPV films. *Journal of Physical Chemistry B*, vol. 104, 237-255
- Oliveira, S. L., Correa, D. S., De Boni, L., Misoguti, L., Zilio, S. C., and Mendonca, C. R. (2006). Two-photon absorption cross-section spectrum of a pi-conjugated polymer obtained using the white-light continuum Z-scan technique. *Applied Physics Letters*, vol. 88, 021911
- Ovsianikov, A., Chichkov, B., Adunka, O., Pillsbury, H., Doraiswamy, A., and Narayan, R. J. (2007). Rapid prototyping of ossicular replacement prostheses. *Applied Surface Science*, vol. 253, 6603-6607
- Parker, I. D. (1994). Carrier tunneling and device characteristics in polymer light-emitting-diodes. *Journal of Applied Physics*, vol. 75, 1656-1666
- Rill, M. S. R. M. S., Plet, C., Thiel, M., Staude, I., Von Freymann, G., Linden, S., and Wegener, M. (2008). Photonic metamaterials by direct laser writing and silver chemical vapour deposition. *Nature Materials*, vol. 7, 543-546
- Schlie, S., Ngezahayo, A., Ovsianikov, A., Fabian, T., Kolb, H. A., Haferkamp, H., and Chichkov, B. N. (2007). Three-dimensional cell growth on structures fabricated from ORMOCER (R) by two-photon polymerization technique. *Journal of Biomaterials Applications*, vol. 22, 275-287

- Serbin, J., Ovsianikov, A., and Chichkov, B. (2004). Fabrication of woodpile structures by two-photon polymerization and investigation of their optical properties. *Optics Express*, vol. 12, 5221-5228
- Sheik-Bahae, M., A. A. Said, T. H. Wei, D. J. Hagan, E. W. Van Stryland. (1990). Sensitive Measurement of Optical Nonlinearities Using a Single Beam. *Ieee Journal of Quantum Electronics*, vol. 26, 760-769
- Shen, Y. R., *The Principles of Nonlinear Optics*. New York: John Wiley, 1984.
- Shukla, S., Vidal, X., Furlani, E. P., Swihart, M. T., Kim, K. T., Yoon, Y. K., Urbas, A., and Prasad, P. N. (2010). Subwavelength Direct Laser Patterning of Conductive Gold Nanostructures by Simultaneous Photopolymerization and Photoreduction. *Acs Nano*, vol. 5, 1947-1957
- Sun, H. B. and Kawata, S., "Two-photon photopolymerization and 3D lithographic microfabrication," in *NMR - 3D Analysis - Photopolymerization*. vol. 170 Berlin: Springer-Verlag Berlin, 2004, pp. 169-273.
- Sun, H. B., Tanaka, T., Takada, K., and Kawata, S. (2001). Two-photon photopolymerization and diagnosis of three-dimensional microstructures containing fluorescent dyes. *Applied Physics Letters*, vol. 79, 1411-1413
- Sun, Z. B., Dong, X. Z., Nakanishi, S., Chen, W. Q., Duan, X. M., and Kawata, S. (2007). Log-pile photonic crystal of CdS-polymer nanocomposites fabricated by combination of two-photon polymerization and in situ synthesis. *Applied Physics a-Materials Science & Processing*, vol. 86, 427-431
- Takeyasu, N., Tanaka, T., and Kawata, S. (2008). Fabrication of 3D metal/polymer microstructures by site-selective metal coating. *Applied Physics a-Materials Science & Processing*, vol. 90, 205-209
- Tayalia, P., Mendonca, C. R., Baldacchini, T., Mooney, D. J., and Mazur, E. (2008). 3D cell-migration studies using two-photon engineered polymer scaffolds. *Advanced Materials*, vol. 20, 4494-4498
- Tong, L. M., Gattass, R. R., Ashcom, J. B., He, S. L., Lou, J. Y., Shen, M. Y., Maxwell, I., and Mazur, E. (2003). Subwavelength-diameter silica wires for low-loss optical wave guiding. *Nature*, vol. 426, 816-819
- Wang, J., Xia, H., Xu, B. B., Niu, L. G., Wu, D., Chen, Q. D., and Sun, H. B. (2009). Remote manipulation of micronanomachines containing magnetic nanoparticles. *Optics Letters*, vol. 34, 581-583
- Yu, G., Gao, J., Hummelen, J. C., Wudl, F., and Heeger, A. J. (1995). Polymer photovoltaic cells - enhanced efficiencies via a network of internal donor-acceptor heterojunctions. *Science*, vol. 270, 1789-1791
- Zukauskas, A., Malinauskas, M., Kontenis, L., Purlys, V., Paipulas, D., Vengris, M., and Gadonas, R. (2010). Organic dye doped microstructures for optically active functional devices fabricated via two-photon polymerization technique. *Lithuanian Journal of Physics*, vol. 50, 55-61