

We are IntechOpen, the world's leading publisher of Open Access books Built by scientists, for scientists

4,800

Open access books available

122,000

International authors and editors

135M

Downloads

Our authors are among the

154

Countries delivered to

TOP 1%

most cited scientists

12.2%

Contributors from top 500 universities



WEB OF SCIENCE™

Selection of our books indexed in the Book Citation Index
in Web of Science™ Core Collection (BKCI)

Interested in publishing with us?
Contact book.department@intechopen.com

Numbers displayed above are based on latest data collected.
For more information visit www.intechopen.com



Acoustic Emission of Composite Vessel

Hyun-Sup Jee and Jong-O Lee

Additional information is available at the end of the chapter

<http://dx.doi.org/10.5772/47877>

1. Introduction

There are about 10 million vehicles run on natural gas in the world. There are about 1.7 million low-pressure LPG vehicles [1], and 17,000 high-pressure CNG vehicles running in Korea and the number is increasing.[2]

Generally for CNG vehicles, type II vessel, where the increase in used pressure and lighter weight are achieved through fiber-reinforced composite material, which is wrapped in hoop-direction on the steel liner is used. Since 1984, the U.S. experienced more than 80 cases of vehicle fuel tank-related accidents [3] and Korea also experienced 8 cases in which the CNG tank exploded; thus, there is a need for the development of inspection technology for high-pressure fuel tanks. In the case of the U.S., the inspection technology of high-pressure fuel tanks were developed by DOD and NASA as an inspection technology for missile fuel tanks[4] but as the use of high-pressure fuel tanks for transport increased DOT executed a research on inspection technology for vehicles based on the research results of NASA and reported that among several NDT technology, Acoustic Emission(AE) has a possibility of being used as an inspection technology for vehicles[5,6]. The gas vessel, which is made of fiber-reinforced composite material, is unlike vessel made of only steel materials in that when the damage increases the acoustic generation activity increases but when the degree of damage increases even more, the acoustic generation activity rather decreases [7]. A study of defect detection and failure analysis for composite Materials using acoustic emission is progressing steadily [9-11,14].

2. Experiment

2.1. Experimental vessel

Experiment vessel used in this research is a 64 Liter CNG fuel tank used in vehicles. The thickness of the liner in the shell is about 6 mm and was made using the DDI (Deep Drawing Ironing) method[12,13] using 34CrMo4 steel plate, and is a type-II vessel in which glass fiber is hoop-wrapped on the shell of the liner.

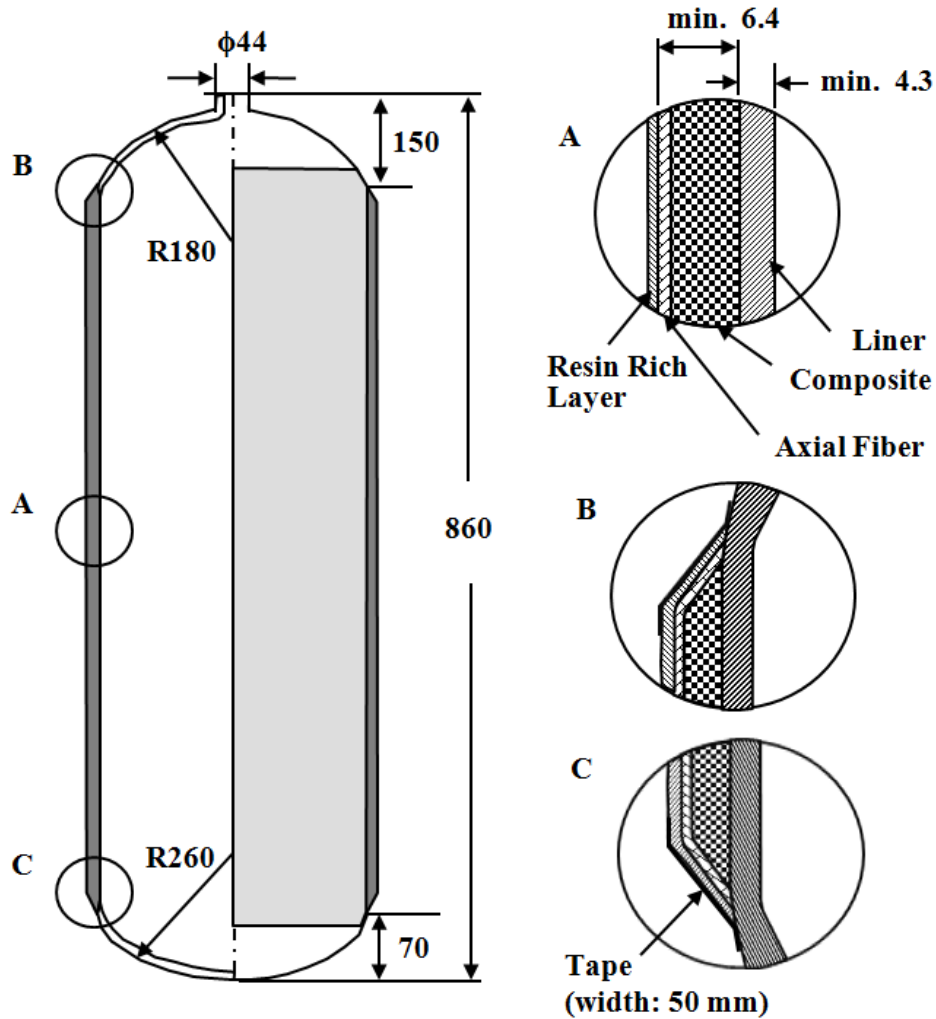

Figure 1. Schematic diagram of experimental vessel

	C	Mn	Si	P	S	Cr	Mo
Max	0.38	1.00	0.40	0.015	0.010	1.20	0.40
Min	0.25	0.40	0.10	-	-	0.80	0.15
P+S	≤0.020						

Table 1. Chemical composition of vessel liner (unit : wt.%)

2.2. Method of experiment

For the test, the acoustic emission sensor is R15I (PAC) with the resonance frequency of 150 kHz and cable of RG58A/U (10m) is put on the middle of shell using the vacuum grease.

The detected AE signal is put into the DiSP-52 Acoustic emission workstation (PAC) for processing. In addition, the water was used as medium for burst test. The threshold value of test was set at 45dB. The source of simulated sound was the destruction of the 2H Pentel pencil lead. The average sensitivity of sensor was 98dB within 1 inch from sensor.

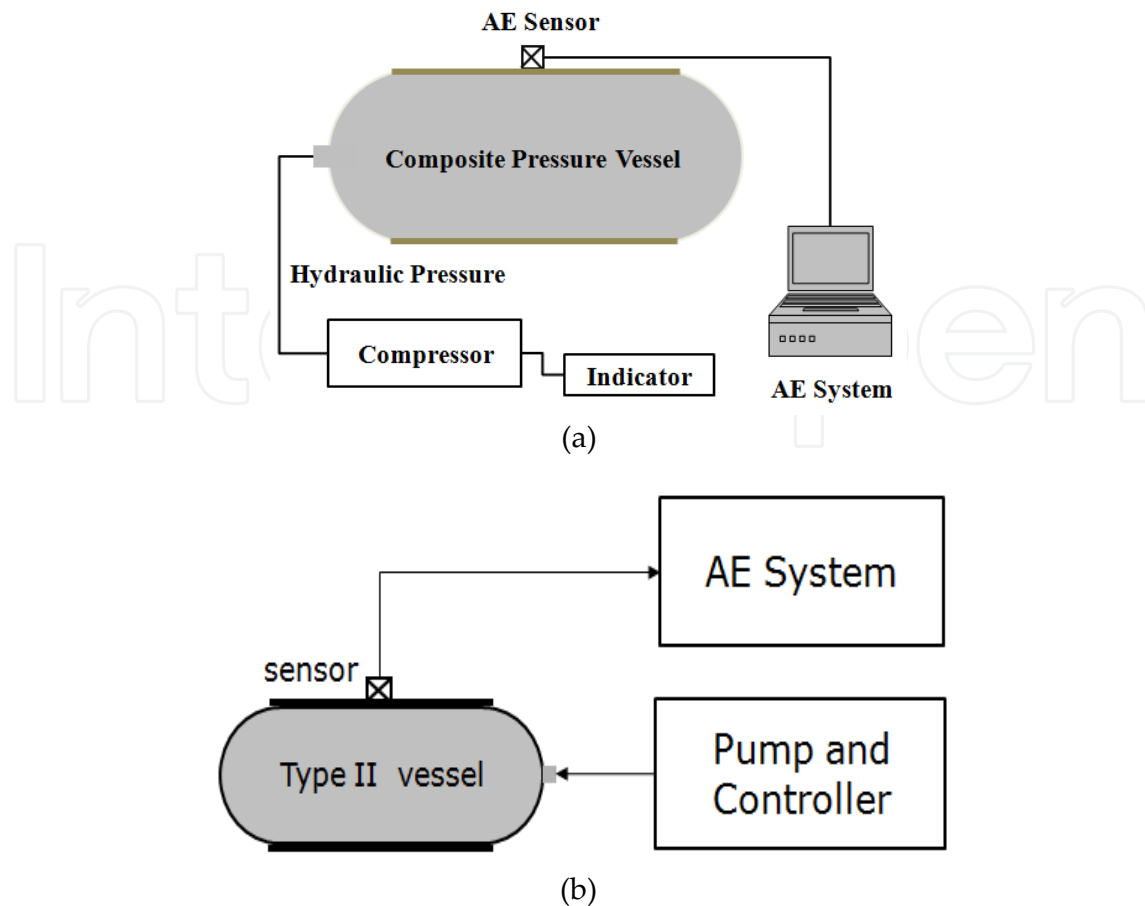

Figure 2. Diagram of Experimentation : (a) Burst and (b) fatigue test of the composite vessel

The burst pressure was estimated to be 600 bar under the pressured conditions. By raising the pressure to 30%, 50%, 60%, 70%, 80% and 90% of estimated burst pressure and keeping each pressure stage for 10 minutes as in Figure 3(a), we acquired the AE signal from each stage. As can be seen in the figure, pressure was put on the vessel with a pump to control the pressure and acoustic emission signals were detected using acoustic emission sensors attached to the vessel. And the signal were processed and analyzed after fed into AE equipment. The fatigue test repeated 20000 cycles between 0 and 207 bar, afterwards which has a used pressure of 0 and afterwards, the pressure was continuously increased and the burst test was carried out. Figure 3(b) shows the conditions for pressurization.

3. Result and research

3.1. Burst test

3.1.1. Damage mechanism of composite vessel

First, the composite materials wrapped in the metal liner were separated due to the matrix crack and then each layer was separated from each other. Then, some section of the fuel tank was weakened due to the cutting of some reinforced fiber, causing the destruction of metal liner of that part and finally destroying the vessel.

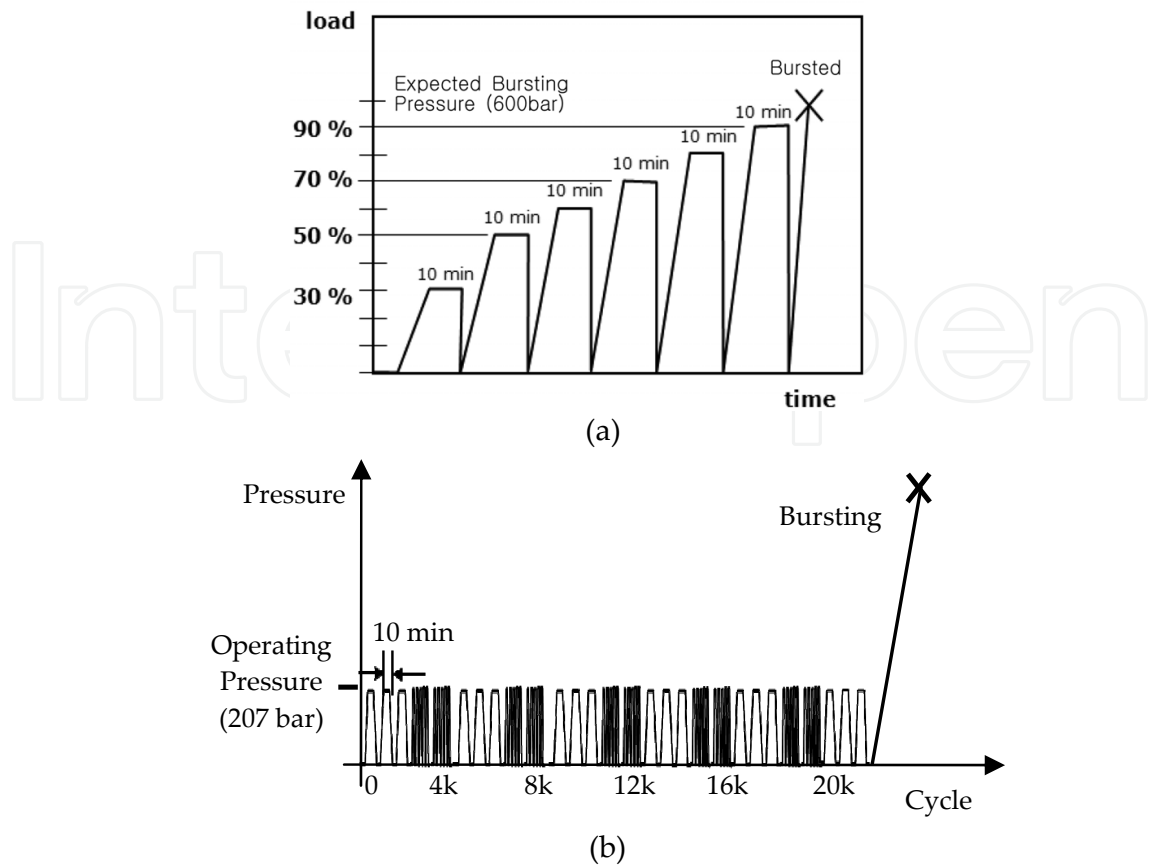

Figure 3. Loading sequence : (a) Burst and (b) fatigue test

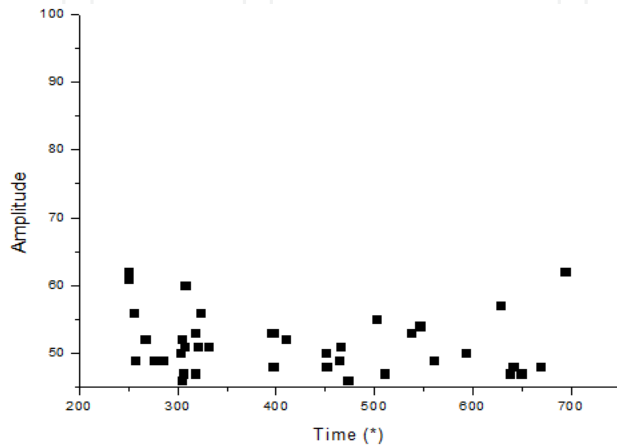

Figure 4. Composite vessel after burst test

3.1.2. AE signal generated during burst test

In this test, considering the flow noise during the initial pressure, I excluded the signal during the first two minutes from the data but included the remaining 8 minutes data for evaluation. Generally, for the evaluation of the soundness of vessel, a tester imposes

pressure on the vessel and keeps the pressure for some time until some sound emits from it. This is called the analysis of creep effect. The values in Figure 5 show that the pressure up to 360 bar, or 60% of the expected burst press is weak, showing that the vessel is not likely to receive significant damages. But after 70% of the expected pressure, the signals of 60dB or more are often shown, which may mean that there is a lot of creep effect and that the significant damages have been done to the vessel.



(a)

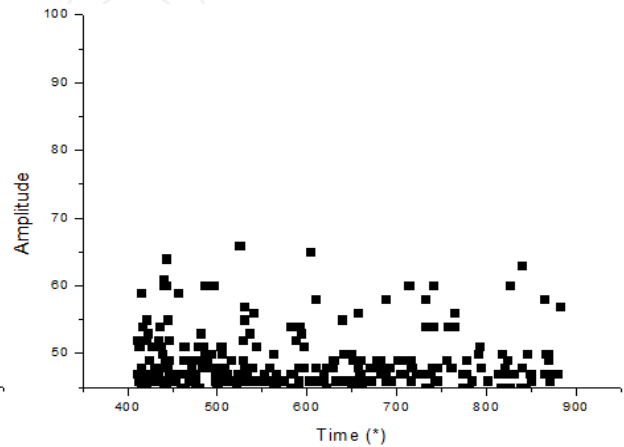

(b)

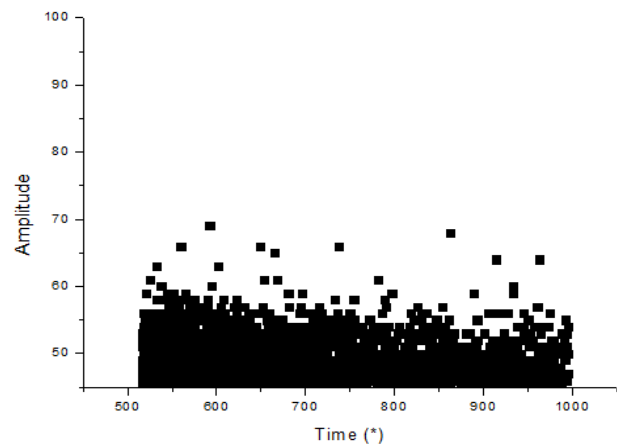

(c)

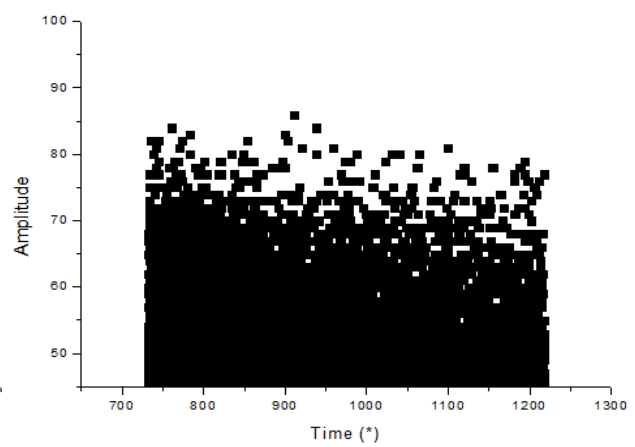

(d)

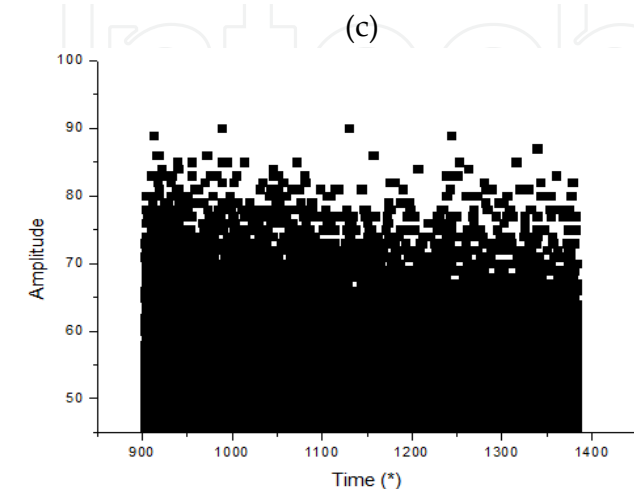

(e)

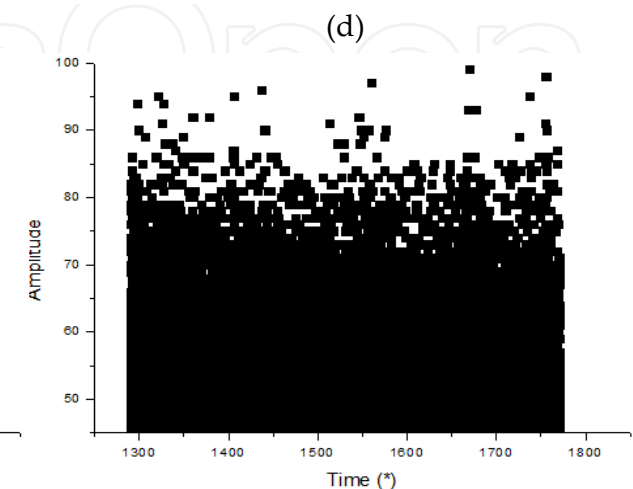

(f)

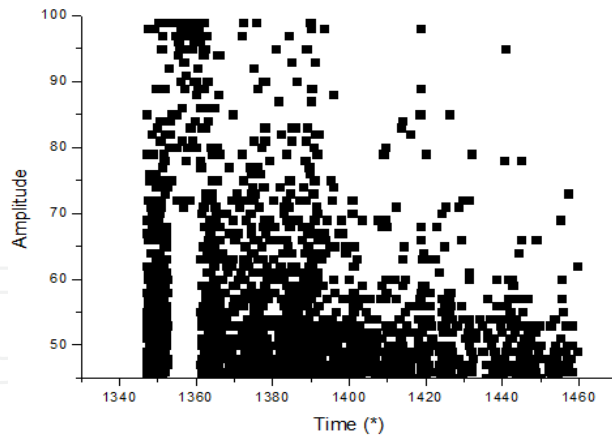

(g)

Figure 5. Amplitude vs Time plot during load holding : (a)30% (b)50% (c)60% (d)70% (e)80% (f)90% and (g)fractured

The pressure rise to the 80 % and 90 % of the expected burst pressure shows a lot of signals with high amplitudes. At the pressure stage of 540 bar or higher, where the burst is likely to occur, the signals with the amplitude of 80-100 dB continue to occur while giving the continuous leak signal from 1352 seconds to 1361 seconds. The burst occurred when the pressure rapidly went down to 400 bar. Figure 6 shows the total hits from 2 minutes after the start of each load. There is a rapid increase in the number of hits when the load pressure goes over 70 % of the expected burst pressure where the significant damage is likely to happen. In the final destruction, the number of total hits is low because the time to destruction was short, considering the felicity ratio and the pressure rising up to the fracture.

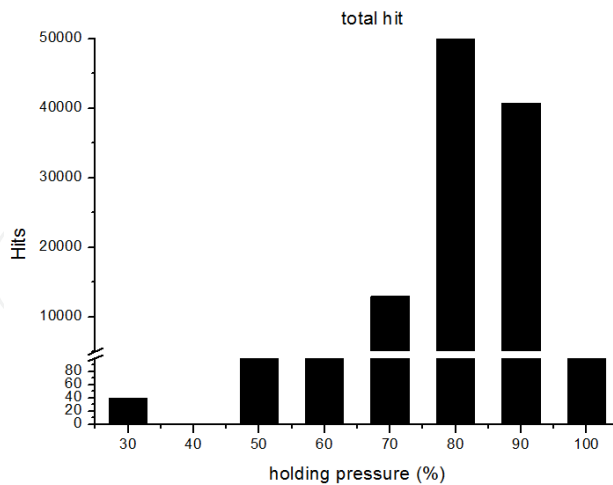

Figure 6. Total hits during load holding

Figure 7 and 8 show that the average rise time and duration for the signals occurred during the holding time of each load. The rise time and duration become shorter up to loads up to 70 % while those from time of 80 % to the time of burst get longer, during which the damage is likely to be greater.

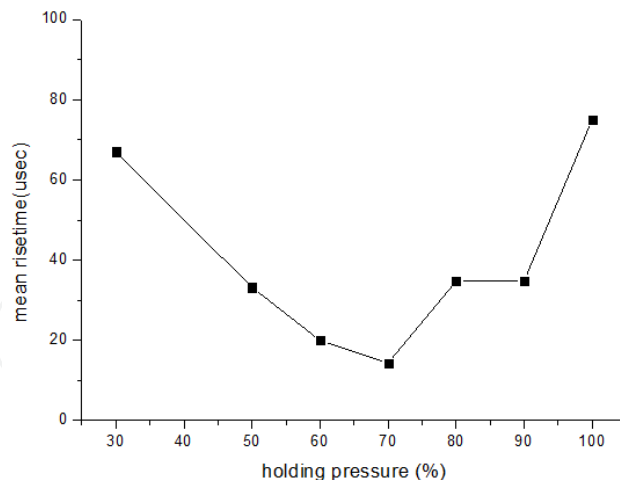

Figure 7. Mean rise time during load holding

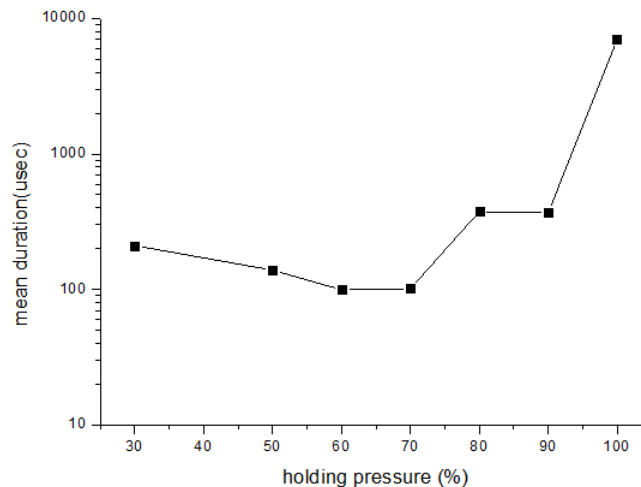

Figure 8. Mean duration during load holding

Unlike the metal vessel, the pressure vessel that is made with composite materials has various damage mechanisms including the matrix crack, crack growth, separation between layers, cutting of fiber, and destruction of metal liner. Figure 9 shows that at the load of 30 % stage, the amplitude of signal rises due to the increased sound emission from matrix crack of composite materials. It also shows that at the load of 50-60 % of the estimated burst pressure, the sound emission is weakened and thus the amplitude of the signal is also reduced. At the load of 70 % pressure, the interlayer separation and the cut of reinforced fiber start and the amplitude of the signal increases again. Then, more reinforcement fibers become severed and the metal liner begins to burst, showing a little increase in amplitude.

As shown below, the composite material pressure vessel has many damage mechanisms in it. The initial damage mechanism contains the matrix crack due to the stress as well as the crack grown. As shown in Figure 10 (a), the rise time appears at the range of 10 μ s and 100 μ s. This shows the creation of matrix crack and the growth of this crack. The signal from around 10 μ s is related to the creation of cracks while the signals from 100 μ s look to be related to the growth of the cracks.

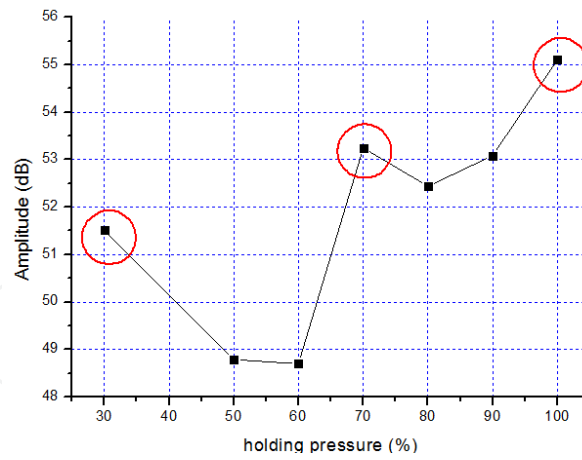
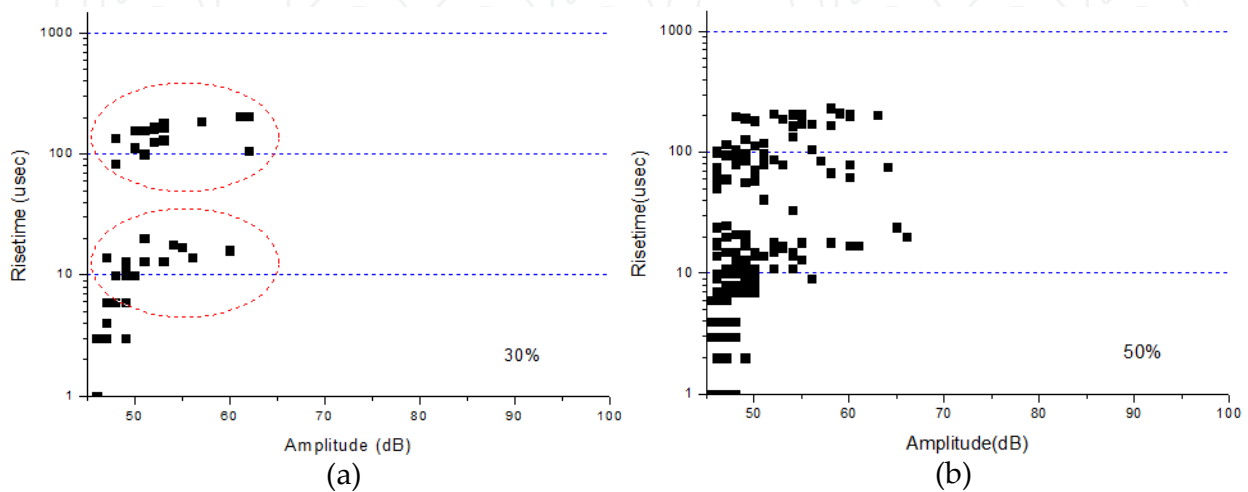

Figure 9. Mean amplitude during load holding

AE signals at the load of 50% and 60% show that the matrix crack and growth occur in this range instead of the additional causes for damages. At the load of 70%, a lot of the rise time of AE signals come from 500 μ s appear. It is likely to indicate that the new damage elements such as cut of reinforcement fiber appear. The rapid increase in AE signals around 10 μ s shows that the growth of matrix cracks such as growth of existing cracks and interlayer separation occur at a fast pace. Then, at the load of 80~90%, it is estimated that rapid damages such as growth of the previous matrix cracks and the cutting of reinforcement fiber occur, making much sound from cutting of reinforcement fiber. The 800 μ s of rise time at this stage is likely to be caused by the cutting of several lines of reinforcement fibers. Then, at 100% load, a composite of damage mechanisms occur, increasing the damage of vessel and then destroying the last metal liner.

Figure 11 shows the total count of sound emission signals which occur during the 2 minutes of holding time. These variables are better indications than mean rise time in Figure 7, mean duration of Figure 8 or mean amplitude of Figure 9. It was discovered that it was difficult to assess the damage against the vessel with variables such as mean amplitude, total hit, mean rise time, or mean duration but the total count and the total signal strength of the sound emitted when the load is pressed on, activation and vessel's damage were better indications for damages on the vessel.



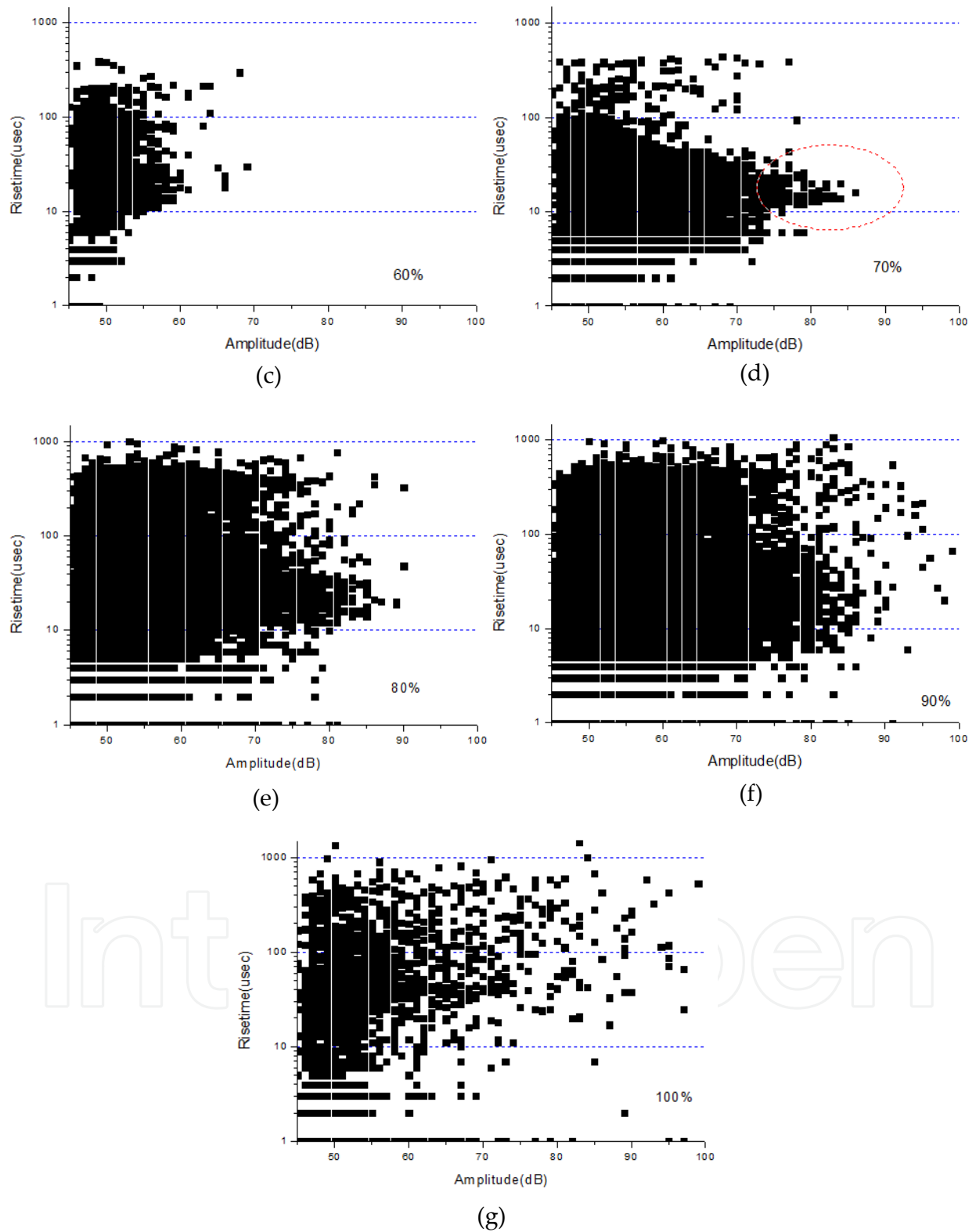

Figure 10. Rise time vs amplitude plot during load holding : (a)30% (b)50% (c)60% (d)70% (e)80% (f)90% and (g)fractured

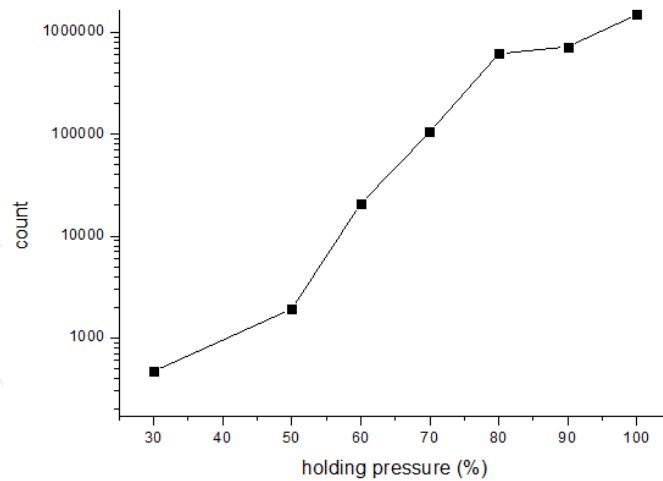

Figure 11. Total count during load holding

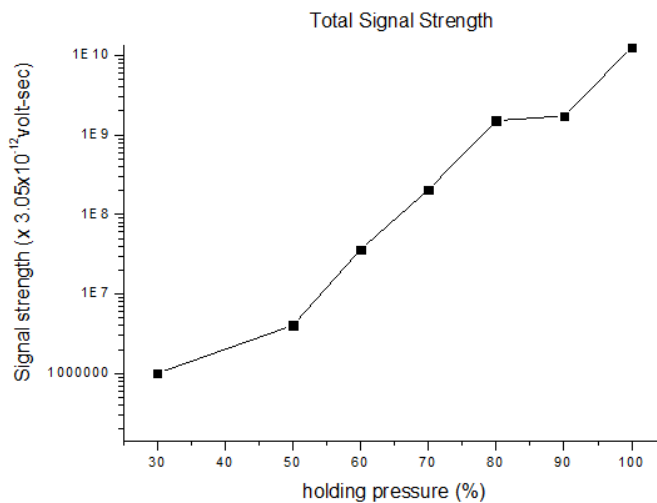

Figure 12. Total signal strength during load holding

3.1.3. Distribution of AE signal during the holding time

I did not use the signals during the initial 2 minutes among the 10 minutes to minimize the flow noise which often includes the initial stages of pressing in the pressure test. After that, I observed the number of hits and creep effect of the sound emission signals which occur during the holding time. Even though there were creation and growth of cracks on substrate under the load of 60 % of the estimated burst pressure, they did not cause much damage to the vessel. But it was found that at the load of 70 % pressure, the vessel was quickly destroyed.[4] Figure 13 shows the distribution of amplitude of signals occurring after 2 minutes of the pressure holding at each load. At the load of 60 % or less, there were not a lot of signals of 60 dB or higher but less than 70 dB. At this time, I could estimate that at the initial stage of the vessel damage, the composite material substrate wrapping around the vessel were showing some cracks and their growth. I could observe the cracks with my own eyes at the 2000th cycle of fatigue test when the pressure was at 207 bar. The used pressure was more than 30 % of the estimated burst pressure (180 bar). During the burst test, at the

load of 30 % to 60 %, even though there was increase in the number of signals, there was not a big increase in amplitude. Accordingly, we now that up to 60 %, there is not much of a creep affect but just the low amplitude of signals. I think that this is mainly caused by the creation and growth of cracks of substrate. After pressing, there were the creep effects, which show the significant increase in AE signal and the signals with the amplitude of 85 dB. In addition, as the distribution of amplitude appears different from the previous one, I think that the damages on the vessel are significant. It seems that there are more creations and growths of cracks in the composite materials and the cutting of reinforcement fiber and peeling of substrate cause the damage mechanism. In addition, the slope of the distribution of amplitude is known to be related to the mechanism of the signals[8], In the load of 70 % or higher, the slop looks similar, meaning that the damage is caused by the similar damage mechanism.

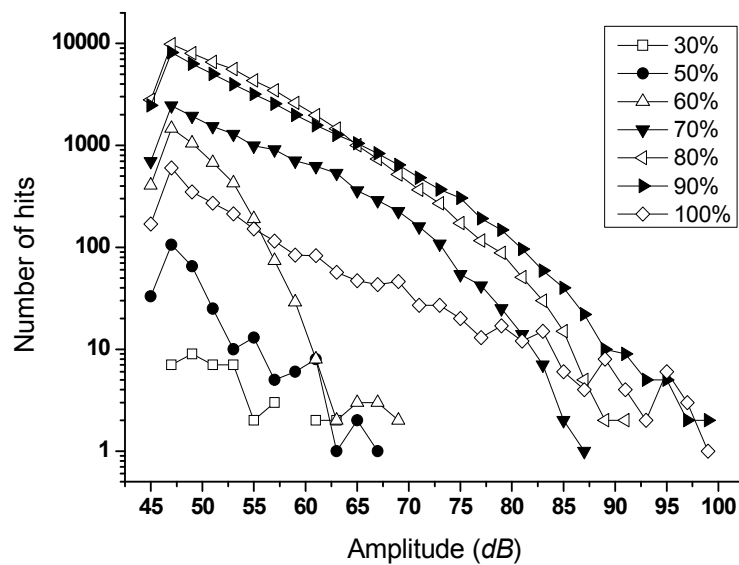

Figure 13. Amplitude distribution during load holding

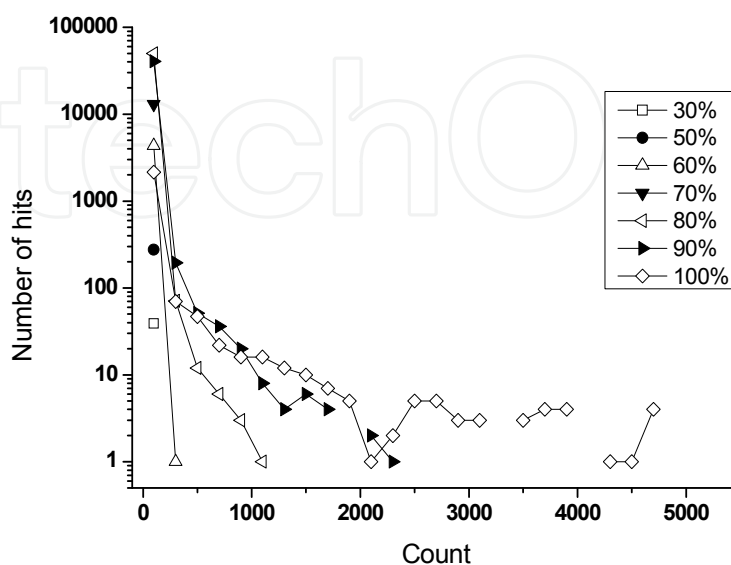

Figure 14. Count distribution during load holding

Figure 14 shows the distribution of counts of AE signals coming from each load of pressure. When the signal with counts of 500 or less occurred under the load of 60 %, the damage was caused by the creation of growth of substrate crack under the load of 60 % pressure. At the pressure of 80-90 % where the significant damage is done to vessel, the number of counts was 1000 or more. At the burst stage the number of counts was 2,500 or more.

Figure 15 shows that the duration of signal occurs with the range of 500 μs at the load of up to 70 % and that the signal of over 10000 μs started to appear at the load of 80 % or higher. At the load of 90 %, the 20000 μs appears during the final burst stage where the signals of 25000 ~ 50000 μs appeared.

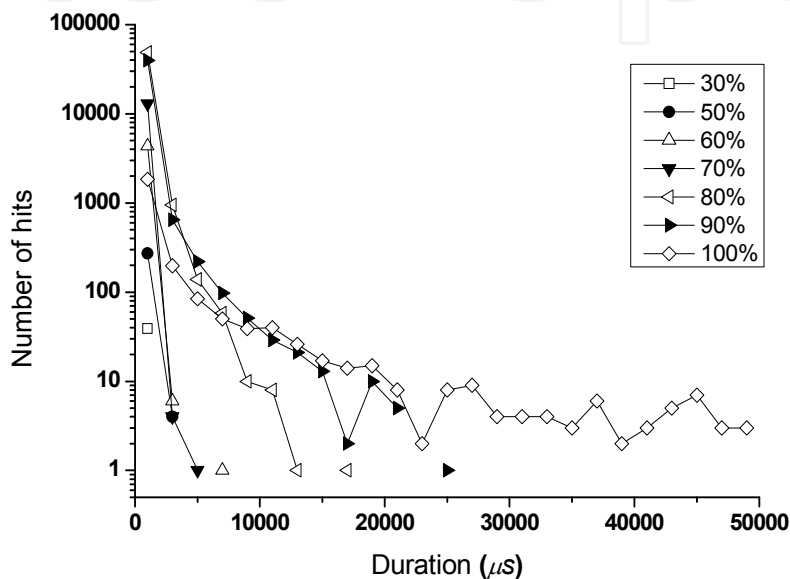

Figure 15. Duration distribution during load holding

Figure 16 shows the rise time of 100 μs or less and the signal of 100-200 μs at the load of up to the initial 30 %. As we understand the distribution of the amplitude from the fatigue test of 20,000 cycles, there may be no mechanism other than the creation and growth of cracks at the load of 30 % pressure. It means that the signal of 200 μs or less is caused by the creation and growth of cracks of the vessel materials. Even though there were 1 and 4 signals of 300 μs or higher at the load of 50-60 %, they are negligible considering the total number of signals. It seems that the damage was mainly caused by creation and growth of cracks on composite materials rather than by new damage mechanisms. At the load of 70 % pressure, the signal of 250-450 μs , which is longer than at previous load stage appeared, meaning that there may be new damage mechanism. It seems that it was caused by the additional damage mechanism such as the cutting of reinforcement fibers and interlayer peeling due to the increase in internal pressures. At the load of 80-90 %, the rise time of 500 μs or more is observed. It may be affected by the composite damage mechanism such as the growth of existing cracks, cutting of reinforcement fiber and inter-layer separation happening at the neighboring location. This trend is true of the distribution of counts and durations as specified above. The observation of the sound emission signals coming out of the neighboring location through the composite damage mechanism would be a good tool to assess the vessel.

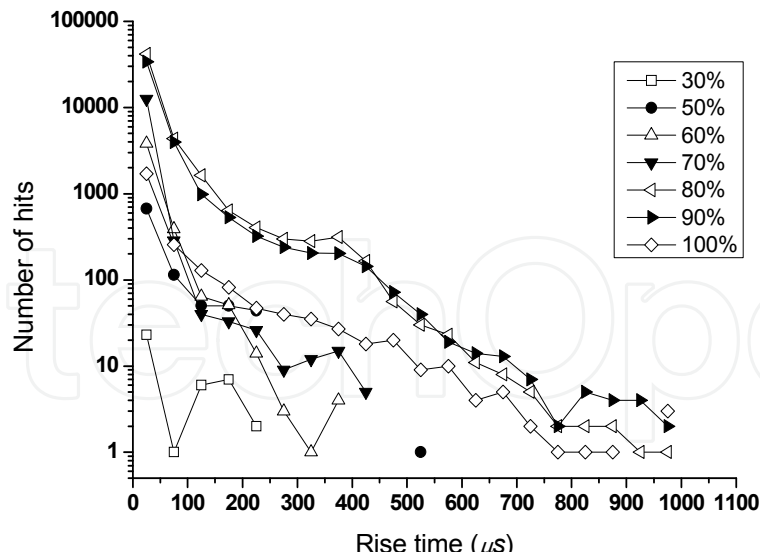

Figure 16. Rise time distribution during load holding

3.1.4. Mean frequency of AE signal during the holding time

To estimate the damage with the sound emission signal, the signal of 60 dB or higher is used. Figure 17 shows the distribution of amplitude for hits of 60 dB or higher for each load of pressure. AE time becomes lower until the pressure of 70 % but at 80 %, it becomes faster. As the pressure rises at constant pace during the test, at 70 % pressure, there is no AE signal until 60 % pressures, showing the Kaiser effect. Accordingly, up to 60 % pressure, it looks like that there was no significant damage to the vessel. As the pressure rises up to 70 % that may have damaged the vessel, it looks like that AE happened due to the Felicity effect when the pressure goes up to 80 % as the vessel was damaged during the rise up to 80 %. At the 90 and 100 % pressure, there is the Felicity effect. Particularly, in the pressure range of up to 100 %, which experienced the load of 90 % or higher, there is AE signals of 60 dB or more from the beginning, showing that the damage is significant. In the actual burst test, the damage mechanism of Type II vessel, or the matrix crack in the direction of initial hoop occurs and then the creation of cracks and its growth and the interlayer separation (which belongs to matrix crack but has different damage mode) occur [4]. At the load of 60 %, the matrix crack in the direction of hoop was shown. But, the matrix crack in the direction of hoop did not affect the burst pressure of the vessel [8].

Figure 18 shows the count of hits where sound exceeds 60 dB at each stage of burst test. The rate decreases from 7 % to 1 % during the pressure of 30 % to 60 %. Then, the signals of 60 dB or higher rapidly go up to 20% at the load of 70 %. The rate goes up to 30 % at the load of 100 %. The signals of 60 dB or higher at an early stage may be caused by the creation of matrix crack on the composite materials. The reduction thereafter may be caused by the low amplitude (60 dB or less) rather than the creation of crack. At the load of 70 % or higher, there are not only the matrix cracks but also the damages by the new damage mechanism such as the cut of fibers, increasing the signals of 60 dB or higher. The measurement of the count of hits which are 60 dB or higher is a good tool to assess the damage.

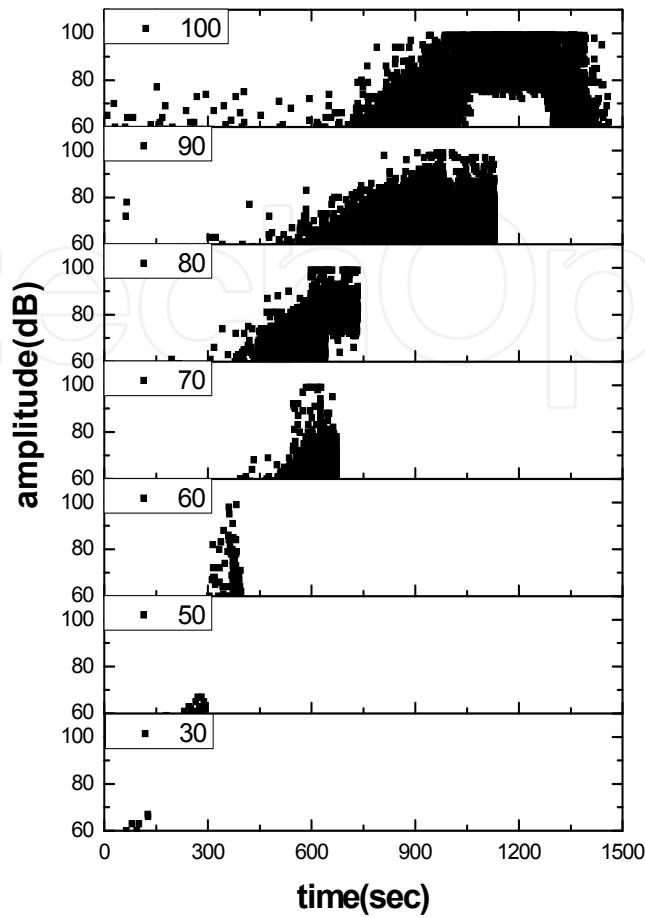

Figure 17. Amplitude distribution during loading at each loading stage (over 60 dB)

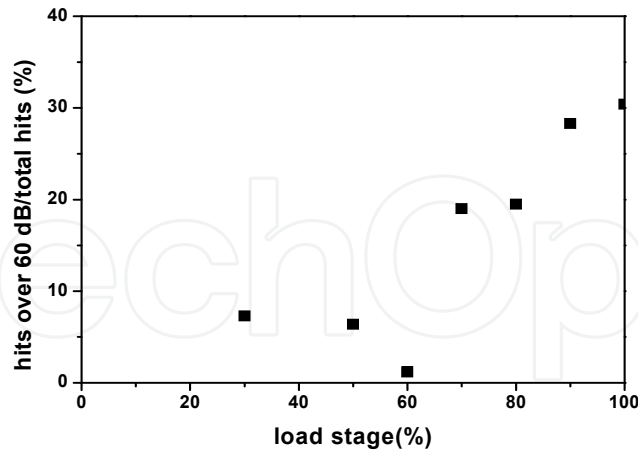

Figure 18. Ratio of hits over 60 dB / total hits during each loading stage

Figure 19-21 show the mean initial, reverberation and average frequency of AE signal at each load stage. The frequency is obtained not from the analysis of wave form but from the duration and counts. The frequency shows the difference between above and below 70 % load. As for the initial frequency, it did not show a big change at the load of up to 60 % or 100 kHz but it goes up at the load of 70 % until going down a little. This is likely to be

related to the source mechanism. It shows the creation and growth of matrix crack at the load of up to 60 % and the additional damage mechanism such as the cut of fiber at the load of 70 % or higher. The reverberation frequency shows a little difference between below and above 70% but is constant in most stages while the average frequency was also constant with a little rise at the load of initial 30 % pressure.

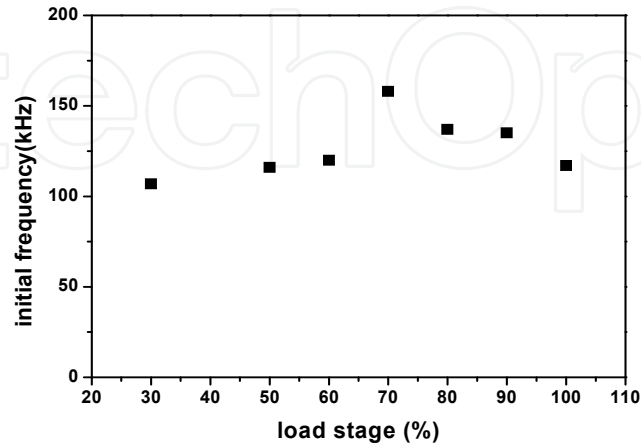

Figure 19. Mean initial frequency during each loading stage

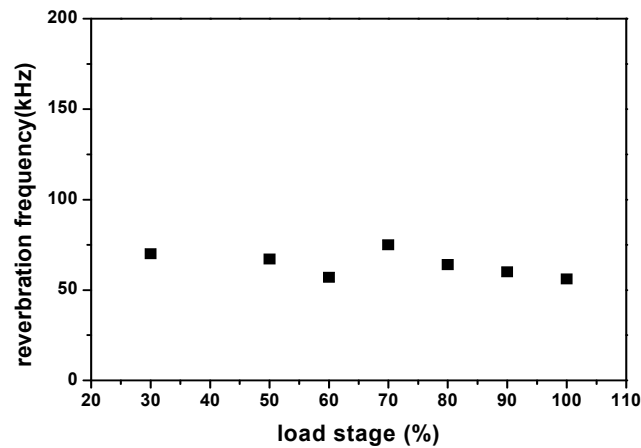

Figure 20. Mean reverberation frequency during each loading stage

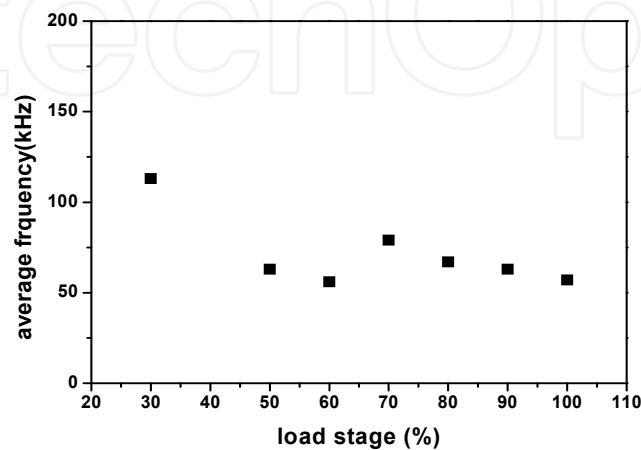

Figure 21. Mean average frequency during each loading stage

3.2. Fatigue test

3.2.1. Identification and Verification of Acoustic Emission Location

Figure 22 shows the results of measuring the elastic wave speed of the artificial acoustic emission source for the acoustic emission location on the fiber-wrapped composite material. As shown on the picture, the speed of longitudinal elastic wave was 4512 m/sec and the elastic wave speed of the wrapped direction was 5689 m/sec showing the characteristic of anisotropy. Thus, the location was identified using anisotropic vessel source location that uses the difference of time for the acoustic emission signal is to be reached.

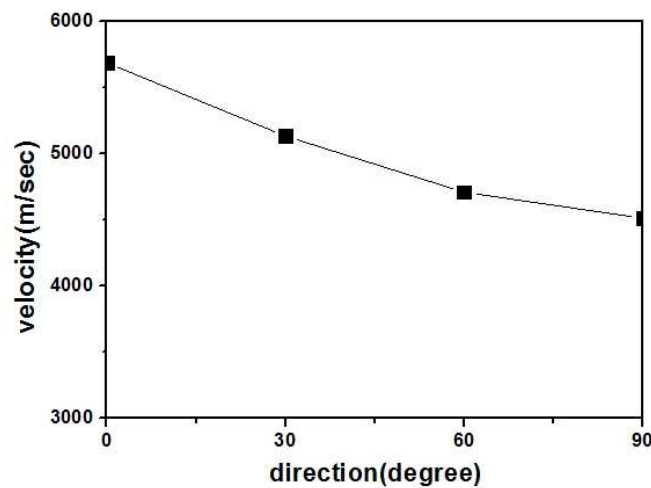

Figure 22. The elastic wave velocity with degree between propagation and wrapping direction

Figure 23 is the location of the sensor and the result of the identification test of the location using the artificial acoustic emission source. The four sensors were attached in staggered locations in channel 5, 6, 7, 8 and channel 7 refers to the backside of 8. The acoustic emission source is located diagonally in equal intervals between channel 5 and 8 and between channel 6 and 8.

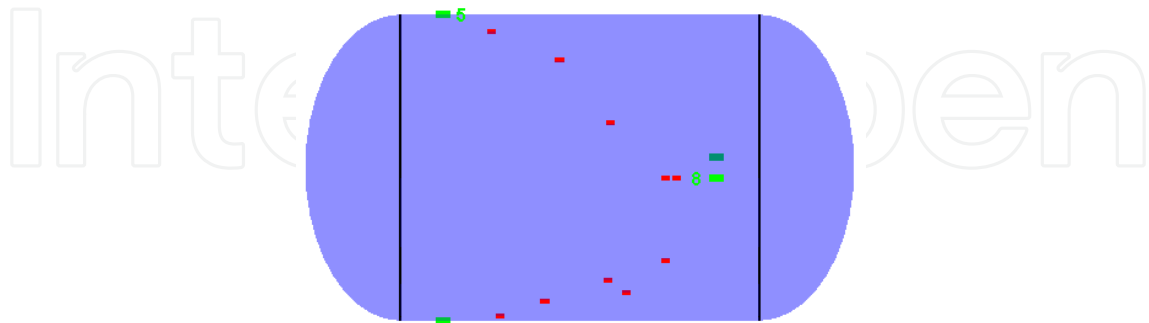

Figure 23. Confirm of Source location

3.2.2. Fatigue Test and Location of Artificial Defect

Figure 24 shows the size of the artificial defect realized on the composite material which is wrapped and the length is 50 mm, width 3 mm, and the depth is 3 mm which is 50 % of the

thickness of the wrapping composite material. The direction of the realized defect was longitudinal and transverse, two types of artificial defects.

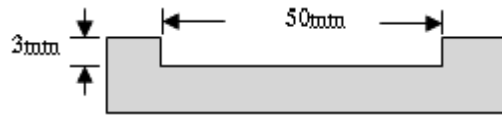

Figure 24. Schematic diagram of artificial defect

Figure 25 shows the average number of hit per sensor during the fatigue test of vessel. The vessel with the artificial defect has more number of hits compared to the sound vessel and when you see the tendency in increase and decrease, the number of hits for transverse defect vessel and sound vessel decreases as the number of cycle increases; however, the number of hits for longitudinal defect vessel decreases in 4000 cycle and then increases and then decreases in 8000 and 12000 cycles.

The reason the number of hit in the early stages is big is related to the initiation and growth of the matrix rupture in the comparatively weak areas within the vessel. The number of hits decrease and the initiation and growth of ruptures are comparatively slowed until sufficient amount of resilience is stored to bring about new initiation and growth.

In the case of longitudinal defects vessel, the amount of resilience needed to bring about progress in the defect (growth of rupture) is comparatively smaller than other vessel, so in the 8000th and 12000th fatigue test, the number of hits is bigger than in other vessel and because there is a need for another accumulation of resilience, the number of hits decrease afterwards. Such phenomena are clearly distinct in the composite material as mentioned in the introduction and in the early stages of damage, resilience increases like the number of hits and when there are some increases in damage, the resilience afterwards is comparatively low.

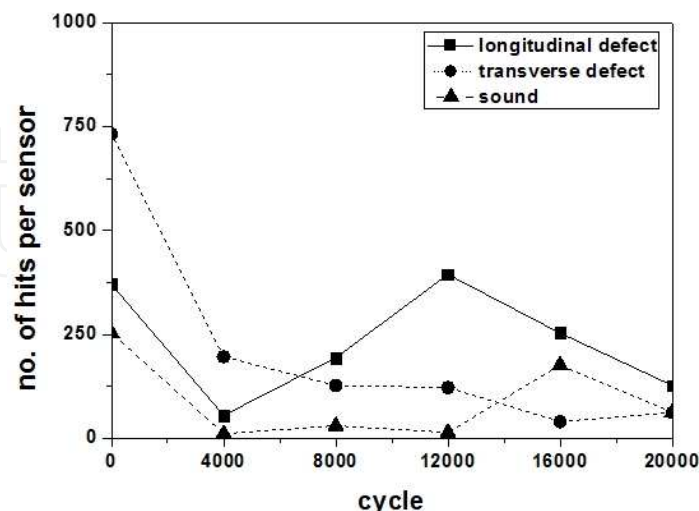

Figure 25. The number of hits per channel during fatigue test for artificial defect and sound vessel

Figure 26 shows the number of events extracted during the fatigue test on longitudinal defect and transverse defect vessel. An event shows the number of sources calculating the

location of the acoustic emission source within vessel using the acoustic emission signal that hit the sensor and in the case transverse defect vessel which includes a transverse defect, the number of events is noticeably decreased as the number of cycle increases, but in the case of longitudinal defect vessel which has longitudinal defect, the number of events increases a lot in 8000th cycle and does not change much as the number of cycle increases.

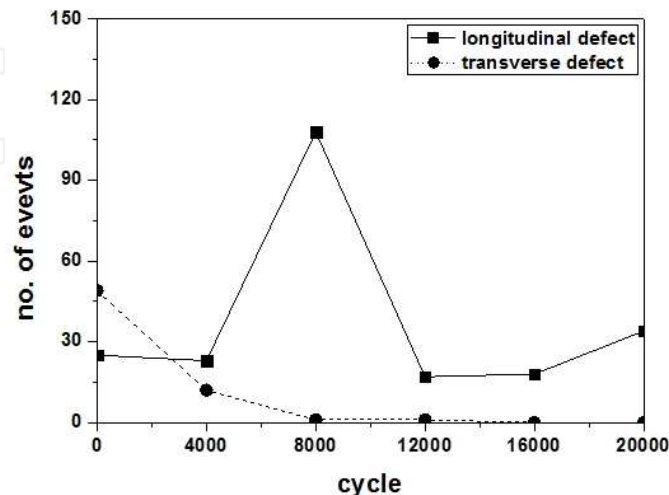

Figure 26. The number of events during fatigue test for artificial defect vessel

Figure 27 compares the number of hit per sensor and the number of events using Figure 25 and 26 and shows the event/hit ratio according to the increase in the number of cycle. This is a figure that shows the % of the number of hits that can precisely show the source among the total number of hits. In the case of longitudinal defect vessel, it was 41.8 % in the 4000th cycle, 55.7 % in the 8000th cycle. An event can be calculated using the difference in time that the resilience from the source (acoustic emission signal) sent through the walls of the vessel reaches the sensor and has to be extracted from at least 3 sensors. Hits that do not go by such standards cannot be used to calculate events and if the location was identified by simulation or if the signal is weak or is static, it cannot be recorded as an event. In the case of longitudinal defect vessel, the number of hits is small in the 4000th and 8000th cycle but the growth of the rupture is relatively easy and it sends hits to at least 3 sensors with signals with sufficient amplitude so the number of event/hit rate increases.

Figure 28 is the result of the location due to the acoustic emission test performed during the fatigue test on longitudinal defect vessel. Figure 28 (a) shows the location of 25 events during the first 3 fatigue test cycles. It does not show the location of artificial defects but shows the overall looks on the whole vessel. Such results are not shown in pictures but also in transverse defects vessel, 49 events in Figure 26 shows looks like a) on the whole vessel and it seems that signals were created on the weakest areas of the whole vessel when the first pressure was put. In the case of b), after the 4,000th cycle, in the 3rd fatigue test, 23 events were shown to be clustered around the artificial defect. As for the vessel with transverse defects, after the 4,000th fatigue test cycle, in the 3rd fatigue test, 12 events were created but they were all over the whole vessel so we could not show the location of the artificial defect.

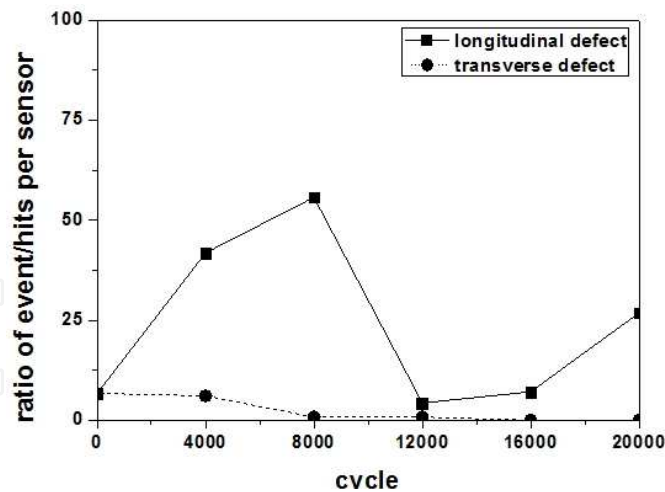

Figure 27. The ratio of events/ hits per sensor during fatigue test for artificial defect vessel

In the case of c), in the 8000th fatigue cycle, 108 events were clustered around the artificial defect and as mentioned in the explanation in Figure 27 more than 50% of the occurred hits were signals related to the artificial defect. Afterwards, events that occurred in d) ~f) were those that mostly occurred near the artificial defect so we can acknowledge that the damage on the composite material is progressed around the artificial defect. Figure 29 shows the surroundings of the longitudinal artificial defect after the 20000th cycle and shows that at the end of the defect, there is a matrix rupture progressing in a hoop-direction and although not clear in the picture, at the end of the depth in the artificial defect, delaminating was observed on the overall defect. In the case of vessel with transverse defects, after the 8,000th fatigue test, less than 1 event was created and the location of the artificial defect could not be shown clearly.

On the other hand, after the 20000th fatigue test, in the burst test, the location of the burst is marked in c) of Figure 28 and events are also observed in a), d), e), and f). The source of the acoustic emission signal is assumed to be the fatigue rupture in the weak areas of the steel liner rather than in the composite material. The final burst in the case of the longitudinal defect accompanies matrix rupture and delaminating as mentioned above during the fatigue test and burst test so the whole vessel area, which is the length of the defect, is thinner in terms of thickness like the depth of the defect and thus is weaker than other areas and it is thought that it burst at the final burst location in which the fatigue rupture occurred in the steel liner.

3.2.3. AE parameters during fatigue test

Figure 30 shows the relationship between the amplitude of the signal occurring during the early three cycles and the rise time, and can be clearly distinguished as around 10 μ s and over 100 μ s and the grey mark shows the rise time while holding the load during the three cycles and also at 90 %, which is the highest, has a rise time of about 10 μ s. Generally while load holding, it can be inferred that there is likely to be growth of an existent crack rather

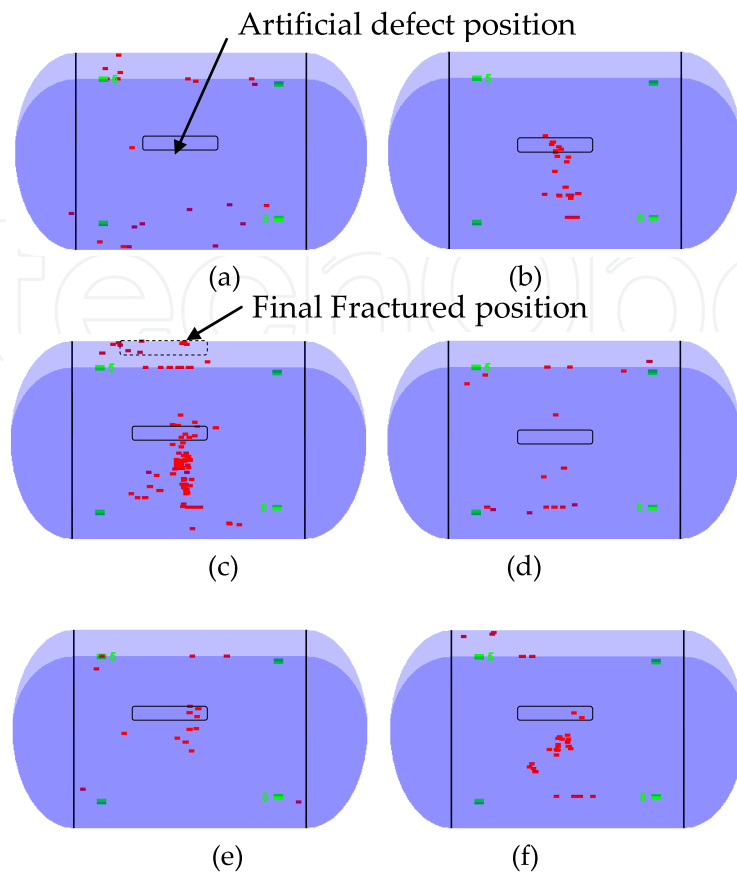

Figure 28. The result of source location with cycle for longitudinal defect : a)0, b)4000, c)8000, d)12000, e)16000, f)20000

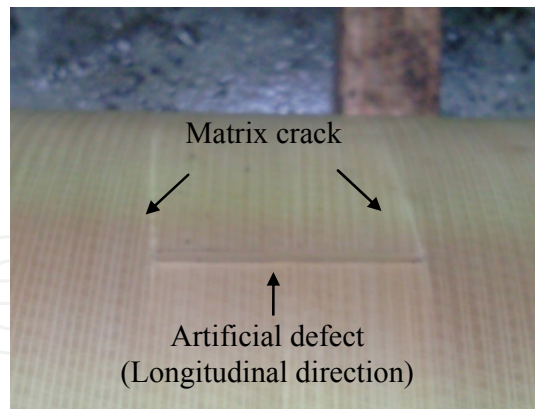

Figure 29. Longitudinal defect and matrix crack after 20000 cycle fatigue test

than initiation of a new matrix crack and thus can be said that it is a growth of crack around $10 \mu\text{s}$. And the rise time of AE signal which occurs during the initiation of a matrix crack can be said to be more than $100\mu\text{s}$. This accord to the result that the rise time of the AE signal occurring during the initiation of matrix crack during the burst test is around $100 \mu\text{s}$ and that the rise time of the AE signal occurring during the growth of the crack is around $10 \mu\text{s}$. [4]

On the other hand, in the case of a sound cylinder, after the 4000th fatigue test, the average rise time noticeably decreased and increased little up to the 20000th test. After the 4000th fatigue test, there are not many initiations of new matrix cracks and you can see the growth of the cracks created in early stages. On the other hand, in the case of vessel with defects, the average rise time of related hits for events occurred during the first three fatigue test was 56 μs and afterwards decreased to 34 μs after the 8000th cycle and increased to 82 μs about after the 12000th cycle and then decreased again.

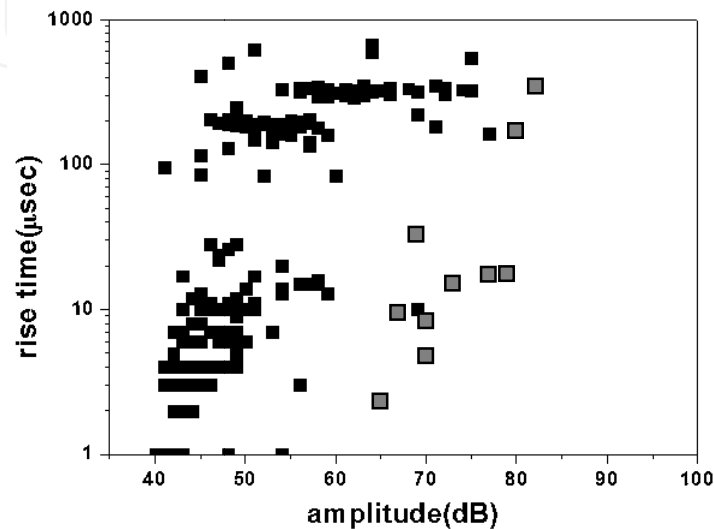

Figure 30. The rise time distribution during initial 3 cycles for sound vessel

Figure 31 a) shows the relationship between the amplitude of the signals of events occurring during the first three cycles of the vessel and related hits and rise time and is clustered around 10 μs in the figure and is also scattered around 100-800 μs . It is judged that the initiation and growth of matrix crack will happen in weak areas of the overall vessel. Especially, a higher rise time can be observed when the source forms a cluster around the defect as shown in b), c), e), f) of Figure 31 than when the source is scattered overall on the vessel like a) or d) so the growth of cracks around the defect has a lower rise time than the initiation of cracks.

On the other hand, after the 4000th fatigue cycle, the average rise time of the signal occurring in defect vessel are shown to be higher than the average rise time of signals occurring in sound vessel.

In the case of a sound vessel, the growth of individual cracks occurs far away in other cracks. But, in the case of vessel with defects, the growth of multiple cracks occurs around the defects because the elastic energy needed for the growth of matrix crack in the vessel with defect is smaller than that of sound vessel. And generated signals overlap with other signals. Therefore, the rise time of signal is extended.

Generally, in order to analysis of frequency, we use wideband sensors to detect signals, and analyze by the Fourier transform of detected signals. However, because the sensitivity of wideband sensors fall behind resonant sensors, signals are also detected using resonant sensors

and the frequency is calculated by rise time, duration, and count. Frequency by calculation was used and analyzed in this research because resonant sensors were used for the source location.

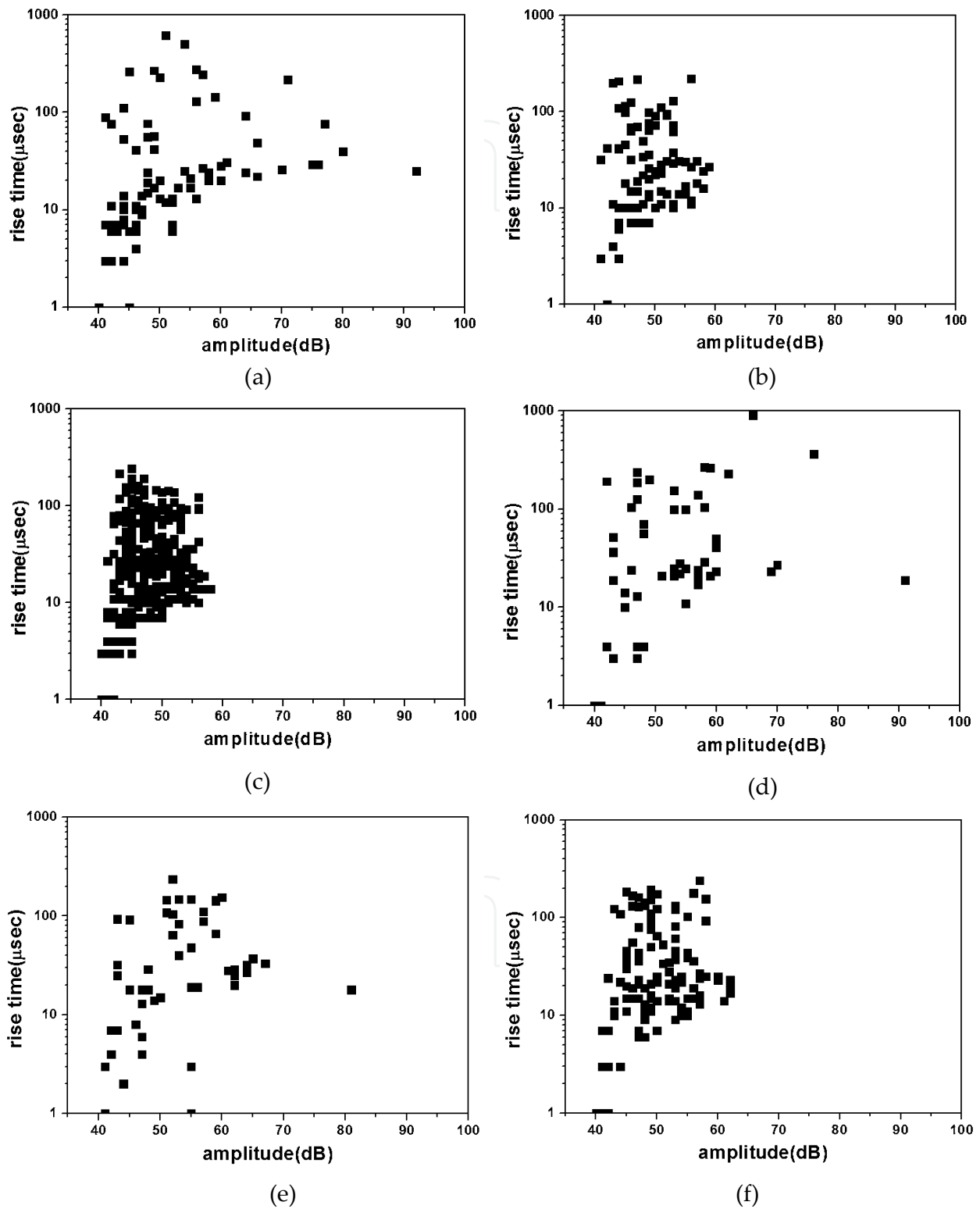

Figure 31. The rise time distribution of hits connected with event during fatigue cycle for longitudinal defect vessel: a) 0, b) 4000, c) 8000, d) 12000, e) 16000, f) 20000 cycles

Figure 32 shows the distribution of initial frequency versus the amplitude with fatigue cycle but it is dispersed around 100-200 kHz, which is unrelated to the fatigue cycle. It is in accord with the result that the average frequency of signal which is generated due to initiation and growth of matrix crack is around 100 kHz in the burst test using resonant type sensors [7].

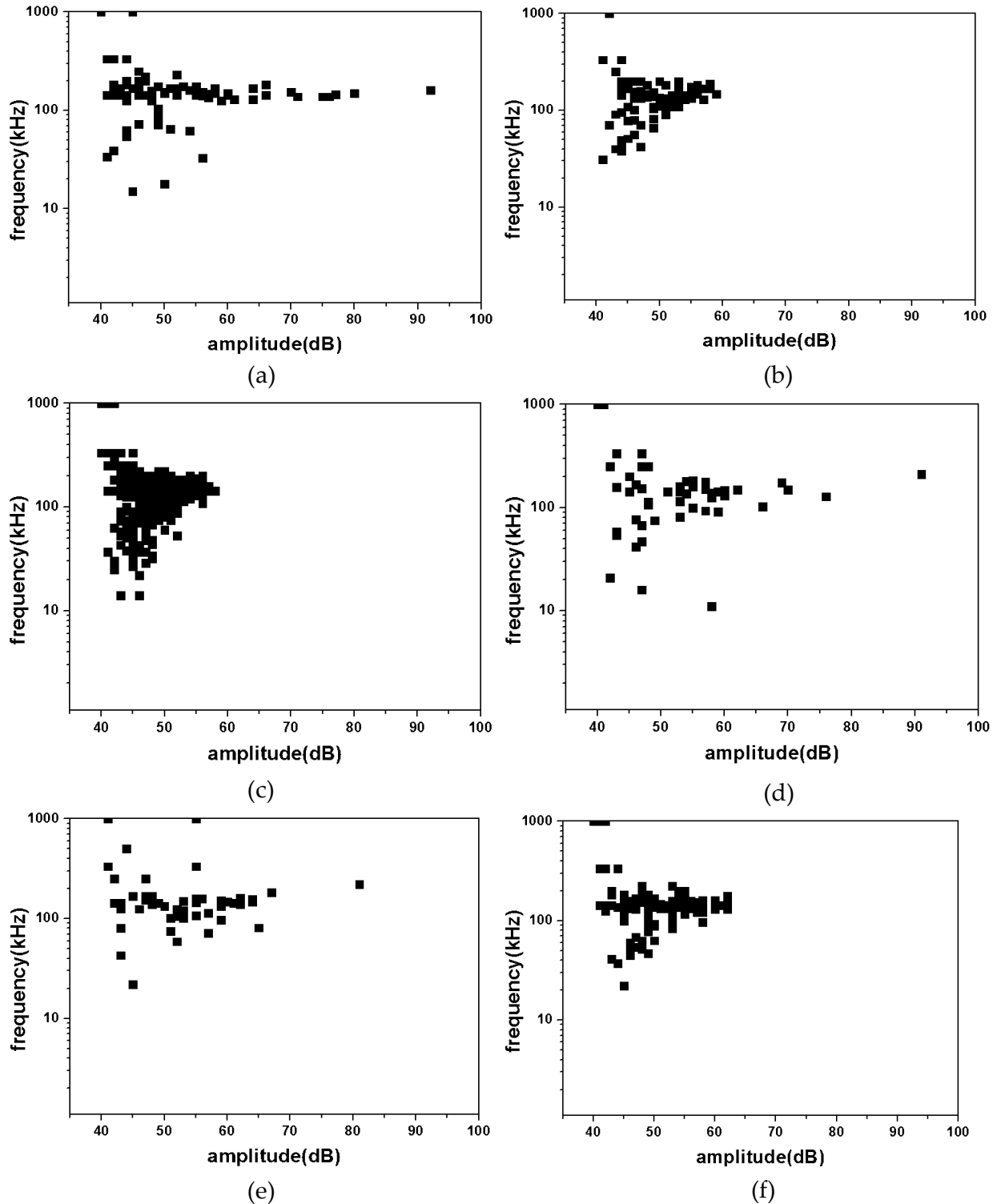

Figure 32. The initial frequency distribution of hits connected with event during fatigue cycle for longitudinal defect vessel: a) 0, b) 4000, c) 8000, d) 12000, e) 16000, f) 20000 cycles

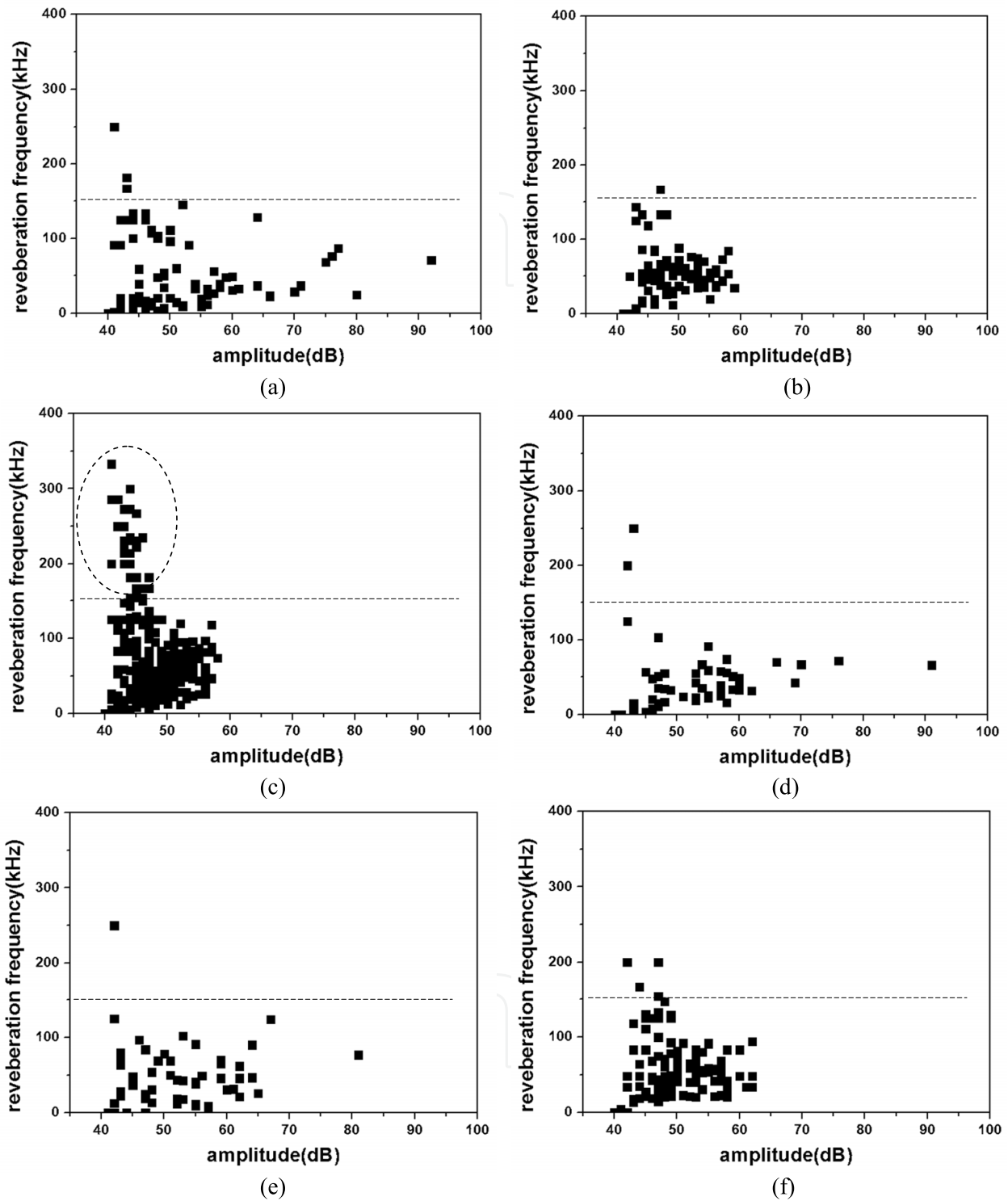

Figure 33. The reverberation frequency distribution of hits connected with event during fatigue cycle for longitudinal defect vessel: a) 0, b) 4000, c) 8000, d) 12000, e) 16000, f) 20000 cycles

Figure 33 shows the distribution of reverberation frequency on amplitude according to the number of fatigue tests but besides the oval area in Figure 33 c) which is the result of the 8000th fatigue test, most are dispersed below 150 kHz. The average reverberation frequency

on signals relating to all events of Figure 33 c) was 73 kHz and these accords to the fact that the average reverberation frequency is between 50 - 75 kHz in all stage of burst which includes the damage mechanism of composite materials in the cast of burst test.[7] On the other hand, the reverberation frequency during the burst test of the same vessel was known to occur in all stage of the burst test in the range of 150 - 350 kHz[8], and in such case, because it includes the mechanism of all damage, it is hard to differentiate damage mechanism as a frequency. There were 23 event signals that had a reverberation frequency in the 150 - 350 kHz area in Figure 33 c) and 16 of them, which are 70 %, occurred in the matrix crack area of Figure 29, which is an observation of artificial defects after the 20000th fatigue test. More than 90 % of the related 44 hits(150 - 350 kHz) were signals with rise time lower than 100 μ s and average rise time of 31 μ s. As mentioned in 3.2.1, it is assumed that it is due to the growth of matrix crack.

3.2.4. Amplitude distribution slop during fatigue test

Figure 34 shows the amplitude distribution of accumulated hits according to the number of fatigue test and its slope has two types of shapes. Generally, the slope in the amplitude distribution of accumulated hit is known to be related to the mechanism of the source [8] and in vessel with defects as used in the experiment, as mentioned in the previous chapter, it includes mechanisms such as the initiation of matrix crack, growth of the created cracks (including delaminating), and the initiation and growth of liner fatigue cracks.

Initiation and growth of liner fatigue crack will be mentioned in the following chapter and in the view of the estimated result of the damage mechanism according to the number of fatigue explained in the previous chapter, the case of the initiation of matrix cracks is estimated to have a slope of ①(0.04) and the growth of cracks, a slope of ②(0.12).

In order to analyze the characteristics of acoustic emission signals that occurred in the final burst position, event signals observed around the final burst location within 200 mm hoop direction in terms of length as marked in Figure 29 were analyzed. 18 events were occurred during the 20000th fatigue cycle and the number of related hits was 59. Figure 35 shows accumulated amplitude distribution and there are only 3 that are over 60 dB and 49 of them are below 50 dB. You can see the slope as ③ but if you observe closely, it is possible to observe that the same slope exists as ① in Figure 34 and also that it include the initiation of matrix crack. Seeing it as showing the slope of ③, as a signal according to a sole damage mechanism, it is estimated to be related to liner damage and the size is 0.06

Figure 36 shows the distribution of rise time on the amplitude of the signals occurred in the final burst location. There is almost no rise time above 100 μ s and is dispersed around 10 μ s. It can be thought that the rise time which occurs during the growth of steel liner fatigue crack is similar to that during the growth of matrix crack.

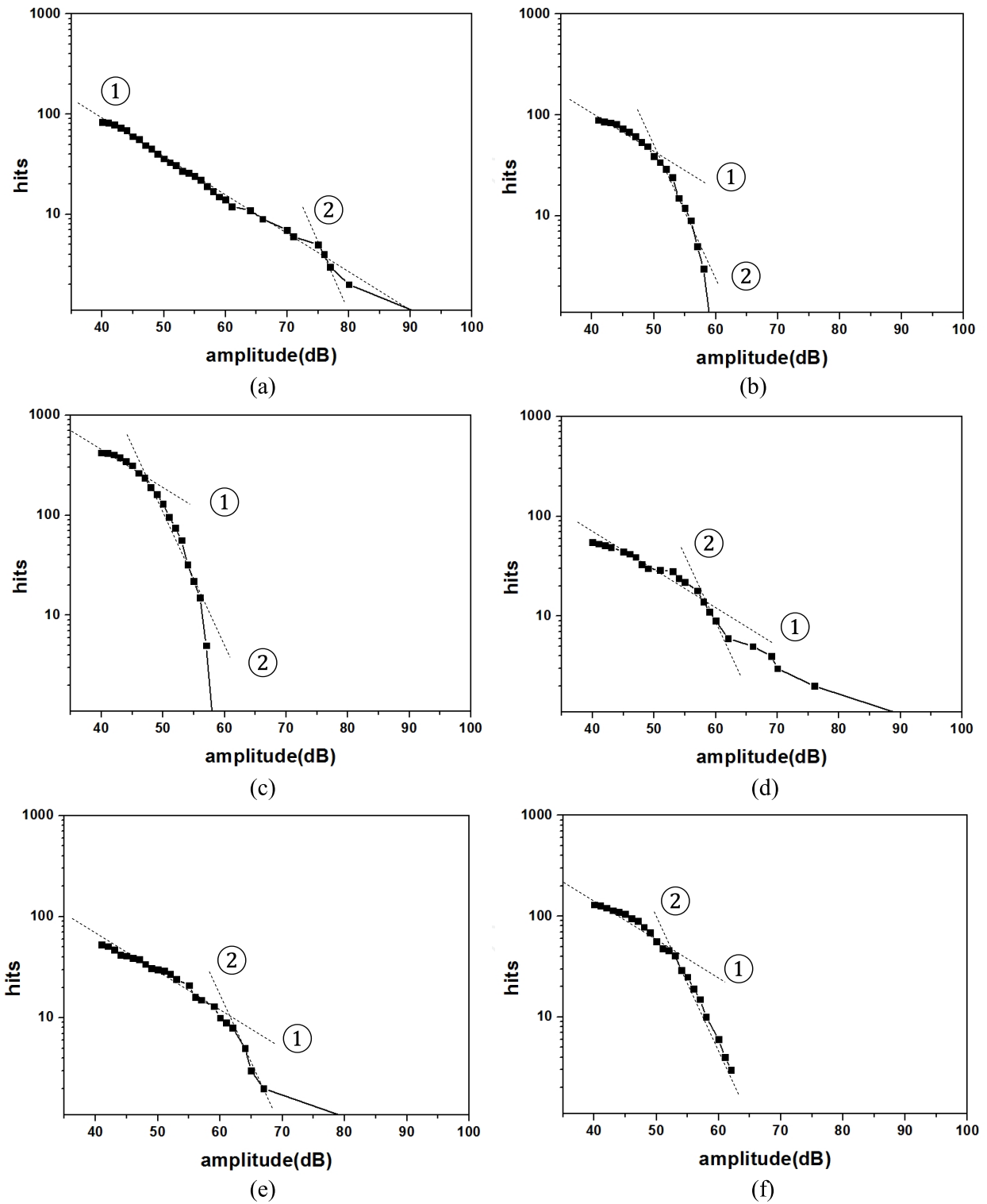

Figure 34. The amplitude distribution of accumulated hits connected with event during fatigue cycle for longitudinal defect vessel: a) 0, b) 4000, c) 8000, d) 12000, e) 16000, f) 20000 cycles

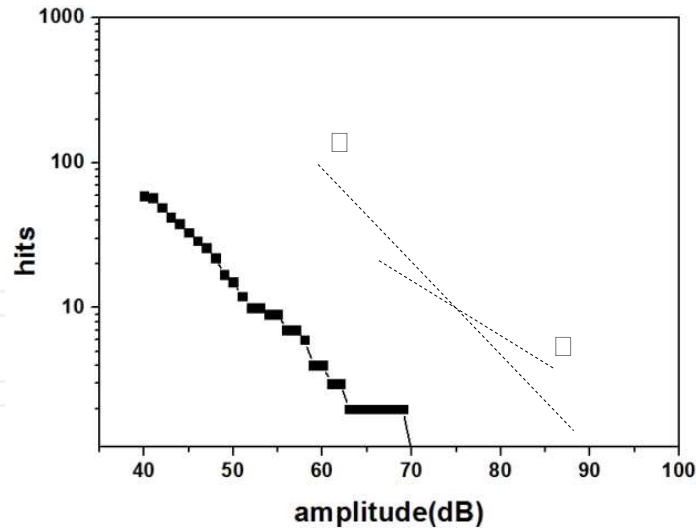

Figure 35. The amplitude distribution of accumulated hits connected with event during fatigue cycle for longitudinal defect vessel

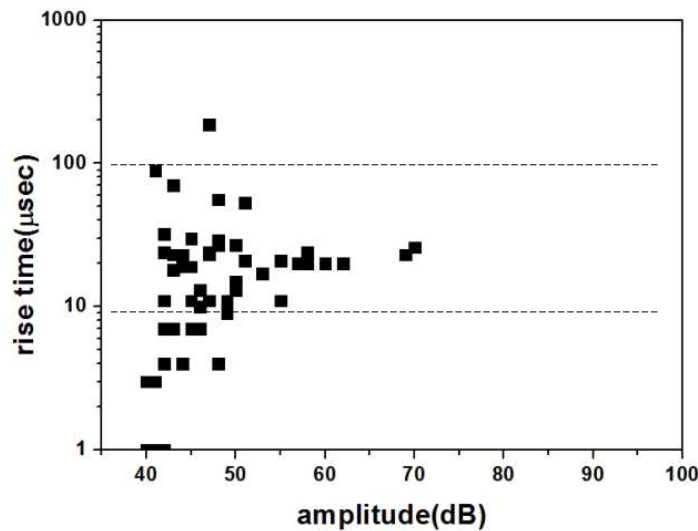

Figure 36. Distribution of rise time on the amplitude of the signals

3.2.5. Burst test after 20000 cycles fatigue test

We burst the vessel with two types of artificial defect after carrying out 20000 cycles fatigue test on a sound vessel and continuously increasing the pressure where the burst pressure is 590~615 bar with the difference in the pressure of the vessel were within 5 % and thus was irrelevant to the existence of defects.

Generally, 20000 cycles of fatigue is equivalent to a vessel used for more than 50 years if you are to put pressure on the vessel once a day although, of course, in the case of a real gas vessel, gas is used as a pressure medium so it may be different from the case in which machine oil is used as a pressure medium, but if the vessel with artificial defects and sound vessel were tested in the same conditions, the burst pressure is shown to be almost the same. Thus, in the case of the size of artificial defect used in this research, the direction of defect is shown to have almost no effect on the life of the vessel.

Figure 37 is a picture that shows the burst location in the vessel with the artificial defect. As shown in the picture, we can see that in the case of a vessel with a transverse defect, the final burst location is in the general burst location (cylinder and head area) for a well-constructed type II vessel. However, in the case of a vessel with a longitudinal defect, in both vessels, the final burst location was within the transverse vessel in which the defect was located. We think that this is because in the case of the longitudinal defect, the wrapped fiber is cut in 3 mm depth and in 50 mm length so the effect in which the thickness of the composite material is big, but in the case of the transverse defect, the fiber is cut only in 3 mm depth and in 3 mm length so the effect is small.

In this research, we cannot precisely know how much the depth of the defect has to be in order for the final burst pressure to change; however, the direction of the defect and the final burst location do have a correlation and we can infer that the longitudinal defect has a bigger effect on the final burst location.

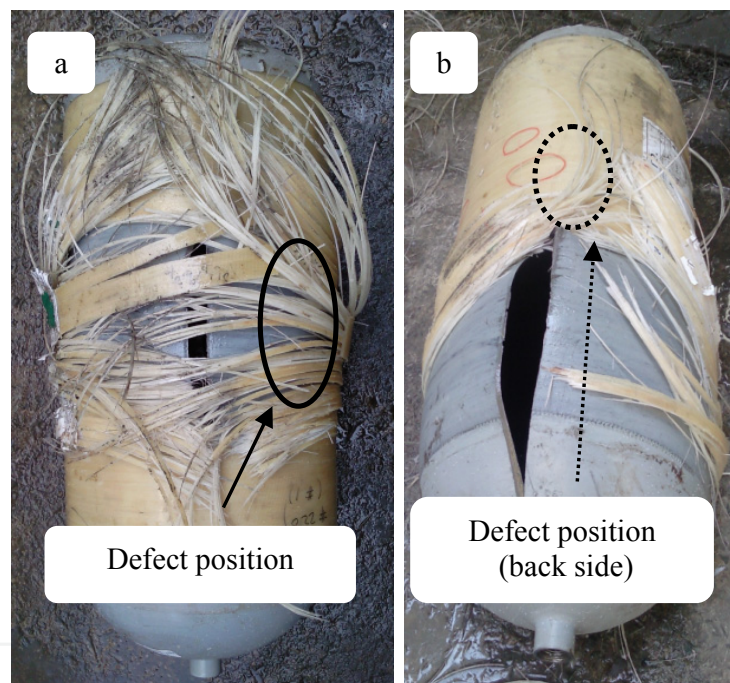

Figure 37. Position of artificial defect and burst location : a) longitudinal, b) transverse

4. Conclusion

4.1. Burst test

By increasing the loading of pressure up to the expected burst pressure, I obtained the sound emission signal during 10 minutes holding time after loading. Considering that there would be flow noises during the initial 2 minutes, I obtained data for the remaining 8 minutes except the initial 2 minutes to analyze the AE variables.

1. Up to 360 bar, or 60 % of the estimated burst pressure, which is equivalent to 1.8 times of the usage pressure, it seems that there is little creep effect as there is little damage to

- the vessel. If the pressure is over 420 bar, or 70 % of the estimated burst pressure, the damage to the vessel becomes greater, meaning that the creep effect becomes larger.
2. The sound emission signal variables such as mean amplitude, mean rise time, means duration, and rise time amplitude correlation can be obtained when the vessel is damaged at each stage of pressure load. Though the variables were not enough to evaluate but were effective to estimate the damage mechanism.
 3. It was discovered that the total count, and total signal strength at the pressure holding stage were the sound emission variables, which represent the degree of damages on the vessel.
 4. The rate of number of hits with 60dB or higher in amplitudes in the number of total hits is likely to indicate a damage of vessel.
 5. We can estimate the damage mechanism through mean rise time, mean amplitude and frequency analysis.

4.2. Fatigue test

After manufacturing a sound vessel and a vessel with artificial defect for the composite vessel, we executed acoustic emission test during fatigue test and came up with the following conclusion.

1. Vessel with two types of artificial defects (longitudinal and transverse) and a sound vessel was put in 20000 fatigue test and the pressure was continuously increased and then was burst, the burst pressure was 590~615 bar and the differences in pressure on the vessel were less than 5 % and was not relevant to the existence of defects.
2. There is a correlation between the direction of defect and the final burst location and the longitudinal defect had a greater effect on the final burst location of the vessel rather than the transverse defect.
3. Acoustic Emission Signal, which occurs during the fatigue test, occurred more in vessel with defects rather than in sound vessel, and as the number of fatigue test accumulated, the number of hits increased more in vessel with longitudinal defects than in those with transverse defects.
4. In the case of vessel with longitudinal defects, events were clustered around the artificial defect and more than 50 % of the occurred hits were signals that were related to artificial defects and the source location was precisely found on the defect location but in the case of vessel with transverse defect, events rarely occurred and even if they occurred, the source location relevant to a defect did not match.
5. Longitudinal defect of the vessel created matrix rupture and delaminating of the composite material during the fatigue test and the burst test and the thickness of the whole vessel area became thinner like the length of the defect and thus was weaker than other areas of the vessel. And the final burst was at the location in which the fatigue rupture of the steel liner occurred.
6. The position of the longitudinal defect was shown well using the identification of acoustic emission location during the fatigue test and the average rise time of acoustic emission signal related to events occurring here was about 30-90 μs and signals with a shorter rise time can be observed more in the growth rather than in the initiation of matrix cracks.

7. The initial frequency is distributed around 100-200 kHz and signals with reverberation frequency higher than 150 kHz are related to the growth of matrix cracks.
8. The slope of accumulated amplitude distribution is about 0.04 during the initiation of matrix cracks and is about 0.12 during the growth. However, signals estimated to be liner fatigue crack growth have a slope of 0.06 and a rise time similar to that of during the growth of matrix cracks.

Author details

Hyun-Sup Jee and Jong-O Lee

Korea Institute of Materials Science, South Korea

5. References

- [1] Statics of korean Association for Natural Gas Vehicles (2009)
- [2] Mark Toughiry (2002) Examination Of The Nondestructive Evaluation Of Composite Gas Cylinders, United States Department of Transportation, NTIAC/A7621-18:CRC-CD8.1, 10
- [3] General Motors Corporation (1997) Development of Inspection Technology for NGV Fuel Tanks, FaAA-SF-R-97-05-04
- [4] H. S. Jee, J. O. Lee, N. H. Ju and J. K. Lee (2011) Study of acoustic emission parameters during a burst test for CNG vehicle fuel tank, *Journal of KSME*, 35(9), 1131
- [5] J. O. Lee, J. S. Lee, U. H. Yoon and S. H. Lee (1996) Evaluation of adhesive bonding quality by Acoustic emission, *Journal of KSNT*, 16(2), 79
- [6] H. S. Jee, J. O. Lee, N. H. Ju, J. K. Lee and C. H. So (2011) Development of in-service inspection for type-II gas cylinder, *Proceeding for Spring Conference of KIGAS*
- [7] H. S. Jee, J. O. Lee, N. H. Ju, J. K. Lee and C. H. So (2011) Damage Evaluation for High Pressure Fuel Tank by Analysis of AE Parameters *Journal of KSCM*, 24(4), 25
- [8] S. Yuyama, T. Kishi and Y. Hisamatsu (1982) Detection and Analysis of Crevice Corrosion-SCC Process by the Use of AE Technique, *The Iron and Steel Institute of Japan (ISIJ)*, 64(14),2019-2028
- [9] S. H. Paik, S. H. Park and S. J. Kim (2001) Three dimensional FE analysis of acoustic emission of composite plate, *Journal of KSCM*, 18(5), 15-20
- [10] J. S. Park, K. S. Kim and H. S. Lee (2003) A study on the acoustic emission characteristics of laminated composite structures, *Journal of KSCM*, 16(6), 16.
- [11] L. Dong and J. Mistry (1998) Acoustic emission monitoring of composite cylinder, *Composite Structures*, 40(2), 149-158
- [12] J. C. Choi, J. S. Jung, C. Kim, Y. Choi and J. H. Yoon (2002) A study on the Development of computer-aided Process planning system for the deep drawing & Ironing of high pressure gas cylinder, *Journal of KSPE*, 19(2), 177-186
- [13] Y. Choi, J. H. Yooh, Y. S. Park and J. C. Choi (2004) A study on the Die Design for manufacturing of High Pressure Gas cylinder, *Journal of KSPE*, 21(7), 153-162
- [14] A. Bussiba, M. Kupiec, S. Ifergane, R. Piat and T. Bohlke (2008) Damage evaluation and fracture events sequence in various composites by acoustic emission technique, *Composite Science and Technology*, 68, 1144-1155