

# We are IntechOpen, the world's leading publisher of Open Access books Built by scientists, for scientists

**4,800**

Open access books available

**122,000**

International authors and editors

**135M**

Downloads

Our authors are among the

**154**

Countries delivered to

**TOP 1%**

most cited scientists

**12.2%**

Contributors from top 500 universities



**WEB OF SCIENCE™**

Selection of our books indexed in the Book Citation Index  
in Web of Science™ Core Collection (BKCI)

Interested in publishing with us?  
Contact [book.department@intechopen.com](mailto:book.department@intechopen.com)

Numbers displayed above are based on latest data collected.

For more information visit [www.intechopen.com](http://www.intechopen.com)



---

# Mobile and Wireless Technologies on Sphygmomanometers and Pulsimeters for Patients with Pacemakers and Those with Other Cardiovascular Diseases

---

Ching-Sung Wang and Teng-Wei Wang

Additional information is available at the end of the chapter

<http://dx.doi.org/10.5772/48565>

---

## 1. Introduction

The population with pacemaker implants varies by age, sex or race. Over 100,000 pacemakers are implanted every year in the United States with approximately 500,000 Americans having an implanted permanent pacemaker device [1]. Pacemakers can be affected by electromagnetic interference in several different ways, including temporary inhibition of the pacemaker, temporary function at the fixed noise rate, temporary function at the fixed magnet rate, permanent inhibition or malfunction and random reprogramming. For any of these results to occur, the E field strength must be greater than 200V/m or the magnetic field strength must be greater than 10 Gauss [2].

Mobile tele-medicine is a future development trend. There is much research on it, but most of them discuss GSM, GPRS, 3G, WiMax or LTE. Another key point of mobile tele-medicine is variable electronic medical instrumentation. Our research is expected to integrate embedded system design, wireless communication and medical know-how to implement remote medical care. Long-term blood pressure management is very important for patients who are at risk of stroke or heart attack, therefore, monitoring blood pressure and the ability to immediately call for help are both important. This research will use a portable manometer combined a Bluetooth and GSM cell phone. It can monitor BP and transmit emergency information from wherever people live and wherever they go.

Cellular telephones can interfere with the function of implanted cardiac pacemakers [3,4,5]. However, when telephones are placed over the ear, the normal position, this interference does not pose a health risk [5]. Barbaro V, et al.'s research indicated influence between a

GSM mobile phone and an implanted pacemaker. Electromagnetic interference effects were detected at a maximum distance of 10 cm with the pacemaker programmed at its minimum sensing threshold. When the phone antenna was in direct contact with the patient's skin over the implant, electromagnetic interference effects occurred at the maximum ventricular and atrial sensing thresholds of 4 mV and 2.5 mV, respectively [6]. Therefore, decreasing wireless emission power and increasing pacemaker emission distance are the most useful methods of lowering the magnetic interference to the pacemaker. In order not to affect users' habits of using mobiles and to avoid the electromagnetic interference effects to a pacemaker, we have designed a wristable sphygmomanometer and pulsimeter which uses Bluetooth power class II [7,8] as the device for short-distance transmission. Furthermore, by combining with a cellular phone, we can do prolonged, distant observation and treatment immediately for patients who require adjustments to pacemaker settings or those with other cardiovascular diseases.

## 2. System architecture

This research aims at designing a wristable sphygmomanometer and pulsimeter. We designed a non-invasive sphygmomanometer [9] to remind the user to measure blood pressure every hour. A pulsimeter is an electronic device which is based on a pressure sensor and can observe pulse continuously. In order to avoid the influence of electromagnetic waves on the pacemaker, this research uses the Bluetooth power class II equipment for short-distance wireless data transmission from the sphygmomanometer to the client-end cellular phone, then uses the GPRS (General Packet Radio Service) [10,11] to do the long distance data transmission. This can transmit blood pressure and pulse rate to a Remote Medical Server and then provide them to specialist doctors for reference data.

### 2.1. Client-side hardware architecture

Because of the connecting method of GPRS is a packet switch [10,11], it does not connect with the Remote Medical Server continuously. Therefore, this research utilized a GSM (Global System for Mobile Communications) circuit connection (voice connection) [10,11,12] for the Remote Medical Server to inform the wristable sphygmomanometer and pulsimeter, and to drive the sphygmomanometer to measure blood pressure immediately. Then, the sphygmomanometer will send the results of blood pressure measurements to the Remote Medical Server by GPRS [10,11]. **Figure 1** details the block diagram of the client-side hardware architecture.

### 2.2. Server-side hardware architecture

**Figure 2** details the block diagram of the server-side hardware architecture [13]. Server-side includes a PSTN (Public Switched Telephone Network) phone controller and a monitoring terminal. Furthermore, the PSTN phone controller is constructed by an ATA (Analogue Telephone Adapter), microcontroller and the accessories, which takes the incoming call from the client. W681388 [14] is used as the baseband IC of ATA for ring detection and coding of voice signals. PIC24FJ64 [15] is used as a microcontroller, which receives the

command of the monitoring terminal through the UART interface and controls the W681388 Hook ON/OFF and voice output through the SPI (Serial Peripheral Interface) interface. W681388 is made by Winbond. PIC24FJ64 is made by Microchip.

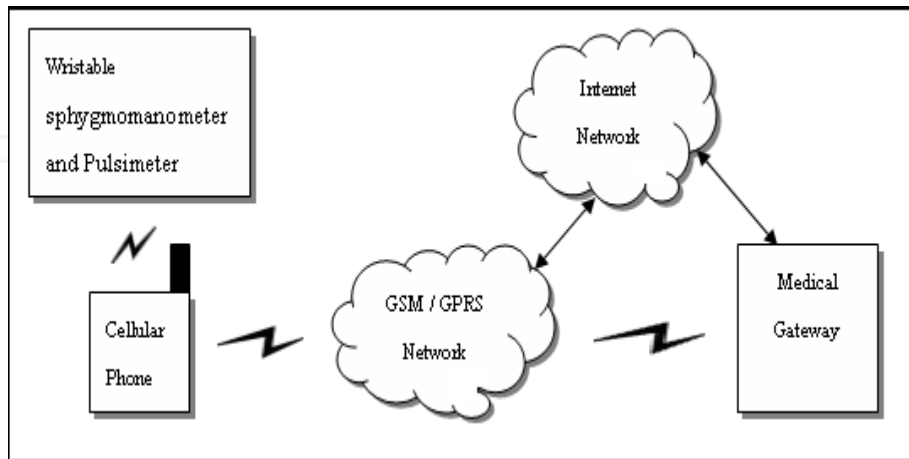


Figure 1. Client-side hardware architecture

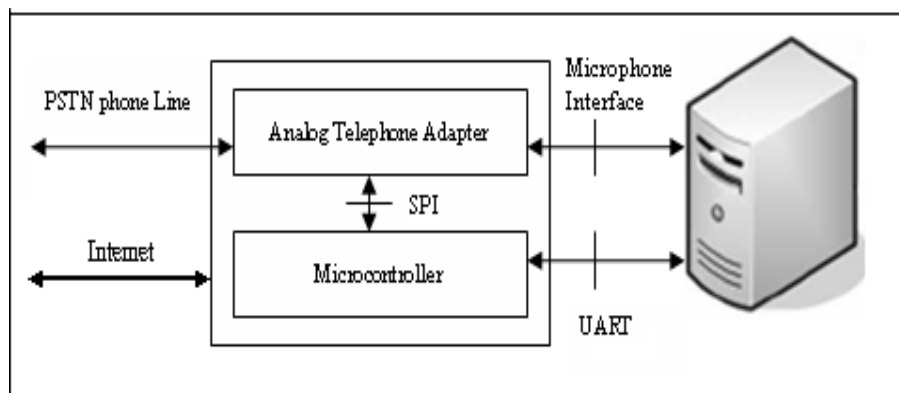


Figure 2. Server-side hardware architecture

### 2.3. Client-end cellular phone hardware architecture

Figure 3 details the block diagram of client-end cellular phone hardware architecture, which includes two main parts, Bluetooth and GSM/GPRS.

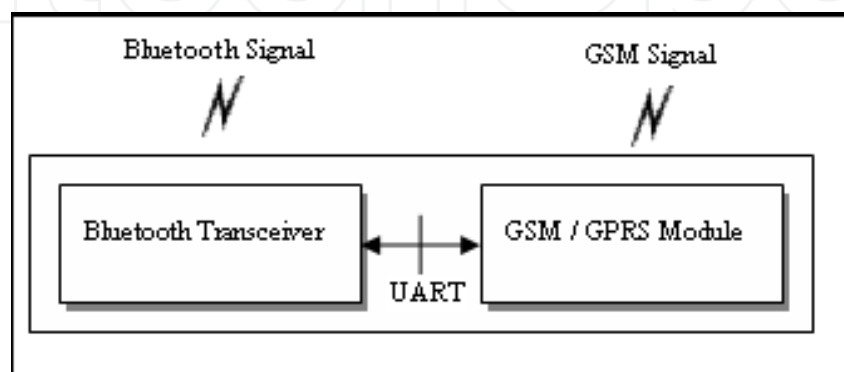


Figure 3. Client-end Cellular Phone Hardware Architecture

1. Bluetooth transceiver [16,17,18]: the hardware framework is similar to the Bluetooth transceiver of wristable sphygmomanometer and pulsimeter. It communicates with GSM/GPRS module by UART interface.
2. GSM Module [18]: includes Baseband part and RF part. The main components are Baseband IC (including DSP), TFT-LCD, NOR Flash, SRAM, Power Management IC and RF IC. We use MT6219 made by MediaTek as the platform for the GSM/GPRS system.

## 2.4. Tele-care system architecture

Figure 4 details the block diagram of the tele-care system architecture. The data is acquired from the wristable sphygmomanometer which transmits to the client-end cellular phone by the Bluetooth device. IMEI (International Mobile Equipment Identity) [19] measure the time and blood pressure data which were transmitted to the server-end cellular phone and all the data are classified, saved then applied.

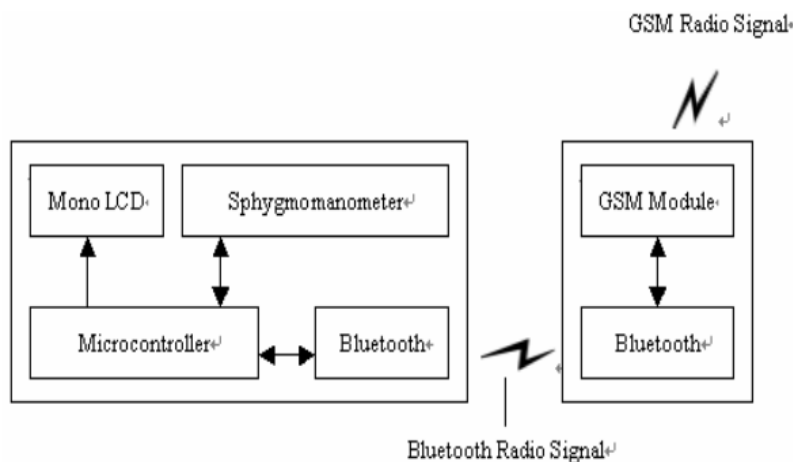


Figure 4. Tele-care system architecture

## 2.5. Tele-emergency announcement system architecture

Figure 5 details the block diagram of the tele-emergency announcement system architecture. When the data exported by the motion sensor is fixed for a period of time, the microcontroller goes into emergency mode. Then the client-end cellular phone establishes a voice connection with the server-end cellular phone. After the connection is established, it transmits IMEI [20], location, time, and blood pressure in DTMF (Dual-tone multi-frequency) format.

## 3. Hardware architecture

The hardware system of this research is divided into two parts, one is a wristable sphygmomanometer and pulsimeter; the other one is a client-end cellular phone. Details are discussed below.

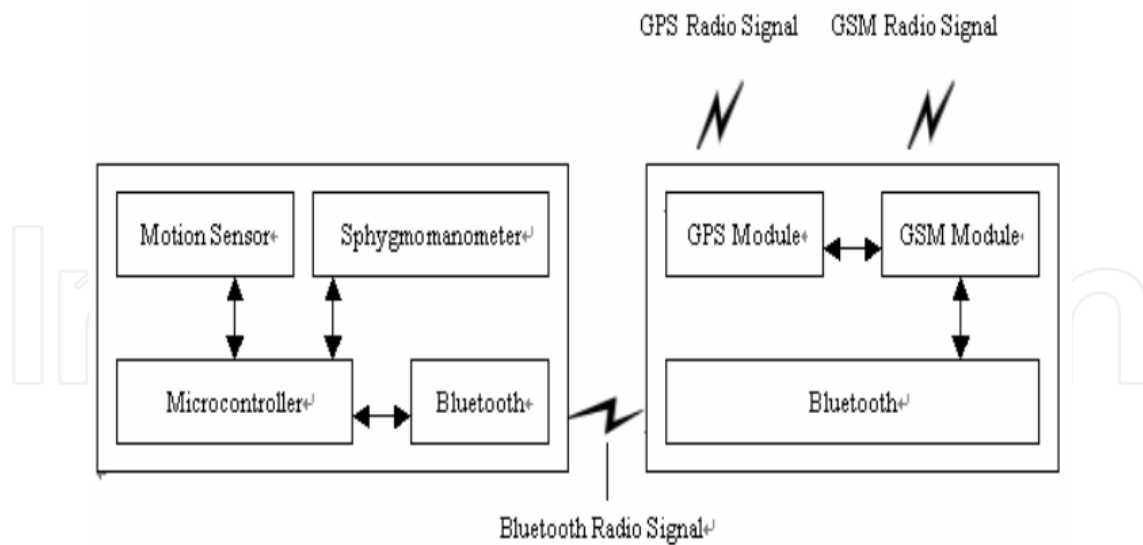


Figure 5. Tele-emergency announcement system architecture

### 3.1. Wristable sphygmomanometer and pulsimeter

Figure 6 details the block diagram of the wristable sphygmomanometer and pulsimeter hardware architecture. The Controller unit of the wristable sphygmomanometer and pulsimeter is the microcontroller [16], which controls and reads the peripheral units. Here is the description of each unit.

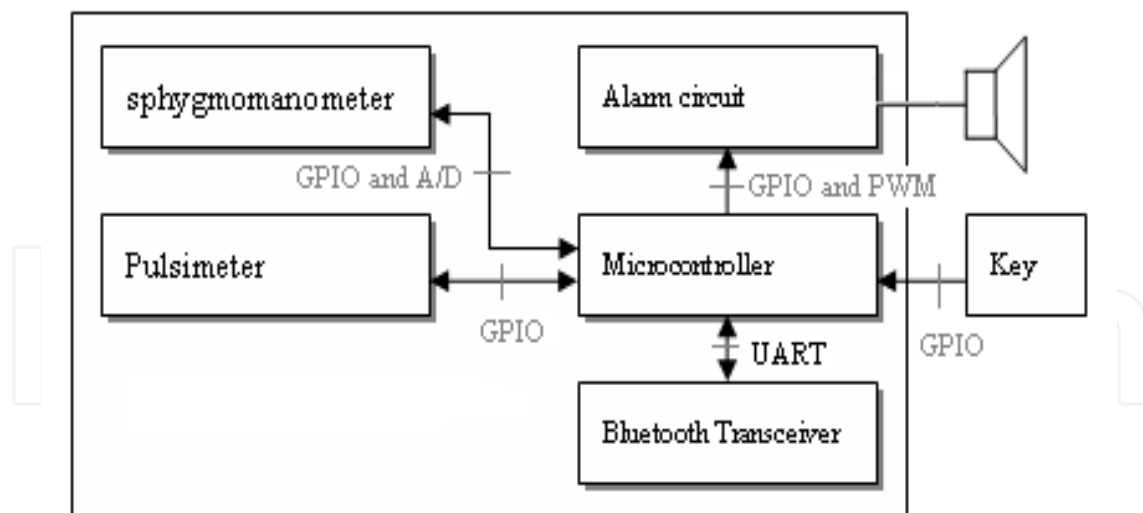
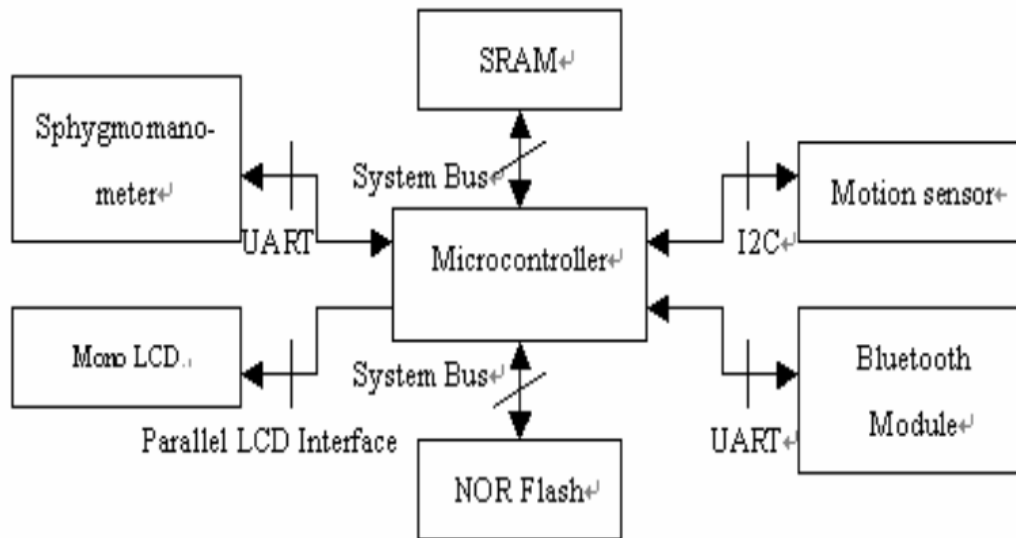


Figure 6. Wristable sphygmomanometer and pulsimeter hardware architecture

1. Sphygmomanometer [9, 16, 17, 18]: Figure 7 details the block diagram of the wristable sphygmomanometer hardware architecture. The wristable sphygmomanometer consists of a 16 bit RISC microcontroller, Bluetooth transceiver, mono LCD, motion sensor and accessories. The microcontroller controls the other components. This is an electronic medical instrument; the microcontroller communicates with the device by the

UART interface of 8051. Bluetooth module [16,18]: the project uses BC3 made by CSR as the Bluetooth transceiver. The microcontroller communicates with the Bluetooth by UART interface and controls all the process by software. Mono LCD[16,21]: mono LCD displays all information in the system. The mono LCD was driven by the microcontroller and communicated to by the parallel LCD interface. Motion sensor [16,22]: we use the MXC6202 chip made by MEMSIC as the motion sensor. It detects the movements of the object and gives all kinds of information for the microcontroller to classify every situation. It uses I2C as the interface.



**Figure 7.** Wristable sphygmomanometer hardware architecture

Details of the sphygmomanometer include the LDO (Low Dropout Regulators) as power controller, pressure sensor, filter, amplifier circuit and accessories. The project is using the pressure sensor of the SCC series which is manufactured by HoneyWell's company. The pressure sensor will transmit different messages according to the changing pressure. The messages pass through the procedures of magnifying (magnify the micro-message from sensor), and filtering (noise removal), and then all the analogue messages are sent to the microcontroller via A/D (Analogue/Digital) interface. **Figure 8** shows the implementation of the sphygmomanometer device architecture.

2. Pulsimeter [9,16,17,18] : the pulsimeter includes LDO, pressure sensor, filter, amplifier circuit and accessories. The circuit is using the SCC series made by HoneyWell, but it has a different sensitivity pressure sensor. Putting the sensor pad over the radial pulse, the pressure sensor will convert the normal pulse to a larger voltage output by magnifying, filtering and then converting (transforming to digital signal), and finally inputs it into the microcontroller. **Figure 9** shows the block diagram of the pulsimeter.
3. Bluetooth transceiver [16, 23]: the project uses BC3 made by CSR as the Bluetooth transceiver. The microcontroller communicates with the Bluetooth by UART (Universal asynchronous receiver/transmitter) interface and controls all the processes using the software.

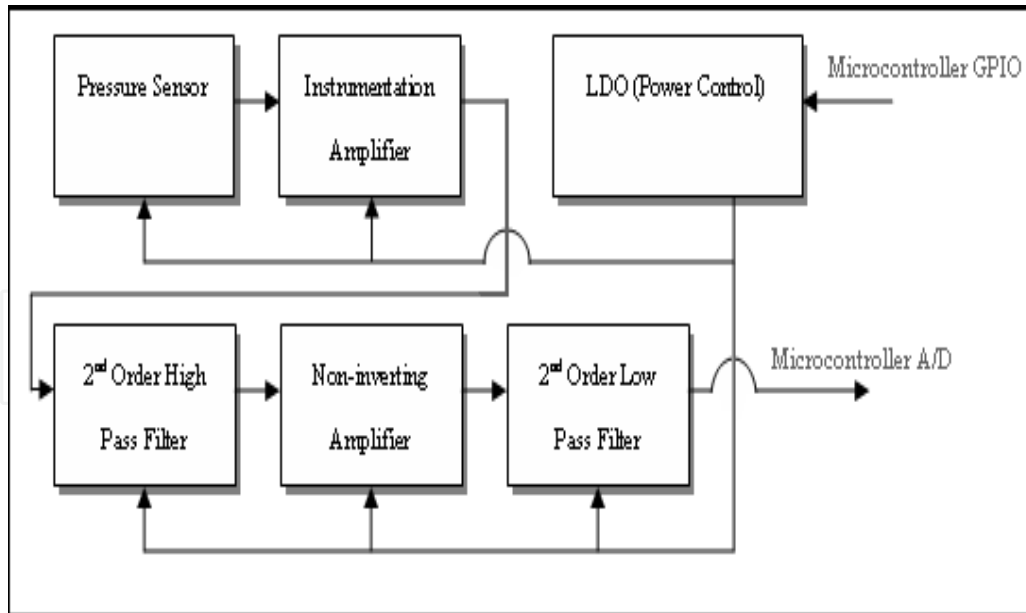


Figure 8. Sphygmomanometer device

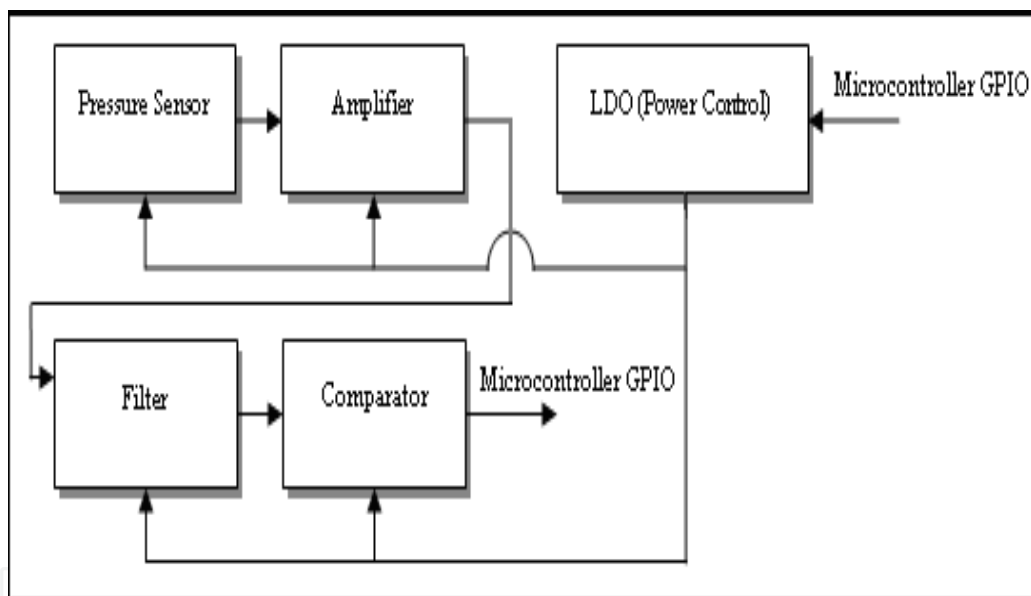


Figure 9. Pulsimeter device

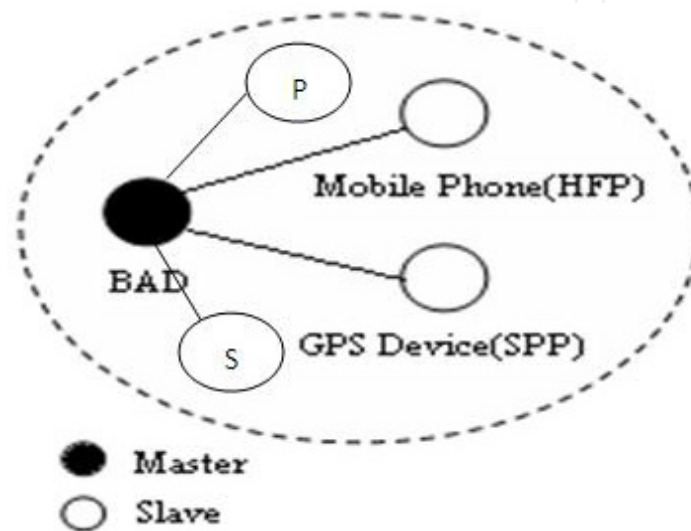
4. Alarm circuit: the main purpose of this part is to send a notice to the users and then to perform blood pressure measurement. The microcontroller can activate the alarm circuit every hour. At the other end, the Remote Medical Server can also order a blood pressure measurement, so that the users can measure their blood pressure when required.

### 3.2. Wireless personal area network base on Bluetooth

Bluetooth provides point to point and multipoint wireless connection according to the Internet concept. Within any active communication scope, all devices are treated the same. The first one requesting communication is called master and the passive one accepting the



signal is called slave. A master and one or more slaves construct the Pico-net of Bluetooth [24], [25]. Because not all mobile phones with Bluetooth function in the current market support Serial Port Profile, the GPS device used in this research cannot connect with all the mobile phones with Bluetooth via the Bluetooth function. In order to cover most mobile phones with Bluetooth in the market in this research and make an active Pico-net, we used the Bluetooth device of BAD (Body Activity Detector) as master, and the Bluetooth devices of the mobile phone and GPS as slave. The Bluetooth of BAD connects with the Bluetooth of the mobile phone and GPS, and forms a PAN (Personal Area Network) upon Bluetooth. **Figure 10** indicates the Bluetooth Pico-net in this system.

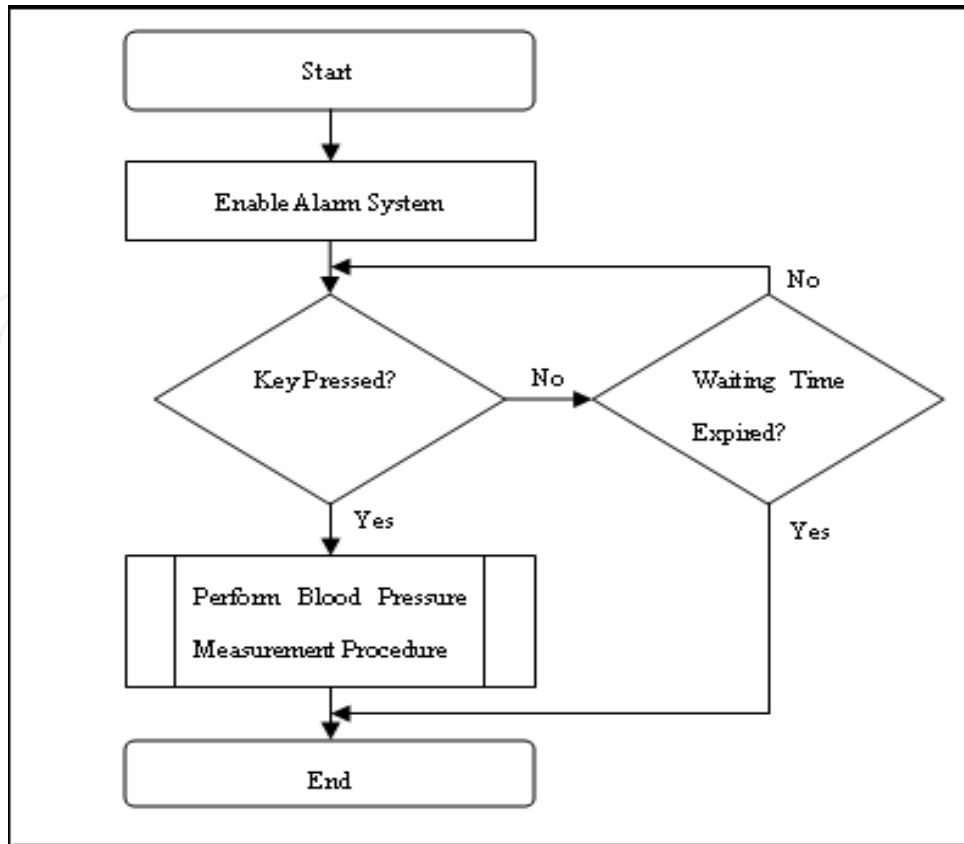


**Figure 10.** Bluetooth Pico-net

## 4. Software algorithm

### 4.1. Continuous pulse and blood pressure measurement, and the monitoring procedure

Pulse monitor procedure [16, 17, 18, 21]: the microcontroller reads the pulsimeter every minute, then transmits the results to the client-end cellular phone by the Bluetooth SPP (Serial Port Profile). Blood pressure measure procedures [9, 16, 17, 18, 21]: the microcontroller enables an alarm system to remind the user every hour to measure blood pressure. Users need to put their hand in the proper position so that the sphygmomanometer can better detect the pulse. When the users put their hand in the proper position and push the trigger button, the microcontroller controls the pulsimeter's LDO to stop the action and start measuring the blood pressure. After that, the microcontroller transmits the blood pressure to the cellular phone by Bluetooth SPP, and activates the pulsimeter. If the user doesn't perform the blood pressure measurement, the microcontroller would re-activate the pulsimeter after a while. The software algorithm of continuous pulse and blood measurement, and the monitoring procedure is shown in **Figure 11** and **Figure 12**.



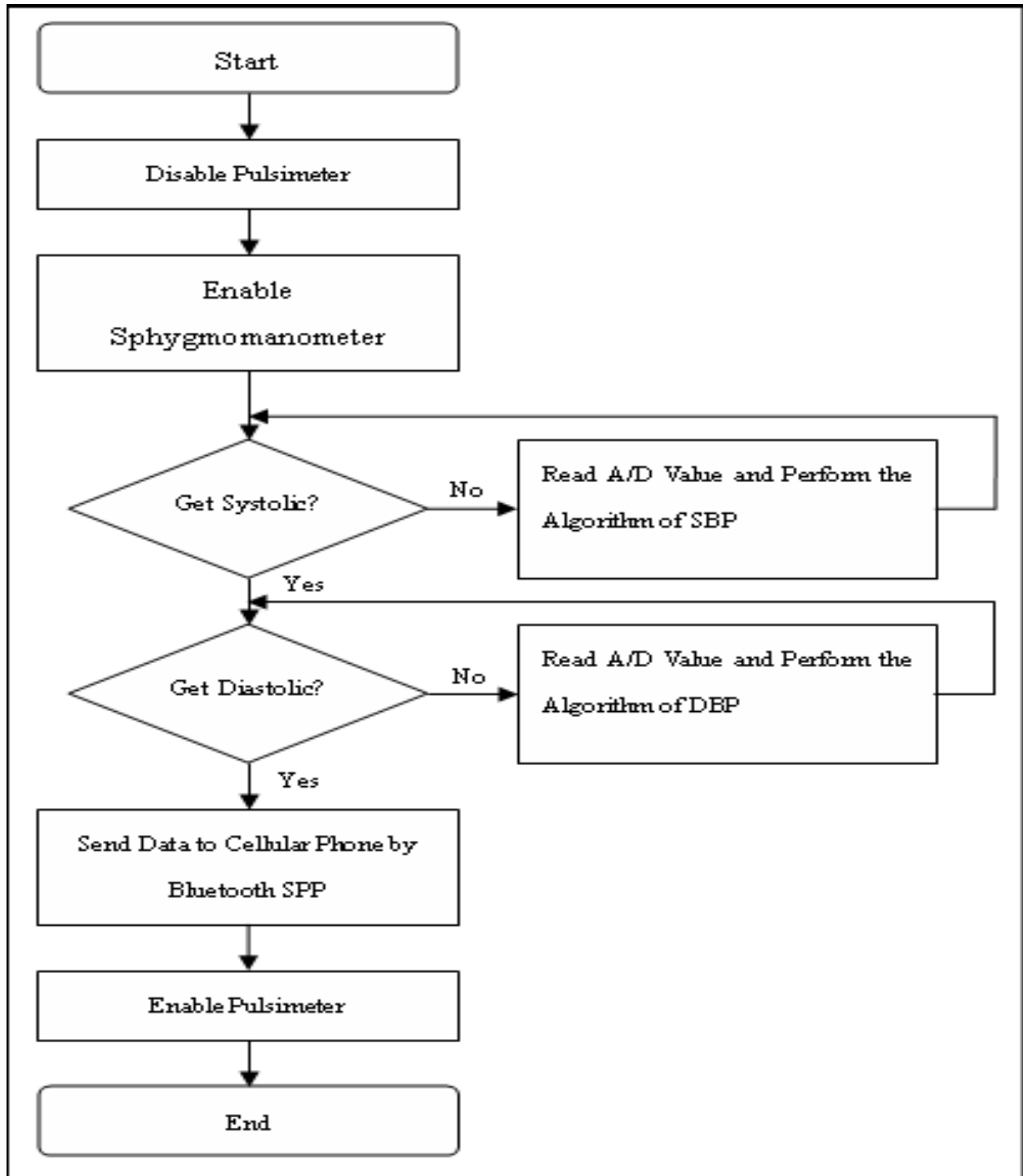
**Figure 11.** The software algorithm of continuous pulse and blood measuring, and the monitoring procedure

#### 4.2. Client-end cellular phone data handling procedure

When the Bluetooth of the mobile receives the data from the Bluetooth of the wristable sphygmomanometer and pulsimeter, it analyses blood pressure or pulse data and stores (including the measurement time) locally first. Finally, it establishes a GPRS connection. After successful connection, the mobile scans the stored blood pressure and pulse data, and then transmits them to the Remote Medical Server if the data has not yet been sent. The software algorithm of the mobile data handling procedure is shown on **Figure 13** [13, 21, 22,25].

#### 4.3. Remote Medical Server claim for measuring blood pressure

If the physician considers that it is necessary to get the patient's current blood pressure immediately, he/she can call the client-end cellular phone using the GSM module on the Remote Medical Server. While the client-end cellular phone receives the incoming call from the server-end, the Bluetooth SPP transmits the command of measuring blood pressure to the wristable sphygmomanometer and pulsimeter. While the wristable sphygmomanometer and pulsimeter receive the command from the Remote Medical Server, they activate blood pressure measurements and transmit procedures. The software algorithm of the Remote Medical Gateway claims for measuring blood pressure are shown in **Figure 14** [13, 21, 22, 25].



**Figure 12.** The software algorithm of the blood pressure measurement procedure

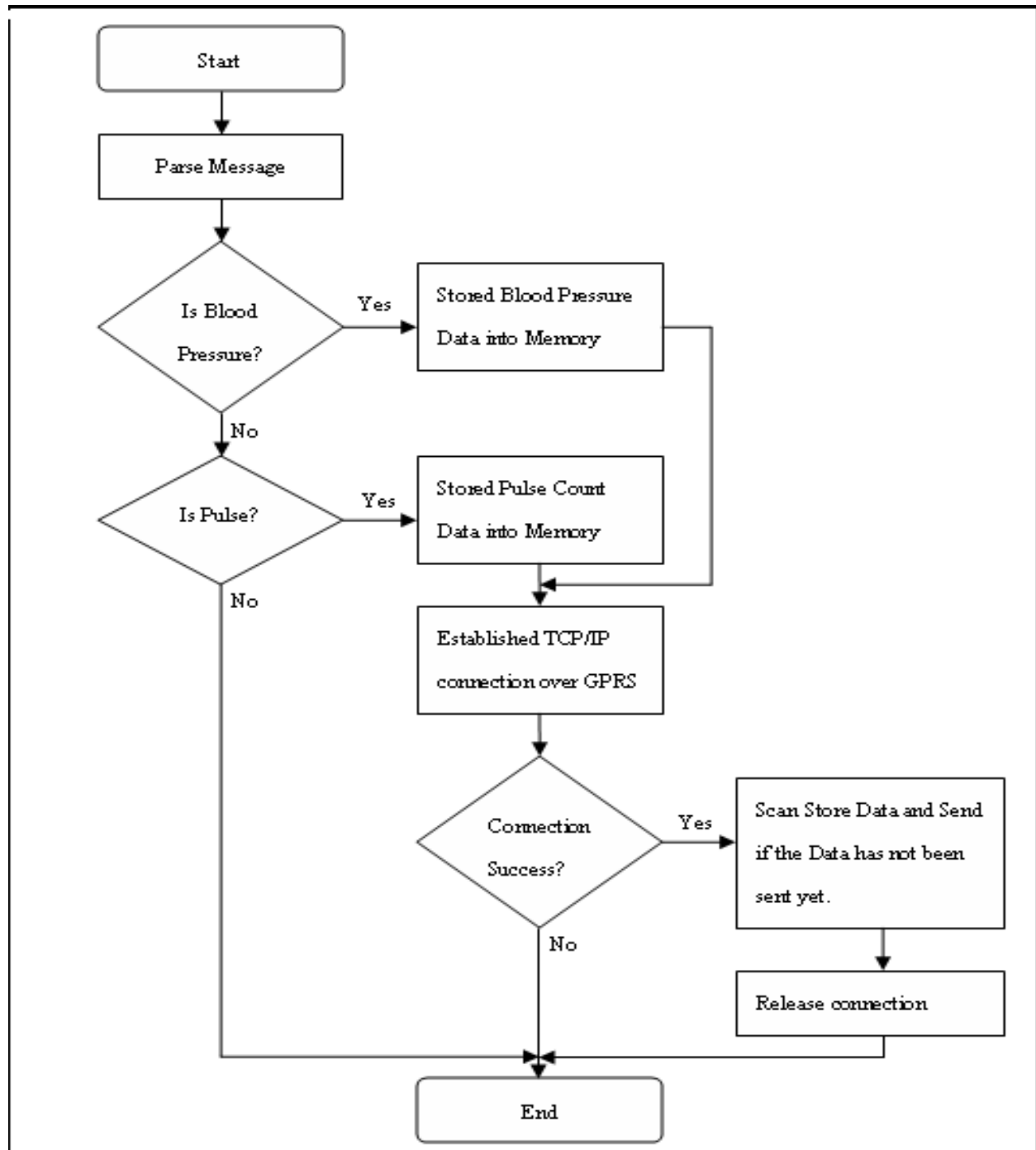
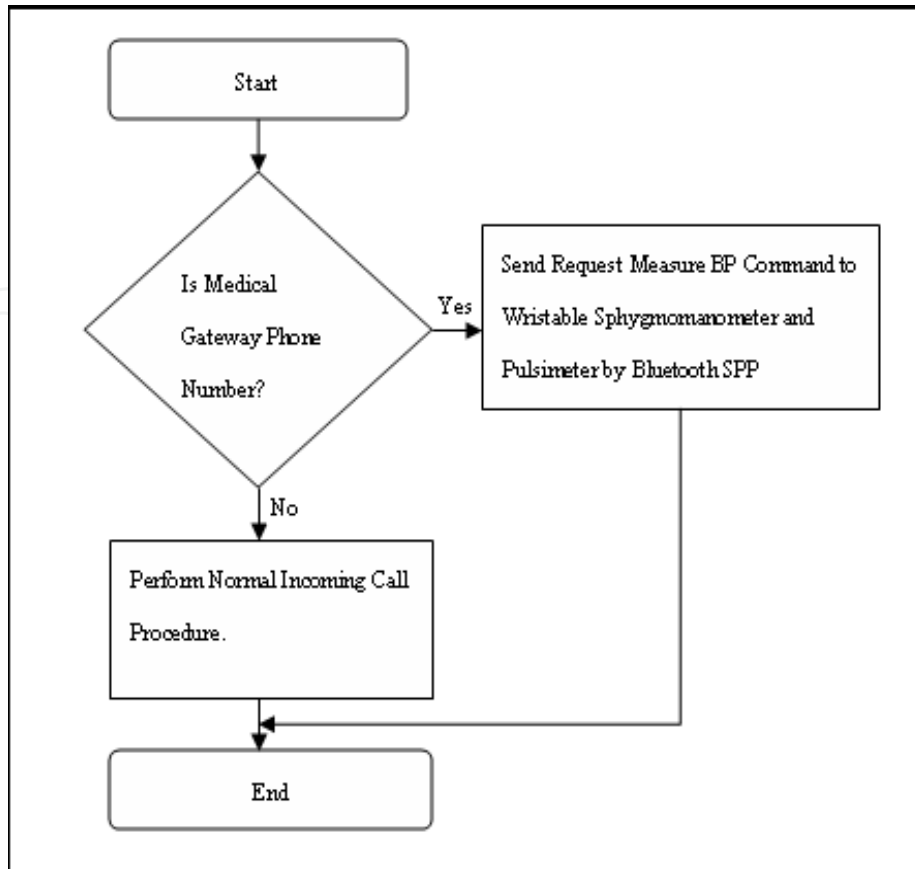


Figure 13. The software algorithm of client-end cellular phone data handling procedure

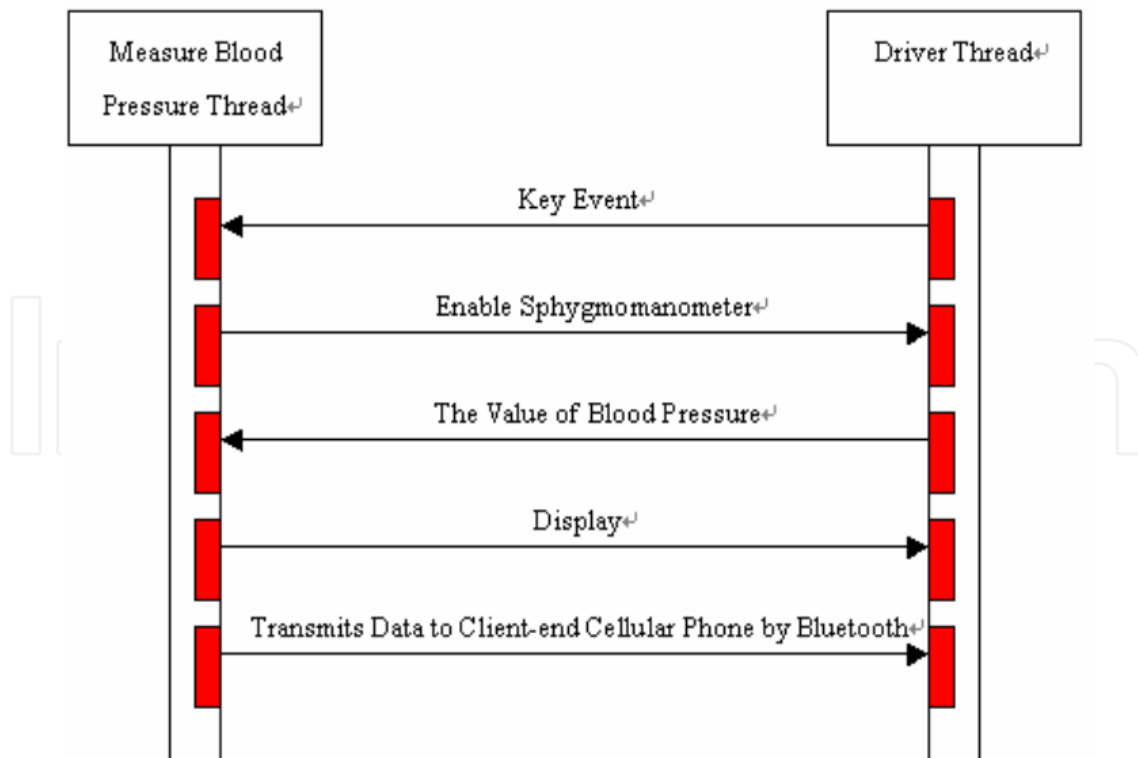


**Figure 14.** The software algorithm of remote medical server claim for measuring blood pressure

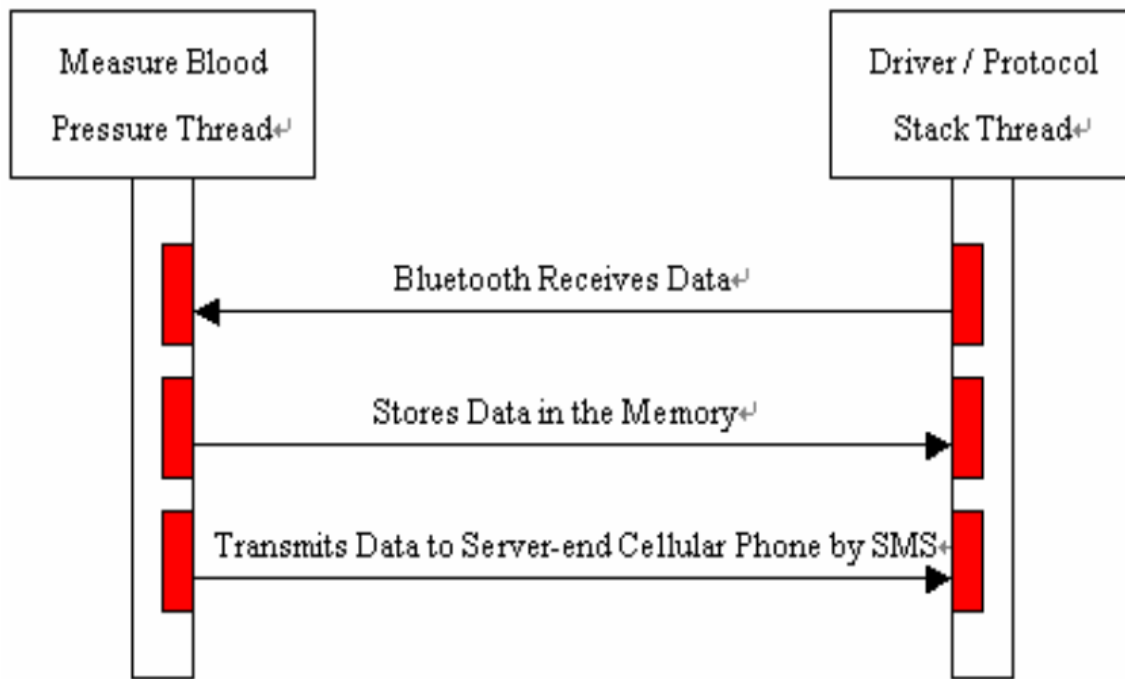
#### 4.4. The whole system operation procedure

1. The procedure of measuring blood pressure by the wristable sphygmomanometer of the tele-care system is shown in **Figure 15** [16,21,27,28,29]. The measurement was triggered by the user. When the microcontroller receives the trigger, it starts the procedure. First, the sphygmomanometer measures the pressure and sends back the data. The data are shown on the mono LCD and transmitted to the client-end cellular phone by Bluetooth SPP (Serial Port Profile).
2. The procedure of measuring blood pressure using the client-end cellular phone of tele-care system is shown in **Figure 16** [20,28,29,30,31,32]. When the Bluetooth of the client-end cellular phone receives signals, it checks the format and the Checksum of the data. The data is saved and sent to the sever-end cellular phone by Send Message over SD (Circuit Switched Data) if it is correct.
3. The procedure of measuring blood pressure using the server-end cellular phone of tele-care system is shown in **Figure 17** [19,20,29,30,31]. When the server-end cellular phone receives a short message from the client-end cellular phone, it checks the format and the Checksum of the data. If it is correct, the short message is decoded and saved according to IMEI. Then the message is erased.
4. The emergency procedure of the wristable sphygmomanometer of the tele-emergency announcement system is shown in **Figure 18** [16,27,28,32]. The microcontroller reads the

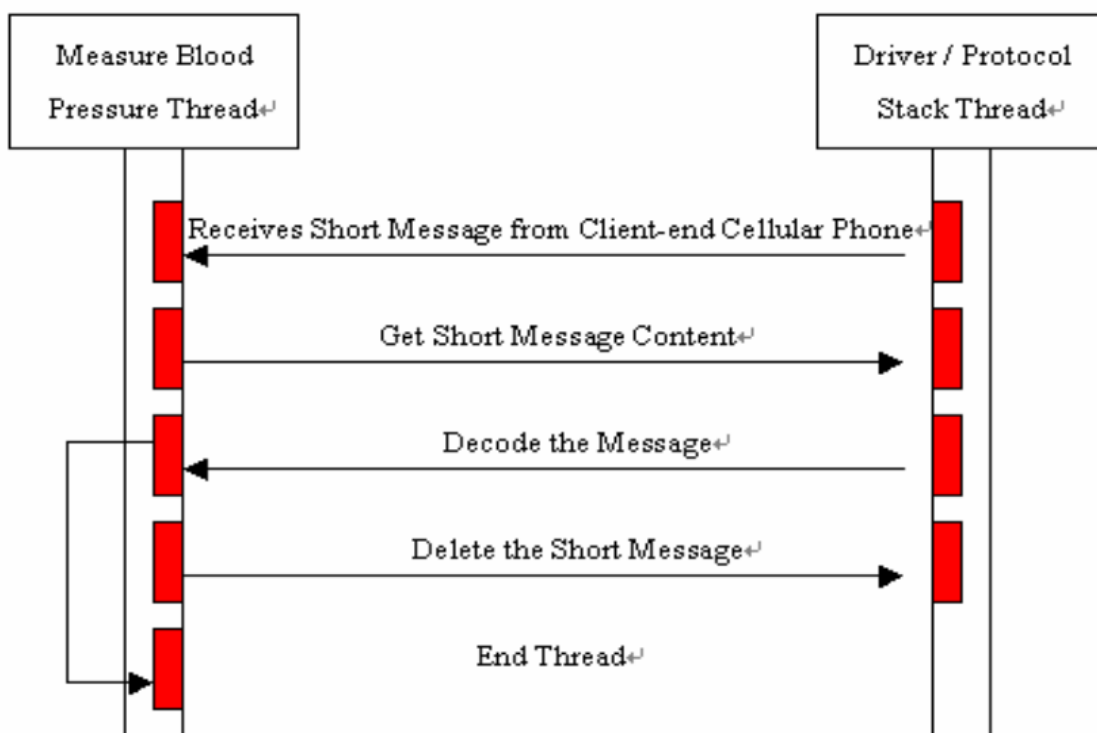
- data which was acquired from the motion sensor every second. If the data repeats 30 times, it is called the Emergency Task and Alarm. If the user pushes the button, the Emergency Task will stop. Otherwise it will trigger sphygmomanometer measuring. The microcontroller sends an emergency message to the client-end cellular phone by Bluetooth SPP, once the number which is received from the sphygmomanometer measurement is defined as dangerous.
5. The procedure of emergency of the client-end cellular phone of tele-emergency announcement system is shown in **Figure 19** [19,20,28,29,30,31,32]. When the Bluetooth of the client-end receives signals, it checks the format and the Checksum of the data. If it shows an emergency message, it is called the Emergency Task. In order to transmit a clear DTMF tone, the phone closes the microphone and forces the system to send out a Caller ID. Then the client-end cellular phone establishes voice connection with the server-end cellular phone. After the connection is established, it transmits IMEI, location, time and blood pressure in DTMF format.
  6. The procedure of emergency of the server-end cellular phone of tele-emergency announcement system is shown in **Figure 20** [19,20,29,30,31]. When the server-end mobile receives the incoming call from the client-end mobile phone, it will be forced to connect, and turn off the microphone, then switch audio path to the DTMF decoder [33]. After 2 seconds, if the controller receives the correct format and Checksum from the DTMF decoder, the phone will make a specific tone at the loudest setting, start the vibrator, then an emergency message will show on the display. It won't stop the tone and vibrator, even if it is disconnected.



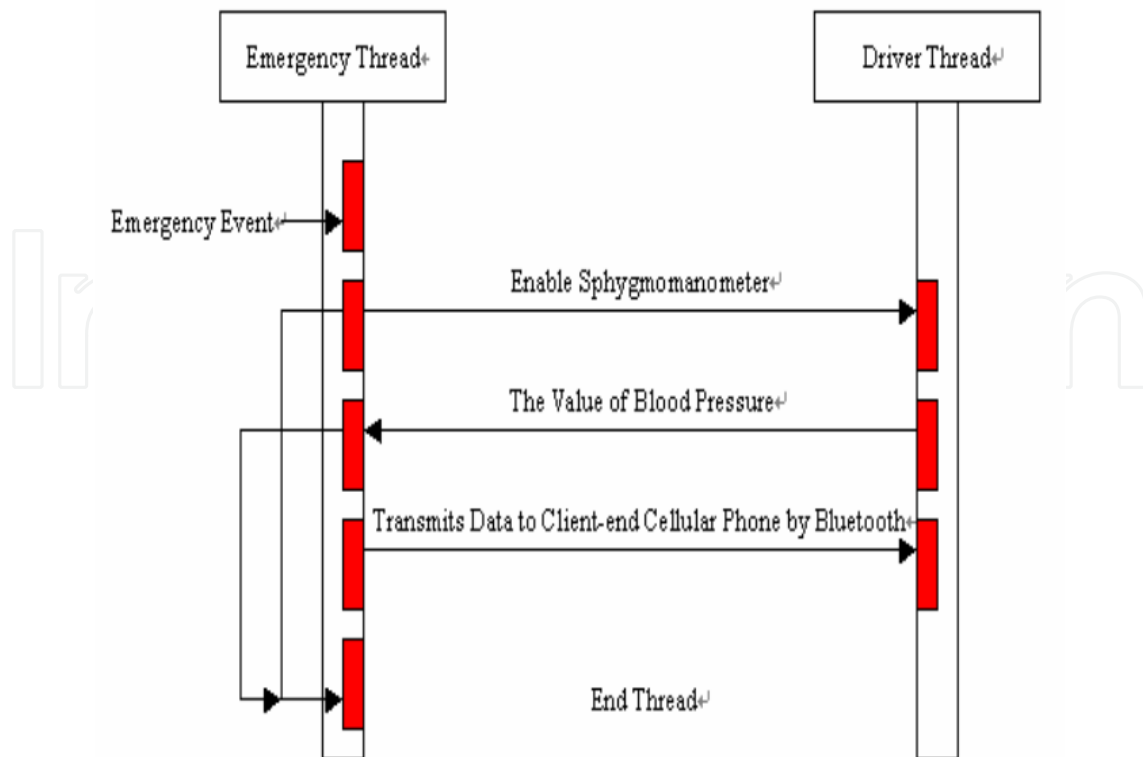
**Figure 15.** Procedure of measuring blood pressure by the wristable sphygmomanometer of the tele-care system



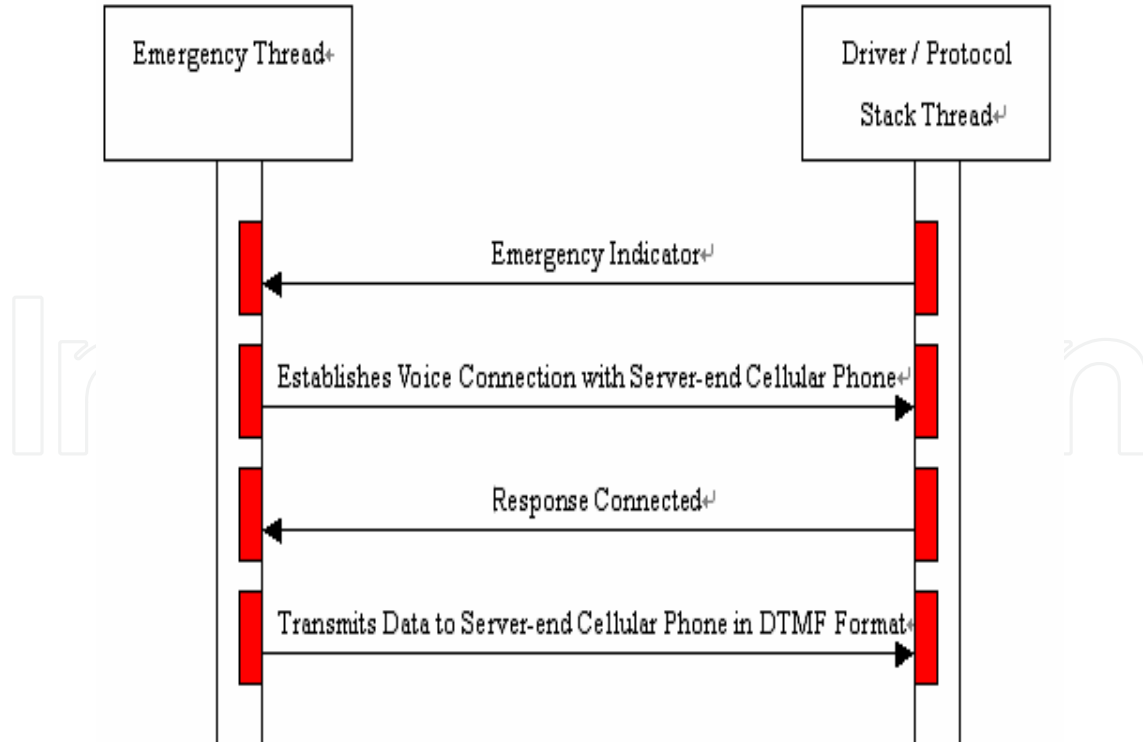
**Figure 16.** Procedure of measuring blood pressure using the client-end cellular phone of the tele-care system



**Figure 17.** Procedure of measuring blood pressure of the server-end cellular phone of tele-care system

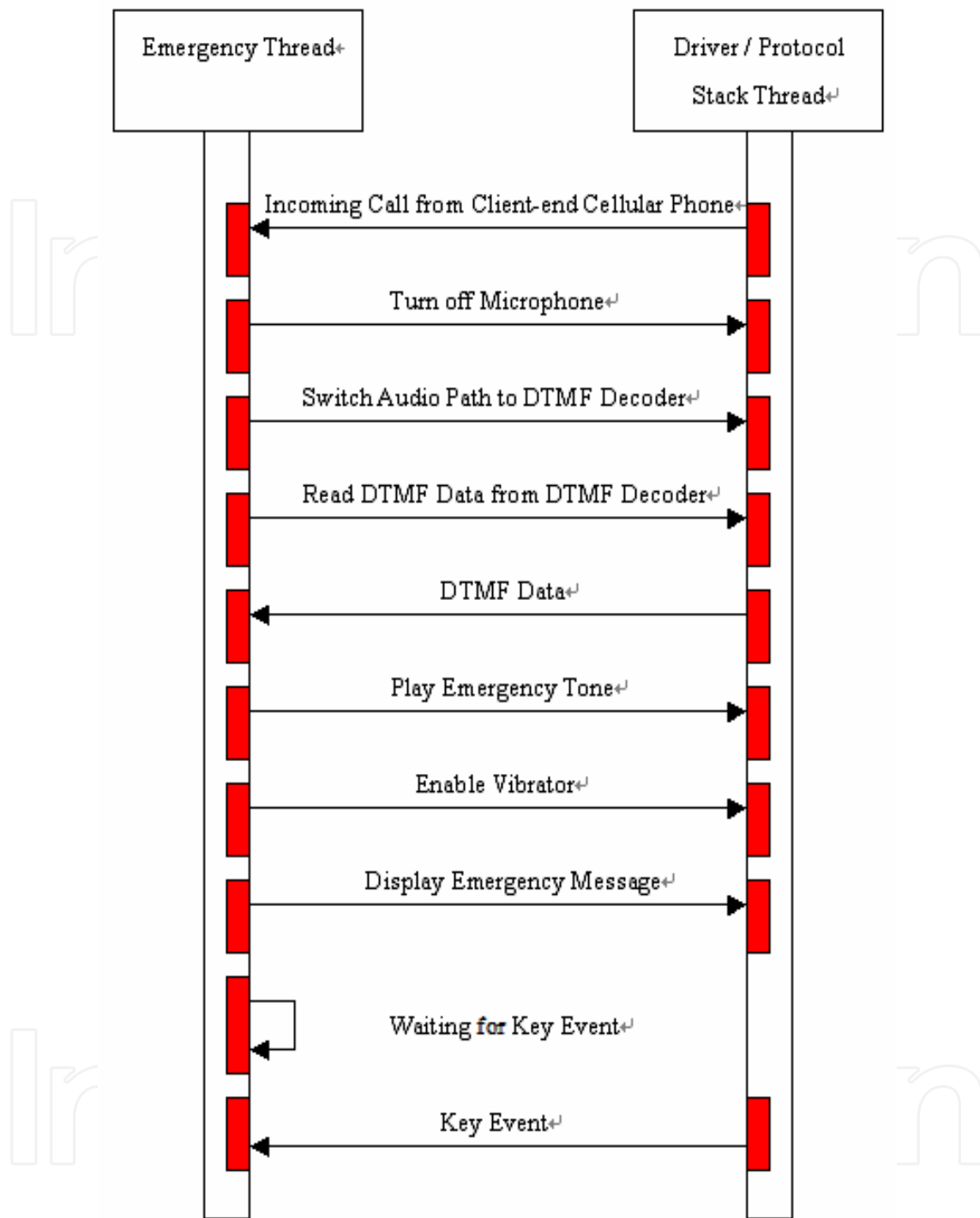


**Figure 18.** Emergency procedure of the wristable sphygmomanometer of the tele-emergency announcement



**Figure 19.** Emergency procedure of the wristable sphygmomanometer of the tele-emergency announcement system



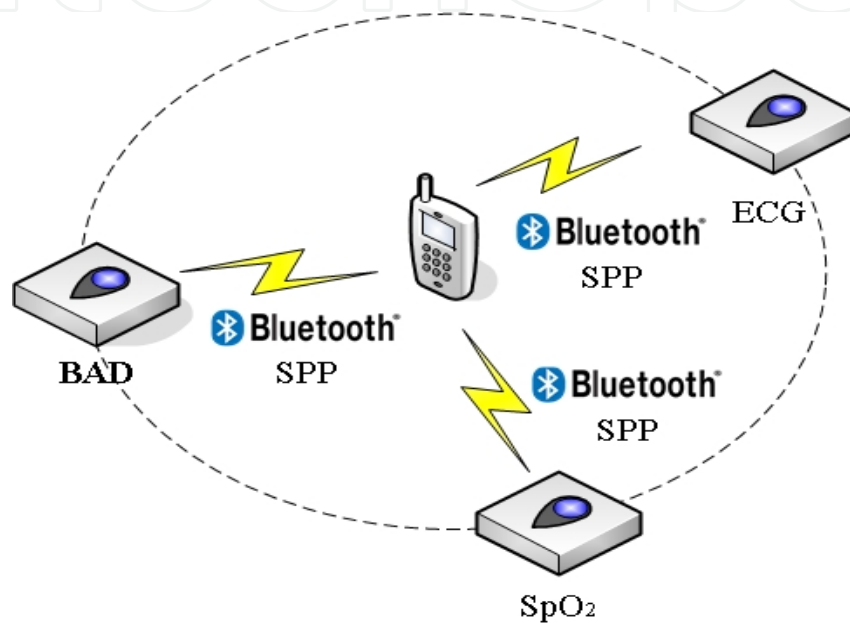


**Figure 20.** Emergency procedure of the server-end cellular phone of tele-emergency announcement system

### 5. Remote monitoring measurement example

We conducted an experiment using SpO2 and ECG using the GPS device and the 3G system of an Android smart phone to form a remote monitoring system, which can be used in the daily care of patients with implanted pacemakers.

This system is categorized into three main structures, client, server and first aid unit. The client includes BAD, a biomedical signal monitoring device (including ECG and SpO<sub>2</sub> monitoring devices) and an Android mobile phone with Bluetooth communication ability. When BAD detects an abnormal health response from the user, it will give the mobile a report by means of the Bluetooth. In the meantime, the operating biomedical device, with sending signals back, allows GPS coordination to take place. These messages would be sent back to the server through the mobile phone's Internet system. The server-end is predominantly used to save the data, to analyse it and to communicate with others as shown in Figure 21.



**Figure 21.** Bluetooth Pico-net

### 5.1. System communication

**Figure 22** is the system communication plot. BAD, ECG and SpO<sub>2</sub> will shut down the system into their power save mode after Bluetooth and cell phone pairing. When the BAD detects an emergency, it will resume normal power and contact the cell phone to call out ECG and SpO<sub>2</sub> processing.

### 5.2. Emergency procedure

After receiving a BAD emergency signal, the system will enter the emergency procedure mode as shown in **Figure 23**. First it will check the signal again. If it is still an emergency signal, it will start the GPS to find out where the user is and identify whether the target moves. If the target stays put, it will start ECG and SpO<sub>2</sub> Bluetooth devices. After receiving the data, it activates the cell phone monitoring and displaying, and alerts nearby people for further assistance. At the same time, the data is sent back to the server and informs First Aid Units of the need for further help. **Figure 24** shows the biomedical signals of ECG and SpO<sub>2</sub> on the Android smart phone.

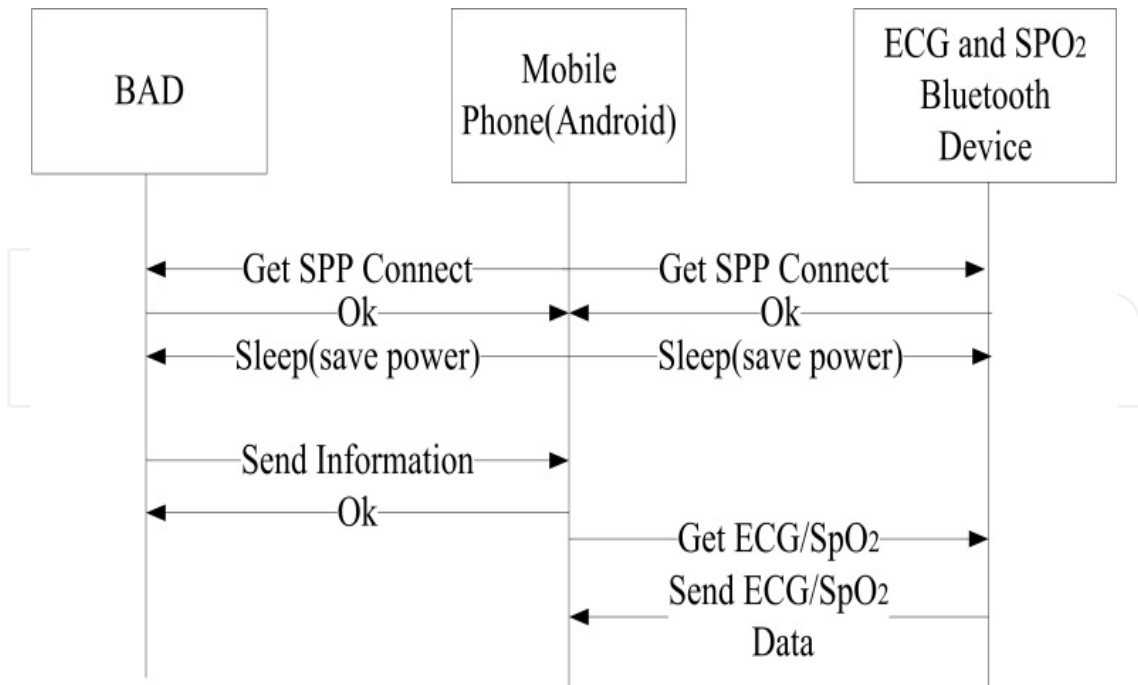


Figure 22. System communication

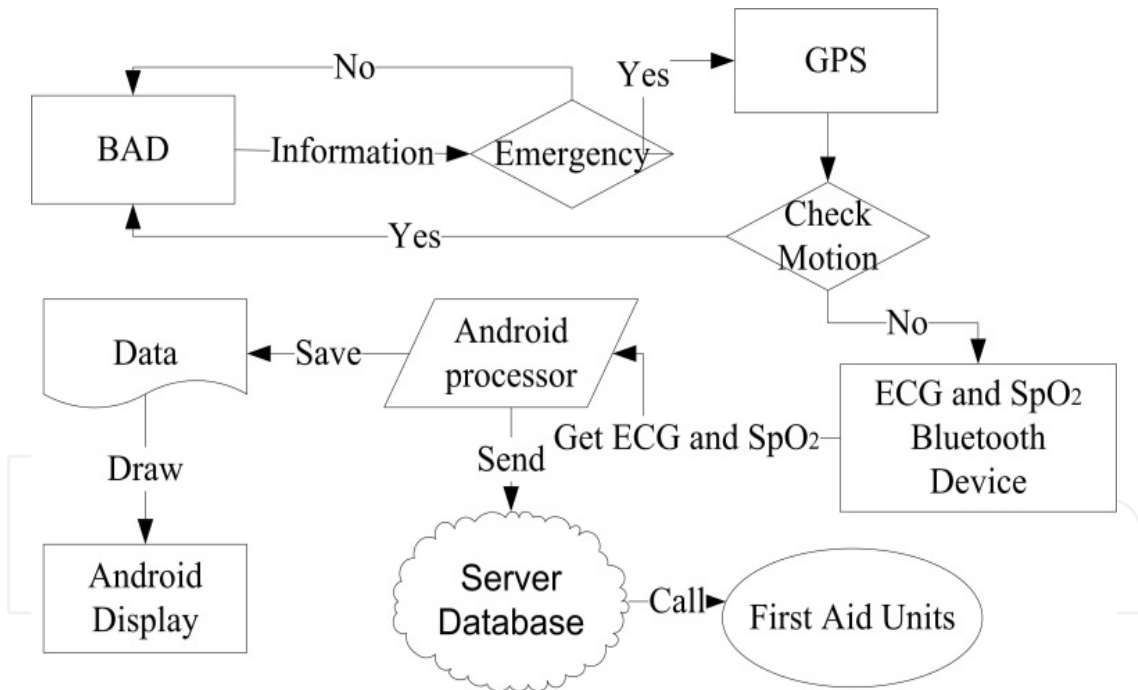


Figure 23. Emergency procedure

### 5.3. Web-end

The remote monitoring personnel confirm the biomedical information through the WEB interface, such as the ECG shown in **Figure 25**, and receive the signal when the patient needs help. At the same time, it uses GPS to confirm the client position to assist the ambulance to arrive at the right place (see **Figure 26**).



Figure 24. The biomedical signals ECG and SpO<sub>2</sub> on the Android smart phone



Figure 25. Server Web-end

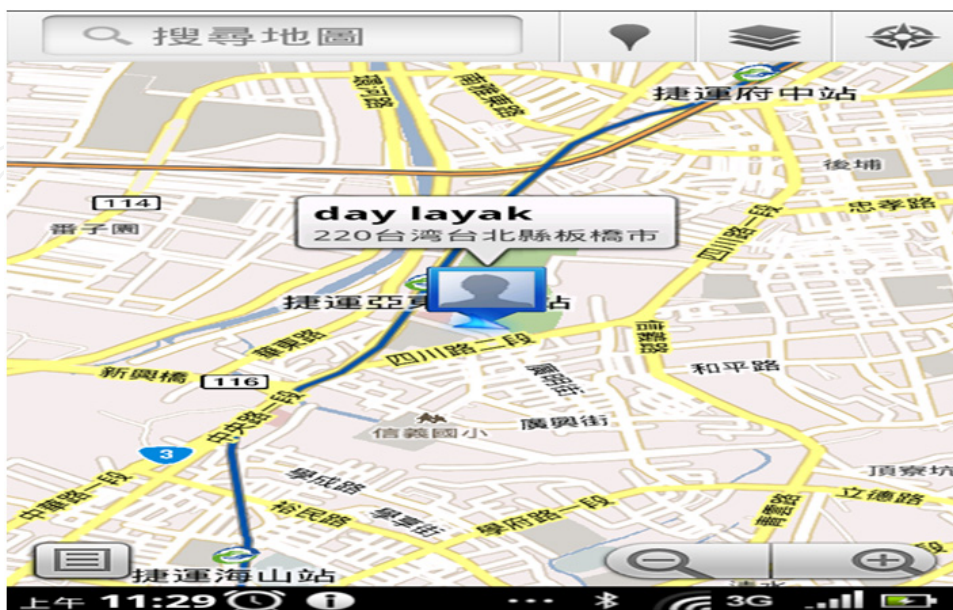


Figure 26. GPS location

## 6. Conclusion

It may be dangerous to have continuously operating mobile connection close to the heart for patients with artificial pacemakers as it may consider the electromagnetic wave from the mobile to be a cardiac signal, leading to oversensing. However, frequent pulse and blood pressure measurement may be necessary for certain patient groups, such as those with high arrhythmia risk, hypertension, coronary artery disease or heart failure. As Bluetooth technology is safe to use in proximity of pacemakers, we have designed a portable medium based on the Bluetooth power class II RF test specification. We expect that this system will benefit these patients without causing inconvenience to their daily activities or risking adverse interaction with the pacemaker.

## Author details

Ching-Sung Wang

*Department of Electronic Engineering, Oriental Institute of Technology, Taipei, Taiwan*

Teng-Wei Wang

*The Third Department of Clinical Research Institute, Peking University, Peking, China*

## 7. References

- [1] <http://www.surgeryencyclopedia.com/La-Pa/Pacemakers.html>
- [2] Tacey S, Ronald A, "The Effects of Electromagnetic Fields on Cardiac Pacemakers" IEEE Transactions on Broadcasting, Vol.38, No.2, June 1992
- [3] Barbaro V, Bartolini P, Donato A, et al. "Do European GSM mobile cellular phones pose a potential risk to pacemaker patients?" PACE 1995; 18: 1218-24
- [4] Okan Erdogan, MD, "Electromagnetic Interference on Pacemakers", Indian Pacing Electrophysiol J. 2002 Jul-Sep; 2(3): 74-78
- [5] Hayes DL, Wang PJ, Reynolds DW, et al. "Interference with cardiac pacemakers by cellular telephones". N Eng J Med 1997; 336: 1473-9
- [6] Bluetooth, Specification of the Bluetooth System Core, Version 2.0, 2004
- [7] Bluetooth, Radio Frequency Test Suite Structure (TSS) and Test Purposes (TP) Specification 1.2, Revision 1.2.3, 2004-08-24
- [8] Nissila, S, Sorvisto, M, Sorvoja, H, Vieri-Gashi, E, Myllyla, R, "Non-invasive blood pressure measurement based on the electronic palpation method", Engineering in Medicine and Biology Society, 1998. Proceedings of the 20th Annual International Conference of the IEEE, Volume 4, 29 Oct.-1 Nov. 1998 Page(s):1723 - 1726 vol.4
- [9] Yi-Bing Lin, Imrich Chlamtac, "Wireless and Mobile Network Architectures", Wiley Computer Publishing, 1 edition (October 2, 2000)
- [10] Mouly, M, Pautet, M-B, "The GSM System for Mobile Communications", Telecom Publishing (June 1992)

- [11] Ching-Sung Wang, Jung-Hunag Lee, Yiu-Tong Chu, "Mobile Telemedicine Application and Technologies on GSM", Bioinformatics and Biomedical Engineering, 2007. ICBBE 2007. The 1st International Conference on 6-8 July 2007 Page(s):1125 – 1128
- [12] MediaTek "AT Command Set", Revision: 0.03, Sep. 1. 2004
- [13] Ching-Sung Wang, Chien-Wei Liu, Teng-Wei Wang, "Tele-care for emergency announcements" Journal of Biomedical Science and Engineering, pp.822-827, Aug.,2010
- [14] Winbond Inc., "W681388 Single Programmable Extended CODEC/SLIC", ver1.0, 2006.
- [15] Microchip Inc., "PIC24FJ64GA004 Family Data Sheet", 2007.
- [16] National Semiconductor "SC14440/431/432, SC14435, SC14436/437/438. Baseband Processor for PP/FP DECT and WDCT", V1.1, June 16, 2005
- [17] Champion "CM2838, 300mA Low ESR CMOS LDO With Enable", Rev 1.1, 2004/0501
- [18] HoneyWell, "SSC Series Pressure Sensors 0 – 5 psi Through 0 – 300 psi" , 2002
- [19] ETSI "Digital cellular telecommunications system (Phase 2+); International Mobile station Equipment Identities (IMEI); (GSM 02.16 version 6.2.0 Release 1997)", 2000-07
- [20] ETSI "Digital cellular telecommunications system (Phase 2+); Technical realization of the Short Message Service (SMS); (GSM 03.40 version 7.4.0 Release 1998)", 1999-12
- [21] ELAN "EM62100 65 COM/ 132 SEG STN LCD Driver Product Specification", version 1.5, September 2006
- [22] MEMSIC "MXC6202xJ/K Data Sheet", Rev A, 2006
- [23] CSR, "BlueCore3-ROM CSP Product Data Book", Nov 2006
- [24] Specification of the Bluetooth System Core, Version 2.0, 2004
- [25] Pravin Bhagwat Reefedge Inc., "Bluetooth: technology for short-range wireless apps", IEEE Internet Computing, Volume 5, Issue 3, May-June 2001 Page(s): 96 – 103.
- [26] MediaTek "MT6219 GSM/GPRS Baseband Processor Data Sheet", Revision 1.00, Feb 02, 2004.
- [27] ATMEL "AT89C2051 8-bit Microcontroller with 2K Bytes Flash Data Sheet", 6/05.
- [28] Bluetooth SIG, "Specification of the Bluetooth System Profile, Part K:5 Serial Port Profile", version 1.1, 2001
- [29] MediaTek "Customer Device Driver Document", Revision: 0.1, Nov 03, 2003
- [30] PixTel "Writing Applications Using PixTel MMI Platform", version: 1.3, July 10, 2004
- [31] ETSI "Digital cellular telecommunications system (Phase 2+); AT command set for GSM Mobile Equipment(ME);(GSM 07.07 version5.9.1 Release 1996)", December 1999

[32] Bluetooth SIG, Specification of the Bluetooth System Core, version 2.0, 2004

[33] MITEL "MT8870D/MT8870D-1 Data Sheet", May 1995

IntechOpen

IntechOpen