

We are IntechOpen, the world's leading publisher of Open Access books Built by scientists, for scientists

4,800

Open access books available

122,000

International authors and editors

135M

Downloads

Our authors are among the

154

Countries delivered to

TOP 1%

most cited scientists

12.2%

Contributors from top 500 universities



WEB OF SCIENCE™

Selection of our books indexed in the Book Citation Index
in Web of Science™ Core Collection (BKCI)

Interested in publishing with us?
Contact book.department@intechopen.com

Numbers displayed above are based on latest data collected.

For more information visit www.intechopen.com



Evolution and Expectations of Enzymatic Biosensors for Pesticides

Rafael Vargas-Bernal, Esmeralda Rodríguez-Miranda and Gabriel Herrera-Pérez

Additional information is available at the end of the chapter

<http://dx.doi.org/10.5772/46227>

1. Introduction

The successful use of pesticides around the world has been due to their excellent control of pests such as insects, algae, bacteria, viruses, rodents, or nematodes in agriculture, medicine, household, and industry. Since 9 of the 12 most dangerous and persistent organic pollutants are pesticides, therefore their qualitative and/or quantitative detection continue being one of the most strategic technological areas, given that these can be found in substances in contact with humans and other animals. The effects associated with their consumption and control, are related to human health and environmental toxicity. One of the most important contributions of the environmental chemistry is the control of pesticide residues and metabolites in food, water and soil; where plants, animal and human contacts are possible. Several methods to detect pesticides have been developed, chromatographic methods such as gas chromatography (GC) and high performance liquid chromatography (HPLC), which are coupled with mass spectrometry (MS). Although, these methods are very sensitive and reliable, they are very complex. In addition, they consume a lot of time to realize the analysis, require highly trained technicians for their use, and do not allow on-site or in-field detection. Biosensors represent an interesting technological alternative to determine the presence qualitative and quantitative of pesticides. Their operation is based through a self-contained integrated device including all subsystems required to realize the measurement and transfer of results in an electronic manner. They are a solution of low-cost, fast, high portability, and they do not require trained technicians to be used. In specific, both electrochemical as optical biosensors for pesticides, that use the enzyme immobilization by means of catalytic activity, will be studied with the aim of visualizing their evolution, advances, and perspectives in the near future. Finally, it is illustrated that research in this area might be directed with the aim of optimizing the performance desired.

This chapter is divided as follows: In Section 2, basic concepts related with pesticides and enzymes are described. Next, the history of the enzymatic pesticide biosensors is analyzed

with the aim of identifying the contributions realized in this area, in Section 3. In Sections 4 and 5, the contributions of the optical and electrochemical biosensors in the detection of pesticides in the last years are discussed, respectively. Future perspectives and advances associated with enzymatic pesticide biosensors are described in Section 6. Finally, in Section 7, conclusions highlighting the importance of the study realized here are given.

2. Basic concepts about pesticides and enzymes

A pesticide is any substance or mixture of substances used to prevent, destroy, repel or mitigate any pest. In United States of America, a pesticide can also be used as a plant regulator, defoliant, or disinfectant. Different substances can be used as pesticides: chemical, biological agent, antimicrobial or disinfectant. A pest is a living organism that appears where it is not wanted or that causes damage to crops, animals, or humans. Among the pests can be found: insects, plant pathogens, weeds, mollusks, birds, mammals (rodents), fishes, nematodes, and microbes. Pesticides are categorized in accordance with their chemical substituents: herbicides, fungicides, insecticides and bactericides, as shown in Figure 1. An herbicide is a pesticide used to kill unwanted plants or to reduce the growth of the weed, which leaves unperceived secondary effects. These pesticides are used in different tasks such as forestry, pasture, control of wildlife habitats, and cleaning of waste grounds, industrial sites, railways and railway embankments. A fungicide is a pesticide used to kill or inhibit fungi and fungal spores, which damages the quantity, quality and profit of yield. Such pesticides are used in agriculture and livestock to fight against fungal infections. An insecticide is a class of pesticide used against insects in all stages of growth: egg, larva, and insect. Almost all insecticides modify the ecosystem where they are used; a lot of them are toxic for humans; and much of them are involved in the food chain. A bactericide is a pesticide that kills bacteria. This class of pesticide is used as disinfectant, antiseptic or antibiotic.

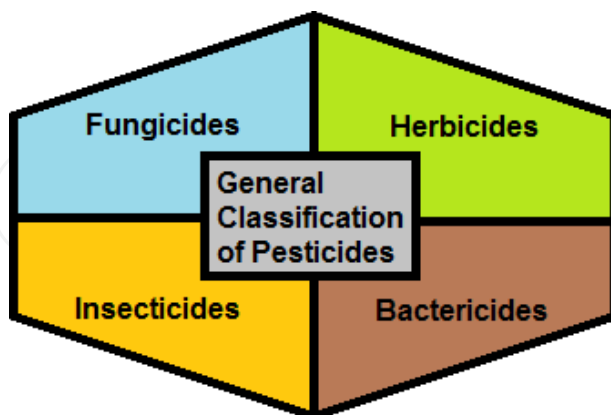

Figure 1. General classification of pesticides by chemical substituents.

The main types of pesticides are illustrated in Figure 2. Among the main pesticides that have been or can be detected are organophosphates (acephate, azinphos-methyl, bensulide, chlorethoxyfos, chlorfenvinphos, chlorpyrifos, chlorpyrifos-methyl, coumaphos, demeton-S-methyl, diazinon, dicotophos, diisopropyl fluorophosphate, dichlorvos, dimethoate,

dioxathion, disulfoton, dursban, ethion, ethoprop, fenamiphos, fenitrothion, ferthion, fosthiazate, isoxathion, lorsban, malathion, methamidophos, methidathion, metyl parathion, mevinphos, monocrotophos, naled, omethoate, oxon, oxydemeton-methyl, parathion, parathion-methyl, paraoxon, phorate, phosalone, phosmet, phostebupirim, phoxim, pirimiphos-methyl, quinalphos, temephos, terbufos, tetrachlorvinphos, triazophos, tribufos, trichlorfon), carbamates (aldicarb, carbendazim, carbofuran (Furadan), carbaryl (Sevin), ethienocarb, fenobucarb and methomyl), organochlorides (aldrin, beta-HCH, carbon tetrachloride, chlordane, cyclodiene, 1,2-DCB, 1,4-DCB, 1,1-DCE, 1,2-DCE, DDD, DDE, DDT, dicofol, dieldrin, endosulfan, endrin, heptachlor, kepone, lindane, methoxychlor, mirex, pentachlorophenol, tertadifon, and toxaphene), phosphorothioate (coumaphos, pirimiphos-methyl) and pyrethroids (allethrin, bifenthrin, cyfluthrin, cypermethrin, cyphenothrin, deltamethrin, esfenvalerate, etofenprox, fenpropathrin, fenvalerate, flucythrinate, imiprothrin, lambda-cyhalothrin, metofluthrin, permethrin, prallethrin, resmethrin, silafluofen, sumithrin, tau-fluvalinate, tefluthrin, tetramethrin, tralomethrin, and transluthrin).

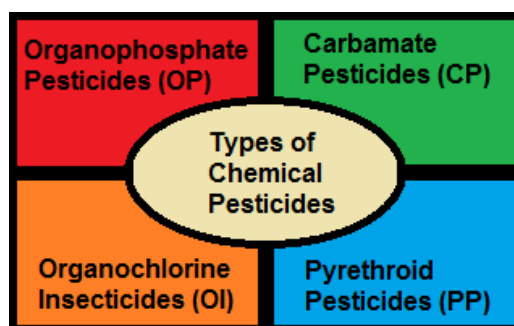

Figure 2. Main types of chemical pesticides applied in agriculture and industry.

An organochloride is an insecticide containing at least one covalently bonded chlorine atom. Their use is not recommended in food animals inasmuch as their persistence in animal tissues conducts to their input in the human food chain. Such pesticides are still industrially applied and although they have a non-animal use, the intoxication of animals can be presented. Among the effects produced by their intoxication are nervous excitement, tremor, convulsions, and death. They can inhibit different enzymes being acetylcholinesterase one of them. An organophosphate is an organic ester of phosphoric or thiophosphoric acid, which is the basis of many insecticides, herbicides and nerve gases. In accordance with the U.S. Environmental Protection Agency (EPA), these pesticides are very highly toxic to bees, wildlife, and humans due that they are organophosphorus compounds very pervasive. Fortunately, in a biosensor they can be detected with facility, since they inhibit the reaction of hydrolysis catalyzed by acetylcholinesterase. A carbamate is any organic ester derived of carbamic acid, which is used as insecticide to kill insects. These have been used in certain medications and insecticides. They are toxic and may cause convulsions and death through ingestion or skin contact. Such pesticides can cause reversible inhibition of acetylcholinesterase and cholinesterase. A pyrethroid is a synthetic substance used as commercial household insecticide. They are generally harmless to human beings in low doses but can harm sensitive individuals. However, such pesticides are toxic to aquatic

organisms. Although few studies have been realized, enzymes such as acetylcholinesterase (AChE) are inhibited by these pesticides.

The rapid detection of organophosphates in the environment and public places is important for homeland security, human and animal water consumption, food safety, and health protection. Regularly, the determination of them is realized by the inhibition of the activity of selected enzymes such as acetylcholinesterase, cholinesterase, acid phosphatase, ascorbate oxidase, acetolactate synthase, urease, and aldehyde dehydrogenase. In addition, these pesticides can also be found in solvents (liquids, solids and gases that dissolve another solid, liquid, or gaseous solute giving place to a solution that is soluble in a certain volume of solvent at a specified temperature, which are used in dry cleanings, spot removers, glues, nail polish removers, detergents, and perfumes), plasticizers (additives used to increase the plasticity or fluidity of the materials to which they are added such as plastics, cement, concrete, wallboard, and clay), and extreme pressure additives (additives for lubricants used to decrease wear of the mechanical parts exposed to very high pressures). Although, organophosphorus and carbamate pesticides are commonly detected by means of inhibition of enzymes such as AChE, the substrates used to immobilize such chemicals have been modified and are being redesigned with the aim of increasing the efficiency of such detection, as well giving portability and reducing the cost.

An enzyme can be defined as a protein that catalyzes or modifies the rate at which chemical reactions proceed; hence it is not consumed during the reaction. The reaction rate can be slow or fast in accordance with the effect desired in the particular reaction. The initial molecules used in the catalysis are called substrates and the molecules produced during this process are called products. A substrate is a molecule upon which an enzyme acts. When a unique substrate is used, it binds with the enzyme active site, given place to an enzyme-substrate complex. The substrate is converted into one or more products that are released from the active site or part of an enzyme where substrates are bound. Next, the active site is free to accept other substrate molecules during the process of catalysis. The enzyme and the substrate have specific complementary geometric shapes that fit exactly into one another. When more than one substrate is involved, the molecules are bound in a specific order to the active site, before that they react together to produce products more elaborated. In active sites, the substrates undergo the chemical reaction associated with the catalysis, as shown in Figure 3. Almost all chemical reactions in a biological entity need enzymes in order to be developed at adequate rates. Since enzymes are choosy in the type and composition of the substrates, then there exists a small set of possible reactions, and therefore, the possible products are known for each pair involved in the enzyme-substrate complex. Enzymes reduce the activation energy for a chemical reaction, and it is increased due to them reach their equilibrium state more rapidly, and the products are formed faster.

Enzymes are formed by long linear chains of amino acids that can be folded to generate a three-dimensional product. Thanks to that each amino acid sequence is unique, different enzymes can be even used to fulfill the specific properties required for each application. Almost always, the size of enzymes is much larger than the substrates where they will act on, and the active site involved in the catalysis contains only a small portion of the enzyme

composed of 2 to 4 amino acids which are bound to the substrate. In some cases, the enzyme contains cofactors, which are non-protein chemical compounds, being either organic or inorganic, that are required for the protein's biological activity.

Enzymes can be generally considered as globular proteins containing from 62 amino acids to over 2,500 depending of their biological origin. Its activity is determined by biochemical composition and three-dimensional structure. These proteins are more or less soluble in aqueous solutions, inasmuch as they form colloidal solutions. Enzymatic activity is affected in two main types of chemical modifiers: the inhibiting molecules decrease the activity; while activator molecules, increase the activity. Most enzymes can be denatured, that is, they lose the tertiary structure and secondary structure that they have in their native state by means of the application of some external compound or heat. The chemical compounds that can be applied to denature enzymes are acids, salts or organic solvents. Depending on the nature of the enzyme, denaturation may be reversible or irreversible. In addition, such activity can be modified by temperature, chemical environment, and the substrate concentration. The complementary shape, charge and hydrophilic/hydrophobic characteristics of enzymes and substrates are responsible of the specificity found in the catalysis.

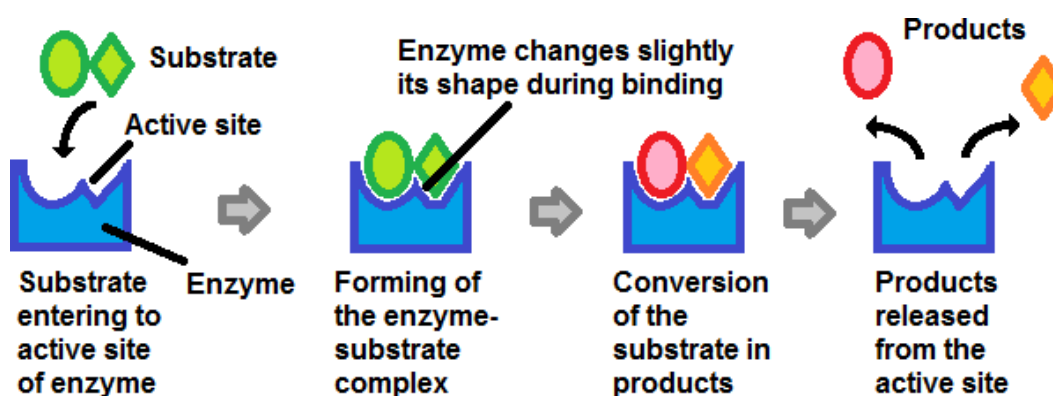

Figure 3. Process realized by an enzyme during the catalysis procedure (James & Tawfik, 2003).

The International Union of Biochemistry and Molecular Biology has classified to enzymes by the mechanism used in the catalysis:

- EC 1 Oxidoreductases: Enzymes that catalyze oxidation/reduction reactions to generate by means of the substrate a new product.
- EC 2 Transferases: Enzymes that transfer a functional group to the substrate to form a new product.
- EC 3 Hydrolases: Enzymes that catalyze the products using the cleavage of the substrate and the addition of water.
- EC 4 Lyases: Enzymes that catalyze the products by means of cleaving several bonds using hydrolysis and oxidation.
- EC 5 Isomerases: Enzymes that catalyze geometrical or structural changes within a substrate molecule with the aim of forming a single product.
- EC 6 Ligases: Enzymes that can catalyze the joining of two substrate molecules by forming a new chemical bond by hydrolysis.

Main enzymes used to enzymatic pesticide biosensors are acetylcholinesterase (AChE), butyrylcholinesterase (BChE) and cholinesterase (ChE), which belong to the type of enzymes considered as hydrolases whose classifications are EC 3.1.1.7, EC 3.1.1.8 and EC 3.1.1.8, respectively (Figure 4). Cholinesterase is a family of enzymes used to catalyze the hydrolysis of the neurotransmitter acetylcholine (ACh) into choline and acetic acid. AChE is found in the blood and neural synapses in multiple molecular forms. Two different three-dimensional forms can be identified: tetrameric G4 form (10) and monomeric G1 (4S). Such enzyme hydrolyses ACh more quickly. BChE is found primarily in the liver. This enzyme hydrolyses butyrylcholine more quickly.

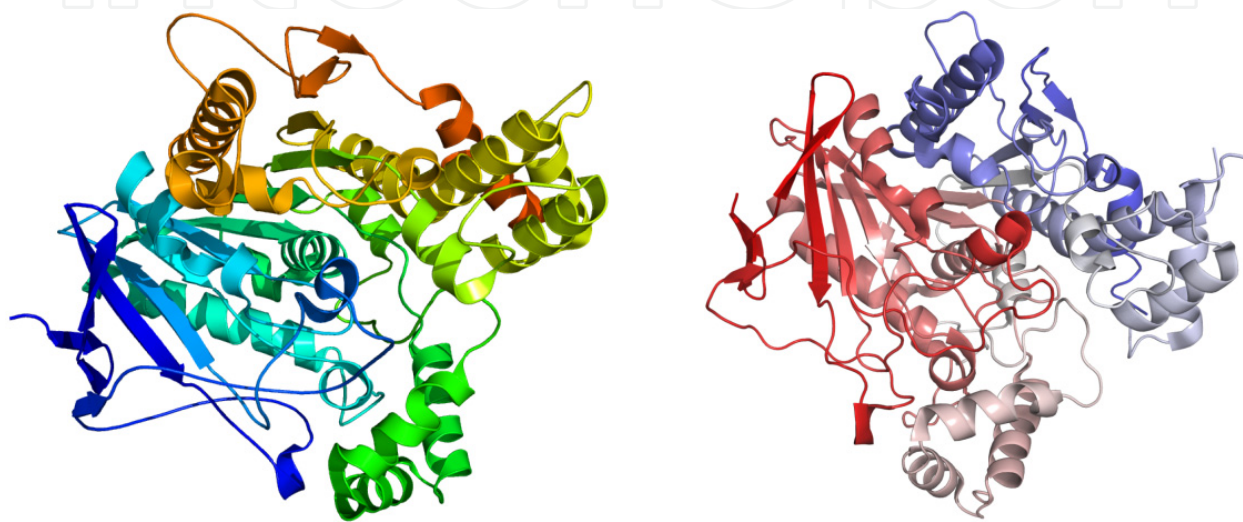

Figure 4. Enzymes used in pesticide biosensors: (left) acetylcholinesterase and (right) butyrylcholinesterase. Source: Protein Data Bank (PDB) (www.wwpdb.org).

Enzymes used in biosensors are highly selective to the substrates and sensitive to pH, temperature, inhibitors, denaturing and chelating agents. Two conditions must be fulfilled to adopt a specific immobilization method in a biosensor: 1) it must provide good mechanical stability, and 2) it must supply excellent conformation and freedom to the enzymes in their catalytic activity.

The cholinesterases (ChE's) have acted as key enzymes in areas such as neurobiology, toxicology, and pharmacology (Miao et al., 2010). AChE or true ChE is found in the central nervous system, bound to the cellular membranes of excitable tissues and associated with nerve transmission processes. Among the pesticides, organophosphates and carbamates form an important class of toxic compounds; their toxicity is based mainly on the inhibition of AChE during synapsis. However, small amounts of these classes of chemicals can also disrupt hormones and reduce their ability to successfully reproduce (Bonde and Storgaard 2002; Claman, 2004); and have been associated with special AChE specific cancers (Alavanja et al., 2004).

ACh is secreted by pre-synaptic membrane into synaptic cleft in neuromuscular junctions and cholinergic neurons. This neurotransmitter binds to ACh receptors (AChR) on the post-synaptic membrane, relaying the signal from the nerve as shown in Figure 5.

Although all AChRs respond to ACh, they also respond to different molecules that in physiological conditions are not present in synaptic cleft. In fact the AChR can be classified according to their affinities and sensitivities in muscarinic (an alkaloid from *Amanita muscaria* mushroom) and nicotine (from Solanaceae plants), or nicotinic receptors (nAChRs) and muscarinic receptors (mAChR). The nAChR (also known as "ionotropic" acetylcholine receptors) are ligand-gated ion channels permeable to Na⁺ and K⁺. In contrast, the mAChRs (also known as "metabotropic" acetylcholine receptors) are not ion channels, but belong instead to the superfamily of G-protein-coupled receptors that activate other ionic channels via a second messenger cascade. Both mAChR and nAChR are two main kinds of "cholinergic" receptors. In order to avoid over-stimulated AChR, ACh must be released from its receptor. This occurs only when the concentration of ACh in the synaptic cleft decreases.

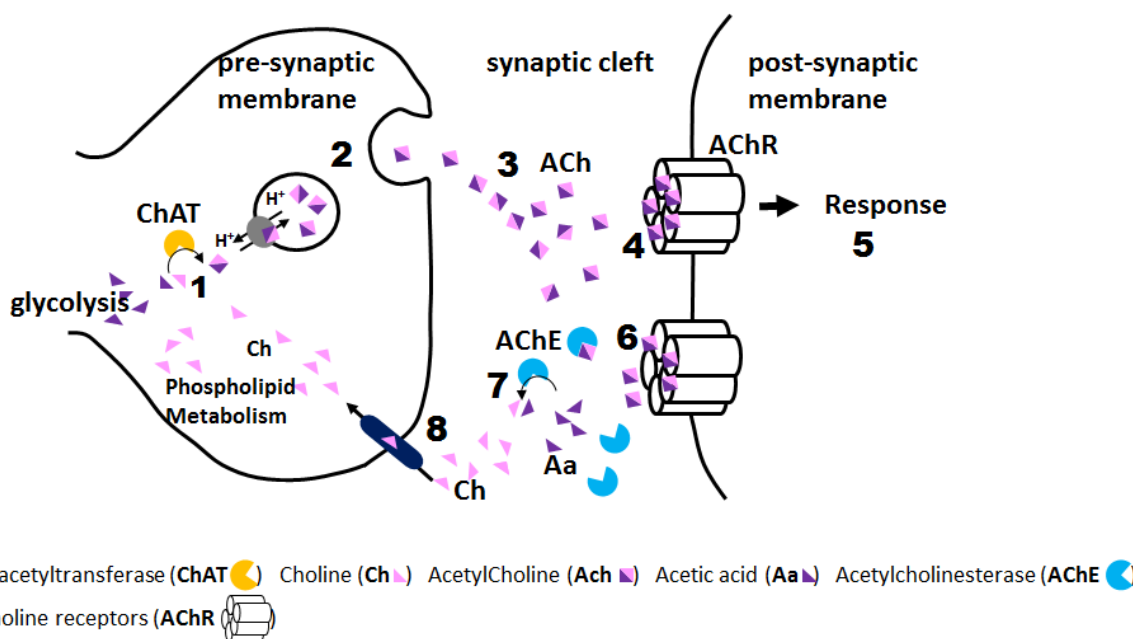

Figure 5. ACh production by Choline acetyltransferase in pre-synaptic terminal (1), ACh secretion to synaptic cleft (2), ACh accumulation in synaptic cleft (3), ACh binds to its receptor in post-synaptic membrane (4), Cellular response (5), ACh release from its receptor (6), AChE hydrolyzes ACh in choline and acetic acid (7), and Choline reuptake into the presynaptic membrane to make more ACh (8).

AChE catalyzes the hydrolysis of ACh into choline and acetic acid, an essential process for removing ACh from the nerve junction (see Figure 6). AChE can catalyze until 25000 molecules of acetylcholine (ACh) per second, whose value is the limit allowed by diffusion of the substrate. The active site of AChE contains 2 subsites: an anionic site and an esteratic subsite.

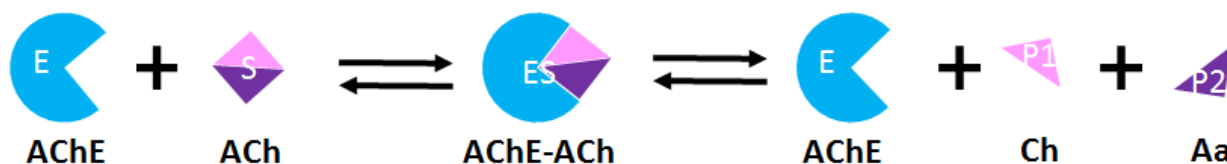

Figure 6. Hydrolysis of ACh by AChE in synaotic cleft.

Inhibition of AChE leads to accumulation of ACh in the synaptic cleft and results in impeded neurotransmission, as shown in Figure 7. During neurotransmission, ACh is released from the nerve into the synaptic cleft and binds to ACh receptors on the post-synaptic membrane, relaying the signal from the nerve. AChE found on the post-synaptic membrane, terminates the signal transmission by hydrolyzing ACh. The produced choline is carried again by the pre-synaptic nerve and ACh is synthesized by combining with acetyl coenzyme A used in metabolism (acetyl-coA) through the action of choline acetyltransferase (enzyme synthesized within the body of a neuron).

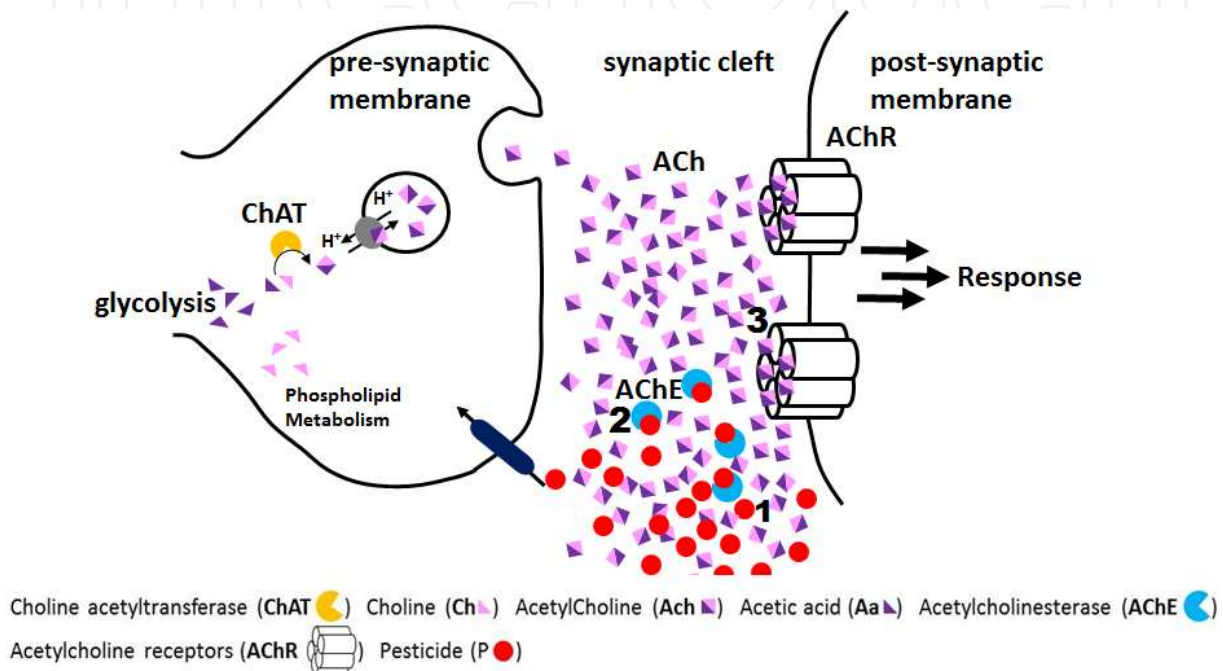

Figure 7. Pesticide accumulation in synaptic cleft (1), AChE inhibition by pesticide (2), and constant activation of AChR (3).

If AChE is unable of removing ACh, the muscle can continue moving uncontrollably.

Some pesticides such as organophosphates and carbamates can bind or inhibit AChE making unable to break down ACh. Organophosphates particularly include some of the more toxic pesticides, which can enter the human body through different routes such as skin absorption, inhalation and ingestion.

Repeated or prolonged exposure to organophosphates may result in the same effects as acute exposure including the delayed symptoms. Other effects include impaired memory and concentration, disorientation, severe depressions, irritability, confusion, headache, speech difficulties, delayed reaction times, nightmares, sleepwalking and drowsiness or insomnia.

For detecting the presence of pesticides in a biological entity, the essential step consists in realizing the immobilization of the enzyme on the transducers of the biosensors, as shown in Figure 8. Such immobilization can be obtained by means of dissolution of the enzyme in a buffer solution that is placed in an electrode surface, physical entrapment of the enzyme

inside a gel, chemical bond between the enzyme and a membrane or an organic or inorganic support or directly to the transducer made of Pt, Au, C, etc. The concentration of the pesticide in any biological entity has a linear or nonlinear correlation with the inhibition of the process of catalysis realized by the enzyme.

Chemicals that modify the action of cholinesterase are efficacious neurotoxins, which produce in humans and animals excessive salivation and eye-watering in low doses, after muscle spasms and finally death. Pesticides such as organochlorines, organophosphates, carbamates and pyrethroids can be used as insecticides, since they operate by combining with a residue of serine in the active site of acetylcholine esterase, so that the set inhibits the enzyme completely. Thus, the enzyme acetylcholine esterase breaks down the neurotransmitter ACh, which is delivered at nerve and muscle junctions in order to carry the muscle or organ to repose. AChE-based biosensors have higher sensitivity due to the more energetic enzyme inhibition by organophosphate pesticides. Other enzymes that have been used in pesticide biosensors are acetolactate synthase, acid phosphatase, alkaline phosphatase, tyrosinase, ascorbate oxidase, etc. Luciferase is used for biosensors based on bioluminescence. Organophosphorus hydrolase (OPH) is used as a recognition receptor in biosensors based on spectroscopic or electrochemical methods. Pairs of enzymes (bienzymatic biosensors) or set of three or more enzymes (multienzymatic biosensors) can be used to detect one or more types of pesticides in a same biosensor. Examples of systems are acetylcholinesterase and choline oxidase, acetylcholinesterase and cytochrome P450 BM-3 (CYP102-A1) mutant, acid phosphatase (AP) and glucose oxidase (GOD), phospholipase D and choline oxidase (ChO), etc.

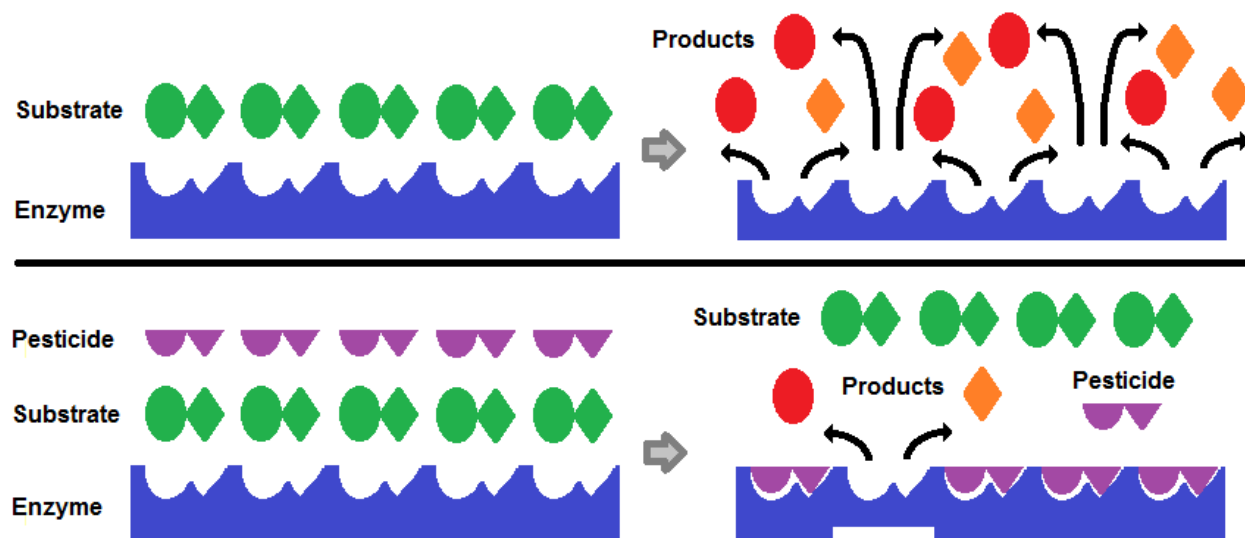

Figure 8. Inhibition of the catalytic reaction by means of pesticides: (up) absence of pesticide in biosensor, and (down) presence of pesticide in biosensor.

3. History of enzymatic pesticides biosensors

AChE has been isolated from several organisms to be used in almost all pesticide biosensors. In the early 1950s, potentiometric biosensors were the first devices used to detect pesticide.

Until middle of the 1980s, it was introduced the first integrated pesticide biosensor, whose operation depended on the inhibition of AChE. Advances in the science and technology have allowed obtaining genetically modified AChE and other enzymes, which have been used in the design of biosensors. Later on, different detection methods were introduced to realize the interface between the analyte and the biosensor: amperometric, conductometric, differential pulse voltammetry (DPV), chemiluminescence, piezoelectric, surface plasmon resonance, thermometer, resonant mirror, phosphorescence, fluorescence, etc. The main drawback of enzymatic pesticides biosensors is non-selectivity, i.e. they have only a unique or reduced signal transduction pathway. With the aim of increasing the selectivity of pesticide biosensors have been proposed alternative solutions: 1) the use of immunosensors, where antibodies operate as recognition receptors, i.e. organic compounds that control the physicochemical superficial properties and grafting process to improve the detection sensitivity and selectivity, and 2) the use of multiple enzymes in the same biosensor to increase the signal transduction pathways. The sensitivity of a biosensor and the stability of the catalyst depend of the immobilization method employed to design the interface between the analyte and the biochemical compounds involved in the detection. Despite of advances achieved until now in enzymatic pesticide biosensors, there are still a lot of technological aspects that require scientific research to carry on biosensors into exhaustive commercialization.

Commonly, most pesticides are measured by analytical techniques of laboratory such as processes based on gas chromatography or liquid chromatography, which are coupled with mass spectrometry. However, more and more requirements linked with the sample preparation, specialized chemical analytical equipment and personal with very high expertise are restricting the application of these techniques for realizing field-based detections. Therefore, it is necessary the use of rapid, reliable and low-cost methods that can be applied in the detection of pesticides in any place where a pesticide could be found. Hence, methodologies based on miniaturization of systems capable of determining precisely the presence or quantity of pesticide found in a sample even in insignificant quantities of matter and especially in very short times is the main objective to fulfill. An excellent possibility to obtain a very small system is a biosensor.

A biosensor can be defined as an analytical device capable of detecting an analyte (substance or chemical constituent interesting from an analytical point of view) that combines a biological material (nucleic acids, natural products, antibodies, enzymes, cell receptors, organelles, microorganisms, tissues, etc.), a biologically derived material (engineering proteins, aptamers, recombinant antibodies, biomass, bone, wood, etc.) or a biomimic (imprinted polymers, combinatorial ligands, biomimetic catalysts, synthetic receptors, etc.), with or integrated within a physicochemical transducer that will produce either discrete or continuous electronic signals proportional to the quantity of analyte present in a sample (see Figure 9).

Transducers in biosensors may be optical (optical fibers, waveguides, interferometers, fiber gratings, ring resonators, and photonic crystals), electrochemical (pH, polarographic,

capacitive, potentiometric or conductometric probes, amperometric, etc.), micromechanical, piezoelectric, magnetic or thermometric. Last two types of biosensors are rare. Biosensors have been applied to detect the presence of pesticides in a large variety of biological samples such as body fluids, food samples, cell cultures and environmental samples.

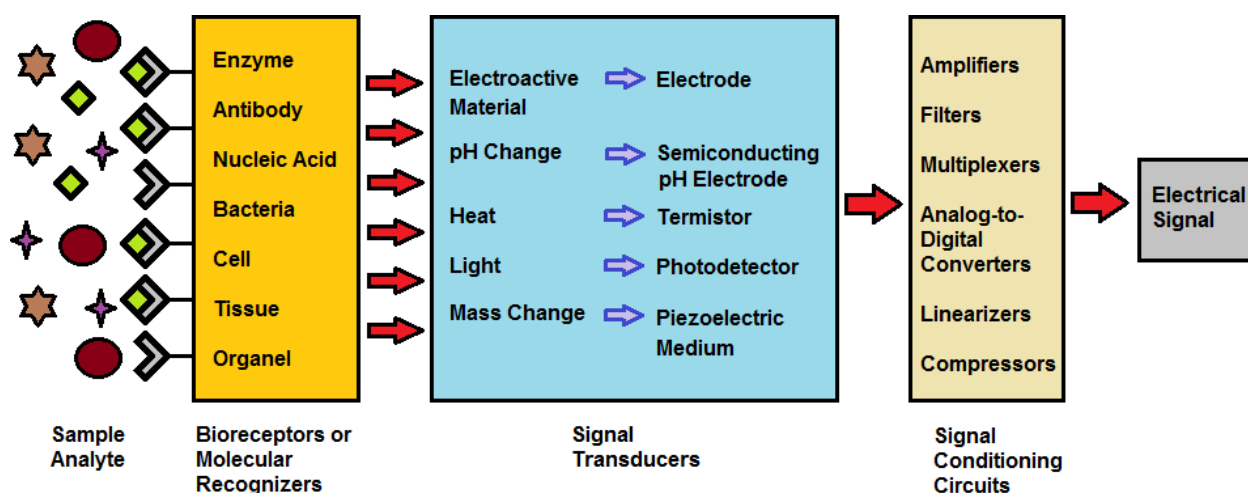

Figure 9. Biosensor operating principle: main subsystems.

A great number of different technologies have been developed to design biosensors, unfortunately, not all them are used in the different application types. In Figure 10, the key biosensor technologies that are being used today are illustrated. Biosensors applying electrochemical, piezoelectric, and optoelectronic principles have experienced the highest technological performance until now. A bioluminescent biosensor exploits the phenomena of visible light emission in biological entities due to the oxidation of organic compounds mediated by a catalytic enzyme. The light generation depends on the chemical reaction kinetics. This type of biosensor requires a photodetector to transduce the light emitted by the biological entity to an electrical signal. An electrochemical biosensor exploits the detection of physicochemical properties of electroactive substances to realize the biorecognition that provides the measurable signal: electrical current, voltage, resistance or superficial charge. An optical biosensor exploits two different strategies: 1) changes in light absorption between the reactants and products of a chemical reaction mediated by enzymes or 2) measurements of the output light by a luminescent process. A piezoelectric biosensor makes use of the change in frequency of a piezoelectric crystal, which is proportional to the mass of absorbed material as product of the chemical reaction catalyzed by enzymes. A special case is associated with a resonant mirror (RM) biosensor that uses the evanescent field emitted in a waveguide to determine changes in the refractive index at the sensing biochemical surface. In a thermistor-based biosensor, the temperature change induced by the enzyme-catalyzed reaction is exploited to determine the concentration of pesticide.

Pesticide biosensors can make use of the approach called flow injection analysis (FIA), which injects a plug of sample into a flowing carrier stream to realize a chemical analysis (Marinov et al., 2011). In this method, the sample is injected into a continuous flow of carrier solution that mixes the analyte with other continuously flowing solutions before reaching

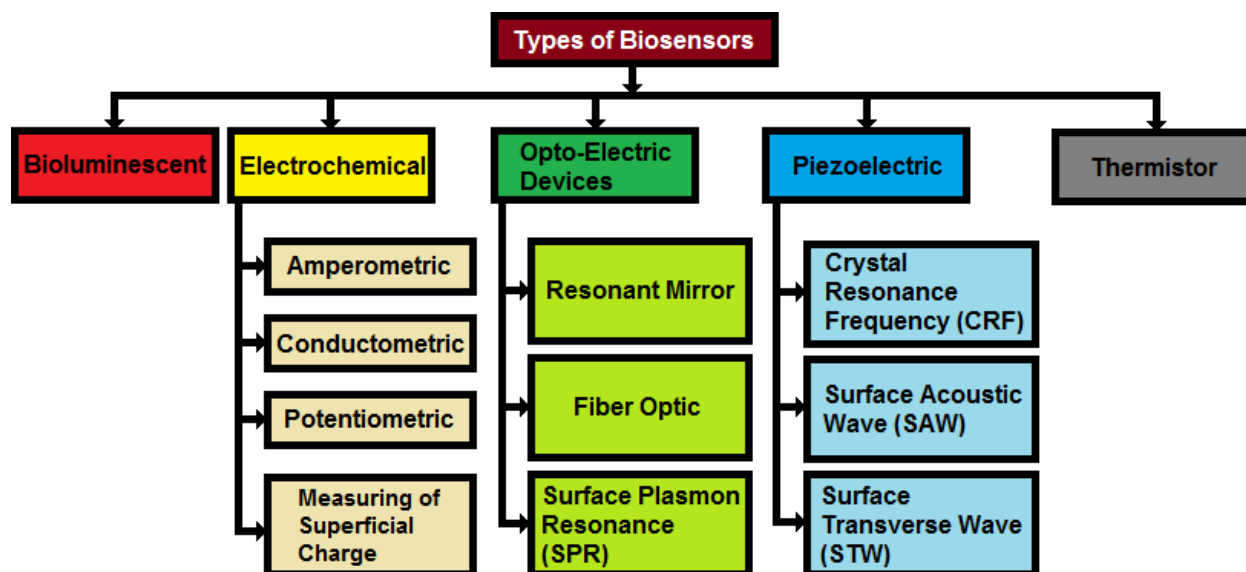

Figure 10. Types of Biosensors applied in several fields of engineering.

any type detector contained in a biosensor. Thus, this method dramatically increases the precision of the measurement and enormously reduces the response time. In addition, this technique allows designing non-disposable or reusable biosensors. In miniaturized systems, exhaustive use of microfluidic devices such as microvalves, micromixers, and micropumps is associated with the design of this system (Vargas-Bernal, 2006). The mixing is realized through radial and convection diffusion with a reagent for a period of time before the sample reaches the detector. A study of fluid dynamics must be considered to determine the parameters required for controlling the quantity of solution delivered to the detector (Vargas-Bernal, 2007). Chemical reactions can be implicated during the mixing of chemical solutions; therefore a biochemical study also is associated to this design. In the same way, thermal study can be considered when a large time of mixing is implicated. The detectors used in FIA systems are colorimeter, fluorimeter, ion-selective electrode, amperometric, conductometric, potentiometric or capacitive. Pesticides such as paraoxon ethyl, monocrotophos and dichlorvos have been detected by this type of systems.

If multiple samples must be analyzed at the same time, then a microarray of biosensors is used. A microarray is defined as a 2D array on a solid substrate, which is normally a glass slide or silicon thin-film cell that distributes large amount of biological material through the use of a high-throughput screening. Millions of biochemical tests are realized by means of robotics, data processing and control software, liquid handling devices, and sensitive detectors. This process allows identifying pesticides and other chemicals in different samples extracted of the same biological entity to analyze. Each element in such array is called assay. An enzyme-linked immunosorbent assay (ELISA) can detect the presence of pesticide in a liquid sample or wet sample disposed in a site of the microarray of biosensors. Each assay can contain different types of enzymes or different quantity of them with the aim of obtaining an image that illustrates the differences achieved in biosensing of the analyte. This type of array is desirable when a calibration process will be realized by the characterization for developed biosensors. Enzymes with high turnover numbers are

preferred to obtain rapid response. The last asseveration is related with the increase of sensitivity of the assays and such rise in response can generate highly coloured, fluorescent or bioluminescent products during the catalytic reaction.

4. Advances in optical biosensors

Biosensors using optical detection are based in enzymatic reactions for altering the optical properties of some substances with the aim of allowing them either to change in light adsorption between the reactants and products of a reaction, or to measure the light output by a luminescent process. Generally, an optical biosensor is formed by several subsystems: a light source, a set of optical components used to generate a light beam with particular characteristics and to focus the beam to a modulating agent, a modified sensing head, and a photodetector (Jiang et al., 2008). Amongst the means employed for this type of detection are surface plasmon resonance (SPR), waveguides or evanescent wave, resonant mirrors, fluorescence, phosphorescence, and chemi/bioluminescence to analyze biomolecular interactions. These biosensors determine the affinity and kinetics of the molecular interactions in real time without requiring molecular tags or labels. The advantages of this type of biosensors are: 1) multicomponent detection due to intrinsic molecular specificity in near infrared range, 2) robustness, 3) remote sensing, and 4) absence of electromagnetic fields or surface potentials, which can modify the biological entities or the result of the detection.

Surface plasmon resonance is a method based on resonant collective oscillation of valence electrons in a solid stimulated by incident light, whose frequency matches the natural frequency of surface electrons oscillating against the restoring force of positive nuclei of the solid (see Figure 11). Such solid regularly is gold or silver, which must be coated with target analyte. These metals are placed as a wall of a thin microfluidic flow-cell, where an aqueous buffer solution containing biological entity with pesticide is induced to flow across of a tubular section by injecting it through this flow-cell. Next, light (visible or near infrared) is emitted through the glass slide and onto the gold surface to fulfill the condition of SPR, the optical reflectivity of the gold changes very sensitively with the presence of biomolecules on the gold surface or in a thin coating on the gold composed of biopolymers or another type of biological membrane. The high selectivity of the optical response is due to the fact that there is a very efficient, collective excitation of conduction electrons near the gold surface. The detection occurs only at a particular angle and wavelength of incident light (total internal reflection) and it is highly dependent on the surface of the gold used either as a thin film or a nanostructured material. The extent of binding between the solution-phase interactant and the immobilized interactant is easily observed and quantified by monitoring the reflectivity change between input and output. The optical signal obtained is proportional to the volume of pesticide bound near the surface. One of the most important advantages of SPR is its high sensitivity without any fluorescent or phosphorescent interactant. Plasmons are only originated at the interface between the metal and a dielectric material commonly glass. The minimum feature size is defined by the diffraction limit achieved in interface, and it is of the order of wavelength of the light, that is, in the range of nanometers to micrometers.

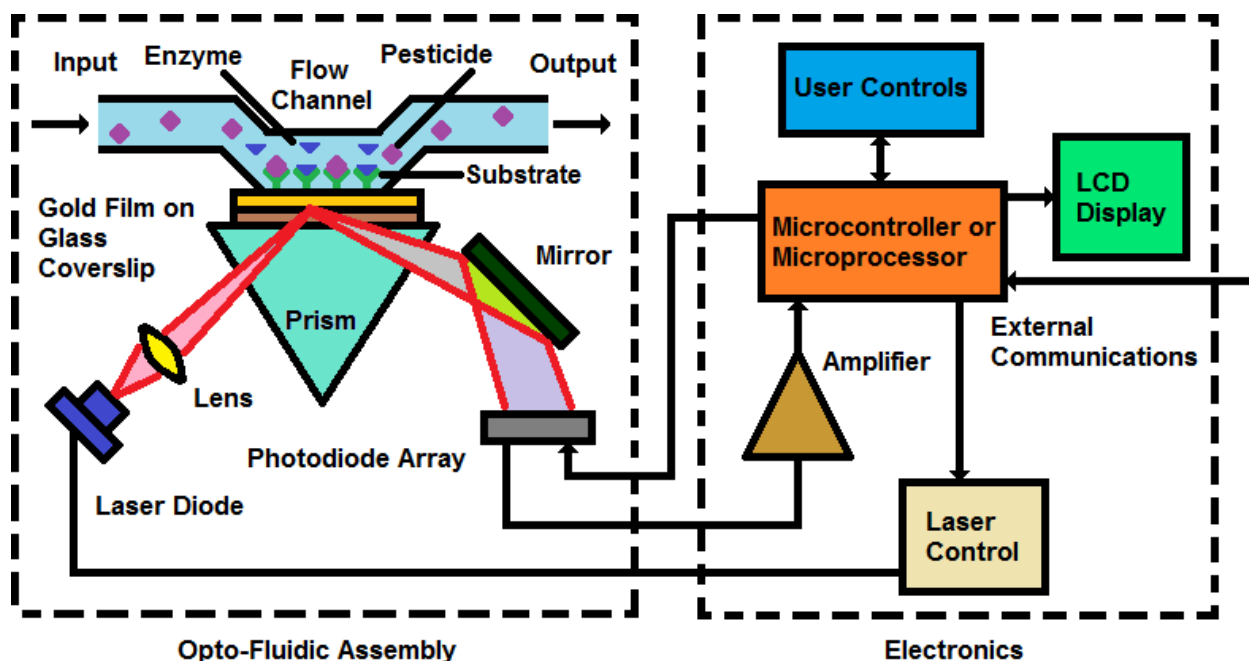

Figure 11. Optical biosensor based on surface plasmon resonance (SPR).

Amongst the advantages offered by this method are: 1) optical biosensors based on SPR render a label-free, fast, specific and sensitive alternative to develop laboratory analytical techniques, 2) SPR allows the study of macromolecules in real time and their interactions with the aim of determining specificity, interaction models, kinetic rates, equilibrium constants, thermodynamic constants, and epitope mapping, 3) SPR biosensors detect small (pesticides), medium, and large (proteins) biological analytes at different concentrations achieving minimum values such as 0.1 to 1 ng/ml, and 4) SPR biosensors can be applied to medicine, environmental protection, food and drug screening and security. Pesticides such as atrazine, chlorpyrifos, carbaryl, DDT, and simazine can be detected by this approach of biosensing. Nafion coated SPE biosensors using as inhibiting enzyme the butyrylcholinesterase can detect low levels of pesticides.

Prism in Figure 11 can be substituted with a single-mode or multi-mode optical fiber. The new system has additional advantages such as high sensitivity and it does not require the use of labels. These systems can be operated in two different modes: localized SPR (LSPR) and propagating SPR (PSPR). Optical fibers to be used must be side-polished to expose the core to the gold thin film and covered in the rest of the fiber. Fibers are susceptible to deformation, and hence, they can present changes in light polarization carrying to surface plasmon strength and do not diffuse resultant signal. A thin layer of ceramic material is used to adjust the refractive index of the wavelength desired.

An optical biosensor based on evanescent wave (EW) combines the use of molecular recognition by means of enzymes with the signal-transduction capability of a waveguide or optical fiber to detect changes in light intensity between their extremes, as shown in Figure 12.

Visible or near infrared light is emitted by a LED or a laser, and it is propagated through a waveguide or optical fiber with refractive index n_1 by multiple total internal reflections in

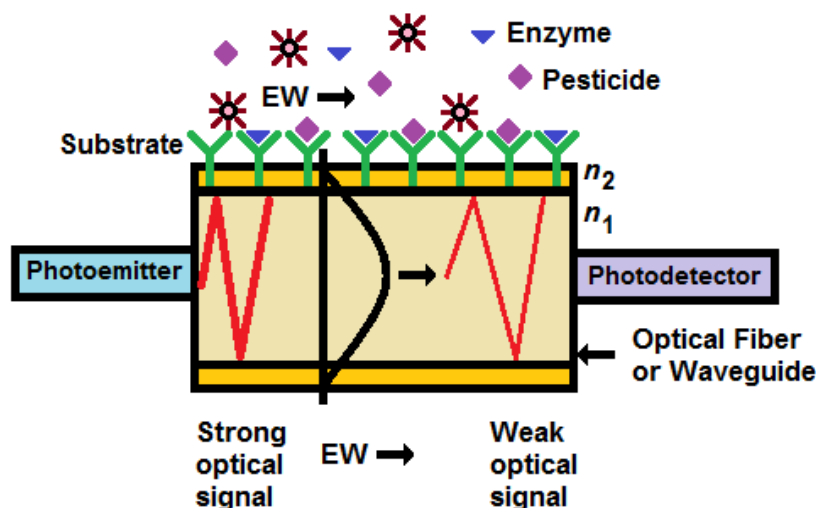

Figure 12. Evanescent wave biosensor for pesticides based on optical fiber or waveguide.

the optical fiber or waveguide axis, an electromagnetic wave (EM) called evanescent wave is produced in the optically less dense external medium with refractive index n_2 . If $n_1 > n_2$, then evanescent field penetrates into optical fiber or waveguide making that surface-bound molecules interact with the incident light. Energy optical absorption by the molecules favors the attenuation or reduction of light intensity reflected in the waveguide or optical fiber. An output optical signal is detected by means of a photodetector and a value of concentration of pesticide is indirectly obtained, which is proportional to the quantity of attenuation presented. An optical waveguide split to the input beam into two arms (sensing and reference), and after a certain distance they are recombined again. During the path of length of the waveguide, light traveling in the sensing arm will have a phase shift in comparison with guided light in the reference arm. Among the advantages of this biosensor are large surface area, and good optical, dielectric, thermal, and acoustic properties. In this type of biosensor, there exists a linear relationship between peak area of the absorption bands and input concentrations. Two different approaches can be distinguished: 1) high sensitivity and 2) fast time resolution. Pesticides such as parathion, fenitrothion, and paraoxon have been detected by this type of biosensor.

Chemiluminescence is the light emission produced by the excitation generated as result of an exothermic chemical reaction. In such reaction, reactants create an excited electronic state, which is associated with the maximum enthalpy. Generally, products generated have lesser chemical energy with respect to the reactants. The energy gained during the reaction when it is lost, then produces light emission and heat. The electronic state decays into an electronic ground state through either fluorescence or phosphorescence, in accordance with the spin state of the state formed during the reaction. Fluorescence is the property of a substance of emitting light, when it has previously absorbed light or another electromagnetic radiation. Commonly, emitted light by the substance has a longer wavelength and lower energy that absorbed radiation. The excitation is produced by the absorption of light of sufficient energy to carry one electron of the valence state to conduction state. Phosphorescence is a special case of the fluorescence where light is re-emitted a lower intensity for up to several hours after the original excitation. This method offers the flexibility of controlling the amount of enzyme on a surface.

Chloroplast thylakoids can be used as biological units that detect herbicides such as atrazine and diuron in water samples or aqueous extracts of samples. Almost half of the herbicides actually used in agriculture inhibit the light reactions in photosynthesis. Thylakoids are disposed in form of membranes, which contain hundreds of molecules of chlorophyll that are used as light-trapping pigments required for photosynthesis. Enzymes and other molecules used in photosynthesis are added into thylakoid membranes. Two different types of photosensitive biological units can be designed through pigments and enzymes: Photosystem I and Photosystem II. Chlorophyll absorbs red and blue light, and scatters green light. In Figure 13, a fluidic optical biosensor can be used in the detection of herbicides, which is based on the inhibition of the hydrogen peroxide production generated by thylakoids, pesticide, and the light applied. Such production depends of the illumination applied by a LED into isolated thylakoids and whose activity is modified by the presence of different concentrations of pesticide. A chemiluminescence reaction is obtained when lysates containing luminol are oxidized by horseradish peroxidase (HRP). Chemiluminescence intensity is associated with the quantity of luminol, oxidant and catalyst, and any of these can be determined with this system. The presence of hydrogen peroxide reduces the photoemission generated by the system, which is detected by means of a photodetector and electronically quantified. This method makes use of superparamagnetic beads with the aim of reusing the biosensor and of regenerating the activity of the enzyme. Amongst the pesticides that have been detected by this method are triazinone, 2,4-Dinitro-6-isobutylphenol, diuron, atrazine, endosulfan, tebuconazole, paraquat, prometryn, etc.

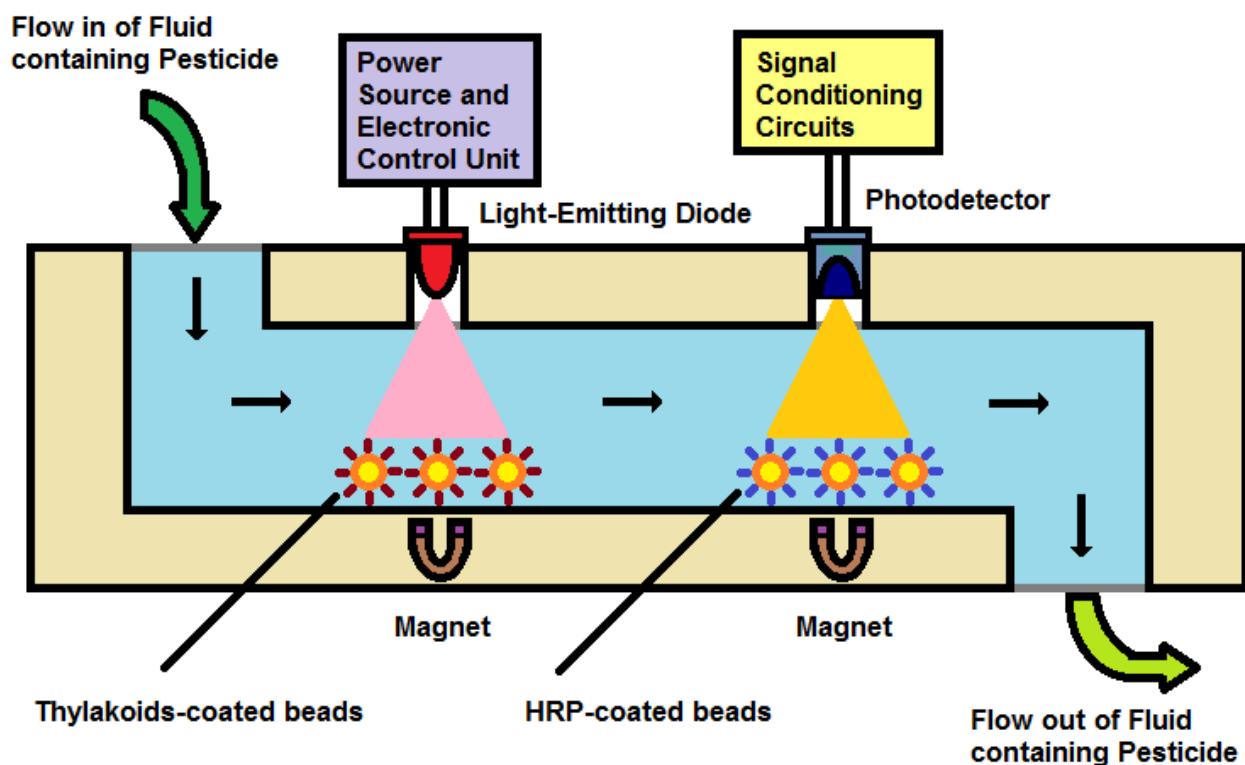

Figure 13. Optical biosensor based on chemiluminescence.

5. Advances in electrochemical biosensors

Electrochemical biosensors place suitable enzymes in their biorecognition layers to generate electroactive substances for the chemical detection through identification of similar compositions between the substrate and the analyte or the inhibition of the enzymatic activity in the substrate by the presence of analyte. Two main approaches are used: 1) enzyme inhibition (static detection or in repose), and 2) hydrolysis of pesticide (dynamic detection). Inhibition-based biosensors have been widely designed due to the simplicity of operation and a diversity of available enzymes. Pesticide enzymatic hydrolysis-based biosensors have a very fast catalytic reaction and exploit the use of flow injection analysis (FIA) to increase the response time. Electrochemical biosensors convert proportionally the chemical information obtained by the enzymes into a measurable electrical variable such as electrical current, voltage or resistance. Enzymes can be immobilized by four different methods adsorption, entrapment, covalent bonding, and cross-linking. Their efficiency is limited by the quantity of immobilized bioactive molecules on the sensor surface, inasmuch as these sensors have the characteristic of randomly adsorbing the analytes with bioefficiency and biofunctionality reduced. The actual trend consists in mitigating non-specific adsorption and creating tailor-made surfaces to control the immobilization of bioanalytes through specific receptor recognition interactions. Thanks to the technological advance, this type of biosensors offers the miniaturization of the detection systems with very attractive advantages with respect to other types of biosensors such as portability, rapid measurement, repeatability, robustness, compactness, excellent selectivity, high sensitivity, wider linear range, and reduction of the volume of sample to realize the recognition. This type of biosensors uses four different sensing modes potentiometry or voltammetry, amperometry, surface charge using field-effect transistors (FETs), and conductometry.

A potentiometric biosensor makes use of ion-selective electrodes to convert a biochemical reaction into an electrical signal. In the simplest terms, it consists of an immobilized enzyme membrane surrounding the probe from a pH-meter, where the catalyzed reaction generates or absorbs hydrogen ions. An amperometric biosensor generates an electrical current or changes in electrical current when an electrical potential is applied between a pair of electrodes positioned in an electroactive biological membrane. Any analyte capable of being oxidized or reduced chemically can be used as candidate for amperometric detection. The analyte is oxidized at the anode or reduced at the cathode. A conductometric biosensor is based on modulation of resistivity of the selective material. In this type of biosensor, the material changes its conductivity due to its interaction with chemical species. Such material is clamped between two contact electrodes and the resistance of the entire device is measured. Other version of the same biosensor consists in measuring the electrical resistance between a pair of electrodes that interconnects a biological medium: a suitable counter-electrode and one electrode immersed in a solution of electrolyte. A more exhaustive analysis of these types of biosensors can be found in (Vargas-Bernal, 2007).

During enzymatic catalysis of the biochemical reaction are produced ions. The substrate contains three electrodes which are used to determine the electrical parameters: a reference

electrode, an active electrode and a sink electrode. In addition, a counter electrode can be used as an ion source when the ions are not present by any another medium. The target analyte associated with the reaction produces ions in the active electrode surface. The electrical parameters can be measured between different electrodes by means of electrical conductivity, current, voltage or superficial charge.

In AChE-based biosensors, ACh is used as substrate for the detection of organophosphorus and carbamate pesticides. The product obtained during the catalytic reaction is called thiocholine, it is measured using spectrometric, amperometric or potentiometric methods. The enzyme activity is indirectly related with the pesticide concentration found in the analyte. When a mixture of pesticides is present in an analyte, precaution should be had due to a change in the whole activity of the pesticides why it can be disguised or not clearly distinguished. Thus, a more sensitive biosensor must be used in this case, which is obtained by means of two or more enzymes containing different functional groups and a set of two or more types of substrates in the same biosensor. The set of enzymes used in a multienzymatic biosensor must be carefully chosen so that the enzyme employed in the actual reaction generates subsequent products that will be used in the next reaction by the subsequent enzyme in action. In the static biosensors, the number of consecutive measurements with the same biosensor is limited to the quantity of enzyme used in each measurement. Therefore, inhibition-based biosensors are disposable biosensors and are designed with this orientation for a cheaper cost. The main drawbacks of the inhibition-based biosensors are slow and tedious, due to they require multiple steps of reaction such as measuring initial enzyme activity (before being used), incubation with inhibitor, measurement of residual activity (after being used), and regeneration and washing (i.e., add more substrate and remove biochemical residues found). Inhibition-based biosensors have detected pesticides such as sulfometuron methyl (herbicide), atrazin, diazinon, dichlorvos, ziram, diram, zinc diethyldithiocarbamate, dithiocarbamates, malathion, parathion methyl, and paraoxon.

Biosensors containing a FIA system or dynamic biosensors have allowed to detect pesticides such as paraoxon, parathion, coumaphos, diazinon, methyl parathion, omethoate, dimethyl 2,2'-dichlorovinyl phosphate. The reactivation of the inhibited enzyme can be achieved by means of nucleophilic reagents which are oximes such as 2-pyridinealdoxime methiodide, 2-pyridinealdoxime methochloride, 1,1'-trimethylene bis 4-formylpyridinium bromide dioxime (TMB-4) and 2-pyridinealdoxime methiodide.

Gold nanoparticles (AuNPs or GNPs) can be used in biosensors for immobilizing biomolecules such as enzymes to provide better efficiency, environmentally amicable, and stability to them. Additionally, GNPs provide a conductive pathway that promotes electron transfer reactions to lower potentials and increases the surface hydrophilicity for immobilization of enzymes (Du et al., 2008). The formation of GNPs in layers with self-assembled monolayers (SAMs) of 11-mercaptopundecanoic acid (MUA) illustrated in Figure 14, allows a better electron transfer and a simple method to functionalize their surface by biomolecules. AChE has excellent activity to this substrate, since malathion, paraoxon, carbofuran, and phoxim can be detected in limits of detection very small using an

amperometric biosensor. Although, GNPs are competent to fabricate electrochemical biosensors, they are inherently instable and agglomerated by van der Waals forces. Therefore, protective agents must be added to them. Silk fibroin (SF) is a natural protein extracted from silkworm cocoon with thermal stability, nontoxicity, low cost and biocompatibility that can act as protective agent. GNPs and SF form a bioconjugated colloid that is used as substrate for the enzyme. Other chemicals used to generate SAMs with GNPs are alkanothiols, dialkyl disulfides and dialkyl sulfides.

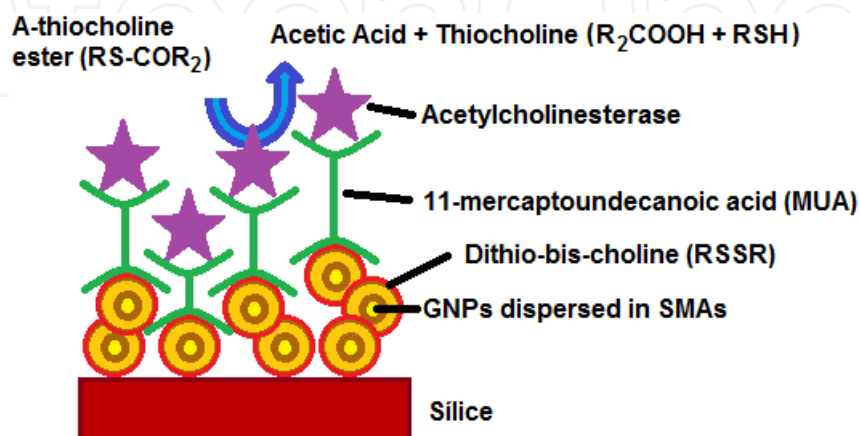

Figure 14. Electrochemical biosensor based on gold nanoparticles dispersed in SMAs.

The main drawback of amperometric biosensors based on AChE is related with the high potential that must be applied for maintaining constant the generation of enzymatic product, i.e. thiocholine, which has as consequence the instability of the biosensor. A solution has been applied to this problem, the use of mediators and highly conductive materials such as carbon nanotubes and other nanostructured materials. A mediator is an organic compound whose function consists in fixing a constant rate of enzymatic activity producing long-term stability.

A field-effect transistor (FET) is defined as a semiconductor device used for amplifying and switching electronic signals and power, which requires of an electric field to control the conductivity and tridimensional shape of a channel containing one type of charge carrier in a semiconducting material. These transistors have three terminals: source, drain and gate. Main electrical carrier can be an electron or a hole, which flows from the source to the drain. Source and drain terminals are connected to a semiconductor substrate called bulk through ohmic contacts. Between this pair of terminals is established a flow of current, which is controlled by the gate terminal. The conductivity of the channel is a function of the electric field applied to the gate terminal and the field applied between source and drain. Thus, gate terminal modulates the channel conductivity through the voltage applied to it. In a biosensor, gate terminal is modified with a substrate containing an enzyme with the aim of detecting very low concentrations of analytes containing pesticides which are made flowing through of it (see Figure 15); therefore, a change in the drain-source current is presented due to the changing of charge density on the gate surface. Such charge density is associated with the change of pH found in the gate terminal of the FET. A nonlinear relationship between the concentration of pesticide and

mutations must be carefully selected to give to enzymes better properties: higher affinity toward specific analytes, higher stability, and higher electron transfer rates.

Electrochemical detection either catalytic or by affinity continues playing an important role in many clinical, environmental, industrial, pharmaceutical, defense, and security applications thanks to their high sensitivity and selectivity (Ronkainen et al., 2010). The novel developments in nanotechnology and materials science have allowed overcoming or minimizing their drawbacks by adding properties that bulk materials cannot offer.

6. Future trends

In spite of the years of research and technological development achieved in biosensors, there is still a lot of work that must be done with the aim of designing the most efficient and sophisticated biosensor for determining both qualitative and quantitatively the presence of pesticides in any type of biological entity. This section discusses the predictable future perspectives in pesticide biosensor research activities, which are illustrated in Figure 16.

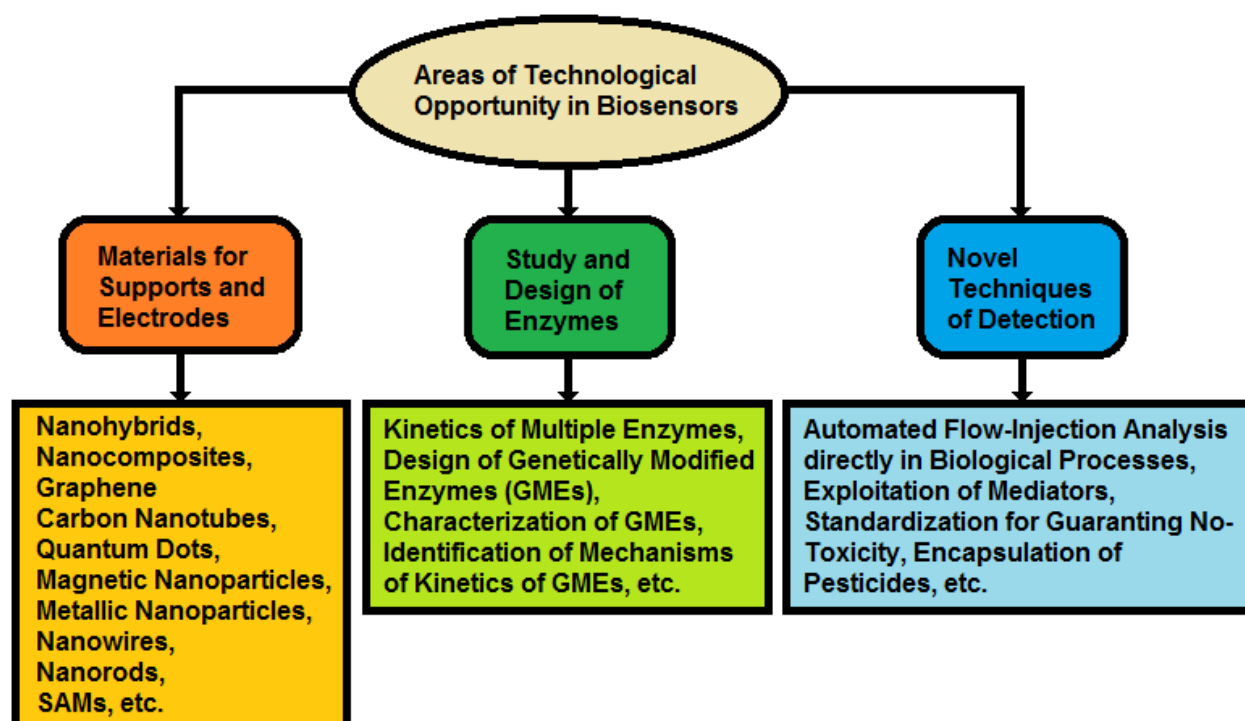

Figure 16. Future directions in scientific research related with biosensors.

A great diversity of electrical interfaces continues being developed with the aim of optimizing the performance of the biosensors. Amongst such interfaces are: field-effect transistor (FET) devices, nanotube arrays, nanoparticles, nanowires, electrodes, etc., as it was illustrated in Figure 9. With the reduction of size of the biosensors towards nanoscale, there is an urgent necessity of combining different methodologies to characterize and fulfill the performance desired through the manipulation of the interfaces linked in the recognition. Here, different strategies to increase such characteristics are studied as expectations of research and technological development towards novel biosensors.

6.1. Nanomaterials

One of the most important challenges is the extensive use of metals, ceramics and polymers both as individual nanomaterials as well as nanocomposites or nanohybrid materials. The advantage of these materials allows producing a synergetic effect derived of combining their individual properties, while are eliminated their particular drawbacks. The introduction of materials as the graphene will be strategic to design nanohybrids materials with fast detection due to the excellent electron-transfer, acceptable stability, good reproducibility, and higher affinity to the substrates used for placing the enzyme (Wang, K. et al., 2011). Therefore, a new generation of biosensors to fulfill the parameters of performance required will be developed as for example, must search that the detection of levels can be realized in smaller periods. In the design of reusable biosensors, it is indispensable the whole integration of subsystems for their strategic miniaturization. A biosensor will contain all blocks associated with the process: sampling of analyte, mixing of analyte and biochemical substances used in the reaction of detection such as buffers; separation of substances involved, delivery of substances for the catalysis, detection of pesticides, readout of levels, and regeneration of the substrate containing the enzyme. The use of microfluidics will allow the design of highly intelligent, integrated and high-throughput biosensors. The separation of substances could be realized by means of the integration of micro high-performance liquid chromatography (μ HPLCs).

The use of nanostructured materials as labels, signal enhancers or immobilizations supports is helping to obtaining highly sensitive analysis systems in pesticides biosensors. However, all their special properties have not been exploited at their maximum (Campàs et al. 2012). A lot of study must be realized with the aim of improving their stability and applicability. The use of magnetic particles as immobilization carriers in flow-injection analysis is in a first stage, since they will be strategic to give biosensors capacity of reuse.

A nanomaterial must be functionalized to be exploited as catalytic support, immobilization platform or as label to improve the quality of biosensing (Pérez-López & Merkoçi, 2011). The quality of biosensing is associated with three main parameters: sensitivity, stability and selectivity. Until now, different options of nanomaterials for biosensors have been proposed: carbon nanotubes (CNTs), metal nanoparticles (for example, gold nanoparticles (Au NPs)), magnetic nanoparticles (MNPs), nanowires (NWs), nanorods (NRs), nanocomposites (NCs), and quantum dots (QDs). Nanomaterials must be completely reproducible to guarantee their application in enzymatic pesticide biosensors, since any variation in their shape, dimension, or composition modifies the physicochemical properties required by each application (Hu & Li, 2011). The main applications of nanomaterials in biosensors are related with the supporting matrix or amplification tags. The processes of synthesis and bioconjugation of nanomaterials must be standardized to be applied in a mass production scale for the complete commercialization. In AChE biosensors, the use of nanomaterials such as carbon nanotubes, gold nanoparticles, zirconia nanoparticles, titania nanoparticles, and quantum dots of cadmium sulphide will enhance the OP pesticides determination due to that they require lower oxidation potentials, and will have rapid response and long storage stability (Periasamy et al., 2009).

6.2. Carbon nanotubes and their composites

The introduction of carbon nanotubes will have two strategic advantages: highly specific recognition and quasi-direct detection of biomolecules. Pristine carbon nanotubes cannot be applied directly in the detection; they must be functionalized either in the side walls or extremes to create active sites where chemical reactions with pesticides can be identified (Lei & Ju, 2010). Amperometric and voltammetric biosensors can be implemented by glassy carbon electrodes (GCE) covered with carbon nanotubes (Balasubramanian & Burghard, 2006). Properties such as efficient electron transfer from electrode surfaces to the redox sites of enzymes in an amperometric biosensor can be achieved by means of carbon nanotubes (Wang, J., 2005). When nanocomposites containing single-walled carbon nanotubes and Co phthalocyanine are used, properties such as high efficiency of sensing and minimal steric hindrance of the AChE active site can be obtained (Ivanov et al., 2011). In addition, lower working potential and minimal interferences from electrochemical active components are achieved. A great prospect for automatic monitoring of pesticides in water, have been proposed based on amperometric biosensor implemented by a Layer-by-Layer (LbL) assembly (Firdoz et al., 2010). This topology presents excellent electrocatalytic activity towards pesticides in water, due to the higher electrical conductivity of the composite material used. Poly(diallyldimethylammonium chloride)-Single-Walled Carbon Nanotubes/Acetylcholinesterase (PDDA-SWCNTs/AChE) multilayer films were deposited on glassy carbon electrode. This biosensor presents stability, good precision, low detection limit, and requires much lesser time to the determination.

The use of nanocomposites such as carbon nanotubes/Nafion could provide properties such as low potential of detection, high sensitivity, formation of a stable and highly conductive CNT surface, and high stability to the enzyme (Musameh et al., 2011). Nanocomposites such as Au-MWCNTs can also be applied to amperometric biosensors for achieving properties such as low detection limit, high electron transfer rates, high sensitivity, stability, wide linear dependence of concentration, large immobilization sites for the enzymes, and excellent anti-interference (Jha & Ramaprabhu, 2010; Ma et al., 2011). They have allowed detecting pesticides such as paraoxon and methyl parathion.

6.3. Ceramic materials

Ceramic materials such as zinc oxide (ZnO) can be used as a matrix for immobilization of AChE for a large period of time, under saline media and very low temperatures (Sinha et al., 2010). ZnO matrix designed in a sol-gel method offers stability, reproducibility, reduction of enzyme used, and operation at lower potentials. New options of substrates such as layered double hydroxides (LDHs) are being used for the immobilization of AChE distributed as insulator/semiconductor solid supports (Hidouri et al., 2011). A LDH is a hydrotalcite-like material with two-dimensional nanostructured anionic clays. Due to their lamellar structure formed by two types of metallic cationic species and interlayer domains occupied by anionic species, they have a large surface area, high anion exchange capacity, biocompatibility, tunable surface, and porosity properties. These advantages are exploited as host structures

for biomolecule immobilization. Combination between enzymes and LDHs is generating biohybrid materials, which are convenient for the development of electrochemical biosensors.

6.4. Genetically modified enzymes

The use of genetically modified enzymes will be extended with the aim of: 1) reducing the cross-reactivity, 2) developing simple, stable, regenerable, reliable and sensitive detection methods, 3) discriminating between the contributions to the response signal of other nonspecific interactions and transport phenomena of the real monitoring of the biointeraction among detection, kinetic and affinity analysis, and 4) searching the development of mimic systems (Puiu et al., 2012). Due to the high affinity between mutant enzymes and pesticides, detection methods in water or liquid foods are being developed (Febbraio et al., 2011). The detection of pesticides in this type of media implies high stability toward temperature, organic solvents, and pH. Such advantages will must to be exploited to design multienzymatic biosensors for real-time, qualitative, and quantitative identification of a wide range of pesticides. The use of artificial neural networks (ANNs) can be a very useful tool for the design of electronic tongues (containing biosensors for multiple concentrations of pesticide or biosensors for different pesticides).

6.5. Quantum dots

Actually, water-soluble bioconjugated quantum dots (QDs) are being investigated as an option to detect pesticides in food formulations and drinking water (Vinayasa & Thakur, 2010). A quantum dot is a portion of semiconductor material whose excitons are confined in all three spatial dimensions. Their electronic properties are intermediate between those of bulk semiconductors and those of discrete molecules. Generally, the smaller the size of the crystal, the larger the band gap, the greater the difference in energy between the highest valence band and the lowest conduction band becomes, therefore more energy is needed to excite the dot, and concurrently, more energy is released when the crystal returns to its resting state. When they have different sizes, a gradient multi-layer nanofilm can be assembled with them. QDs are used as labels due to their fluorescence, photostability and prolonged excitation for image observation. In addition, the detection of multiple analytes is possible given that they have a wide spectral range (QD emits white light). Biochemical such as 3-phenoxybenzoic acid (PBA) and atrazine mercapturate (AM) placed on quantum dots operate as biomarkers of the pyrethroid insecticide and/or herbicide atrazine. The quantification of pesticides depends on competitive binding between the free particular pesticide and a known and well-established concentration of QD-bioconjugated pesticide toward the immobilized substrate of the biosensor. Materials commonly used to design QDs are cadmium sulphide, cadmium selenide, cadmium telluride, indium phosphide or gallium arsenide. QDs are more stable than enzymes or fluorescence dyes, hence the use of this type of supports will provide a more efficient biosensing system in a near future.

6.6. Metals

The use of metal-based nanostructures for electroanalytical applications is being consolidated thanks to the diversity of shapes synthesized: spheres, cubes, prisms, dendrites, stars, spikes, rods and flowers (Plowman, B.J. et al., 2011). The use of self-assembly monolayers (SAMs) is not restricted to applications of masking or inhibiting biological entities. They can be useful to impede electron transfer from the surface to the solution used for biodetection. Thus, SAMs allow a reduction of non-specific binding in the supports and therefore, a more efficient operation of the biosensor not only with respect to response time, and likewise sensitivity, selectivity and stability.

6.7. Paper

In search of alternative technological solutions, bioactive paper-based materials are being developed with the aim of detecting toxins in food packaging (Luckman & Brennan, 2010). The operating principle of this material consists in producing rapid colorimetric detection of one or more analytes simultaneously. A pesticide biosensor to realize the detection requires the encapsulation of biomolecules in sol-gel derived materials. Such encapsulation can be obtained by means of silica, where even gold nanoparticles can be grown to operate as indicators of bioactivity and a mechanism of signal generation. Silica allows the development of portable and recyclable solid-state analytical devices for detecting target molecules. Since sol-gel materials can be deposited on paper substrates by ink-jet printing, thus new enzymatically active paper materials suitable for biosensing of pesticides are obtained. The colorimetric biosensing platform by means of biocatalytic growth of sol-gel entrapped gold nanoparticles within a thin silica film coated onto a paper substrate is another viable solution. This type of biosensors is inexpensive, disposable, capable of transporting liquids via capillary action without external power, and environmentally friendly.

6.8. Novel techniques

Amongst novel techniques that will be exploited in a near future are: 1) the detection of pesticides during water cleaning through catalytic processes by means of biosensors based on nanomaterials, 2) the exploitation of properties derived of the mediators that produce non-enzymatic factors implicated in the inhibition quantification such as inclusion of polar functional groups and the use of surfactants, 3) the design of controlled methods to generate genetically modified enzymes with well-established properties, 4) the toxicity of nanomaterials used in biosensors must be widely studied with the aim of fulfilling with technical standards associated with each application, 5) the application of self-assembled monolayers (SAMs) to develop uniform supports for enzymes, and 6) the possible encapsulation of pesticides including biosensors to this scale of integration with the aim of optimizing their application.

7. Conclusions

The presence of pesticides in food, water, air and soil is of serious concern, since a minimum quantity of them can have catastrophic consequences in human beings. Enzymatic biosensors follow offering an excellent technical option to determine qualitative- and quantitatively the presence of pesticides. Definitively, the great progress achieved in last decade in materials science and biochemistry is impelling the development of novel biosensors capable of determining with high sensitivity, high selectivity, and long-term stability, the presence of pesticides. In accordance with the review proposed here, biosensors requires multiple physicochemical properties that a unique material used as mechanical and biochemical support of the analyte cannot provide by itself; hence a more sophisticated design will be the future trend to guarantee the efficiency and accuracy desired for each application and range of detection required. Although, limits of detection in the range nanomolar have been achieved until now; it is desirable that the newest biosensors can identify pesticides in the range of picomolar and attomolar. The introduction of nanobiosensors has allowed the development of user-friendly and in-field application devices. Due to the reproducibility problems, biosensors based on nanostructured materials will be introduced in the market until that their stability can be guaranteed. This chapter reviewed the advances that with respect to biosensors for detecting pesticides have been achieved and the future trends for coming related with their research and technological development.

Author details

Rafael Vargas-Bernal and Gabriel Herrera-Pérez
Instituto Tecnológico Superior de Irapuato, México

Esmeralda Rodríguez-Miranda
Universidad de Guanajuato, México

8. References

- Alavanja MC, Hoppin JA, and Kamel F (2004) Health effects of chronic pesticide exposure: cancer and neurotoxicity. *Annu. Rev. Public Health* 25: 155-197.
- Balasubramanian K and Burghard M (2006) Biosensors based on Carbon Nanotubes. *Anal. Bioanal. Chem.* 385(3): 452-468.
- Bonde JP and Storgaard L (2002) How work-place conditions, environmental toxicants and lifestyle affect male reproductive function. *Int. J. Androl.*, 25(5): 262-268.
- Campàs M, Prieto-Simón B and Marty J-L (2009) A review of the use of genetically engineered enzymes in electrochemical biosensors. *Sem. Cell Dev. Biol.* 20(1): 3-9.
- Campàs M, Garibo D and Prieto-Simón B (2012) Novel Nanobiotechnological Concepts in Electrochemical Biosensors for the Analysis of Toxins. *Analyst* 137(5): 1055-1067.
- Claman P (2004) Men at risk: Occupation and male infertility. *Fertil. Steril.* 81(S2): 19-26.

- Du D, Ding J, Cai J, Zhang J and Liu L (2008) In situ Electrodeposited Nanoparticles for Facilitating Electron Transfer across Self-Assembled Monolayers in Biosensor Design, *Talanta* 74(5): 1337-1343.
- Febbraio F, Merone L, Cetrangolo GP, Rossi M, Nucci R and Manco G. (2011) Thermostable Esterase 2 from *Alicyclobacillus acidocaldarius* as Biosensor for the Detection of Organophosphate Pesticides. *Anal. Chem.* 83(5): 1530-1536.
- Firdoz S, Ma F, Yue X, Dai Z, Kumar A and Jiang B (2010) A Novel Amperometric Biosensor based on Single Walled Carbon Nanotubes with Acetylcholine Esterase for the Detection of Carbaryl Pesticide in Water. *Talanta* 83(1): 269-273.
- Hidouri S, Baccar ZM, Abdelmelek H, Noguer T, Marty J-L and Campàs, M (2011) Structural and Functional Characterisation of a Biohybrid Material based on Acetylcholinesterase and Layered Double Hydroxides. *Talanta* 85(4): 1882-1887.
- Hu W and Li CM (2011) Nanomaterials-based Advanced Immunoassays. *WIREs Nanomed. Nanobiotechnol.* 3(2): 119-133.
- Ivanov AN (2011) Acetylcholinesterase Biosensor based on Single-Walled Carbon Nanotubes-Co Phtalocyanine for Organophosphorus Pesticides Detection. *Talanta* 85(1): 216-221.
- Jha N and Ramaprabhu S (2010) Development of Au Nanoparticles Dispersed Carbon Nanotube-based Biosensor for the Detection of Paraoxon. *Nanoscale* 2(5): 806-810.
- James L C and Twafik DS (2003) Conformational Diversity and Protein Evolution – A 60-Year-Old Hypothesis Revisited. *Trends Biochem. Sci.* 28(7): 361-368.
- Jiang X, Li D, Xu X, Ying Y, Li Y, Ye Z and Wang J (2008) Immunosensors for Detection of Pesticides Residues, *Biosens. Bioelectron.* 23(11): 1577-1587.
- Lei J and Ju H (2010) Nanotubes in Biosensing. *WIREs Nanomed. Nanobiotechnol.* 2(5): 496-509.
- Luckman RE and Brennan JD (2010) Bioactive Paper Dipstick Sensors for Acetylcholinesterase Inhibitors based on Sol-Gel/Enzyme/Gold Nanoparticle Composites. *Analyst* 135(8): 2028-2035.
- Ma JC and Zhang W-D (2011), Gold Nanoparticle-Coated Multiwall Carbon Nanotube-Modified Electrode for Electrochemical Determination of Methyl Parathion. *Microchim. Acta* 175(3-4): 309-314.
- Marinov I, Ivanov Y, Vassileva N and Godjevargova T (2011) Amperometric Inhibition-based Detection of Organophosphorus Pesticides in Unary and Binary Mixtures employing Flow-Injection Analysis. *Sensor. Actuat. B* 160(1): 1098-1105.
- Miao Y, He N and Zhu J-J (2010) History and New Developments of Assays for Cholinesterase Activity and Inhibition. *Chem. Rev.* 110(9): 5216-5234.
- Musameh MM, Hickey M and Kyratzis L (2011) Critical Evaluation of Electrode Design and Matrix Effects on Monitoring Organophosphate Pesticides using Composite Carbon Nanotube-Modified Electrodes. *Res. Chem. Intermed.* 37(7): 705-717.
- Pérez-López B. and Merkoçi A (2011) Nanomaterials based Biosensors for Food Analysis Applications. *Trends Food Sci. Tech.* 22(11): 625-639.

- Periasamy AP, Umasankar Y and Chen S-M (2009) Nanomaterials – Acetylcholinesterase Enzyme Matrices for Organophosphorus Pesticides Electrochemical Sensors: A Review. *Sensors* 9(6): 4024-4055.
- Plowman BJ, Bhargava SK and O'Mullane AP (2011) Electrochemical Fabrication of Metallic Nanostructured Electrodes for Electroanalytical Applications. *Analyst* 136(24): 5107-5119.
- Puiu M, Istrate O, Rotariu L and Bala C (2012) Kinetic Approach of Aflatoxin B1-Acetylcholinesterase Interaction: A Tool for Developing Surface Plasmon Resonance Biosensors. *Anal. Biochem.* 421(2): 587-594.
- Ronkainen NJ, Halsall HB and Heineman WR (2010) Electrochemical Biosensors. *Chem. Soc. Rev.* 39(5): 1747-1763.
- Sinha R, Ganesana M, Andreescu S and Stanciu L (2010) AChE Biosensor based on Zinc Oxide Sol-Gel for the Detection of Pesticides. *Anal. Chim. Acta* 661(2): 195-199.
- Vargas-Bernal R (2006) Selection of Micromixers for Biochemical Detection of Pesticides, Proceedings of the Electronics, Robotics and Automotive Mechanics Conference (CERMA), 2: 176-181, Cuernavaca, Morelos, Mexico.
- Vargas-Bernal R (2007) Topologies based on Microfluidics of Pesticide Biosensors, Proceedings of the Electronics, Robotics and Automotive Mechanics Conference (CERMA), 1: 579-584, Cuernavaca, Morelos, Mexico.
- Vinayasa AC and Thakur MS (2010) Focus on Quantum Dots as Potential Fluorescent Probes for Monitoring Food Toxicants and Foodborne Pathogens. *Anal. Bioanal. Chem.* 397(4): 1445-1455.
- Wang J (2005) Carbon-Nanotube based Electrochemical Biosensors: A Review, *Electroanalysis* 17(1): 7-14.
- Wang K, Li HN, Wu J, Ju C, Yan JJ, Liu Q and Qiu B (2011) TiO₂-decorated Graphene Nanohybrids for Fabricating an Amperometric Acetylcholinesterase Biosensor, *Analyst*. 136(16), pp. 3349-3354.

IntechOpen