

We are IntechOpen, the world's leading publisher of Open Access books Built by scientists, for scientists

4,800

Open access books available

122,000

International authors and editors

135M

Downloads

Our authors are among the

154

Countries delivered to

TOP 1%

most cited scientists

12.2%

Contributors from top 500 universities



WEB OF SCIENCE™

Selection of our books indexed in the Book Citation Index
in Web of Science™ Core Collection (BKCI)

Interested in publishing with us?
Contact book.department@intechopen.com

Numbers displayed above are based on latest data collected.
For more information visit www.intechopen.com



On Control Design of Switched Affine Systems with Application to DC-DC Converters

E. I. Mainardi Júnior¹, M. C. M. Teixeira¹, R. Cardim¹,
M. R. Moreira¹, E. Assunção¹ and Victor L. Yoshimura²

¹UNESP - Univ Estadual Paulista

²IFMT - Federal Institute of Education
Brazil

1. Introduction

In last years has been a growing interest of researchers on theory and applications of switched control systems, widely used in the area of power electronics (Cardim et al., 2009), (Deaecto et al., 2010), (Yoshimura et al., 2011), (Batlle et al., 1996), (Mazumder et al., 2002), (He et al., 2010) and (Cardim et al., 2011). The switched systems are characterized by having a switching rule which selects, at each instant of time, a dynamic subsystem among a determined number of available subsystems (Liberzon, 2003). In general, the main goal is to design a switching strategy of control for the asymptotic stability of a known equilibrium point, with adequate assurance of performance (Decarlo et al., 2000), (Sun & Ge, 2005) and (Liberzon & Morse, 1999). The techniques commonly used to study this class of systems consist of choosing an appropriate Lyapunov function, for instance, the quadratic (Feron, 1996), (Ji et al., 2005) and (Skafidas et al., 1999). However, in switched affine systems, it is possible that the modes do not share a common point of equilibrium. Therefore, sometimes the concept of stability should be extended using the ideas contained in (Bolzern & Spinelli, 2004) and (Xu et al., 2008). Problems involving stability analysis can many times be reduced to problems described by Linear Matrix Inequalities, also known as LMIs (Boyd et al., 1994) that, when feasible, are easily solved by some tools available in the literature of convex programming (Gahinet et al., 1995) and (Peaucelle et al., 2002). The LMIs have been increasingly used to solve various types of control problems (Faria et al., 2009), (Teixeira et al., 2003) and (Teixeira et al., 2006). This paper is structured as follows: first, a review of previous results in the literature for stability of switched affine systems with applications in power electronics is described (Deaecto et al., 2010). Next, the main goal of this paper is presented: a new theorem, which conditions hold when the conditions of the two theorems proposed in (Deaecto et al., 2010) hold. Later, in order to obtain a design procedure more general than those available in the literature (Deaecto et al., 2010), it was considered a new performance indice for this control system: bounds on output peak in the project based on LMIs. The theory developed in this paper is applied to DC-DC converters: Buck, Boost, Buck-Boost and Sepic. It is also the first time that this class of controller is used for controlling a Sepic DC-DC converter. The notation used is described below. For real matrices or vectors ($'$) indicates transpose. The set composed by the first N positive integers, $1, \dots, N$ is denoted by \mathbb{K} . The set of all vectors $\lambda = (\lambda_1, \dots, \lambda_N)'$ such that $\lambda_i \geq 0, i = 1, 2, \dots, N$ and $\lambda_1 + \lambda_2 + \dots + \lambda_N = 1$ is denoted by Λ . The convex combination

of a set of matrices (A_1, \dots, A_N) is denoted by $A_\lambda = \sum_{i=1}^N \lambda_i A_i$, where $\lambda \in \Lambda$. The trace of a matrix P is denoted by $Tr(P)$.

2. Switched affine systems

Consider the switched affine system defined by the following state space realization:

$$\dot{x} = A_{\sigma(t)}x + B_{\sigma(t)}w, \quad x(0) = x_0 \quad (1)$$

$$y = C_{\sigma(t)}x, \quad (2)$$

as presented in (Deaecto et al., 2010), where $x(t) \in \mathbb{R}^n$ is the state vector, $y(t) \in \mathbb{R}^p$ is the controlled output, $w \in \mathbb{R}^m$ is the input supposed to be constant for all $t \geq 0$ and $\sigma(t): t \geq 0 \rightarrow \mathbb{K}$ is the switching rule. For a known set of matrices $A_i \in \mathbb{R}^{n \times n}$, $B_i \in \mathbb{R}^{n \times m}$ and $C_i \in \mathbb{R}^p$, $i = 1, \dots, N$, such that:

$$A_{\sigma(t)} \in \{A_1, A_2, \dots, A_N\}, \quad (3)$$

$$B_{\sigma(t)} \in \{B_1, B_2, \dots, B_N\}, \quad (4)$$

$$C_{\sigma(t)} \in \{C_1, C_2, \dots, C_N\}, \quad (5)$$

the switching rule $\sigma(t)$ selects at each instant of time $t \geq 0$, a known subsystem among the N subsystems available. The control design problem is to determine a function $\sigma(x(t))$, for all $t \geq 0$, such that the switching rule $\sigma(t)$, makes a known equilibrium point $x = x_r$ of (1), (2) globally asymptotically stable and the controlled system satisfies a performance index, for instance, a guaranteed cost. The paper (Deaecto et al., 2010) proposed two solutions for these problems, considering a quadratic Lyapunov function and the guaranteed cost:

$$\min_{\sigma \in \mathbb{K}} \int_0^\infty (y - C_\sigma x_r)'(y - C_\sigma x_r) dt = \min_{\sigma \in \mathbb{K}} \int_0^\infty (x - x_r)' Q_\sigma (x - x_r) dt, \quad (6)$$

where $Q_\sigma = C_\sigma' C_\sigma \geq 0$ for all $\sigma \in \mathbb{K}$.

2.1 Previous results

Theorem 1. (Deaecto et al., 2010) Consider the switched affine system (1), (2) with constant input $w(t) = w$ for all $t \geq 0$ and let the equilibrium point $x_r \in \mathbb{R}^n$ be given. If there exist $\lambda \in \Lambda$ and a symmetric positive definite matrix $P \in \mathbb{R}^{n \times n}$ such that

$$A_\lambda' P + P A_\lambda + Q_\lambda < 0, \quad (7)$$

$$A_\lambda x_r + B_\lambda w = 0, \quad (8)$$

then the switching strategy

$$\sigma(x) = \arg \min_{i \in \mathbb{K}} \zeta' (Q_i \zeta + 2P(A_i x + B_i w)), \quad (9)$$

where $Q_i = C_i' C_i$ and $\zeta = x - x_r$, makes the equilibrium point $x_r \in \mathbb{R}^n$ globally asymptotically stable and from (6) the guaranteed cost

$$J = \int_0^\infty (y - C_\sigma x_r)'(y - C_\sigma x_r) dt < (x_0 - x_r)' P (x_0 - x_r), \quad (10)$$

holds.

Proof. See (Deaecto et al., 2010). □

Remembering that similar matrices have the same trace, it follows the minimization problem (Deaecto et al., 2010):

$$\inf_{P>0} \{Tr(P) : A'_\lambda P + PA_\lambda + Q_\lambda < 0, \lambda \in \Lambda\}. \quad (11)$$

The next theorem provides another strategy of switching, more conservative, but easier and simpler to implement.

Theorem 2. (Deaecto et al., 2010) Consider the switched affine system (1), (2) with constant input $w(t) = w$ for all $t \geq 0$ and let the equilibrium point $x_r \in \mathbb{R}^n$ be given. If there exist $\lambda \in \Lambda$, and a symmetric positive definite matrix $P \in \mathbb{R}^{n \times n}$ such that

$$A'_i P + PA_i + Q_i < 0, \quad (12)$$

$$A_\lambda x_r + B_\lambda w = 0, \quad (13)$$

for all $i \in \mathbb{K}$, then the switching strategy

$$\sigma(x) = \arg \min_{i \in \mathbb{K}} \zeta' P (A_i x_r + B_i w), \quad (14)$$

where $\zeta = x - x_r$, makes the equilibrium point $x_r \in \mathbb{R}^n$ globally asymptotically stable and the guaranteed cost (10) holds.

Proof. See (Deaecto et al., 2010). □

Theorem 2 gives us the following minimization problem (Deaecto et al., 2010):

$$\inf_{P>0} \{Tr(P) : A'_i P + PA_i + Q_i < 0, i \in \mathbb{K}\}. \quad (15)$$

Note that (12) is more restrictive than (7), because it must be satisfied for all $i \in \mathbb{K}$. However, the switching strategy (14) proposed in Theorem 2 is simpler to implement than the strategy (9) proposed in Theorem 1, because it uses only the product of ζ by constant vectors.

2.2 Main results

The new theorem, proposed in this paper, is presented below.

Theorem 3. Consider the switched affine system (1), (2) with constant input $w(t) = w$ for all $t \geq 0$ and let $x_r \in \mathbb{R}^n$ be given. If there exist $\lambda \in \Lambda$, symmetric matrices $N_i, i \in \mathbb{K}$ and a symmetric positive definite matrix $P \in \mathbb{R}^{n \times n}$ such that

$$A'_i P + PA_i + Q_i - N_i < 0, \quad (16)$$

$$A_\lambda x_r + B_\lambda w = 0, \quad (17)$$

$$N_\lambda = 0, \quad (18)$$

for all $i \in \mathbb{K}$, where $Q_i = Q'_i$, then the switching strategy

$$\sigma(x) = \arg \min_{i \in \mathbb{K}} \zeta' (N_i \zeta + 2P(A_i x_r + B_i w)), \quad (19)$$

where $\zeta = x - x_r$, makes the equilibrium point $x_r \in \mathbb{R}^n$ globally asymptotically stable and from (10), the guaranteed cost $J < (x_0 - x_r)' P (x_0 - x_r)$ holds.

Proof. Adopting the quadratic Lyapunov candidate function $V(\xi) = \xi'P\xi$ and from (1), (16), (17) and (18) note that for $\xi \neq 0$:

$$\begin{aligned}\dot{V}(\xi) &= \dot{x}'P\xi + \xi'P\dot{x} = 2\xi'P(A_\sigma x + B_\sigma w) = \xi'(A'_\sigma P + PA_\sigma)\xi + 2\xi'P(A_\sigma x_r + B_\sigma w) \\ &< \xi'(-Q_\sigma + N_\sigma)\xi + 2\xi'P(A_\sigma x_r + B_\sigma w) = \xi'(N_\sigma \xi + 2P(A_\sigma x_r + B_\sigma w)) - \xi'Q_\sigma \xi \\ &= \min_{i \in \mathbb{K}} \{ \xi'(N_i \xi + 2P(A_i x_r + B_i w)) \} - \xi'Q_\sigma \xi \\ &= \min_{\lambda \in \Lambda} \{ \xi'(N_\lambda \xi + 2P(A_\lambda x_r + B_\lambda w)) \} - \xi'Q_\sigma \xi \\ &\leq -\xi'Q_\sigma \xi \leq 0.\end{aligned}\tag{20}$$

Since $\dot{V}(\xi) < 0$ for all $\xi \neq 0 \in \mathbb{R}^n$, and $\dot{V}(0) = 0$, then $x_r \in \mathbb{R}^n$ is an equilibrium point globally asymptotically stable. Now, integrating (20) from zero to infinity and taking into account that $\dot{V}(\xi(\infty)) = 0$, we obtain (10). The proof is concluded. \square

Theorem 3 gives us the following minimization problem:

$$\inf_{P>0} \{ \text{Tr}(P) : A'_i P + PA_i + Q_i - N_i < 0, \quad N_\lambda = 0, \quad i \in \mathbb{K} \}.\tag{21}$$

The next theorem compares the conditions of Theorems 1, 2 and 3.

Theorem 4. *The following statements hold:*

- (i) *if the conditions of Theorem 1 are feasible, then the conditions of Theorem 3 are also feasible;*
- (ii) *if the conditions of Theorem 2 are feasible, then the conditions of Theorem 3 are also feasible.*

Proof. (i) Consider the symmetric matrices N_i , $i \in \mathbb{K}$, as described below:

$$N_i = (A'_i P + PA_i + Q_i) - (A'_\lambda P + PA_\lambda + Q_\lambda).\tag{22}$$

Then, multiplying (22) by λ_i and taking the sum from 1 to N it follows that

$$\begin{aligned}N_\lambda &= \sum_{i=1}^N \lambda_i N_i = \sum_{i=1}^N \lambda_i (A'_i P + PA_i + Q_i) - \sum_{i=1}^N \lambda_i (A'_\lambda P + PA_\lambda + Q_\lambda) \\ &= (A'_\lambda P + PA_\lambda + Q_\lambda) - (A'_\lambda P + PA_\lambda + Q_\lambda) = 0.\end{aligned}\tag{23}$$

Now, from (16), (18) and (22) observe that

$$\begin{aligned}A'_i P + PA_i + Q_i - N_i &= A'_i P + PA_i + Q_i - \left((A'_i P + PA_i + Q_i) - (A'_\lambda P + PA_\lambda + Q_\lambda) \right) \\ &= A'_\lambda P + PA_\lambda + Q_\lambda < 0, \quad \forall i \in \mathbb{K}.\end{aligned}\tag{24}$$

(ii) It follows considering that $N_i = 0$ in (16):

$$A'_i P + PA_i + Q_i - N_i = A'_i P + PA_i + Q_i < 0, \quad \forall i \in \mathbb{K}.\tag{25}$$

Thus, the proof of Theorem 4 is completed. \square

2.3 Bounds on output peak

Considering the limitations imposed by practical applications of control systems, often must be considered constraints in the design. Consider the signal:

$$s = H\zeta, \quad (26)$$

where $H \in \mathbb{R}^{q \times n}$ is a known constant matrix, and the following constraint:

$$\max_{t \geq 0} \|s(t)\| \leq \psi_o, \quad (27)$$

where $\|s(t)\| = \sqrt{s(t)'s(t)}$ and ψ_o is a known positive constant, for a given initial condition $\zeta(0)$. In (Boyd et al., 1994), for an arbitrary control law were presented two LMIs for the specification of these restrictions, supposing that there exists a quadratic Lyapunov function $V(\zeta) = \zeta'P\zeta$, with negative derivative defined for all $\zeta \neq 0$. For the particular case, where $s(t) = y(t)$, with $y(t) \in \mathbb{R}^p$ defined in (2), is proposed the following lemma:

Lemma 1. For a given constant $\psi_o > 0$, if there exist $\lambda \in \Lambda$, and a symmetric positive definite matrix $P \in \mathbb{R}^{n \times n}$, solution of the following optimization problem, for all $i \in \mathbb{K}$:

$$\begin{bmatrix} P & C_i' \\ C_i & \psi_o^2 I_n \end{bmatrix} > 0, \quad (28)$$

$$\begin{bmatrix} I_n & \zeta(0)'P \\ P\zeta(0) & P \end{bmatrix} > 0, \quad (29)$$

$$(Set \ of \ LMIs), \quad (30)$$

where (Set of LMIs) can be equal to (7)-(8), (12)-(13) or (16)-(18) then the equilibrium point $\xi = x - x_r = 0$ is globally asymptotically stable, the guaranteed cost (10) and the constraint (27) hold.

Proof. It follows from Theorems 1, 2 and the condition for bounds on output peak given in (Boyd et al., 1994). \square

The next section presents applications of Theorem 3 in the control design of three DC-DC converters: Buck, Boost and Buck-Boost.

3. DC-DC converters

Consider that $i_L(t)$ denotes the inductor current and $V_c(t)$ the capacitor voltage, that were adopted as state variables of the system:

$$x(t) = [x_1(t) \ x_2(t)]' = [i_L(t) \ V_c(t)]'. \quad (31)$$

Define the following operating point $x_r = [x_{1r} \ x_{2r}]' = [i_{Lr} \ V_{cr}]'$. Consider the DC-DC power converters: Buck, Boost and Buck-Boost, illustrated in Figures 1, 3 and 5, respectively. The DC-DC converters operate in continuous conduction mode. For theoretical analysis of DC-DC converters, no limit is imposed on the switching frequency because the trajectory of the system evolves on a sliding surface with infinite frequency. Simulation results are presented below.

The used solver was the LMILab from the software MATLAB interfaced by YALMIP (Lofberg, 2004) (Yet Another LMI Parser). Consider the following design parameters (Deaecto et al., 2010): $V_g = 100[V]$, $R = 50[\Omega]$, $r_L = 2[\Omega]$, $L = 500[\mu H]$, $C = 470[\mu F]$ and

$$Q_i = Q = \begin{bmatrix} \rho_1 r_L & 0 \\ 0 & \rho_2 / R \end{bmatrix},$$

is the performance index matrix associated with the guaranteed cost:

$$\int_0^{\infty} (\rho_2 R^{-1} (V_c - V_{cr})^2 + \rho_1 r_L (i_L - i_{Lr})^2) dt,$$

where ρ_1 and $\rho_2 \in \mathbb{R}_+$ are design parameters. Note that $\rho_i \in \mathbb{R}_+$ plays an important role with regard to the value of peak current and duration of the transient voltage. Adopt $\rho_1 = 0$ and $\rho_2 = 1$.

3.1 Buck converter

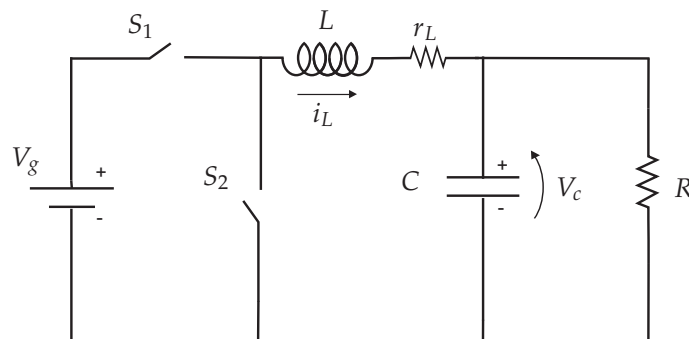

Fig. 1. Buck DC-DC converter.

Figure 1 shows the structure of the Buck converter, which allows only output voltage of magnitude smaller than the input voltage. The converter is modeled with a parasitic resistor in series with the inductor. The switched system state-space (1) is defined by the following matrices (Deaecto et al., 2010):

$$A_1 = \begin{bmatrix} -r_L/L & -1/L \\ 1/C & -1/RC \end{bmatrix}, \quad A_2 = \begin{bmatrix} -r_L/L & -1/L \\ 1/C & -1/RC \end{bmatrix},$$

$$B_1 = \begin{bmatrix} 1/L \\ 0 \end{bmatrix}, \quad B_2 = \begin{bmatrix} 0 \\ 0 \end{bmatrix}. \quad (32)$$

In this example, adopt $\lambda_1 = 0.52$ and $\lambda_2 = 0.48$. Using the minimization problems (11) and (15), corresponding to Theorems 1 and 2, respectively, we obtain the following matrix quadratic Lyapunov function

$$P = 1 \times 10^{-4} \begin{bmatrix} 0.0253 & 0.0476 \\ 0.0476 & 0.1142 \end{bmatrix},$$

needed for the implementation of the switching strategies (9) and (14). Maintaining the same parameters, from minimization problem of Theorem 3, we found the matrices below as a solution, and from (10) the guaranteed cost $J < (x_0 - x_r)'P(x_0 - x_r) = 0.029$:

$$P = 1 \times 10^{-4} \begin{bmatrix} 0.0253 & 0.0476 \\ 0.0476 & 0.1142 \end{bmatrix},$$

$$N_1 = -1 \times 10^{-6} \begin{bmatrix} 0.2134 & 0.0693 \\ 0.0693 & 0.0685 \end{bmatrix}, \quad N_2 = 1 \times 10^{-6} \begin{bmatrix} 0.2312 & 0.0751 \\ 0.0751 & 0.0742 \end{bmatrix}.$$

The results are illustrated in Figure 2. The initial condition was the origin $x = [i_L \ V_c]' = [0 \ 0]'$ and the equilibrium point is equal to $x_r = [1 \ 50]'$.

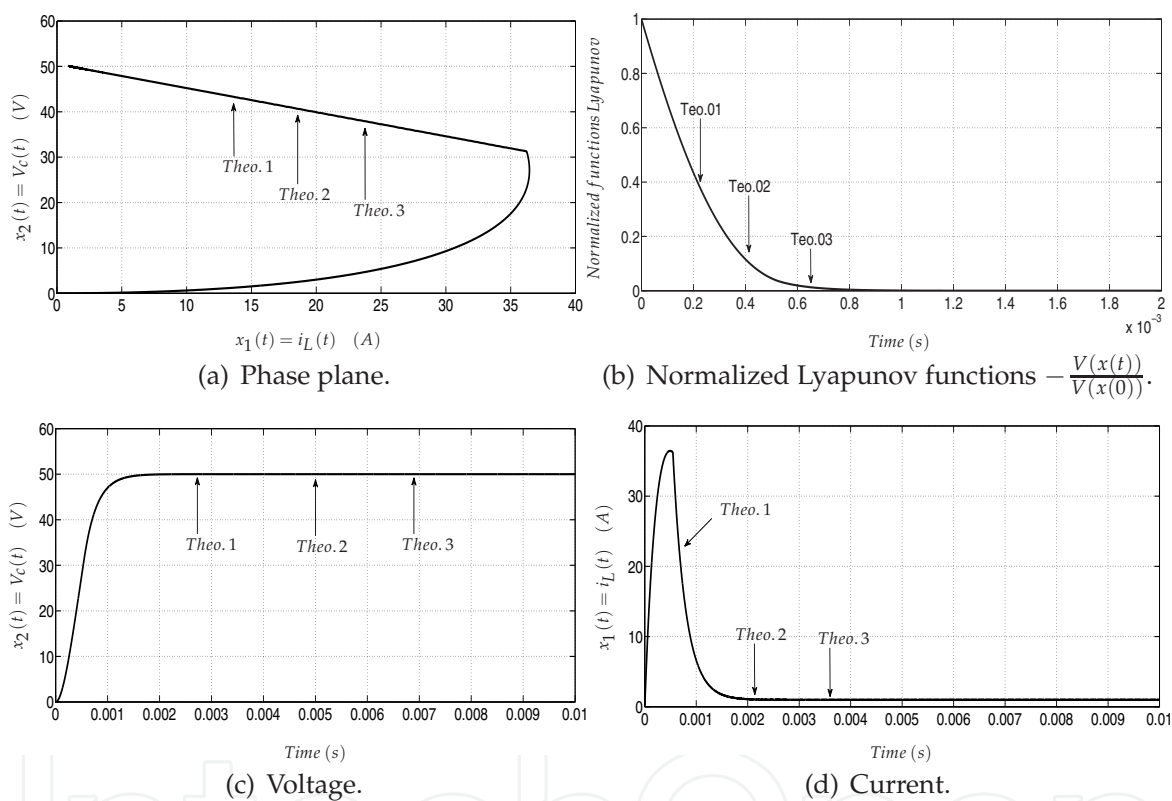

Fig. 2. Buck dynamic.

Observe that Theorem 3 presented the same convergence rate and cost by applying Theorems 1 and 2. This effect is due to the fact that for this particular converter, the gradient of the switching surface does not depend on the equilibrium point (Deaecto et al., 2010). Table 1 presents the obtained results.

	Overshoot [A]	Time [ms]	Cost (6)
Theo. 1	36.5	2	0.029
Theo. 2	36.5	2	0.029
Theo. 3	36.5	2	0.029

Table 1. Buck results.

3.2 Boost converter

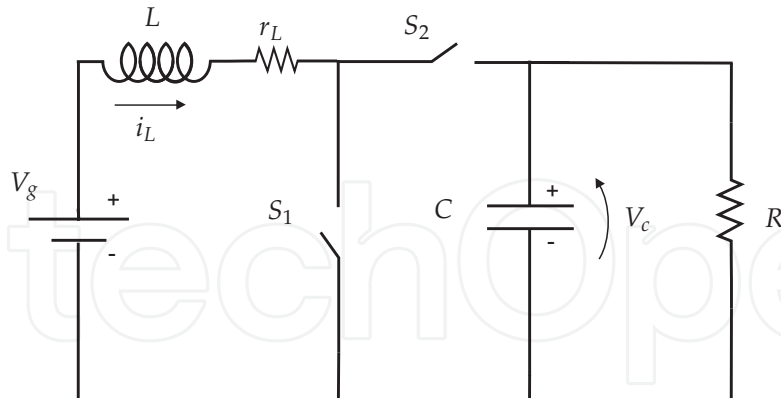

Fig. 3. Boost DC-DC converter.

In order to compare the results from the previous theorems, designs and simulations will be also done for a DC-DC converter, Boost. The converter is modeled with a parasitic resistor in series with the inductor. The switched system state-space (1) is defined by the following matrices (Deaecto et al., 2010):

$$A_1 = \begin{bmatrix} -r_L/L & 0 \\ 0 & -1/RC \end{bmatrix}, \quad A_2 = \begin{bmatrix} -r_L/L & -1/L \\ 1/C & -1/RC \end{bmatrix},$$

$$B_1 = \begin{bmatrix} 1/L \\ 0 \end{bmatrix}, \quad B_2 = \begin{bmatrix} 1/L \\ 0 \end{bmatrix}. \quad (33)$$

In this example, $\lambda_1 = 0.4$ and $\lambda_2 = 0.6$. Using the minimization problems (11) of Theorem 1 and (15) of Theorem 2, the matrices of the quadratic Lyapunov functions are

$$P = 1 \times 10^{-4} \begin{bmatrix} 0.0237 & 0.0742 \\ 0.0742 & 0.2573 \end{bmatrix}, \quad P = 1 \times 10^{-3} \begin{bmatrix} 0.1450 & 0.0088 \\ 0.0088 & 0.2478 \end{bmatrix},$$

respectively. Now, from minimization problem of Theorem 3, we found the matrices below as a solution, and from (10) the guaranteed cost $J < (x_0 - x_r)'P(x_0 - x_r) = 0.59$:

$$P = 1 \times 10^{-4} \begin{bmatrix} 0.0237 & 0.0742 \\ 0.0742 & 0.2573 \end{bmatrix},$$

$$N_1 = \begin{bmatrix} -0.018 & -0.030 \\ -0.030 & 0.0178 \end{bmatrix}, \quad N_2 = \begin{bmatrix} 0.012 & 0.020 \\ 0.020 & -0.012 \end{bmatrix}.$$

The initial condition is the origin and the equilibrium point is $x_r = [5 \ 150]'$. The results are illustrated in Figure 4 and Table 2 presents the obtained results.

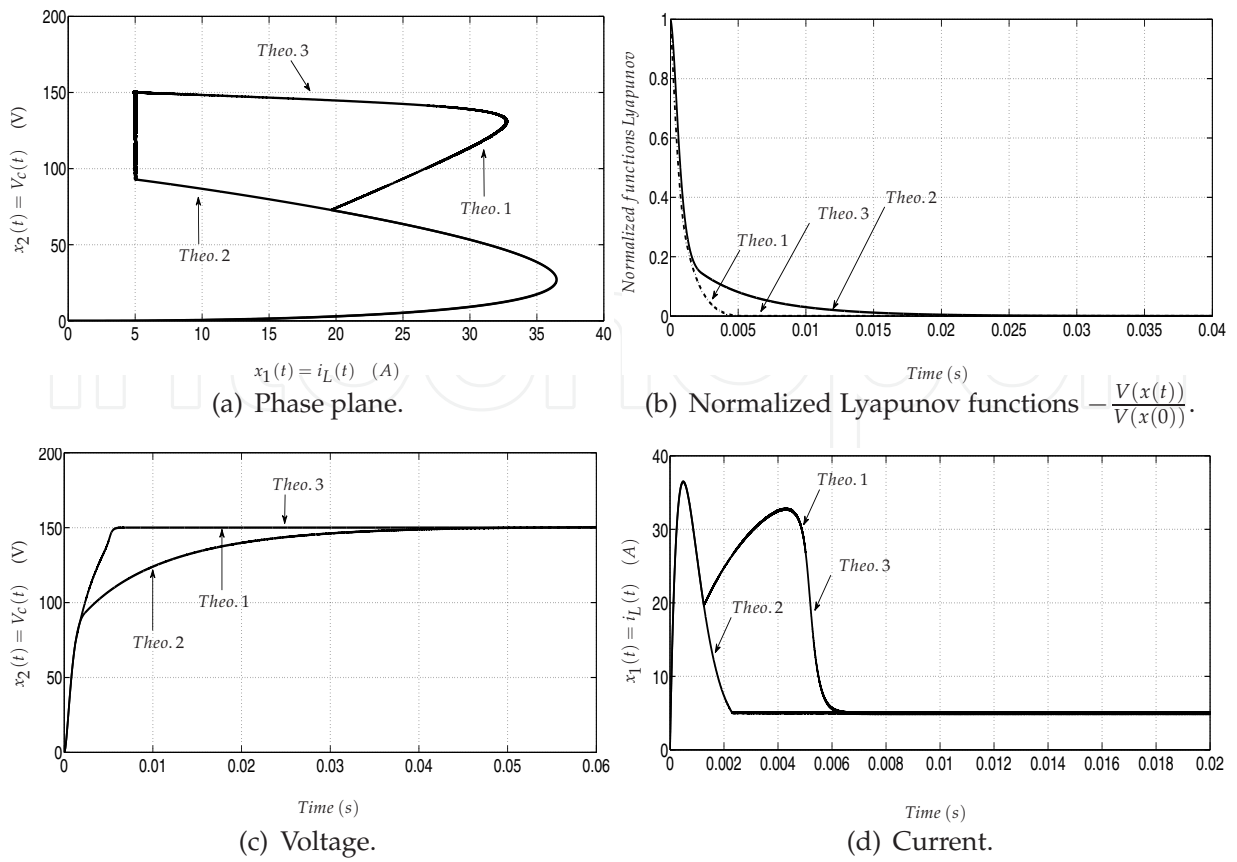

Fig. 4. Boost dynamic.

	Overshoot [A]	Time [ms]	Cost (6)
Theo. 1	36.5	7	0.59
Theo. 2	36.5	40	5.59
Theo. 3	36.5	7	0.59

Table 2. Boost results.

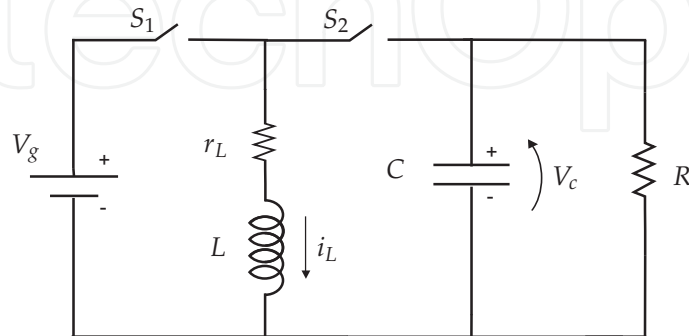

Fig. 5. Buck-Boost DC-DC converter.

3.3 Buck-Boost converter

Figure 5 shows the structure of the Buck-Boost converter. The switched system state-space (1) is defined by the following matrices (Deaecto et al., 2010):

$$A_1 = \begin{bmatrix} -r_L/L & 0 \\ 0 & -1/RC \end{bmatrix}, \quad A_2 = \begin{bmatrix} -r_L/L & -1/L \\ 1/C & -1/RC \end{bmatrix},$$

$$B_1 = \begin{bmatrix} 1/L \\ 0 \end{bmatrix}, \quad B_2 = \begin{bmatrix} 0 \\ 0 \end{bmatrix}. \quad (34)$$

The initial condition was the origin $x = [i_L \ V_c]' = [0 \ 0]'$, $\lambda_1 = 0.6$, $\lambda_2 = 0.4$ and the equilibrium point is equal to $x_r = [6 \ 120]'$. Moreover, the optimal solutions of minimization problems (11) of Theorem 1 and (15) of Theorem 2, are

$$P = 1 \times 10^{-4} \begin{bmatrix} 0.0211 & 0.0989 \\ 0.0989 & 0.4898 \end{bmatrix}, \quad P = 1 \times 10^{-3} \begin{bmatrix} 0.1450 & 0.0088 \\ 0.0088 & 0.2478 \end{bmatrix},$$

respectively. Maintaining the same parameters, the optimal solution of minimization problem (21) are the matrices below and from (10) the guaranteed cost $J < (x_0 - x_r)'P(x_0 - x_r) = 0.72$:

$$P = 1 \times 10^{-4} \begin{bmatrix} 0.0211 & 0.0990 \\ 0.0990 & 0.4898 \end{bmatrix},$$

$$N_1 = \begin{bmatrix} -0.0168 & -0.0400 \\ -0.0400 & 0.0158 \end{bmatrix}, \quad N_2 = \begin{bmatrix} 0.0253 & 0.0600 \\ 0.0600 & -0.0237 \end{bmatrix}.$$

The results are illustrated in Figure 6. Table 3 presents the obtained results. The next section

	Overshoot [A]	Time [ms]	Cost (6)
Theo. 1	37.5	10	0.72
Theo. 2	7.5	70	3.59
Theo. 3	37.5	10	0.72

Table 3. Buck-Boost results.

is devoted to extend the theoretical results obtained in Theorems 1 (Deaecto et al., 2010) and 2 (Deaecto et al., 2010) for the model Sepic DC-DC converter.

4. Sepic DC-DC converter

A Sepic converter (Single-Ended Primary Inductor Converter) is characterized by being able to operate as a step-up or step-down, without suffering from the problem of polarity reversal. The Sepic converter consists of an active power switch, a diode, two inductors and two capacitors and thus it is a nonlinear fourth order. The converter is modeled with parasitic resistances in series with the inductors. The switched system (1) is described by the following matrices:

$$A_1 = \begin{bmatrix} -r_{L1}/L_1 & 0 & 0 & 0 \\ 0 & -r_{L2}/L_2 & -1/L_2 & 0 \\ 0 & 1/C_1 & 0 & 0 \\ 0 & 0 & 0 & -1/(RC_2) \end{bmatrix}, \quad B_1 = \begin{bmatrix} 1/L_1 \\ 0 \\ 0 \\ 0 \end{bmatrix},$$

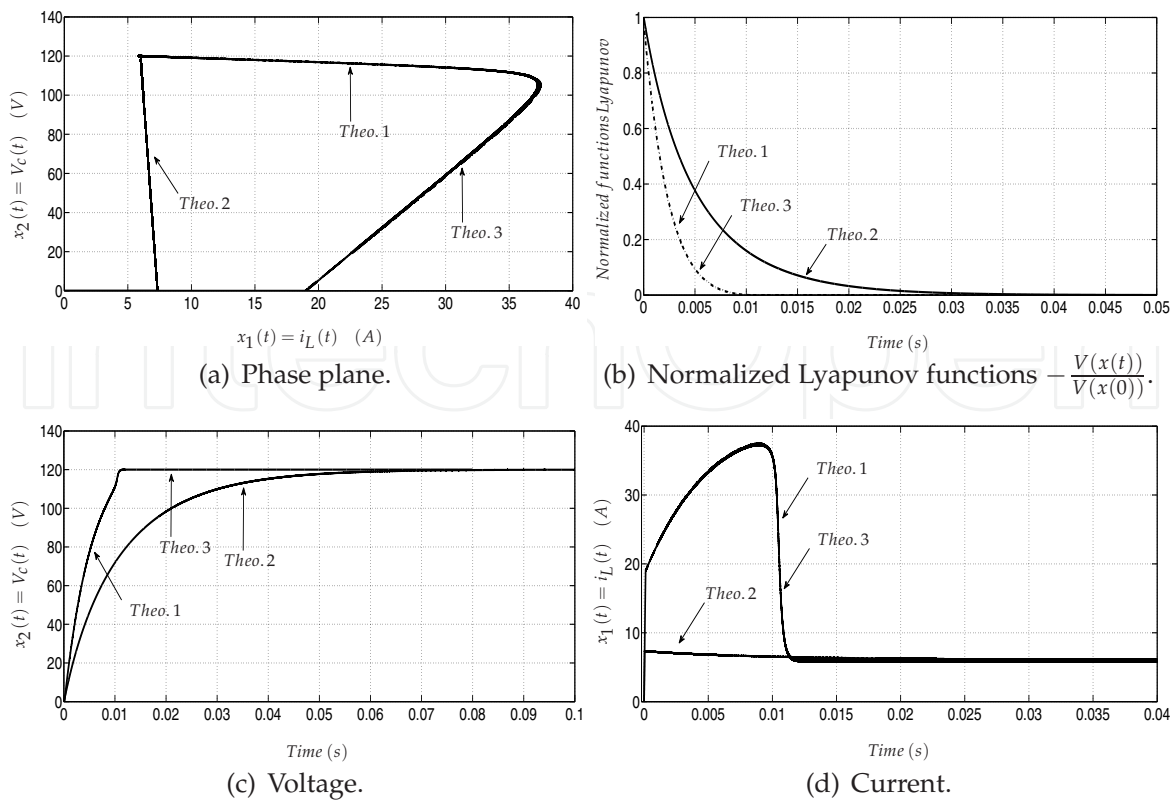

Fig. 6. Buck-Boost dynamic.

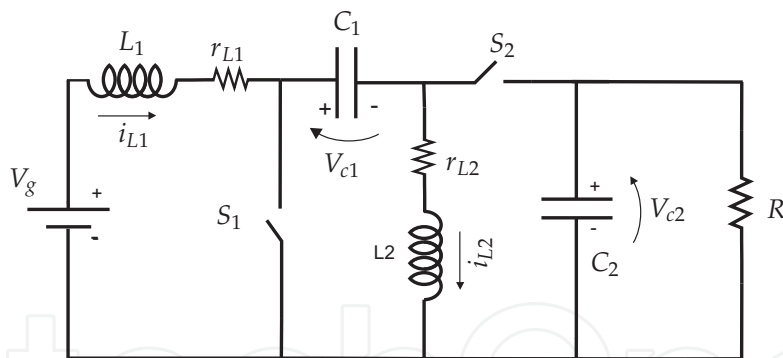

Fig. 7. Sepic DC-DC converter.

$$A_2 = \begin{bmatrix} -r_{L1}/L_1 & 0 & -1/L_1 & -1/L_1 \\ 0 & -r_{L2}/L_2 & 0 & 1/L_2 \\ 1/C_1 & 0 & 0 & 0 \\ 1/C_2 & -1/C_2 & 0 & -1/(RC_2) \end{bmatrix}, \quad B_2 = \begin{bmatrix} 1/L_1 \\ 0 \\ 0 \\ 0 \end{bmatrix}. \quad (35)$$

For this converter, consider that $i_{L1}(t), i_{L2}(t)$ denote the inductors currents and $V_{c1}(t), V_{c2}(t)$ the capacitors voltages, that again were adopted as state variables of the system:

$$x(t) = [x_1(t) \ x_2(t) \ x_3(t) \ x_4(t)]' = [i_{L1}(t) \ i_{L2}(t) \ V_{c1}(t) \ V_{c2}(t)]'. \quad (36)$$

Adopt the following operating point,

$$x_r = [x_{1r}(t) \ x_{2r}(t) \ x_{3r}(t) \ x_{4r}(t)]' = [i_{L1r}(t) \ i_{L2r}(t) \ V_{c1r}(t) \ V_{c2r}(t)]'. \quad (37)$$

The DC-DC converter operates in continuous conduction mode. The used solver was the LMILab from the software MATLAB interfaced by YALMIP (Lofberg, 2004). The parameters are the following: $V_g = 100[V]$, $R = 50[\Omega]$, $r_{L1} = 2[\Omega]$, $r_{L2} = 3[\Omega]$, $L_1 = 500[\mu H]$, $L_2 = 600[\mu H]$, $C_1 = 800[\mu F]$, $C_2 = 470[\mu F]$ and

$$Q_i = Q = \begin{bmatrix} \rho_1 r_{L1} & 0 & 0 & 0 \\ 0 & \rho_2 r_{L2} & 0 & 0 \\ 0 & 0 & 0 & 0 \\ 0 & 0 & 0 & \rho_3/R \end{bmatrix}, \quad (38)$$

is the performance index matrix associated with the guaranteed cost

$$\int_0^{\infty} (\rho_1 r_{L1} (i_{L1} - i_{L1r})^2 + \rho_2 r_{L2} (i_{L2} - i_{L2r})^2 + \rho_3 R^{-1} (V_{c2} - V_{c2r})^2) dt, \quad (39)$$

where $\rho_i \in \mathbb{R}_+$ are design parameters. Before of all, the set of all attainable equilibrium point is calculated considering that

$$x_r = \{[i_{L1r} \ i_{L2r} \ V_{c1r} \ V_{c2r}]' : V_{c1r} = V_g, \ 0 \leq V_{c2r} \leq R i_{L2r}\}. \quad (40)$$

The initial condition was the origin $x = [i_{L1} \ i_{L2} \ V_{c1} \ V_{c2}]' = [0 \ 0 \ 0 \ 0]'$. Figure 8 shows the phase plane of the Sepic converter corresponding to the following values of load voltage $V_{c2r} = \{50, 60, \dots, 150\}$.

In this case, Theorem 1 presented a voltage setting time smaller than $30[ms]$ and the maximum current peak $i_{L1} = 34[A]$ and $i_{L2} = 9[A]$. However, Theorem 2 showed a voltage setting time smaller than $80[ms]$, with currents peaks $i_{L1} = 34[A]$ and $i_{L2} = 13.5[A]$. Now, in order to compare the results from the proposed Theorem 3, adopt origin as initial condition, $\lambda_1 = 0.636$, $\lambda_2 = 0.364$ and the equilibrium point equal to $x_r = [5.24 \ -3 \ 100 \ 150]'$. From the optimal solutions of minimization problems (11) and (15), we obtain respectively

$$P = 1 \times 10^{-4} \begin{bmatrix} 0.0141 & -0.0105 & 0.0037 & 0.0707 \\ -0.0105 & 0.0078 & -0.0026 & -0.0533 \\ 0.0037 & -0.0026 & 0.0016 & 0.0172 \\ 0.0707 & -0.0533 & 0.0172 & 0.3805 \end{bmatrix},$$

$$P = 1 \times 10^{-3} \begin{bmatrix} 0.0960 & -0.0882 & 0.0016 & 0.0062 \\ -0.0882 & 0.0887 & 0.0184 & -0.0034 \\ 0.0016 & -0.0184 & 0.0940 & 0.0067 \\ 0.0062 & -0.0034 & 0.0067 & 0.2449 \end{bmatrix}.$$

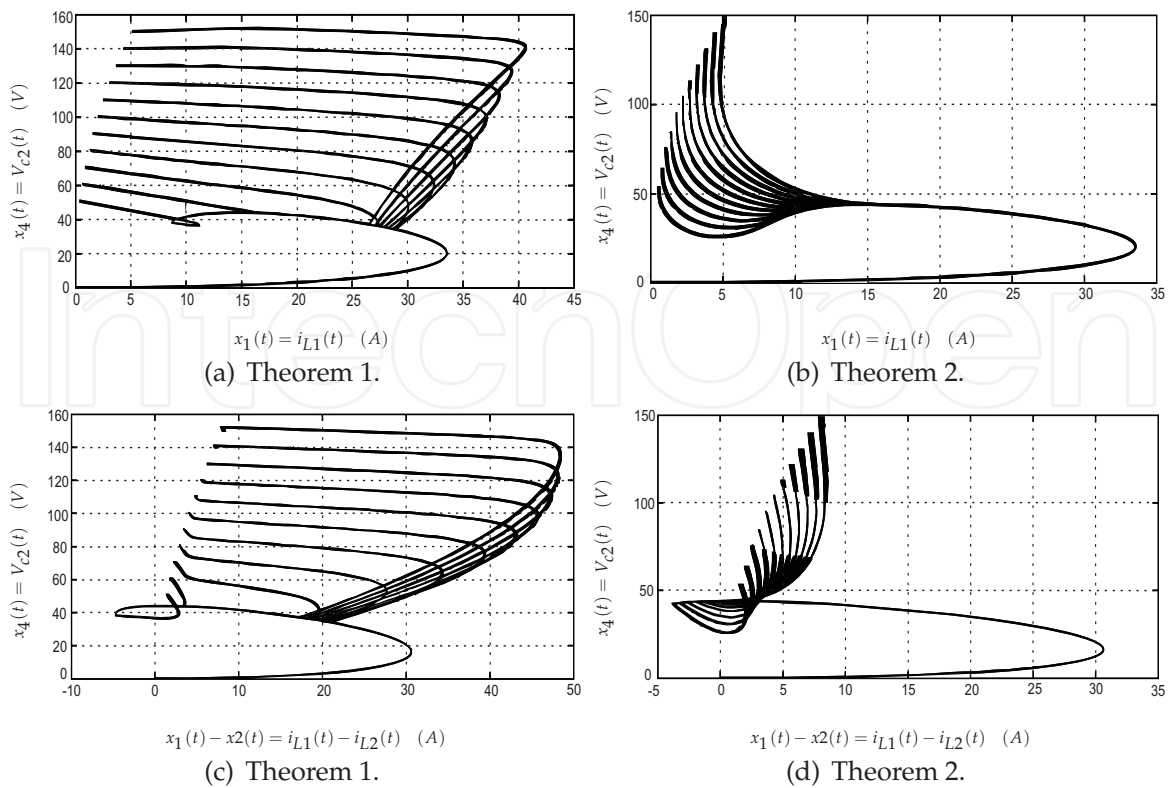

Fig. 8. Sepic DC-DC converter phase plane.

Maintaining the same parameters, the optimal solution of minimization problem (21) are the matrices below and from (10) the guaranteed cost $J < (x_0 - x_r)'P(x_0 - x_r) = 0.93$:

$$P = 1 \times 10^{-4} \begin{bmatrix} 0.0141 & -0.0105 & 0.0037 & 0.0707 \\ -0.0105 & 0.0078 & -0.0026 & -0.0533 \\ 0.0037 & -0.0026 & 0.0016 & 0.0172 \\ 0.0707 & -0.0533 & 0.0172 & 0.3805 \end{bmatrix},$$

$$N_1 = \begin{bmatrix} -0.0113 & 0.0099 & 0.0003 & -0.0286 \\ 0.0099 & -0.0085 & 0.0002 & 0.0290 \\ 0.0003 & 0.0002 & 0.0009 & 0.0088 \\ -0.0286 & 0.0290 & 0.0088 & 0.0168 \end{bmatrix},$$

$$N_2 = \begin{bmatrix} 0.0197 & -0.0173 & -0.0005 & 0.0500 \\ -0.0173 & 0.0148 & -0.0003 & -0.0507 \\ -0.0005 & -0.0003 & -0.0015 & -0.0154 \\ 0.0500 & -0.0507 & -0.0154 & -0.0293 \end{bmatrix}.$$

The results are illustrated in Figure 9 and Table 4 presents the obtained results from the simulations.

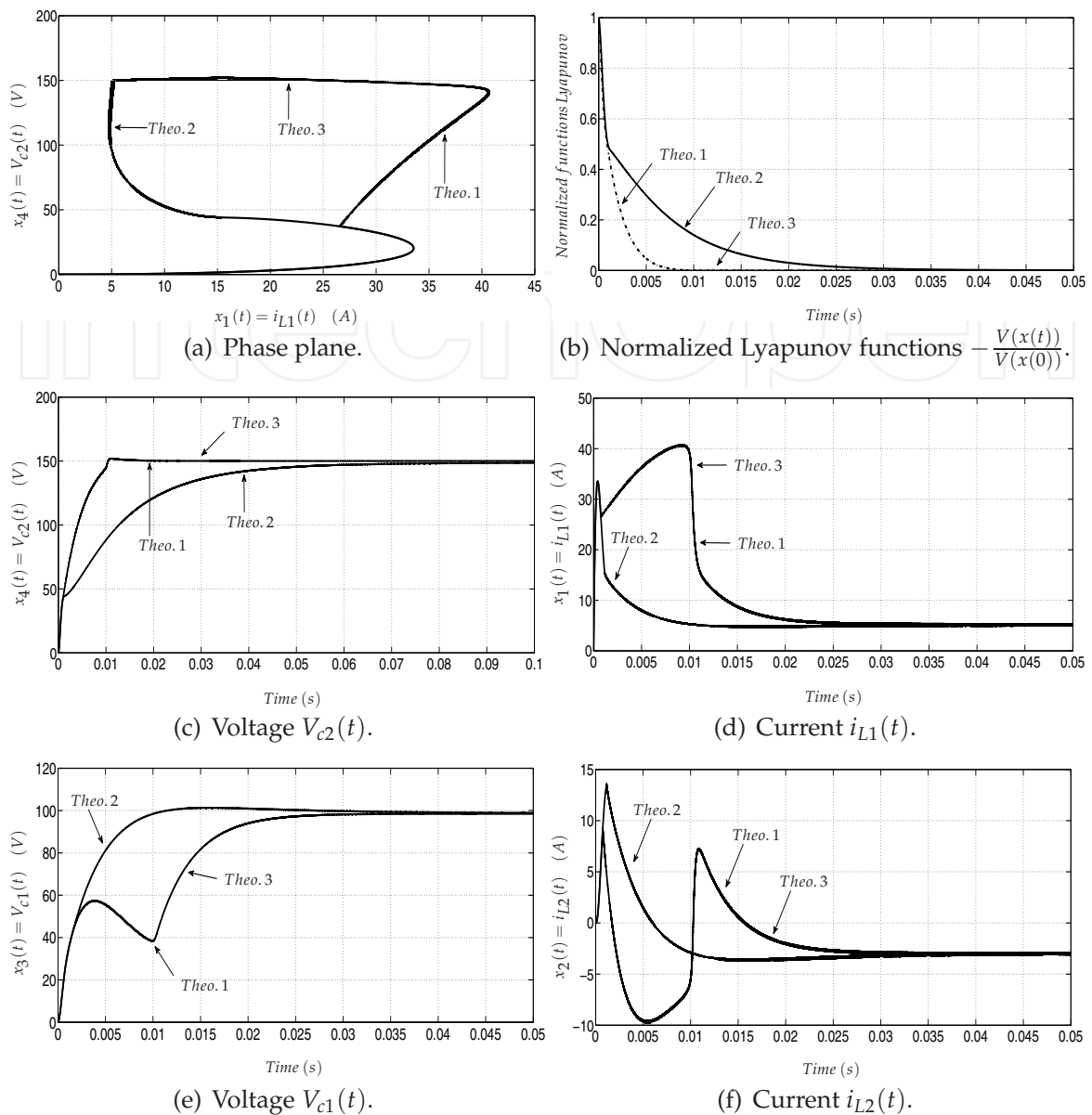

Fig. 9. Sepic dynamic.

	Overshoot [A]	Time [ms]	Cost (6)
Theo. 1	34	30	0.93
Theo. 2	34	80	6.66
Theo. 3	34	30	0.93

Table 4. Sepic results.

Remark 1. From the simulations results, note that the proposed Theorem 3 presented the same results obtained by applying Theorem 1. Theorem 3 is an interesting theoretical result, as described in Theorem 4, and the authors think that it can be useful in the design of more general switched controllers.

5. Conclusions

This paper presented a study about the stability and control design for switched affine systems. Theorems proposed in (Deaecto et al., 2010) and later modified to include bounds on output peak on the control project were presented. A new theorem for designing switching affine control systems, with a flexibility that generalises Theorems 1 and 2 from (Deaecto et al., 2010) was proposed. Finally, simulations involving four types of converters namely Buck, Boost, Buck-Boost and Sepic illustrate the simplicity, quality and usefulness of this design methodology. It was also the first time that this class of controller was used for controlling a Sepic converter, that is a fourth order system and so is more complicated than the switched control design of second order Buck, Boost and Buck-Boost converters (Deaecto et al., 2010).

6. Acknowledgement

The authors gratefully acknowledge the financial support by CAPES, FAPESP and CNPq from Brazil.

7. References

- Battle, C., Fossas, E. & Olivar, G. (1996). Stabilization of periodic orbits in variable structure systems. Application to DC-DC power converters, *International Journal of Bifurcation and Chaos*, v. 6, n. 12B, p. 2635–2643.
- Bolzern, P. & Spinelli, W. (2004). Quadratic stabilization of a switched affine system about a nonequilibrium point, *American Control Conference, 2004. Proceedings of the 2004*, v. 5, p. 3890–3895.
- Boyd, S., El Ghaoui, L., Feron, E. & Balakrishnan, V. (1994). *Linear Matrix Inequalities in Systems and Control Theory*, Studies in Applied Mathematics, v. 15, 2 nd., SIAM Studies in Applied Mathematics.
- Cardim, R., Teixeira, M. C. M., Assunção, E. & Covacic, M. R. (2009). Variable-structure control design of switched systems with an application to a DC-DC power converter, *IEEE Trans. Ind. Electronics*, v. 56, n. 9, p. 3505–3513.
- Cardim, R., Teixeira, M. C. M., Assunção, E., Covacic, M. R., Faria, F. A., Seixas, F. J. M. & Mainardi Júnior, E. I. (2011). Design and implementation of a DC-DC converter based on variable structure control of switched systems, *18th IFAC World Congress, 2011. Proceedings of the 2011*, v. 18, p. 11048–11054.
- Deaecto, G. S., Geromel, J. C., Garcia, F. S. & Pomilio, J. A. (2010). Switched affine systems control design with application to DC-DC converters, *IET Control Theory & Appl.*, v. 4, n. 7, p. 1201–1210.
- Decarlo, R. A., Branicky, M. S., Pettersson, S. & Lennartson, B. (2000). Perspectives and results on the stability and stabilizability of hybrid systems, *Proc. of the IEEE*, v. 88, n. 7, p. 1069–1082.
- Faria, F. A., Assunção, E., Teixeira, M. C. M., Cardim, R. & da Silva, N. A. P. (2009). Robust state-derivative pole placement LMI-based designs for linear systems, *International Journal of Control*, v. 82, n. 1, p. 1–12.
- Feron, E. (1996). Quadratic stabilizability of switched systems via state and output feedback, *Technical report CICSP- 468* (MIT)..
- Gahinet, P., Nemirovski, A., Laub, A. J. & Chilali, M. (1995). *LMI control toolbox - for use with MATLAB*.

- He, Y., Xu, W. & Cheng, Y. (2010). A novel scheme for sliding-mode control of DC-DC converters with a constant frequency based on the averaging model, *Journal of Power Electronics*, v. 10, n.1, p. 1–8.
- Ji, Z., Wang, L. & Xie, G. (2005). *Quadratic stabilization of switched systems*, v. 36, 7 edn, Taylor & Francis.
- Liberzon, D. (2003). *Switching in Systems and Control*, Systems & Control, Birkhuser.
- Liberzon, D. & Morse, A. S. (1999). *Basic problems in stability and design of switched systems*, v. 19, 5 edn, IEEE Constr. Syst. Mag.
- Lofberg, J. (2004). Yalmip : a toolbox for modeling and optimization in MATLAB, *Computer Aided Control Systems Design, 2004 IEEE International Symposium on*, p. 284 –289.
- Mazumder, S. K., Nayfeh, A. H. & Borojevic, D. (2002). Robust control of parallel DC-DC buck converters by combining integral-variable-structure and multiple-sliding-surface control schemes, *IEEE Trans. on Power Electron.*, v. 17, n. 3, p. 428–437.
- Peaucelle, D., Henrion, D., Labit, Y. & Taitz, K. (2002). User's guide for sedumi interface 1.04.
- Skafidas, E., Evans, R. J., Savkin, A. V. & Petersen, I. R. (1999). Stability results for switched controller systems, *Automatica*, v. 35, p. 553–564.
- Sun, Z. & Ge, S. S. (2005). *Switched Linear Systems: Control and Design*, Springer, London.
- Teixeira, M. C. M., Assunção, E. & Avellar, R. G. (2003). On relaxed LMI-based designs for fuzzy regulators and fuzzy observers, *IEEE Trans. Fuzzy Syst.* v. 11, n. 5, p. 613 – 623.
- Teixeira, M. C. M., Covacic, M. R. & Assuncao, E. (2006). Design of SPR systems with dynamic compensators and output variable structure control, *Int. Workshop Var. Structure Syst.*, p. 328 –333.
- Xu, X., Zhai, G. & He, S. (2008). On practical asymptotic stabilizability of switched affine systems, *Nonlinear Analysis: Hybrid Systems* v. 2, p. 196–208.
- Yoshimura, V. L., Assunção, E., Teixeira, M. C. M. & Mainardi Júnior, E. I. (2011). A comparison of performance indexes in DC-DC converters under different stabilizing state-dependent switching laws, *Power Electronics Conference (COBEP), 2011 Brazilian*, p. 1069 –1075.

© 2012 The Author(s). Licensee IntechOpen. This is an open access article distributed under the terms of the [Creative Commons Attribution 3.0 License](#), which permits unrestricted use, distribution, and reproduction in any medium, provided the original work is properly cited.

IntechOpen

IntechOpen