

We are IntechOpen, the world's leading publisher of Open Access books Built by scientists, for scientists

4,800

Open access books available

122,000

International authors and editors

135M

Downloads

Our authors are among the

154

Countries delivered to

TOP 1%

most cited scientists

12.2%

Contributors from top 500 universities

**WEB OF SCIENCE™**Selection of our books indexed in the Book Citation Index
in Web of Science™ Core Collection (BKCI)

Interested in publishing with us?
Contact book.department@intechopen.com

Numbers displayed above are based on latest data collected.

For more information visit www.intechopen.com

Fabrication, Purification and Characterization of Carbon Nanotubes: Arc-Discharge in Liquid Media (ADLM)

Mohsen Jahanshahi and Asieh Dehghani Kiadehi

Additional information is available at the end of the chapter

<http://dx.doi.org/10.5772/51116>

1. Introduction

Carbon nanotubes (CNTs) were first discovered by Iijima in 1991 [1]. CNTs have sparked great interest in many scientific fields such as physics, chemistry, and electrical engineering [2, 3]. CNTs are composed of graphene sheets rolled into closed concentric cylinders with diameter of the order of nanometers and length of micrometers. CNTs are in two kinds, based on number of walls, the single-walled and multi-walled.

The diameter of single walled carbon nanotubes (SWNTs) ranges from 0.4 nm to 3nm and the length can be more than 10 mm that makes SWNTs good experimental templates to study one-dimensional mesoscopic physics system [3]. These unique properties have been the engines of the rapid development in scientific studies in carbon based mesoscopic physics and numerous applications such as high performance field effect transistors [4-9], single-electron transistors [10, 11], atomic force microscope tips [12], field emitters [13, 14], chemical/biochemical sensors [15-18], hydrogen storage [19].

There are three important methods to produce high quality CNT namely laser [20], arc discharge [21, 22], and Chemical Vapor Deposition (CVD) [23, 24]. Recently, arc discharge in liquid media has been developed to synthesize several types of nano-carbon structures such as: carbon onions, carbon nanohorns and carbon nanotubes. This is a low cost technique as it does not require expensive apparatus [25,26].

However, several techniques such as oxidation, nitric acid reflux, HCl reflux, organic functionalization, filtration, mechanical purification and chromatographic purification have been developed that separate the amorphous carbons and catalyst nanoparticles from the CNTs while a significant amount of CNTs are also destroyed during these purification processes [27].

In this review paper, synthesis, purification and structural characterization of CNTs based on arc discharge in liquid media are reviewed and discussed. In addition, several parameters such as: voltage difference between electrodes, current, type and ratio of catalysts, electrical conductivity, concentration, type and temperature of plasma solution, as well as thermal conductivity on carbon nanotubes production are investigated.

2. Synthesis of CNTs

2.1. Laser vaporization

The laser vaporization method was developed for CNT production by Smalley's group [28, 29]. The laser is suitable for materials with high boiling temperature elements such as carbon because of its high energy density. The quantities of CNTs, in this method are large. Smalley's group further developed the laser method also known as the laser-furnace method [28]. Fullerenes with a soccer ball structure are produced only at high furnace temperatures, underlining the importance of annealing for nanostructures [28]. These discoveries were applied to produce CNTs [29] in 1996, especially SWNTs. A beam of high power laser impinges on a graphite target sitting in a furnace at high temperature as Figure 1 shows.

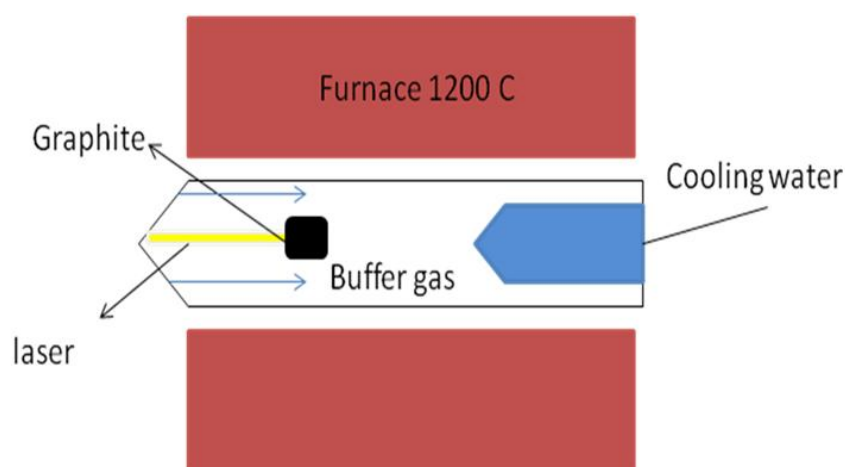

Figure 1. Schematic drawing of a laser obtain.

The target is vaporized in high-temperature buffer gas like Ar and formed CNTs. The produced CNTs are conveyed by the buffer gas to the trap, where they are collected. Then CNTs can be found in the soot at cold end.

This method has several advantages, such as high-quality CNTs production, diameter control, investigation of growth dynamics, and the production of new materials. High-quality CNTs with minimal defects and contaminants, such as amorphous carbon and catalytic metals, have been produced using the laser-furnace method together with purification processes [30-32] but the laser has sufficiently high energy density to vaporize target at the molecular level. The graphite vapor is converted into amorphous carbon as the starting material of

CNTs [33-35]. However, the laser technique is not economically advantageous, since the process involves high purity graphite rods, high power lasers and low yield of CNTs.

2.2. Chemical vapor deposition (CVD)

The chemical vapor deposition (CVD) is another method for producing CNTs in which a hydrocarbon vapor is thermally decomposed in the presence of a metal catalyst. In this method, carbon source is placed in gas phase in reaction chamber as shown in Figure 2. The synthesis is achieved by breaking the gaseous carbon molecules, such as methane, carbon monoxide and acetylene, into reactive atomic carbon in a high temperature furnace and sometime helped by plasma to enhance the generation of atomic carbon [36].

This carbon will get diffused towards substrate, which is coated with catalyst and nanotubes grow over this metal catalyst. Temperature used for synthesis of nanotube is 650 – 900 °C range and the typical yield is 30% [36].

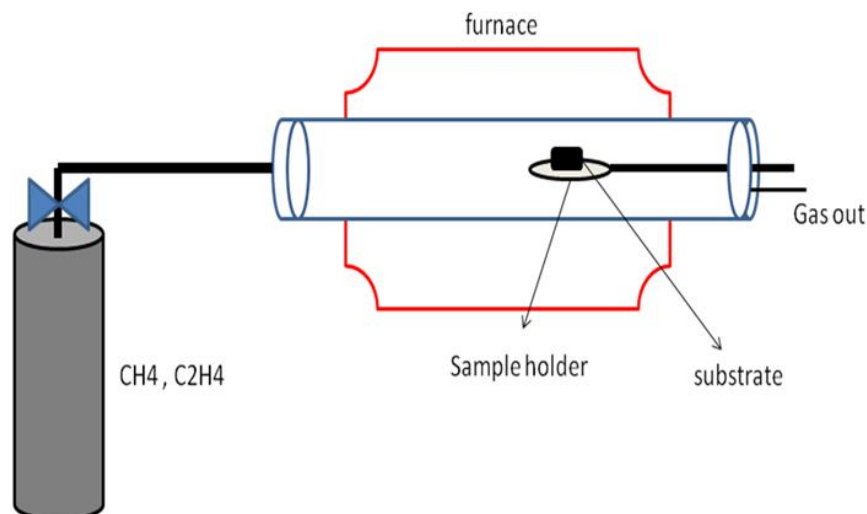

Figure 2. Schematic diagram of a CVD setup.

In fact, CVD has been used for producing [37-39] carbon filaments and fibers since 1959. Figure 2 shows a schematic diagram of the setup used for CNT growth by CVD in its simplest form. CNTs grow over the catalyst and are collected upon cooling the system to room temperature. The catalyst material may be different, solid, liquid, or gas and can be placed inside the furnace or fed in from outside [40, 41].

2.3. Arc Discharge

A schematic diagram of the arc discharge apparatus for producing CNTs is shown in Figure 3. In this method, two graphite electrodes are installed vertically, and the distance between the two rod tips is usually in the range of 1–2 mm. The anode and cathode are made of pure graphite (those are, with a purity of 99.999%).

The anode is drilled, and the hole is filled with catalyst metal powder then the chamber is connected to a vacuum line with a diffusion pump and to a gas supply [43]. Like the anode in a DC electric arc discharge reactor, CNT is synthesized of graphite rod. After the evacuation of the chamber by a diffusion pump, rarefied ambient gas is introduced [43].

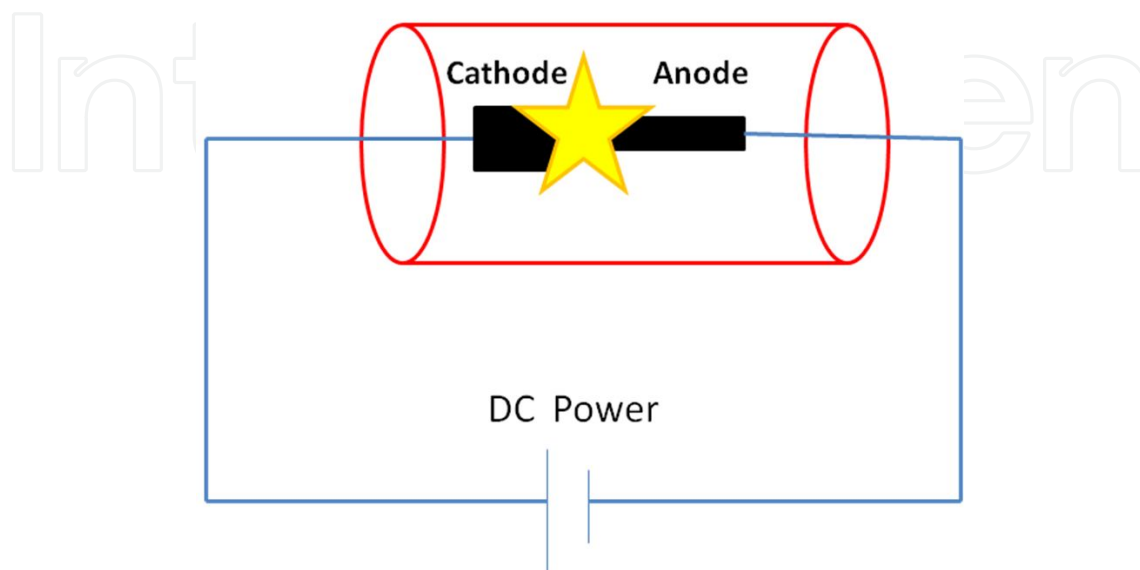

Figure 3. Schematic diagram of apparatus for preparing CNTs.

When a dc arc discharge is applied between the two graphite rods, the anode is consumed, and fullerene is formed in the chamber soot [43]. The mass production of multi wall carbon nanotubes (MWCNTs) by this dc arc discharge evaporation was first achieved by Ebbesen and Ajayan [44].

3. Arc-Discharge in Liquid Media (ADLM)

The traditional arc-plasma growth method for CNTs necessitates complex gas-handling equipment, a sealed reaction chamber, a liquid-cooled system and time consuming purge cycles. The act of extraction of nanotube's product is so complicated [45]. To be compared, the growth of arc plasma in water requires simple operation and equipment which had made the process of CNTs production noticeable [47].

Ishigami et al. [48] developed a simple arc method in liquid nitrogen for the first time that allow for the continuous synthesis of high-quality CNTs. The materials obtained are mainly MWCNTs, amorphous carbon, graphitic particles and carbonaceous material [48, 49]. Subsequently, an aqueous arc-discharge (arc-water) method was developed. Lange et al. [50] generated onions, nanotubes and encapsulates by arc discharge in water. Figure 4 is shown produced CNTs in LiCl 0.25 N media [51].

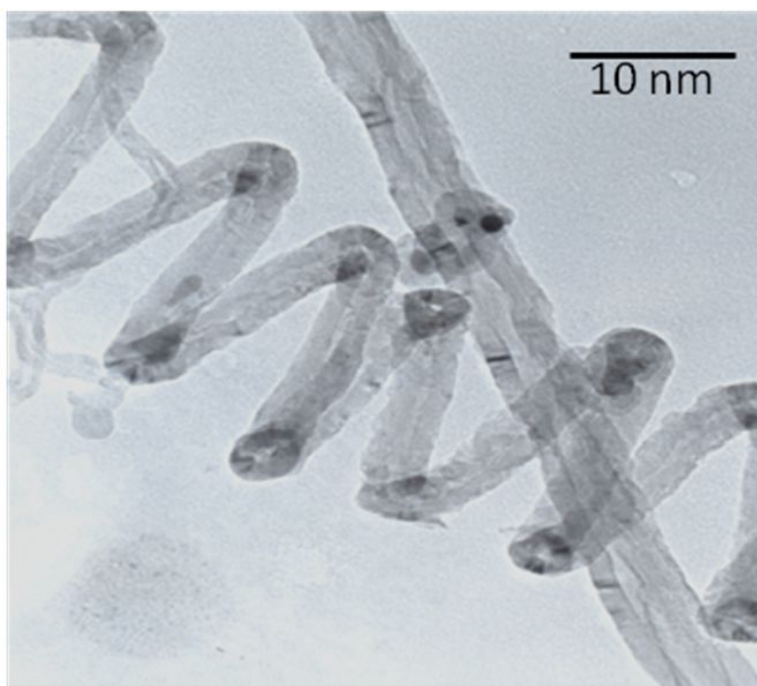

Figure 4. Carbon nanotubes produced in LiCl 0.25 N [51].

The arc discharge in liquid is initiated between two high purity graphite electrodes. Figure 5 is shown schematic device of arc discharge in liquid. Both electrodes are submerged in the liquid in a beaker. At first, the electrodes touch each other and are connected with a direct current (DC) power supply.

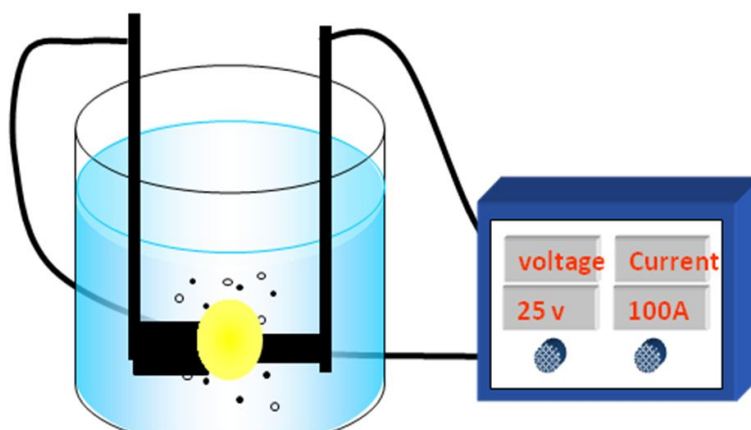

Figure 5. Schematic device of arc discharge in liquid.

The cathode is usually 20 mm in diameter, while the anode is 6 mm in diameter. Then the arc discharge is initiated by slowly detaching the moveable anode from the cathode. The arc gap is kept at the proper value (about 1 mm) that the continuous arc discharge could be obtained [52].

Recently carbon nanotubes (CNTs) were fabricated successfully with arc discharge in solution by a novel full automatic set up [51].

The arc discharge and consequently consumption of anode result to increase the distance between the two electrodes and degrades the voltage between them as well. In order to remain constant voltage and gap between the two electrodes, the program automatically will compare the initial voltage with the voltage of two electrodes with an accuracy of 0.1 V. Based on the calculated difference the program calculates the proportional coefficient for the proportional controller. Figure 6 is schematic of the apparatus used for automatic arc discharge in solution [51].

During the arc discharge, the gap between the two electrodes is maintained at approximately 1 mm, while the synthesis time is 60 s [51].

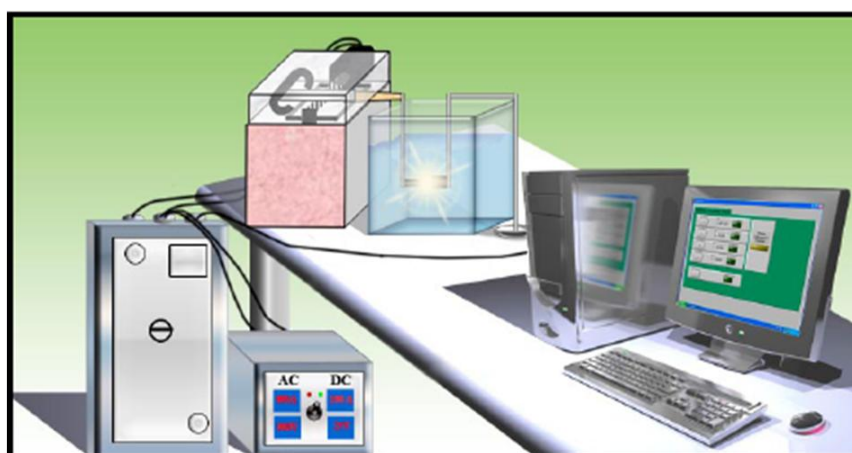

Figure 6. Schematic of the apparatus used for automatic arc discharge in solution [51].

3.1. Catalyst Materials and their ratio

A metal catalyst is necessary for the growth of the CNTs in all the methods used for synthesis of CNTs. Catalysts use to prepare CNTs usually include transition metals as a single or mixture of two catalysts such as a single, Fe, Co, Ni or Mo [53] or mixture of two catalysts such as FeNi [54], PtRh [55] and NiY [22]. Hsin et al. [57] firstly reported the production of metal-containing CNTs by arc discharge in solution.

The catalyst activation is determined in relation to the melting temperature and the boiling temperature thus the melting and boiling temperature of a catalyst can be one of the vital factors in the synthesis of SWCNTs [51].

CNTs are synthesized while the anode is filled by divergent single or bimetallic catalysts [51]. Scanning electron microscopies (SEM) show that the fabricated CNTs without any catalyst, figure 7, is in a very short long, disordered and is faulty grown.

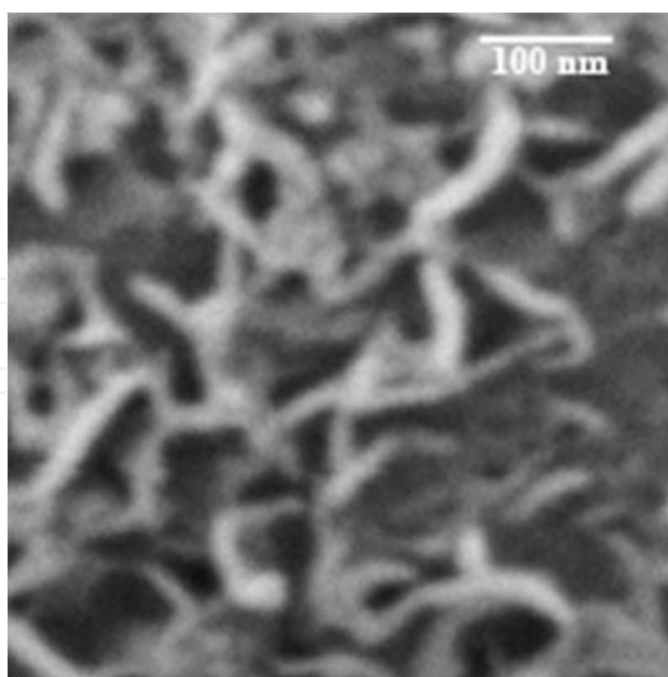

Figure 7. SEM image of the product which was fabricated without catalyst [51]

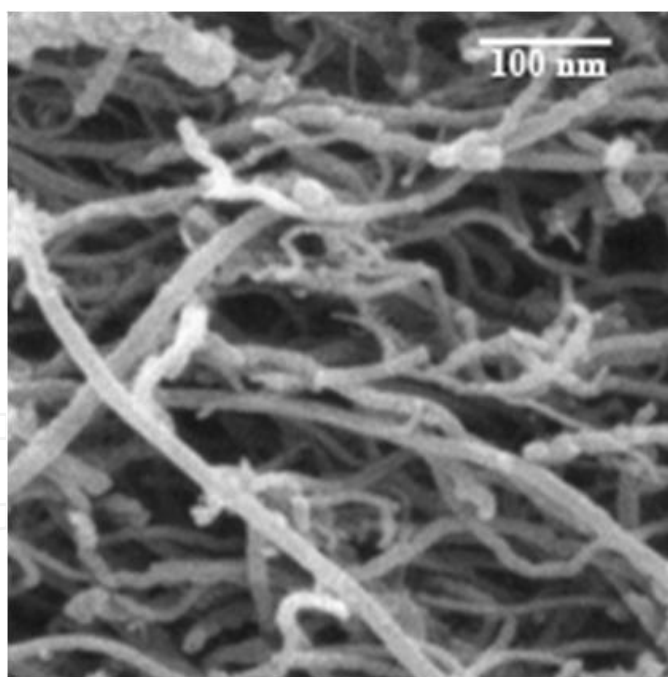

Figure 8. SEM image of the product which is fabricated with 5% Ni as catalyst [51].

Ni catalyst, figure 8, motivate a production of elongated CNTs and springy CNTs with a relatively good yield while Fe catalysts, figure 9, promote a production of CNTs with short length and defect structure and the yield is moderate.

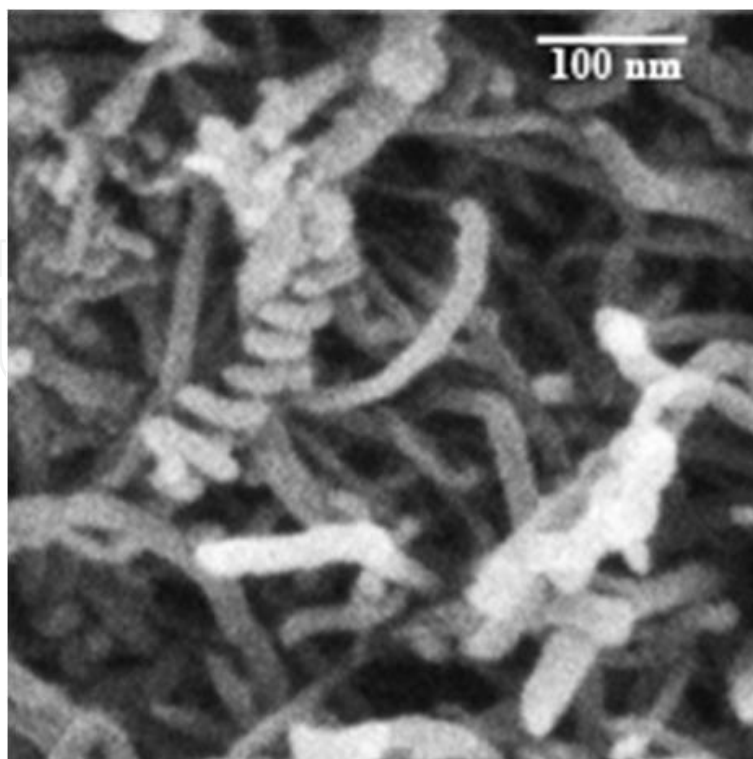

Figure 9. SEM image of the product which was fabricated with 5% Fe as catalyst [51].

Jahanshahi et al. showed that Mo catalysts motivate a production of CNTs with long length and high crystalline structure but with a wide diameter while it has a relatively good yield. In contrast, Mo-Ni bimetallic catalyst cause the production of CNTs with long length, narrow distribution diameters and crystalline structure without any defect and follow with a good yield [51].

3.2. Plasma Solution Temperature

The effect of solution temperature on the synthesis of CNTs and the structure of fabricated CNTs was investigated by Dehghani et al [57]. Scanning electron microscopes and transient electron microscopes (TEMs), figure 10, shows that the fabricated CNTs below zero as thermal condition is not suitable for synthesizing CNTs by the arc discharge method in liquid and CNTs cannot grow under low temperatures, especially below zero. High temperature is also not suitable for synthesizing CNTs by the arc discharge method in liquid media.

In contrast, observations show that in the environment with (25 °C) temperature, long CNTs are formed with narrow distribution diameter, complete clean, flat surface and arranged structure. Constant temperature around 25°C is the best thermal condition for synthesizing CNTs by the arc discharge method in liquid [57].

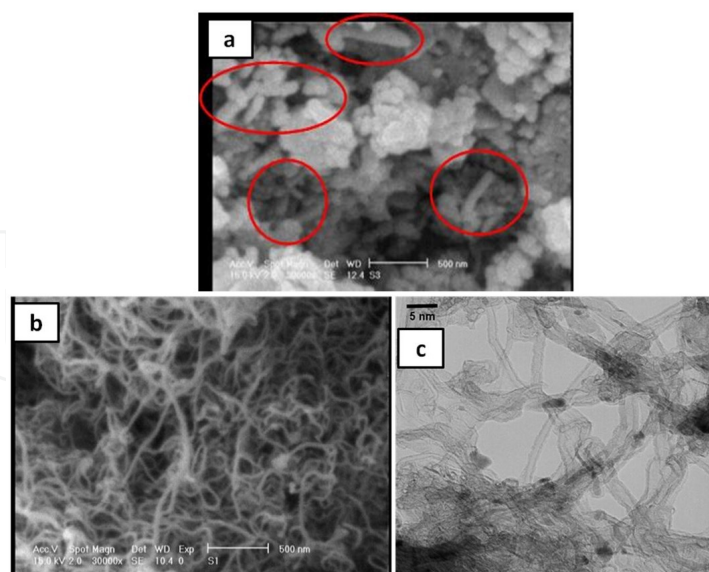

Figure 10. SEM image of the product which was fabricated a) below zero temperature b) at a high temperature (80°C), c) at the environment temperature (25 °C)[57].

3.3. Voltage difference between electrodes

The voltage effects on the production of the nanostructures by applying a variety of voltage values in different experiments were investigated by Jahanshahi et al [58]. The SEMs of the synthesized materials, figure 11 shows the formation of fullerene at a voltage of 10 V, while both CNTs and fullerenes are fabricated at a voltage of 20 V.

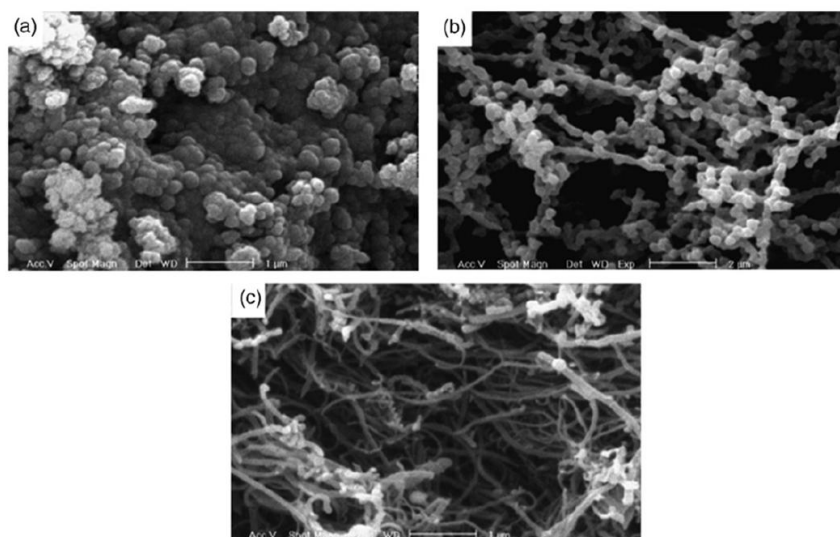

Figure 11. a) SEM images of the produced sample by arc discharge at a voltage of 10 V. (b) SEM images of the produced sample by arc discharge at a voltage of 20 V. (c) SEM images of the produced sample by arc discharge at a voltage of 30 V [58].

On the contrary, the elongated CNTs were synthesized with high quality at a voltage of 30 V. The results show that the rate of production efficiency and anode consumption is increased by increasing the voltage amount [58].

3.4. Plasma Solution Concentration

Liquid nitrogen provides a good environment for the MWCN synthesis, but the strong evaporation cause by the operation of the arc discharge does not allow a good thermal exchange between the synthesized material and its surroundings.

Arc discharge in deionised water and liquid nitrogen are erratic due to their electrical insulation [50]. The electrical conductivity of LiCl solution is also better than deionised water and liquid nitrogen [59].

Figure 12 shows TEM image of the as-grown MWCN synthesized in LiCl. Investigators have demonstrated the possibility of producing carbon nanostructures in the liquid phase (water, hydrocarbons, dichloromethane, CCl_4 , in liquid gases) [61].



Figure 12. TEM image of the as-grown MWCN synthesized in LiCl [58].

In contrast, liquid water besides providing a suitable environment also provides the thermal conditions necessary to retain good quality CNTs in the raw material, while the reactivity of the water with hot carbon does not appear to have any major effects on the reaction [59].

Figure 13 shows CNTs are produced in NaCl [62]. Nevertheless, arc discharge in NaCl solution is extremely stable owing to the excellent electrical conductivity induced by Cl^- and Na^+ ions. Too many Na^+ ions would hinder carbon ions flying from anode towards the center of cathode. Researchers found that perhaps this is another reason that the length of SWCNT is short and only a single SWCNT [61].

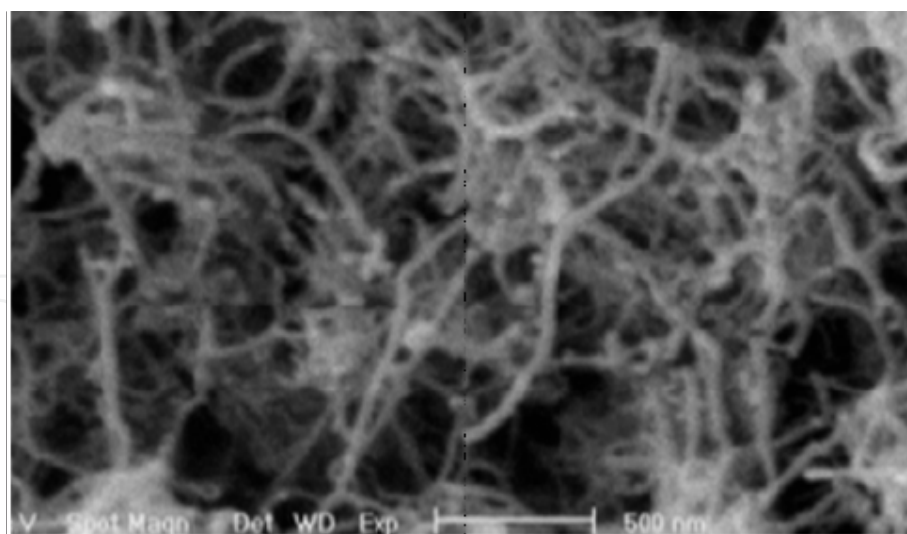

Figure 13. Production of CNTs in NaCl solution [62].

The optimized conditions to synthesize large quantities of SWCNT by applying arc discharge in NaCl solution deserve further investigation. Arc discharge in NaCl solution provides a very simple and cheap method to synthesize CNTs [60].

3.5. Discharge current

Discharge current is another important parameter influencing the products of arc discharge. If the catalyst percentage is 1 mol% Fe, and the discharge current is intentionally reduced to 20 A, the arc became very unstable, and disappear when the voltage is increased to 28 V [63].

3.6. The solution electrical conductivity effect

The effect of electrical conductivity of liquid on CNTs production might be important. A series of experiments carried out and the products were fabricated using arc discharge between two graphite electrodes submerged in different aqueous solutions of NaCl, KCl as well as LiCl. In comparative studies, CNTs were synthesized under different electrical conductivity conditions, and the results were analyzed, compared and discussed. The scanning electron microscopy (SEM), transmission electron microscopy (TEM) and Raman spectroscopy were employed to study the morphology of these carbon nanostructures and reported. LiCl 0.25 N (with 22.7mS as electrical conductivity) media when applied as solution, high-crystalline and a longed multi walled carbon nanotubes, single walled carbon nanotubes and springy carbon nanotubes (SCNTs) were synthesized. This study is one of the first one have demonstrated application of an arc discharge in liquid media with electrical conductivity effects upon CNT preparation and deserves further study (Dehghani and Jahanshahi, (2012); unpublished data).

4. Purification of fabricated CNTs

CNTs usually contain a large amount of impurities such as metal particles, amorphous carbon, and multi shell. There are different steps in purification of CNTs. Purification of CNTs is a process that separates nanotubes from non-nanotube impurities included in the raw products, or from nanotubes with undesired numbers of walls. Purification has been an important synthetic effort since the discovery of carbon nanotubes, and there are many publications discussing different aspects of the purification process. Good review articles on the purification of CNTs are available in the recent literature [64, 65].

The current industrial methods applied oxidation and acid-refluxing techniques that affect the structure of tubes. Purification difficulties are great because of insolubility of CNT and the limitation of liquid chromatography.

CNT purification step (depending on the type of the purification) removes amorphous carbon from CNTs, improves surface area, decomposes functional groups blocking the entrance of the pores or induces additional functional groups.

Most of these techniques are combined with each other to improve the purification and to remove different impurities at the same time. These techniques are as follow:

4.1. Oxidation

Oxidation is a way to remove CNTs impurities. In this way CNTs and impurities are oxidized. The damage to CNTs is less than the damage to the impurities. This technique is more preferable with regard to the impurities that are commonly metal catalysts which act as oxidizing catalysts [66, 67].

Altogether, the efficiency and yield of the procedure are highly depending on a lot of factors, such as metal content, oxidation time, environment, oxidizing agent and temperature [67].

4.2. Acid treatment

Refluxing the sample in acid is effective in reducing the amount of metal particles and amorphous carbon. Different used acids are hydrochloric acid (HCl), nitric acid (HNO₃) and sulphuric acid (H₂SO₄), while HCl is identified to be the ideal refluxing acid. When a treatment in HNO₃ had been used the acid had an effect on the metal catalyst only, and no effects was observed on the CNTs and the other carbon particles. [66-69]. Figure 14 shows the SEM images of CNTs after and before purification stage with HCl [51].

If a treatment in HCl is used, the acid has also a little effect on the CNTs and other carbon particles [69, 70]. A review of literature demonstrates the effects that key variables like acid types and concentration & temperature have on the acid treatment [69, 70].

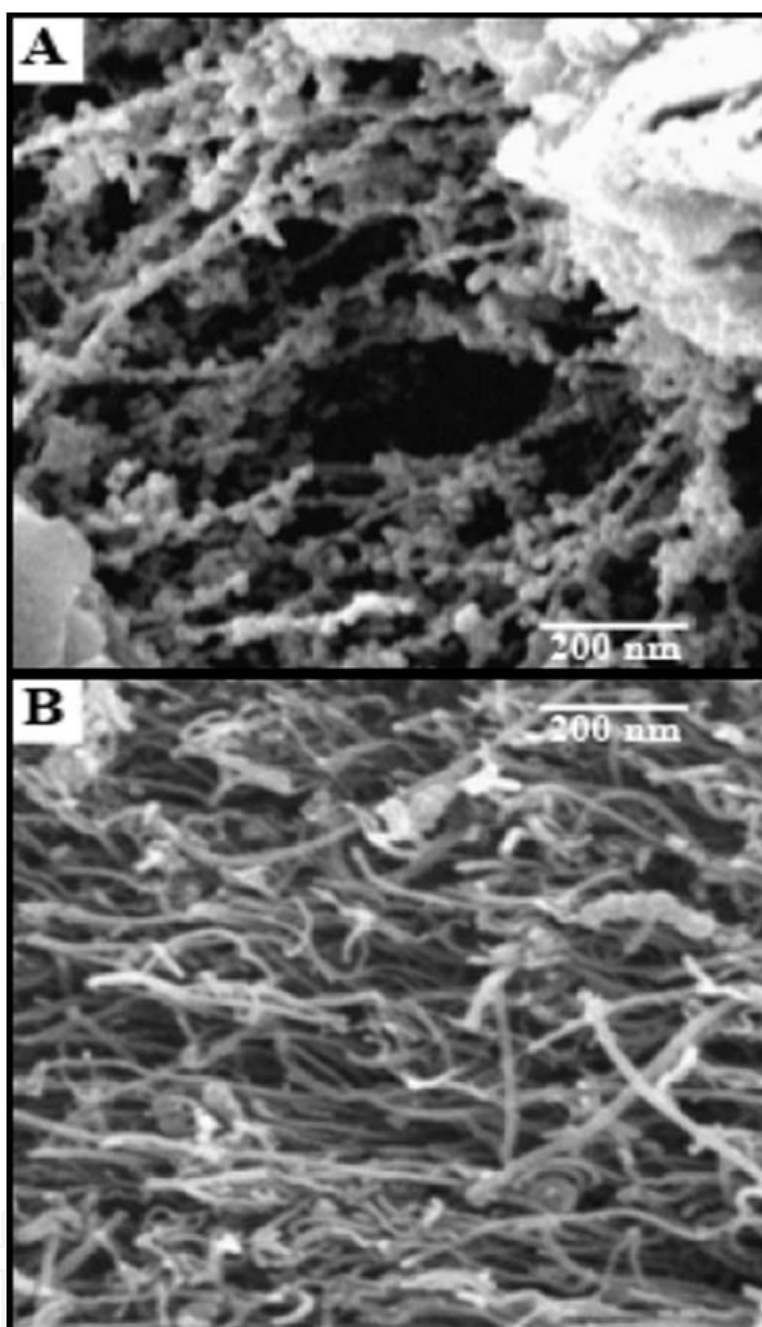

Figure 14. The SEM images of CNTs (A) after (B) before purification stages with HCl [51].

4.3. Annealing and thermal treatment

High temperature has effect on the productions and paralyzes the graphitic carbon and the short fullerenes. When high temperature is used, the metal will be melted and can also be removed [69].

4.4. Ultrasonication

This technique is based on the separation of particles due to ultrasonic vibrations and also agglomerates of different nanoparticles will be more dispersed by this method. The separation of the particles is highly dependable on the surfactant, solvent and reagents which are used [67-70].

When an acid is used, the purity of the CNTs depends on the sonication time. During the tubes vibration to the acid for a short time, only the metal is solvated, but in a more extended period, the CNTs are also chemically cut. [69].

4.5. Micro-filtration

Micro-filtration is based on particle size. Usually CNTs and a small amount of carbon nanoparticles are trapped in a filter. The other nanoparticles (catalyst metal, fullerenes and carbon nanoparticles) are passing through the filter [65, 69, 70, 72].

A special form of filtration is cross flow filtration. Through a bore of fiber, the filtrate is pumped down at head pressure from a reservoir and the major fraction of the fast flowing solution is reverted to the same reservoir in order to be cycled through the fiber again. A fast hydrodynamic flow down the fiber bore sweeps the membrane surface and prevents building up of a filter cake [67].

5. Morphological and structural characterizations

To investigate the morphological and structural characterizations of the CNTs, a reduced number of techniques can be used. It is very important to characterize and determine the quality and properties of the CNTs, since its applications will require certification of properties and functions [74].

However, only few techniques are able to characterize CNTs at the individual level such as scanning tunneling microscopy (STM) and transmission electronic microscopy (TEM). X-ray photoelectron spectroscopy is required to determine the chemical structure of CNTs in spite of the fact that Raman spectroscopy is mostly introduced as global characterization technique.

5.1. Electron microscopy (SEM & TEM)

The morphology, dimensions and orientation of CNTs can be easily revealed by using scanning (SEM) and Transmission Electron Microscopes (TEM) which have high resolution. [70-75] (Figs. 15).

Therefore, the TEM technique is applied as a method for measurement of the outer and inner radius and linear electron absorption coefficient of CNTs [76]. This method is used to study CNTs before and after annealing and notice a significant increase of the electron absorption coefficient. The inter shell spacing of MWNTs was studied by Kiang et al. [77] using high resolution TEM images.

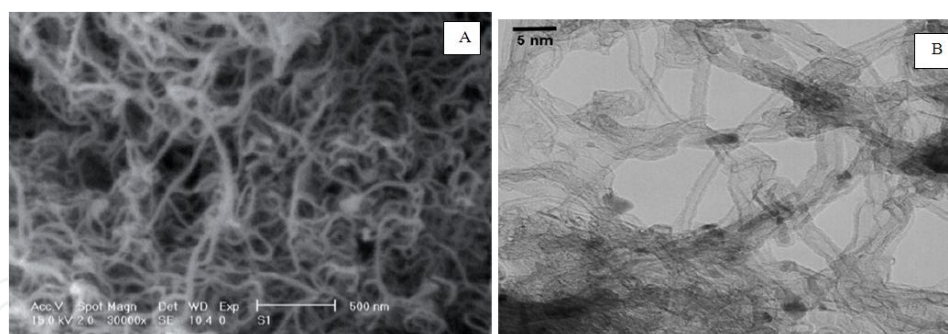

Figure 15. Electron micrographs of CNT (A) SEM of the CNT. (B) TEM of the CNT [57].

5.2. X-ray diffraction (XRD)

This technique is used to obtain some information on the interlayer spacing, the structural strain and the impurities. However, in comparing CNTs with x-ray incident beam, CNTs have multiple orientations. This leads to a statistical characterization of CNTs [78].

5.3. Raman spectroscopy

Raman spectroscopy is one of the most powerful tools for characterization of CNTs. Without sample preparation, a fast and nondestructive analysis is possible. All allotropic forms of carbon are active in Raman spectroscopy [79]. The position, width, and relative intensity of bands are modified according to the carbon forms [80].

A Raman spectrum of a purified sample (after applying the purification procedure) is shown in figure 16. The peaks at 1380 cm^{-1} and 1572 cm^{-1} correspond to disorder (D-band) and graphite (G-band) bands, respectively. The former is an indication of the presence of defective material and the latter one refers to the well-ordered graphite [62].

The most characteristic features are summarized as following:

1. Low-frequency peak $<200\text{ cm}^{-1}$ characteristic of the SWNT, whose frequency is depended on the diameter of the tube mainly (RBM: radical breathing mode).
2. D line mode (disorder line), which is a large structure assign of residual ill-organized graphite.
3. High-frequency bunch that is called G band and is a characteristic of CNTs. This bunch has the ability to be superimposed with the G-line of residual graphite [81].

Raman spectroscopy is considered an extremely powerful tool for characterizing CNT, which gives qualitative and quantitative information on its diameter, electronic structure, purity and crystalline, and distinguishes metallic and semiconducting material as well as chirality.

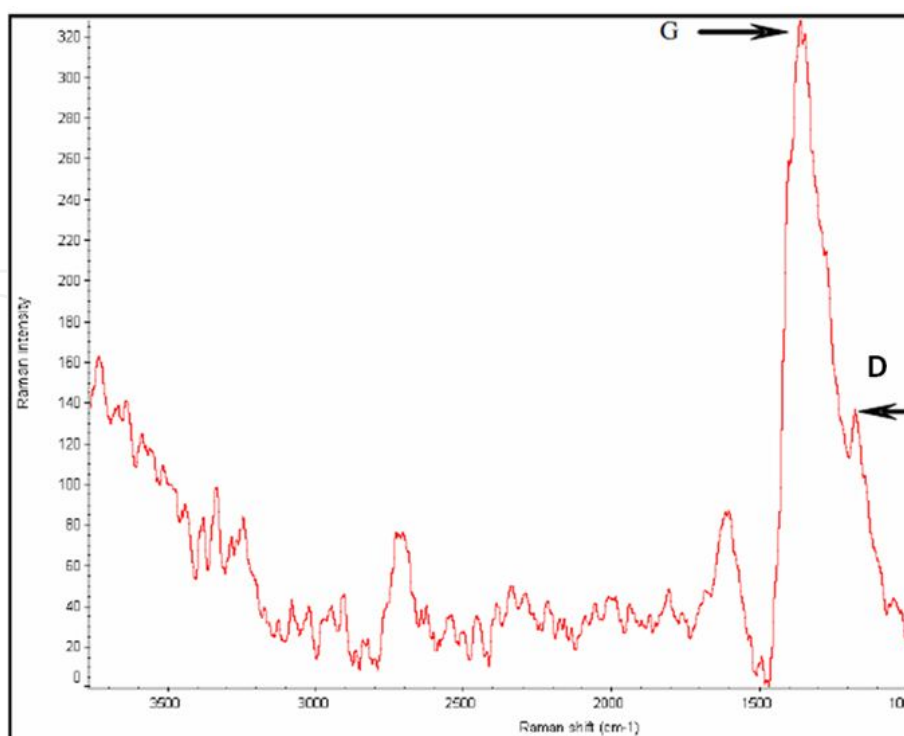

Figure 16. Raman spectrum showing the most characteristic features of CNTs produced by arc discharge method in liquid followed by acid treatment [62].

6. Conclusion

Carbon nanotubes (CNTs), a new structure of carbon element, are composed of graphene sheets rolled into closed concentric cylinders with diameter of the order of nanometers and length of micrometers. CNTs are attracted significant attention because of their unique physical and mechanical properties. These properties have been the engines of the rapid development in scientific studies in numerous applications such as in fuel cell and electrocatalyst, nanobiosensors, gas adsorptions and membrane separation [82-88].

Three methods, laser, arc discharge and chemical vapor deposition are used to synthesize CNTs. The laser method is also known as the laser-furnace method. The quantities CNTs in this method are large but this technique is not economically advantageous, since the process demanded considerable power. The chemical vapor deposition is another method for producing CNTs. It could produce CNTs at temperatures above 700 °C in large quantities, but the walls of the CNTs frequently contain many defects. Traditional arc discharge requires a complicated vacuum and heat exchange system. The yields of the laser and traditional arc discharge methods are very low (mg/h). From the application perspective, researchers are continuously trying to devise improved methods for CNTs fabrication.

Arc discharge in liquid media is a new method of synthesizing CNTs developed recently. All that is required is a dc power supply and an open vessel full of liquid nitrogen, deion-

ized water or aqueous solution. This method is not requiring vacuum equipment, reacted gases, a high temperature furnace and a heat exchange system. Consequently, this method is extremely simple and cheap.

As it has been deeply investigated above, synthesis, purification and characterization of CNTs based on arc discharge in liquid media were described and discussed in this review paper. The observations of CNT growth under electron microscopy and other analytical techniques by different groups suggested that the mechanism are extremely sensitive to each fabrication parameter such as voltage difference between electrodes, current, type and ratio of catalysts, electrical conductivity, concentration, type and temperature of plasma solution and thermal conductivity. All these parameters were reviewed and studied herein. To the best of our knowledge the current review is the first one has discussed all aspects of arc discharge method in liquid media for CNT preparation and this technique deserves further attention.

Acknowledgements

The authors are grateful to Prof. M. Shariaty Niasar (Tehran University, Iran), Prof. J. Raof (The University of Mazandaran, Iran), Dr. H. Molavi and PhD student Mrs R. Jabari Sheresht for their previous collaborations and productive discussion during preparation of this paper.

Author details

Mohsen Jahanshahi* and Asieh Dehghani Kiadehi

*Address all correspondence to: mjahan@nit.ac.ir

Nanotechnology Research Institute and Faculty of Chemical Engineering Babol University of Technology, Babol,, Iran

References

- [1] Iijima, S. (1991). Helical Microtubules of Graphitic Carbon. *Nature*, 354, 56-58.
- [2] Dresselhaus, M. S., Dresselhaus, G., & Eklund, P. C. (1996). Science of fullerenes and carbon nanotubes., Academic Press, New York.
- [3] Dekker, C. (1999). Carbon nanotubes as molecular quantum wires. *Physics Today*, 52, 22-30.
- [4] Tans, S. J., Verschueren, A. R. M., & Dekker, C. (1998). Room-temperature transistor based on a single carbon nanotube. *Nature*, 393, 49-52.

- [5] Javey, A., Kim, H., Brink, M., Wang, Q., Ural, A., Guo, J., Mc Intyre, P., Mc Euen, P., Lundstrom, M., & Dai, H. (2002). *Nature Materials*, 1, 241-246.
- [6] Javey, A., Guo, J., Wang, Q., Lundstrom, M., & Dai, H. J. (2003). Ballistic Carbon Nanotube Transistors. *Nature*, 424, 654-657.
- [7] Rosenblatt, S., Yaish, Y., Park, J., Gore, J., Sazonova, V., & Mc Euen, P. L. (2002). High Performance Electrolyte Gated Carbon Nanotube Transistors. *Nano Letters*, 2, 869-872.
- [8] Lu, C., Fu, Q., Huang, S., & Liu, J. (2004). *Nano Letters*, 4-623.
- [9] Huang, S. M., Woodson, M., Smalley, R., & Liu, J. (2004). Growth Mechanism of Oriented Long Single Walled Carbon Nanotubes Using "Fast-Heating" Chemical Vapor Deposition Process. *Nano Letters*, 4, 1025-1028.
- [10] Tan, S. J., Devoret, M. H., Dai, H. J., Thess, A., Smalley, R. E., Geerligs, L. J., & Dekker, C. (1997). *Nature*, 386-474.
- [11] Bockrath, M., Cobden, D. H., & Mc Euen, P. L. (2000). Individual Single-Wall Carbon Nanotubes As Quantum Wires. *Science*, 290, 1552-1555.
- [12] Dai, H. J., Hafner, J. H., Rinzler, A. G., Colbert, D. T., & Smalley, R. E. (1996). Nanotubes As Nanoprobes in Scanning Probe Microscopy. *Nature*, 384, 147-150.
- [13] Wong, S. S., Harper, J. D., Lansbury, P. T., & Lieber, C. M. (1998). *Am J. Chem. Soc.*, 120, 603.
- [14] Rinzler, A., & Hafner, J. (1995). Unraveling Nanotubes- Field-Emission from an Atomic Wire. *Science*, 269, 1550-1553.
- [15] Collins, P. G., Bradley, K., Ishigami, M., & Zettl, A. (2000). Extreme oxygen sensitivity of electronic properties of carbon nanotubes. *Science*, 287, 1801-1804.
- [16] Kong, J., Franklin, N. R., Zhou, C., Peng, S., Cho, J. J., & Dai, H. (2000). Nanotube molecular wires as chemical sensors. *Science*, 287, 622-625.
- [17] Chen, R. J., Bangsaruntip, S., Drouvalakis, K. A., Kam, N. W. S., Shim, M., Li, Y. M., Kim, W., Utz, P. J. H., Dai, J., & Natl, P. (2003). Nanotube molecular wires as chemical sensors. *Acad. Sci. USA*, 100, 4984-4989.
- [18] Star, A., Gabriel, J. C. P., Bradley, K., & Grüner, G. (2003). Electronic detection of specific protein binding using nanotube FET devices. *Nano Letters*, 3, 459-463.
- [19] Kuchta, B., Firlej, L., Pfeifer, P., & Wexler, C. (2010). Numerical Estimation of Hydrogen Storage Limits in Carbon Based Nanospaces. *Carbon*, 48, 223-231.
- [20] Scott, C., Arepalli, S., Nikolaev, P., & Smalley, R. E. (2001). *Applied Physics A: Materials Science & Processing*, 72, 573-580.
- [21] Bethune, D., Kiang, C., De Vries, M., Gorman, G., Savoy, R., & Beyer, R. (1993). *Nature*, 363, 605-607.

- [22] Journet, C., Maser, W. K., Bernier, P., Loiseau, A., Chapelle, M., Lefrant, S., Deniard, P., Lee, R., & Fischer, J. E. (1997). Large scale production of single wall carbon nanotubes by the electric arc technique. *Nature*, 388, 756-758.
- [23] Cassell, A. M., Raymakers, J. A., Kong, J., & Dai, H. (1999). Solvation of fluorinated single-wall carbon nanotubes in alcohol solvents. *Journal of Physical Chemistry B*, 103, 6484-6492.
- [24] Liu, J., Fan, S., & Dai, H. (2004). *MRS Bulletin*, 4, 224-250.
- [25] Jabari, Seresht. R., & Jahanshahi, M. (2010). *Fullerenes Nanotubes Carbon Nanostruct*, 2, 1-12.
- [26] Biró, L., Horváth, Z., Szalmás, L., Kertész, K., Wéber, F., Juhász, G., Radnóczy, G., & Gyulai, J. (2003). Continuous carbon nanotube production in underwater ac electric arc. *Chemical physics letters*, 372, 399-402.
- [27] Feng, Y., & Zhou, G. (2003). Removal of some impurities from carbon nanotubes. *Chemical physics letters*, 375, 645-648.
- [28] Guo, T., Diener, M., & Chai, Y. (1992). Uranium Stabilization of C28- a Tetravalent Fullerene. *Science*, 257, 1661-1664.
- [29] Thess, A., & Lee, R. (1996). Crystalline Ropes of Metallic Carbon Nanotubes. *Science*, 273, 483-487.
- [30] Bandow, S., & Rao, A. (1997). Purification of single-wall carbon nanotubes by micro-filtration. *Journal of Physical Chemistry B*, 101, 8839-8842.
- [31] Chiang, I., & Brinson, B. (2001). *Journal of Physical Chemistry B*, 105, 8297-8301.
- [32] Ishii, H., & Kataura, H. (2003). Direct observation of Tomonaga-Luttinger-liquid state in carbon nanotubes at low temperatures. *Nature*, 426, 540-544.
- [33] Puretzy, A., & Geohegan, D. (2000). *Applied Physics A: Materials Science & Processing*, 70, 153-160.
- [34] Sen, R., & Ohtsuka, Y. (2000). Time period for the growth of single-wall carbon nanotubes in the. *Chemical physics letters*, 332, 467-473.
- [35] Kokai, F., & Takahashi, K. (2000). *Journal of Physical Chemistry B*, 104, 6777-6784.
- [36] Li, Y., & Mann, D. (2004). *Nano Letters*, 4, 317-321.
- [37] Walker, P., & Rakszawski, J. (1959). *Journal of Phys. Chem*, 63, 133-140.
- [38] Dresselhaus, M., & Dresselhaus, G. (1988). Physical Properties of Carbon Nanotubes : Synthesis, Structure, Properties and Applications. Springer-Verlag, Berlin.
- [39] Endo, M. (1988). Grow Carbon Fibers in the Vapor Phase. *Chemtech*, 18, 568-576.
- [40] Baker, R. T. K., & Harris, P. S. (1978). Marcel Dekker, New York.

- [41] Tibbetts, G. G. (1984). Why are carbon filaments tubular? *Journal of crystal growth*, 66, 632-638.
- [42] Seresht, R. J., Jahanshahi, M., & Yazdani, M. (2009). Parametric study on the synthesis of single wall carbon nanotube by gas arc-discharge method with multiple linear regressions and artificial neural network. *International Journal of Nanoscience*, 8, 243-249.
- [43] Saito, Y., & Inagaki, M. (1992). Yield of fullerenes generated by contact arc method under He and Ar-dependence on carbon nanotube. *Chemical physics letters*, 200, 643-648.
- [44] Ebbesen, T., & Ajayan, P. (1992). *Nature*, 358, 220-222.
- [45] Belin, T., & Epron, F. (2005). Characterization methods of carbon nanotubes: a review. *Materials Science and Engineering B*, 119, 105-118.
- [46] Jahanshahi, M., Raoof, J., Hajizadeh, S., & Jabari, Seresht. R. (2007). *Nanotechnol. Appl.*, 929, 71-77.
- [47] Bera, D., & Johnston, G. (2006). A parametric study on the nanotube structure through arc-discharge in water. *Nanotechnology*, 17, 1722-1730.
- [48] Ishigami, M., & Cumings, J. (2000). A simple method for the continuous production of carbon nanotubes. *Chemical physics letters*, 319, 457-459.
- [49] Jung, S. H., & Kim, M. R. (2003). *Applied Physics A: Materials Science & Processing* . 76, 285-286.
- [50] Lange, H., Sioda, M., Huczko, A., Zhu, Y. Q., Kroto, H. W., & Walton, D. R. M. (2003). Nanocarbon production by are discharge in water. *Carbon*, 41, 1617-1623.
- [51] Jahanshahi, M., & Seresht, R. J. (2009). Catalysts effects on the production of carbon nanotubes by an automatic arc discharge set up in solution. *physica status solidi (c)*, 6, 2174-2178.
- [52] Xing, G., & Jia, S. (2007). Influence of transverse magnetic field on the formation of carbon nanotube. *Carbon*, 45, 2584-2588.
- [53] Xu, B., Guo, Ju., Wang, X., Liu, X., & Ichinose, H. (2006). Synthesis of carbon nanocapsules containing Fe, Ni or Co by arc discharge in aqueous solution. *Carbon*, 44-2631.
- [54] Seraphin, S., & Zhou, D. (1994). *Applied Physics Letters*, 64, 2087-2089.
- [55] Saito, Y., & Tani, Y. (1998). High yield of single-wall carbon nanotubes by arc discharge using Rh-Pt mixed catalysts. *Chemical physics letters*, 294, 593-598.
- [56] Hsin, Y. L., Hwang, K. C., Chen, R. R., & Kai, J. J. (2001). Production and in-situ Metal Filling of Carbon Nanotubes in Water. *J. Advanced Materials*, 13, 830-833.
- [57] Dehghani, Kiadehi. A., Jahanshahi, M., Mozdianfard, M. R., Vakili-Nezhaad, G. H. R., & Jabari, Seresht. R. (2011). Influence of the solution temperature on carbon nano-

- tube formation by arc discharge method. *Journal of Experimental Nanoscience*, 4, 432-440.
- [58] Jahanshahi, M., Raof, J., & Seresht, R. J. (2009). Voltage effects on production of nanocarbons by a unique arc-discharge set-up in solution. *Journal of Experimental Nanoscience*, 4, 331-339.
- [59] Lide, D. R. (2003). *CRC handbook of chemistry and physics; CRC Pr I Llc*.
- [60] Wang, Sh., Chang, M., Lan, K. M., Wu, Ch., Cheng, J., & Chang, H. (2005). *Carbon*, 43, 1778-1814.
- [61] Schur, D. V., Dubovoy, A. G., Zaginaichenko, S., Yu, Adejev. V. M., Kotko, A. V., Bogolepov, V. A., Savenko, A. F., & Zolotarenko, A. D. (2007). *Carbon*, 45, 1322-1329.
- [62] Jahanshahi, M., Raof, J., Hajizadeh, S., & Seresht, R. J. (2009). Synthesis and subsequent purification of carbon nanotubes by arc discharge in NaCl solution. *Phys. Status Solidi A*, 1, 101-105.
- [63] Wang, S. D., Chang, M. H., Cheng, J. J., Chang, H. K., & Lan, K. M. D. (2005). *Carbon*, 43, 1317-1339.
- [64] Park, T. J., Banerjee, S., Hemraj-Benny, T., & Wong, S. S. (2006). *Mater J. Chem.*, 16, 141-154.
- [65] Haddon, R. C., Sippel, J., Rinzler, A. G., & Papadimitrakopoulos, F. (2004). Purification and separation of carbon nanotubes. *MRS Bull.*, 29, 252-259.
- [66] Hajime, G., Terumi, F., Yoshiya, F., & Toshiyuki, O. (2002). Method of purifying single wall carbon nanotubes from metal catalyst impurities. Honda Giken Kogyo Kaishiki Kaisha, Japan.
- [67] Borowiak-Palen, E., & Pichler, T. (2002). *Chemical physics letters*, 363, 567-572.
- [68] Farkas, E., Anderson, M. E., Chen, Z. H., & Rinzler, A. G. (2002). Length sorting cut single wall carbon nanotubes by high performance liquid chromatography. *Chem. Phys. Lett.*, 363, 111-116.
- [69] Kajiura, H., Tsutsui, S., Huang, H. J., & Murakami, Y. (2002). High-quality single-walled purification from arc-produced soot. *Chem Phys Lett.*, 364, 586-92.
- [70] Chiang, I., & Brinson, B. (2001). *Journal of Physical Chemistry B*, 105, 8297-8301.
- [71] Bandow, S., & Rao, A. (1997). *Journal of Physical Chemistry B*, 101, 8839-8842.
- [72] Moon, J. M., & An, K. H. (2001). High-yield purification process of singlewalled carbon nanotubes. *Journal of Physical Chemistry B*, 105, 5677-5681.
- [73] Jahanshahi, M., Tobi, F., & Kiani, F. (2005). Carbon-Nanotube Based Nanobiosensors: Paper presented at Electrochemical Pretreatment. The 10th Iranian Chemical Engineering Conference,, Zahedan, Iran.

- [74] Mawhinney, D. B., Naumenko, V., Kuznetsova, A., Yates, J. T., Liu, J., & Smalley, R. E. (2000). Surface defect site density on single walled carbon nanotubes by titration. *Chem. Phys. Lett.*, 324, 213-216.
- [75] Li, W., Wen, J., & Tu, Y. (2001). *Ren Z. Appl. Phys. A*, 73, 259-264.
- [76] Gommès, C., & Blacher, S. (2003). *Carbon*, 41, 2561-2572.
- [77] Kiang, C. H., & Endo, M. (1998). Size effect in carbon nanotubes. *Physical review letters*, 81, 1869-1872.
- [78] Zhu, W., Miser, D., Chan, W., & Hajaligol, M. (2003). *Mater. Chem. Phys.*, 82, 638-647.
- [79] Arepalli, S., & Nikolaev, P. (2004). Protocol for the characterization of SWCNT material quality. *Carbon*, 42, 1783-1791.
- [80] Ferrari, A., & Robertson, J. (2000). *Physical Review B*, 61, 14095.
- [81] Hiura, H., Ebbesen, T. W., Tanigaki, K., & Takahashi, H. (1993). Single-walled carbon nanotubes produced by electric arc. *Chem. Phys. Lett.*, 202, 509.
- [82] Raouf, J. B., Jahanshahi, M., & Momeni, Ahangar. S. (2010). Nickel Particles Dispersed into Poly (o-anisidine) and Poly (oanisidine)/Multi-walled Carbon Nanotube Modified Glassy Carbon Electrodes for Electrocatalytic Oxidation of Methanol. *Int. J. Electrochem. Sci.*, 5, 517-530.
- [83] Toubi, F., Jahanshahi, M., Rostami, A. A., & Hajizadeh, S. (2009). Voltametric tests on different carbon nanotubes as nanobiosensor devices. *D. Biochem Process Biotech. Mol. Biol.*, 2, 71-74.
- [84] Khalili, S., Ghoreyshi, A. A., & Jahanshahi, M. (2012). Equilibrium, kinetic and thermodynamic studies of hydrogen adsorption on multi-walled carbon nanotubes. *Iranica Journal of Energy & Environment*, 1, 69-75.
- [85] Delavar, M., Ghoreyshi, A. A., Jahanshahi, M., Khalili, S., & Nabian, N. (2012). The effect of chemical treatment on adsorption of natural gas by multi-walled carbon nanotubes: sorption equilibria and thermodynamic studies. *Chemical Industry & Chemical Engineering Quarterly Inpress*.
- [86] Delavar, M., Ghoreyshi, A. A., Jahanshahi, M., & Nabian, N. (2012). *Journal of Experimental Nanoscience Inpress*.
- [87] Delavar, M., Ghoreyshi, A. A., Jahanshahi, M., Khalili, S., & Nabian, N. (2012). Equilibria and kinetics of natural gas adsorption on multi-walled carbon nanotube material. *Green Chemistry*, 2, 4490-4497.
- [88] Rahimpour, A, Jahanshahi, M, Khalili, S, Mollahosseini, A, Zirepour, A, & Rajaeian, B. (2012). Novel functionalized carbon nanotubes for improving the surface properties and performance of polyethersulfone (PES) membrane. *J. Desalination.*, 286, 99-107.