

# We are IntechOpen, the world's leading publisher of Open Access books Built by scientists, for scientists

## 4,800

Open access books available

## 122,000

International authors and editors

## 135M

Downloads

Our authors are among the

## 154

Countries delivered to

## TOP 1%

most cited scientists

## 12.2%

Contributors from top 500 universities

**WEB OF SCIENCE™**Selection of our books indexed in the Book Citation Index  
in Web of Science™ Core Collection (BKCI)

Interested in publishing with us?  
Contact [book.department@intechopen.com](mailto:book.department@intechopen.com)

Numbers displayed above are based on latest data collected.

For more information visit [www.intechopen.com](http://www.intechopen.com)

# Building Information Systems – Extended Building-Related Information Systems Based on Geospatial Standards

Jörg Blankenbach and Catia Real Ehrlich  
*Technische Universität Darmstadt,  
Germany*

## 1. Introduction

In the context of facility management, specific building information systems or so called Computer Aided Facility Management (CAFM) systems are often utilised. Similar to geo information systems, these systems use geometric and graphical data (e.g. CAD floor plans) for space management inside buildings. By the use of current trends in geo information science (e.g. 3D interior room models) these systems could be extended considerably. Moving to real-time data exchange and interoperability across several systems; geo standards and geo web services can be used for the description and provision of building objects with all their information. Thus, new web or mobile applications based on building information systems will become possible where geo information plays a crucial role. The applications, which could benefit from such extended building information systems, reaches from services for improved facility management (e.g. inspection and maintenance) to mobile navigation for pedestrians and emergency staff (e.g. fire fighters).

This chapter introduces CAFM-systems. Modern geo information standards like CityGML and geo web services are described (Section 3), which could be used to extend these systems. Workflow and software architecture for utilising these standards for building information systems will be outlined (Section 4). In conclusion, application examples which could benefit from these new building information systems are demonstrated (Section 5).

## 2. Motivation and subjective

In general, Geo Information Systems (GIS) are tools for the capture, storage, management, visualisation, and presentation of spatial related data. In addition, this spatial data can be queried, analysed, evaluated, or simulated in real time. Usually geo information systems are used for outdoor issues (i.e. urban planning), but buildings, their interior components, and assemblies are also spatially referenced and can be implemented with a GIS. For the management and provision of (spatial and non-spatial) building data, Building Information Systems (BIS) can be applied. With Computer Aided Facility Management (CAFM) systems, a type of GIS for buildings already exists supporting in particular the facility management. Specifically the space management in CAFM systems i.e. for cleaning, occupancy, or lease issues are done with geometric data of the building quite similar to GIS. Most CAFM

systems, however, are using 2D data such as floor plans or 2D CAD drawings. The user interface of these systems are normally desktop or browser (web) clients (Figure 16).

With the third dimension an enhanced description of the building is possible. Details of a building such as installations and equipment can be described more realistically and viewed in each possible perspective. The observer stands in the centre of the 3D building and can move on his own axis or change the line of sight in this scene. Materials, textures, lights, and other effects make the 3D interior building model more realistic. The observer in virtual reality can examine and analyse the building without being on-site. When on-site the user, equipped with a mobile device, can find his/her way through the building without cumbersome plans in his/her hands and can demand and display building attributes (e.g. building services). A plethora of questions and problems may be solved and are suitable for many business applications.

The deployment of a geo information system on the basis of three-dimensional interior building models requires the correct modelling of geometry, semantics, and topology as well as the provision of this data via standardised web based interfaces.

### 3. Basic technologies

Standardisation plays an important role in the multifunctional use and profitability of a building information system. Web standards ensure that information can be accessed by all users and applications (interoperability).

The next sections describe the important basic technologies which will support the developed building information system.

#### 3.1 CityGML

CityGML is an interoperable data model of the Open Geospatial Consortium (OGC) for virtual 3D models of a city and can be used to describe, exchange geometric and topological, as well as semantic properties of buildings. This standard is based on XML (Extensible Markup Language), an expandable, text based, and standardised format for the representation of any information (e.g. documents, data, configuration, or transaction).

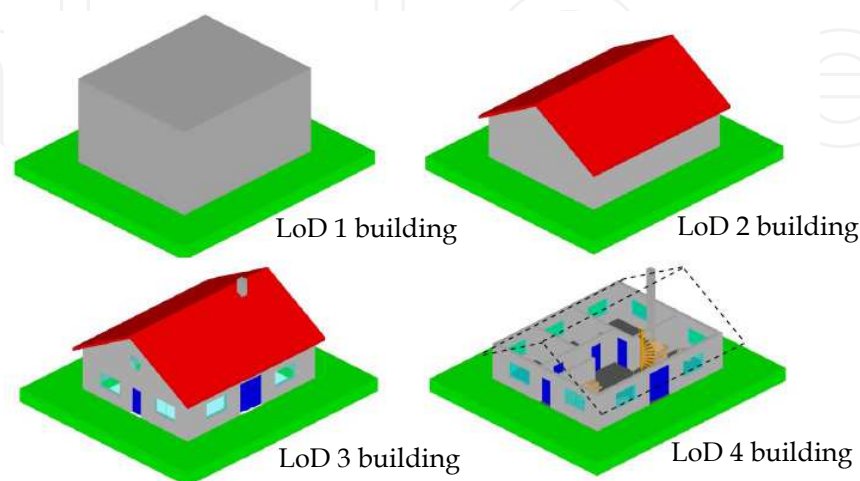

Fig. 1. Building model in LoD 1 to LoD 4 (Gröger et al., 2008)

CityGML differentiates between four Levels of Detail (LoD 0-4). For example, a building can be described geometrically as block model in level 1 or as an interior room model in level 4 (see Fig. 1). With increasing level, more details about the building will be depicted and the building model gains clarity and expressiveness. The following table describes the correspondence of the different building objects to LoDs. (Bleifuss, 2009; Gröger et al., 2008)

Building features	LoD 1	LoD 2	LoD 3	LoD 4
Building shell	x	x	x	x
Outer boundary surfaces (outer wall, roof, ground)		x	x	x
Outer building installations		x	x	x
Openings (Door, Window)			x	x
Rooms				x
Interior boundary surfaces (ceiling, floor, interior wall, closure surface)				x
Interior building installations				x
Building furniture				x

Table 1. Building features with their Levels of Detail (in according to Gröger et al., 2008)

CityGML includes a geometric, topological, and a semantic model. All models can be linked together and used for the execution of thematic queries, analyses, and simulations. The semantic model defines real objects in the form of classes, which represent the meaning and classification of objects. These objects (e.g. buildings, outer walls, windows, or rooms) are referred to as *features*. The geometric model allows the definition of geometric properties of three-dimensional spatial objects. For this, the position and form of the CityGML-feature is described uniformly as GML-geometry. GML (Geography Markup Language) is a XML-based, international standard for the exchange of geo data. It allows the modelling of 0-3-dimensional objects. For the relations between features, CityGML offers a topological model. The relationship is implemented through references. Multiple Features can refer to the same feature or geometry object. (Gröger et al., 2008)

Figure 2 illustrates a part of CityGML document. Every building component can be modelled with CityGML building features. In addition to the description of the building with attributes (e.g. class, function, usage, year of construction, year of demolition, roof type, measured height, ...), a wall surface for the presentation of a building in LoD 4 is defined. The wall surface is combined by multiple GML surfaces (*gml:MultiSurface*), which in turn is described with GML polygons (*gml:Polygon*). Subsequently rooms, outer building installations, room installations, and building furniture can be modelled.

The CityGML document can be viewed with dedicated software. For example, LandXplorer CityGML Viewer from Autodesk (available from <http://www.citygml.org>) is a visualisation program which allows the simultaneous display of geometric and semantic properties of buildings.

```

<?xml version="1.0" encoding="UTF-8"?>
<CityModel
...
xmlns:citygml="http://www.citygml.org/citygml/1/0/0"
xmlns:bldg="http://www.opengis.net/citygml/building/1.0"
xmlns:gml="http://www.opengis.net/gml"
xmlns="http://www.opengis.net/citygml/1.0">
  <cityObjectMember>
    <bldg:Building gml:id="BUILDING_1">
      <bldg:class> schools, education, research </bldg:class>
      <bldg:function> kindergarten or nursery </bldg:function>
      <bldg:usage> kindergarten or nursery </bldg:usage>
      <bldg:roofType> combination of roof forms </bldg:roofType>
      <bldg:storeysAboveGround>3</bldg:storeysAboveGround>
      <bldg:storeysBelowGround>1</bldg:storeysBelowGround>
      ...
      <bldg:boundedBy>
        <bldg:WallSurface gml:id="SURFACE_1">
          <bldg:lod4MultiSurface>
            <gml:MultiSurface>
              <gml:surfaceMember>
                <gml:Polygon>
                  <gml:exterior>
                    <gml:LinearRing>
                      <gml:posList count="5" srsDimension="3">
                        7.196 2.719 -4.294
                        6.623 2.713 -4.294
                        6.556 10.749 -4.294
                        7.123 10.752 -4.294
                        7.196 2.719 -4.294
                      </gml:posList>
                    </gml:LinearRing>
                    ...
                  </gml:MultiSurface>
                <gml:MultiSurface>
                  ...
                </gml:MultiSurface>
              </bldg:lod4MultiSurface>
            <bldg:opening>
              ...
            </bldg:opening>
          </bldg:WallSurface>
        </bldg:boundedBy>
        ... outerBuildingInstallation, roomInstallation, interiorFurniture
      </bldg:Building>
    </cityObjectMember>
  </CityModel>

```

Fig. 2. Part of a CityGML document

### 3.2 Geo Web Services

Web services represent a modern model for Internet based applications following the paradigm of Service Oriented Architectures (SOA). This architecture bases on components (i.e. services) that can be plugged together to build larger more comprehensive services. Each service is self-describing and provides standardised interfaces. Geo Web Services are specialised web services following the standards of the OGC as framework for online geospatial services such as mapping, geo data providing, or geo processing services. These services, also called OGC Web Services (OWS), allow distributed geo processing systems to communicate with each other across the Web using familiar technologies such as XML and HTTP. The following subchapters detail several OWS which support three-dimensional geo data.

### 3.2.1 Web Feature Service

The Web Feature Service (WFS) is one of the basic OGC Web Service for the access and manipulation of geo information at any time and place. For the exchange of geo data, GML is used, which allow the storing, editing, and transformation of spatial information in vector format.

The communication is carried out by a software client (e.g. Web browser). In this process, the WFS receives the client-request and sends back a response to the client (see Fig. 3). The service will be available via a fixed address (Uniform Resource Locator, URL). (Vretanos, 2005)

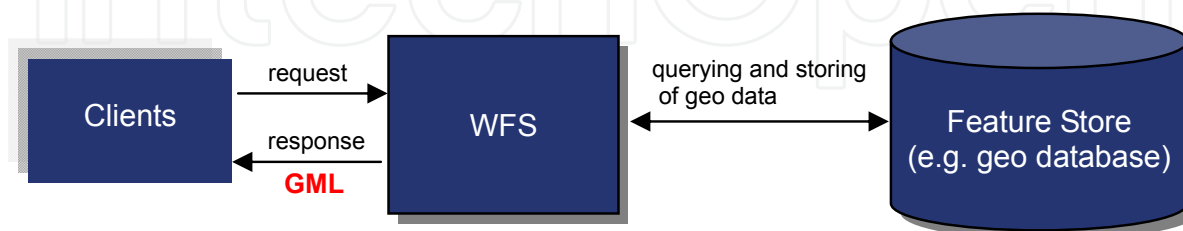

Fig. 3. Interaction of a WFS

According to the OGC-specification, the WFS provided up to six request operations (Vretanos, 2005):

- *GetCapabilities*
- *GetFeature*
- *DescribeFeatureType*
- *Transaction*
- *GetGMLObject*
- *LockFeature*

For the query of all or individual feature instances, the *GetFeature* operation can be used.

### 3.2.2 Web 3D Service

At the moment, OGC develops several services for the visualisation of three-dimensional geo data (<http://www.opengeospatial.org/standards/dp>). Examples include the Web Terrain Service (WTS), the Web View Service (WVS) and the Web 3D Service (W3DS). The WTS and WVS provide the internet user a rendered picture (JPEG, PNG, etc.) of 3D geo data. The selection, displaying, and rendering of geo features is executed by the server (Thick Server), refer Figure 4. The advantages of thick-server-models are that clients do not need specially hardware and software updates. Technical changes are installed on the server. Disadvantages are severely limited interaction of the client site and potential server overload. For every interaction of the user new rendered pictures must be sent to the client, meaning the geo data must be again selected, viewed, and rendered by the server. If too many clients queries at the same time, it may lead to delays and the client is waiting for an answer. In the worst case scenario it could lead to a breakdown of the server.

The Web 3D Service (W3DS) allows also the visualisation and navigation of 3D geo data on the web. In contrast to the other services, the W3DS transfers a 3D graphic format to the

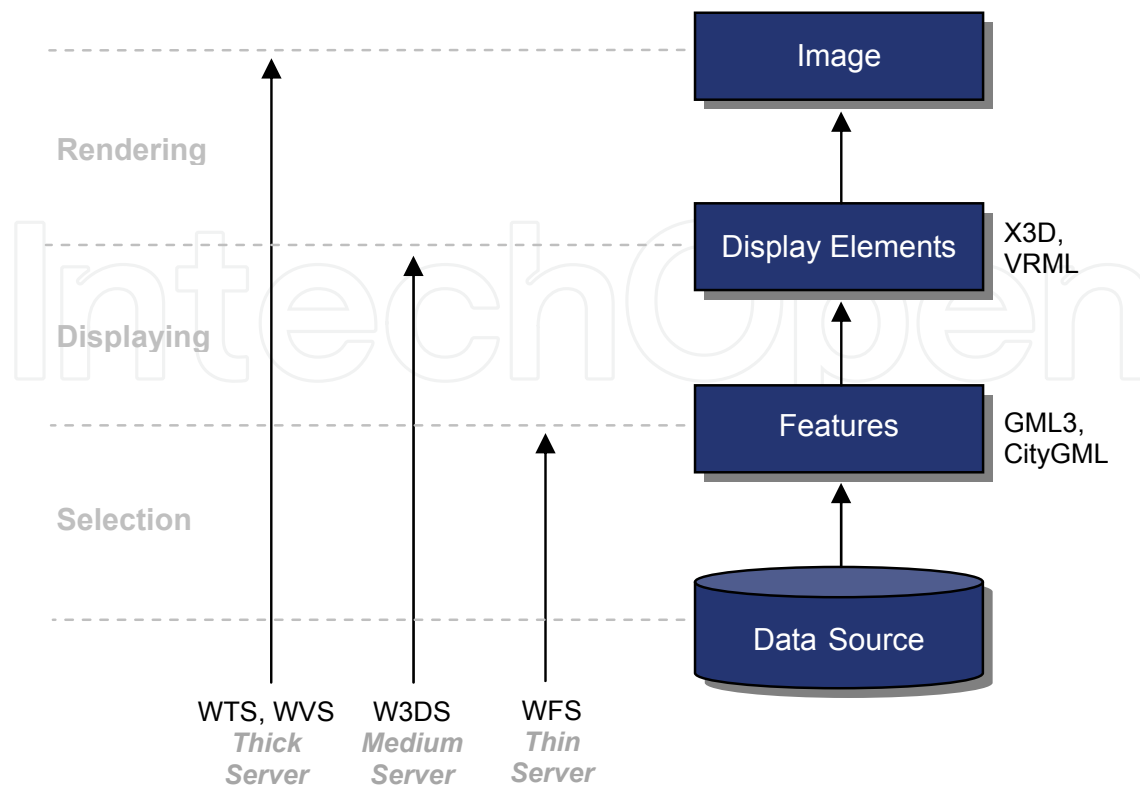

Fig. 4. Several 3D web services (in according to Schilling et al., 2010)

client, which contains a 3D scene. The 3D scene can be viewed interactively in the web browser with 3D plug-ins or in a visualisation software (Medium Server). Through the use of standards and plug-ins, a simple operation of the visualisation of 3D geo data in the web is possible. (Schilling et al., 2010)

For the visualisation of geo data in the web the W3DS supports several 3D graphic formats, for example X3D (Extensible 3D) or VRML (Virtual Reality Modeling Language). VRML is a text based format and is used as description and visualisation of 3D scenes in the web. X3D is a XML based standard for three-dimensional graphics in the web. In view of high complexity, inability to expand, and the large data volumes of the VRML standard this standard will be replaced by X3D. With X3D it is possible to create and visualise complex geometry objects. The structure of X3D is divided into header and scene (see Fig. 5). The header include the metadata (title, creator, description, created, version, ...) for the specification of the document. The scene contains the description of the 3D world with lights, background, navigation, viewpoint, and shapes. The element shape defines the geometry and appearance of the geometry object. In addition to the basic geometric forms (box, cone, cylinder, and sphere) it allows to describe objects with coordinates (IndexFaceSet), extrusion of 2D geometries (Extrusion) and elevation grid (ElevationGrid). (Pomaska, 2007)

A W3DS enables the visualisation of 3D scenes in the X3D format. The service provides five operations, which could be accessed by the user. The *GetScene* operation provides a scene in X3D or VRML format and can be viewed in a internet browser.

- *GetCapabilities*
- *GetScene*
- *GetFeatureInfo*
- *GetTile*
- *GetLayerInfo*

The W3DS is presently an OGC discussion paper but it will, in all probability, become an OGC standard. (Schilling et al., 2010)

```
<?xml version="1.0" encoding="UTF-8"?>
<X3D
  xmlns:xsd="http://www.w3.org/2001/XMLSchema-instance"
  xsd:noNamespaceSchemaLocation="http://www.web3d.org/specifications/x3d-3.0.xsd"
  profile="Interchange" version="3.0">
  <head>
    <meta name="title" content="building"/>
    <meta name="description" content="X3D-Model of a Building"/>
    <meta name="created" content="08.12.2010"/>
    <meta name="modified" content="08.12.2010"/>
    <meta name="generator" content="transformation.CityGMLToX3D"/>
  </head>
  <Scene>
    <Background groundColor=".1 .4 .1" skyColor=".8 .8 1"/>
    <Shape>
      <IndexedFaceSet convex="false" solid="false" coordIndex=" 5 6 7 -1 4 5 7
-1 4 7 8 -1 4 8 9 -1 3 4 9 -1 3 9 0 -1 3 0 1 -1 3 1 2 -1">
        <Coordinate point="2.0 6.613 -3.221, 2.558 6.613 -3.224, 4.794 9.419 -3.236,
4.794 9.489 -3.236, 8.023 9.489 -3.254, 8.023 9.151 -3.254, 9.985 6.613 -3.264,
10.543 6.613 -3.264, 7.666 10.009 -3.252, 5.019 10.046 -3.238, "/>
      </IndexedFaceSet>
      <Appearance>
        <Material diffuseColor="0.5 0.1 0.1" transparency="0.0"/>
      </Appearance>
    </Shape>
    <Shape>
      ...
    </Shape>
    ...
  </Scene>
</X3D>
```

Fig. 5. Part of a X3D document

## 4. Workflow and architecture

The development of a building geo information system by the use of CityGML and Geo Web Services require some important steps; capture, storage, management, provision, visualisation, and analysis of building-related geo data. A brief overview of these consecutive steps is described below.

### 4.1 Capture

For measuring as the basis for the building data capturing various techniques like hand measurements, laser scanning, photogrammetry, or tachymetry can be employed.



### Hand measurements

For the acquisition of simple geometries, measuring tapes, folding rules, and laser distance meters can be used. If the room is not rectilinear and complex, the method reaches its limits. This technique is mostly consulted as extended method for the building survey.

### Tachymetry

With electro-optical distance measuring, a tachymeter determines contactless the position of points (polar point determination). In addition to the measuring of horizontal and vertical angles the total station is able to measure distances very precisely.

### Photogrammetry

An additional possible process is photogrammetry. The 3D object is recorded by a camera. Before 3D measurements can be made on the recording photos all pictures have to be analysed (determination of camera parameters, etc.). Contact with the object is not necessary.

### Laser scanning

With a laser scanning the room can be scanned automatically in a raster. In short periods of time, a great number of points with  $x,y,z$ -coordinates (also called 3D point cloud) is available (polar point determination). From this 3D point cloud a CAD model can be obtained.

The choice of a suitable capturing method depends on the recorded object (interior building structure, lighting, size, usage, etc.), on the completeness, accuracy, speed, and efficiency required. The table below compares various methods.

	Hand measurement	Tachymetry	Photo-grammetry	Laser scanning
Expenditure of time in capturing	-	+	++	++
Accuracy of individual measurement	+	++	++	++
Expenditure of time in object modelling	-	+	-	--
Topology	+	+	-	-
Semantic	-	++	+	--

Table 2. Capturing methods by comparison (+: good, -: bad)

Tachymetry utilises a total station enabling the precise determination of individual points of space on the basis of electro-optical distance measuring. It can be equipped with a laser range finder to measure reflectorless. Horizontal directions, vertical angles, and slope distances are registered simultaneously and stored digitally.

If the total station is connected to a computer (e.g. notebook, handheld), the evaluation or construction of the data can be done on-site (see Fig. 6). In this process the measurement data is sent from the instrument to the computer. At the computer the data is processed and

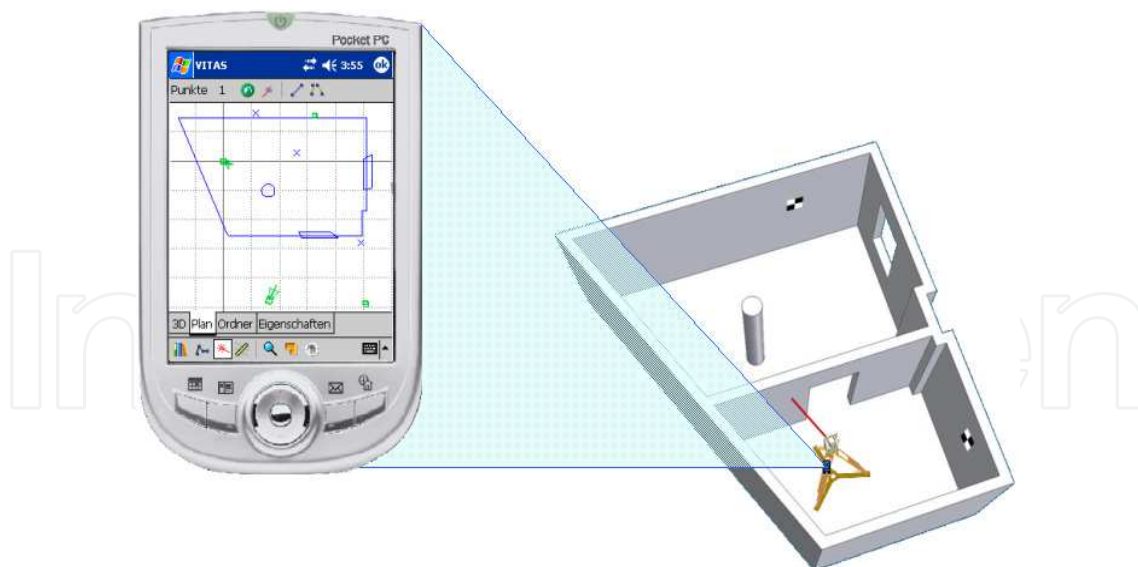

Fig. 6. Building survey with a total station combined with a computer (<http://www.vitruvius.de/software/index.html>)

transformed to a geometry model using dedicated measurement software. Building data (including semantics and attribute data), are captured and constructed simultaneously. Additionally, the graphical output of the software allows an easy visual controlling of the measurement.

#### 4.2 Post processing

The measurement software used for data capturing generally creates automatically a three-dimensional wireframe graphic. For the correct processing of geometric, semantic, and topological building data a 3D volume model of the building is necessary. With a built-in export tool the drawing can be exported directly into CAD (Computer Aided Design) software and converted into a 3D volume model. With the constructive functions of the CAD program 3D geo data can be generated, modified, and visualised.

#### 4.3 Storage and management in a geometrical-topological data model

In a CAD system, data is stored usually in CAD formats (e.g. dxf, dgn, dwg). CAD formats show the disadvantage of restricted further processing. Only single user access to the building model data is possible. Furthermore, CAD systems are not compatible with each other. In the exchange of data information cannot be read and may be lost. In addition, CAD formats generally do not support thematic or topological information for analysis and simulations. For this reason the building data is to be stored in an object-relational geo database where all building information (including geometry and semantic) can be organised and managed. AutoCAD Map 3D from Autodesk (<http://usa.autodesk.com/autocad-map-3d/>) is an example of CAD software allowing connection to a geo database system. This makes it feasible to create, visualise, and save building information in a database contemporaneously. For the external storage and management of spatial data, AutoCAD Map 3D use open source technology FDO (Feature Data Object), which allows direct access to several data formats and databases.

Oracle is a widespread database management system used for the storage and management of different information types. Additionally, Oracle provides a spatial extension *Oracle Spatial*, which offers tools for the storage of three-dimensional geometries (Brinkhoff, 2005; Oracle, 2009). In this case the building elements are stored by use of the special geometry data type from Oracle Spatial. However this geometry data type, also called *SDO\_GEOMETRY*, does not include the spatial relationships to other elements. Shared points, lines, surfaces, and solids which belong to several objects are stored multiply, see picture 7.

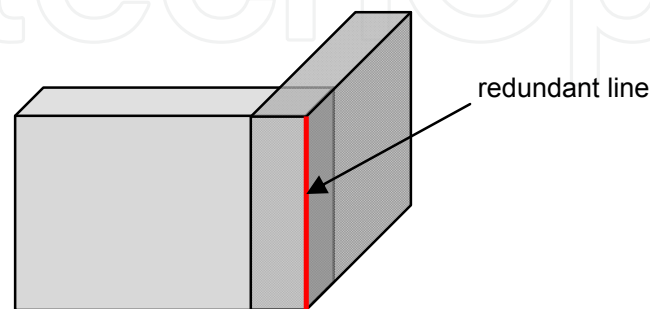

Fig. 7. Redundancy

This leads to redundant data storage, raising the data volume, and the risk of inconsistencies in stored data. *SDO\_GEOMETRY* possesses no topographical information. Neighbourhood analyses are thus possible only with time consuming calculations. As a result, an extended geometrical-topological data model is developed which saves the geometry, semantic, and topology efficiently and allows the export into the CityGML data format (refer Subchapters 4.3.1 and 4.3.2). With the help of Java, the stored CAD data can be converted into the extended CityGML data model. For this, the Java application establish a connection to the database (e.g. about Java Database Connectivity, JDBC), queries the corresponding data, divides the Oracle geometry type in his topological primitives, and stores all in the extended CityGML data model.

#### 4.3.1 Semantic data model

The semantic data model based on the CityGML building schemata (see Fig. 8) is to ensure the output of the building data in CityGML format. All building features as such as rooms, building installation, building furniture, and building properties are realised as tables and attributes. Database relationships describe the link between the features.

#### 4.3.2 Geometric-topological data model

The semantic data model will be supplemented with a geometric-topological data model. This geometric-topological model is based on the concept of Boundary Representation (B-Rep). B-Rep is a description method for vector data and describes three-dimensional solids with topological primitives (see Fig. 9). A solid consists of limiting faces. The face, in turn, is bonded with edges and an edge is defined through two vertices which carry the geometrical information in the form of Cartesian coordinates  $(x,y,z)$ .

Oracle provides a tool for the storing of topological data (*SDO\_TOPO*), but it works in current version 11g only with two dimensional objects and cannot be used in a 3D geo information system. In this case, the topological primitives (solid, face, edge, node) are realised as tables and linked together with relationships. With these database relationships, neighbourhood relations between building objects can be detected, because adjacent building objects refer to the same primitives.

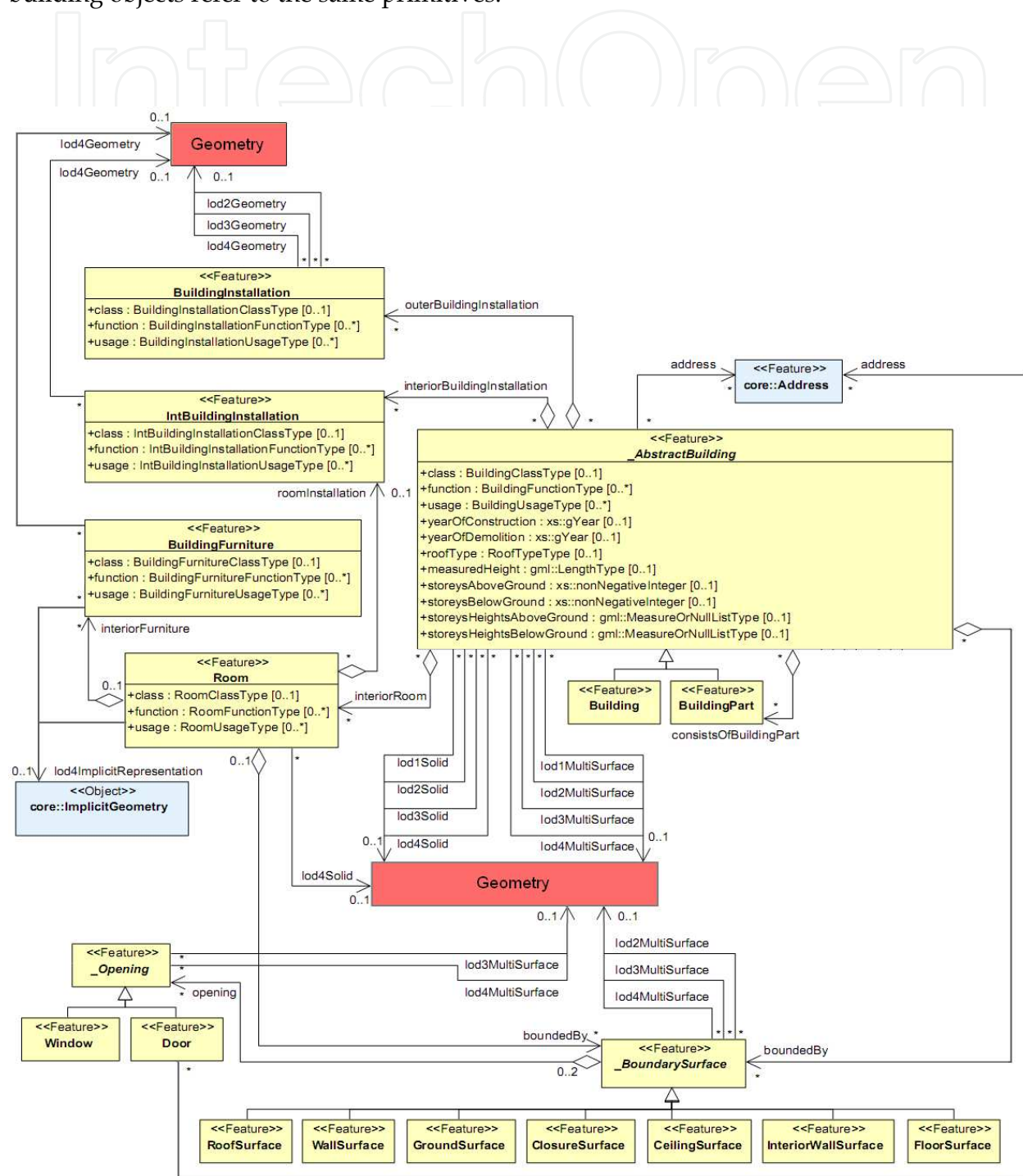

Fig. 8. Extended CityGML-Database-schema (in according to Gröger et al., 2008)

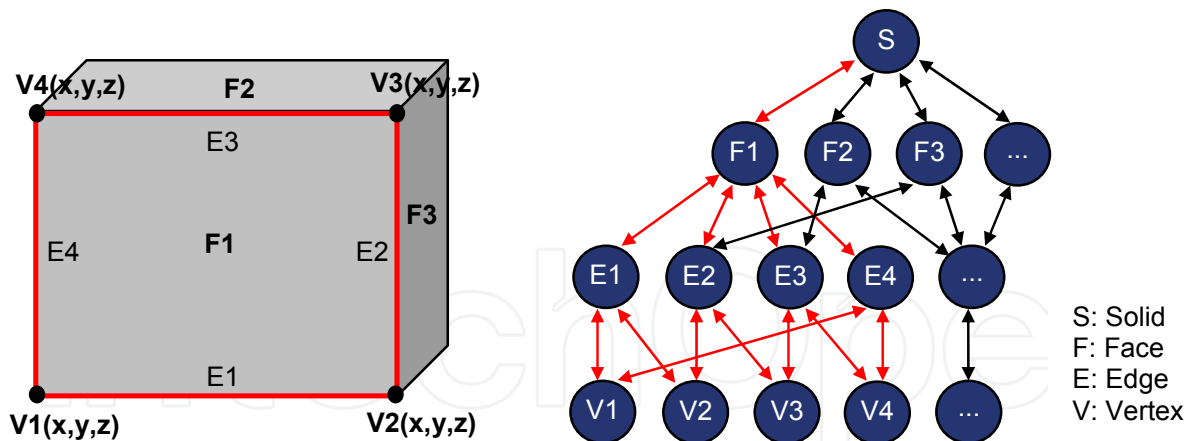

Fig. 9. Concept of Boundary Representation

#### 4.4 Provision

For the provision of the building data at any time, a Web Feature Service (WFS) which supports CityGML can be used. A Web Feature Service is an OGC Web Service for the provision of vector data in GML format (see Subchapter 3.2.1). CityGML is an application schema of GML. With an Extensible Stylesheet Language Transformation (XSLT) the generated XML output can be converted into CityGML. XSLT is a XML-based language, defined by the World Wide Web Consortium (W3C) for the transformation of XML documents (Tidwell, 2002). With this XSL transformation, XML documents can be transformed in each other format, for example HTML (Hyper Text Markup Language), and ensures the data exchange of several systems.

The Web Feature Service was extended by such a XSL transformation that allows the exporting of the stored building data in a conforming CityGML document or in another format such as IFC (Industry Foundation Classes) for the data change of buildings between different architecture software (Coors & Zipf, 2005), see Fig. 10.

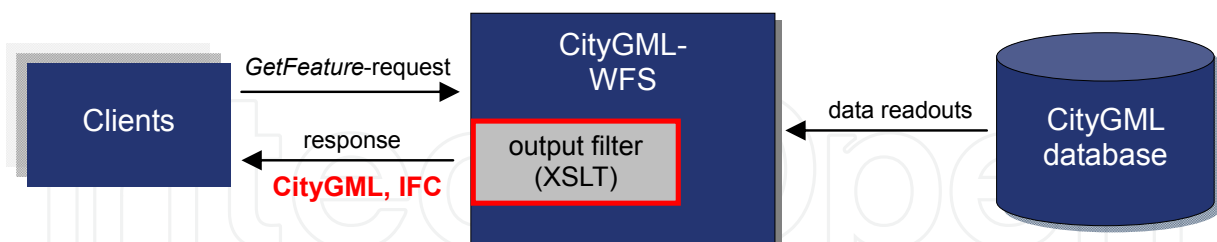

Fig. 10. Communication between client and the database about a Web Feature Service

For the access to the geometrical- topological data model, multiple PL/SQL-scripts are used, which transforms the topological elements into WFS readable geometry objects.

#### 4.5 Visualisation and analysis

The CityGML document can now be visualised and analysed with special viewing software (e.g. LandXplorer). For example, attribute data of each building object (e.g. walls) can be queried for the determination of the energy balance of a building (see example application in Chapter 5). But CityGML is not an efficient graphic format. For the visualisation of 3D

interior building models with less effort formats such as X3D or VRML can be used. In contrast to CityGML, X3D is developed for the visual appearance and performance of the transmittal and display of 3D objects.

With a visualisation service the generated CityGML document can be converted into the X3D format. OGC has developed a series of services which allow a visualisation of three-dimensional geo data. The Web 3D Service (W3DS), see Chapter 3.2.2, is such a visualisation service and able to read and visualise CityGML data in the web when the service contains a CityGML-X3D-converter. At present this service is not OGC standard but an OGC Discussion Paper (see <http://www.opengeospatial.org/standards/dp>). As a result, a bespoke web service as Java EE (Java Enterprise Edition) web application simulating W3DS was developed generating the desired output formats (see Fig. 11).

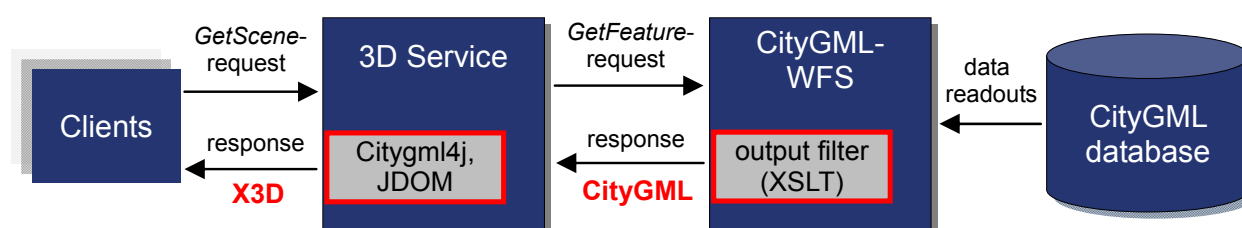

Fig. 11. Transformation from CityGML to X3D

The 3D web service, realised as servlet, requests the CityGML data via the Web Feature Service and transforms this data into the structure of X3D. A servlet is a Java program running in a servlet container (e.g. Tomcat). It receives and answers inquiries from users about HTTP (Hypertext Transfer Protocol). The *GetScene*-parameters of this service has been adapted to the OGC standard. In addition to the parameters *Service*, *Request*, *Layer*, *Version*, and *Format* are offered a *Viewpoint*. This allows the user to specify his/her position and view angle in the 3D scene. Via that viewpoint it is possible to load only visible objects in order to reduce the data volume and response time.

The transformation from CityGML to X3D is realised with the help of Citygml4j and JDOM (Java Document Object Model). Citygml4j is an open source Java application from the Institute for Geodesy and Geoinformation Science of the technical university Berlin (<http://opportunity.bv.tu-berlin.de>) for handling with CityGML documents. JDOM (<http://www.jdom.org/>) creates a tree structure from a XML document in Java and allows the building and manipulation of XML objects. With these two tools, the CityGML building data can be easily read and transformed in X3D with Java.

The generated X3D scene can be saved and visualised with a viewer (e.g. InstantPlayer, Octaga Viewer) or displayed directly in a web browser.

The use of digital information remotely has become matter of fact. Building information can be queried and displayed on-site with mobile devices such as handhelds or mobile phones. A special viewer is necessary given the limited display area, relatively poor graphic performance, and restricted transmission capacity. For that purpose a JavaME (Java Micro Edition) viewer was developed allowing the visualisation of X3D data. JavaME is tailored to the limited scope of functions. For the implementation of 3D applications on mobile devices the Mobile 3D Graphics API (M3G) from JavaME is used. It allows the creation and visualisation of 3D scenes. (Breymann & Mosemann, 2008)

In this process the JavaME application reads and parses the X3D file, creates M3G-objects, renders, and draws directly the 3D scene (Fig. 12). Moreover, it is possible to define additional cameras, lights, and background features for lifelike three-dimensional objects.

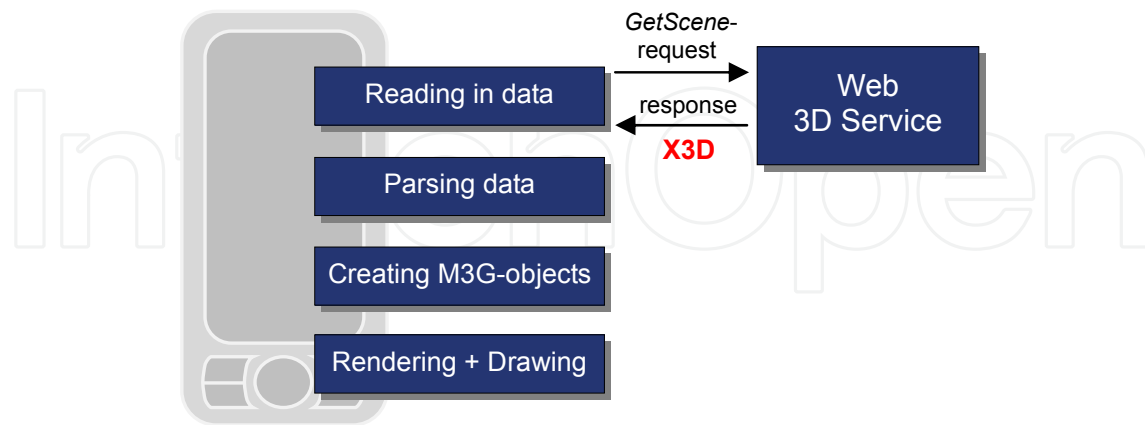

Fig. 12. Mobile devices application with JavaME

## 5. Application example

The three-dimensional building data may be integrated in several applications. The determination of energy balance for buildings in case of restorations or the navigation in a building for rescue teams in case of fire are two examples. In the next chapters, there two example applications describe how the implemented building information system can be used.

### 5.1 Building Information System for energy balances

The German Federal Ministry of Education and Research (BMBF) finances the project "PokIm". PokIm (Portfoliostrategien für kommunale Immobilien, Portfolio Strategies for Municipal Estates) develops strategies for eliminating deficiencies of real estate management. The aim is to save costs, preserve, and build up public real estate. A possible approach is through the improvement of buildings. With the help of renovations, the energy consumption of buildings and corresponding costs (e.g. heating) can be reduced. In order to be able to renovate in the best way possible an energy balance is needed. With energy balances, measures and their effects can be checked. Thus suitable energy and cost savings may be found. For this purpose an geo information system with an accurate building model is needed. This would include information about the internal structure of the building and the building basic fabric (material, heat transfer coefficient, etc.). The developed concept can be used and extended. For the energy balance, properties about building components, how material characteristics, and thermal conductivity are added in the developed model as attributes (see Fig. 13).

The building geo information system was implemented and tested on a building (a villa used as kindergarten). All geometric, topological, and semantic properties were recorded, modelled, and saved. They can be used for the energy balance of this building (see Fig. 14).

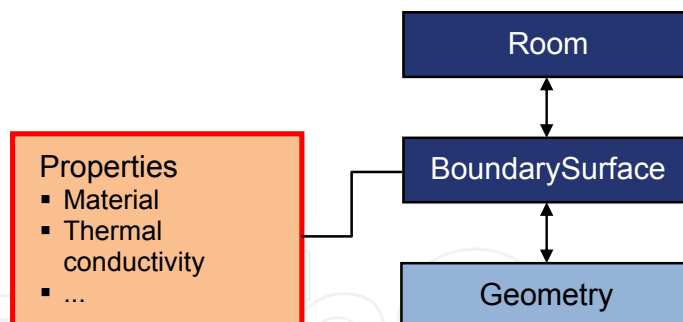

Fig. 13. The expansion of the data model

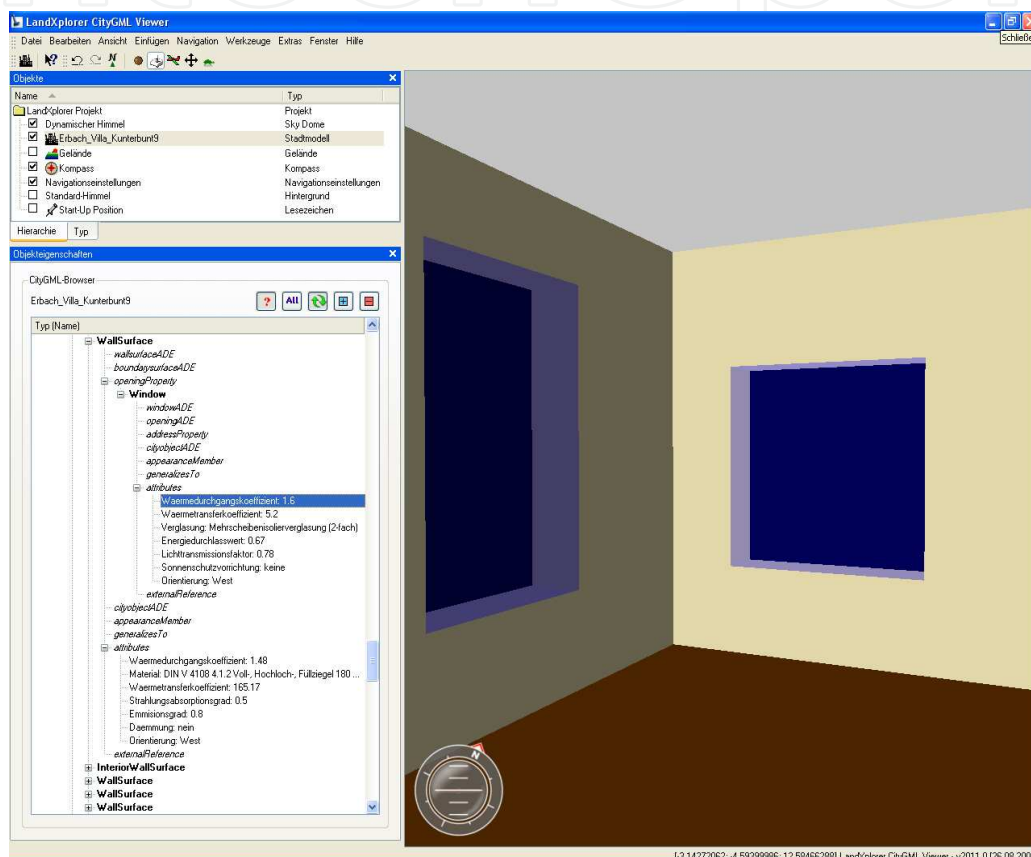

Fig. 14. Simultaneous display of building attribute data and geometry for the determination of the energy balance of a building in Autodesk LandXplorer Software

## 5.2 Distributed Building Information Systems and Indoor Location Services

The availability of semantic 3D building models and the use of open geo standards (CityGML, WFS, W3DS etc.) previously described allows the interoperable access to building information at every time. Thus, modern web-based and distributed building information systems may grow up from which many applications may benefit from. A selection of possible applications is already mentioned in Section 1.

Interesting kinds of applications in this context are mobile applications which allow the providing of building information on mobile devices (e.g. smartphones) at any time or place. Combining these mobile applications with localisation technology for determining the users



geolocation inside the building automatically (Indoor Positioning), Location-based services or, expressed more precisely, *Indoor Location Services* could be developed (Fig. 15). Indoor location services are meant in this context as applications which provide information or other services based on a position determination in indoor environments. Generally indoor location services address mobile applications using portable devices like handhelds or smartphones.

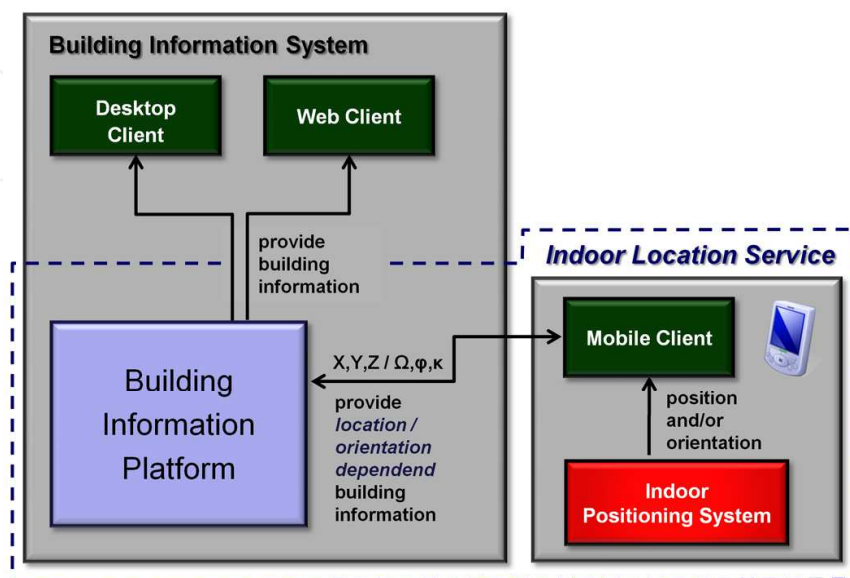

Fig. 15. Indoor Location Services resulting from the combination of building information systems with indoor positioning systems

### 5.2.1 Indoor positioning

Although indoor positioning is still a young field of research many localisation prototypes and systems already exist. Many of those systems utilise a permanent installed localisation infrastructure like reference stations or beacons inside the building and apply radio waves (e.g. WLAN, RFID) or ultrasound for localisation of a mobile station. Autonomous systems in turn detect existing physical forces respectively fields and utilise low-cost sensors (e.g. inertial sensor units, electronic compasses, barometer) often embedded in a mobile sensor module for position estimation. Occasionally both approaches are combined in a kind of hybrid position system. An overview of indoor positioning techniques and systems can be found at Benschky (2008), Kolodziej & Helm (2006), Koyuncu & Yang (2010) and Liu et al. (2007).

In the following a software architecture design for indoor location-based applications is described using the developed concept of a building information system. An augmented reality prototype as one application of the developed concept is then introduced.

### 5.2.2 Architecture for Indoor Location Services

The software architecture of indoor location services resembles commonly used web applications as a distributed software system. Following the concept described in Sections 4.4 and 4.5 a three tier web application was conceived.

The server side of the developed architecture contains the *web* and *data tier* bundled to the building information platform (Fig. 16). The web tier is composed of some chained geo web

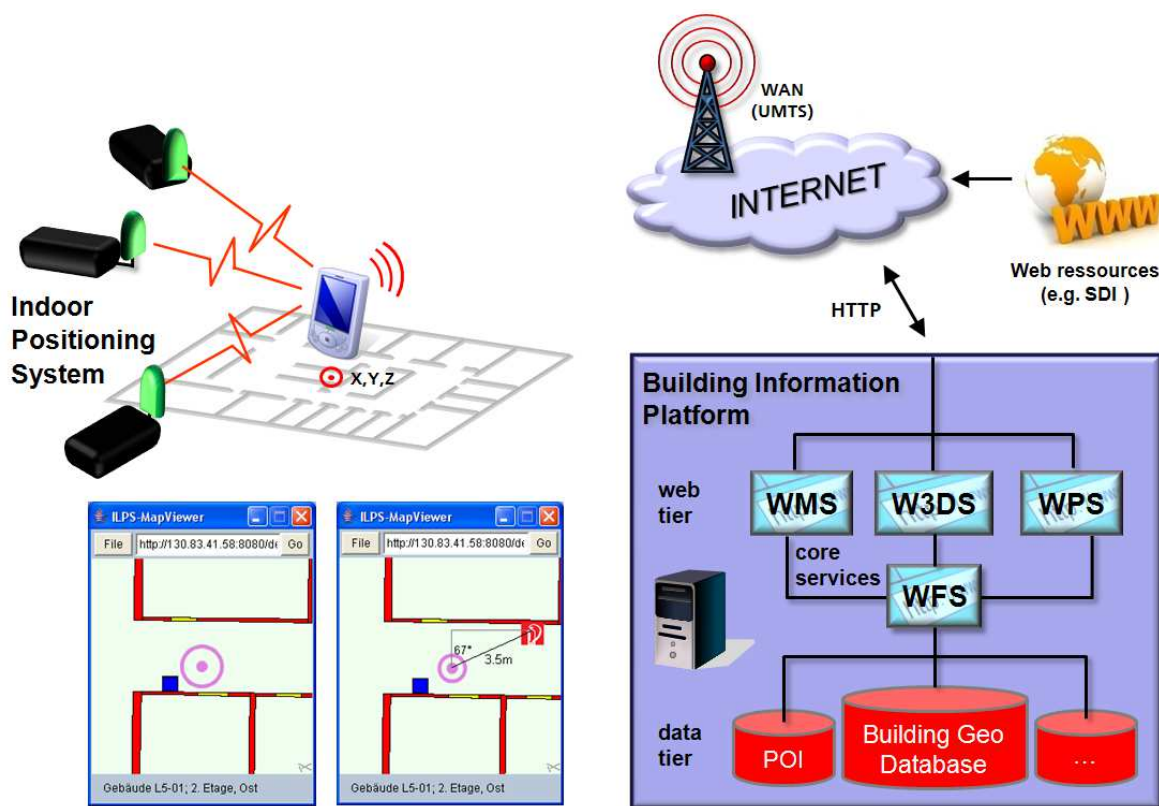

Fig. 16. Software architecture for indoor location services based on geo web services and building geo databases

services like a WMS for the dynamic generation of 2D floor maps, a WFS providing all building and POI data in GML format and a W3DS for the delivery of 3D visualisation models. In addition, a Web Processing Service (WPS), an additional OGC geo web service is embedded and able to offer any geospatial processing task. These core services of the architecture design represent the server side application logic. An additional feature of this concept is the service chaining meaning that WMS, W3DS and WPS access the WFS as a client for querying all desired building data.

The data tier contains the geo databases for all information needed; the building data stored in geometric-topological datamodel (cf. Section 4.3), the point of interest as well as all further required information.

It is conceivable that more and more building data and services will be available over standardised web interfaces. These web resources may also be accessed by an indoor location service over the building information platform.

The client side of the system is a software interface running on handheld, laptop, or any other kind of (typically mobile) device equipped with a wireless communication interface for establishing an internet connection and access to the building information platform.

The software architecture design described was implemented for location services in a building on the university campus. The client side was implemented as a software application for a handheld device developed with JavaME with interfaces to the core services of the building information platform. The main component of the client is the map viewer (Fig. 16) for

- rendering 2D floor plans derived from the WMS
- visualisation of the user's position determined with the indoor positioning system
- display the POIs requested from the WFS and their relative position derived from the WPS.

For further information and more detailed description of possible mobile user scenarios of the building information platform see Blankenbach & Norrdine (2010).

### 5.2.3 Indoor augmented reality

As one implementation of an indoor location services a prototype of an augmented reality application for inspection and maintenance tasks was developed. Augmented reality means the merging of real and virtual world, for example by displaying virtual objects (e.g. power lines located inside walls) or texts (e.g. names, descriptions) in a picture taken by a digital camera.

Here a calibrated web cam is used for capturing the real world that is overlaid by a rendered scene of the building model stored in the building information platform.

The positioning and orientation determination of the web cam is done by a self-developed indoor local positioning system. The basic technology of this system is Ultra Wide Band (UWB), a broadband radio technology which shows positive characteristics for indoor positioning (e.g. the ability to penetrate building materials like walls). The developed position system - so called UWB-ILPS - allows the precise position determination of a mobile station equipped with UWB inside a building. Therefore UWB reference stations with known coordinates are placed indoor. By measuring the time of flight of UWB signals exchanged between the reference stations and the mobile station, the unknown position can be determined by means of lateration. More detailed information about UWB-ILPS can be found at Blankenbach et al. (2009) and Blankenbach & Norrdine (2010).

For the determination of the 3D position and orientation (pose) of the web cam the measurement system shown in Figure 17 was used. A UWB mobile station was equipped

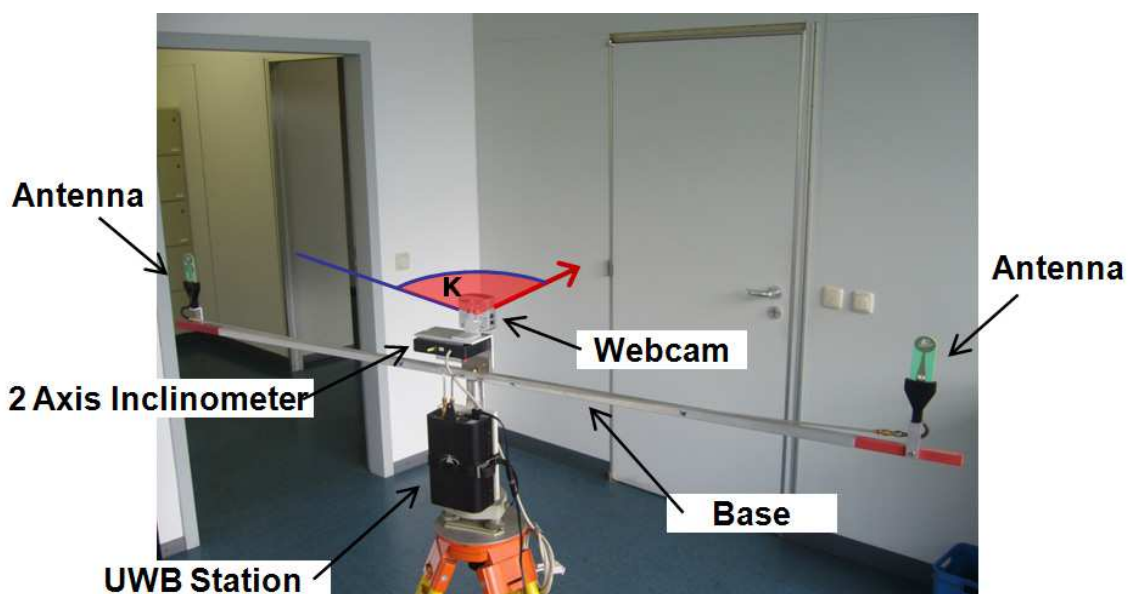

Fig. 17. Prototype of indoor augmented reality measurement system

with a base in the middle on which the web cam was adapted. At the ends of the base two antennas connected to the UWB mobile station were mounted. By determining the 3D position of the two antennas the 3D position and the yaw angle of the camera can be determined directly. To find out the two missing degrees of freedom (roll and pitch angle) an inclinometer as additional sensor is used.

For the control of the augmented reality application a software module with an interface to the UWB-ILPS system was implemented. The pose estimation of the camera is done continuously and for every new estimation the W3DS of the building information platform is queried by sending an http request with the pose as parameters. As result, a 3D scene in VRML format (Fig. 18, left) is received and overlaid with the taken web cam picture (Fig. 18, right) by the developed software client.

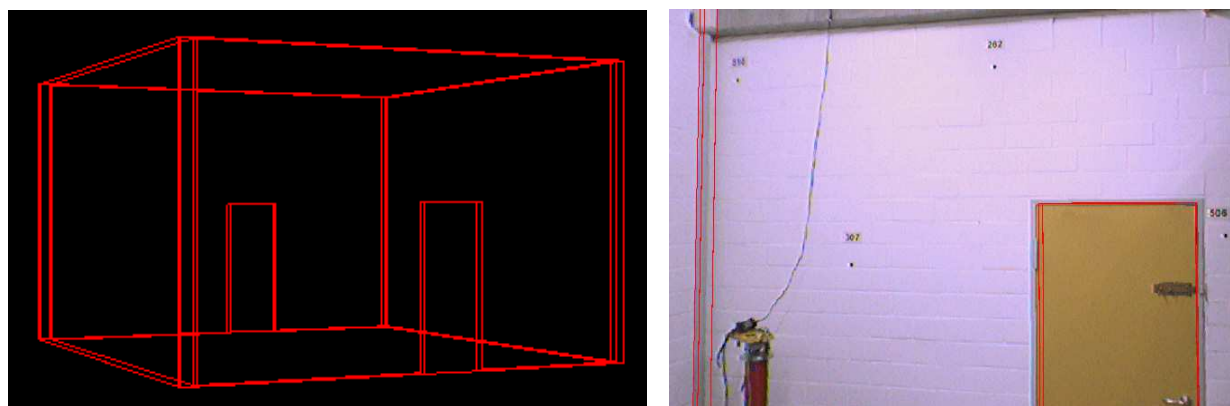

Fig. 18. Augmented Reality based on CityGML building models: Simplified interior room model (left); By a precise indoor positioning system oriented web cam picture overlaid with the room model

## 6. Conclusion

With this closed concept three-dimensional building models can be managed and provided efficiently. Furthermore, with the involvement and combination of additional information, the system can be used for analysis, planning, and control of building processes.

Utilising mobile information technology the building data can be queried anywhere using World Wide Web combined with mobile devices. These allow the user to access information about the building in real time and also on-site.

The advantage of this implementation of a building GIS has optional expandability. It can be realised in other data formats and the system can be linked with modern web services. The data model can be extended with additional data to accomplish a series of tasks like improved documentation and analysis for facility management (e.g. energy balance Fig. 14), inspection, maintenance issues, or logistics. If it is possible to obtain the location within the building (indoor positioning), a variety of new applications can be realised that were not feasible previously (e.g. pedestrian navigation, indoor location services, augmented reality Fig. 18).

## 7. References

- Bensky, A. (2008): *Wireless Positioning – Technologies and Applications*, Artech House, Norwood, Massachusetts, USA
- Blankenbach, J. & Norrdine, A. (2010): *Building Information Systems based on Precise Indoor Positioning*. Journal of Location Based Services, Volume 5, Issue 1, Taylor & Francis, London, pp. 22-37. Available at <http://www.tandfonline.com>
- Blankenbach, J.; Norrdine, A. & Willert, V. (2009): *Ultra Wideband Based Indoor Positioning – A Localization Prototype for Precise 3d Positioning and Orientation*. Grün/Kahmen (Eds.): *Optical 3-D Measurement Techniques IX*, Volume II, 2009, Pp.179-188, Self-Published, Vienna, Austria
- Bleifuss, R. (2009). *3D-Innenraummodellierung, Entwicklung und Test einer CityGML-Erweiterung für das Facility Management*, Technische Universität München, Institut für Geodäsie, GIS und Landmanagement, Fachgebiet Geoinformationssysteme, Diplomarbeit, unpublished
- Breymann, U. & Mosemann, H. (2008). *JavaME, Anwendungsentwicklung für Handys, PDA und CO*, Hanser Verlag, München, Germany
- Brinkhoff, T. (2005). *Geodatenbanksysteme in der Theorie und Praxis - Einführung in objektrelationale Geodatenbanken unter besonderer Berücksichtigung von Oracle Spatial*, Wichmann Verlag, Heidelberg, Germany
- Coors, V. & Zipf, A. (2005). *3D-Geoinformationssysteme - Grundlagen und Anwendung*, Wichmann Verlag, Heidelberg, Germany
- Gröger, G.; Kolbe, T. H.; Czetwinski, A. & Nagel, C. (2008). *OpenGIS® City Geography Markup Language (CityGML) Encoding Standard*, Version 1.0.0, Doc. No. OGC 08-007r1, 16.08.2011, Available at <http://www.opengeospatial.org/standards/citygml>
- Liu, H.; Darabi, H.; Banerjee, P. & Liu, J. (2007): *Survey of Wireless Indoor Positioning Techniques and Systems*. IEEE Transactions on Systems, Man and Cybernetics, Part C: *Applications and Reviews*, Vol. 37, No. 6, (Nov. 2007)
- Kolodziej, K. & Hjelm, J. (2006): *Local Positioning Systems – LBS Applications and Services*. Taylor & Francis
- Koyuncu, H. & Yang, S.H. (2010): *A Survey of Indoor Positioning and Object Locating Systems*. IJCSNS International Journal of Computer Science and Network Security, Vol.10 No.5, (May 2010)
- Pomaska, G. (2007). *Web-Visualisierungen mit Open Source - Vom CAD-Modell zur Real-Time-Animation*, Wichmann Verlag, Heidelberg, Germany
- Oracle (2009). *Oracle Spatial Developer's Guide, 11g Release 1 (11.1)*, part Number B28400-05, 23.09.2011, Available at [http://download.oracle.com/docs/cd/B28359\\_01/appdev.111/b28400/toc.htm](http://download.oracle.com/docs/cd/B28359_01/appdev.111/b28400/toc.htm);
- Schilling, A. & Kolbe, T. H. (2010). *Draft for Candidate OpenGIS Web 3D Service Interface Standard*, OpenGIS Discussion Paper, Version 0.4.0, Doc. No. OGC 09-104r1, 17.10.2011, Available at <http://www.opengeospatial.org/standards/dp>
- Tidwell, D. (2002). *XSLT*, O'Reilly Verlag, Köln, Germany
- Vretanos, P. A. (2005). *Web Feature Service Implementation Specification*, Version 1.1.0, Doc. No. OGC 04-094, 18.08.2010, Available at <http://www.opengeospatial.org/standards/wfs/>

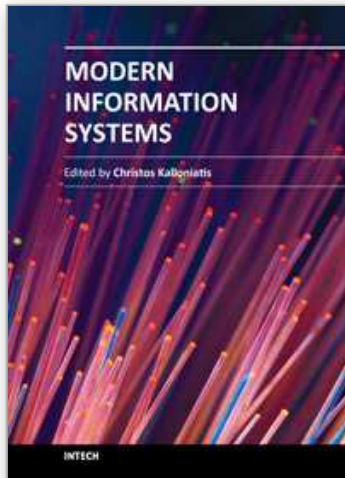

## **Modern Information Systems**

Edited by Dr. Christos Kalloniatis

ISBN 978-953-51-0647-0

Hard cover, 166 pages

**Publisher** InTech

**Published online** 13, June, 2012

**Published in print edition** June, 2012

The development of modern information systems is a demanding task. New technologies and tools are designed, implemented and presented in the market on a daily bases. User needs change dramatically fast and the IT industry copes to reach the level of efficiency and adaptability for its systems in order to be competitive and up-to-date. Thus, the realization of modern information systems with great characteristics and functionalities implemented for specific areas of interest is a fact of our modern and demanding digital society and this is the main scope of this book. Therefore, this book aims to present a number of innovative and recently developed information systems. It is titled "Modern Information Systems" and includes 8 chapters. This book may assist researchers on studying the innovative functions of modern systems in various areas like health, telematics, knowledge management, etc. It can also assist young students in capturing the new research tendencies of the information systems' development.

### **How to reference**

In order to correctly reference this scholarly work, feel free to copy and paste the following:

Jörg Blankenbach and Catia Real Ehrlich (2012). Building Information Systems - Extended Building-Related Information Systems Based on Geospatial Standards, Modern Information Systems, Dr. Christos Kalloniatis (Ed.), ISBN: 978-953-51-0647-0, InTech, Available from: <http://www.intechopen.com/books/modern-information-systems/building-information-systems-extended-building-related-information-systems-based-on-geospatial-s>

**INTECH**  
open science | open minds

### **InTech Europe**

University Campus STeP Ri  
Slavka Krautzeka 83/A  
51000 Rijeka, Croatia  
Phone: +385 (51) 770 447  
Fax: +385 (51) 686 166  
[www.intechopen.com](http://www.intechopen.com)

### **InTech China**

Unit 405, Office Block, Hotel Equatorial Shanghai  
No.65, Yan An Road (West), Shanghai, 200040, China  
中国上海市延安西路65号上海国际贵都大饭店办公楼405单元  
Phone: +86-21-62489820  
Fax: +86-21-62489821

© 2012 The Author(s). Licensee IntechOpen. This is an open access article distributed under the terms of the [Creative Commons Attribution 3.0 License](#), which permits unrestricted use, distribution, and reproduction in any medium, provided the original work is properly cited.

IntechOpen

IntechOpen