

We are IntechOpen, the world's leading publisher of Open Access books Built by scientists, for scientists

4,800

Open access books available

122,000

International authors and editors

135M

Downloads

Our authors are among the

154

Countries delivered to

TOP 1%

most cited scientists

12.2%

Contributors from top 500 universities



WEB OF SCIENCE™

Selection of our books indexed in the Book Citation Index
in Web of Science™ Core Collection (BKCI)

Interested in publishing with us?
Contact book.department@intechopen.com

Numbers displayed above are based on latest data collected.

For more information visit www.intechopen.com



Biosensors and Their Principles

Ahmet Koyun¹, Esmâ Ahlatcıoğlu¹ and Yeliz Koca İpek²

¹*Yıldız Technical University, Science and Technology Application and Research Center,*

²*Tunceli University, Faculty of Engineering, Department of Chemical Engineering,
Turkey*

1. Introduction

Biological and biochemical processes have a very important role on medicine, biology and biotechnology. However, it is very difficult to convert directly biological data to electrical signal, the biosensors can convert these signals and the biosensors over this difficulty. In recent years, thanks to improved techniques and devices, the usage of these products have increased.

The first biosensor was described in 1962 by Clark and Lyons who immobilized glucose oxidase (GOD) on an amperometric oxygen electrode surface semipermeable dialysis membrane in order to quantify glucose concentration in a sample directly [1, 2]. They described how "to make electrochemical sensors (pH, polarographic, potentiometric or conductometric) more intelligent" by adding "enzyme transducers as membrane enclosed sandwiches".

According to a recently proposed IUPAC definition [3], " A biosensor is a self-contained integrated device which is capable of providing specific quantitative or semi-quantitative analytical information using a biological recognition element (biochemical receptor) which is in direct spatial contact with a transducer element. A biosensor should be clearly distinguished from a bioanalytical system, which requires additional processing steps, such as reagent addition. Furthermore, a biosensor should be distinguished from a bioprobe which is either disposable after one measurement, i.e. single use, or unable to continuously monitor the analyte concentration".

A biosensor is a device composed of two elements:

1. A bioreceptor that is an immobilized sensitive biological element (e.g. enzyme, DNA probe, antibody) recognizing the analyte (e.g. enzyme substrate, complementary DNA, antigen). Although antibodies and oligonucleotides are widely employed, enzymes are by far the most commonly used biosensing elements in biosensors.
2. A transducer is used to convert (bio)chemical signal resulting from the interaction of the analyte with the bioreceptor into an electronic one. The intensity of generated signal is directly or inversely proportional to the analyte concentration. Electrochemical transducers are often used to develop biosensors. These systems offer some advantages such as low cost, simple design or small dimensions. Biosensors can also be based on gravimetric, calorimetric or optical detection [1].

Biosensors are categorized according to the basic principles of signal transduction and biorecognition elements. According to the transducing elements, biosensors can be classified as electrochemical, optical, piezoelectric, and thermal sensors [3]. Electrochemical biosensors are also classified as potentiometric, amperometric and conductometric sensors.

The application of biosensor areas [4] are clinic, diagnostic, medical applications, process control, bioreactors, quality control, agriculture and veterinary medicine, bacterial and viral diagnostic, drug production, control of industrial waste water, mining, military defense industry [5], etc. A few advantages of biosensors are listed below:

1. They can measure nonpolar molecules that do not respond to most measurement devices
2. Biosensors are specific due to the immobilized system used in them
3. Rapid and continuous control is possible with biosensors
4. Response time is short (typically less than a minute) and
5. Practical

There are also some disadvantages of biosensors:

1. Heat sterilization is not possible because of denaturization of biological material,
2. Stability of biological material (such as enzyme, cell, antibody, tissue, etc.), depends on the natural properties of the molecule that can be denaturalized under environmental conditions (pH, temperature or ions)
3. The cells in the biosensor can become intoxicated by other molecules that are capable of diffusing through the membrane.

2. Recent development topics on biosensors

In biosensor development studies, suitable bioreceptor molecule, suitable immobilization method and transducer should be selected firstly. Biology, biochemistry, chemistry, electrochemistry, physics, kinetics and mass transfer knowledge is required for this study. Thus we can say that developing a biosensor is related with a interdisciplinary study. Proportional to the technological development and increase of interdisciplinary studies biosensors are being more useful and having more usage areas day by day. Recent development topics which are listed below will be discussed in this chapter:

- Electrochemical biosensor
- Fiber-optic biosensor
- Carbon Nanotube
- Protein Engineering for biosensors
- Wireless Biosensors Networks

2.1 Electrochemical biosensors

Bioelectroanalysis with electrochemical biosensors is a new area in rapid development within electroanalysis. In biosensor development studies, suitable bioreceptor molecule, suitable immobilization method and transducer should be selected firstly. Bioelectroanalytical sensors permit the analysis of species with great Specificity, very rapid, sensitive, highly selective and cheap cost in principle. They can be used in clinical analysis,

in on-line control processes for industry or environment, or even in vivo studies [6]. The difference between biosensor and physical or chemical sensors is that its recognition element is biological.

The investigated bioelectrochemical reaction would generate a measurable current (amperometric detection), a measurable potential or charge accumulation (potentiometric detection) or measurable conductivity change of a medium (conductometric detection) between electrodes. When the current is measured at a constant potential this is referred to as amperometry. If an electrical current is measured while controlled variations of the potential is being applied, this is named as voltammetry.

Potentiometric, amperometric and conductometric measurement techniques forms the kinds of electrochemical biosensors. Potentiometric sensors have an organic membrane or surface that is sensitive to an analyte. The reaction between them generates a potential (emf) proportional to the logarithm of the electrochemically active material concentration. This potential is compared with the reference electrode potential.

Enzyme immobilized electrodes reacts with substrate and products are detected by electrodes. Amperometric sensors measure the current change resulted by chemical reaction of electroactive materials while a constant potential is being applied. The change of the current is related to the concentration of the species in solution.

Generally biological compounds (glucose, urea, cholesterol, etc.) are not electroactive, so the combination of reactions to produce an electroactive element is needed. This electroactive element leads a change of current intensity. This change is proportional to the concentration of analyte.

Conductometric biosensors can measure the change of the electrical conductivity of cell solution. Most reactions involve a change in the composition of solution. Thus conductometric biosensors can detect any reactive change occurring in a solution.

Electrochemical biosensors have advantages that they can sense materials without damaging the system [7]. The use of biosensors for industrial and environmental analysis [8] is very important. The control of food manufacturing processes, evaluation of food quality, control of fermentation processes and for monitoring of organic pollutants are some of the applications of biosensors. The present popularity of analytical biosensors is due to their specific detection, simple use and low cost. For example an electrochemical biosensor can be used to detect Salmonella and E. coli O157:H7 in less than 90 min. [7]. Electrochemical biosensor studies are performed with electrochemical cells.

Electrochemical Cells

An electrochemical cell is used in electrochemical sensor studies. The electrodes themselves play an important role in the performance of electrochemical biosensors. The electrode material, its surface modification or its dimensions effects the detection ability of the electrochemical biosensor. There are three kinds of electrodes in the electrochemical cell:

- Working electrode
- Reference electrode
- Auxillary (counter) electrode

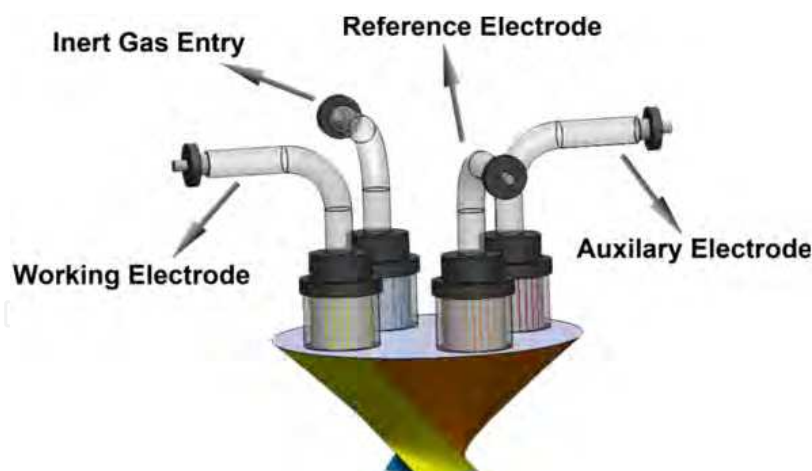

Fig. 1. Electrochemical cell.

Reference electrode:

The other electrodes in the cell are referred to this electrode. Reference electrode types:

- Type 1: the hydrogen electrode
- Type 2: the calomel electrode
- Type 3: glass electrodes

Reference electrode is a kind of standard hydrogen electrode. Hydrogen is potentially explosive and is not very suitable using an electrode with hydrogen gas for routine measurements. So there are two common use and commercially available reference electrode types:

- Ag/AgCl Electrode: There is a Ag wire that coated with AgCl and dipped into NaCl solution.



- Saturated-Calomel Electrode: Calomel is the other name of mercurous chloride (Hg_2Cl_2).

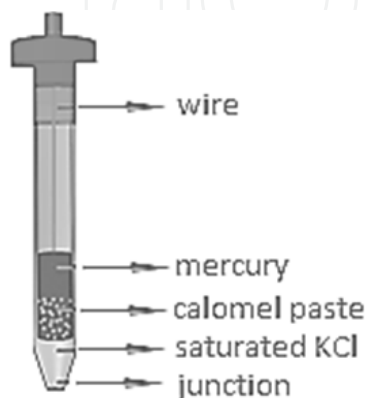
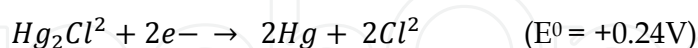

Fig. 2. Reference (calomel) electrode.

Calomel electrode is consist of mercury, paste (mixture of mercury(I) chloride powder and potassium chloride) and saturated potassium chloride solution.

Auxiliary (Counter) Electrode:

In a two-electrode system, when a known current or potential is applied between the working and auxiliary electrodes, the other variables may be measured. The auxiliary electrode functions as a cathode whenever the working electrode is operating as an anode and vice versa. The auxiliary electrode often has a surface area much larger than that of the working electrode. The half-reaction occurring at the auxiliary electrode should occur fast enough not to limit the process at the working electrode. The potential of the auxiliary electrode is not measured against the reference electrode but adjusted to balance the reaction occurring at the working electrode. This configuration allows the potential of the working electrode to be measured against a known reference electrode. Auxiliary electrode is often fabricated from electrochemically inert materials such as gold, platinum or carbon.

Working Electrode:

It is the electrode on which the reaction occur in an electrochemical system [9, 10, 11]. In an electrochemical system with three electrodes, the working electrode can be referred as either cathodic or anodic depending on the reaction on the working electrode is a reduction or an oxidation. There are many kind of working electrodes. Glassy carbon electrode, screen printed electrode, Pt electrode, gold electrode, silver electrode, Indium Tin Oxide coated glass electrode, carbon paste electrode, carbon nanotube paste electrode etc.

Screen printed electrodes are prepared with depositing inks on the electrode substrate (glass, plastic or ceramic) in the form of thin films. Different inks can be used to get different dimensions and shapes of biosensors. Screen-printed electrochemical cells are widely used for developing amperometric biosensors because these biosensors are cheap and can be produced at large scales. This could be potentially used as disposable sensor that decreases the chances of contamination and prevents loss of sensitivity. Figure 3. exhibits an electrochemical biosensor as screen printed electrode.

Performance factors of an electrochemical biosensor are: Selectivity, response time, sensitivity range, accuracy, recovery time, solution conditions and the life time of the sensor.

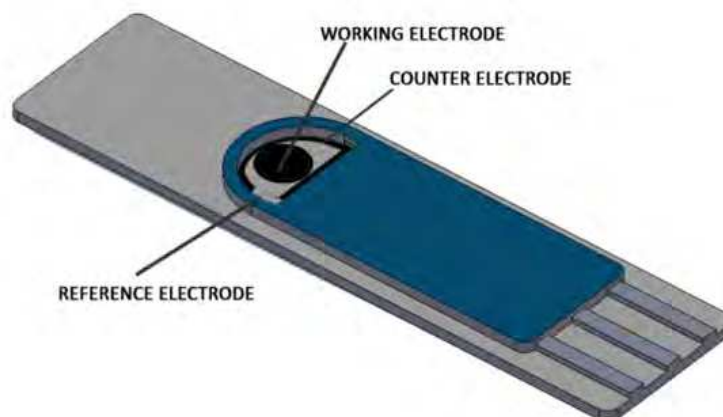

Fig. 3. Electrochemical biosensor as screen printed electrode.

Cyclic voltammetry or CV

Cyclic voltammetry is a type of potentiodynamic electrochemical measurement. In a cyclic voltammetry experiment, the working electrode potential is changed linearly versus time. Cyclic voltammetry experiment ends when it reaches a set potential value. When cyclic voltammetry reaches the set potential, potential ramp of the working electrode is inverted back. This inversion can happen multiple times during a single experiment until a set cycle number is obtained. The plot of the current at the working electrode vs. the applied voltage give the cyclic voltammogram of the reaction. Cyclic voltammetry is a general way to study the electrochemical properties of an analyte in a solution [12, 13, 14].

Chronoamperometry and Chronopotentiometry

A potential is applied to the working electrode and steady state current is measured as a function of time for chronoamperometric measurement. There is a diffusion layer between solution media and electrode surface. The concept of a diffusion layer was introduced by Nernst. Diffusion controls the transfer of analyte from the bulk solution of higher concentration to the electrode. Thus there is a concentration gradient from solution media to the electrode surface. Cottrell equation can indicate this situation better: It defines the current-time dependence for linear diffusion control at an electrode.

$$I = nFAc_0 \sqrt{\frac{D}{\pi t}}$$

I: current is dependent on

F: Faraday's constant,

n: The number of transferred electrons for each molecule,

A: The electrode area,

*c*₀: The analyte concentration,

D: The diffusion coefficient and time

t: Time

Electrochemical Impedance Spectroscopy (EIS)

Electrical resistance can be described as the ability of a circuit element to resist the flow of electrical current. This is defined with Ohm's law:

$$E = I \times R \text{ for DC conditions}$$

While this is a well known equation, its use is limited to only the ideal resistor. An ideal resistor follows Ohm's Law at all current and voltage levels and its resistance value is independent of frequency.

Impedance is a measure of the ability of a circuit to resist the flow of electrical current Like resistance, but electrochemical impedance is usually used by applying an AC potential to an electrochemical cell and then measuring the current through the cell. When we apply a sinusoidal potential, the response to this potential is an AC current signal.

This current signal can be considered as a sum of sinusoidal functions (a Fourier serie). For AC conditions: $E = I \times Z$, where *Z* is the impedance of the system. The impedance can be calculated by setting the input potential and measuring the induced current.

Electrochemical impedance spectroscopy (EIS) is a technique well suited for evaluating coating permeability or barrier properties for corrosion control of steel structures based on the electrical resistance of the coating. EIS has been widely used in the lab to determine coating performance and to obtain quantitative kinetic and mechanistic information on coating deterioration [15].

Detection of Analyte

Detection principle of analytes changes according to transducer type of the biosensor. Electrochemical biosensors use electrical signals as output datas. Thus detection of an analyte is related with the changes of electrical signals. For example; the intensity of the current, potential energy and electrical conductivity of the electrode change.

In cyclic voltametry studies, It is seen that scientists observe the electrical potential vs. electrode current intensity of an electrochemical cell system. When the analyte reacts with a biological component that coated or immobilized on the electrode surface, a change in electrical current occur at an electrical potential array. This current change tells us that there is an electron transfer in the electrochemical cell during the reaction between the analyte and biological component of biosensor electrode. In Figure 4 an example of electrochemical biosensor study for monocrotophos detection with acetyl choline esterase (AChE) enzyme immobilized on a modified glassy carbon electrode (GCE) with Au NanoParticles-SiSG is given below.

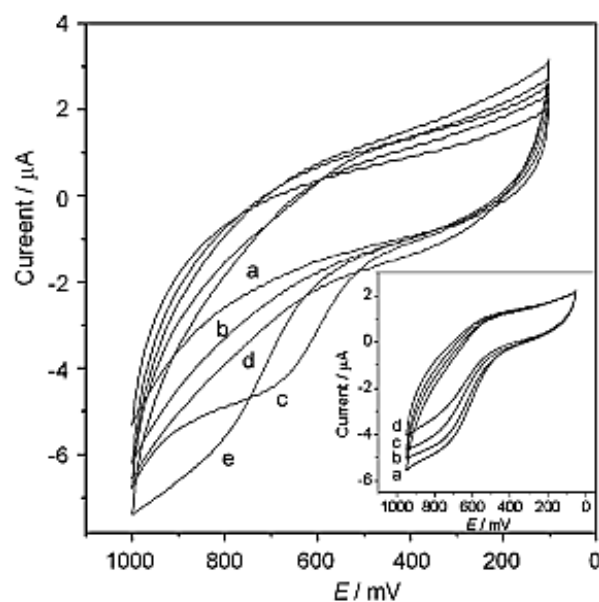

Fig. 4. Cyclic voltammograms of GCE (a) and AChE-AuNPs-SiSG/GCE (b) in pH 7.0 PBS; AChE- AuNPs -SiSG/GCE (c), AuNPs -SiSG/GCE (d) and AChE-SiSG/GCE (e) in pH 7.0 PBS containing 1.0 mM ATCl. Inset: Cyclic voltammograms of AChE-AuNPs-SiSG/GCE in pH 7.0 PBS containing 1.0 mM ATCl after immersed in 0 (a), 0.01 (b), 0.2 (c) and 5 (d) g/ml monocrotophos solution, respectively, for 10 min [16].

The current intensity difference between a and d in inset CV graph gives the result for monocrotophos concentration (the analyte). The inhibition of the enzyme is used for the detection of analyte in this example.

Immobilization methods

Electrochemical detection techniques use predominant enzymes. Because enzymes have specific binding capabilities and biocatalytic activity. Some of the other biorecognition elements are antibodies, nucleic acids, cells and micro-organisms. Biorecognition elements should be immobilized on the electrode surface. Adsorption, microencapsulation, entrapment, covalent attachment and cross linking methods Are the most well known immobilization methods.

Adsorption methods:

1. Physical adsorption (physisorption) and
2. Chemical adsorption (chemisorption).

Physisorption is weaker than chemisorption. Adsorption is the simplest way for immobilization of organic material, however the bonding is weak and life time of electrode is short.

Microencapsulation method is more reliable for adsorption. In this method, an inert membrane traps the biologic material on the working electrode. Most used membranes are cellulose acetate, collagen, glutar aldehyde, chitosan, nafion, polyurethanes, etc..

In entrapment method, generally a solution of polymeric materials are prepared containing biologic material that will be entrapped onto the working electrode. The solution is coated on the electrode with various coating methods. Starch gels, nylon and conductive polymers such as polyaniline or nafion are used for.

Covalent attachment immobilization is important particularly for the advantage that the enzyme is not been released from the electrode surface when it is used. However, covalent bonding should not decompose or hide the active site of the enzyme. The functional groups that may take part in this binding are NH_2 , CO_2H , OH , $\text{C}_6\text{H}_4\text{OH}$ and SH groups. [15].

Cross linking is bonding two or more molecules by covalent bonds. In cross-linking method bifunctional agents such as glutaraldehyde are used to bind the biological materials. The disadvantage of this method is high ratio of enzyme activity loss.

2.2 Fiber optic biosensor

The optical fiber is flexible and has small wires generally made out of glass or plastic in different configuration, shape, and size. It can transmit light signals for long distances with minimum lost value. The optical fiber is convenient for harsh and hazardous environments, because of their remarkably strong, flexible and durable structures. It is non-electrical; therefore, it can be used in various damaged electric current applications. Optical fibers are commonly used because of high quality and its low cost for sensing applications. Particularly, the main attractive properties of optical fibers can permit transmission of multiple signals synchronously and by this means it can obtain multiple capabilities for sensing of analyte [17].

Figure 5 exhibits the optic fibers model that is containing a core and coating. Their refractive indices are n_1 and n_2 , respectively as shown in Figure 6. The core and cladding interference act as mirror because of their different refractive indices (Fig 7a) [17].



Fig. 5. Optic Fiber

The core and cladding parts play a very important role particularly on the light transmission. Their refractive indices are n_1 and n_2 , respectively (Fig 5). In the Fig 6a the core and cladding interference act as mirror because of their different refractive indices. The series of internal reflections transmit the light from one end of the fiber to the other one [17].

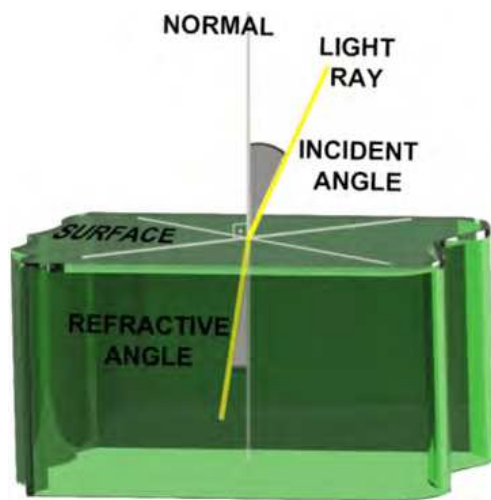

Fig. 6. TIR Principle

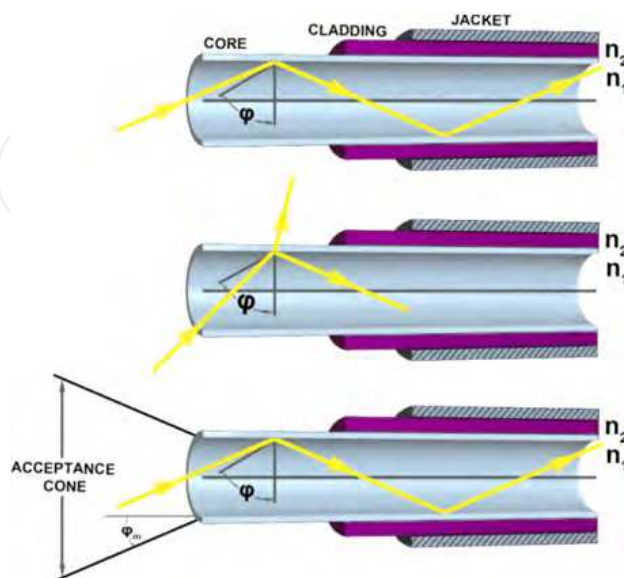

Fig. 7. The lateral section of Fiber Optic and reflection of signal in Fiber Optic

Generally fiber optic biosensors (FOB) work with using total internal reflection (TIR) principle (Fig 6) if two main conditions are satisfied:

i= Compared with the critical angle, larger cladding angle facilitate the reflection of the light and spread it through the fiber.

θ_c = Critical angle

n_0 = Refractive index of medium

n_1 = Refractive index of core

n_2 = Refractive index of cladding

$$\theta_c = n_2 / n_1$$

i. Light angles entering through the fiber should be within the acceptance cone as shown Figure 7c. The acceptance cone angle, θ_m depends on refractive indexes of core, clad and medium.

$$\sin \theta_m = (n_1^2 - n_2^2) / n_0$$

$$\sin \theta_m = \frac{\sqrt{(n_1^2 - n_2^2)}}{n_0}$$

Another parameter is numerical aperture. The relation between numerical aperture and acceptance cone's angle is shown as follow equation:

$$NA = n_0 \sin \theta_m$$

The light collecting capabilities of the fiber is high when the acceptance cone is wide. The larger the NA is, the more powerful optic fiber will be [17].

Fiber Optic is used in optical fiber biosensors that measure some biomolecules such as proteins, nucleic acids etc.) Because of the attractive properties of fiber optic biosensor such as low cost, efficiency, accuracy, these take place of literature and they are preferred in many applications.

The Fiber Optic biosensor provides alternative measurements method to conventional methods for determination of biological species.

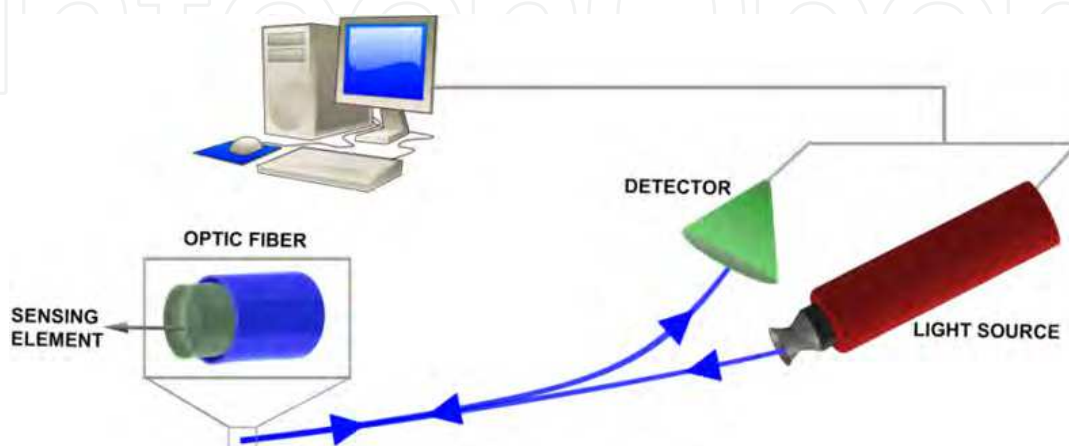

Fig. 8. The Fiber Optic Biosensor

The basic system of a fiber optic biosensor consists of a light source, an optical fiber, sensing material and a detector. An optical fiber transmits the light and also acts as the substrate for the sensing material. Detector measures the output signal. (Fig8) Some light source of optical biosensors are tungsten lamp, deuterium lamp, xenon lamp, LEDs, Laser, Laser diodes and some light detectors for optic biosensors are avalanche photodiodes, photodiodes, photomultipliers, charge-coupled devices [17].

When the reaction occurs between sensing element and the analyte, there is a change both its physico-chemical and optical properties. This transduction mechanism, generates optical signals, is related with analyte concentration. To measure the optical signals, the difference between incident and output light is determined at the location where the sensing element is fixed. Output light is sent to detector by fiber. Collected light (reflected, emitted, absorbed light) is measured on the detector. [17].

The Fiber Optic Biosensor have some advantages and disadvantages which are shown below.

The Advantages of Fiber Optic Biosensor [18, 19]

1. There is no need reference electrode in the system
2. It can be easily moved, because there is no reagent in contact of any optical fiber
3. There are no electrical safety hazards and electrical interference
4. It is less dependent than temperature compared with electrode
5. It can be found in-vivo measurement applications because of easy miniaturization
6. Multiple analytes can be determined thanks to guide the light in different wavelengths at the same time.
7. It can be used for the most of chemical analytes because of its spectroscopic properties.

The Disadvantages of Fiber Optic Biosensor

1. The life time of the reagents can be short under incident light
2. Because of the diffusion of analytes, it may cause slow response time
3. Fiber Optic Biosensor only works for specific reagent.
4. Optimized commercial accessories have limited availability when using them with optical fibers.

The Types of Fiber Optic Biosensors

Absorbance Fiber Optic Biosensor: An atom or a molecule absorbs light energy is called as absorption. The molecule takes this energy and moves to higher excited energy state from ground energy state.

Lambert Beer Law is used for the absorption.

$$A = \log \left(\frac{I_0}{I} \right) = \epsilon \cdot [C] \cdot l$$

A=Optical absorbance

I_0 = incident light intensity

I= transmitted light intensity

l =effective path length

ϵ =Molar absorption coefficient

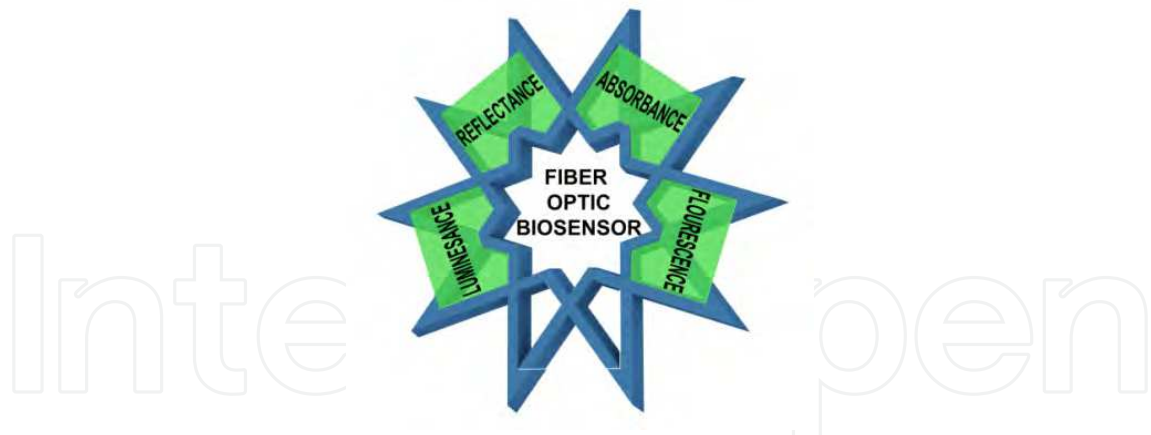

Fig. 9. The types of fiber optic biosensors

Practically, the optical fibers detect the transmitted and scattered light through the fiber and then it can be obtained absorbance values.

Fluorescence Fiber Optic Biosensor: Fluorescence is commonly used in fiber optic biosensors and better than adapted by optical sensors compared to absorption fiber optic biosensors and the other advantage is very sensitive technique that can detect very low concentrations [20].

When the molecule excited, they gain some energy to move to higher energy state which is non-stable state. After that they want to return the ground state because of conservation their steady state. In fluorescence optic fiber biosensors, fluorescence signals are measured by transmitting the excitation light through an optical fiber and the light emission is measured via detector. Generally, it is measured using the change of fluorescence intensity and related to the analyte concentration [17].

Luminescence Fiber Optic Biosensor: Luminescence can be mainly classified by two parts. These are chemiluminescence and bioluminescence. On the contrary to fluorescence, excited species are obtained as yield of chemical reaction and these excited species emit light while returning to the ground state. Aboul- Enein et al. studied chemiluminescence in fiber optic biosensors [21]. The bioluminescence, a biological chemi-luminescent reaction, is produced by many living organisms in nature for mating, self-protection and finding food [22].

As a simple example, if a wide diversity of sequence of biochemical reactions is used, the production of light will increase. This enzymatic reaction is catalyzed by luciferase and liberates a compound in its excited state while it is going back to its ground state.

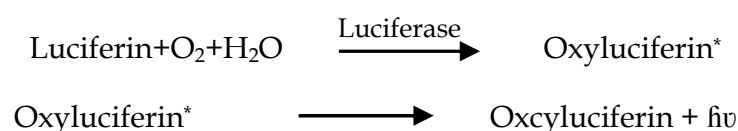

The mechanism of light emission of Oxyluciferin* is similar to fluorescence that can be produced by irradiating oxyluciferin via the standard method

Reflectance Fiber Optic Biosensor: The reflectance fiber optic biosensor works with evanescence waves. Besides transmittance and absorbance, reflectance of analyte is another

measurement method. The reason of reflectance changing is the structure of material. The effect of bio-interface reflectance changes in a large band.

In recent years, fiber optic biosensors has been very useful for the medical technology, dramatically improving patient care and cutting overall operating costs. Nowadays, they are currently used in a variety of medical application such as early cancer and AIDS detection.

2.3 Carbon nanotube biosensor

The most of the scientists have claimed that a coupling of material science and biology in the nanosize will have a remarkable effect on the many fields of science and technology. Particularly in the biology field, nanosize is very important scale because many important biomacromolecules structures are in the range of 1-1000nm. [23]

Because of these reasons, the focus is on nanostructured materials. It helped develop the unique properties of new devices and sensors. These nanostructured materials have good chemical sensitivity, biocompatibility, and good electrical sensitivity with changes of chemical composition. The sensitive materials have played a significant role for the chemical and biological sensor because of their sizes which are close to biomolecules.

The performance and improvement of biosensors highly depend on the materials. Moreover the chosen materials of making transducer are directly related to their physicochemical characteristics.

The carbon materials such as carbon nanotubes (CNTs) are used in making biosensor.

CNT's are well ordered and hexagonal arrangements of Carbon atoms which have been rolled into tubes. It can be considered as the cylindrical graphite layer or layers which have nanometer scale of diameter. Therefore, it can be classified as single wall (SWNT) and multiwall carbon nanotube (MWNT) as structural. The diameter of SWNT is approximately 0.4-2 nm and the other one is 2-100 nm.

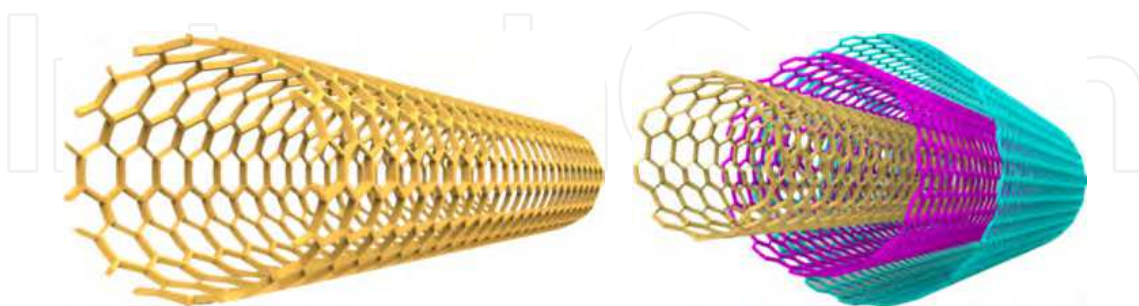

Fig. 10. Single and Multi- walled Carbon Nanotubes, respectively.

They can also be metallic conducting or semiconducting carbon nanotubes which change with geometrical structure. The chiral angle, which determines the twisting value of CNT, play important role on the conductivity of CNTs. It can be called as zig zag, armchair and chiral structure (Fig. 12)

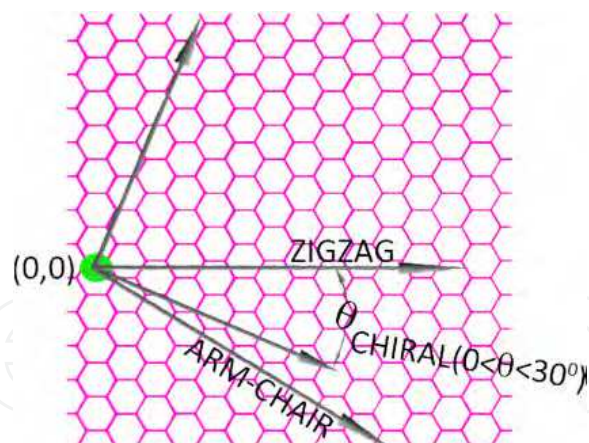

Fig. 11. The unrolled, two-dimensional, honeycomb lattice of a CNT

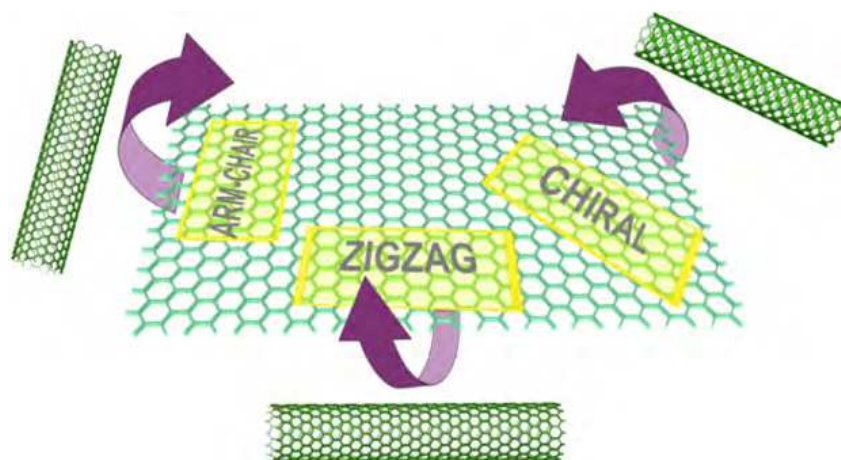

Fig. 12. Classification of CNTs, a) Arm-chair, b) Zig-zag, c) Chiral CNTs

In particular, it was explained the relation with structure and electrical conductivity of SWNTs by some researchers. The studies have shown that arm-chair tubes can be metallic. Beside this, zig-zag and chiral tubes can be either metallic or semiconducting. The conductivity values are related with the wrapping angle and the length of CNTs [24].

The electrical measurements of MWCNTs have shown that the electrical conductivity of MWNTs can be metallic or semiconducting character [24, 25].

Major methods of CNT synthesis are electrical arch discharge, laser vaporization, and chemical vapor deposition (CVD) [26, 27, 28, 29, 30, 31].

CNTs exhibit attracted electrocatalytic activity because of their interesting properties such as their dimension, electronic structure etc [26, 28, 32, 33-35].

Generally, in the voltammetric response of several molecules at electrodes modified with CNTs, higher peak currents and lower overvoltage are observed. Reading the literature, it can be claimed that CNTs is a very challenging materials for the preparation of electrochemical sensors due to these unique properties [26, 36-43].

They have some advantages such as small size, high strength (approximately 100 times higher than the strength of steel), high electrical (approximately 100 times greater than for

copper wires) and thermal conductivity (higher than diamond), high specific surface area, simple preparation, less power, long term stability, good reproducibility, fast response etc. Therefore, CNT has better properties than other materials which are used in making biosensor and the researchers are interested in using CNT for next-generation of sensors. Because of these properties the researchers consider that CNT biosensor has the potential of revolutionizing the sensor area.

The advantages of CNT biosensors help it to perform better in many of the biomedical sensing applications. Therefore, CNT-based biosensors are highly suitable as implantable sensors.

In some studies, the dynamic parameters of biosensor such as response time and sensitivity with either carbon nanotube or without carbon nanotube were investigated. Decreasing of response time and increasing of sensitivity because of increasing electron transfer rate in the presence of the CNTs were reported [44-47]. Moreover, CNT's have excellent catalytic activity which decrease their oxidative potential to avoid fouling problems. The enzymes can be chemically immobilized to materials in the presence of CNT. For all these advantages of CNT biosensors are very convenient device to detect biological molecules.

CNT based Electrochemical Enzymatic Biosensors:

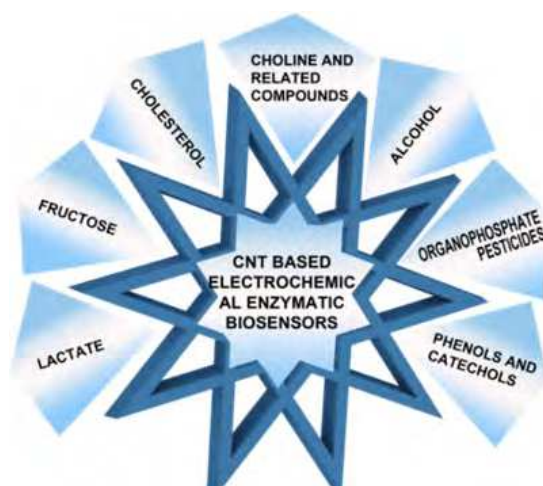

Fig. 13. The Types of Carbon Based Electrochemical Enzymatic Biosensors

Glucose biosensor: Nowadays, the glucose biosensors have an important role for diagnostic and control of diabetes. There are many ways of preparation of glucose biosensors which are made up of carbon nanotubes (CNT). For example, Rubianes and Rivas modified Carbon Nanotube Paste Electrode (CNTPE) with glucose oxidase (GOx). They obtained more sensitive glucose biosensor without redox mediators, metals etc. [26, 48].

The other attractive preparation of glucose biosensor is cross-linking of GOx with SWCNT and poly[(vinylpyridine) Os(bipyridyl)₂Cl^{2+/3+}] polymer film following two alternatives as shown in figure which is done by Schmidtke and co-workers. The first alternative is the SWCNT which was deposited on bare glassy carbon electrode (GCE) and then hydrogel containing the redox polymer and the enzyme for catalytic effect. Second alternative is SWCNT which were developed with enzyme solution after this process it was treat redox hydrogel and then modify with GCE [26, 48-49]. (Fig. 14)

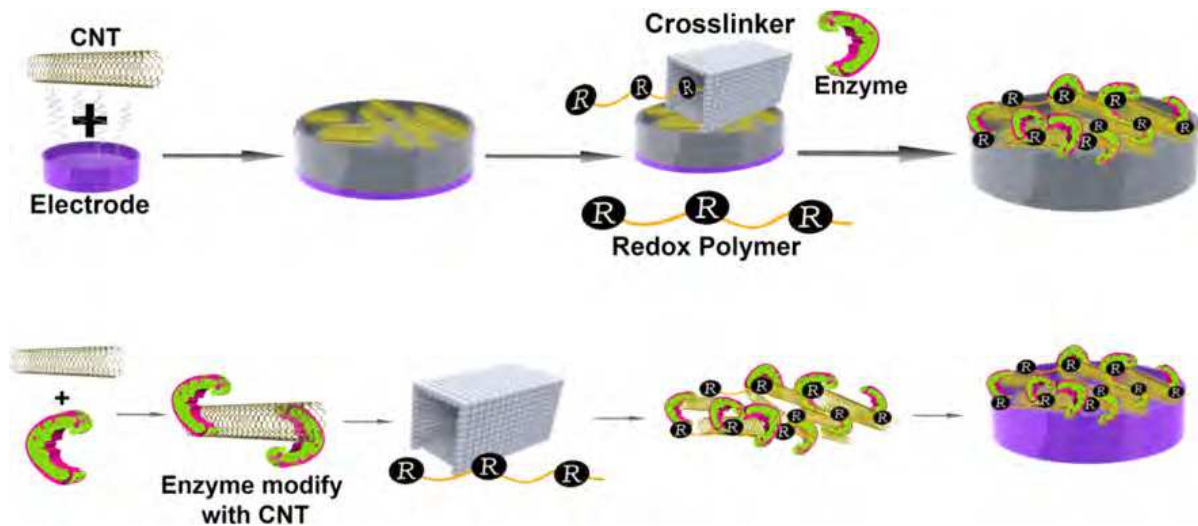

Fig. 14. The example of glucose biosensor based CNT. [35]

b) Fructose biosensor: Fructose is widely distributed monosaccharide and important sweetener because of its sweetening ability. The sweetening ability of glucose and sucrose is lower than that of fructose. The some scientists proposed amperometric biosensor, which was modified with CNTPE for sensing fructose, covered by polymer which is obtained from electropolymerization of dihydroxybenzaldehyde [26, 50].

c) Chlosterol A: The determination of cholesterol levels is of vital importance for some illnesses such as cardiovascular diseases. Chlosterol Biosensor consists of the modification of a screen printed electrodes (SPE) with chlosterol esterase, peroxidase, oxidase and MWCNT was used for determination of total cholesterol in blood with very good sensitivity. The Chlosterol biosensors modified with the carbon nanotubes promoted the electron transfer so as to improve the sensitivity of the sensor [26, 51].

The other biosensors, which are modified with CNTs, are Lactate biosensor, Phenols and catechols, Hydrogen peroxide, Alcohol biosensor, Choline and related compounds, Organophosphate pesticides.

CNT-based-DNA biosensors: The traditional method for sensing DNA and RNA molecules is too slow and requires special preparation. There are some critical points for preparation of DNA biosensor. Most important step is immobilization of DNA probe on the electrode. Media should have special conditions for pH and temperature for preparation of DNA biosensor. [26, 52]

Ye and Ju developed the use of SPE modified with MWCNT. The scientist developed the use of SPE modified with MWCNT. Their DNA biosensor detected the analyte fast and provided sensitive measurement [26, 53].

Fang and co-workers was used a glass carbon electrode (GCE) modified with MWCNT observed an enhanced sensitivity for electrochemical DNA biosensor based on carbon nanotubes. [26, 54]

DNA detection sensitivity of biosensor which is modified with CNT is much higher than conventional DNA sensors [26, 55].

2.4 Protein engineering for biosensors

What is protein engineering?

Protein engineering is the process of controlling the development of useful or valuable proteins. Proteins were used for specific biosensor design. Affinity between protein and analyte is the basic principle of this study area. Scientists, firstly determine the three dimensional crystal structure of the proteins and build a protein data bank. Three dimensional structures of the proteins are obtained with protein crystallization methods. When proteins are immobilized on the electrode surface, the active site of the proteins should be free in three dimensional structures. In some situations mutations can be applied to the active site of the proteins. Therefore, protein structures should be well known.

The interaction between protein and its ligand is determined with different types of transducers. If the presence of very low amounts of biomolecules is determined, various diseases and cancer types can be identified at early stages. Protein engineered biosensors can specifically identify chemical substrates with protein-based sensors. There are three main strategies employed in the engineering of more suitable biological components used in biosensors. These techniques do not exclusive to each other, also they can be applied together. Rational protein design, directed evolution and de novo protein design are the main methods. Each design strategy has limitations, advantages and disadvantages respect to each other to be used in a biosensor format. The three design techniques are used to modify aspects of stability, sensitivity, selectivity, surface tethering, and signal transduction within the biological environment [50].

Rational design of proteins

In rational protein design, the scientists use detailed knowledge of the structure and function of the protein to make desired changes, since site-directed mutagenesis techniques are well-developed. This has the advantage of being inexpensive and technically easy. However, detailed structural knowledge of a protein is often unavailable. When it is available, it can also be extremely difficult to estimate the results of various mutations. Computational protein design algorithm aims to identify amino acid structure sequences. While the conformational sequence structure in the space is large, a fast and accurate energy function is required that it can distinguish optimal sequences from similar suboptimal ones.

Directed evolution:

In directed evolution, mutagenesis method is applied on a protein, and a selection way is used to pick out variants that are quality. This method mimics natural evolution and generally produces superior results to rational design. An additional technique known as DNA shuffling mixes and matches pieces of successful variants in order to produce better results. This process mimics the recombination that occurs naturally. The most important advantage of directed evolution is that there is no need to know structure of a protein, and predict the resultant effect of a mutation. In fact, the results of directed evolution experiments are often surprising. Because the desired changes are often obtained by mutations that were not expected to have that effect. Disadvantage of the method is low throughput. This is not convenient for all proteins [51].

Future Biosensors Directions:

Miniaturization of developed biosensors will be important in the future. Because miniaturization is required for small electrodes, for example measurements in vivo. Another future approach is the combination of biological materials with a silicon chip because it seems to be the most comprehensive integration between biology and electronics [50]. Nanostructures will be important new components in recently developed electrochemical biosensors: Nanowires, carbon nanotubes, nanoparticles and nanorods are some of the familiar objects that are crucial elements of future bioelectronics devices and biosensors [52].

2.5 Wireless biosensors networks

An Aspect of Sensor Communication Networks

Each sensor or device communicating each other and a center with hierarchical protocols and/or functioning algorithms can be defined as a network. Network system which has either wired or wireless network system can access these sensor or device with a path. Even though wireless systems have become common with recent effective developments; some applications require wired network system. Beside this; topology means how network systems connect and operate. Each network system has its own topology. In other words; it is network architecture and is all efforts on hierarchical communication and functions between network members. Also it can be said that it realizes operation protocol (software).

For example; Ethernet is a network topology and TCP/IP is an access protocol. Topology also defines maximum access distance. While physical topology describes how the networks connected each other; logic topology describes how the network members transmit data. Following are some types of networks; commonly used I^2C and CAN BUS network topology; wireless networks and wireless sensor/biosensor network (WBNS). The system included point to point communication in earlier generation networks and the sensor included point to point communication, the sensor was communicating to a center. This communication was developed in 1980's. There were two main problems such as wave quality and cost. Wave quality was not enough and the cost was very high. After that in 1990's networks began to use micro controllers and some kind of sensor processor systems. Generally an analog signal come to this system then it is converted to digital signal and saved signals transmitted by RS 232, RS 422 or 485 protocols. Normally RS 232 works with binary code. The connections of the signal are made from datas to terminal equipment at the same time data circuit terminating equipment [53]. Logic signal is zero or one respectively for zero (+3) - (+15) V and for one, (-3) - (-15) V.

The smart sensor networks use bus system. Bus systems include bus connection system and bus system hierarchical protocol. Whole bits have two open ends. The data speed is 100Kbit/s at standard mode, 400 Kbit/s and 3,4 Mbit/s respectively fast and high speed wave mode. In order to compare to these bus systems, three bus systems are given in below. One of them is inter - integrated circuit I^2C bus, others are CAN BUS and Ethernet Bus protocols of network system topology [53, 54, 55].

I^2C bus network given in Fig.14 is suitable for sensing in short distances and process. Fiber optic or coaxial cable travels between network members in order and data is transmitted to all system at the same time thorough them. The fiber optic cables are using wired fiber optic

sensor network. Since the fiber optic cables have multi wires, data is transmitted very fast. In wired sensor networks require fast transmission; electromagnetic waves are produced. In those networks; each member can send data to network because each member has unique MAC address. Addressed networks can decide whether the data travelling data is belonging to it or not with the help of the MAC number. Each member can manage it through the software on the network [56].

The devices in a network (actuator, sensor, or group of sensors, hd (eeprom) or a processor) can communicate each other. It is impossible to extend the device connection with this generation of sensor networks. In the case of using RS-232; extension problem is relaxed a bit. But usage of finite number of members must be mentioned. When data command send to the related device, the master one pass on receiver mode. Then related device become sender and sends the data to data line. [57] Clock is for reading the data. Bus systems consist hardware and a suitable protocol. In Fig.15 presents the processor sending data to devices (and nodes) with it is protocol.

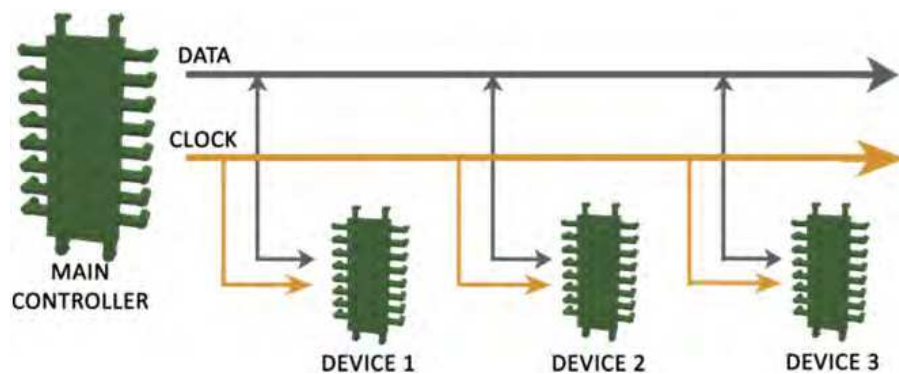

Fig. 15. The bus structure of I^2C

CAN bus is a differential system and works differential if high (logic 1) bigger than low (Logic 0). The differential value is 1. Opposite of this the value is naturally 0. This knowledge can be reached up to 1000 m. RS 422 and RS 485 is also differential. It is used in communication to reach points. The software supports the hierarchical protocol of the system. I^2C and RS 232 protocols are not differential and can be established a network only for short distance communication [58], [59]. Separately CAN differential system has good noise immunity and this system is secure with this side. Can bus system is given below in Figure 16.

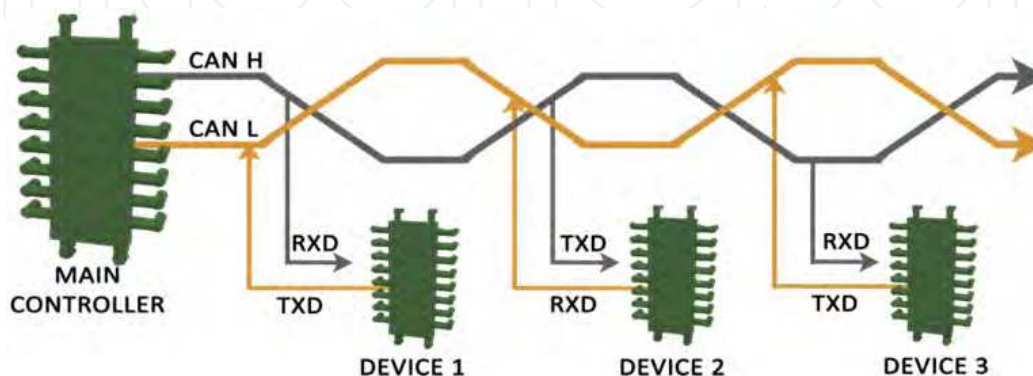

Fig. 16. The structure of Can Bus system.

In last decade of 20th century, wireless sensor networks became effective and nowadays it is going on process. This system has several active nodes. A node may include any sensitive device, processor, calibrator, power supply, software and cryptos. Each node of network has sensor or device and the communication of them is made with route algorithms that continuously developed. These networks are named as WBSN for biosensor application. Micro electro mechanic (MEMS) is also affecting the development of WBSN technologies [53]. In such cases to define new area for sensor network development, some hybrid systems and different hierarchical routine protocols are needed to be improved [58- 60].

Wireless Sensor Biosensor Networks

In many applications, getting and monitoring information in wired way from sensors is not possible. Therefore, the values of these sensors with wireless perception monitoring methods are needed. When wired sensor networks compared with wireless sensor networks, WBSN and WSN have good opportunities about security of these networks with using cryptos, limitations, robust systems e.t.c. [59], [61].

On the other hand, data transmission, communication costs and low power consumption are remarkable aspects of wireless sensor networks. Some of the several nodes includes functioned nodes and information systems are evaluating in the same system at the same time with the development of detection (sensing) technology and sensors in many applications in many areas. Especially data coming from multiple points and small functioned nodes increases the accuracy to be perceived. So, complex networks system has sustainable configuration.

Therefore wireless communication has been a hot topic nowadays. WSN (wireless sensor network), the name of this book, the WBSN (Wireless Biosensor Networks) is a wireless network system which continues its development since the 1990's. These network systems have widespread application areas such as military, pollution observation, natural disaster, healthcare etc. Medical imaging, medicine releasing, remote sensing, remote measuring, mine detection, wild life observations technologies have been developed which requires WBSN.

The network is in communication with each other consists of a large number of nodes as shown in Figure 17. This network has a wide coverage area and in tolerating errors but sometimes having limited computational and memory capabilities as depending on the topology of sensor networks and communication overlapping may prevent usage of this system.

A wireless network grouped the nodes in clustering and some file algorithms. Some clusters and trees include some sub clusters. It ensures the better communication performance in getting and processing datas that comes from biosensor network. This clustering system works on a base. Each cluster has a head named gateway and includes maximum 5 grouped levels. Gateway gives performance to reach to whole sensor in own cluster. These clusters includes sub cluster in a tree structure. Some route algorithms restricts the number of sub groups. Each cluster has a main point named as gateway. Whole system that consist mainly of gateway is a WSN.

In order to operate and organize the system an interface runs. This interface depend on operation protocols that chosen. Clustering systems is built as some models that given in

literature work reach system. The communication protocol are a software and communicates not only cluster via gateway but also to the sensor or device. The relaying and sensing is carried on sensor nodes [62],[63].

Wider-open systems can be found using these systems with classical internet, satellites and other networks. Sensors can communicate with each other each other using software. According to certain criterions but any nodes don't have any information in other nodes. This is the principle of any network. The wireless biosensor network provides access to the information easily anytime, anywhere [61].

A transceiver device and an actuator/device that gives or performs control commands are also available together with the sensors in network in these nodes for structuring of perception. It can be said that these nodes are physically in the same structures. The data stream and processes in this system is usually carried out by a process called. If these datas are analyzed by using different criteria and calculation algorithms, they will be transmitted to a central system from this base. All of these processes are handled by a network protocol and hardware [64]. The system can be built is a WBSN software protocol which has a high accuracy and reproducibility. Required software and communication protocols should be installed for the operation of the network system. The main currency protocols achieve very high speed incoming and outgoing data traffic. Protocols can be separated Data-centric protocols, Hierarchical Protocols, Locationbased Protocols. [65].

Particularly, at all of WSN Technologies, the routing protocols are developed in fast way. Some articles proposed these protocols. The routing protocols designed for WSN/WBSN can be classified based on path selection, as proactive, reactive, and hybrid and so on. These type of developing routines can be found in literature detailed and can be seen state of art [66].

In order to perform sensor network application can be used wireless adhoc networking. An ad-hoc is a network and it works as local area network (LAN). This system supports the devices, sensor connect as adhoc query. The knowledge signals is relayed from each node to other node. An adhoc network can organize this message traffics without any router. Adhoc networking is well known procedure not only sensors and devices but also development of data transmission and electronical application methods is carrying out the ad-hoc network routing protocols in WBSN systems.

But this technic cannot also effort some applications [56], [53]. Otherwise it is also partly old technic which includes much more nodes that may cause to pass other networking systems [67], [55] [68], [69].

So, entire network system receives the data, processes them, and also analyses and transmits them. These processes are calibration, linearization of nonlinear data, etc. Some of the nodes are equipped only with a functionality of continuing these processes, and the others can also provide energy to the system. In this way, an intelligent system can be achieved and operated at a great extent. There can be some nodes which are not operating while the other components of the system keep operating [69].

The system shown in Fig.17 defines the overall flow of WBSN. Fig 17 is made of transmitter and receiver. The transmitter consists of pulse generator, A/D converter, amplifier, PN spreading, modulator and radio transceiver [57], [64].

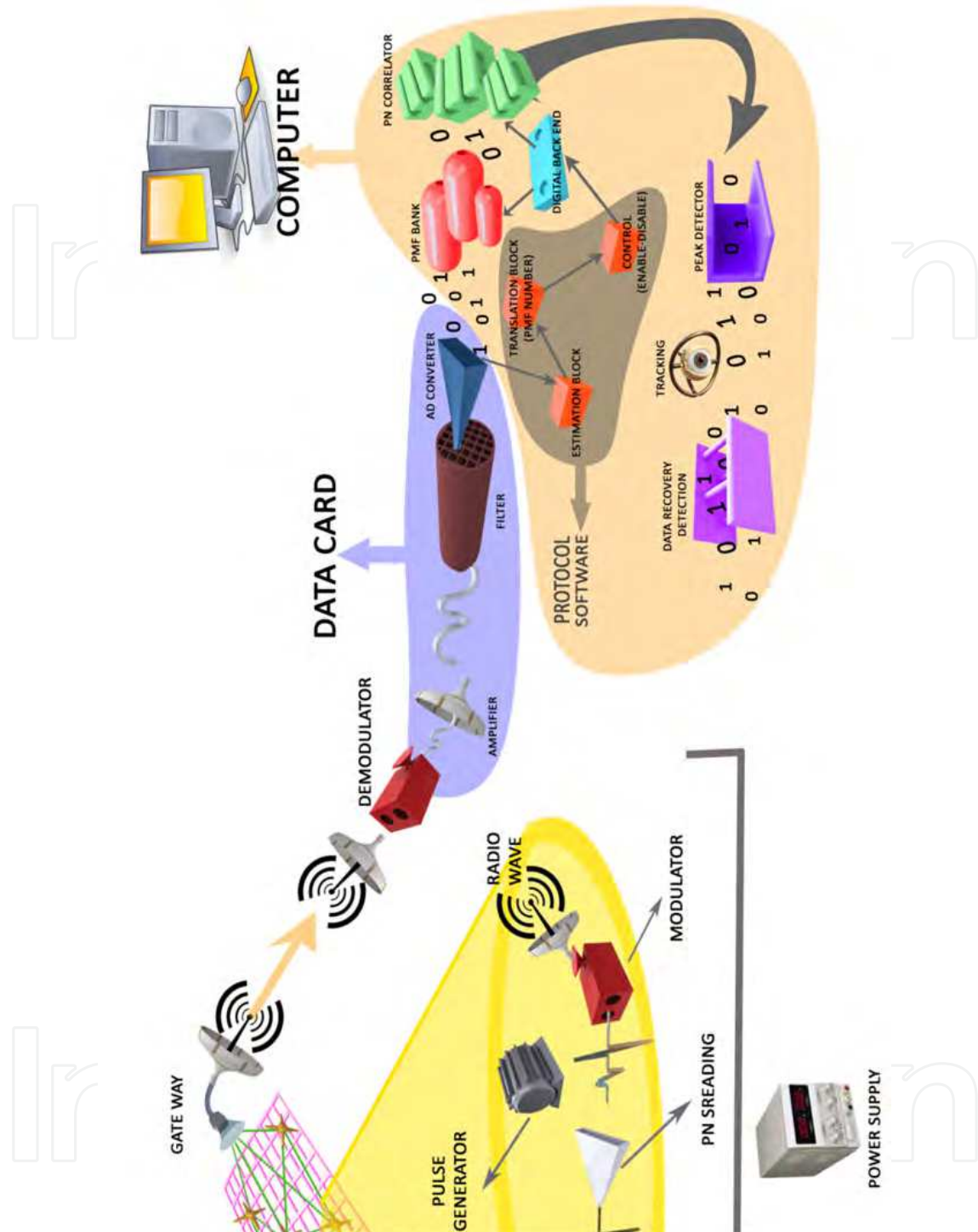

Fig. 17.

Data signal comes from a biosensor. Data is amplified and converted into digital by A/D converter. It is spread over a bandwidth by using PN Spreading and modulated by the modulator block. Modulated signal is then transmitted through the gateway by using Radio transceiver. Gateway in transmitter side takes all signals from all connected nodes and sends the signal to the gateway of the receiver. Receiver amplifies the signal, demodulates, filters and converts into analog by using A/D converter. Analog signal is placed to PMF

bank. Digital backend operates both PMF bank and PN Correlator. The digital backend operator is fully controlled by Protocol software, which contains estimation block, translation block and Control block (enable/disable). As a result, data is processed by using data detection, tracking and data recovery detection. In this flow, computer obtains the signal blocks from sampling frequency block and signal tracking is done. Since signal location in PMF varies with time and this dynamic change is traced by Tracking. Therefore, stable data detection becomes possible.

Also, Computer takes the data from PMF Bank. Estimation block analyzes where each block is. Afterwards, data is clustered and configured in accordance with PMF Number. If the data is used, control block enables the signal. If not, it disables the signal. This control is managed by the software.

Security of Wbsn

Security is one of the most important issues for WBSN systems since the application areas of these systems are highly sensitive. For example, any intrusion to a system in military or automotive industry can be directly related to life safety. Security of the system is as much important as its sustainability. Security of WSN/WBSN systems can be improved using more powerful protocols and crypto. So, a variety of forms are going to be exhibited in the design and adaptation of networks. These requirements are going to provide forming of architectural designs.

For the security of data and network; using new operational algorithms for nodes without external influences and threats, confidentiality of data, providing long lasting network operations, gathering the data without delay, broadcast and multicast identification systems are the other fields which help to improve the security [70], [71].

The Radio Characteristics of Wbsn Communication Systems

Systems WBSN's data applications need communication rates from Kbps to Mbps. Average distance of sink/base station is between 10 and 30 m. The signal that comes from sensor in any node is transmit to the center of Adhoc system as WSN/WBSN. A node gets a decision and this knowledge does not depend on network main communication and structure. High speed of data transfer is required especially for image transmission in WSN/WBSNs.

Ethernet cards transfer data at 0.1 GHz (100 Mbit). Thus, a bit per 10 ns data pulse is achieved. Following can be explained about the available radio waves: AM (amplitude modulation) radio waves called as the carrier have 400 kHz frequency and transmit the data. Data is modulated as amplitude. Receiver filters the data with 400 kHz and converts the data from the amplitude of the wave which is known as demodulation. AM is not a good choice for modulation. Because noise is embedded into the carrier, and so the quality of the data obtained from demodulation is poor. Data can be transmitted to far distances, but the effect of noise is elevated.

Frequency modulation (FM) is another system that can carry data and transmit over a carrier wave with modulation in frequency and this frequency is constant but amplitude of the carrier changes. This is different to amplitude modulation method. FM baseband is between 88 and 108 MHz. Frequency of the carrier is varied into UHF (ultra high frequencies), VHF (very high frequencies) and UWB (ultra wide range) bands. Therefore, different frequency bands are occupied for various data migration.

GSM has the highest frequency band and data is carried as package-to-package in GHz level. In WSN, error-free data transmission is important. Depending on how far and how fast the data is transferred, wavelength must be selected. For example, a specific frequency range is assigned in satellite communication. Because, noises introduced in atmosphere levels must be separated. LNB (Low-noise block) can get very small signals. Reflected waves are focused on LNB and amplified to a sufficient level to process.

In addition to these, another network called "PHS" is commonly used in Japan mobile communication. PHS network provides good data communication in isolated locations such as underground and tunnels. Therefore, PHS is an option to use in WBSN under difficult environments. Available frequency bands for WBSN is from 6765 kHz up to 246 GHz [61].

3. Acknowledgement

Thanks to Enes ADANIR and Mehmet İŞCAN for nice pictures in our chapter and also thanks to Kadriye ATICI KIZILBEY, Nural PASTACI and Assoc. Prof. Afife Binnaz HAZAR YORUÇ for their support and help.

4. References

- [1] Sassolas A, Blum L.J, Leca-Bouvier B.D (2011) Immobilization Strategies to Develop Enzymatic Biosensors *Biotechnology Advances* 30(3): 489-571.
- [2] Nambiar S, Yeow J.T.W (2011) Conductive Polymer-Based Sensors for Biomedical Applications *Biosensors and Bioelectronics* 26: 1825-1832.
- [3] Thevenot DR, Toth K, Durst R.A, Wilson G.S (1999) Electrochemical Biosensors: Recommended Definitions and Classification, *Pure Appl. Chem.* 7: 2333-2348.
- [4] Sadana A. (2006) Binding and Dissociation Kinetics for Different Biosensor Applications Using Fractals, Pages 219-242.
- [5] Liu G, Lin Y (2005) Electrochemical Sensor for Organophosphate Pesticides and Nerve Agents Using Zirconia Nanoparticles as Selective Sorbents, *Anal. Chem.* 77: 5894-5901.
- [6] Dixon B.M., Lowry J. P., O'Neill R.D. (2002) Characterization in vitro and in vivo of the oxygen dependence of an enzyme/polymer biosensor for monitoring brain glucose *Journal of Neuroscience Methods* Volume 119, Issue 2 Pages 135 - 142
- [7] Arora P, Sindhu A, Dilbaghi N, Chaudhury A (2011) Biosensors as Innovative tools for the detection of food borne pathogens", *Biosensors and Bioelectronics* 28 (2011) 1-12.
- [8] Kuila T, Bose S, Khanra P, Mishra A.K, Kim N.H, Lee J.H (2011) Recent Advances in Graphene-Based Biosensors, *Biosensors and Bioelectronics* 26: 4637- 4648.
- [9] Kissinger P, Heineman W.R (1996) *Laboratory Techniques in Electroanalytical Chemistry*, Second Edition, Revised and Expanded (2 ed.). CRC Press, ISBN 0824794451.
- [10] Allen B.J, Faulkner L.R (2000) *Electrochemical Methods: Fundamentals and Applications* (2 ed.). Wiley. ISBN 0471043729.
- [11] Zoski, Cynthia G. (2007) *Handbook of Electrochemistry*, Elsevier Science. ISBN 0444519580.

- [12] Bard, Allen J.; Larry R. Faulkner (2000) *Electrochemical Methods: Fundamentals and Applications* (2 ed.). Wiley. ISBN 0471043729.
- [13] R.S Nicholson, Shain I (1964) *Theory of Stationary Electrode Polarography. Single Scan and Cyclic Methods Applied to Reversible, Irreversible, and Kinetic Systems* *Analytical Chemistry* 36(4): 706-723.
- [14] Heinze J (1984) *Cyclic Voltammetry Electrochemical Spectroscopy New Analytical Methods* *Angewandte Chemie International Edition in English* 23 11: 831-847.
- [15] Eggins B.R (2002) *Chemical Sensors and Biosensors*, John Wiley&Sons Ltd, England.
- [16] Gray L.G.S, Appleman B.R (2003) *Eis: Electrochemical Impedance Spectroscopy*, *Journal of Protective Coatings & Linings* 2: 66-74.
- [16] Du D, Chen S, Cai J, Zhang A (2007) *Immobilization of Acetylcholinesterase on Gold Nanoparticles Embedded in Sol-Gel Film for Amperometric Detection of Organophosphorous Insecticide*, *Biosens. Bioelectron.* 23: 130-134.
- [17] Biran I, Walt D.R (2004) *Optrode- Based Fiber Optic Biosensors (Bio-Optrode)*. In: Ligler F.S, Taitt C.A.R, editors. *Optical Biosensors Present and Future*. Elsevier, Amsterdam: ISBN:0-444-50974-7. pp 5-16.
- [18] Eggins B.R (2004) *Chemical Sensors and Biosensors*, West Sussex PO19 SSQ, England: ISBN 0 47 1 899 13 5 (cloth) 0 71 89914 3. pp. 51-52.
- [19] Marazuela M.D, Moreno- Bondi M.C (2002) *Fiber Optic Biosensors-an Overview*, *Anal. Bioanal. Chem.* 372: 664-682.
- [20] Canh T.M (1993) *Biosensors* Chapman&Hall an Masson Paris: ISBN 0 412 48190 1 pp. 126-129.
- [21] Aboul-Enein H.Y, Stefan R.I, Van Staden J.F, Zhang X.R, Garcia- Campana A.M, Baeyens W.R.G (2000) *Recent Developments and Applications of Chemiluminescence Sensors*, *Critical Rev. Anal. Chem.* 30(4): 271-289.
- [22] Gübitz G, Schmid M.G, Silviaeh H, Aboul-Enein H.Y (2001) *Chemiluminescence Flow-injection Immunoassays*, *Critical Reviews in Analytical Chemistry.* 31 2: 141-148.
- [23] Wang P, Liu Q (2011) *Biomedical Sensors and Measurement*, Newyork: Springer Zhejiang University Press, ISBN 978-3-642-19524-2.
- [24] Feng M, Han H, Zhang J, Tachikawa H (2008) *Electrochemical Sensors Based on Carbon Nanotubes*. In: Zhang X, Ju H, Wang J, editors. *Electrochemical Sensors, Biosensors and Their Biomedical Applications*. Elsevier Inc. pp. 462-463.
- [25] Ajayan PM (1999) *Nanotubes from Carbon*, *Chem. Inform.* 30 39: 1787-1799.
- [26] Rivas G.A, Rubianes M.D, Rodríguez M.C, Ferreyra N.F, Luque G.L, Pedano M.L, Miscoria S.A (2007) *Carbon Nanotubes for Electrochemical Biosensing*, *Concepción Parrado, Talanta.* 74: 291-307.
- [27] Iijima S (1991) *Helical Microtubules of Graphitic Carbon*, *Nature* 354, 56 p.
- [28] Ajayan P.M, Zhou O.Z (2001) *Applications of Carbon Nanotubes in Carbon Nanotubes*. In: G. Dresselhaus, Ph. Avouris (Eds.), Springer, Heidelberg, pp. 391-425.
- [29] Dresselhaus M.S, Lin Y.M, Rabin O, Jorio A, Souza Filho A.G, Pimenta M.A, Saito R, Ge G, Samsonidze G, Dresselhaus G (2003) *Nanowires and Nanotubes*, *Mater. Sci. Eng. C* 23: 129-140.
- [30] Kingston C.T, Simard B (2003) *Fabrication of Carbon Nanotubes*, *Anal. Lett.* 36 (15): 3119 - 3145.

- [31] Zhou O, Shimoda H, Gao B, Oh S, Fleming L, Yue G (2002) *Materials Science of Carbon Nanotubes: Fabrication, Integration, and Properties of Macroscopic Structures of Carbon Nanotubes*, *Acc. Chem. Res.* 35 (12): 1045-1053.
- [32] Balasubramanian K, Burghard M (2005) *Small* 1, 180 p.
- [33] Iura H.H, Ebbe sen T.W, Tanigaki K (1995) *Adv. Mater.* 7, 275 p.
- [34] Britto P.J, Santhanam K.S.V, Alonso V, Rubio A, Ajayan P.M (1999) *Carbon Nanotube Electrode for Oxidation of Dopamina*, *Adv. Mater.* 11, 11 p.
- [35] Joshi P.P, Merchant S.A, Wang Y, Schmidtke D.W (2005) *Amperometric Biosensors Based on Redox Polymer-Carbon Nanotube-Enzyme Composites*, *Anal. Chem.* 77 : 3183-3188.
- [36] Merkoci A (2006) *Carbon Nanotubes in Analytical Sciences*, *Microchim. Acta*, 152: 157-174.
- [37] Banks C.E, Crossley A, Salter C, Wilkins S.J, Compton R.G (2006) *Carbon Nanotubes Contain Metal Impurities Which Are Responsible for the 'Electrocatalysis' Seen at Some Nanotube-Modified Electrodes*, *Angew. Chem. Int. Ed.* 45, 2533 p.
- [38] Gooding J.J (2005) *Nanostructuring electrodes with carbon nanotubes: A review on electrochemistry and applications for sensing*, *Electrochim. Acta* 50: 3049-3060.
- [39] Katz E, Willner I (2004) *Biomolecule-Functionalized Carbon Nanotubes: Applications in Nanobioelectronics*, *Chem. Phys. Chem.* 5: 1084-1104.
- [40] Merkoci A, Pumera M, Llopis X, P´erez B, del Valle M, Alegret S (2005) *New Materials for Electrochemical Sensing VI Carbon Nanotubes*, *Trends Anal. Chem.* 24: 826-838.
- [41] Wang J (2005) *Electroanalysis* 17, 7 p.
- [42] Valc´arcel M, Simonet B.M, C´ardenas S, Su´arez B (2005) *Present and Future Applications of Carbon Nanotubes to Analytical Science*, *Anal. Bioanal. Chem.* 382: 1783-1790.
- [43] Jiang M, Lin Y (2006) *Encyclopedia of Sensors in: Grimes G.A, editor. American Scientific Publisher* 6, 2: 25-51. ISBN 1-58883-058.
- [44] Lu L.M, Zhang X.B, Shen G.L, Yu R.Q (2012) *Seed-Mediated Synthesis of Copper Nanoparticles on Carbon Nanotubes and Their Application in Nonenzymatic Glucose Biosensors*, *Analytica Chimica Acta* 715: 99-104.
- [45] Wang Y, Du J, Li Y, Shan D, Zhou X, Xue Z, Lu X (2012) *A Amperometric Biosensor for Hydrogen Peroxide by Adsorption of Horseradish Peroxidase onto Single-Walled Carbon Nanotubes*, *Colloids and Surfaces B: Biointerfaces* 90: 62- 67.
- [46] Hoshino T, Sekiguchi S, Muguruma H (2012) *Amperometric Biosensor Based on Multilayer Containing Carbon Nanotube, Plasma-Polymerized Film, Electron Transfer Mediator Phenothiazine, Andglucose Dehydrogenase*, *Bioelectrochemistry* 84: 1-5.
- [47] Narang J, Chauhan N, Jain P, Pundir C.S (2012) *Silver Nanoparticles/Multiwalled Carbon Nanotube/Polyaniline Film For Amperometric Glutathione Biosensor*, *International Journal of Biological Macromolecules* 3: 672-678.
- [48] Lin Y, Lu F, Tu Y, Ren Z (2004) *Glucose Biosensors Based on Carbon Nanotube Nanoelectrode Ensembles*, *Nano Letters* 4(2):191-195.
- [49] Li J, Wang Y.B, Qiu J.D, Sun D.C, Xia X.H (2005) *Biocomposites of Covalently Linked Glucose Oxidase on Carbon Nanotubes for Glucose Biosensor*, *Anal. Bioanal. Chem.* 383: 918-922.

- [50] Antiochia R, Lavagnini I, Magno F (2004) Amperometric Mediated Carbon Nanotube Paste Biosensor for Fructose Determination, *Anal. Lett.* 37: 1657-1669.
- [51] Li G, Liao J.M, Hu G.Q, Ma N.Z, Wu P.J (2005) Study of Carbon Nanotube Modified Biosensor Formonitoring Total Cholesterol in Blood, *Biosen. Bioelectron.* 20: 2140-2144.
- [52] Rivas G.A, Pedano M.L (2006) Electrochemical DNA Biosensors, in: Craig Encyclopedia of Sensors, American Scientific Publishers, ISBN 1-58883-059-4 3: 45-91.
- [53] Ye Y, Ju H (2005) Rapid Detection of ssDNA and RNA Using Multi-Walled Carbon Nanotubes Modified Screen-Printed Carbon Electrode, *Biosens. Bioelectron.* 21: 735-741.
- [54] Cai H, Cao X, Jiang Y, He P, Fang Y (2003) Carbon Nanotube- Enhanced Electrochemical DNA Biosensor for DNA Hybridization Detection, *Anal. Bioanal. Chem.* 375: 287-293.
- [55] Cai H, Xu Y, He P, Fang Y (2003) Indicator Free DNA Hybridization Detection by Impedance Measurement Based on the DNA-Doped Conducting Polymer Film Formed on the Carbon Nanotube Modified Electrode *Electroanalysis* 9, 15: 1864-1870.
- [56] Bergveld P (1996) The Future of Biosensors. *Sensors and Actuators A: Physical*: ISSN 0924-4247. 56: 65-73.
- [57] Lambrianou A, Demin S, Hall E.A (2008) Protein Engineering and Electrochemical Biosensors, *Adv. Biochem. Eng. Biotechnol.* 109: 65-96.
- [58] Brett C.M. A, Brett A.M.O (1994) *Electrochemistry Principles, Methods, And Applications*, Oxford University Press, Great Britain.
- [59] Wang P, Liu Q (2011) *Biomedical Sensors and Measurement*, Zhejiang University - Verlag Springer Press, 4.7: 183 - 195.
- [60] Sichertiu M.L (2004) Cross Layer Scheduling for Power Efficiency in Wireless Sensor Networks.
- [61] Akyildiz I.F, Su W, Senkorasubramanioam Y, Cayirci E (2002) Wireless Sensor Networks a Survey, *Computer Networks.* 28(4): 383-422.
- [62] Miao L, Djouani K, Kurien A, Noel G (2012) Network Coding and Competitive Approach for Gradient Based Routing in Wireless Sensor Networks., *Adhoc Networks.*, <http://dx.doi.org/10.1016/j.bbr.2011.03.031>
- [63] Naik R, Singh J, Le H.P (2010) Intelligent Communication Module for Wireless Biosensor Networks. In: Pier Andrea Serra, editor. *Biosensors. InTech.* pp. 225-240.
- [64] Manjeshwar A, Agarwal I D.P (2001) Teen: a Routing Protocol for Enhanced Efficiency in Wireless Sensor Networks. *Proc. 15th Int. Parallel and Distributed Processing Symp.* pp. 2009-2015.
- [65] Heinzelman W, Chandrakasan A, Balakrishnan H (2000) Energy-Efficient Communication Protocol for Wireless Microsensor Networks. *Proceedings of the Hawaii Conference on System Sciences* pp. 1-10.
- [66] Schurgers C, Srivastava M.B (2001) Energy Efficient Routing in Wireless Sensor Networks. *Proc. Communications for Network-Centric Operations: Creating the Information Force. IEEE Military Communications Conf. MILCOM 2001.* 1: 357-361.

- [67] Cheng H, Yang G, Hu S (2008) NHRPA: a Novel Algorithm for Hierarchical Routing Protocol Networks Wireless Sensor, *The Journal of China Universities of Posts and Telecommunications* 15(3): 75-81.
- [68] Prasad N.R, Alam M (2006) Security Framework for Wireless Sensor Networks. *Wireless Personal Communications*, 37: 455-469.
- [69] Xu Y, Heidemann J, Estrin D (2001) Geography-Informed Energy Conservation for Ad Hoc Routing, *Proceedings of the 7th Annual International Conference on Mobile Computing and Networking, MobiCom '01.*, 70-84.
- [67] Akkaya K, Younis M (2005) A Survey on Routing Protocols for Wireless Sensor Networks, *Ad Hoc Networks*. 3, 325-349.
- [68] Misra S, Dias Thomasinos P (2010) A Simple, Least-Time and Energy-Efficient Routing protocol with One-Level Data Aggregation for Wireless Sensor Networks, *Journal of Systems and Software* 83(5): 852-860.
- [69] Perkins C, Das S.R, Royer E.M (2000) Performance Comparison of Two On-demand Routing Protocols for Ad Hoc Networks. *IEEE Infocom 2000*, 3 - 12.
- [70] Intanagonwiwat C, Govindan R, Estrin D, Heidemann J, Silva F (2003) Directed Diffusion for Wireless Sensor Networking, *IEEE/ACM Trans. Network*. 11(1), 2-16.
- [71] Karl H, Willig A (2003) A Short Survey of Wireless Sensor Networks, *Technical University Berlin, Telecommunication Networks Group*.

IntechOpen

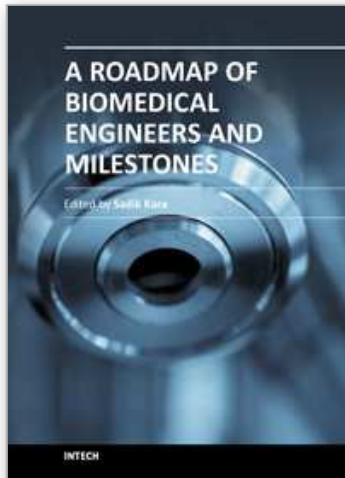

A Roadmap of Biomedical Engineers and Milestones

Edited by Prof. Sadik Kara

ISBN 978-953-51-0609-8

Hard cover, 230 pages

Publisher InTech

Published online 05, June, 2012

Published in print edition June, 2012

This book is devoted to different sides of Biomedical Engineering and its applications in science and Industry. The covered topics include the Patient safety in medical technology management, Biomedical Optics and Lasers, Biomaterials, Rehabilitat, Ion Technologies, Therapeutic Lasers & Skin Welding Applications, Biomedical Instrument Aopplcation and Biosensor and their principles.

How to reference

In order to correctly reference this scholarly work, feel free to copy and paste the following:

Ahmet Koyun, Esmâ Ahlatcıođlu and Yeliz Koca İpek (2012). Biosensors and Their Principles, A Roadmap of Biomedical Engineers and Milestones, Prof. Sadik Kara (Ed.), ISBN: 978-953-51-0609-8, InTech, Available from: <http://www.intechopen.com/books/a-roadmap-of-biomedical-engineers-and-milestones/biosensor-and-their-principles>

INTECH
open science | open minds

InTech Europe

University Campus STeP Ri
Slavka Krautzeka 83/A
51000 Rijeka, Croatia
Phone: +385 (51) 770 447
Fax: +385 (51) 686 166
www.intechopen.com

InTech China

Unit 405, Office Block, Hotel Equatorial Shanghai
No.65, Yan An Road (West), Shanghai, 200040, China
中国上海市延安西路65号上海国际贵都大饭店办公楼405单元
Phone: +86-21-62489820
Fax: +86-21-62489821

© 2012 The Author(s). Licensee IntechOpen. This is an open access article distributed under the terms of the [Creative Commons Attribution 3.0 License](#), which permits unrestricted use, distribution, and reproduction in any medium, provided the original work is properly cited.

IntechOpen

IntechOpen