

We are IntechOpen, the world's leading publisher of Open Access books Built by scientists, for scientists

4,800

Open access books available

122,000

International authors and editors

135M

Downloads

Our authors are among the

154

Countries delivered to

TOP 1%

most cited scientists

12.2%

Contributors from top 500 universities



WEB OF SCIENCE™

Selection of our books indexed in the Book Citation Index
in Web of Science™ Core Collection (BKCI)

Interested in publishing with us?
Contact book.department@intechopen.com

Numbers displayed above are based on latest data collected.
For more information visit www.intechopen.com



3D Woven Fabrics

Pelin Gurkan Unal

*Namik Kemal University Department of Textile Engineering
Turkey*

1. Introduction

Composite material, also called composite, a solid material that results when two or more different substances, each with its own characteristics, are combined to create a new substance whose properties are superior to those of the original components in a specific application (Encyclopædia Britannica, 2011). Because the objective in manufacturing component is to produce a stiff and a strong material with a low density, these materials have found place in many application fields such as land transportation, marine, construction, aerospace and medical. There are two constituents in a composite material which are the reinforcement and matrix phases. From the matrix point of view, composites can be divided into three main categories; polymer, metal and ceramic matrix composites (Zhang, 2003). Based on the reinforcement mechanism, composites can be separated as particle reinforced (large particle, dispersion strengthened), fibre reinforced (continuous (aligned), and short fibres (aligned or random)) and structural composites (laminates, sandwich). Fibre reinforced composites have been first introduced in exterior parts of Corvette in 1953. Today, fibre reinforced composites are used in many application fields.

Textile structural composites usually consist of stacked layers known as 2D laminates, exhibit better in-plane strength and stiffness properties compared to those of metals and ceramics (Bilisik, 2010, 2011; Mohamed&Bogdanovich, 2009). However, the application of 2D laminates in some critical structures in aircraft and automobiles has also been restricted by their inferior impact damage resistance and low through thickness mechanical properties when compared against the traditional aerospace and automotive materials such as aluminium alloys and steel (Mouritz et al., 1999). These structures have low out-of plane properties because of the lack of third direction reinforcements which will result in low delamination resistances (Chou, 1992). In order to improve interlaminar properties of the 2D laminates, three dimensional (3D) textile preforms have been developed by using different manufacturing techniques like weaving, knitting, braiding, stitching, and non-woven manufacturing. Among these manufacturing techniques, sewing and 3D weaving are the promising technologies which address the shortcomings of the stack-reinforced composites (Padaki et al., 2010). Since manufacturing technology has a direct effect on the fibre orientation and fibre volume fraction of the preform, the properties of the end product will vary depending on the production and end-use requirements (Peters, 1998).

Although 3D woven preforms have been used for approximately forty years in different application fields, there is not a common understanding and definition of these fabrics

which make them difficult to comprehend. Therefore, this chapter attempts to make a detailed overview of 3D woven fabrics, basic structure of 3D woven fabrics, definitions and classifications of 3D woven fabrics in comparison with 2D woven fabrics.

2. Definition, classification and weave structures of 3D woven fabrics

2.1 Definition of 3D woven fabrics

A basic common definition of 3D fabric is that these types of fabrics have a third dimension in the thickness layer. In 3D-fabric structures, the thickness or Z-direction dimension is considerable relative to X and Y dimensions. Fibres or yarns are intertwined, interlaced or intermeshed in the X (longitudinal), Y (cross), and Z (vertical) directions (Badawi, 2007).

3D fabrics can also be defined as “a single-fabric system, the constituent yarns of which are supposedly disposed in a three mutually perpendicular plane relationship” (Behera&Mishra, 2008). According to Chen, structures that have substantial dimension in the thickness direction formed by layers of fabrics or yarns, generally termed as the three-dimensional (3D) fabrics (Chen, 2011). Although all textiles have a 3D internal structure, macroscopically most can be regarded as thin 2D sheets. By 3D fabrics, (1) thick multilayer fabrics in a simple regular form or (2) made in more complicated 3D shapes, (3) hollow multilayer fabrics containing voids and (4) thin 3D shells in complex shapes are meant (Hearle&Chen, 2009). Khokar defined 3D woven fabrics as a fabric, the constituent yarns of which are supposed to be disposed in a three-mutually-perpendicular-planes relationship (Khokar, 2001).

2.2 Classification of 3D woven fabrics

When the classification of 3D woven fabrics are examined, it is observed that there are several classifications based on the shedding mechanisms, weaving process, geometries and configurations, interlacements and fibre axis according to the different researches (Khokar,1996 as cited in Soden&Hill, 1998; Chen, 2010; Soden&Hill, 1998; Bilisik, 2011).

Khokar classified the 3D fabrics as follows (Khokar, 1996 as cited in Soden&Hill, 1998);

1. The conventional 2D weaving process designed to interlace two orthogonal sets of threads (warp and weft). This produces *an interlaced 2D fabric* on a 2D weaving device.
2. The conventional 2D weaving process designed to interlace two orthogonal sets of yarns (warp and weft) with an additional set of yarns functioning as binder warps or interlacer yarns in the through-the-thickness or Z direction. This is referred to as multilayer weaving and produces *an interlaced 3D fabric* constituting two sets of yarns on a 2D weaving device.
3. The conventional 2D weaving process using three sets of yarns (ground warp, pile warp and pile weft) to produce pile fabrics, known as *2.5D fabrics*.
4. The conventional 2D weaving process using three sets of yarns to produce a non-interlaced fabric with yarns in the warp, weft and through-the-thickness directions. This produces *a non-interlaced 3D fabric* with three sets of yarns on a 2D weaving device.
5. The 3D weaving process designed to interlace three orthogonal sets of yarns. The weaving shed operates both row-wise and column-wise. This produces *a fully interlaced 3D fabric* where all three sets of orthogonal yarns interlace on a specifically designed 3D weaving machine.

6. A non-woven, non-interlaced 3D fabric forming process designed to connect three orthogonal sets of yarns together with no interlacing (weaving), interloping (knitting), or intertwining (braiding). The fabric is held together by a special binding process.

However Soden and Hill added a new category as 4A to Khokar's classification for the fabrics that could be placed between categories 4 and 5 where the conventional 2D weaving process uses three sets of yarns to produce *an interlaced 3D fabric* with yarns in the warp, weft and through-the-thickness directions (Soden&Hill, 1998).

Regardless of the types of machines used, weaving technology is capable of constructing 3D fabrics with many different geometrical shapes. Chen studied the configurations and geometries of the 3D woven fabrics and classified 3D woven fabrics into four different categories, as listed in Table 1 (Chen, 2007 as cited in Chen et al., 2011).

Structure	Architecture	Shape
Solid	Multilayer Orthogonal Angle Interlock	Compound structure, with regular or tapered geometry
Hollow	Multilayer	Uneven surfaces, even surfaces, and tunnels on different level in multi-directions
Shell	Single layer Multilayer	Spherical shells and open box shells
Nodal	Multilayer Orthogonal Angle Interlock	Tubular nodes and solid nodes

Table 1. 3D textile structures and weave architectures (Chen, 2011).

2.3 Weave structures and properties

In 3D woven fabrics, generally multilayer, angle interlock and orthogonal weave architectures are the most widely used weave structures. While multilayer and angle interlock weave structures can be produced with conventional 2D weaving machines especially with shuttle looms, orthogonal weave architecture needs a special designed 3D weaving machine to be produced. Orthogonal weave structures consist of three sets of yarns that are perpendicular to each other (X, Y and Z coordinates). In this particular 3D woven fabric formation process, Z yarns interconnect all individual warp- and fill-directional yarns and thus solidify the fabric (Bogdanovich, 2007). Mechanical and structural properties of the composites having orthogonal weave architectures with various binding weaves and different numbers of layers were investigated (Chen&Zanini, 1997 as cited in Behera&Mishra, 2008). The results of the investigation are as follows:

- Since straight yarns exist in the orthogonal structures, tensile stiffness and strength properties of these structures are well regardless of type of binding weave. However, tensile stiffness and strength values of these weave structures are directly proportional with the number of layers.

- Number of layers and binding weaves do not affect the breaking elongation of the orthogonal structures. This property is mostly dependent on the elongation properties of the yarns used.
- The shear rigidity and shearing hysteresis increases when more layers are involved.
- Tighter binding weaves and more layers of the orthogonal structure will produce higher bending stiffness and bending hysteresis.

Multilayer weave structures consist of multiple layers each of which have its own sets of warp and weft yarns. The connection of the layers is done by self-stitching (existing yarns) or central stitching (external sets of yarns). In angle interlock weave structures; there are at least two sets of yarns such as warp and weft. In some cases, in order to increase fibre volume fraction and in-plane strength, stuffer yarns can be added. Angle interlock weaves are divided into two groups; through thickness angle interlock and layer to layer angle interlock weaves. In through thickness angle interlock weaves, warp yarn travels from one surface of the 3D fabric to the other holding all the layers together, whereas in layer to layer angle interlock weaves warp yarn travels from one layer to the adjacent layer and back. A set of warp weaves together hold all the layers of the weave structure. Mechanical properties of 3D angle interlock woven composites are not as good as the mechanical properties of corresponding laminated composites. However, composites having angle interlock woven structure have advantages of enhanced delamination resistance, impact/fracture resistance, damage tolerance and dimensional stability (Naik et al., 2002). Higher through-the-thickness elastic and strength properties can be achieved by using 3D orthogonal interlock woven composites (Naik et al., 2001).

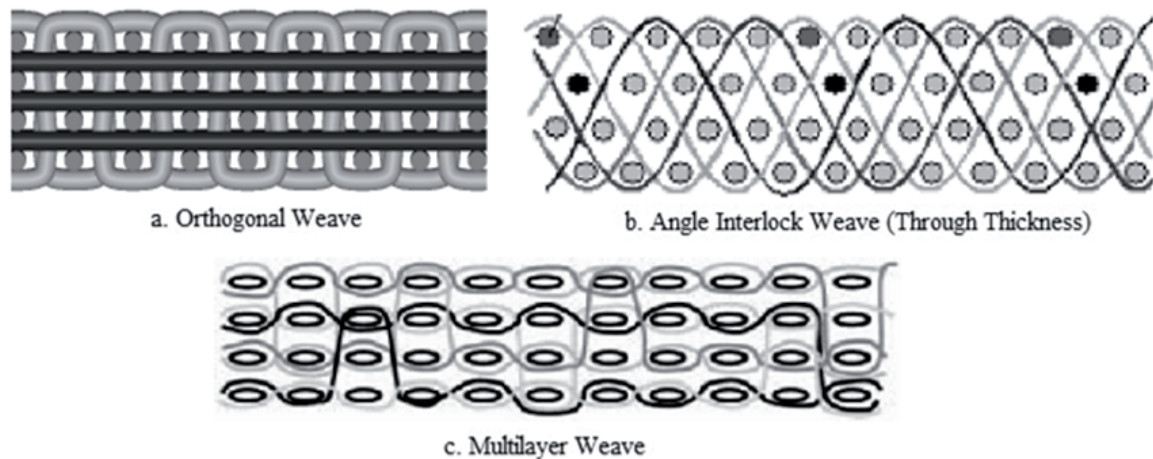

Fig. 1. Weave structures (Stig, 2009; Badawi, 2007; Chen, 2011).

Composites having different weave architectures will have different mechanical properties as well as structural stability. Chen et al investigated the mechanical and structural properties of the composites produced from 3D woven preforms having warp self-stitched multilayer weave and angle interlock weave (Chen et al., 1999). The results of the investigation are as follows:

- Increasing number of layers in multilayer weave structures results in a stronger structure. As the multilayer fabrics are warp self-stitched, the strength increase in weft direction is more significant than in the warp direction.

- The structural stability of multilayer structures increases when more layers are involved.
- For multilayer structures, the effect of weave combination is little on strength properties whereas it plays a significant role on structural stability.
- The increase in stitch density in multi-layer structures will generally reduce the strength of the structures, but its effect on the structural stability is not clear. The latter may be related to the distribution of the stitches and also to the weaving conditions.
- The number of layers of weft threads in angle-interlock structures mainly increases the tensile strength in the weft direction because of the construction.
- Angle-interlock structures permit more elongation in the warp direction than in the weft.
- The increase in the number of layers in angle-interlock structures makes the structures more difficult to bend; this is more significantly so in the weft direction than in the warp direction. However, the increase in the number of layers showed little influence on the shear rigidity.

3. Weaving

Weaving is an ancient tradition which dates back over seven millenniums. In traditional weaving, there are two sets of yarns, perpendicular to each other, interlace to form a woven fabric. While one set of the yarns that run lengthwise along the weaving machine direction are called warp, the other set of the yarns that run transversely from one side to the other side of the machine are called weft (a.k.a. filling).

There are three basic motions in order to produce a fabric by ensuring the interlacing between warp and weft yarns. These three essential motions are; shedding, weft insertion and beat-up. For the continuation of weaving process, warp yarns have to be let-off and the produced fabric has to be taken-up. These necessary two motions are auxiliary movements that are warp let-off and fabric take-up.

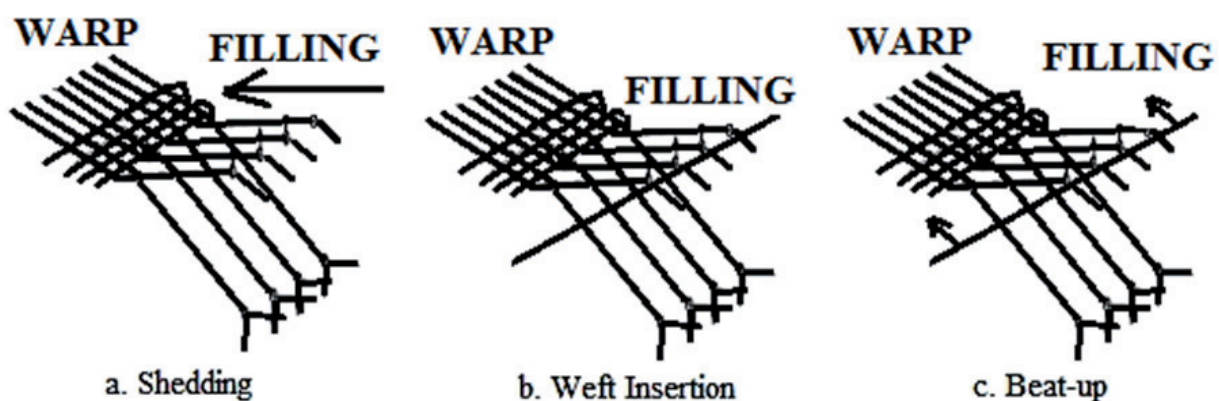

Fig. 2. Basic motions on weaving machine (Lord&Mohamed, 1982).

In order to get different weave structures in traditional weaving, the movement of the warp yarns have to be controlled and changed before each weft insertion. To perform warp yarns movement on a loom, warps that follow the same interlacing pattern have to be grouped with the same frame called harness. In each harness, there are heddles that have an eye in the middle in which the warp yarns pass through. By lifting the harness up or down, the

groups of warp yarns will move either upwards or downwards. Based on the pattern, there must be different harnesses for each group of warp yarns. In the case where each warp weaves a different pattern, a harness cord is provided for each heddle. There are four different shedding mechanisms to manipulate warp yarns; crank, cam, dobby and jacquard. Crank, cam or dobby mechanisms work together with harnesses. On the other hand in jacquard mechanism there are harness cords for each warp yarn, no harnesses. Thus patterning capability of jacquard mechanism is the highest among shedding mechanisms. By altering shedding motion, various weave structures such as plain, twill and satin can be produced.

When the shedding is opened based on the patterning, weft insertion takes place. Considering the weft insertion system of the weaving machine, weft insertion can be performed in different ways. In single-phase weaving machines, the weft yarn is carried from one side of the machine to the other side transversely by shuttle, projectile, rapier or jet systems. After the weft insertion, the reed beats up the last inserted weft and the produced fabric is taken up. For the next cycle, warp yarns have to be let off in order to open a shed. This cycle of operations are continued repeatedly to obtain the woven fabric in a sequence. This weaving process is called 2D weaving. Even this fabric production process is two dimensional (warp yarns are moved through fabric thickness and weft yarn is inserted at the open shed, consequently two orthogonal sets of yarns are interlaced), it is also possible to weave 3D woven fabrics known as multilayer structures. However, producing 3D woven fabrics with conventional weaving (2D weaving) does not mean that the process can be named 3D weaving. Because, the arrangement of the weaving motions unchanged whether a single warp sheet is used to produce sheet-like 2D fabrics or multiple warp sheets are used to produce multilayer 3D fabrics (Stig, 2009).

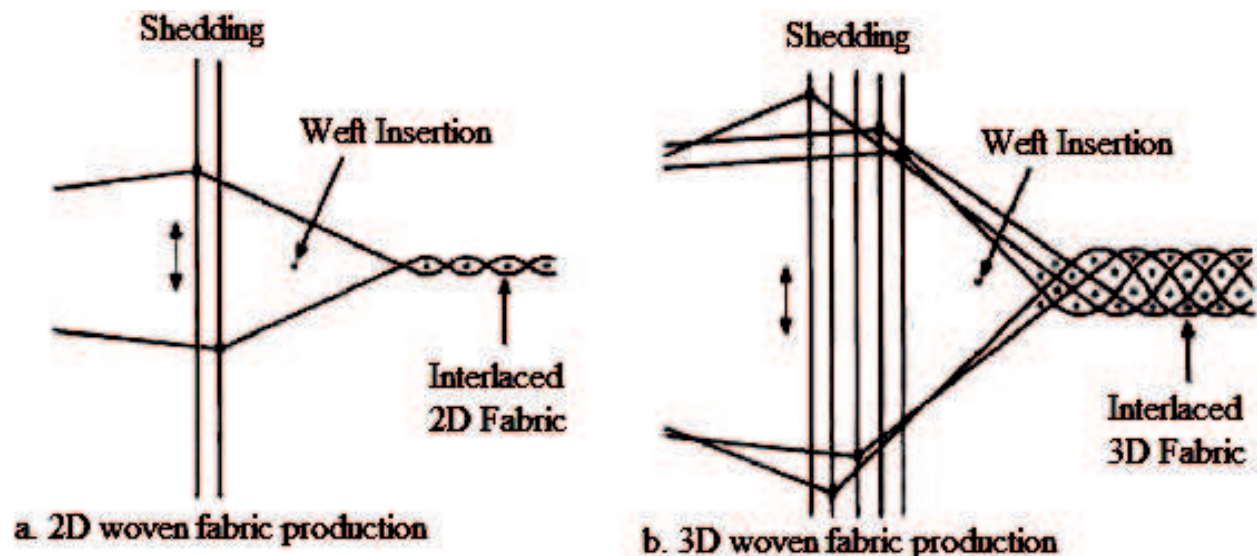

Fig. 3. Fabric production on conventional weaving machine (Khokar, 2001).

As previously mentioned, multilayer and angle interlock weave structures can be produced with 2D weaving. Unfortunately, composites made of 3D woven fabrics produced with 2D weaving have low in-plane stiffness and strength properties due to high crimp levels (Bogdanovich, 2007; Mohamed&Bogdanovich, 2009). A 3D woven fabric produced with 2D weaving is costly because only one weft insertion can take place during one cycle of

weaving machine. Furthermore increasing the thickness of 3D woven fabrics while producing them with 2D weaving makes the costs more (Bogdanovich, 2007). Therefore, a new method of 3D woven fabric has been required and developed that is called 3D weaving. However, there is not only one method of 3D weaving. There are different methods of 3D weaving techniques according to the produced structure (angle interlock, orthogonal or fully interlaced 3D woven structures) and orientation of the yarn sets (uniaxial, multiaxial).

4. 3D woven fabric production

3D woven fabrics can be manufactured both with 2D and 3D weaving. The produced 3D fabrics are different from the properties point of view due to the differences in weaving methods. With 2D weaving, pleated or plissé fabric, terry fabrics, velvet fabrics and multilayer woven fabrics can be manufactured. Orthogonal 3D weave structures, fully interlaced 3D weave structures can be manufactured only by using special designed 3D weaving machines. In this section, manufacturing methods of different 3D woven fabrics will be mentioned.

4.1 Production of 3D woven fabrics with 2D weaving

In the case of 2D weaving, two sets of perpendicular yarns are interlaced, irrespective of whether it is woven as single- or multi-layer. Another set of yarns, known as pile or binder yarns, can be introduced in the direction of fabric thickness. Fabrics could be produced by 2D techniques, with different sets of warp yarns in the ways mentioned below (Gokarneshan & Alagirusamy; 2009):

1. By effective utilisation of warp and weft in single layer.
2. By the use of multi-layer warp and weft or multi-layer ground warp, binder warp and weft.
3. Conventional 2D process can also produce pile fabrics by utilising three sets of yarns, namely, single-layer ground warp, pile warp and weft.

4.1.1 Production of Plissé or pleated fabrics

Plissé or pleated material is a folded material, which can be achieved in different methods such as weaving, shrinking and finishing (Route, 2002);

- i. Woven plissé: Produced by an additional device on a power loom; two warp systems of different tension achieve drape. Folding can also be achieved by suitable bindings. In knit goods folds are created by stitching.
- ii. Shrunk plissé is produced by the use of synthetic fibres with different shrinking properties.
- iii. Finishing plissé: The material is laid in folds, which are thermally fixed in so-called pleating machines.

Plissé or pleated woven fabrics can be produced on weaving machines equipped with two warp beams in addition to a special pleated device or a variable beat up.

Pleated woven fabric is produced on weaving machines equipped with a special pleated device as follows:

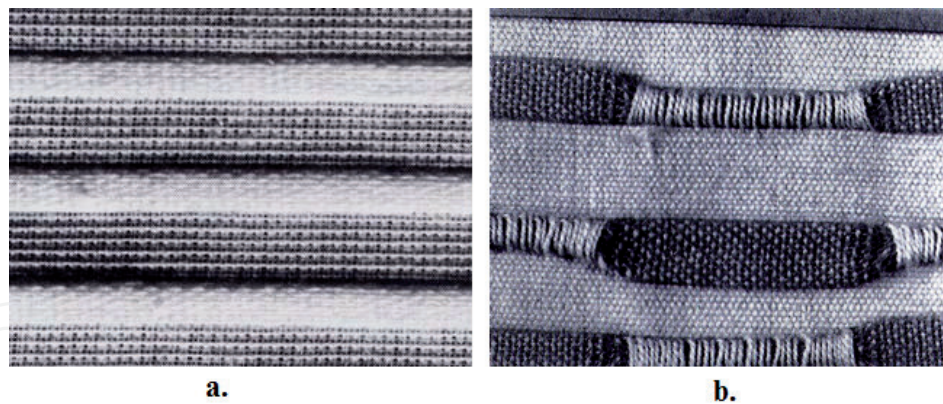

Fig. 4. The appearances of a) a smooth pleated fabric b) a tough pleated fabric (Kienbaum, 1996 as cited in Badawi, 2007).

In this method, at the beginning of pleat formation, both back rest and breast-beam take the most far on the right lying position as illustrated at point A in Figure 5. When the intended pleat length is reached, they are farther on the left (B). The distance between the two limit points A and B is determined by the pleat length. After the last weft insertion within the pleat length and with beginning of the next inter-fabric part, the pleated length is formed by returning back of the back rest and breast-beam into the starting position (A), at that moment the back rest pull the tight warp to the back position (A) (Badawi, 2007).

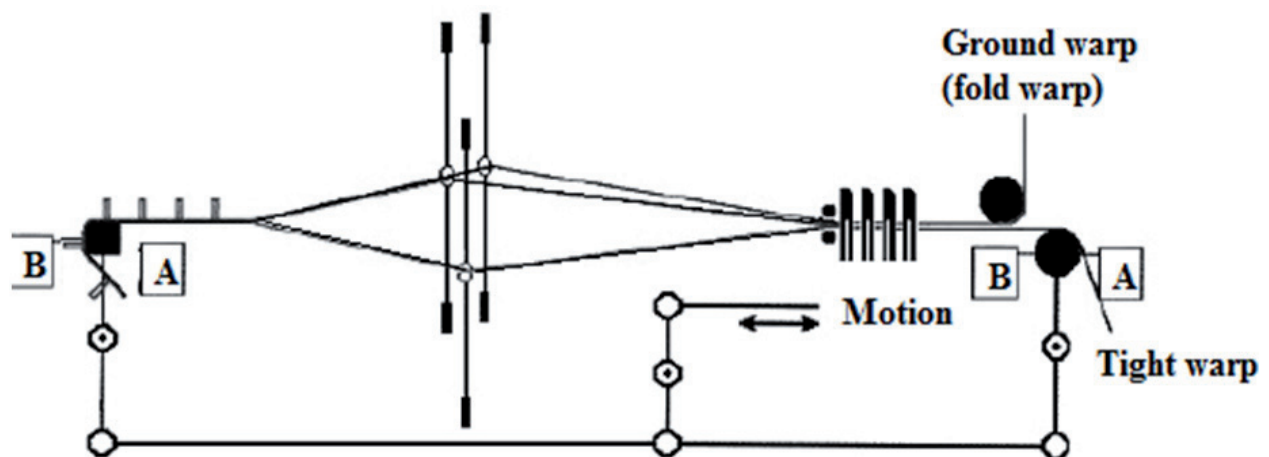

Fig. 5. Device for pleated fabrics weaving (Kienbaum, 1996 as cited in Badawi, 2007).

The coordination of pleated fabric and take-up mechanism are shown in Figure 6. The height of the formed pleat is equal to about half of the pleat length before the backward-movement of the tight warp yarns (Kienbaum, 1996 ; Hennig, 1968 as cited in Badawi, 2007).

Pleated woven fabric is also produced on weaving machines equipped with a variable sley beat up.

Manufacturing of pleated woven fabric on weaving machines equipped with a variable sley beat up can be briefly explained as follows;

The mechanism allows the beating-up point of the sley to be shifted by small but precise steps from the normal beating-up point. While the pleat is being woven, the fabric take-up remains idle so that the weft density is achieved by shifting the beating-up point of the sley.

With a weft density of 40 picks/cm, this means that the beating-up point needs to be shifted only 0.25 mm weft by weft. At the end of the woven pleat, which may be up to 20 mm long, the device must return to its normal beating-up position.

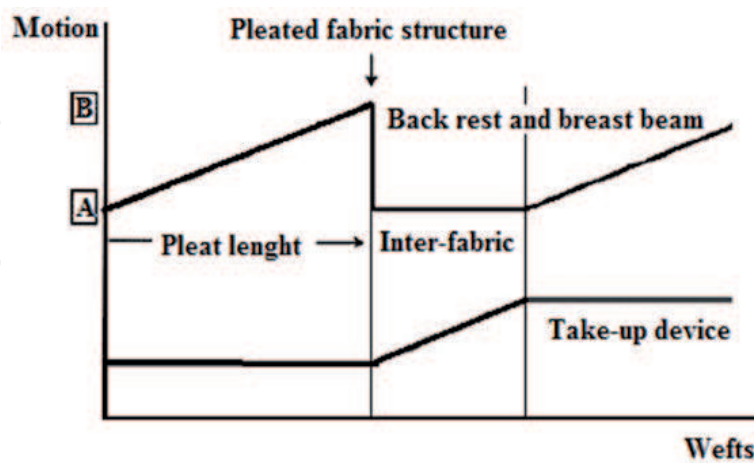

Fig. 6. Movement coordination of pleated fabric and take-up device (Kienbaum, 1996 as cited in Badawi, 2007).

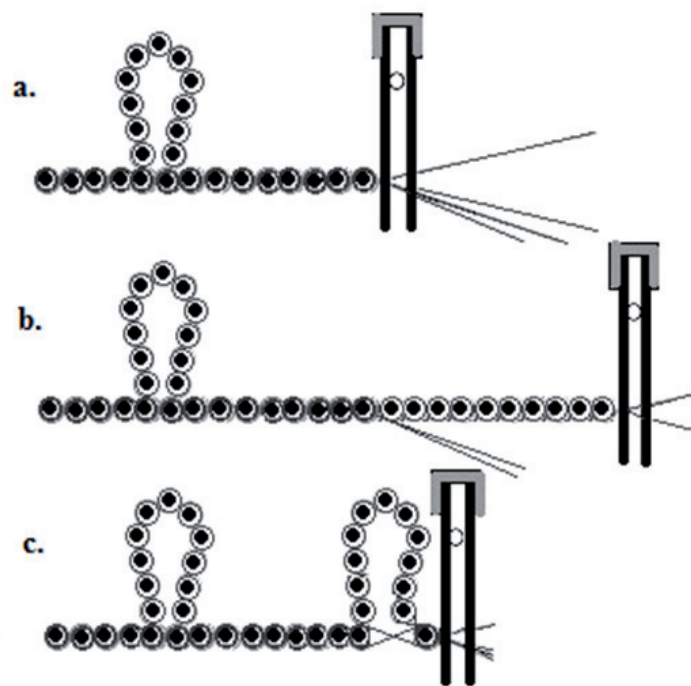

Fig. 7. Beat-up motion during pleat formation (redrawn from Marfurt, 1998).

Weaving a pleat uses only some of the warp threads which are wound onto a separate warp beam. The small proportion of warp threads in the pleat area is compensated for by a greater weft density. The remaining warp threads are left lying underneath the fabric while the pleat is being woven (a). The fabric is no longer taken off, and the sley stays back a given distance in each weft (b). Once the pleat has reached the desired length, all the warp threads are again used in the weaving of the fabric. The sley executes its complete movement, known as full beating. The threads wound onto the separate warp beam yield, and the pleat falls into line (c) (Marfurt, 1998).

4.1.2 Production of terry fabrics

The production of terry fabrics is a complex process and can only be realized on special designed weaving machines. Two warps are processed simultaneously in the production of terry fabrics which one of them is the ground warp that are highly tensioned and the other is the pile warp that is lightly tensioned. A special weaving method enables loops to be formed with lightly tensioned ends on either one surface or two surfaces (Adanur, 2001). Two specialized mechanisms are used in terry weaving machines such as reed control and fabric control.

Two picks are inserted at a variable distance –the loose pick distance- from the cloth fell. The loose pick distance is varied according to the desired loop height. When the third pick is beaten up, the reed pushes the pick group, on the tightly tensioned ground warps, towards the fell and loose pile warp ends woven into the pick group are uprighted and form loops. Depending on the weave, loops are thus formed on one or both sides of the fabric. In general, the reed has two beat up positions which do not impose alternative movements to the warp, fabric and various components of the weaving machine. The sley has a special mechanism built in which allows different beat-up positions for pile formation (Adanur, 2001).

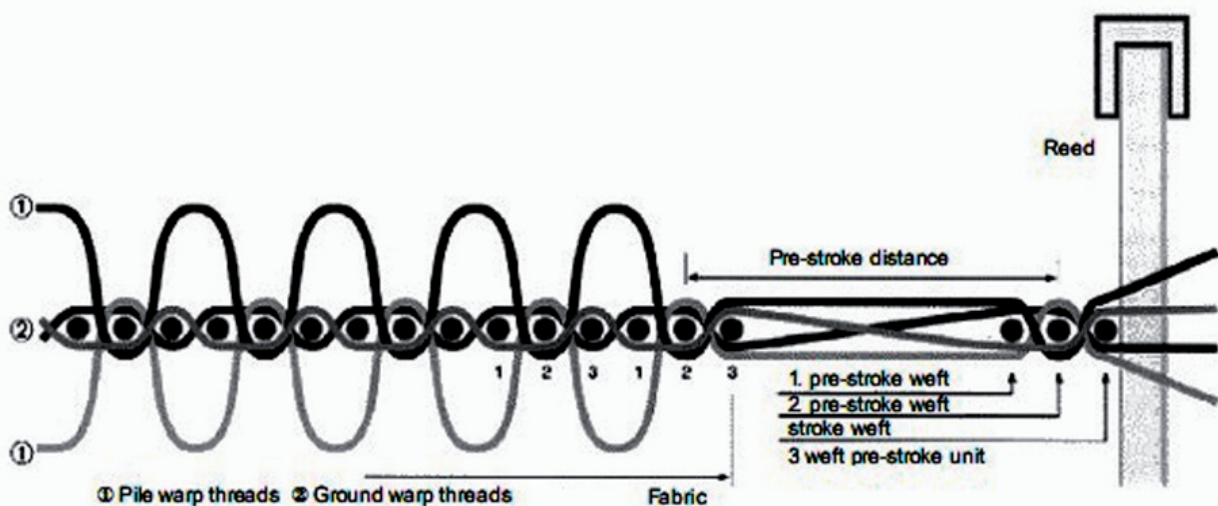

Fig. 8. Structure of a three-pick terry fabric (Adanur, 2001).

In the second system, the sley motion is constant on the other hand cloth fell is moving. Using this principle the fabric is shifted towards the reed by means of a positively controlled movement of the whip roll 6 and a terry bar together with the temples on the beat-up of the fast pick. The sturdy reed drive is free of play. It provides the necessary precision for the beat-up of the group of picks. A compact, simplified whip roll system 6 with the warp stop motions arranged on two separate levels improves handling and has a decisive influence on reducing broken ends. With the help of electronics the precision of measuring the length of pile yarn is improved. The tensions of the ground and pile warps 1 and 2 are detected by force sensors 3 and 9 and electronically regulated. In this way warp tension is kept uniform from full to the empty warp beam. To prevent starting marks or pulling back of the pile loops the pile warp tension can be reduced during machine standstill (Badawi, 2007).

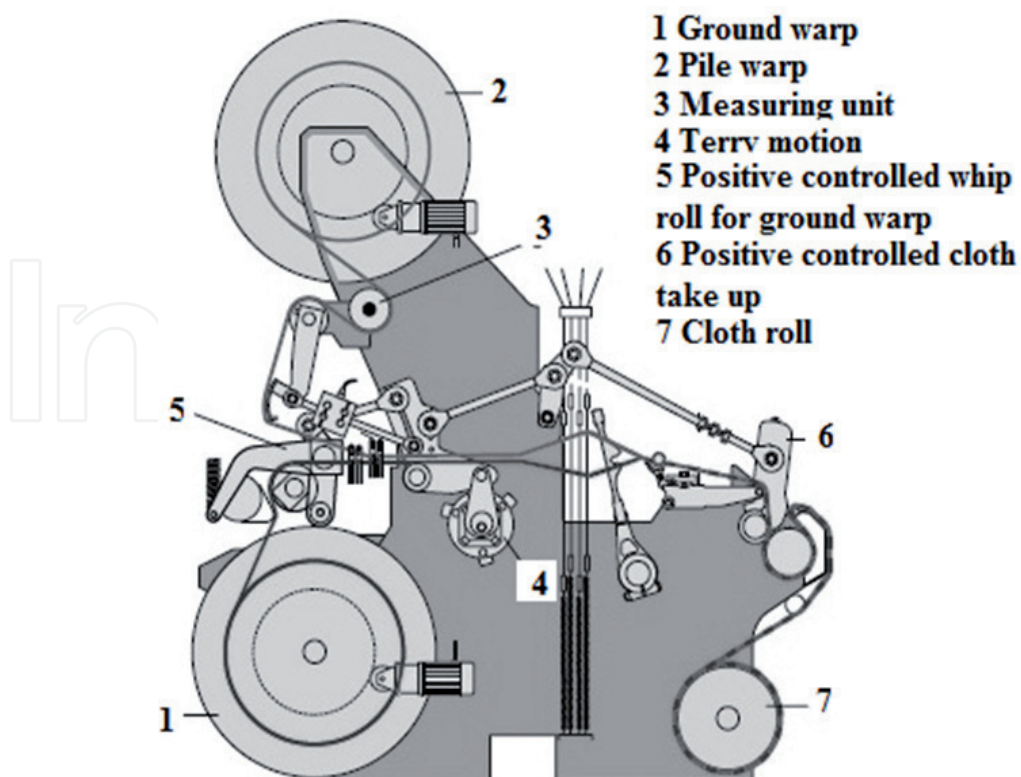

Fig. 9. Fabric control mechanism (Dornier, 2007).

4.1.3 Production of velvet fabrics

Velvet fabrics are a class of pile fabrics which are divided into two as warp pile fabrics and weft pile fabrics known as velveteen according to the pile direction. Warp pile fabrics, also known as velvet, can be produced with two weaving methods; wire weaving technique and face to face (a.k.a. double plush) weaving technique. The advantage of face to face weaving technology is two fabrics are effectively woven at the same time one above the other joined together by the pile warp ends which cross from top cloth to bottom cloth according to the design and during this weaving process a knife situated between the two cloths continuously traverses the width of the fabric cutting the pile warp threads to create two cloths each with a cut warp pile surface. It is important to appreciate that a surface pile tuft is formed only when a pile end crosses from the top cloth into the bottom cloth and is cut on the loom by the traversing knife, and it is in this way that the surface pile design and colour are created. When it is not required on the surface of the fabric the pile is woven or 'incorporated' into the ground structure either in the top or bottom cloth (Fung&Hardcastle, 2001). Therefore, two different pile structures such as cut pile or loop pile can be obtained based on the pile cut or not.

Weaving machines based on face to face weaving technique are equipped with a 3 position shedding device (dobby or Jacquard machine), so as to form two overlapped and properly spaced out sheds and to permit to the pile warp to tie up the two fabrics together. Into each of the two shed a weft is inserted, usually by means of a pair of superimposed rods driven by the same gear (Castelli et al., 2000). With this technique, 3D woven spacer fabrics can also be easily woven.

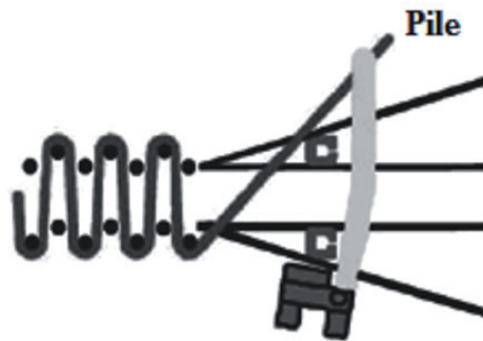

Fig. 10. Face to face weaving technique of producing velvet fabrics (Van De Wiele as cited in Chen, 2011).

In wire weaving technique, there is one set of ground warp, one set of ground weft and an extra set of warp yarns to form piles on the fabric. In order to produce a fabric with this technique, firstly a group of ground warps is raised according to the fabric pattern and the weft yarn is inserted to make its first interlacing with the ground warps. Then, pile warps are raised and a rod is inserted to the opened shed through the entire width of the fabric. To complete the weaving cycle, the remaining ground warps are raised and then again weft yarn is inserted. This weaving cycle is repeated several times; then the rods are slipped out by forming a loop pile. In order to produce cut pile velvet, rods equipped with knives can be used. In some special types of weaving machines with wire weaving techniques, for the production of velvet fabrics, weft yarn is inserted in the bottom shed of a double shed opening while steel rods or wires are inserted in the top shed to obtain piles. Pile yarns are supplied from a creel that all the ends come from a separate package utilising a negative system of yarn feed controlled by friction tension devices. Again in this method, during extraction of the wires, the piles can be cut or uncut or a combination of both. The weft insertion is performed with a rapier and weft insertion rates can be up to 200 rpm. However, the wire insertion reduces the speed of the weaving machine. Through the combination of ground warps and the weft the base fabric is obtained. The pile ends are woven over the wires and fixed into the base fabric in such a way that loops are being formed over the wires. A certain number of wires is woven into the fabric (10, 12, 16, 20 or 24 wires in total). Each wire is inserted into the shed between the weaving reed and the fabric border. The wires that are woven into the fabric are being extracted one by one from the fabric. For each insertion of a wire another wire is extracted. The wire that has been extracted is reinserted into the shed. Pile wires are specially made very fine steel rods rolled in several passages into the final dimension as requested for the specific pile height that one wants to obtain.

4.1.4 Production of spacer fabrics

Spacer fabrics can be produced both on conventional weaving and special 3D designed weaving machines. These fabrics are classified as even and uneven surfaces according to Chen (2011).

Spacer woven fabrics with even surfaces can be produced on conventional weaving machines with the weft insertion system of shuttle. The weaving loom has a conventional heddle harness (50) system comprising individual heddles 51 to 56 controlling warp yarn groups 11, 12, 21, 22, 31 and 32. As in all weaving looms, shedding and movement of the

harnesses in timed sequence with shuttle and reed movement is controlled with the shedding mechanism. Figure 12 represents the opened shedding for 21 and 22 warp yarns for weft insertion, shuttle (57). On the loom, totally three shuttles are used, one for each fabric ply. With arranging the fabric take-up motion in time sequenced with shedding mechanism, this kind of fabric can be easily woven (Koppelman&Edward, 1963).

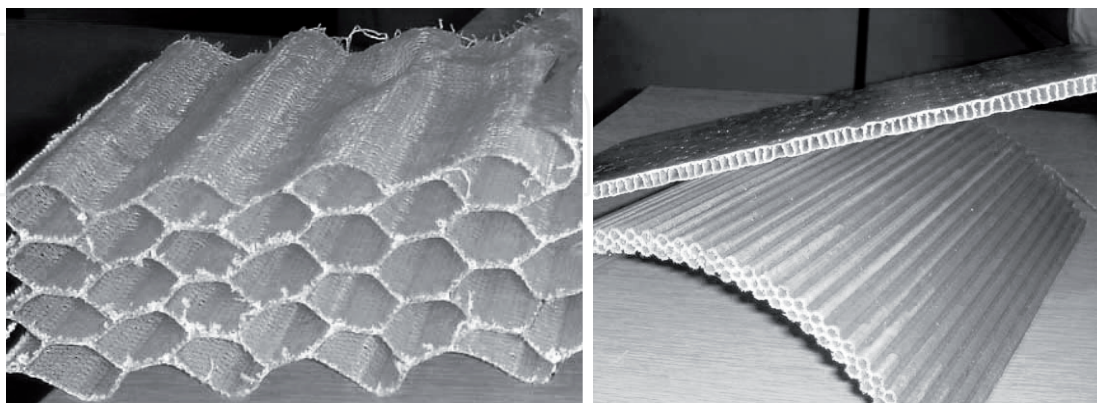

Fig. 11. Different views of spacer fabrics (Chen, 2011).

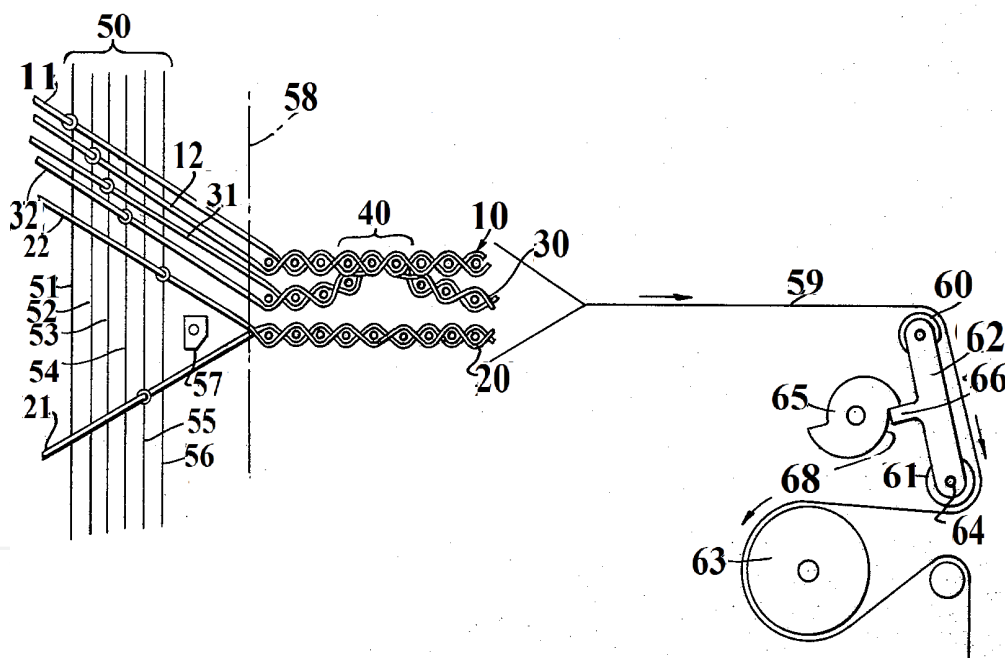

Fig. 12. Method of weaving a hollow 3D woven fabric on a conventional loom (Koppelman&Edward, 1963).

Another design of 3D spacer fabric consisting of double ribs between the bottom and top layers or a 3D spacer fabric with an I shape can be produced on a conventional weaving machine (Rheume, 1976). For the production of this type of fabric, the weaving loom has to have four separate shuttles and to include eight separate harnesses, each of which control different groups of warp yarns. Both of these two fabrics have the properties of foldability while being produced on the loom. When the fabrics are taken off the loom and get rid of the stresses, they open up and have the cross sections of V-shaped and I-shaped (Figure 13).

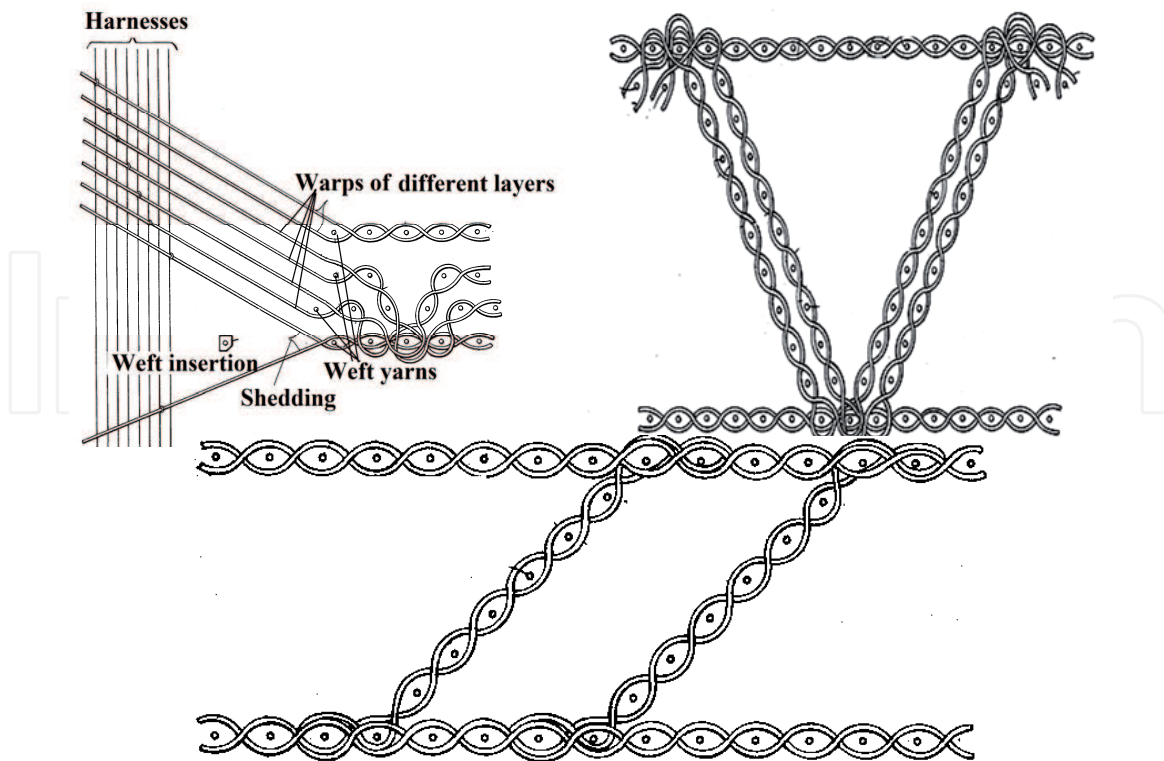

Fig. 13. Method of weaving a hollow 3D woven fabric consisting of two ribs on a conventional loom and appearance of fabric cross section and I-shaped hollow fabric (Rheume, 1976&1970).

Another type of 3D woven spacer fabric with double ribs connecting the upper and lower layers which is designed to be used in lightweight composite materials is given in Figure 14. However, the structure of this fabric is different compared to the others mentioned up to now. The double ribs connecting the top and bottom layers also constitute the upper and lower layers interchangeably. The weaving of this fabric is possible with warp-let off and fabric take up modifications of the narrow weaving machine. The weaving is performed in three stages; upper and lower ground fabrics weaving, wall-fabrics weaving, and backward movement of the floated tight yarns (formation of wall-fabric) (Badawi, 2007).

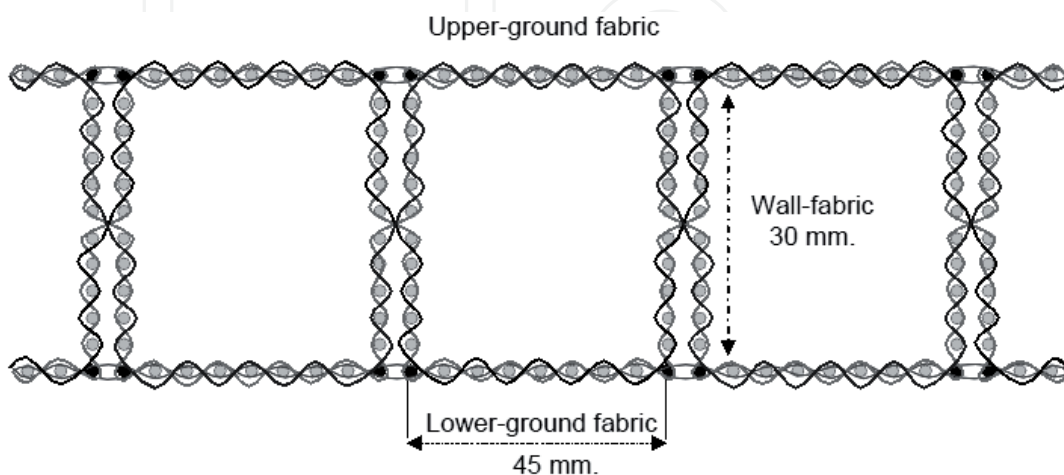

Fig. 14. The structure of 3D woven spacer fabric designed for lightweight composites (Badawi, 2007)

4.1.5 Production of shell fabrics

Shell fabrics are a special class of 3D woven fabrics since the structure of these fabrics may have only one layer or multiple layers; however the end product is always three dimensional. The importance of these types of fabrics is increasing since these types of woven fabrics are widely used in helmets, bra cups in fashion and clothing, female body armour and car door lining material (Chen&Tayyar, 2003).

Shell (a.k.a. domed) fabrics can be produced with weaving, or cut and sew. Cut and sew technique has been the most commonly method used to produce shell fabrics but seams are a big disadvantage in technical applications, where the continuity of fibres is important. Seams definitely reduce the level of reinforcement and protection. Furthermore, cut and sew creates extra waste of materials and labour (Chen&Tayyar, 2003).

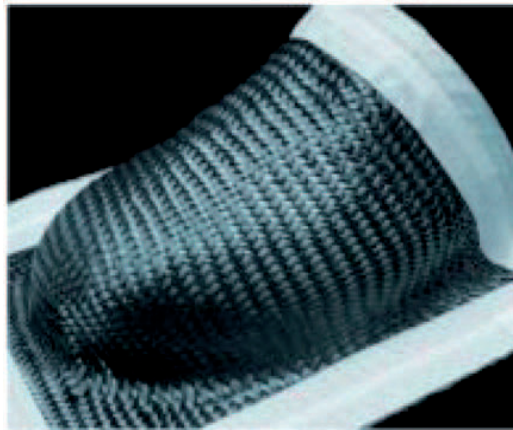

Fig. 15. An example of a shell fabric woven with conventional weaving (Busgen, 1999 as cited in Chen, 2011)

In conventional weaving, shell fabrics can be produced with using discrete take up and combination of different weaves. In order to produce a shell woven fabric, one can use a mixture of weaves with long and short floats. For instance, the plain weave, the tightest, is arranged in the middle, where a 2/2 twill is used in middle ring, and a five-end satin, with the longest average float length which is the loosest weave of the three types, is used for the outer ring. In a fabric with constant sett (the same warp and weft densities), the areas woven with plain weave tends to occupy a larger area and therefore will grow out of the fabric plane; the part of the fabric with the five-end satin tends to be squeezed, thus enhancing the domed effect. Consequently, the height difference between the lower and higher planes forms a dome. This method is a quick, easy, and economical way to produce fabrics that require relatively small domed effects. However, it appears that for fabrics requiring larger domed effects, the weave combination method is not sufficient (Chen&Tayyar, 2003).

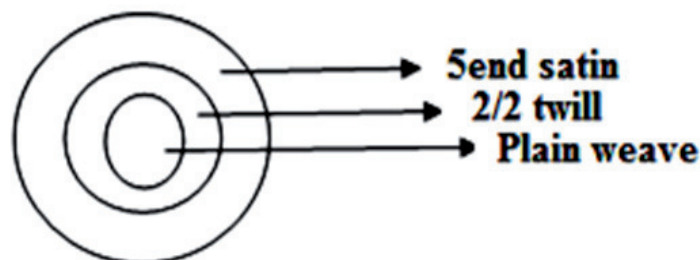

Fig. 16. Weave combination to produce shell fabric (redrawn from Chen&Tayyar, 2003)

There is a balance between warp let-off and fabric take up of the weaving machine in normal weaving. Otherwise, there will be variations in the weft density which is an undesired situation. However, in weaving of shell fabrics, the variations of the weft density are required. But these variations have to be under control. In order to achieve a controlled variation in the weft density, the width of the loom is needed to be divided into several sections and each section is required to be maintained in its own balanced fabric take up and warp let off. This can be achieved by a method in which the fabric is taken forward at different rates across the sections (Chen&Tayyar, 2003). To produce the shell fabric given in Figure 16 as an example, the loom has to be divided into three parts and three warp beams are required controlled individually. By this way, the ratio of fabric take up and warp let off will be constant in each section.

A special fabric take up system which consists of many discs electronically controlled to perform individual take-up movement, besides individually controlled warp let off system on conventional weaving machines allow producing 3D shell woven fabrics (Busgen, 1999).

4.1.6 Production of non-interlaced uniaxial orthogonal 3D fabrics

Khokar (2002) named this kind of fabrics as NOOBed fabrics which is an acronym for Non-interlacing, Orthogonally Orientating and Binding. These fabrics are different in structure when compared to the classical weaving structures (Figure 17.a). There are three different yarns that are positioned in three coordinates (x , y , and z). However, the yarns are not interlaced with each other as in the conventional weaving. Orthogonal fabrics are divided into two groups as uniaxial and multiaxial.

A conventional weaving machine is modified to produce a fabric which has three dimensions of yarns (Figure 17). In this fabric, Ground warps GW are arranged in rows and columns and are positioned in the x direction. In y direction, weft yarns are positioned and these yarns are used to bind ground warps in the row direction. In z direction, extra binder warp threads are used which are supposed to bind ground warps in the column direction (Figure 17.a). Ground warp yarns pass over a roller RL and through two sets or columns of horizontal spacing or separating bars SBR (1-5) and SBL (1-5) arranged in pairs. They pass then between heald wires. The horizontal bars SBR, SBL are designed to open a warp gap between adjacent horizontal rows or layers of ground warps to facilitate the weft insertion. For each such horizontal row, two bars are required; one of which is under appropriate row of threads and serves to raise it SBR, and the other SBL above which serves to lower it. Binder warp threads are controlled by heald frame by raising or lowering the frame. The weaving is performed as follows; when the heald frame HF is in the lowered position, all the bars SBR and SBL are also in the lowered position except SBR1 and SBL1 which are in the raised position in order to form a warp gap for the weft insertion. Thus, the first weft is inserted in the fabric. After the first weft insertion, second bars of SBR and SBL join SBR1 and SBL1 in the raised position are raised and the second weft is inserted into the warp gap. This process is continued until the last weft thread of the first vertical row of weft threads has been inserted. Then reed beats up the inserted wefts by moving forward. The heald frame HF is moved up to insert the vertical binder warp. The lowest SBR5 and SBL5 bars are lowered to form a gap for the weft insertion. Pair by pair all the bars are lowered and after each lowering, the corresponding weft is inserted until the second vertical row of weft threads is completed. Then the reed

again beats up the second row and once again the heald frame is lowered to insert the warp binder vertically (Greenwood, 1974).

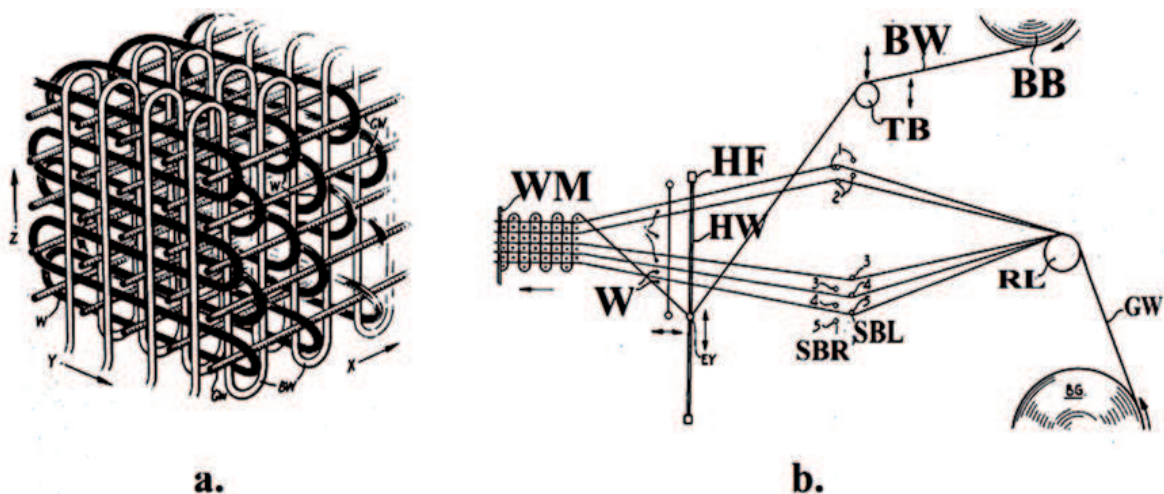

Fig. 17. An example of a uniaxial 3-D fabric and the modified conventional weaving loom (Greenwood, 1974)

Uniaxial 3D variable shaped fabric can also be produced on conventional weaving machines (Mohamed&Zhang, 1992). In this system, two groups of weft yarns, Y1 and Y2 are used for weft insertion with one weft group (Y1) being inserted from one side for the flange and other weft yarn group (Y2) being inserted from the other side for the web portion of the inverted T cross-shape (Figure 18.b). Two selvage yarns, Sa and Sb, are required to hold the

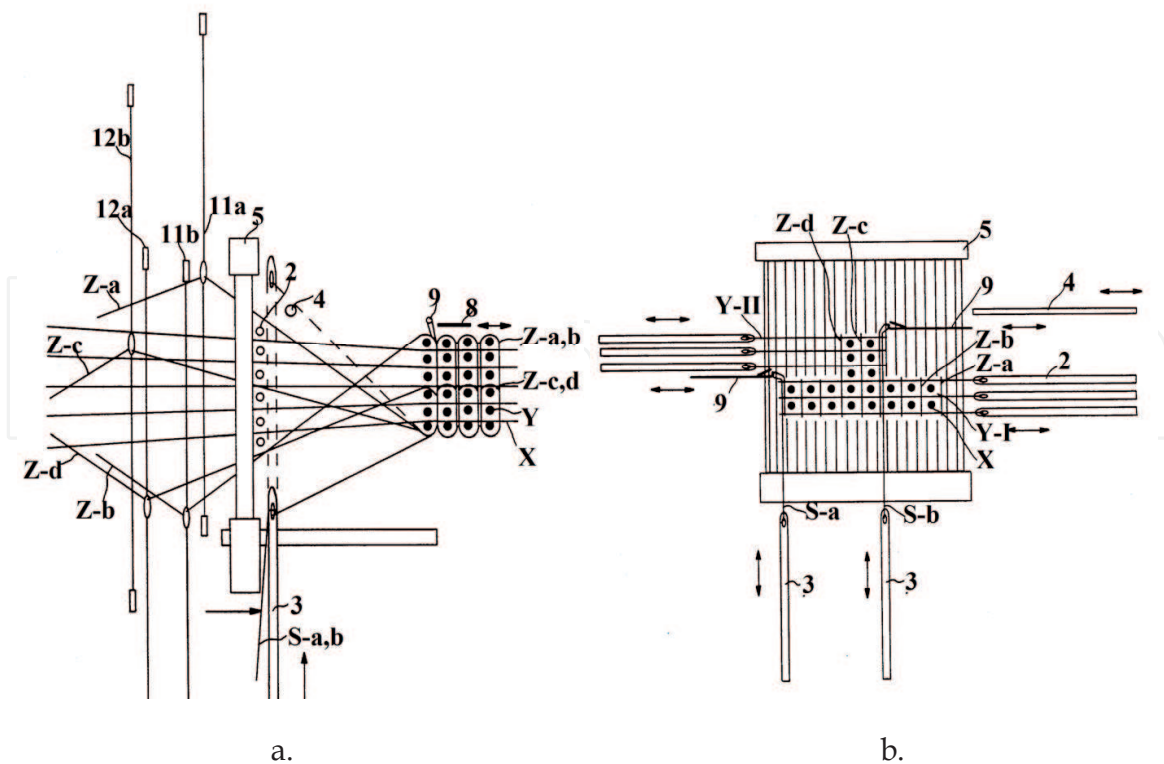

Fig. 18. Production of a uniaxial 3D variable shaped fabric on modified weaving machine (Mohamed&Zhang, 1992)

fore end loops formed by the two groups of filling yarns, Y1 and Y2, respectively. Preferably, four harnesses, 11a, 11b, 12a, 12b, are used to control two sets of vertical Z yarns, Za-Zd. One of set of Z yarns, Za, Zb, is inserted for the flange portion of the inverted T shape fabric, and the other set of Z yarns, Zc, Zd, is inserted for the web portion of the inverted T cross-sectional shape fabric (Mohamed&Zhang, 1992).

4.2 Production of 3D woven fabrics with 3D weaving

4.2.1 Production of non-interlaced uniaxial orthogonal 3-D fabrics

This method of producing an integrated nonwoven 3D fabric F (Figure 19) comprises disposal of axial yarns Z in a grid form and in accordance with the required cross sectional profile, and traversing horizontal and vertical sets of binding yarns X and Y about the corresponding rows and columns of axial yarns in a closed-loop path to bind the fabric directly. The device is essentially composed of a plate (P) having two sets of profiled tracks (D and C) existing in a mutually perpendicular configuration and in the same plane on the front face of the plate (P); two sets of binder yarn spool carriers (K and L); two pairs of tracking arrangement such that each pair is situated at the terminal sides to contain between it all the tracks of sets D and C respectively for guiding the binder yarn carriers in a closed-loop path; and openings (B) in plate (P), arranged in rows and columns, to allow the axial yarns Z to pass through, a creel (J) to supply axial yarns Z, and a fabric take-up unit (H) (Khokar, 2002).

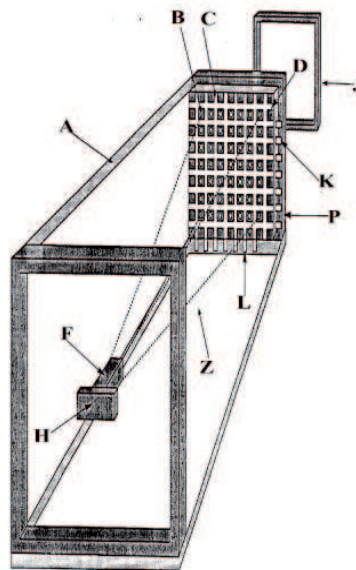

Fig. 19. Production of a uniaxial 3D fabric on a special designed 3D weaving machine (Khokar& Domeij, 1999)

The warp yarns Y are arranged in multiple layers each of which has a number of yarns which run in one horizontal plane in parallel relation with or at an equal space from adjacent yarns that are passed through a reed 1 through number of holes formed therein at uniform intervals in both horizontal and vertical directions. The warp yarns of the respective layers are in vertical alignment, forming regularly spaced vertical warp rows. Weft inserting device 6 comprises a number of elongated picking plates 7 which are spaced from each other at the same distance for secure insertion of wefts into the spaces between the respective layers of the tensioned warp yarns.

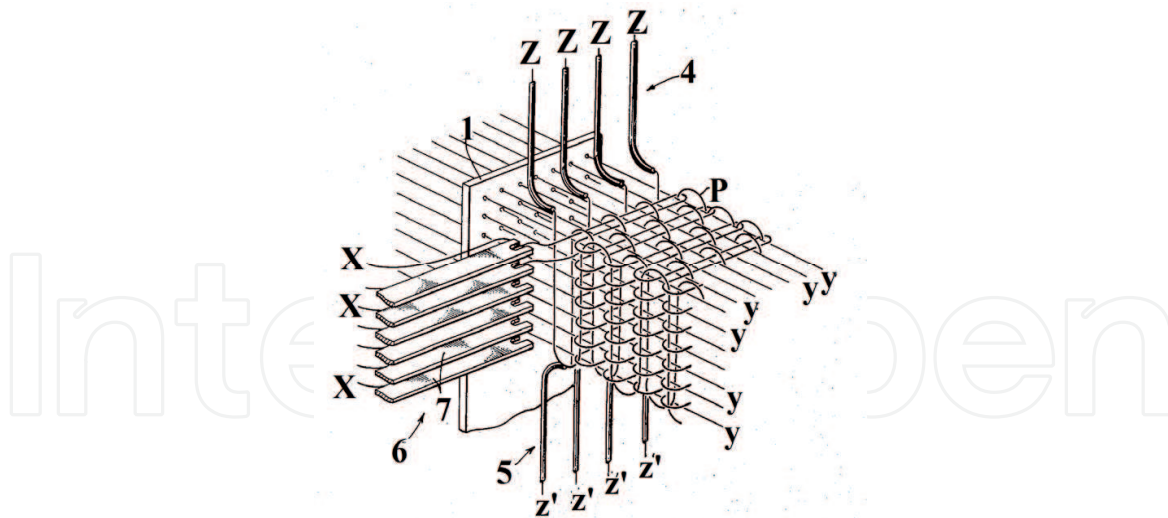

Fig. 20. Special designed 3D weaving machine that produces a uniaxial 3-D fabric (Fukuta et al., 1974).

In order to pick in weft yarns X and vertical yarns Z into the horizontally and vertically aligned warp yarns, the weft inserting device 6 is first picked transversely or perpendicularly to the warp yarns while maintaining the upper and lower vertical yarn inserting devices 4 and 5 in the upper and lower retracted positions as shown in Figure 20. Each of the weft yarns X being inserted between the warp layers in double fold forming a loop at the fore end thereof. The weft inserting device 6 is temporarily stopped when the looped fore ends of the weft yarns are projected out of the warp yarns on the opposite side for threading a binder yarn P (Fukuta et al., 1974).

As shown in Figure 21, base 10 supports movable upper and lower frames 12 and 13 with holes for supporting a plurality of filaments 15 that extends in the vertical (Z-axis) orientation. Identically working filament feed units 20 and 20' alternately insert yarns in the X- and Y-axes directions, respectively. First, filaments 21 from supply bobbins are woven through the spaced rows between filaments 15 along the X-axis by advancing the needles 22 by pushing rods 25. A pin 30 is inserted in the Y-axis direction to lie across the top of filaments 21 outside the last row of filaments 15 to tamp filaments 21 down. Needles 22 are then retracted from filaments 15, forming a tightly looped first course of X-axis filaments that is restrained by pin 30. Similarly, the course of Y-axis filaments is woven next by advancing threaded needles 22', inserting pin 30' on top of filament 21' in the X-axis direction and retracting needles 22'. As the filament layers build up, pins 30 and 30' are removed. To increase the fabric's density, all the filament layers are compressed. The fabric integrity results primarily from inter-yarn friction (King, 1976 as cited Khokar, 2002).

In Weinberg's special designed 3D weaving machine, it is possible to form sheds between layers of planar warp yarns, so that the orthogonal weft yarns can easily be inserted in any predetermined directions. Planar warp yarns are threaded through two parallel and perforated plates. The distance between these two plates is enough to accommodate the shedding and weft insertion. The top plate can slide on the warp yarns. The base plate is used to anchor the ends of the warp yarns (Weinberg, 1995).

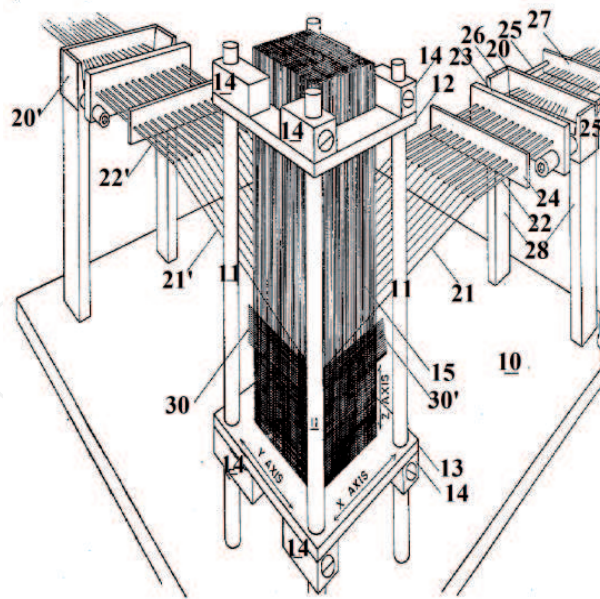

Fig. 21. King's special designed 3D weaving machine (King, 1976).

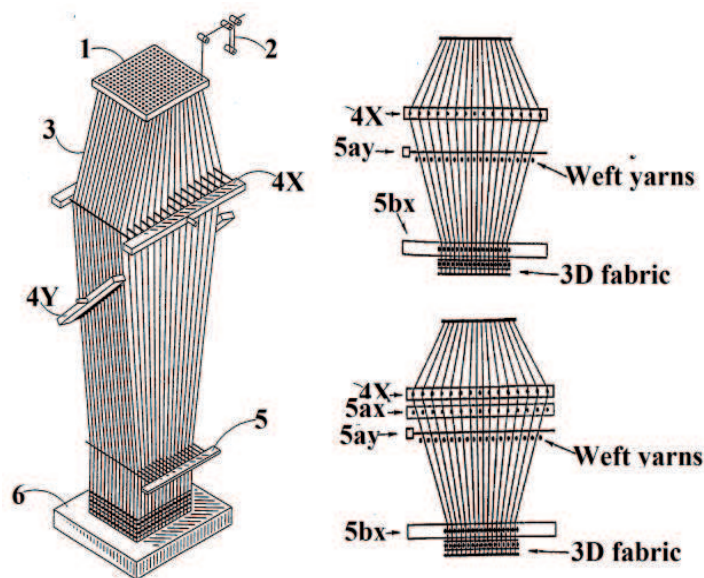

Fig. 22. Weinberg's special designed 3D weaving machine (Weinberg, 1995).

4.2.2 Production of non-interlaced multiaxial orthogonal 3D fabrics

One of the main problems using multilayer woven fabrics in preforms is insufficient in-plane and off-axis properties of composites. Conventional weaving machines which are capable of producing multilayer fabrics cannot produce fabrics that contain fibres or yarns orientated at $\pm 45^\circ$ in the plane of the preform. With conventional machines, it is only possible to manufacture fabrics with fibres or yarns orientated at angles of 0° and 90° . It is also possible to orient the fibres or yarns at angles of $\pm 45^\circ$ in through the thickness. However, these oriented yarns at the angle of $\pm 45^\circ$ in through the thickness will not affect the in-plane and off-axis properties of composites in a positive way. The more recent machinery developments have therefore tended to concentrate upon the formation of preforms with multiaxial yarns (Tong et al., 2002).

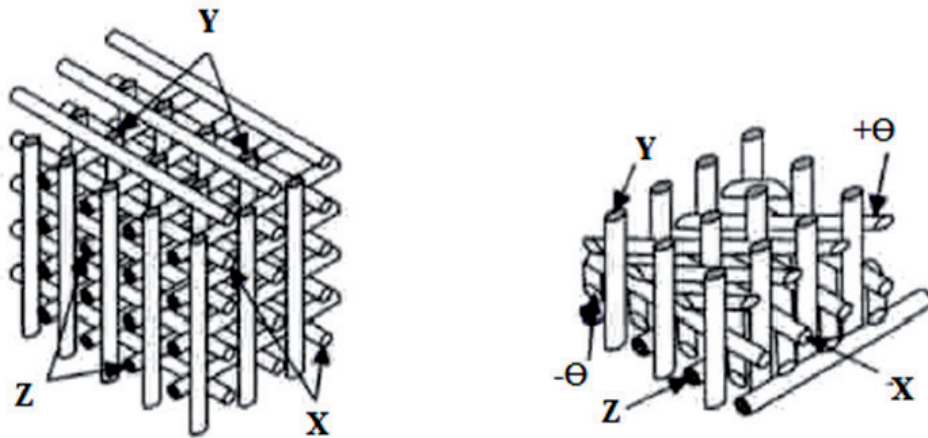

Fig. 23. Uniaxial (on the right) and multi-axial (on the left) orthogonal fabrics (Khokar, 2002).

A set of linear yarns Z , X , $\pm\theta$, arrayed in multi-axial orientation in the directions of the fabric's length, width, and two bias angles respectively, is bound using a set of binding yarns Y in the fabric-thickness direction. The yarns Y could be of either single or double type. The corresponding bindings occur above and under the set of Z , X , $\pm\theta$ yarns and they form two surfaces of the fabric. The resulting 3D fabric has the three sets of linear yarns X , Y and Z in a mutually perpendicular configuration and, additionally, the linear yarns $\pm\theta$ in bias directions (Khokar, 2002).

Anahara (1993) et al, invented a special weaving machine to manufacture a multi-axial orthogonal 3D fabric. In the aforementioned fabric, there are five axes of yarns used to construct the structure. First of all, there are warp yarns used in the length wise direction of the fabric (z). Similarly, there are weft yarns used in the width direction of the fabric (x). The first and second bias yarns B_1 and B_2 are arranged at an angular relationship of $\pm 45^\circ$. In other words, the 3D fabric F has a five axis structure in which fabrics have four axes in one plane (Figure 24) and are interconnected by the lines of the vertical yarn y .

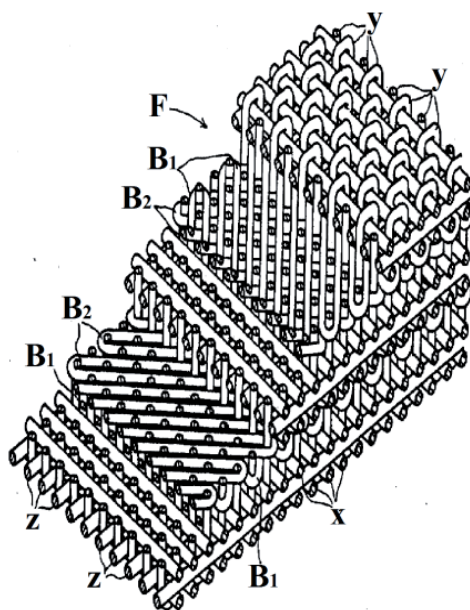

Fig. 24. Multi-axial 3D woven fabric structure (Anahara et al., 1993).

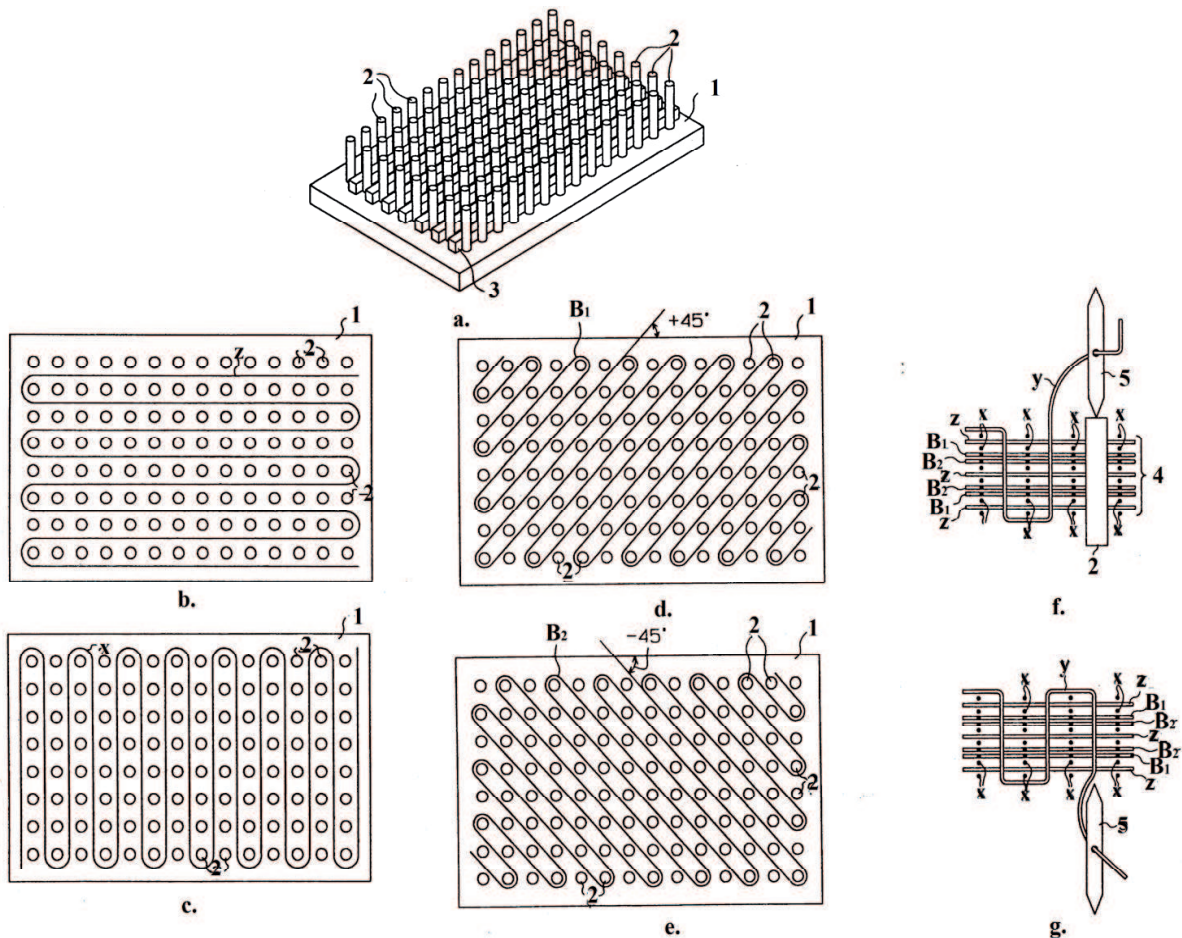

Fig. 25. Multiaxial 3D woven fabric manufacturing method (Anahara et al., 1993).

In the production of such a fabric *F*, a flat base 1 is used as shown in Figure 25 (a). There are a number of pins 2 that can be unfastened which allows the yarns to be arranged in different axes. The support bar 3 can be disposed between the pins 2 on the base 1. The lines of the weft *x*, warp *z* and first and second bias *B1* and *B2* are arranged in a way that these yarns run between the pins 2 and to be looped back, in engagement with those pins 2 which are located along the peripheral portion of the base 1. The weft layer, warp layer and bias yarn layers are inter-laminated in order. Firstly, the lines of warp yarns *z* are arranged in parallel in the length wise direction of the fabric in a way that they are being repeatedly looped back and forth around the pins 2 as shown in Figure 25 (b). Similarly, the lines of weft yarns *x* are arranged in parallel in the width direction of the fabric in such a way that they are being looped back and forth around pins 2 located at the right and left sides of the base 1 shown in Figure 25 (c). as shown in Figure 25(d), the lines of bias yarns *B1* are inserted at an angle of $+45^\circ$ with respect to the lengthwise direction of the fabric while being repeatedly looped back and forth around the pins 2. Similarly, the lines of bias yarns *B2* are inserted again in the length wise direction of the fabric that are being repeatedly looped back and forth around pins 2 however at the angle of -45° as shown in Figure 25(e). After the individual layers are completed one on another in a predetermined order, the pins 2 are removed from the base and are replaced by vertical warp yarns *y* through a needle Figure 25(f and g) (Anahara et al., 1993).

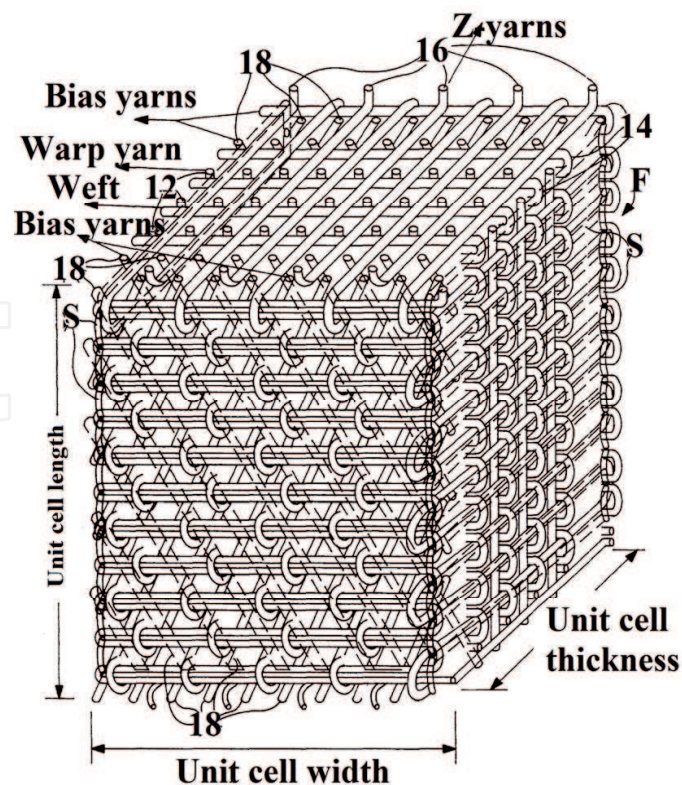

Fig. 26. Multi-axial 3D orthogonal woven fabric (Mohamed et al., 1995).

In the invention of Mohamed et al., the woven preform consists of multiple warp layers 12, multiple weft yarns 14, multiple z yarns 16 that are positioned in the fabric thickness and \pm bias yarns as shown in Figure 26. The \pm bias yarns 18 are located at the back and front of the fabric which are connected with the other sets of z yarns. In the manufacturing of this preform, warp yarns 12 are arranged in a matrix of columns and rows based on the required cross-sectional shape. After bias yarns oriented at $\pm 45^\circ$ to each other on the surface of the preform, weft yarns 14 are inserted between the rows of warp yarns and loops of weft yarns are locked with the help of two selvages at both edges of the fabric. Z yarns 16 are then inserted and passed across each other between the columns of warp yarns 12 to cross weft yarns 14 in place. The weft insertion takes place again as mentioned before and the yarns are returned to their initial positions. Z yarns 16 are now returned to their starting positions passing between the columns of warp yarn 12 by locking $\pm 45^\circ$ bias yarns 18 and weft yarns in their place. The inserted yarns are beaten up against the fabric formation line and a take up system removes the fabric from the weaving zone. This is only a one cycle of the machine. By repeating this cycle, 3D multi-axial orthogonal woven fabric can be produced within the desired fabric length (Mohamed et al., 1995).

A three-dimensional multi-axial cylindrical woven fabric (Figure 27) having a core, comprises five sets of yarns: axial (14), circumferential (16), radial (18) and two sets of bias yarns (12) that are orientated $\pm 45^\circ$ with reference to the longitudinal axis of the cylindrical fabric. The bias yarns (12) occur at the outer and inner surfaces. The fabric is produced using a multi-axial circular weaving apparatus (100) that comprises mainly four units: feeding unit (110), machine bed (130), beat-up unit (180) and take-up unit (190). The steps in the operation of the weaving machine are: rotation of positive and negative bias yarn carriers by

one carrier distance; rotation of circumferential yarn carriers by one carrier distance; moving radial yarn carriers between outer and inner edges of the machine bed; beating-up the inserted yarns; and taking-up the woven preform from the weaving zone (Bilisik, 2000 as cited in Khokar, 2002).

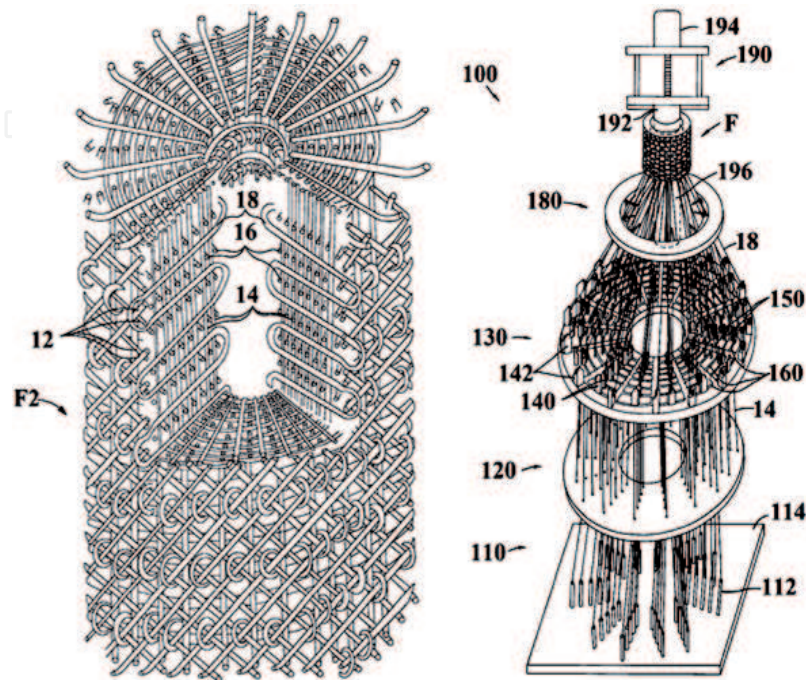

Fig. 27. Multiaxial 3D circular woven fabric structure and apparatus (Bilisik, 2000).

4.2.3 Production of interlaced 3D fabrics

The aim of producing a full interlaced 3D woven fabric is to provide a flexible-structure composite which exhibits high mechanical strength against repeatedly exerted loads and, at the same time, enjoys the advantage of light weight. This process is first developed by Fukuta (Fukuta et al., 1982).

In this manufacturing method, X and Y referred as horizontal and vertical weft yarns respectively, are interlaced with the rows and columns of Z multi-layer warp yarns respectively. In this method, shedding of multi-warp Z yarns is not performed only in the fabric thickness direction like in orthogonal 3D fabric formation but it is performed also across the fabric width. To do this, a dual shedding is needed.

In addition to dual shedding that enables column-wise and row-wise sheds to be formed, in order to produce a fully interlaced 3D woven fabric; a grid-like multiple-layer warp (Z), and two orthogonal sets of wefts (X—set of horizontal wefts and Y—set of vertical wefts) are required (Khokar, 2001).

The dual shedding is performed as shown in Figure 29 (a-i). In Figure 29 (a), the grid-like multiple layer warp yarns Z are in their initial position. Multiple synchronized column-wise sheds are formed (Figure 29 (b)) in which vertical wefts Y are to be inserted (Figure 29(c)) and after the insertion of vertical weft yarns Y all the sheds are closed. The produced fabric structure up to now is given in Figure 29 (d) which is a result of interlacement of vertical

weft yarns Y and grid-like warp yarns Z. Then the warp yarns Z are subjected to form a shed in the row-wise direction (Figure 29 (f)) into which horizontal weft yarns X are to be inserted (Figure 29(g)). The result of interlacing horizontal weft yarns X and grid-like warp yarns Z are shown in Figure 29(h). When the operations of column-wise and row-wise shedding are performed sequentially, and the corresponding wefts are inserted backward and forward in the aforementioned sheddings, the structure of plain-weave 3D fabric is formed that is shown in Figure 29(i).

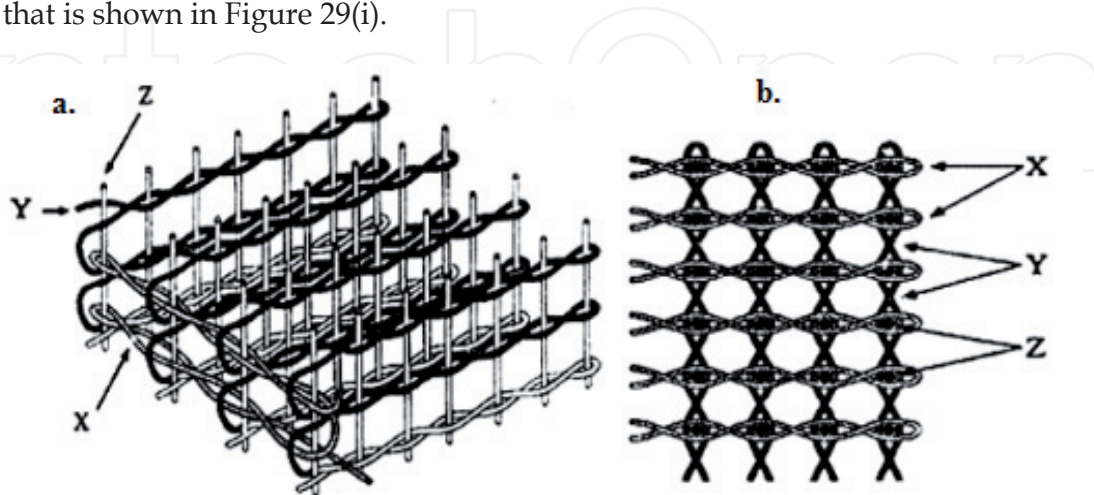

Fig. 28. Fully interlaced 3D woven fabric structure isometric view (a) and orthogonal view (b) (Fukuta et al., 1982).

However, these fabrics suffer from the crimp and fibre damage problems (Mohamed & Bogdanovich, 2009). As the shedding operation alternately displaces the grid-like arranged warp yarns Z in the thickness and width directions, two mutually perpendicular sets of corresponding vertical wefts Y and horizontal wefts X are inserted into the created sheds. The warps Z, therefore, interlace with the sets of vertical Y and horizontal X wefts, thus creating a fully interlaced 3D woven fabric. Due to the interlacing, the resulting structure has crimped fibres in all three directions, which would be detrimental for potential applications of this type of fabric as a composite reinforcement

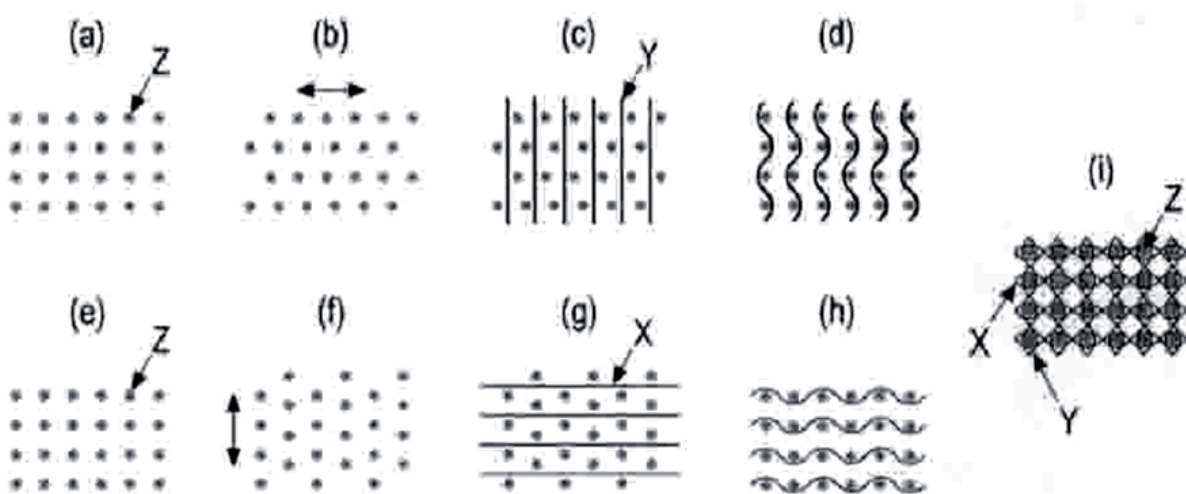

Fig. 29. Dual-directional shedding and corresponding picking for weaving fully interlaced 3D fabric (Khokar, 2001).

5. Advantages of 3D weaving process

The production of 3D woven fabrics on conventional weaving machines is an inefficient process since conventional 2D weaving machine inserts weft yarns one at a time. Contrary to the aforementioned situation, 3D weaving looms that are special designed to produce 3D woven fabrics allow simultaneously insert multiple layers of warp yarns and weft yarns. The simultaneous insertion of an entire column of weft yarns makes the linear productivity of the 3D weaving process independent of layers (Lienhart, 2009).

Another important distinction is that in 2-D weaving process, yarns in the warp direction are passed through heddles, and must be pulled past neighbouring warp yarns, above or below the filling insertion. Repeated motions through the heddles and through other planes of warp tend to abrade fibres, especially brittle technical fibres. In the 3-D Weaving process individual warp planes do not pass through heddles, and are not forced to repeatedly cross neighbouring warp planes; accordingly, weaving-induced fibre damage in this case is significantly reduced (Lienhart, 2009).

6. Comparison of preforms produced from 2D and 3D woven fabrics

3D woven preforms were first developed in 1970's in an attempt to replace expensive high temperature metal alloys in aircraft brakes (Mouritz et al., 1999). In order to produce the preform of the brake component that was produced with 3D weaving process, Avco Corporation developed a specialised 3D weaving loom that performs weaving of hollow cylindrical preforms in which carbon fibres were aligned in radial, circumferential and axial directions. Research and development of 3D woven preforms remained at a low level until the mid-1980s since problems of using traditional 2D laminates in aircraft structures were encountered. One of the main problems that was faced at that time by the aircraft manufacturers was preforms produced from traditional 2D laminates were expensive to produce complex structures. The second problem was the low impact resistance of the traditional 2D laminates since aircraft maintenance engineers complaint of damage impacts from dropped tools during maintenance. These problems led more research and development in the field of composites produced from 3D woven fabrics. Nearly thirty years of know-how in the field of 3D weaving makes the preforms produced from 3D woven fabrics have superior properties compared to those of the preforms produced from traditional 2D laminates.

While preforms produced from traditional 2D laminates can only be processed into relatively simple and slightly curved shapes, preform for a composite component with a complicated shape can be made to the near-net-shape with 3D weaving. This ability of 3D weaving producing near-net-shape preforms can reduce the production costs thanks to the reduction in material wastage, need for machining and joining, and the amount of material handled during lay-up.

The second advantage of 3D weaving is preforms can be produced on conventional weaving looms only by making minor modifications to the machinery. This minimises the investment cost of producing preforms made of 3D woven fabrics. However, a range of specialised looms have been developed that have higher weaving speeds and are capable of weaving more complex shapes than traditional looms which have been modified (Mouritz et al., 1999).

With the use of 3D weaving, fabrics having different through-thickness properties can be produced. Amounts and types of binder yarns such as carbon, glass, Kevlar and ceramic fibres in through-thickness can be used to tailor the properties of a composite for a specific application (Mouritz et al., 1999).

Composites produced from 3D woven fabrics have higher delamination resistance, ballistic damage resistance and impact damage tolerance. These aforementioned properties have been a major problem in composites produced with traditional 2D weaving used in military aircraft structures (Mouritz et al., 1999).

7. Conclusion

Today, textile structural composites are widely used in many application fields that usually consist of stacked layers known as 2D laminates, exhibit better in-plane strength and stiffness properties compared to those of metals and ceramics. However, the application of 2D laminates in some critical structures in aircraft and automobiles has also been restricted by their inferior impact damage resistance and low through thickness mechanical properties when compared against the traditional aerospace and automotive materials such as aluminium alloys and steel. In order to improve interlaminar properties of the 2D laminates, three dimensional (3D) textile preforms have been developed by using different manufacturing techniques like weaving, knitting, braiding, and stitching. Among these manufacturing techniques, sewing and 3D weaving are the promising technologies which address the shortcomings of the stack-reinforced composites.

In order to comprehend 3D weaving technology and its products, the production techniques and their principles have been reviewed in detail within this chapter.

8. References

- Adanur S. (2001). *Handbook of Weaving*, Technomic, ISBN 1-58716-013-7, Pennsylvania, USA.
- Anahara, M., Yasui, Y., Sudoh, M. and Nishitani, M. (1993). *Three Dimensional Fabric with Symmetrically Arranged Warp and Bias Yarn Layers*, Patent No. USP 5 270 094.
- Badawi S.S. (2007). *Development of the Weaving Machine and 3D Woven Spacer Fabric Structures for Lightweight Composites Materials*, PhD Thesis, Technical University of Dresden, Dresden, Germany.
- Behera B.K., Mishra R. (2008). 3-Dimensional Weaving, *Indian Journal of Fibre&Textile Research*, Vol.33, pp.274-287.
- Bilisik K. (2011). Multiaxis Three Dimensional (3D) Woven Fabric, In: *Advances in Modern Woven Fabrics Technology*, Vassiliadis S., pp.79-106, InTech, Retrieved from: <http://www.intechopen.com/books/show/title/advances-in-modern-woven-fabrics-technology>
- Bilisik K. (2010). Multiaxis 3D Weaving: Comparison of Developed Two Weaving Methods (Tube-Rapier Weaving versus Tube-Carrier Weaving) and Effects of Bias Yarn Path to the Preform Properties. *Fibers and Polymers*, Vol.11, No.1, pp.104-114

- Bilisik, A.K. (2000). *Multiaxial Three-dimensional (3-D) Circular Woven Fabric*, Patent No. USP 6 129 122.
- Bogdanovich A.E. (2007). Advancements in Manufacturing and Applications of 3-D Woven Preforms and Composites, *Sixteenth International Conference on Composite Materials (ICCM-16)*, Kyoto, Japan, July 8-13 2007
- Busgen A. *Woven fabric having a bulging zone and method and apparatus of forming same*. Patent No. US6000442, 1999
- Castelli G., Maietta S., Sigrisi G., Slaviero I.M., (2000). *Reference Books of Textile Technology: Weaving*, Italian Association of Textile Machinery Producers Moral Body, Milano, Italy.
- Chen X., Taylor L.W., Tsai L.J. (2011). An Overview on Fabrication of Three-Dimensional Woven Textile Preforms for Composites, *Textile Research Journal*, Vol. 81, No.9, pp. 932-944
- Chen X., Tayyar A.E. (2003). Engineering, Manufacturing, and Measuring 3D Domed Woven Fabrics. *Textile Research Journal*, Vol.73, No.5, pp.375-380.
- Chen X., Spola M., Paya J. G., Sellabona P. M. (1999). Experimental Studies on the Structure and Mechanical Properties of Multi-layer and Angle-interlock Woven Structures, *Journal of the Textile Institute*, Vol.90:1, pp.91-99.
- Chou T. W. (1992). *"Microstructural Design of Fibre Composites"*, Cambridge University Press, ISBN 978-0-521-35482-0, New York, USA
- Dornier, (2007). ServoTerry, In: *Lindauer Dornier*, 03.10.2011, Available from: http://www.lindauerdornier.com/weaving-machine/servoterryae/air-jet-terry-weaving-machine?set_language=en&redirect=1
- Encyclopædia Britannica. (2011). Composite Material, In: *Encyclopædia Britannica Online*, 25.09.2011, Available from: <http://www.britannica.com/EBchecked/topic/130093/composite-material>
- Fukuta K., Nagatsuka Y., Tsuburaya S., Miyashita R., Sekiguti J., Aoki E., Sasahara M., (1974). Three dimensional fabric and method and loom construction for the production thereof. Patent No. USP 3834424.
- Fukuta, K., Onooka, R., Aoki, E., Tsuburaya, S. (1982), A three-dimensional latticed flexible-structure composite, Patent No. USP 4336296.
- Fung W., Hardcastle M. (2001). *Textiles in Automotive Engineering*, Woodhead Publishing Ltd., ISBN 1-85573-493-1, Cambridge, England.
- Gokarneshan N., Alagirusamy R.(2009). Weaving of 3D fabrics: A critical appreciation of the Developments. *Textile Progress*, Vol. 41, No. 1, pp. 1-58
- Greenwood, K. (1974). *Loom*, US Patent No. 3818951.
- Hearle J. W.S., Chen X. (2009). 3D Woven Preforms and Properties for Textile Composites, *Seventeenth International Conference on Composite Materials*, Edinburgh, UK, July 27-31 2009
- Khokar N. (2002). Noobing: A Nonwoven 3D Fabric forming Process Explained, *Journal of the Textile Institute*, Vol.93, No.1, pp. 52-74.
- Khokar, N. (2001). 3D-Weaving: Theory and Practice, *Journal of the Textile Institute*, Vol.92 No.2, pp.193-207.

- Khokar N., Domeij, T. (1999). Device for Producing Integrated Nonwoven Three-dimensional Fabric. Sweden. Patent No. SE 509 944.
- King, R.W. (1976). Apparatus for Fabricating Three-Dimensional Fabric Material. US Patent No. 3955602.
- Koppelman, E., Edward A.R. (1963). *Woven Panel and Method of Making Same*, US Patent No. 3090406.
- Lienhart B. (2009). 3Tex Preforms - The Metal Alternative, 3Tex Company Brochure.
- Lord, P.R., Mohamed, M.H. (1982). *Weaving: Conversion of Yarn to Fabric* (Second Edition), Merrow Publishing Co., ISBN 0-900-54178-4, Watford, England.
- Marfurt, P. (1998), Decorative Pleats, In: *Sulzer Technical Review 1/98*, 02.10.2011, Available from: http://www.sulzerpumps.com/PortalData/7/Resources/03_NewsMedia/S TR/1998/1998_01_marfurt_e.pdf
- Mohamed M. H., Bogdanovich A. E. (2009) Comparative Analysis of Different 3D Weaving Processes, Machines and Products, *Proceedings of 17th International Conference on Composite Materials (ICCM-17)*, July 27-31, 2009, Edinburgh, UK
- Mohamed M. H., Zhang Z.H. (1992). *Method of Forming Variable Cross Sectional Shaped Three Dimensional Fabric*, US Patent No. 5085252.
- Mohamed, M.H. and Bilisik, A.K. (1995). *Multi-layer Three-dimensional Fabric and Method for Producing*, US Patent No. 5 465 760.
- Mouritz A.P., Bannister M.K., Falzon P.J., Leong K.H. (1999). Review of Applications for Advanced Three-Dimensional Fibre Textile Composites. *Composites: Part A*, Vol.30 pp.1445-1461
- Naik N.K., Azad SK. N.M., Durga Prasad P., Thuruthimattam B. J. (2001). Stress and Failure Analysis of 3D Orthogonal Interlock Woven Composites, *Journal of Reinforced Plastics and Composites*, Vol. 20, No. 17, pp.1485-1523
- Naik N.K., Azad SK. N.M., Durga Prasad P. (2002). Stress and Failure Analysis of 3D Angle Interlock Woven Composites, *Journal of Composite Materials*, Vol. 36, No. 1, pp.93-123
- Padaki N.V., Alagirusamy R., Deopura B. L., Fanguero R., (2010). Studies on Preform Properties of Multilayer Interlocked Woven Structures Using Fabric Geometrical Factors. *Journal of Industrial Textiles*, Vol. 39(4) pp.327-345
- Peters, S.T. (1998). Introduction, Composite Basics and Road Map, In: *Handbook of Composites*, Peters, S.T., pp.1-21. Chapman&Hall, ISBN 0-412-54020-7, London, UK
- Rheaume J.A. (1970). Three-dimensional woven fabric. Patent No. US3538957.
- Rheaume J.A. (1976). Multi-ply woven article having double ribs. Patent No. US3943980.
- Rouette H.K. (2002). *Encyclopedia of Textile Finishing*, Springer, ISBN 3-540-65490-9.
- Soden J.A., Hill J. (1998). Conventional Weaving of Shaped Preforms for Engineering Composites, *Composites Part A*, Vol.29A pp.757-762
- Stig F. (2009). *An Introduction to the Mechanics of 3D-Woven Fibre Reinforced Composites*, Licentiate Thesis, Stockholm, Sweden.
- Tong L., Mouritz A.P. and Bannister M.K. (2002). *3D Fibre Reinforced Polymer Composites*, Elsevier, ISBN 0-08-043938-1, Netherlands.

Weinberg, A. (1995). Method of Shed Opening of Planar Warp for High Density Three Dimensional Weaving. US Patent No. 5449025.

Zhang, C. (2003). *Characterization and Modelling of 3D Woven Composites*, PhD Thesis, North Carolina State University, Raleigh, USA.

IntechOpen

IntechOpen

© 2012 The Author(s). Licensee IntechOpen. This is an open access article distributed under the terms of the [Creative Commons Attribution 3.0 License](#), which permits unrestricted use, distribution, and reproduction in any medium, provided the original work is properly cited.

IntechOpen

IntechOpen