

We are IntechOpen, the world's leading publisher of Open Access books Built by scientists, for scientists

4,800

Open access books available

122,000

International authors and editors

135M

Downloads

Our authors are among the

154

Countries delivered to

TOP 1%

most cited scientists

12.2%

Contributors from top 500 universities

**WEB OF SCIENCE™**Selection of our books indexed in the Book Citation Index
in Web of Science™ Core Collection (BKCI)

Interested in publishing with us?
Contact book.department@intechopen.com

Numbers displayed above are based on latest data collected.

For more information visit www.intechopen.com

Fuzzy Inference Systems Applied to the Analysis of Vibrations in Electrical Machines

Fredy Sanz, Juan Ramírez and Rosa Correa
*Cinvestav
Mexico*

1. Introduction

Within industry, the concept of maintenance can be handled in different ways. It can be done periodically at predefined times, according to the type of machine, and according to the manufacturers' recommendations. In this case, it is referred to as scheduled preventive maintenance. Maintenance done when there is faulty equipment is commonly called corrective maintenance. Employing electrical machines' operating signals may be useful for diagnosis purposes.

Three-phase electrical machines such as induction motors or generators are used in a wide variety of applications. In order to increase the productivity and to reduce maintenance costs, condition monitoring and diagnosis is often desired. A wide variety of conditioning monitoring techniques has been introduced over the last decade. These include the electric current signature and stator vibrations analysis (Cusido & Romeral & Ortega & Espinoza, 2008; Blodt & Granjon & Raison & Rostaing, 2008; Blodt & Regnier & Faucher, 2009; Riera & Daviu & Fulch, 2008).

Nowadays, industry demands solutions to provide more flexible alternatives for maintenance, avoiding waste of time in case of major requirements to unforeseen failures, as well as time of scheduled maintenance. This creates the necessity to propose and implement predictive technologies, which ensure that machinery receive attention only when they present some evidence of their mechanical properties deterioration (Taylor, 2003). Vibrations have been one of the usual machinery's physical state indicators.

Some issues related to failures in machinery are as follows:

1. Different problems can be apparent with the same frequency. For example, the unbalance, the one-axis flexion, the misalignment or some resonances, all can be apparent within the same frequency interval. Likewise, a machine may vibrate due to problems related with another machine to which it is coupled.
2. Models do not precisely represent the machine's behavior, since frequently studies assume that the constituent parts and load mechanics are perfectly symmetric. Likewise, in the electrical motor's case, normally it is assumed that electrical sources are balanced.

3. The precise analysis of a problem at a given frequency depends on the presence of one or more related frequencies. In the current methods, an important difficulty is the need to monitor through sophisticated sensors. Additionally, failures detection depends on the load's inertia.

Different detection techniques for machines' state monitoring have been studied. Some techniques are based on analyzing electrical signals, some others are based on vibration measurements, and some combine them. In this paper, vibration measurements are used for monitoring purposes.

Vibrations must be properly evaluated, especially those associated to rotating machinery. Capturing vibration patterns, using identification techniques and signal processing, distinctive signatures for failures detection can be set. This could help to anticipate the occurrence of equipment damage, and therefore, corrective actions can be taken to avoid the high cost of a partial or total machinery replacement, as well as economic expenses caused by their unavailability.

2. Preliminaries

In this research, historical developments around the vibration analysis have been reviewed, while the use of emerging technologies are proposed to identify failures in rotating electrical machines. Through a wavelet decomposition, it is possible to extract information that enables the detection of signal changes under significant vibrations, affecting the equipments' useful life. The vibration signals have been utilized to detect failures in rotating electrical machines. However, the use of Fourier-based techniques is not practical, because such techniques need stable and long-term records.

No given rules exist to allow characterization of the type of machine, size, or even some specific operating characteristics through vibration patterns. It is relevant to establish strategies able to identify a failure, and even to differentiate among the types of failures. Thus, the neural networks may be quite useful. Through learning elements, neural networks are able to infer the actual conditions of the system under analysis. In this application, the Adaptive Network Based Fuzzy Inference System (ANFIS) has been selected for such purposes.

ANFIS is an Artificial Neuro-Fuzzy Inference System, which is functionally equivalent to fuzzy inference systems. It represents a Sugeno-Tsukamoto fuzzy model, that uses a hybrid learning algorithm (Omar, 2010; Jang, 1993; Jang & Sun, 1996; Bonissone & Badami & Chiang & Knedkar & Schutter, 1996; Jang & Gulley, 1995; Michie & Spreghelhart & Taylor, 1994).

2.1 Fuzzy inference systems

It is necessary to study other alternatives because the system models based on conventional mathematical tools, like differential equations, is not well suited for dealing with ill-defined and uncertain systems (Proakis, 2001). Through the use of vibration signals, it is possible to implement tools able to differentiate characteristics to establish the electrical machine's conditions. A fuzzy inference system employing fuzzy *if-then* rules can model the qualitative aspects of human knowledge and reasoning processes without employing precise

quantitative analyses. The fuzzy modeling or fuzzy identification, was first explored systematically by Takagi and Sugeno (Takagi & Sugeno, 1985). There are some basic aspects of this approach that require some comments. In particular:

1. Vibration signals in electrical machines have information, which can be used to predict the machine's state. Figure 1, shows the basic inference composition.
2. Patterns captured under different conditions may be similar, therefore it is necessary an inference system that facilitates the identification process.

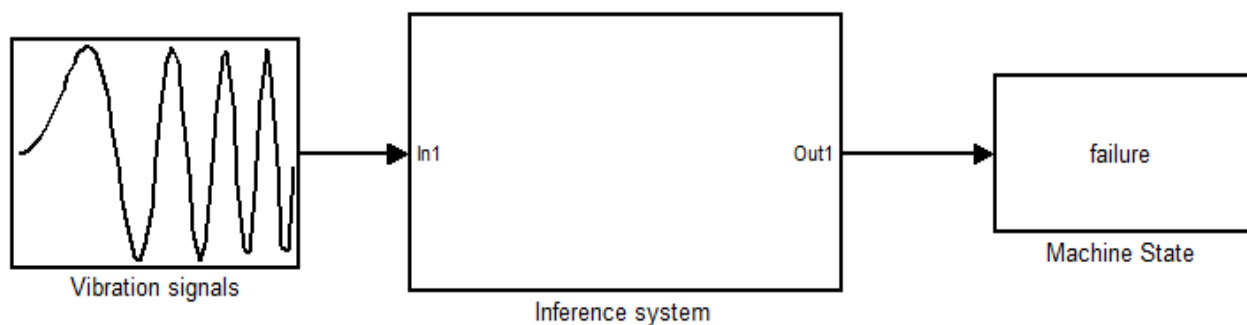

Fig. 1. Basic inference system

2.2 Fuzzy if-then rules

Fuzzy *if-then* rules or fuzzy conditional statements are expressions of the form *IF A THEN B*, where A and B are labels of fuzzy sets (Zadeh, 1965) characterized by appropriate membership functions. Due to their concise form, fuzzy *if-then* rules are often employed to capture the imprecise modes of reasoning that play an essential role in the human ability to make decisions in an environment of uncertainty and imprecision. An example that describes a simple fact is:

If vibration is high, it is possible the bars' failure

where *vibration* and *failure* are linguistic variables (Jang, 1994); *high* (*small*) are linguistic values or labels that are characterized by membership functions.

A different form of fuzzy *if-then* rules, proposed by (Omar, 2010; Takagi & Sugeno, 1985, as cited in Jang, 1993), have fuzzy sets involved only in the premise part. Both types of fuzzy *if-then* rules have been used extensively in both modeling and control. Through the use of linguistic labels and membership functions, a fuzzy *if-then* rule can easily capture the spirit of a "rule of thumb" used by humans. From another point of view, due to the qualifiers on the premise parts, each fuzzy *if-then* rule can be viewed as a local description of the system under consideration. Fuzzy *if-then* rules form a core part of the fuzzy inference system described in the following.

2.3 Fuzzy inference system structure for vibration analysis

Fuzzy inference systems are also known as fuzzy-rule-based systems, fuzzy models, fuzzy associative memories (FAM), or fuzzy controllers when used as controllers. Basically, a fuzzy inference system is composed by five functional blocks (Jang, 1993), Fig. 2.

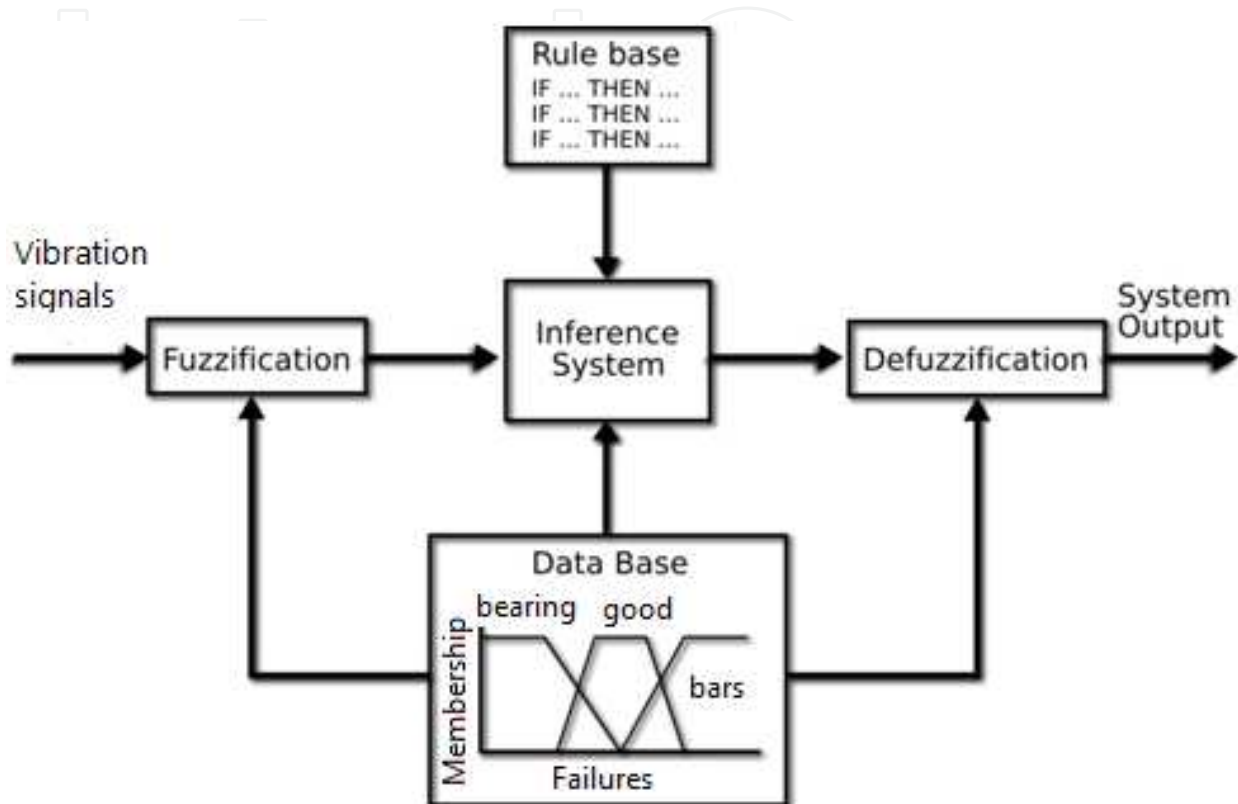

Fig. 2. Fuzzy inference system structure

- i. A rule base containing a number of fuzzy *if-then* rules.
- ii. A database which defines the membership functions of the fuzzy sets used in the fuzzy rules.
- iii. A decision-making unit which performs the inference operations on the rules.
- iv. A fuzzification interface which transforms the crisp inputs into degrees of match with linguistic values.
- v. A defuzzification interface which transforms the fuzzy results of the inference into a crisp output.

Frequently, the rule base and the database (e.g. vibrations data in different conditions) are jointly referred to as the *knowledge base*.

The steps of fuzzy logic (inference operations upon fuzzy *if-then* rules) performed by fuzzy inference systems for machine's diagnoses are shown in Figure 3.

Several types of fuzzy logic have been proposed in the open research. Depending on the types of fuzzy reasoning and fuzzy *if-then* rules employed, most fuzzy inference strategies may be classified as follows (Jang, 1993).

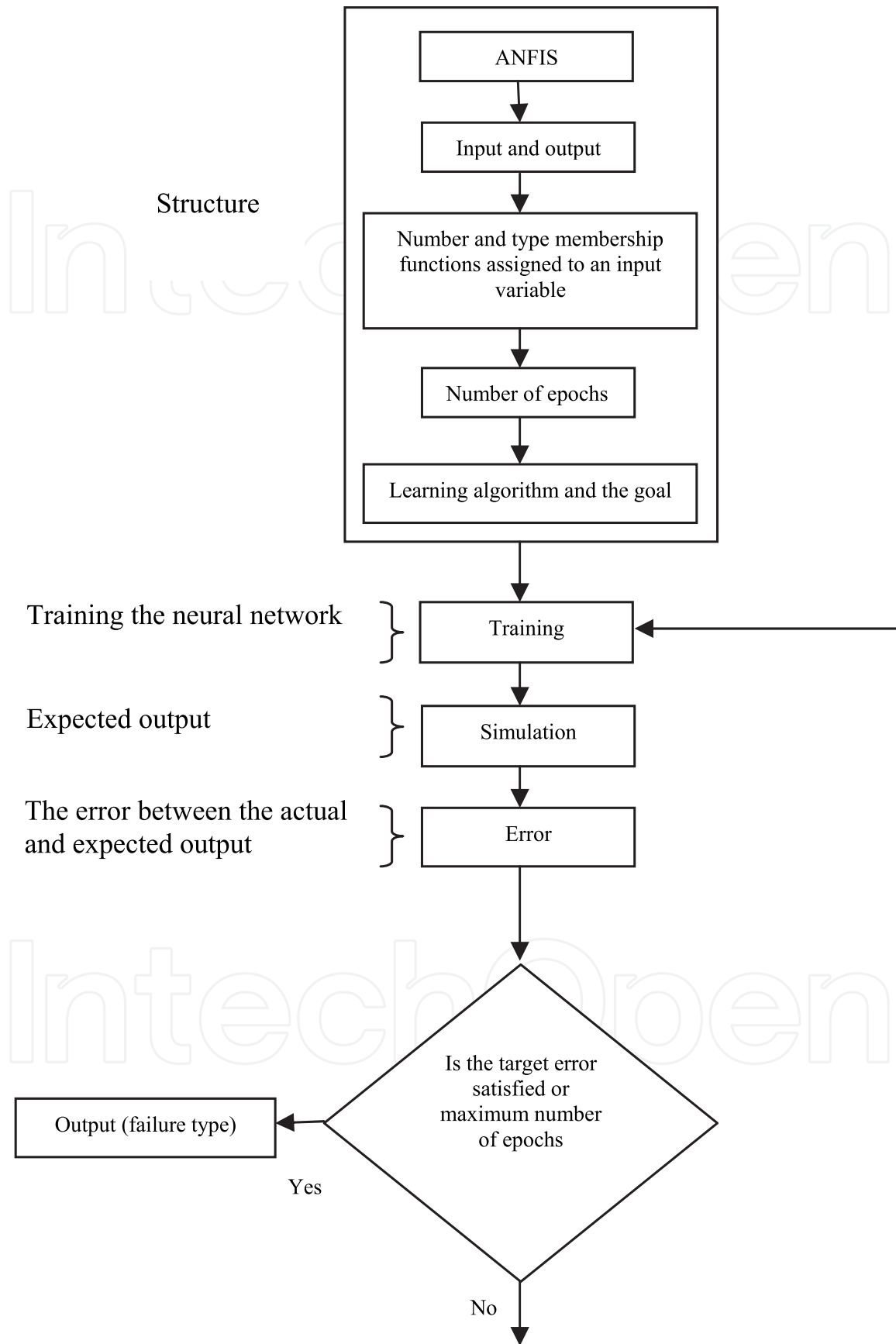

Fig. 3. Flowchart of the followed inference strategy

Type 1: The overall output is the weighted average of each rule's crisp output induced by the rule's firing strength and output membership functions. The output membership functions used in this scheme must be monotonic functions (Lee, 1990).

Type 2: The overall fuzzy output is derived by applying maximization operation to the qualified fuzzy outputs, each of which is equal to the minimum of firing strength and the output membership function of each rule. Various schemes have been proposed to choose the final crisp output based on the overall fuzzy output; some of them are the centroid of area, mean of maxima, maximum criterion, etc., (Lee, 1990).

Type 3: In (Lee, 1990, as cited in Takagi & Sugeno, 1985) fuzzy *if-then* rules are used. The output of each rule is a linear combination of input variables plus a constant term, and the final output is the weighted average of each rule's output.

2.4 ANFIS basics

In ANFIS, the adaptive network structure is a multilayer feed-forward network where each node performs a particular function (node function) on incoming signals as well as a set of parameters pertaining to this node. The node functions may vary from node to node, and the choice of each node function depends on the overall input-output function that the adaptive network is required to carry out. Notice that links in an adaptive network indicate the flow direction of signals between nodes; no weights are associated with the links.

Functionally, there are almost no constraints on the node functions of an adaptive network, except piecewise differentiability. Structurally, the only restriction of the network configuration is that it should be of feed-forward type. Due to these minimal restrictions, the adaptive network's applications are immediate and immense in various areas. (Jang, 1993) proposed a class of adaptive networks that are functionally equivalent to fuzzy inference systems. The proposed architecture is referred to as ANFIS, standing for adaptive-network-based fuzzy inference system.

An adaptive network is a structured network composed by nodes and directional links, which connect nodes, Fig. 4. All or some nodes are adaptive. It means that results depend on nodes' parameters, and the learning rules specify how these parameters must change in order to minimize an error. The adaptive network is constituted by a multilayer feedback network, where each node performs a particular task (node function) on the incoming signals, as well as a set of node parameters.

The ANFIS can be trained by a hybrid learning algorithm (Jang, 1993; Jang & Sun, 1996; Jang & Gulley, 1995). It uses a two-pass learning cycle. In the forward pass, the algorithm uses the least-squares method to identify the consequent parameters on the layer 4. In the backward pass, the errors are propagated backward and the premise parameters are updated by gradient descent.

ANFIS is a tradeoff between neural and fuzzy systems, providing: (i) smoothness, due to the Fuzzy interpolation; (ii) adaptability, due to the neural net backpropagation; (iii) ANFIS however has a strong computational complexity restriction.

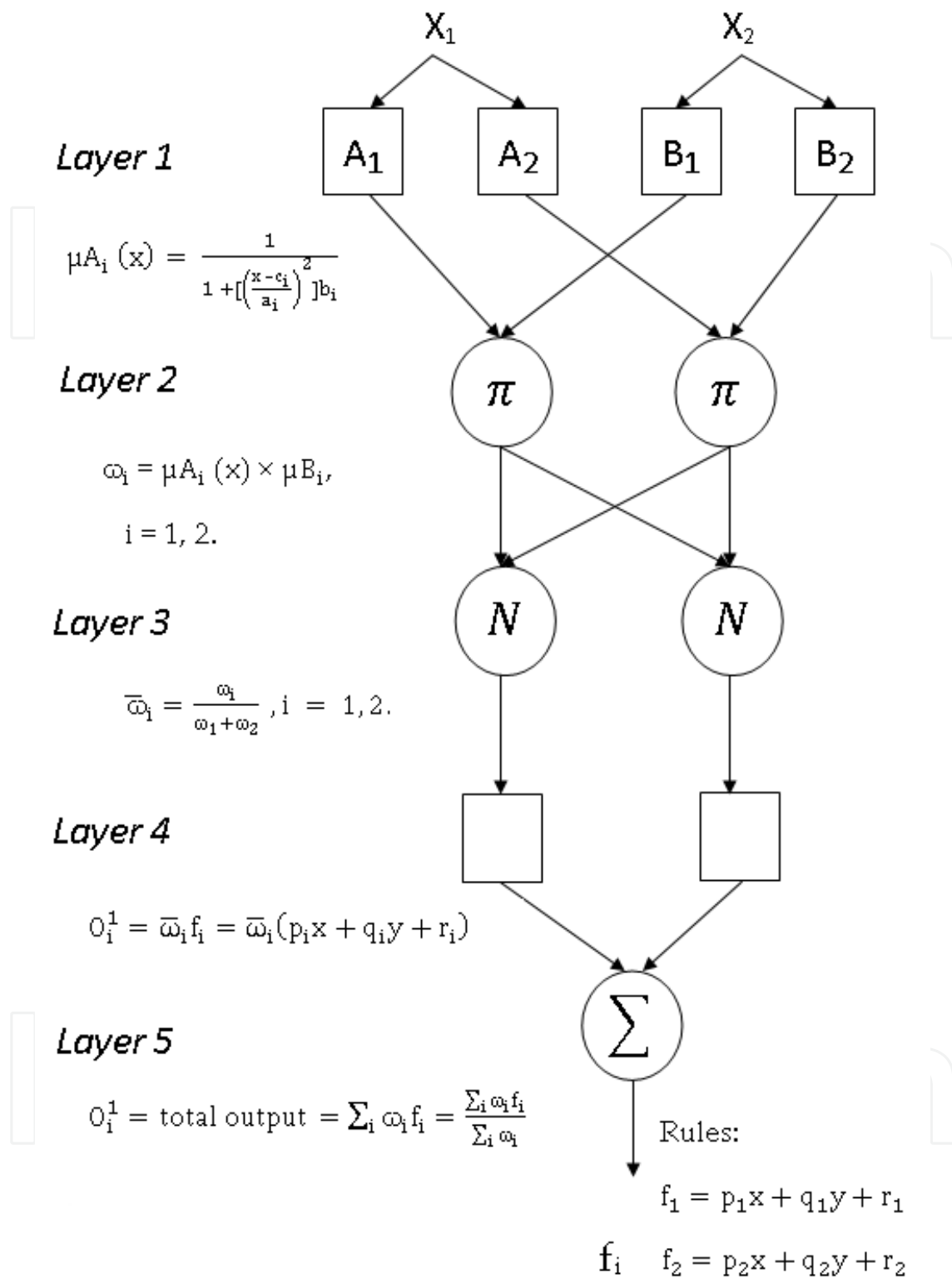

Fig. 4. Set of calculations in ANFIS

where:

x_i is the input into node i

A_i is the linguistic label

μ_{A_i} is the A_i 's membership function.

$\{a_i, b_i, c_i\}$ is the set of parameters. Modifying these parameters, the shape of the bell functions change, so that exhibit different forms of membership functions for the linguistic label A_i .

ω is the level-3 output.

$\{p_i, q_i, r_i\}$: is the set of parameters, which at this level may be referred to as consequent parameters.

2.5 Vibration analysis by wavelets

The raw material to make any inference about the machinery's condition is the information captured from vibration signals. The proposition is to utilize the vibration's raw signals to infer about the engine's state. A structured analysis may characterize the nature of the vibration, figure 5.

Wavelets transformation is the disintegration of a signal which becomes represented by means of function approximations and differences, which are divided by levels, figure 6, each of which have different resolutions, being equivalent to filtering the signal through a filter bank. The initial filtering takes the signal and passes it through the first bank, resulting in two signals with different frequency bands (high and low bands).

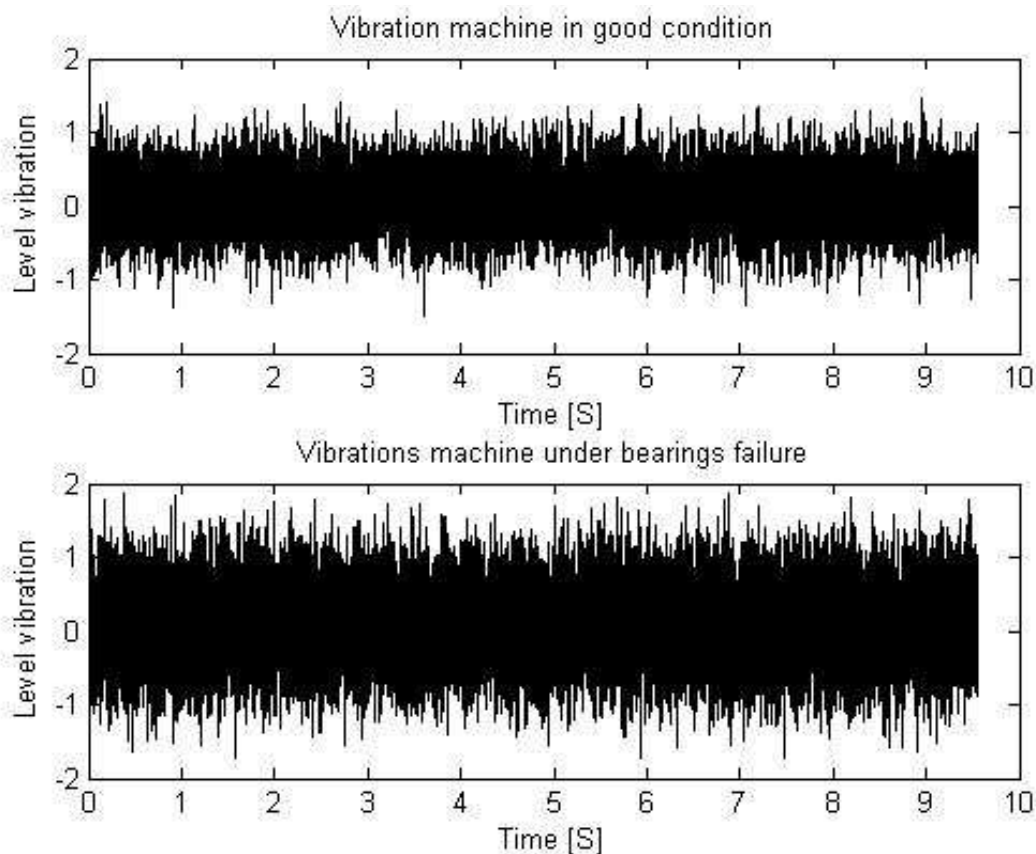

Fig. 5. Vibration patterns under failure and normal conditions.

The time-frequency resolution of the transformed wavelet satisfies the Nyquist sampling theorem. That is, the maximum frequency component embedded into a signal can be uniquely determined if the signal is sampled at a frequency F_s , which exceeds or equals the double of the signal's maximum frequency F_{max} . At the limit, if $F_s = 2F_{max}$ then:

$$F_{max} = F_s/2 = 1/(2T) \quad (1)$$

where T is the sampling interval. That is, if the frequency F_{max} of the original signal is divided into two sub-frequency bands, where $p/2$ is the highest frequency band, it leads to $F_s = p$ and $T = 1/p$. To clarify the concept, consider the scheme of underlying filters, which perform the discrete wavelet transformation. Under this concept, for each filtering level the incoming signal is split into low and high frequencies. Since the output from low frequencies is subjected to additional filters, the resolution increases as the spectrum is divided again into two sub-bands.

The resolution time is reduced because of the decimation that takes place. The above-mentioned strategy has been employed to make an inference about the engine's state, using vibration measurements as input

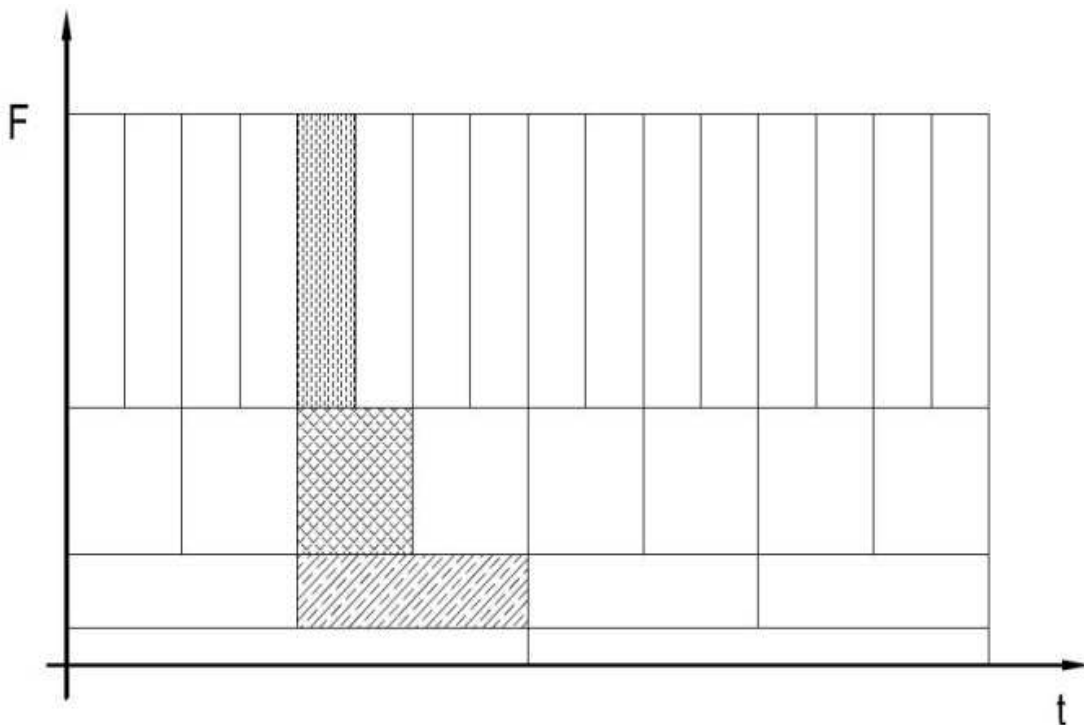
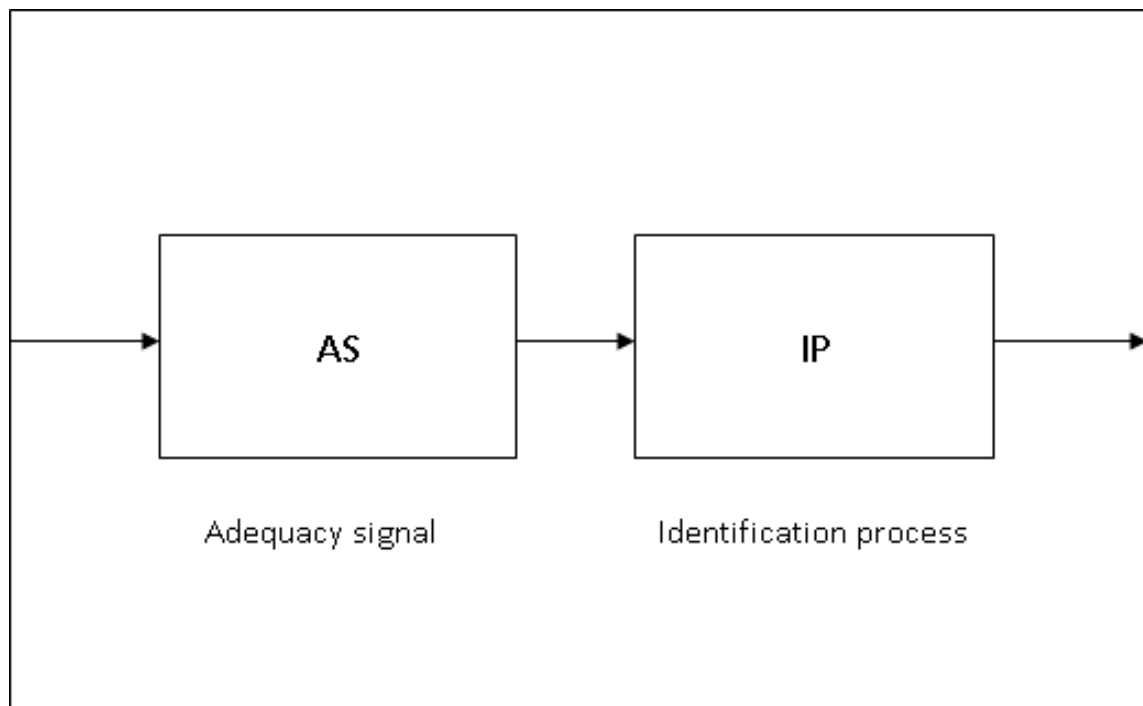

Fig. 6. Time-Frequency resolution of a transformed wavelet

3. Proposition

It is important to emphasize that the main aim of this chapter is the inference system, and to present the structured method for signal processing. The necessary requirements to establish the machine's operating conditions are presented below, and consist in a hybrid method decomposed in two phases. Phase I is the adequacy of the signal, while phase II is the inference or identification procedure, figure 7. Both phases I and II may be represented by two functional blocks that perform different treatments to the vibration signals.

The process of the adequacy signal is necessary because the exclusive ANFIS application to minimally invasive faults does not generate a successful inference process



Inferences system

Fig. 7. Stages of the inference system

In this application, measurements are taken by a 12-bit LIS3L02ASA vibration sensor (accelerometer based on MEMS - Microelectromechanical system), which provides measurement of displacement in three axes. Additionally, to reduce the noise/signal proportion, filtering is added.

Thus, the triaxial accelerometer, is one of the most important parts of the instrumentation system, being located in the engine body, which measures vibrations based on three axes (x, y, z) using a sampling rate of 1500Hz. The ADS7841 is a converter equipped with serial synchronous communication interface with 200KHz conversion rate. After the digitalized data is sent via the RS232 card to capture, the system data acquisition uses a MAX3243 circuit.

The sensor provides vibration measurements in three axes. In this research, it was noticed that the perpendicular axes to the axis of rotation have more useful information to identify a failure occurrence. Thus, in order to optimize the computational load, data from the x -axis were used.

4. Case study

The machine used in this study is a 1 HP induction motor, where the load is represented by an alternator coupled to the motor through a band. The alternator feeds a bank of resistors, Fig. 8. Vibration measurements of machines in good condition and under fault conditions are captured and processed in ANFIS to simulate an inference process to identify the occurrence of a specific failure.

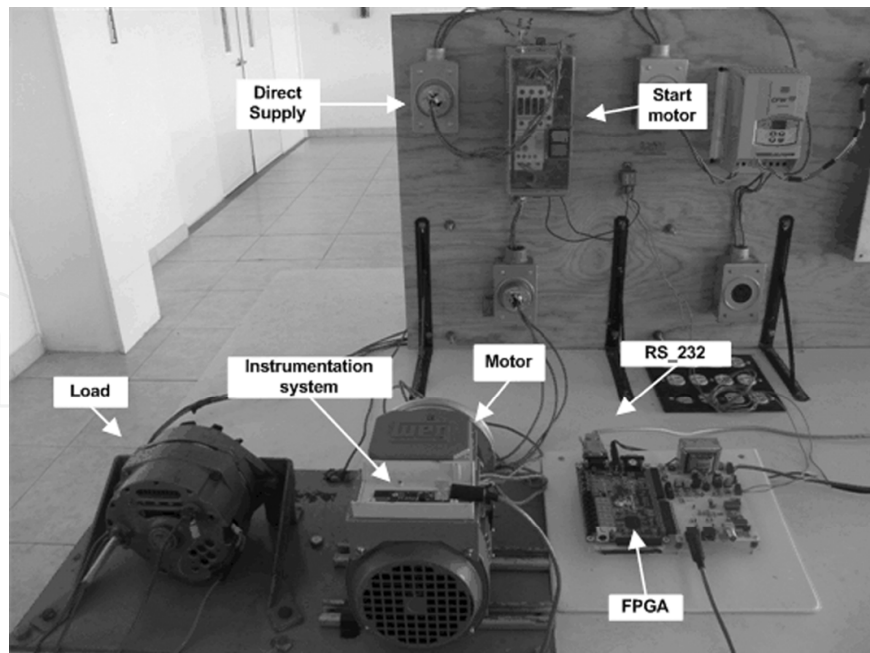

Fig. 8. Induction motor's arrangement

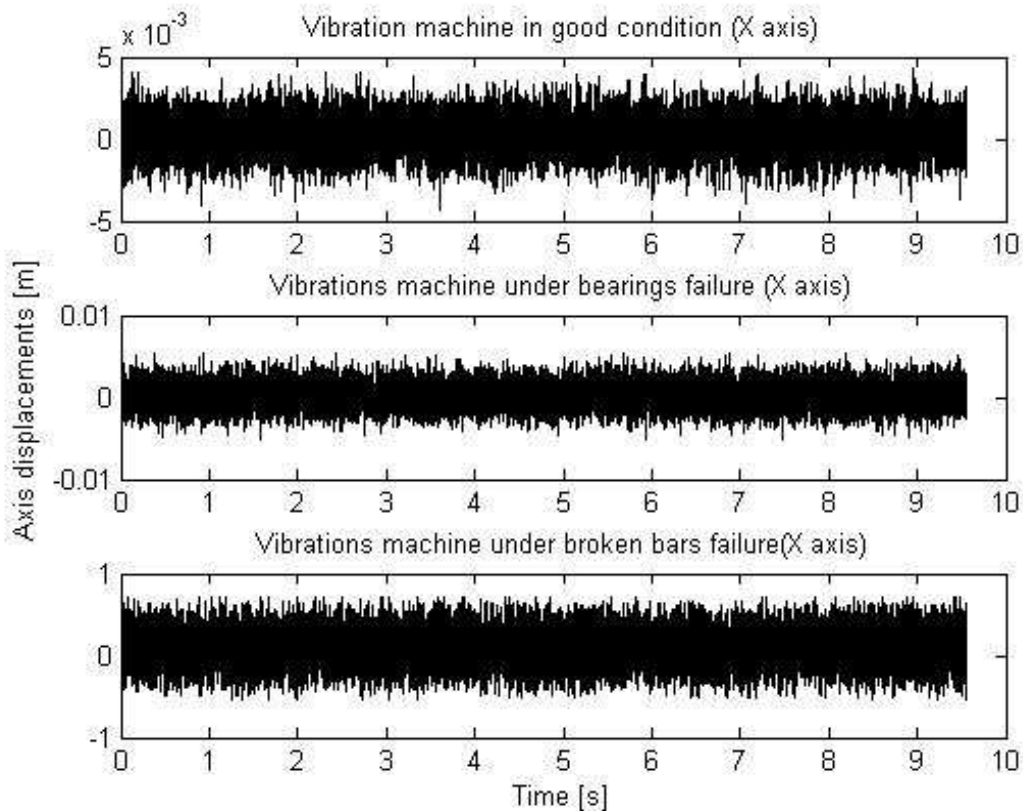

Fig. 9. Vibrations under different conditions

The proposed hybrid method aims to identify the fault states in rotating machines, distinguishing the smooth operation from failure conditions by measuring vibration signals. Vibration measurements have been monitored in three axes: x, y, and z under the following operating conditions:

1. A motor in good condition
2. A motor with bearing fault
3. A motor with broken bars

In the case of bearing failure, there is a minimally invasive phenomenon in the machine's vibration, contrary to a broken bars failure, which gives rise to notorious vibration, Fig 9. The preliminary coarse filtering process is performed by the assembled sensor.

Likewise, at a first glance, the vibrations in the axial direction are more noticeable. Thus, their measurements are employed in the following analysis.

5. Results and discussion

As above mentioned, some minor failures such as bearing failures are not distinguishable by exclusive use of ANFIS, figure 10. This is why the use of wavelets provides an effective tool for the identification of different types of failures in electric machines.

The results presented in the following are attained through simulations using real data, when the induction motor is under normal operating conditions and failure.

Phase I:

To exemplify the proposed strategy, the following results are obtained by using the x-axis measurement only. Firstly, the wavelet decomposition requires that n levels be selected, so that the inference process has sufficient information to identify the faulted condition. That is, the quantity of levels is proportional to the filtering quality. In this application, due to the good performance obtained when a correlation test to verify the data stability is carried out, $n = 2$ will be used.

That is, the number of levels affects the number of sets resulting from the wavelet decomposition, leading to four functions: two for high frequency, and two for low frequency. Figure 11 shows the wavelet decomposition corresponding to the motor in good condition.

In this study the Meyer wavelet family is used (which properties are symmetry, orthogonality, biorthogonality) and the Shannon Entropy decomposition was used (Zadeh, 1965; Proakis, 2001; Anderson, 1984; Oppenheim & Schaffer 2009)

Phase II:

Once the wavelet decomposition is evaluated, data must be structured and handled by the software, with the proper procedure.

Training data: the historical data set representing each particular state of the machine requires the corresponding wavelet decomposition.

Checking data: data used to test and infer. From a practical standpoint, they are the vibration measurements under the studied condition.

Tags: correspond to that feature that allows the user to differentiate one condition from another. For the studied case, numerical levels will be used for each engine's state.

Applying the proposed method to failures on bearings and broken bars, Figures 12-13 depict a typical result. It is noteworthy that the checking and training data are perfectly

differentiable through level changes observed in the data. Labels are selected by the user to have a reference, which is the state that the machine is undergoing.

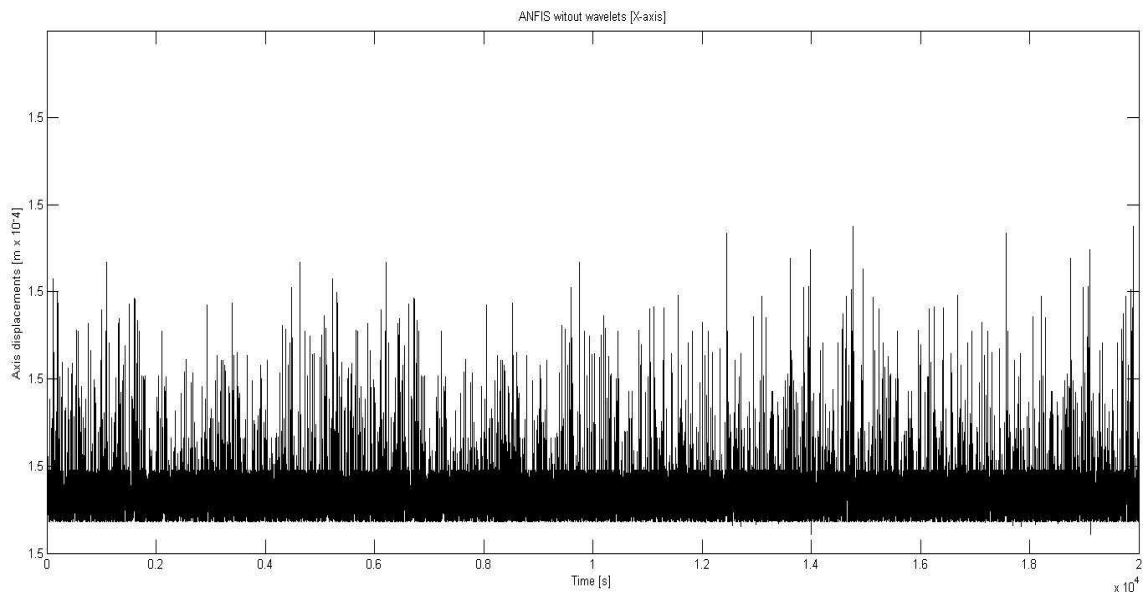

Fig. 10. Bearing failure ANFIS without wavelet decomposition

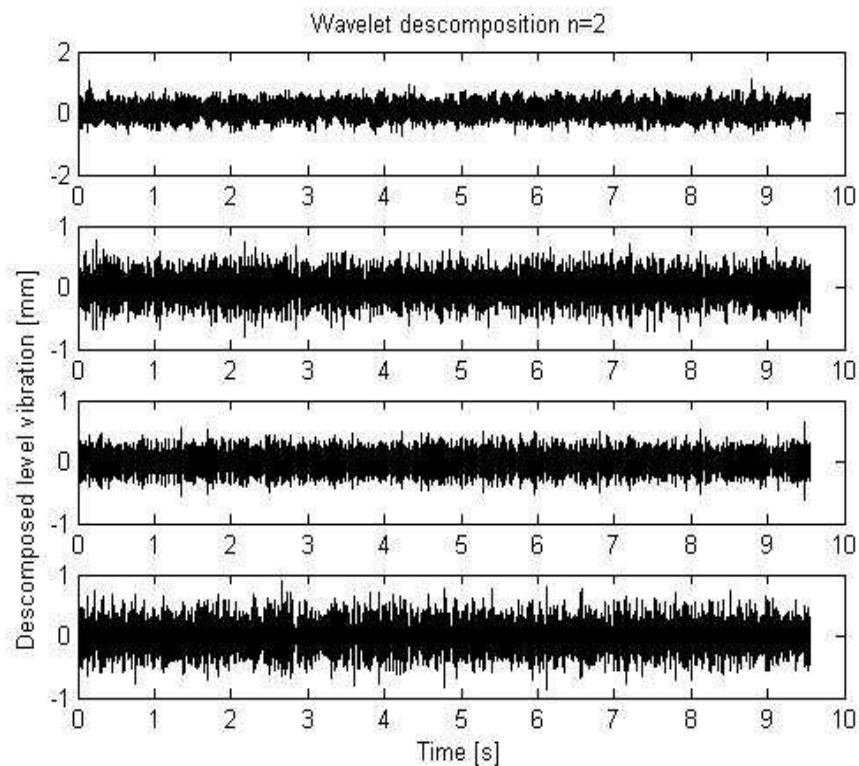

Fig. 11. A machine in good condition: wavelet decomposition, $n=2$.

Additionally, Figures 14-15 display the Root Mean Squared Error (RMSE) between the checking and training curves, for both failures, where the RMSE is a quadratic scoring rule, which measures the average magnitude of the error. Expressing the expression in words, the difference between the forecasted and the corresponding observed values are each squared

and then averaged over the sample. Finally, the square root of the average is calculated, since the errors are squared before they are averaged.

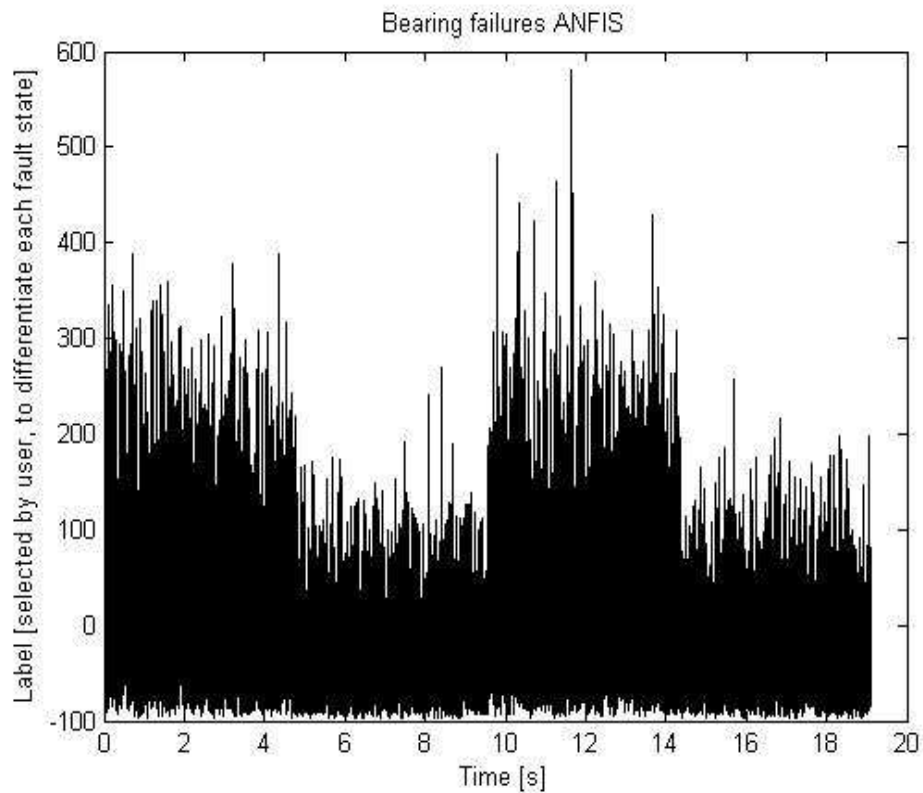

Fig. 12. Bearing failure

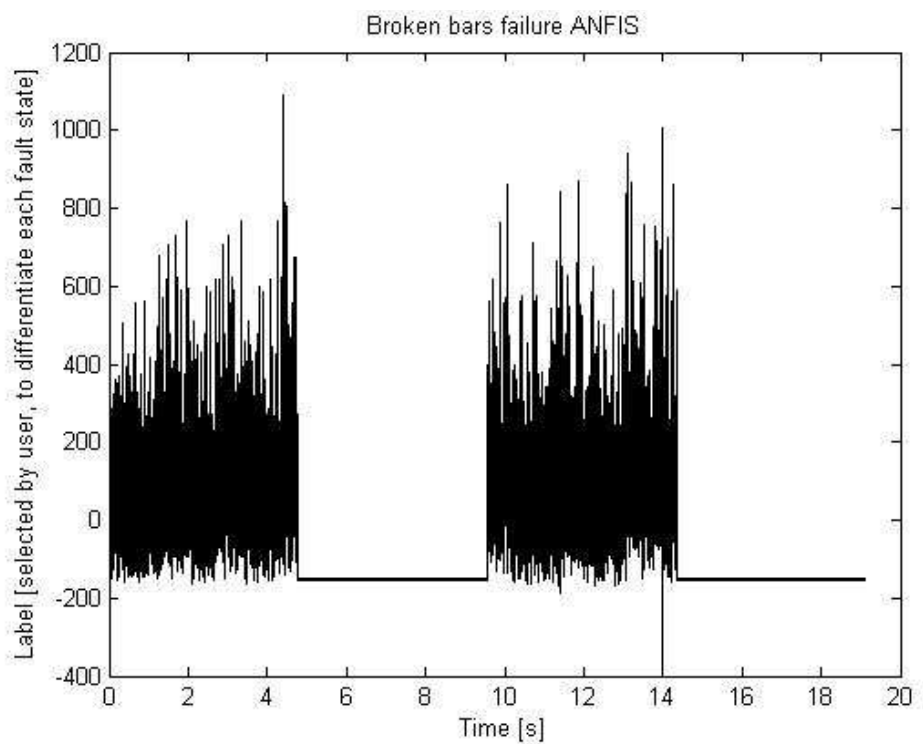

Fig. 13. Broken bars failure

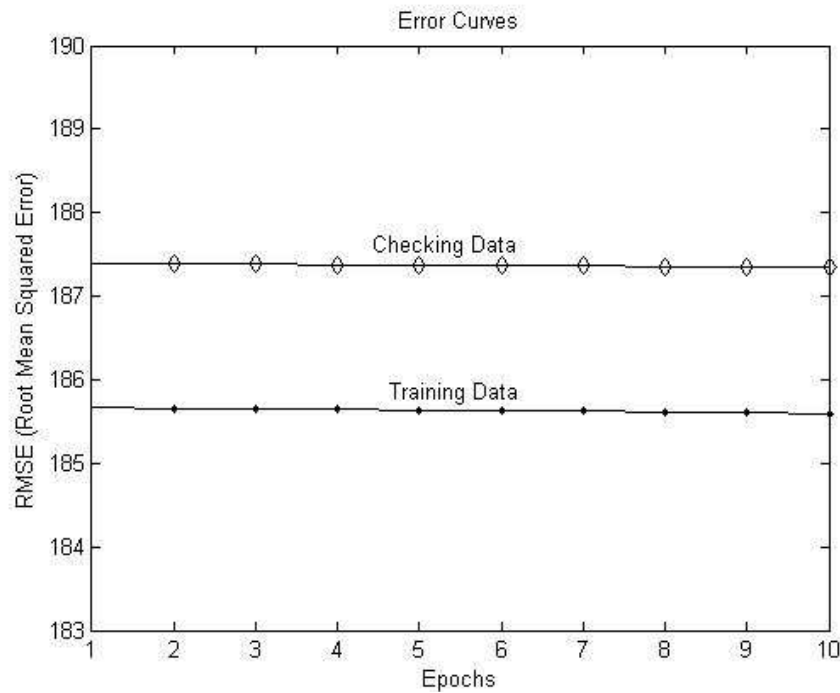

Fig. 14. Error between checking and training curves for bearing failures

It is important to clarify that, for the training-optimization process, ANFIS uses a combination of the method by least squares and gradient descent.

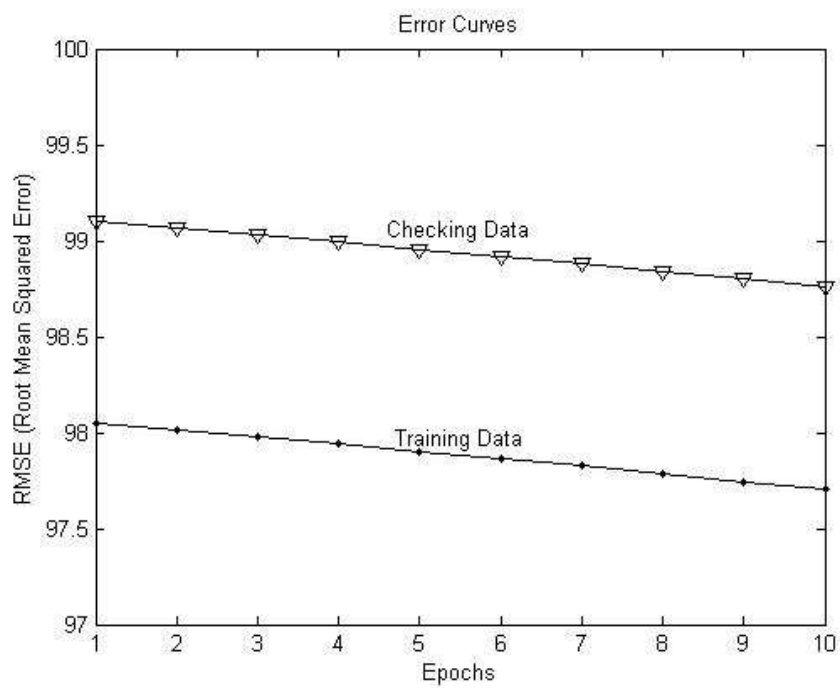

Fig. 15. Error between checking and training curves for broken bars

In Figures 16-17 the mean for both failures are exhibited, which have been calculated as an average data set for each level, where it is clear that inference process has been successful, because the labels are clearly differentiable, where positive and negative values are the

result of a previous selection of tags formed by numerical extremes to differentiate the states where the motor is.

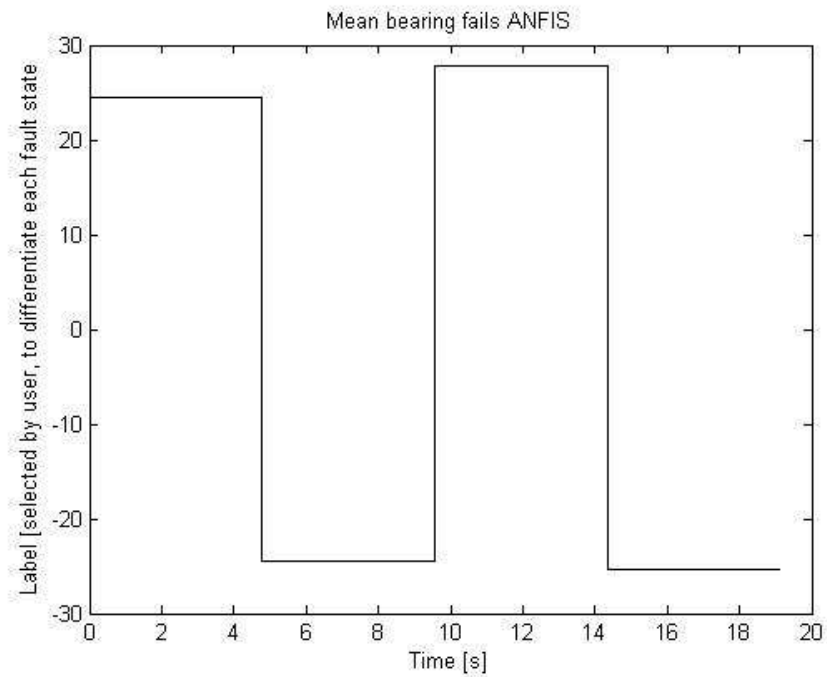

Fig. 16. Mean under bearing failure

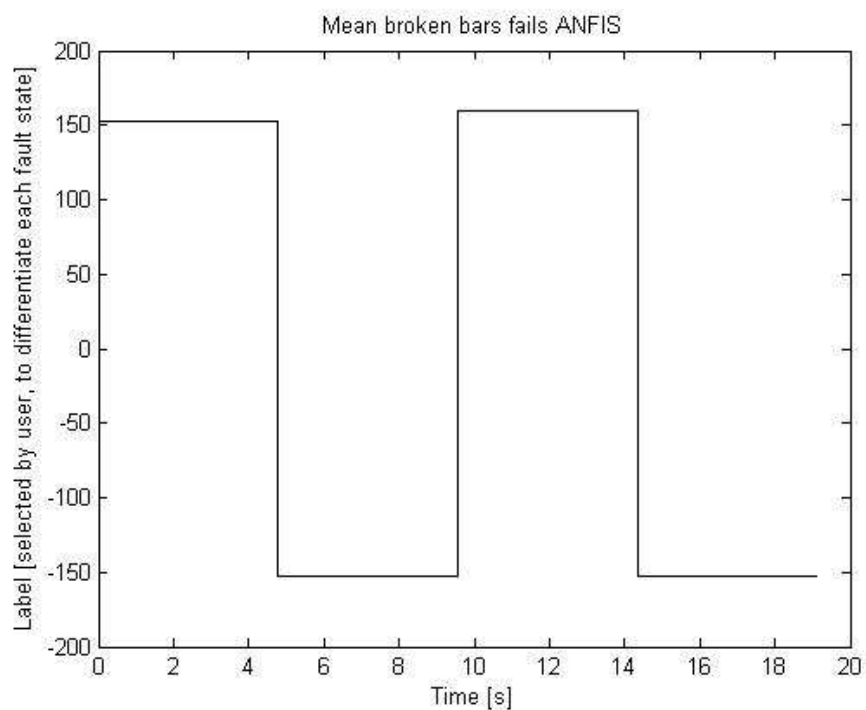

Fig. 17. Mean under broken bars failure

6. Conclusions

The study of vibration in rotating electrical machines through ANFIS requires the use of signal conditioning tools, which are introduced through the training and test arrays. Special care should be taken with some overlapping modes, especially in those failures that, due to their nature, do not generate large perturbations in oscillations, but represent an imminent risk to the engine's life.

The failures considered in the electrical machines studied, reflected changes in the three axes x , y and z . However, they are most noticeable in those that are axial to the axis of rotation, allowing the detection of failures through the analysis on a single axis, instead opening the way for the use of less sophisticated sensors, reducing the implementation costs.

In the inference process it is quite attractive to use pragmatic strategies to handle large amount of measured information, and able to identify the machinery's operating condition.

The errors between the check and learning curves for the two types of studied failures are satisfactory for identification purposes in both cases. Thus, ANFIS has been successfully applied to distinguish between such failures.

7. Acknowledgment

Our gratitude to Universidad de Guanajuato for providing data for this research.

8. References

- Anderson, T. (1984). *An introduction to Multivariate Statistical Analysis*, Wiley, ISBN 978-0471889878, Stanford, California, United States of America
- Blodt, M.; Granjon, P.; Raison, B.; & Rostaing, G. (2008) Models for Bearing Damage Detection in Induction Motors Using Stator Current Monitoring. *IEEE Transactions on Industrial Electronics*, Vol. 55, No. 4, pp. 1813-1822. ISSN 0278-0046
- Blodt, M.; Regnier, J.; & Faucher, J. (2009). Distinguishing Load Torque Oscillations and Eccentricity Faults in Induction Motors Using Stator Current Wigner Distributions. *IEEE Transactions on Industry Applications*, Vol. 45, No. 6. pp. 1991-2000, ISBN: 1-4244-0364-2
- Bonissone, P.; Badami, V.; Chiang, K.; Khedkar, P.; Marcelle, K. & Schutten, M. (1995). Industrial applications of fuzzy logic at General Electric. *Proceedings of the IEEE*, Vol. 83, No.3, pp 450-465, ISSN 0018-9219
- Cusido, J.; Romeral, L.; Ortega, J.; Rosro, J., & Espinosa, A. (2008). Fault Detection in Induction Machines Using Power Spectral Density in Wavelet Decomposition. *IEEE Transactions on Industrial Electronics*, Vol. 55, No. 2, pp. 633-643, ISSN 0278-0046
- Jang, J. (1993). ANFIS: adaptive-network-based fuzzy inference system. *IEEE Transaction Systems, Man, Cybernetics*, Vol. 23, No. 3, pp. 665-685, ISSN 018-9472
- Jang, J. & Sun, C. (1995). Neuro-fuzzy modeling and control. *Proceedings of the IEEE*, Vol. 83, No. 3, pp 378-406. ISSN 0018-9219
- Jang, J. & Gulley, N. (1995). *The Fuzzy Logic Toolbox for use with MATLAB*, The MathWorks, Inc., Natick, Massachusetts

- Lee, C. (1990). Fuzzy logic in control systems: fuzzy logic controller. *Systems, Man and Cybernetics, IEEE Transactions on*, Vol.20, No. 2, pp. 404 - 418, ISSN 0018-9472
- Michie, D.; Spiegelhart, D. & Taylor, C. (1994) *Machine Learning, Neural and Statistical Classification*, Ellis Horwood, ISBN 978-8188689736, New York
- Omar, M.; Zaidan, M. ; & Tokhi, M. (2010). Modelling of a Flexible Manoeuvring System Using ANFIS Techniques. *Computer Modelling and Simulation (UKSim) 12th International Conference on*, pp. 33-38, ISBN 978-1-4244-6614-6
- Oppenheim, A.; Schafer, R. & Padgett, W. (2009). *Discrete-Time Signal Processing*, Prentice Hall, ISBN 978-0131988422
- Proakis, J. (2001). *Digital Communications*. McGraw-Hill Science and Engineering, ISBN 978-0072321111. United States of America
- Riera, M.; Antonio, J.; Roger, J.; & Palomares, M. (2008). The Use of the Wavelet Approximation Signal as a Tool for the Diagnosis of Rotor Bar Failures. *IEEE Transactions on Industry Applications*, Vol. 44, No. 3, ISSN 0093-9994
- Tagaki, T. & Sugeno M. (1985). Fuzzy identification of systems and its applications to modeling and control, *IEEE Transaction Systems., Man, Cybernetics.*, Vol. 15, pp. 116-132, ISSN 018-9472
- Taylor, J. (2003). *The Vibration Analysis Handbook*. Vibration Consultants. ISBN 978-0964051720
- Zadeh, L. (1965). Fuzzy sets. *Information and Control Elsevier Science*, Vol. 8, pp. 338-353, ISSN: 0019-9958

IntechOpen



Fuzzy Inference System - Theory and Applications

Edited by Dr. Mohammad Fazle Azeem

ISBN 978-953-51-0525-1

Hard cover, 504 pages

Publisher InTech

Published online 09, May, 2012

Published in print edition May, 2012

This book is an attempt to accumulate the researches on diverse inter disciplinary field of engineering and management using Fuzzy Inference System (FIS). The book is organized in seven sections with twenty two chapters, covering a wide range of applications. Section I, caters theoretical aspects of FIS in chapter one. Section II, dealing with FIS applications to management related problems and consisting three chapters. Section III, accumulates six chapters to commemorate FIS application to mechanical and industrial engineering problems. Section IV, elaborates FIS application to image processing and cognition problems encompassing four chapters. Section V, describes FIS application to various power system engineering problem in three chapters. Section VI highlights the FIS application to system modeling and control problems and constitutes three chapters. Section VII accommodates two chapters and presents FIS application to civil engineering problem.

How to reference

In order to correctly reference this scholarly work, feel free to copy and paste the following:

Fredy Sanz, Juan Ramírez and Rosa Correa (2012). Fuzzy Inference Systems Applied to the Analysis of Vibrations in Electrical Machines, Fuzzy Inference System - Theory and Applications, Dr. Mohammad Fazle Azeem (Ed.), ISBN: 978-953-51-0525-1, InTech, Available from: <http://www.intechopen.com/books/fuzzy-inference-system-theory-and-applications/fuzzy-inference-systems-applied-to-the-analysis-of-vibrations-in-electric-machines>

INTECH
open science | open minds

InTech Europe

University Campus STeP Ri
Slavka Krautzeka 83/A
51000 Rijeka, Croatia
Phone: +385 (51) 770 447
Fax: +385 (51) 686 166
www.intechopen.com

InTech China

Unit 405, Office Block, Hotel Equatorial Shanghai
No.65, Yan An Road (West), Shanghai, 200040, China
中国上海市延安西路65号上海国际贵都大饭店办公楼405单元
Phone: +86-21-62489820
Fax: +86-21-62489821

© 2012 The Author(s). Licensee IntechOpen. This is an open access article distributed under the terms of the [Creative Commons Attribution 3.0 License](#), which permits unrestricted use, distribution, and reproduction in any medium, provided the original work is properly cited.

IntechOpen

IntechOpen