

We are IntechOpen, the world's leading publisher of Open Access books Built by scientists, for scientists

4,800

Open access books available

122,000

International authors and editors

135M

Downloads

Our authors are among the

154

Countries delivered to

TOP 1%

most cited scientists

12.2%

Contributors from top 500 universities



WEB OF SCIENCE™

Selection of our books indexed in the Book Citation Index
in Web of Science™ Core Collection (BKCI)

Interested in publishing with us?
Contact book.department@intechopen.com

Numbers displayed above are based on latest data collected.

For more information visit www.intechopen.com



Migrating from Manual to Automated Assembly of a Product Family: Procedural Guidelines and a Case Study

Michael A. Saliba* and Anthony Caruana

*Department of Industrial and Manufacturing Engineering, University of Malta
Malta*

1. Introduction

A challenge that is often faced by product manufacturers is that of migration from a manual to an automated production system. The need to embark on this migration may develop from a number of different scenarios. Typical triggers for the automation of a manual production process include a need to increase competitiveness (by reducing labour costs and increasing labour productivity), a need to meet higher quality demands from the customer, an increased awareness of health and safety issues leading to the need to move human workers away from hazardous tasks, and a need to improve production efficiency parameters (e.g. reduce manufacturing lead time, improve production capacity, improve production flexibility and agility). The general strategic and/or technical aspects pertaining to the implementation of automation have been widely addressed in the literature (e.g. Asfahl, 1992; Chan & Abhary, 1996; Groover, 2001; Säfsten et al., 2007). In this work the focus is on the compilation and application of a number of standard design tools and of production system evaluation tools to facilitate and support the migration to an automated production system, in a scenario that involves a certain degree of product variety. The results are presented in the form of a set of recommended procedural guidelines for the development of a conceptual solution to the migration process, and the implementation of the guidelines in a real industrial case study.

Specifically, this work addresses the situation where a manufacturer needs to investigate a potential manufacturing system migration for the assembly of a part family of products, where no or minimal product design changes are allowed. A list of procedural guidelines is proposed, in order to aid the manufacturer in analyzing the requirements for the transition, and in carrying out a conceptual design for a suitable automated manufacturing system. The guidelines are applied in the context of the industrial case study, where it is required to investigate and develop a migration plan for the assembly of three related product part families.

The case study involves a relatively large manufacturing plant (about 700 employees), that produces electromechanical switch assemblies for the automobile industry. The trigger for

* Corresponding Author

the migration process is a significant increase in projected order volumes over a four year period, thus necessitating an increase in production capacity, as well as providing a good opportunity to obtain substantial return on investment following the implementation of advanced manufacturing technologies. The three part families under consideration are referred to as the “single gang” switches consisting of 20 variants, the “old three gang” switches consisting of 11 variants, and the “new three gang” switches consisting of 9 variants. A representative member of each of these families is shown in the illustration in Figure 1. Switch assembly is currently carried out in a mainly manual manner, with the aid of pneumatic presses to provide the required clipping forces. The projected production volumes for the current year (Year 1) and for the subsequent years are summarized in Table 1.

The academic goals of this research are (i) to compile a set of guidelines for migration in a scenario of this type, and to apply the guidelines to this case study; (ii) to perform a study on assembly related similarities of the product families and to take advantage of these similarities in the automation process; (iii) to interpret the analytical results obtained from the feasibility analysis, so as to define the most suitable assembly line; and (iv) to utilize analytical tools in order to define the best possible concept at all stages of the automation. From an industrial perspective, the goals are (i) to perform a cost reduction exercise on the current assembly processes; (ii) to perform a feasibility analysis of the developed concepts with respect to a number of considerations such as the assembly line balancing, cycle time reduction, production capacity and maintenance requirements; and (iii) to plan the integration of ergonomic principles in all workstations and also develop and implement safety guidelines in the process development.

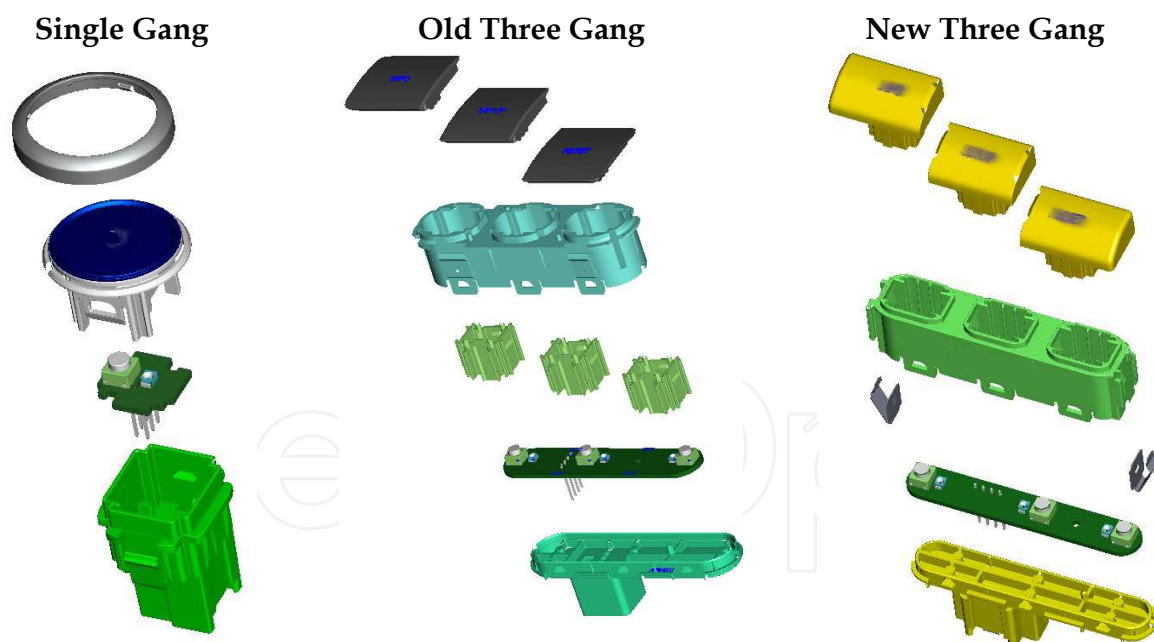

Fig. 1. An exploded view of a representative member of each product family

| | Year 1 | Year 2 | Year 3 | Year 4 |
|----------------------|-----------|---------|-----------|-----------|
| Single gang switches | 136,000 | 935,000 | 1,432,600 | 1,552,600 |
| Old 3 gang switches | 1,098,000 | 816,000 | 816,000 | 816,000 |
| New 3 gang switches | 0 | 150,000 | 865,000 | 1,495,000 |

Table 1. Projected annual production volumes

2. Literature review

In product manufacture, assembly needs to be given significant importance, since assembly related operations generally amount to 70% of the total product cost (Boothroyd et al., 2001). Therefore rationalisation of the assembly process is essential in order to optimize, mechanize and automate the activities performed, especially for assembly-intensive products. Where a new product is being developed, an *Integrated Product Development* (IPD) approach can be taken, whereby the marketing, design, and manufacture of the product family can be optimized and developed concurrently (Andreasen & Hein, 2000). Where the product family exists and is already in manual production, the options for design modifications may be minimal, and the development of the automated production system rests on effective categorization of the products through analytical methodologies such as group technology (e.g. Hyer & Wemmerlov, 2002), and the effective exploitation of the identified similarities.

Several approaches are found in the literature to address the migration problem. Asfahl (1992) identified five phases in the implementation of automation to a currently manual process: *planning, development, mock-up and test, installation, and production and follow-through*. He further highlighted a number of key activities to be carried out during the planning phase: the isolation of the potential application; the identification of the project objectives; the consideration of the drawbacks; the early planning of safety aspects; the detailed documentation of the current (manual) operation; the selection of fixed versus flexible automation; and the development of a proposed layout for the system. Chan and Abhary (1996) applied an analytic hierarchy process to compare three different potential automation strategies to the existing manual plant in a case study, using a simulation approach and several evaluation criteria. Kapp (1997) introduced the "USA Principle" - *Understand the existing process, Simplify the process, and Automate the process*, originally intended as a guide for the implementation of enterprise resource planning (ERP), but applicable as a straightforward approach to all automation projects. Groover (2001) suggested a three-phase process whereby the individual processing stations are automated first, followed by the integration of the systems through automated handling between stations. Baines (2004) recommended a nine step approach to the manufacturing technology acquisition process: technology profiling; establishment of technology requirements; identification of a technology solution; formation of an outline business case; selection of a technology source (which may include internal development of the technology); demonstration of the technology; confirmation of the business case; implementation of the technology; and post-investment audit. Säfsten et al. (2007) suggested that manufacturing strategy development could be based on function allocation, employing a system design process that allocates various functions to either humans or machines, and optimizing the level of automation in the plant. Winroth and Säfsten (2008) further suggested an automation strategy whereby the bottom-up activities (stemming from the internal need for improvement) and the top-down activities (stemming from the market requirements) are both taken into consideration in the optimization exercise.

Most of the technical literature on the development of automation systems focuses on the process that needs to be automated and/or on the product that needs to be manufactured, but less so on the production system as a product in its own right. Thus, a number of design methods that have become a mainstay in product design are not normally prescribed in a

systematic way to the development of integrated automation systems. Design methods include tools and techniques such as product design specification (PDS), morphological charts, decision matrices, and failure modes and effects analyses (FMEA) (e.g. Dieter & Schmidt, 2009). This is the research gap that has been identified in this work, and the results reported in this chapter attempt to bridge this gap by drawing on these design methodologies, and prescribing them side by side with other conventional developmental steps, in order to optimize the conceptual design process for an automation system, in an environment of variety in the products that need to be manufactured. The contribution of this work is further extended to include a detailed illustration of the step by step application of the procedural guidelines to a complex industrial case study.

3. The procedural guidelines

A systematic approach to the conceptual design of a new, automated manufacturing system when migrating from manual assembly of a product part family, where little or no change in product design is allowed, is presented in Table 2. The proposed list of procedural guidelines and development tools given in the table has been compiled on the general basis of the discussion given in section 2, and the developmental steps are intended to be applied sequentially, for the case of a high production volume environment in the presence of product variety. The guidelines are intended to cover the early technical and feasibility studies. Thus it is pre-assumed that the company has already taken a strategic decision to analyze the selected manual process with a view to implementing automation (if feasible), and the guidelines lead to the end of the conceptual design phase but do not address any part of the embodiment design phase or of the development of test or prototype hardware. In the general literature, it has been estimated that about 75% of the product cost is normally already committed by the end of the conceptual design stage (Ullman, 1997), and in this work the research boundary has been set to address this critical phase of product development. It is emphasized once again that it is the *production equipment* that is being referred to and considered as the “product” in the context of the previous sentence, rather than the objects (products, or product part family) that will be manufactured by the equipment.

In the following section, the use and implementation of the procedural guidelines is illustrated in the context of the industrial case study, for the development of the conceptual design of a new manufacturing system for the assembly of the three families of automotive switches. The results for each step are summarized, presented and discussed.

4. Implementation of the procedural guidelines: A case study

4.1 Analysis of the product family designs

In a manufacturing environment, parts having similar geometric shapes and sizes or similar processing steps may be grouped into part families, in order to facilitate their design and/or their production. This manufacturing philosophy is referred to as *group technology*. Thus, parts within a particular part family will all be uniquely different, however they will have enough similarities to classify them together as one group (e.g. Groover, 2001). In the present case study, the product designs are fixed, and therefore the application of group technology principles is intended to facilitate the production of the parts. Parts classification

systems are normally based either on similarities in design attributes, or on similarities in manufacturing attributes, or on similarities in both design and manufacturing attributes; however other types of similarity may also be used. Hyer and Wemmerlov (2002) identify nine criteria that may be used to classify parts, based on similarities in product type, market, customers, degree of customer contact, volume range, order stream, competitive basis, process type, and/or product characteristics.

| | |
|-----|---|
| 1. | Analyze the current product family design, with a view to understanding clearly all similarities and variations between the members of the family and between their components. |
| 2. | Analyze the current assembly processes and the existing assembly line(s), with a view to understanding the processes, and identifying drawbacks and opportunities for simplification. |
| 3. | Perform a capacity analysis based on the current set-up, with a view to understanding and defining current capabilities and limitations. |
| 4. | Draw up a product design specification (PDS) chart for the new production system, with a view to defining the requirements and wishes for the new system. |
| 5. | Perform a group technology (GT) analysis, with a view to confirming/revising the parts classification in the context of automated manufacture. |
| 6. | Create precedence diagrams for the process, with a view to understanding the various ways in which assembly operations can be carried out. |
| 7. | Set up a morphological chart for the overall operation, with a view to identifying various alternatives for carrying out the various process steps. |
| 8. | Draw up a number of different layouts at the conceptual level, with a view to identifying different alternatives for the assembly. |
| 9. | Perform a provisional analytical study of each of the concepts, based on various criteria such as achievable cycle times, quality, shop floor area, and flexibility. |
| 10. | Draw up a decision matrix to select the most suitable concept. |
| 11. | Carry out a process failure modes and effects analysis (PFMEA), with a view to identifying and addressing failure mechanisms. |
| 12. | Perform a safety analysis, with a view to identifying and addressing production hazards. |
| 13. | Perform an ergonomic analysis, with a view to optimizing the production system with respect to interactions with human workers. |
| 14. | Carry out a new capacity analysis for the new system, with a view to quantifying the achievable capabilities through automation. |
| 15. | Perform a provisional return on investment analysis, with a view to quantifying provisionally the projected savings and break even times upon implementation of the new system. |

Table 2. The procedural guidelines

In this case study, a preliminary analysis based on product design strongly indicated that the parts fell into three natural groupings as shown in Figure 1 above, based on the overall features of their geometries. All of the 20 variants of single gang switches included a socket, a printed circuit board (PCB), and a push button, as shown in Figure 2(a). The PCB included one or more coloured light emitting diodes (LEDs) as required. Some of these variants included one or more of three additional parts: a chrome ring to provide a different aesthetic finish (such as in the switch shown in Figure 2(b)), a light shield for variants that had two different graphics on their front face (to prevent light leakage between graphics), and a jewel

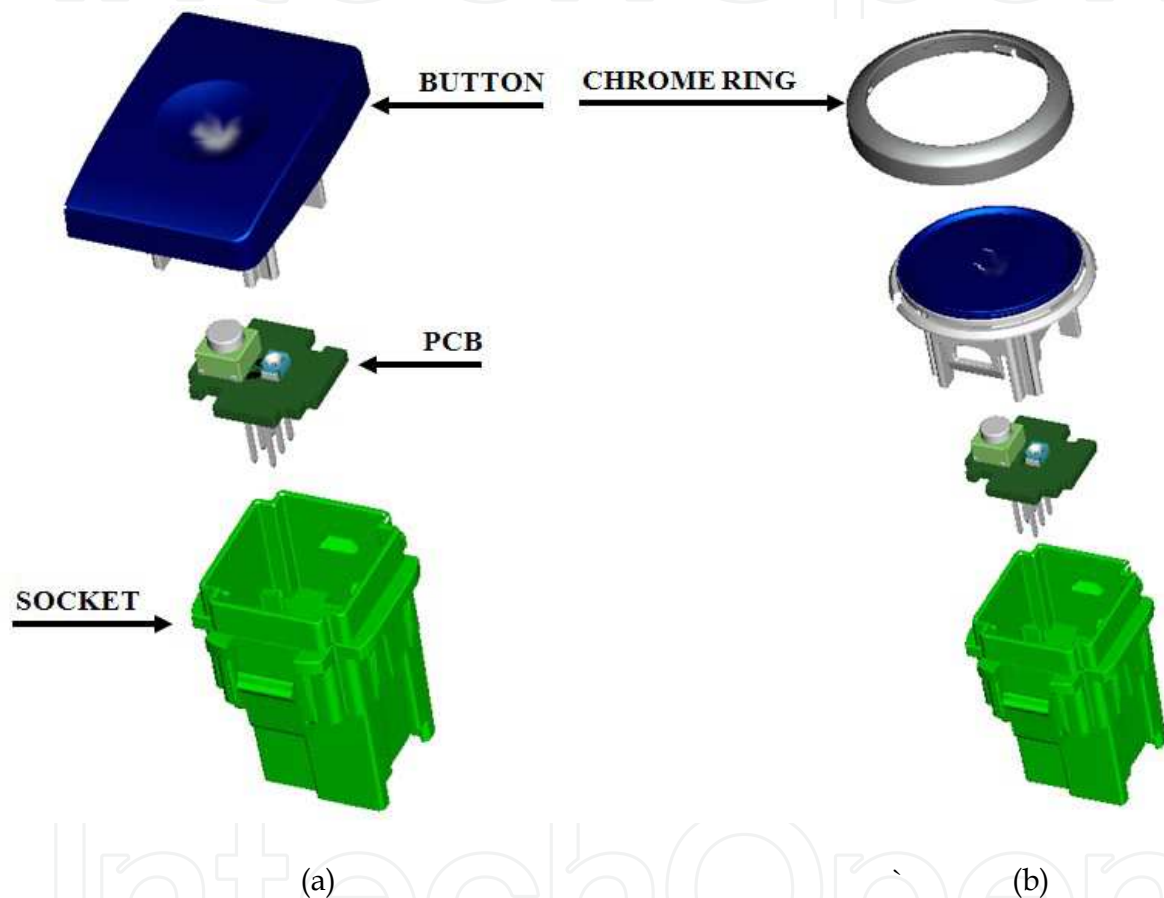

Fig. 2. Single gang switches. (a) a basic variant, (b) variant with a chrome ring

(press fit into the button) to transmit light from the LED to the surface of the button. All of the 11 variants of old three gang switches included a socket, a PCB, one or more sliders, a three unit housing, and three buttons as shown in Figure 3(a). The differences between the variants were defined by the types and combinations of buttons (functional, display, or blank). Functional buttons require a slider, in order to actuate a tact switch on the PCB, and also have a graphic display. Display buttons have only a graphic display (illuminated by an LED on the PCB), and blank buttons have no function or display. The nine variants of new three gang switches have a sleeker design, and use metal clips to attach to the dashboard of the vehicle (see Figure 3(b)).

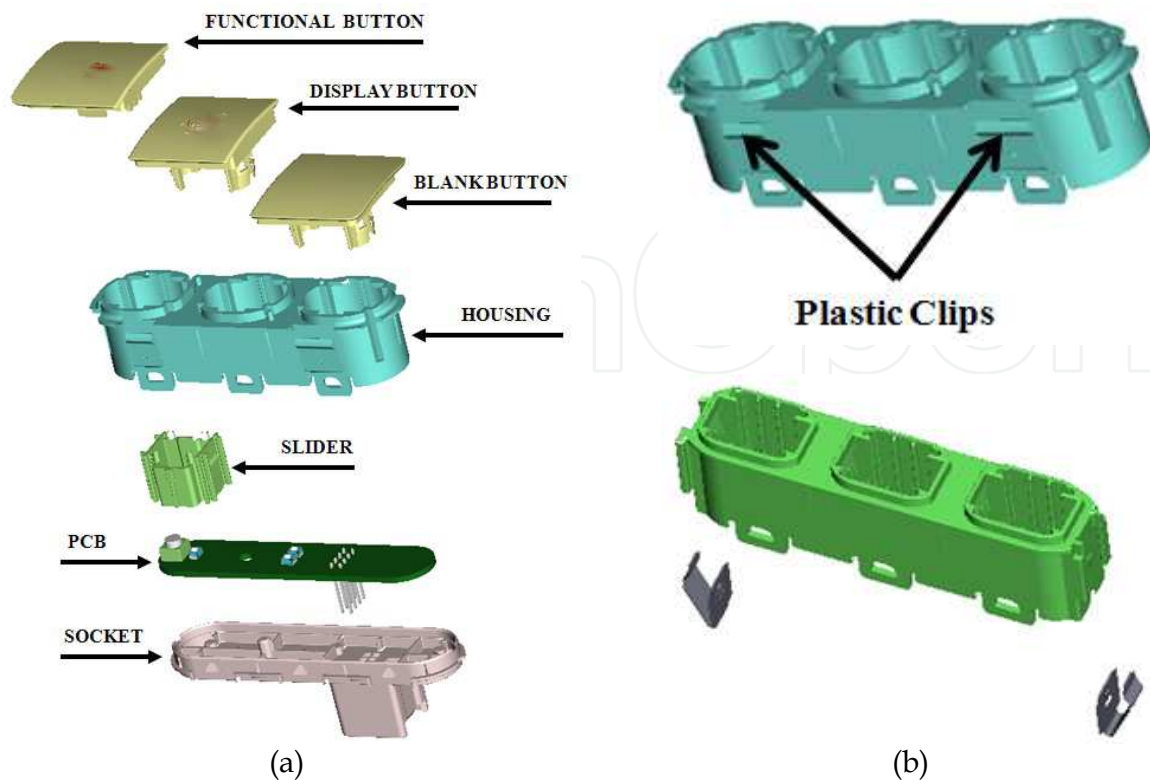

Fig. 3. (a) A variant of old three gang switch, (b) clipping mechanisms (top – old three gang; bottom – new three gang)

4.2 Analysis of the current manufacturing processes

The layouts of the existing production lines are illustrated in Figure 4, with the old three gang switches and some of the single gang switches manufactured in Cell 1, and the new three gang switches and the rest of the single gang switches manufactured in Cell 2. Due to limitations in the end of line testing steps, only one model of switch can be assembled on each cell at any one time, and substantial set-up times are associated with the change over between batches of different models of switch.

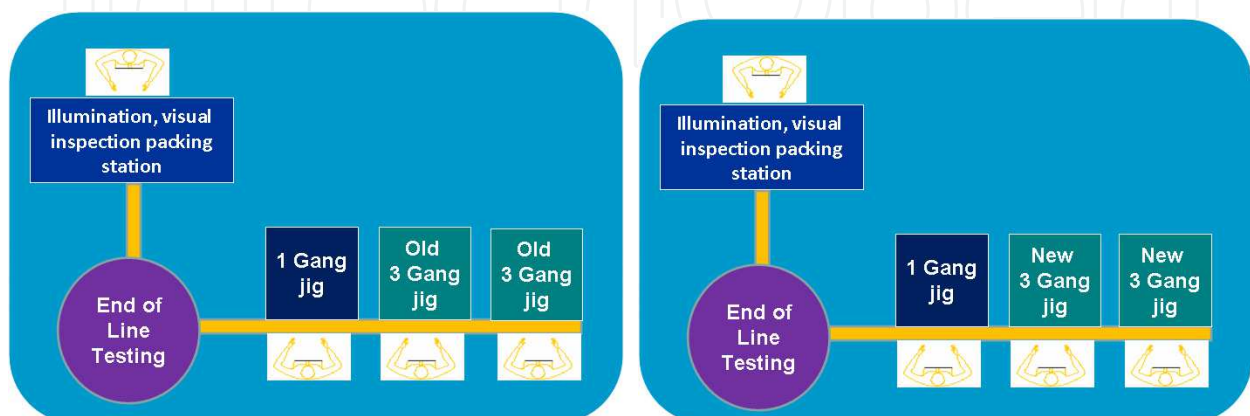

Fig. 4. (a) Layout of Cell 1, (b) layout of Cell 2

The labour intensive nature of the assembly process for the single gang switches is illustrated in Figure 5 and Figure 6. The operator reaches for one socket from the silo, and one PCB from the tray and places the socket over the PCB in cavity (1). If a chrome ring or light shield is required for the switch being assembled, the operator reaches for the chrome

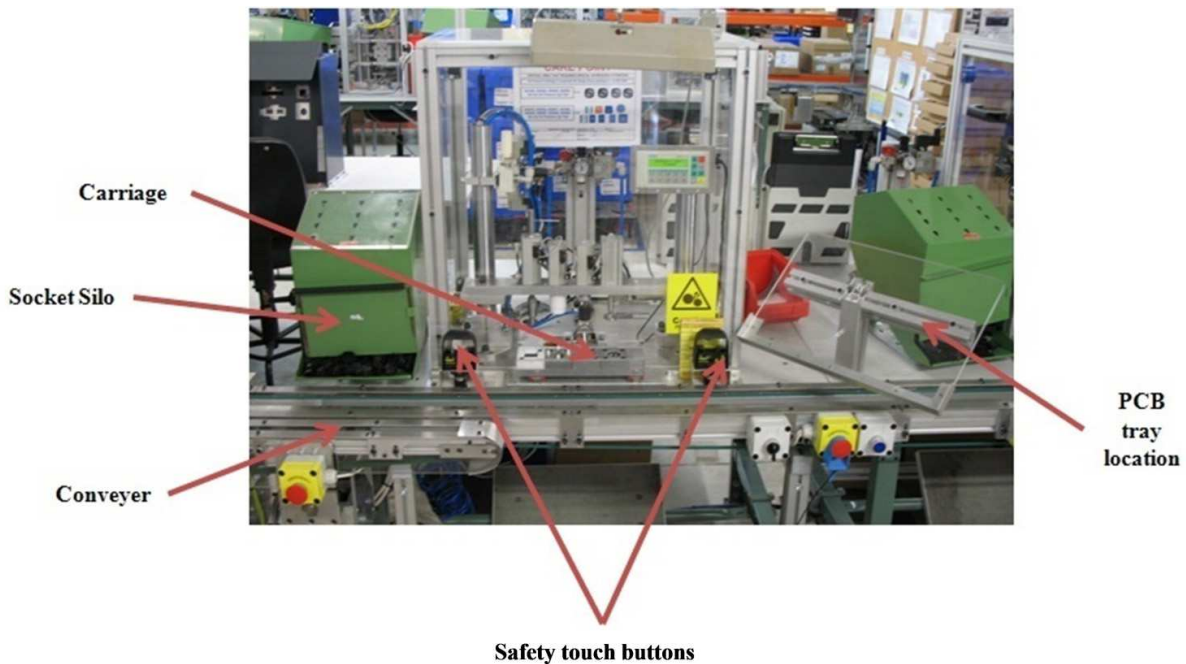

Fig. 5. Assembly jig for single gang switches

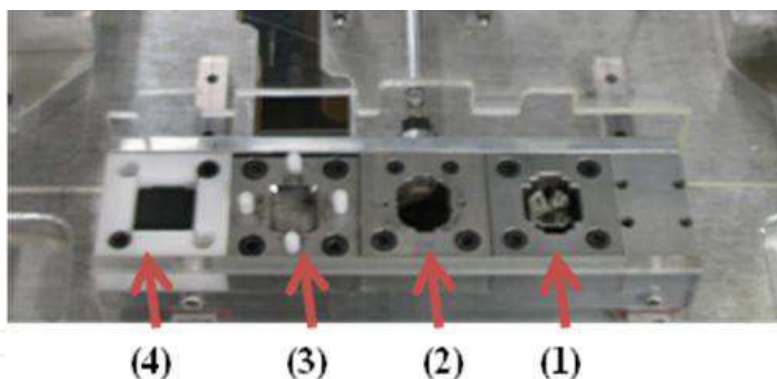

Fig. 6. The four cavities on the single gang switch assembly carriage

ring or light shield and for the button and performs manual alignment. A chrome ring and button sub-assembly is placed in cavity (3), while a light shield and button sub-assembly is placed in cavity (4). The operator then presses the two safety touch buttons placed on the sides of the assembly jig simultaneously. The carriage moves inside the jig and two pneumatic cylinders clip the socket and button sub-assemblies. Subsequently, the carriage moves outside the jig and the operator picks up the socket sub-assembly from cavity (1), rotates it and places it inside cavity (2), whilst placing the button sub-assemblies on top of it. The operator also loads the parts for another socket and button sub-assemblies so that during the jig operation, three clipping processes are performed simultaneously. The operator then presses the two safety buttons simultaneously and the carriage moves inside

the jig and a pneumatic cylinder clips the two sub-assemblies together. When the carriage moves outside the jig, the operator removes the switch and places it on the conveyor. For all the switches that require no chrome ring or light shield, the operator reaches for the button only when the socket sub-assembly has been placed in cavity (2).

Assembly of the three gang switches is somewhat more complex due to the greater number of parts, however the nature of the operations is similar.

The end of line testing is performed via a fully-automated four-station indexing table. The four stations are (i) a loading station which loads the assembled switch from the conveyor on to the station using a pneumatic pick and place device; (ii) a testing station where the switch is subjected to electrical and force testing, and (for the three gang switches) a barcode label is read; (iii) a camera and laser station where LED illumination intensity and graphic orientation is inspected, and where the customer part number and date code are engraved by laser; and (iv) an unloading station that transfers the switch, using a pick and place device, to a separate conveyor for final inspection, or onto a reject bin.

The final inspection and packaging workstation is fully manual. Here the operator ensures that no scratches, dents or other defects are present on the button's surfaces; checks the integrity of the clipping features; verifies that the terminals are not bent; and ensures that the correct laser marking and date code have been used. Conforming switches are subsequently packed in the respective packaging, whilst non-conforming switches are disposed of in the reject bin.

4.3 Capacity analysis for the current set-up

A capacity analysis was performed in order to quantify the number of switches that can be assembled and tested using the existing production lines. This was done by measuring the time required for every assembly process step of each switch variant, and by analyzing the cycle times and projected production volumes for each individual variant for the four years under consideration. In this respect, the *cycle time* is defined as the time interval for the completion of one complete production unit. In the case study considered, the cycle time was taken to be the longest time from among the three operations performed, i.e. *assembly cycle time* (the time taken to assemble one full switch), *testing cycle time* (the time taken to complete the longest testing step adding the indexing time of the table), and *finishing cycle time* (the time taken to inspect and pack). Equipment availability was assumed to run at 85%, which is due to (i) one product changeover of 15 minutes per shift, resulting in a 3.33% loss; (ii) an allowance of 30 minutes per shift for maintenance activities, including 15 minutes for breakdowns and 15 minutes for planned preventive maintenance, resulting in a 6.67% loss; (iii) personnel related stoppages of 10 minutes per shift resulting in a 2.22% loss; and (iv) process yield running at 97.5%. The number of shifts required to cater for these volumes could thus be calculated using an 85% equipment availability, with 7.5 operating hours per shift, for five days a week and 48 weeks per year.

The results of the capacity analysis are summarized in Table 3. Due to current layout constraints only two product families can be tested in parallel, and this means that the permissible total number of daily shifts is six. As can be seen in the table, during fiscal years 3 and 4, the total output cannot be reached because the number of daily shifts required is not achievable. In addition to this, during fiscal year 4 the number of daily shifts required to

achieve the required new three gang switch volumes is 3.11 which is not achievable, since new three gang switches can only be assembled and tested on cell 2. These results pointed out the need of improving the current layouts so as to cater for the required volumes.

| Fiscal Year | Number of Daily Shifts Required | | | Total Number of Daily Shifts Required |
|-------------|---------------------------------|----------------|----------------|---------------------------------------|
| | Single Gang | Old Three Gang | New Three Gang | |
| Year 1 | 0.30 | 2.55 | 0.00 | 2.85 |
| Year 2 | 2.28 | 1.97 | 0.32 | 4.57 |
| Year 3 | 3.38 | 1.97 | 1.81 | 7.16 |
| Year 4 | 3.75 | 1.97 | 3.11 | 8.83 |

Table 3. Number of shifts required to cater for the projected volumes using the existing production lines

4.4 Product design specification chart

A PDS chart contains a detailed list of *requirements* that the final product must fulfil, and is drawn up prior to starting the actual design. The aim of the PDS is to encompass all of the required information for a successful solution design and to ensure that the needs of the user are achieved. The PDS also lists a number of *wishes*, which are specifications that are not essential for the success of the project. These wishes however give the project a competitive edge and increase the potential benefits gained through its implementation.

A PDS chart was created for this project, listing all of the specifications that should be taken into account, when designing the required improvements on the switch manufacturing cells. The section of the chart dealing with the *performance* criterion of the production equipment is shown in Table 4. The other criteria that were considered were *target product cost, required service life, serviceability, safety, environment, size, ergonomics, materials, transportation, manufacturing facilities, appearance, quality and reliability, personnel requirements, product lifespan, documentation, and commissioning*.

Examples of design wishes (not shown in Table 4) include the minimization of shop floor space occupied by the equipment, the use of inexpensive (but reliable) materials, and the ability to manufacture the equipment in house.

| Specification | Requirement | Need |
|---|-------------|------|
| <i>Performance criterion</i> | | |
| Ability to assemble, test and finish the three switch families. | ✓ | |
| Ability to cater for the projected volumes, with an excess capacity of 15%. | ✓ | |
| An assembly cycle time for the new three gang switches of less than 10 seconds. | ✓ | |
| An assembly cycle time for the single gang switches of less than 8 seconds. | ✓ | |
| Ability to test single gang and three gang switches simultaneously. | ✓ | |

Table 4. A section of the PDS chart

4.5 Group technology analysis

In this case study, the preferred criterion for parts classification was found to be that based on product characteristics, since the parts fell into three natural groupings as discussed in section 4.1. The characteristics and variations of each of the three part families were analyzed in detail, with a view to confirming this classification and to prepare for the detailed technical design phase of the project.

An analysis of the constituent parts of the single gang switches produced the following results:

Button – there are different types of button, due to different customer requirements, mainly in terms of graphic design, shape and the type of surface. However all the buttons in the switch family have common guiding and clipping features.

Socket – two types of sockets exist with the main geometric difference being the position of the foolproof feature as shown in Figure 7. A second difference is in the socket colour, where type A is black and type B is grey.

PCB – there are different types of PCB having different profiles and different location of the electrical components.

Chrome Ring – there is only one type of chrome ring.

Jewel – the jewel needs to be aligned with the surface so it must have the same shape as the surface of the button. Two types of jewel exist that correspond to two types of surface.

Light Shield – there is only one type of light shield.

Similar analyses were carried out for the old three gang and new three gang switches. The part variations associated with all three product families are summarized in Table 5.

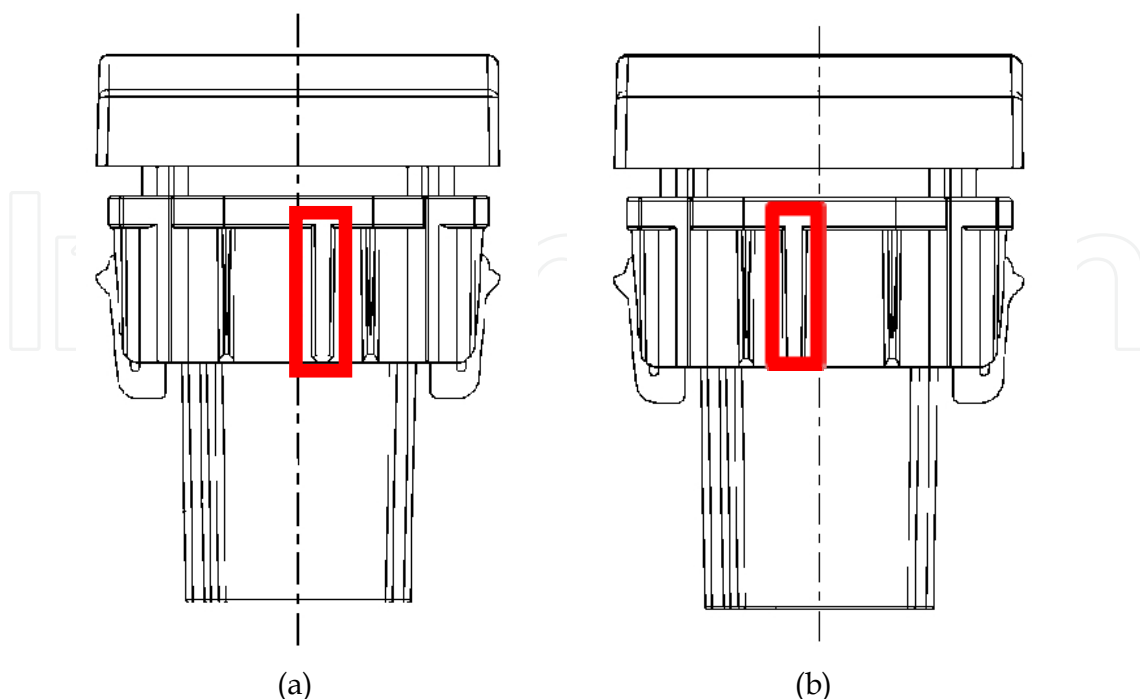

Fig. 7. The two types of socket for the single gang switch. (a) Type A, (b) Type B

| Single gang switches | | Old three gang switches | | New three gang switches | |
|----------------------|-----------------|-------------------------|-----------------|-------------------------|-----------------|
| Constituent part | No. of Variants | Constituent part | No. of Variants | Constituent part | No. of Variants |
| Button | 15 | Button set | 10 | Button set | 8 |
| Socket | 2 | Socket | 5 | Socket | 2 |
| PCB | 12 | PCB | 9 | PCB | 5 |
| Chrome ring | 1 | Housing | 1 | Housing | 1 |
| Jewel | 2 | Slider | 1 | Metal clip set | 1 |
| Light shield | 1 | | | | |

Table 5. Part variations for the three product families

From the results, it can be seen that there are substantial differences between the three sets of products, in terms of the gross geometries and of the constituent parts. In particular, it is noted that a different cavity is required for each of the three families (the geometric differences between the different types of socket within each switch family are minor, and in each case can be catered for by the same cavity). At the same time, the components that constitute each product family allow for ease of automation, since there are only a small number of variations for the parts. The analysis therefore confirmed the classification of the switches into three distinct product families as indicated in Table 5.

4.6 Precedence diagrams

The generalized manufacturing process flow chart for each switch, as extracted from the description given in section 4.2, is illustrated in Figure 8(a), and consists of three major steps. Step 1 involves the assembly of the switch. Step 2 involves the testing of the switch (force, electrical, and illumination testing) and laser marking. Step 3 involves a visual inspection of the switch and final packaging.

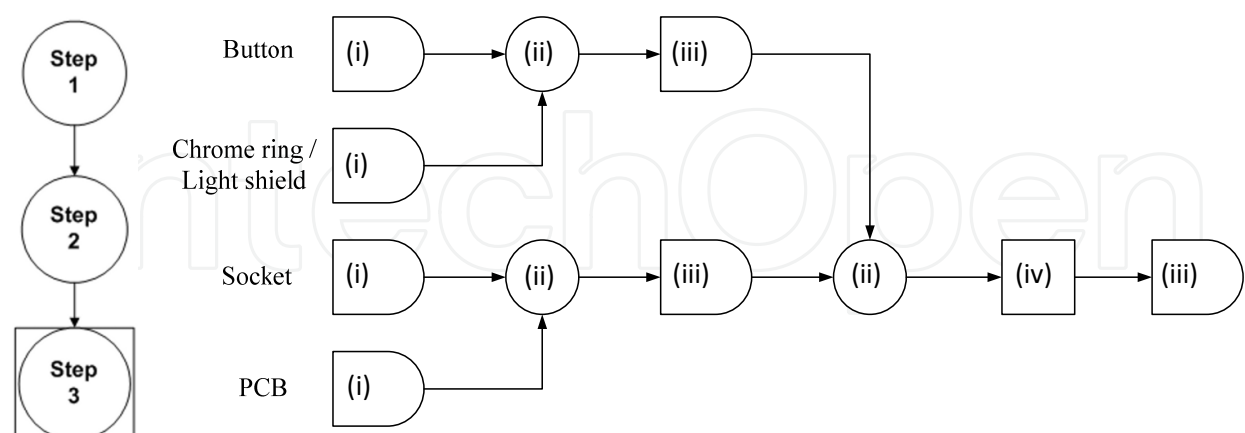

Fig. 8. (a) General process flow chart for each switch, (b) Precedence diagram for the assembly of a single gang switch

The precedence diagram for the assembly process (i.e. for Step 1) for the single gang switch is shown in Figure 8(b). In the figure, the shapes labelled (i) represent temporary storage, the circles labelled (ii) represent the complex operation “bring sub-components together, align,

and clip”, the shapes labelled (iii) represent delays, and the square labelled (iv) represents a brief visual verification that the clipping has been carried out correctly. For this particular case study it was not possible to simplify these steps any further.

The precedence diagrams for the old three gang and the new three gang switches were extracted in a similar manner. The three diagrams served to guide the development of the morphological chart, and the generation of alternative conceptual solutions, described in the next two sections.

4.7 Morphological chart

A morphological chart is an analytical tool which aims at finding all theoretically conceivable solutions to a problem (Roozenburg & Eekels, 1995). It provides a visual way of capturing the required product functions and of exploring possible different solutions that may exist for each product function. The chart facilitates the presentation of these solutions and provides a framework for considering alternative combinations of the individual function solutions.

The main functions associated with the problem at hand were identified to be the (i) transfer system between stations, (ii) part orienting mechanism, (iii) part feeding mechanism, (iv) handling mechanism, (v) gripping mechanism, (vi) part inspection system, and (vii) part packaging. The morphological chart is shown in Table 6.

| Function | Option 1 | Option 2 | Option 3 | Option 4 |
|--------------------------------|--------------------------|--|--|---------------|
| Transfer System | In-line indexing system | In-Line indexing system with return carriers in the vertical plane | Rotary indexing system | Pallet system |
| Part Orienting | Vibratory bowl feeder | Magnetic rotary feeder | Machine vision system coupled with a robotic arm | Manual |
| Part Feeding | Vibrating conveyor | Linear feeder | Horizontal belt conveyor with passive guides | Manual |
| Handling System | Pneumatic pick and place | Electric pick and place | Robotic arm | Manual |
| Part Gripping | Vacuum suction | Magnetic gripping | Pneumatic grippers: radial, 3-point and angular | Manual |
| Part Inspection Systems | Machine vision system | Colour sensor | Human visual inspection | |
| Packaging System | Robot based system | Customized automation | Manual | |

Table 6. Morphological chart for the new manufacturing system. The selected solutions are highlighted.

Solution selection was made on the following bases:

Transfer system – The projected high production volumes necessitate a low indexing time, and if a pallet system is used this would only be achievable by using a very large number of pallets. Thus the manufacturing cost of the system would increase due to the large number of cavities required. A rotary indexing table reduces maintenance interventions, since maintenance requirements are less compared to that of an in-line indexing system.

Part orienting – A vibratory bowl feeder can provide the required output, and is the cheapest and most reliable solution among the four options considered.

Part feeding – High part feeding accuracy is required in order to ensure correct operation of the system and this accuracy can be achieved through the use of linear feeders coupled with vibratory bowl feeders. The use of vibration conveyors or of passive guides cannot achieve the required accuracy. The manual option is expensive.

Handling system – The transportation of the part between two fixed positions can easily be achieved by a pneumatic handling system, which is the cheapest alternative among the four considered.

Part gripping – A system based on vacuum suction could be used, however for its full implementation a number of intricate vacuum heads would need to be designed, thus substantially increasing the cost of the system. A magnetic system cannot be used for all components, since most of the components are made of plastic. A manual system is an expensive option and therefore pneumatic grippers with specifically designed jaws were selected.

Part inspection system – Visual inspection is required at the end of line testing stage (which is already automated, and uses a machine vision system) and at the final inspection station. Due to the complex nature of the final inspection it was determined that this could only be carried out reliably by human operators.

Packaging system – Since the final inspection is manual, the preferred option would be to have the human operator package the completed switch after inspection.

4.8 Concept generation

4.8.1 Overview of proposed concepts

Four different concept layouts were generated to address the problem. The first concept involves automation of the single gang switch assembly, and relocation of all assembly of this switch to Cell 1. Assembly of the new three gang switch would also be automated, and Cell 2 would be dedicated to this process. The second concept involves the retention of the present, labour intensive, assembly processes, but with the incorporation of an additional station to Cell 2 for the assembly of new three gang switches, to meet the projected production volumes. The third concept is a compromise between the approaches of the first and second concepts, and involves the retention of the present, labour intensive, assembly processes for the single gang switch and for the old three gang switch, and the transfer of the single gang switch assembly station from Cell 2 to Cell 1. Cell 2 would be dedicated to the automated production of the new three gang switches as in Concept 1. The fourth concept involves the combination of all production processes into a single cell, and

automating the assembly of the single gang and of the new three gang switches. It is noted that due to the fact that the production volume of the old three gang switches is expected to decrease, automation of the assembly process for these switches is not recommended under any of the proposed concepts. The four concepts are presented in greater detail in the following sections.

4.8.2 Concept 1

The proposed layout for Cell 1 under this approach is shown in Figure 9. The cell consists of an indexing table used for the assembly of the single gang switches, two manual jigs used for the assembly of the old three gang switches and a testing indexing table which can test the two different switches simultaneously. Linear conveyors transfer the switches from the assembly stations to the testing station. An operator loads the PCB and button on Station 1 of the loading indexing table. The work carrier of this indexing table will be sub-divided into two sections, one holding the PCB and one the button. These two parts are bought-in parts presented to assembly in painting jigs or trays and therefore automation of the loading function would require a tray changing mechanism and an x-y-z pick and place device. The

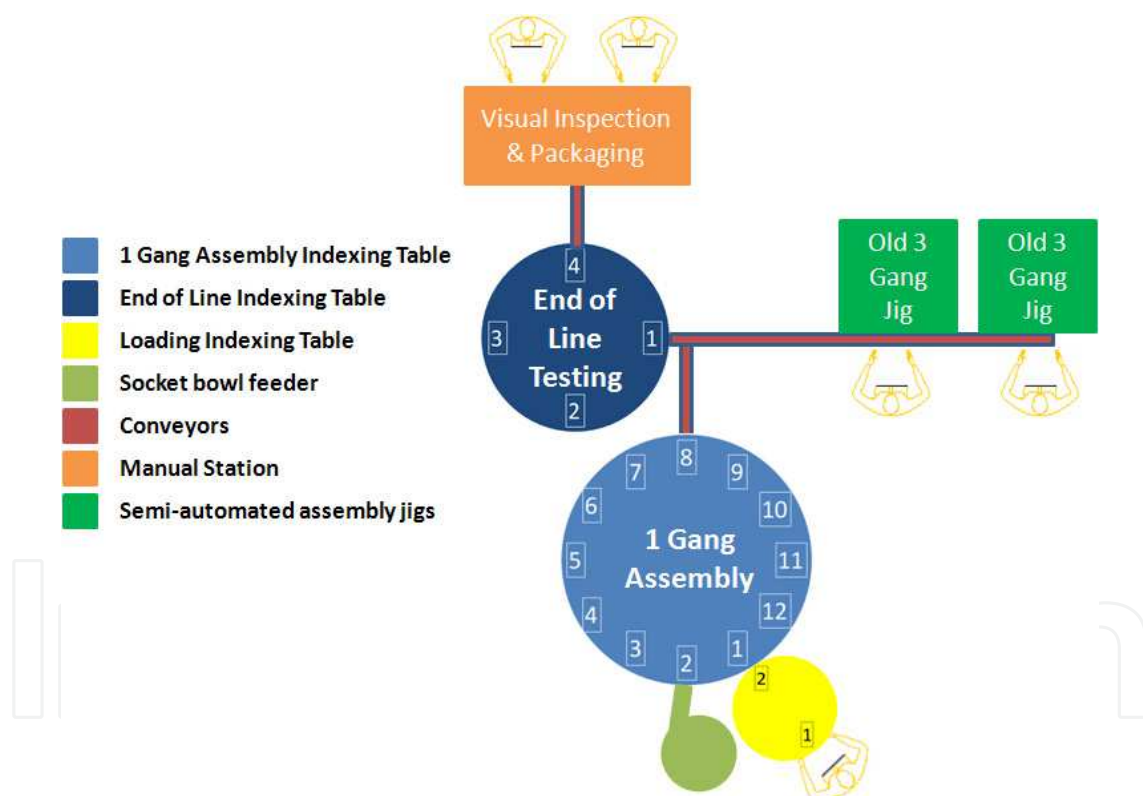

Fig. 9. Proposed Layout for Cell 1 (Concept 1)

initial cost required to create these subsystems would be much higher than the operational cost of one operator who would still be required to attend the machine, and their implementation is therefore not recommended. The parts are then automatically transferred onto a twelve station indexing table. The work carrier on this indexing table will be sub-divided into three sections, namely cavities 1, 2 and 3. The proposed stations for the indexing table are listed in Table 7. The twelve station indexing table was chosen because

one is already available at the company, thus reducing the initial cost required. This results in five free stations which can be utilized for future improvements of the layout. The fully assembled single gang and old three gang switches are unloaded onto conveyors which transfer them to the end of line indexing table, based on the current automated system. Table 8 lists the four stations of the fully automated indexing table. The loading station will either pick up one switch type or both switch types, depending upon the switch being available at the conveyor, since old three gang and single gang assemblies would not be synchronized. A new anti-mixing part inspection system, based on machine vision, would need to be incorporated into the end of line testing station, to distinguish between the two switch families.

| Station | Description |
|---------|---|
| 1 | Loading of button onto cavity 3 and PCB onto cavity 1 |
| 2 | Loading of socket onto PCB |
| 3 | Clipping of socket to PCB (sub-assembly 1) |
| 4 | Turning of socket and placing onto cavity 2 |
| 5 | Free station |
| 6 | Loading of button onto sub-assembly 1 |
| 7 | Clipping of button with sub-assembly 1 |
| 8 | Unloading |
| 9 | Free station |
| 10 | Free station |
| 11 | Free station |
| 12 | Free station |

Table 7. Single gang switch assembly stations (Concept 1, Cell 1)

| Station | Description |
|---------|------------------------------|
| 1 | Loading |
| 2 | Force and electrical testing |
| 3 | Camera test and laser mark |
| 4 | Unloading |

Table 8. End of line testing stations (all concepts, all cells)

The proposed layout for Cell 2 consists of a semi-automated twelve station indexing table, used for the assembly of new three gang switches, as shown in Figure 10. The work carrier on this indexing table will be sub-divided into three sections, namely cavities 1, 2 and 3. The socket, clips and housing are oriented via vibratory bowl feeders and automatically loaded on the respective stations. The PCB is manually loaded on a conveyor which is then automatically transferred onto the socket in station 2. Table 9 lists the proposed operations to be performed by each station. The PCB and buttons are manually loaded as in Cell 1. In station 3, the sub-assembled components are unloaded onto a conveyor and the same operator loading the PCB, adds a label to the sub-assembly. Subsequently a second operator adds the three buttons in their corresponding position and places the switch onto a third conveyor. The clipping of the buttons is performed via an automatic clipping and pre-actuation station and finally the switch is loaded onto the testing indexing table. The end of line indexing table is similar to the one on Cell 1.

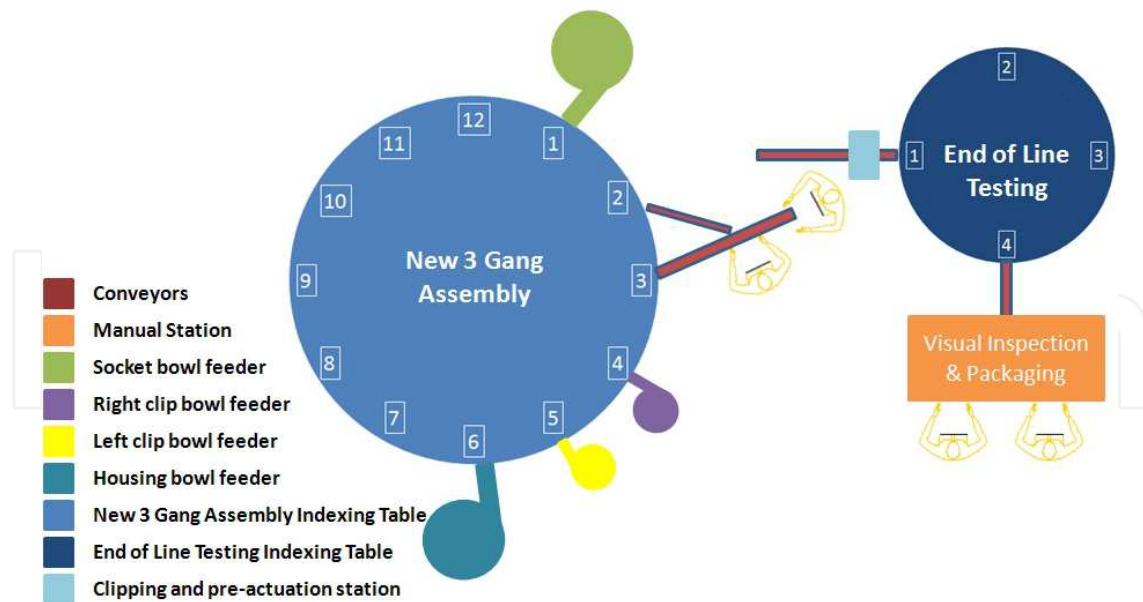

Fig. 10. Proposed layout for Cell 2 (Concept 1)

| Station | Description |
|---------|---|
| 1 | Loading of Socket in cavity 1 |
| 2 | Loading of PCB onto socket in cavity 1 - (sub-assembly 1) |
| 3 | Unloading of sub-assembly 3 onto conveyor from cavity 2 |
| 4 | Loading of right clip in cavity 3 |
| 5 | Loading of left clip in cavity 3 |
| 6 | Loading of housing onto clips in cavity 3 |
| 7 | Clipping of housing with clips - (sub-assembly 2) |
| 8 | Loading of sub-assembly 2 onto sub-assembly 1 in cavity 1 |
| 9 | Clipping of sub-assembly 2 onto sub-assembly 1 - (sub-assembly 3) |
| 10 | Transfer of sub-assembly 3 onto cavity 2 |
| 11 | Free Station |
| 12 | Free Station |

Table 9. New three gang switch assembly stations (Concept 1, Cell 2)

4.8.3 Concept 2

The proposed layouts under this approach are shown in Figure 11. This concept entails the incorporation of an additional manual assembly jig to Cell 2 that would be used for the assembly of new three gang switches. This is achieved by modifying the conveyor currently used to transfer the assembled parts from the jigs to the testing indexing table, so as to cater for the additional jig. Changes are also proposed to the testing program of both end of line testers, so as to reduce the testing time required. A new operator is required for the visual inspection and packaging station of Cell 2, so as to cater for all the switches being assembled. Two operators would thus be dedicated to new three gang switches, and one to single gang switches. This concept is a labour intensive concept which however requires less initial investment due to the fact that only minor modifications are required to the existing structure. The projected production volumes can however still be met through this layout.

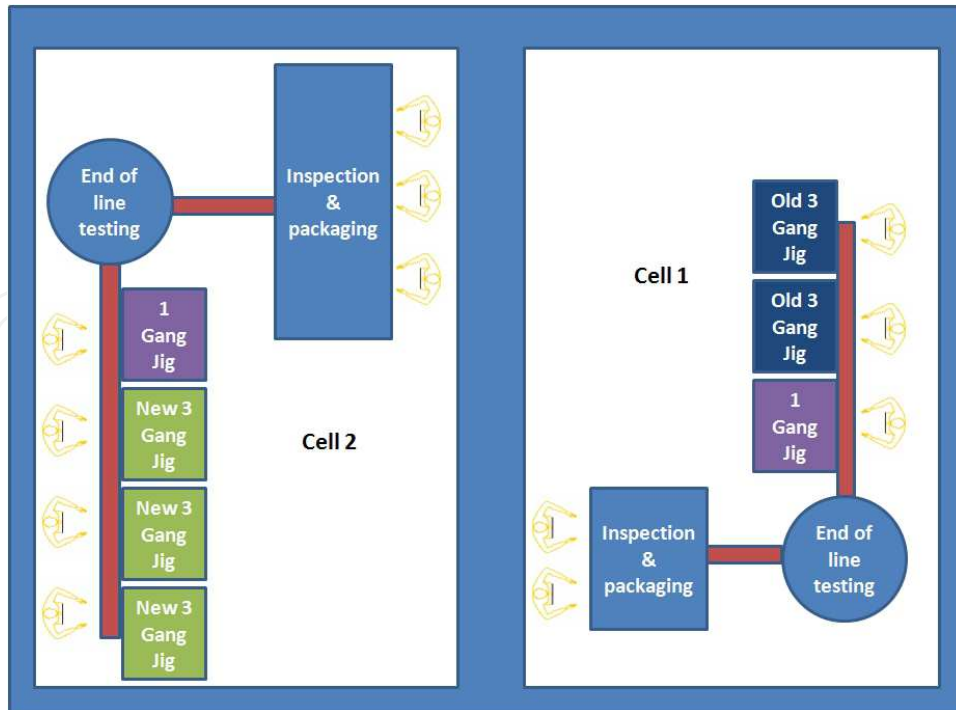

Fig. 11. Proposed layouts for Cell 1 and Cell 2 (Concept 2)

4.8.4 Concept 3

The layouts of the cells under this approach, as described in section 4.8.1, are shown in Figure 12. Modifications are required to the testing program of both cells so as to reduce the testing cycle time.

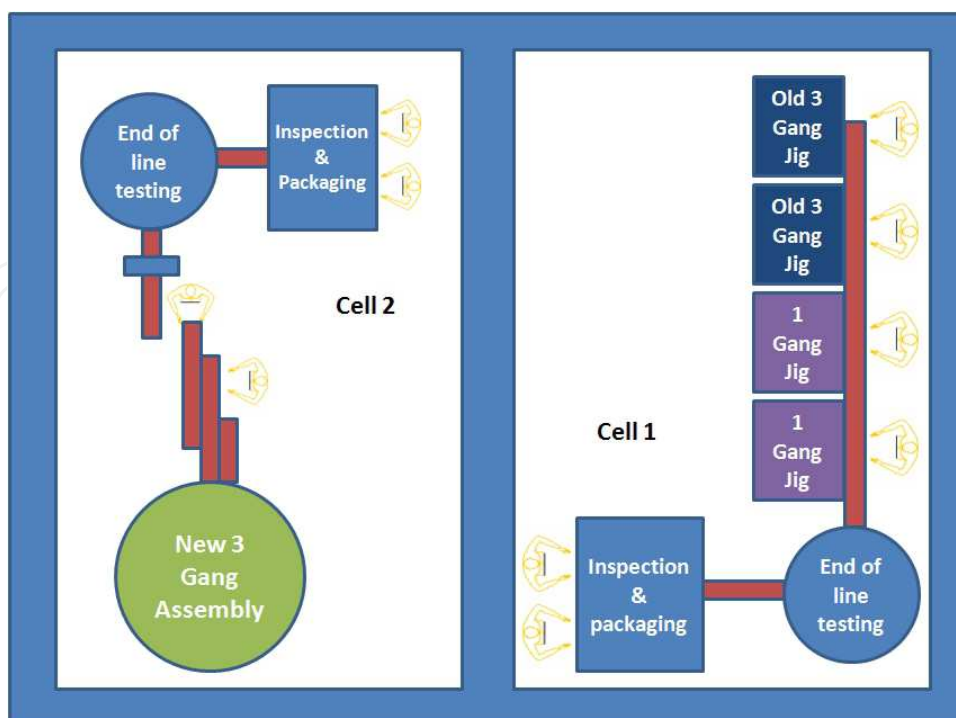

Fig. 12. Proposed layouts for Cell 1 and Cell 2 (Concept 3)

4.8.5 Concept 4

The fourth concept consists of one indexing table that is used for the assembly of both the single gang and the new three gang switches, as shown in Figure 13. A 20-station indexing table is used having work carriers divided into six sections, where three sections (cavities 1, 2 and 3) are used for new three gang switches and the other three (cavities 4, 5 and 6) are used for single gang switches. The main difference between this layout and the one proposed in Concept 1 involves the combination of the two assembly lines. The orienting, feeding, loading and clipping mechanisms are the same as those proposed in Concept 1. The proposed stations are listed in Table 10, where it can be seen that the first twelve stations are dedicated to the new three gang switches and the remaining eight stations to the single gang switches. There would be a total of three free stations. The end of line testing systems are the same as those proposed in Concept 1.

| Switch | Station | Description |
|---------------------------------------|---------|---|
| New Three Gang Switch Assembly | 1 | Loading of socket in cavity 1 |
| | 2 | Loading of PCB onto socket in cavity 1 - (sub-assembly 1) |
| | 3 | Unloading of sub-assembly 1 onto conveyor |
| | 4 | Loading of right clip in cavity 3 |
| | 5 | Loading of left clip in cavity 3 |
| | 6 | Loading of housing onto clips in cavity 3 |
| | 7 | Clipping of housing with clips - (sub-assembly 2) |
| | 8 | Loading of sub-assembly 2 onto sub-assembly 1 in cavity 1 |
| | 9 | Clipping of sub-assembly 2 onto sub-assembly 1 - (sub-assembly 3) |
| | 10 | Transfer of sub-assembly 3 onto cavity 2 |
| | 11 | Free station |
| | 12 | Free station |
| Single Gang Switch Assembly | 13 | Loading of button onto cavity 6 and PCB onto cavity 4 |
| | 14 | Loading of socket onto PCB in cavity 4 |
| | 15 | Clipping of socket to PCB (sub-assembly 4) |
| | 16 | Turning of sub-assembly 4 and placing onto cavity 5 |
| | 17 | Free station |
| | 18 | Loading of button onto sub-assembly 4 |
| | 19 | Clipping of button with sub-assembly 4 |
| | 20 | Unloading |

Table 10. Assembly stations for the single gang and new three gang switches (Concept 4)

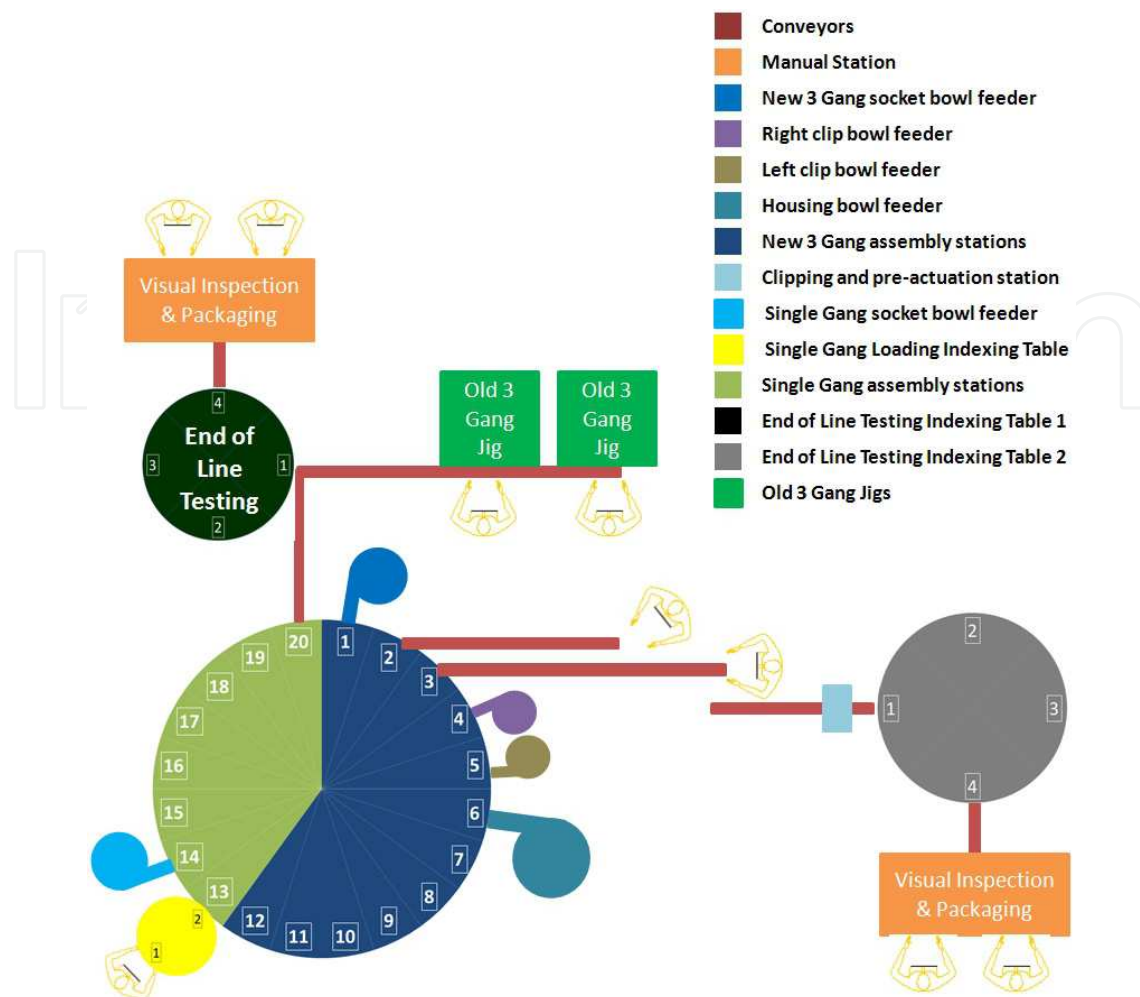

Fig. 13. Proposed layout for combined assembly in a single cell (Concept 4)

4.9 Provisional analytical studies

4.9.1 Overview of analysis

The proposed concepts were analyzed with respect to a number of parameters, namely *cycle time*, *initial investment cost*, *labour requirements*, *line balancing*, *final product quality*, *shop floor area consumed*, *lead time to manufacturing the equipment*, *maintenance requirements*, *knowledge transfer availability*, and *flexibility*.

4.9.2 Cycle time

The production of a switch consists of three main operations, namely assembly, testing and finishing. The production cycle time corresponds to the longest cycle time from among these three operations. In order to derive the individual cycle time of each operation, the expected duration of every manufacturing step for each of the proposed concepts was estimated, and the operation cycle time is then given by the longest duration from among its individual stations, taking into account also the indexing time where applicable. It was found that the bottleneck of the production line for all four concepts is the assembly operation. The results of the analysis are summarized in Table 11.

| | Single gang | Old three gang | New three gang |
|-----------|-------------|----------------|----------------|
| Concept 1 | 6.0s | 15.0s | 6.0s |
| Concept 2 | 8.5s | 15.0s | 10.8s |
| Concept 3 | 8.5s | 15.0s | 6.0s |
| Concept 4 | 6.0s | 15.0s | 6.0s |

Table 11. Production cycle times for each switch family under each concept

4.9.3 Initial investment costs

The initial costs associated with each concept were estimated. It was found that Concept 4 would be the most expensive to implement, followed by Concept 1, Concept 3, and Concept 2 respectively.

4.9.4 Labour requirements

The total number of human operators required for each conceptual approach was determined. Based on the descriptions given in section 4.8, Concept 1 would require nine operators, Concept 2 would require twelve operators, Concept 3 would require ten operators, and Concept 4 would require nine operators.

4.9.5 Line balancing

The *balance efficiency* of a production line is a measure of the time used for productive work at each station as compared to the total available time (e.g. Groover, 2001). In a perfectly balanced line (i.e. 100% balance efficiency) the durations of the jobs carried out at each individual station (be they manual or automated) would be exactly equal to each other (and equal to the cycle time), and there would be no idle time at any station. In practice this ideal situation is very difficult to obtain since it is unlikely that the total work required can be broken down into discrete steps of exactly the same duration, however it remains important to strive for as high an efficiency as possible. The achievable line balance efficiencies for the four concepts described in section 4.8 are given in Table 12.

| | Single gang | New three gang |
|-----------|-------------|----------------|
| Concept 1 | 63% | 68% |
| Concept 2 | 60% | 59% |
| Concept 3 | 60% | 68% |
| Concept 4 | 68% | |

Table 12. Balance efficiencies for the single gang and new three gang switch families under each concept

4.9.6 Final product quality

The increase in production rate should not be achieved at the expense of reduced product quality and therefore all concepts considered were developed with great concern towards maintaining high quality standards. Thus for example, the proposed automatic handling of buttons would be performed without any part coming into contact with the surface of the button. Given that a well designed automation system is often capable of greater consistency

than a system based on human operators, it would be expected that product quality would increase through greater use of automation.

4.9.7 Shop floor area consumed

Due to limitations in the shop floor area, the space consumed by the manufacturing lines would need to be minimized. It was estimated that approximately 55 m² of floor area would be consumed by the cells under Concept 1, 50 m² under Concept 2, 50 m² under Concept 3, and 90 m² under Concept 4.

4.9.8 Lead time to manufacturing the equipment

The development of a new production line involves the mechanical and electrical systems design, manufacture of the required components, wiring and programming of the system, and assembly, tuning, and testing of the system. It was estimated that for Concept 1 the total lead time would be approximately 28 weeks, for Concept 2 it would be 2.5 weeks, for Concept 3 it would be 23 weeks, and for Concept 4 it would be 29 weeks.

4.9.9 Maintenance requirements

The selected system would require both preventive and corrective maintenance tasks in order to function correctly over a period of time. The time required to perform such maintenance translates into lost production time and therefore the maintenance requirements of the developed concept need to be minimized so as to maximise productivity and efficiency. The maintenance requirements increase with the number of mechanical, pneumatic and electrical components in the system. Thus Concept 1 and Concept 4, which contain indexing tables, automated stations and vibratory bowl feeders would have higher maintenance requirements than would Concept 2 which contains only mechanized jigs.

4.9.10 Knowledge transfer availability

In today's competitive market, cost reduction and shorter lead time to market are very important. Knowledge transfer aims at achieving these goals, through sharing of the knowledge learnt from previous projects, especially in terms of technologies and procedures. The four conceptual solutions are based on layout styles that are already widely applied at the company and therefore personnel are already experienced with similar equipment. This results in a reduction of the lead time to implement the concept and an improvement in operation and troubleshooting efficiency.

4.9.11 Flexibility

The number of distinct members of the three switch families is expected to increase in the next few years. All four concepts that have been generated allow for these expected new variations, however future customer requirements are difficult to forecast with precision. The *automation* concepts that have been proposed are based on fixed automation systems and thus would not allow for major variations in switch design. An increased flexibility is however supplied by the *manual* assembly jigs since in the associated concepts, potential future changes to the switch design can be more easily catered for by the human operators.

4.10 The decision matrix

Concept selection was based on a decision matrix. The ten criteria discussed in section 4.9 were ranked in order of importance, in consultation with experienced company personnel, and were subsequently given a weighting ranging from 10 for the most important criterion, to 1 for the least important. Each concept was then assigned an individual score for each criterion, based on the analysis of section 4.9. The total score for each concept was then obtained from the weighted sum of the individual scores. The complete decision matrix is shown in Table 13. Based on this result, the selected solution was based on Concept 1.

| Selection criterion | Weighting | Concept 1 | Concept 2 | Concept 3 | Concept 4 |
|---------------------------------|-----------|-----------|-----------|-----------|-----------|
| Labour requirements | 10 | 7 | 1 | 3 | 7 |
| Cycle time | 9 | 7 | 1 | 3 | 7 |
| Final product quality | 8 | 7 | 1 | 3 | 7 |
| Initial investment cost | 7 | 3 | 7 | 5 | 1 |
| Line balancing | 6 | 5 | 1 | 3 | 7 |
| Knowledge transfer availability | 5 | 3 | 3 | 3 | 3 |
| Flexibility | 4 | 1 | 5 | 3 | 1 |
| Lead time to manufacture | 3 | 3 | 7 | 5 | 1 |
| Shop floor area consumed | 2 | 5 | 7 | 7 | 1 |
| Maintenance requirements | 1 | 3 | 7 | 5 | 3 |
| TOTAL | | 281 | 159 | 195 | 265 |

Table 13. The decision matrix

4.11 Process failure modes and effects analysis

A process failure modes and effects analysis (PFMEA) is a detailed analysis of the errors and malfunctions that can occur during an engineering process, including assessment of the severity, probability of occurrence, and effects of the potential malfunctions, with a view to improve the process design and reliability. An extensive PFMEA was carried out on the selected concept, searching for and assessing various potential failure modes at every station of both production cells. In addition to the various specific process design provisions that were made to address each failure mode that was identified and evaluated through the PFMEA, a number of general conclusions could be drawn from the qualitative and quantitative results of the exercise. Firstly, it was noted that various mistakes can be made by the human operators at the manual stations, and that these mistakes can be minimized by providing clear and concise working instructions to the operators. In this respect all necessary training must also be given. Secondly, it was noted that malfunction of the grippers and air supply, and errors in alignment and settings, can have significant but avoidable detrimental effects on the production process. During the PFMEA a high severity rating was assigned to all of the pick and place operations, to motivate special attention to all associated production line components during commissioning. These ratings would later need to be revised so as to reflect better the

final conditions of the line. Thirdly, due to the fact that numerous variants exist for the parts being assembled, the risk of product misidentification and mixing is high. Therefore inspection tests need to be performed in order to detect this failure mode, and this can be achieved through the addition of colour sensors on the linear feeder, a camera inspection on the end of line testing, and an automatic bar code scanner. Fourthly, it is noted that as a final measure, all potential failure modes can be detected by the end of line tests being performed, thus ensuring high reliability of the final product being delivered to the customer.

4.12 Safety analysis

In order to ensure that all safety considerations are integrated within the project as early as possible in the design process, a safety analysis was performed on the selected concept. The analysis followed the five step approach recommended by Bahr (1997) – Step 1: Define the system; Step 2: Identify the hazards; Step 3: Evaluate the hazards; Step 4: Resolve the hazards; and Step 5: Carry out follow-up activity. The system was defined (Step 1) to encompass the two production lines (Cell 1 and Cell 2). The results of Step 2 through Step 4 of the safety analysis are summarized in Table 14. Step 5 can be realized through continued regular checks to ensure: effectiveness of all safety modules; correct functionality of all emergency stop buttons; presence of all protective covers and that all covers are tightly fixed; no cutting edges have been created by wear and tear of the machine; presence of all required grounding systems; and effectiveness of the extraction system and regular filter replacement.

4.13 Ergonomic analysis

In order to improve worker interaction with the system being operated, ergonomic principles were applied to the system design, so as to accommodate human needs. This improves operator performance and well-being, resulting in an increase in overall system performance and efficiency. The analysis has been performed on the manual workstations to ensure that the most ergonomic design is chosen. The ergonomic design specifications are based on the recommendations in Kanawaty (1992) and Wojcikiewicz (2003).

The height of the seated workbench is to be set at approximately 0.72 m so as to ensure that the worker's arms are below the shoulders. The leg clearance should be approximately 0.4 m at knee level and 0.6 m for the feet, without any obstructions such as drawers, between the legs. Height adjustable chairs are to be utilised for the all manned workstations, so as to ensure that the back and neck are not inclined more than 30°. A foot rest should also be available for operators if required. All silos and trays containing assembly parts should be placed within the maximum reach area of the operator, whereas the cavity should be placed within the optimum reach area. Movement of the eyes should be minimized since it takes approximately three seconds for the eyes to rotate and re-focus. Therefore the buttons and the work-piece should be placed within the 15° view angle, on either side of the centreline, since this angle requires no eye movement to allow for the grabbing of the parts. Part silos and the label printer should be placed within the 35° view angle. Correct lighting should be available since this helps to reduce errors and thus improve productivity. The light intensity requirement for the operations to be

performed in this case study should be about 500 lux, where one lux is given by the illumination of a surface placed one meter away from a single candle. The light should be uniformly distributed so as to avoid pronounced shadows and excessive contrasts.

| Category | Hazard description | Potential causal factors | Sev. | Occ. | Hazard Resolution |
|-------------------------|---|---|------|------|---|
| Mechanical | Crushing of body part | Unexpected movement of pneumatic cylinders | II | A | Safety guards with interlocks |
| | | Unexpected movement of electric motors on testing station | II | A | |
| | Operator cuts a body part | Sharp Edges on equipment | III | B | Chamfers and edge deburring |
| | Operator catches a body part in a pinch point | Pulleys controlling conveyor movement | II | B | Protective covers for all pulleys |
| | Impact | Unexpected movement of pneumatic cylinders | II | B | Safety guards with interlocks |
| | | Unexpected movement of indexing table | II | B | |
| | Wrap Points | Entanglement of clothing and accessories with conveyor | III | C | Protective covers for all pulleys; emergency stops |
| Electrical / Electronic | Energized equipment resulting in electric shock | Improper electrical connections and wiring | I | C | Include fuses, circuit breakers, and electrical grounding; use electrical safety checklist with double-checking; enclose wiring in control box; emergency stop switches |
| | | Poor insulation | I | D | |
| | | Insufficient grounding | I | D | |
| | | Inadvertent activation | I | B | |

Severity key: I-Catastrophic; II-Critical; III-Marginal; IV-Negligible.

Occurrence key: A-Frequent; B-Probable; C-Occasional; D-Remote; E-Improbable

Table 14. (first part) Safety analysis: identification, evaluation, and resolution of hazard

| Category | Hazard description | Potential causal factors | Sev. | Occ. | Hazard Resolution |
|-------------------|------------------------------|---|------|------|--|
| Noise / Vibration | Permanent damage to hearing | Environmental sound level exceeds 80dBA | II | B | Pneumatic cylinders equipped with silencers. |
| | Personnel fatigue | Excessive vibrations to operator's workstation | III | A | No vibratory or linear feeders placed in proximity to operators' workstations. |
| Lasers | Eye exposure | Collimated beam direct from the laser head into the operator's eyes | II | C | Laser systems enclosed by safety guards with interlocks |
| | Burning of operator hands | Collimated beam direct from the laser head over the operator's hand | II | C | |
| | Operator inhales toxic fumes | Toxic fumes arising from burning of plastics by laser marking. | III | A | Fume extraction system |

Severity key: I-Catastrophic; II-Critical; III-Marginal; IV-Negligible.

Occurrence key: A-Frequent; B-Probable; C-Occasional; D-Remote; E-Improbable

Table 14. (continued) Safety analysis: identification, evaluation, and resolution of hazards

4.14 New capacity analysis

A detailed capacity analysis was carried out on the proposed production system, based on the assumptions made in section 4.3. The results of this analysis are summarized in Table 15. The total required output can be reached easily using the proposed system, and even in the most demanding year (Year 4) there is a substantial reserve capacity.

| Fiscal Year | Number of Daily Shifts Required | | | Total Number of Daily Shifts Required |
|-------------|---------------------------------|----------------|----------------|---------------------------------------|
| | Single Gang | Old Three Gang | New Three Gang | |
| Year 1 | 0.15 | 2.55 | 0.00 | 2.70 |
| Year 2 | 1.02 | 1.97 | 0.16 | 3.15 |
| Year 3 | 1.54 | 1.97 | 0.94 | 4.45 |
| Year 4 | 1.67 | 1.97 | 1.63 | 5.27 |

Table 15. Number of shifts required to cater for the projected volumes using the proposed production lines

4.15 Provisional return on investment analysis

In order to estimate the financial benefits that would be gained by the company upon the implementation of the proposed layouts, a provisional return on investment analysis was carried out. The operational cost savings were calculated by comparing labour costs under the present and the proposed layouts. The labour seconds required to manufacture each switch was calculated by multiplying the cycle time by the number of operators required to operate the cell. These calculations indicate substantial cost savings over the four year period, with return on the initial investment achieved in less than three years.

5. Conceptual drawings

While not included among the more critical procedural guidelines proposed in section 3 above, the generation of three-dimensional renditions of the conceptual design of a system helps the design team visualize the overall concept and may aid in the optimization of the spatial layout.

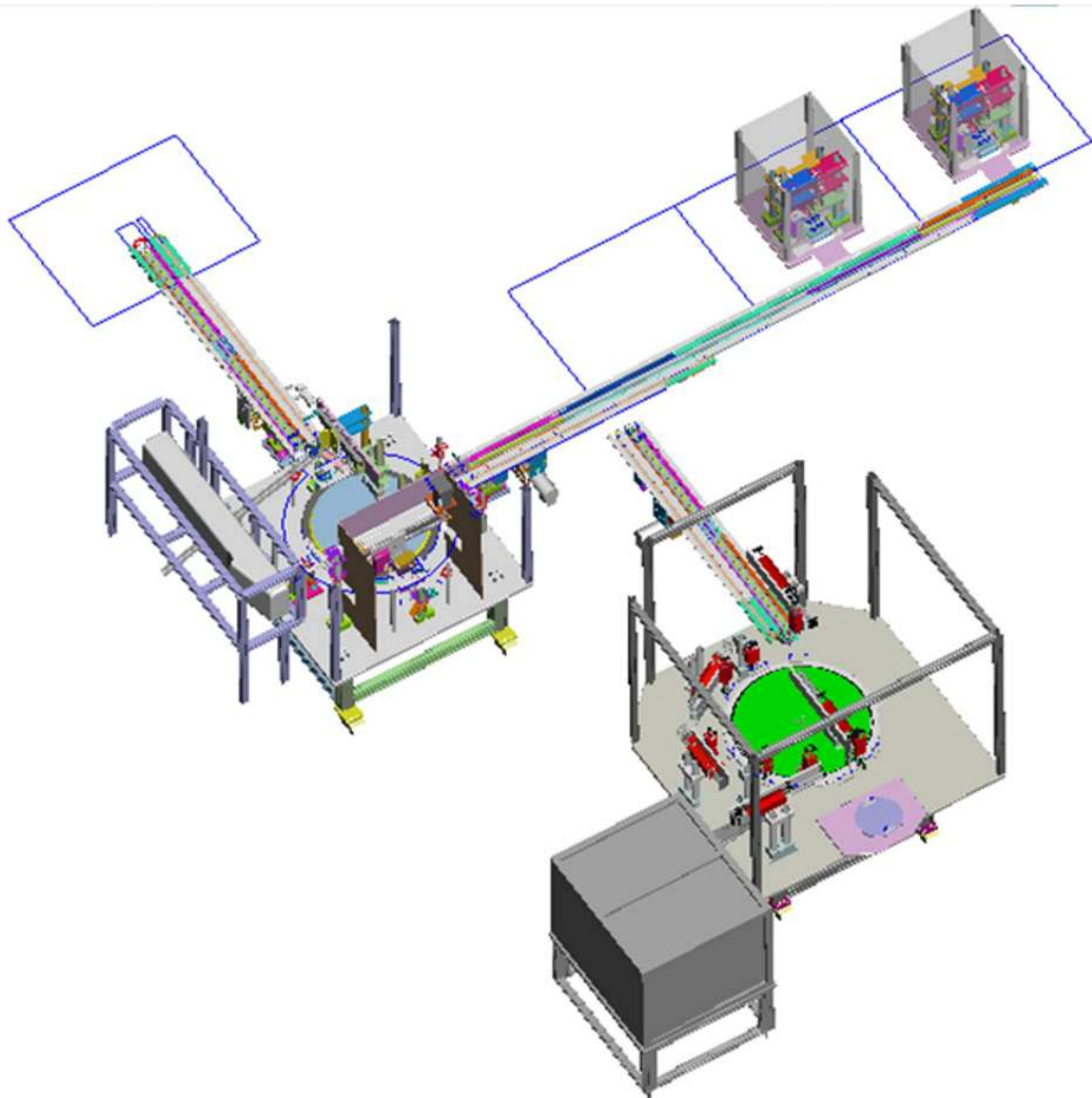

Fig. 14. A 3-D rendition of the proposed layout for Cell 1

A three-dimensional conceptual drawing of the proposed Cell 1 for this case study is given in Figure 14, and shows the two mechanized old three gang switch assembly jigs, the indexing table for single gang switch assembly, and the end of line testing module. The drawing for the proposed Cell 2 is given in Figure 15, and shows the indexing module for the assembly of the new three gang switches and the end of line testing module. These drawings were generated using Pro/ENGINEER (PTC, 2008).

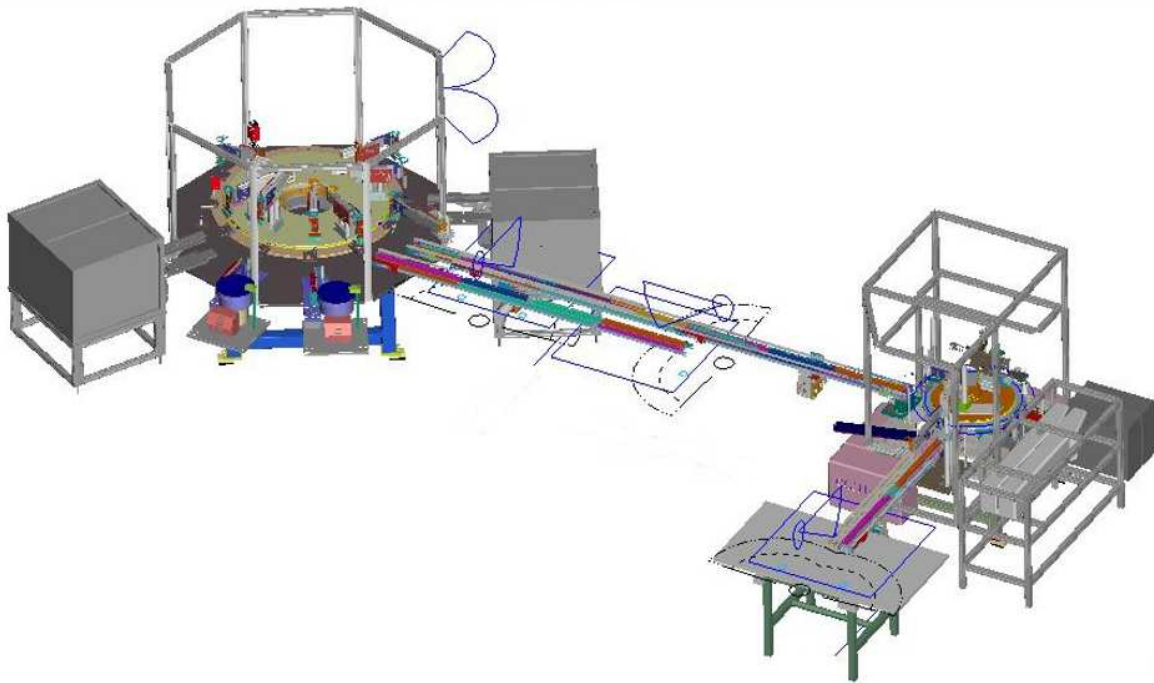

Fig. 15. A 3-D rendition of the proposed layout for Cell 2

6. Conclusion

The procedural guidelines that have been presented in this work contribute an important planning and implementation approach for the development of a conceptual design for a new manufacturing system, when migrating from manual to automated assembly of a part family of products. The novelty in the approach presented here is in the fusion of the conventional guidelines for the development of production automation systems, with a product design approach to the manufacturing system. The detailed case study that is presented in this work serves to demonstrate the application of the guidelines, and will serve as a useful reference tool for future projects of this nature. Future research in this area can include an extension of this approach to the embodiment and detailed design stages of the production system development.

In the case study it is shown that the new automated manufacturing system will result in a cycle time reduction of six seconds for the single gang switches, and of nine seconds for the new three gang switches. This will result in a corresponding increase in production capacity, thus also improving the flexibility of the company since it will be able to react to new customer orders more quickly. The new layout also results in a reduction in the manufacturing lead time, allowing the forecasted customer requirements to be catered for with over 40% excess capacity. The initial investment that is required is justified, since a significant reduction in labour costs is experienced, resulting in a return on investment of less than three years.

7. References

- Andreasen, M.M. & Hein, L. (1987). *Integrated Product Development*, IFS (Publications), ISBN 0948507217, Bedford, UK.
- Asfahl, C.R. (1992). *Robots and Manufacturing Automation* (Second Edition), John Wiley & Sons, Inc., ISBN 0471553913, NY, USA.
- Bahr, N.J. (1997) *System Safety Engineering and Risk Assessment: A Practical Approach*, CRC Press, ISBN 1560324163, London, UK.
- Baines, T. (2004). An integrated process for forming manufacturing technology acquisition decisions. *International Journal of Operations & Production Management*, Vol. 24, No. 5, pp. 447-467, ISSN 0144-3577.
- Boothroyd, G., Dewhurst, P. & Knight, W. (2001). *Product Design for Manufacture and Assembly* (Second Edition, Revised and Expanded), CRC Press, ISBN 082470584X, NY, USA.
- Chan, F.T.S & Abhary, K. (1996). Design and evaluation of automated cellular manufacturing systems with simulation modelling and AHP approach: a case study. *Integrated Manufacturing Systems* Vol. 7, No. 6, pp. 39-52, ISSN 0957-6061.
- Dieter, G.E. & Schmidt, L.C. (2009). *Engineering Design* (Fourth Edition), McGraw-Hill, ISBN 0072837039, NY, USA.
- Groover, M.P. (2001). *Automation, Production Systems, and Computer-Integrated Manufacturing* (Second Edition), Prentice-Hall, ISBN 0130889784, NJ, USA.
- Hyer, N. & Wemmerlov, U. (2002). *Reorganizing the Factory: Competing through Cellular Manufacturing*. Productivity Press, ISBN 1563272288, OR, USA.
- Kanawaty, G. (ed.) (1992). *Introduction to Work Study* (Fourth Edition), International Labour Organization, ISBN 9221071081, Geneva, Switzerland.
- Kapp, K.M. (1997). The USA Principle: The Key to ERP Implementation Success. *APICS~The Performance Advantage*, Vol. 12, pp. 62-66.
- PTC (2008). *Pro/ENGINEER design software*, Parametric Technology Corporation, MA, USA.
- Roozenburg, N.F.M. & Eekels, J. (1995). *Product Design: Fundamentals and Methods*, John Wiley & Sons, Inc., ISBN 0471954659, NY, USA.
- Säfsten, K., Winroth, M. & Stahre, J. (2007). The content and process of automation strategies. *International Journal of Production Economics*, Vol. 110, pp. 25-38, ISSN 0925-5273.
- Ullman, D.G. (1997). *The Mechanical Design Process*. McGraw-Hill, ISBN 0070657564, NY, USA.

- Winroth, M. & Säfsen, K. (2008). Automation Strategies - Implications on strategy process from refinement of manufacturing strategy content. *Proceedings of the 19th Annual Conference of the Production and Operations Management Society*, 008-0708, La Jolla, CA, USA, May 2008.
- Wojcikiewicz, K. (2003). Seven Key Factors for Ergonomic Workstation Design. *Manufacturing Engineering*, Vol.131, No.1, pp. 45-50.

IntechOpen

IntechOpen

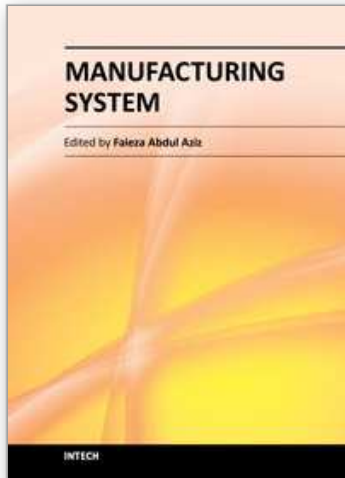

Manufacturing System

Edited by Dr. Faieza Abdul Aziz

ISBN 978-953-51-0530-5

Hard cover, 448 pages

Publisher InTech

Published online 16, May, 2012

Published in print edition May, 2012

This book attempts to bring together selected recent advances, tools, application and new ideas in manufacturing systems. Manufacturing system comprise of equipment, products, people, information, control and support functions for the competitive development to satisfy market needs. It provides a comprehensive collection of papers on the latest fundamental and applied industrial research. The book will be of great interest to those involved in manufacturing engineering, systems and management and those involved in manufacturing research.

How to reference

In order to correctly reference this scholarly work, feel free to copy and paste the following:

Michael A. Saliba and Anthony Caruana (2012). Migrating from Manual to Automated Assembly of a Product Family: Procedural Guidelines and a Case Study, Manufacturing System, Dr. Faieza Abdul Aziz (Ed.), ISBN: 978-953-51-0530-5, InTech, Available from: <http://www.intechopen.com/books/manufacturing-system/migrating-from-manual-to-automated-assembly-of-a-product-family-procedural-guidelines-and-a-case-stu>

INTECH
open science | open minds

InTech Europe

University Campus STeP Ri
Slavka Krautzeka 83/A
51000 Rijeka, Croatia
Phone: +385 (51) 770 447
Fax: +385 (51) 686 166
www.intechopen.com

InTech China

Unit 405, Office Block, Hotel Equatorial Shanghai
No.65, Yan An Road (West), Shanghai, 200040, China
中国上海市延安西路65号上海国际贵都大饭店办公楼405单元
Phone: +86-21-62489820
Fax: +86-21-62489821

© 2012 The Author(s). Licensee IntechOpen. This is an open access article distributed under the terms of the [Creative Commons Attribution 3.0 License](#), which permits unrestricted use, distribution, and reproduction in any medium, provided the original work is properly cited.

IntechOpen

IntechOpen