

We are IntechOpen, the world's leading publisher of Open Access books Built by scientists, for scientists

4,800

Open access books available

122,000

International authors and editors

135M

Downloads

Our authors are among the

154

Countries delivered to

TOP 1%

most cited scientists

12.2%

Contributors from top 500 universities



WEB OF SCIENCE™

Selection of our books indexed in the Book Citation Index
in Web of Science™ Core Collection (BKCI)

Interested in publishing with us?
Contact book.department@intechopen.com

Numbers displayed above are based on latest data collected.

For more information visit www.intechopen.com



Clean-Up and Decontamination of Hot-Cells From the IFIN-HH VVR-S Research Reactor

A. O. Pavelescu and M. Dragusin

*Horia Hulubei National Institute of Physics and Nuclear Engineering (IFIN-HH),
Bucharest-Măgurele,
Romania*

1. Introduction

The “Horia Hulubei” Institute of Physics and Nuclear Engineering VVR-S type research reactor from Magurele-Bucharest, Romania was shut down 13 years ago, in 1997, after 40 years of operation.

Radioisotope production generated a significant contamination in the reactor main building, ventilation system and radioactive leakage drainage, overflow and collecting system. Major radioactive contaminants generated by this activity, with the half life higher than one year, are: Co-60, Cs-134, Cs-137, Sr-90, Eu-152, U-238 and Am-241 [1].

Four hot cells, a transfer room, a chemical laboratory and a decontamination solution preparation room are placed in the basement of the reactor hall and were used for processing the radioactive materials coming from the reactor. The hot cells and the transfer room are disposed one next to another and the communication between them was performed through a transfer channel in which a transfer truck, carried materials inside the hot-cells. The VVR-S hot cells are highly contaminated and contain a lot of radioactive sources and activated materials. For this reason, this area is inaccessible and contamination measurements are not possible. The total activity of materials abandoned in these rooms it is not known, but it is expected to be of about 15 Ci (0.55 TBq). During the hot-cells decommissioning, these radioactive sources and materials will be evacuated.

The cleanup of the hot cells will be carried out under preservation license on the basis of an Activity Plan approved by Romanian National Commission of Nuclear Activities (CNCAN). IFIN-HH has an organizational structure in accordance with the Quality Management Program provisions for the activities developed inside the Institute. The reactor decommissioning department (DDR) includes a Quality Assurance Compartment (AC). The AC staff verifies the observance of the quality assurance conditions and the radiological security. The AC compartment reports to the IFIN-HH top management all the nonconformities related to the quality management systems and regarding the

radiological security requirements. All the members of the AC compartment are assigned with the CNCAN approval and are given responsibilities in accordance with the legislation in force.

2. General data necessary for the waste/material clean-up

2.1 Layout of the hot cells

The layout of the VVR-S research reactor hot cells is presented in the Fig. 1 below.

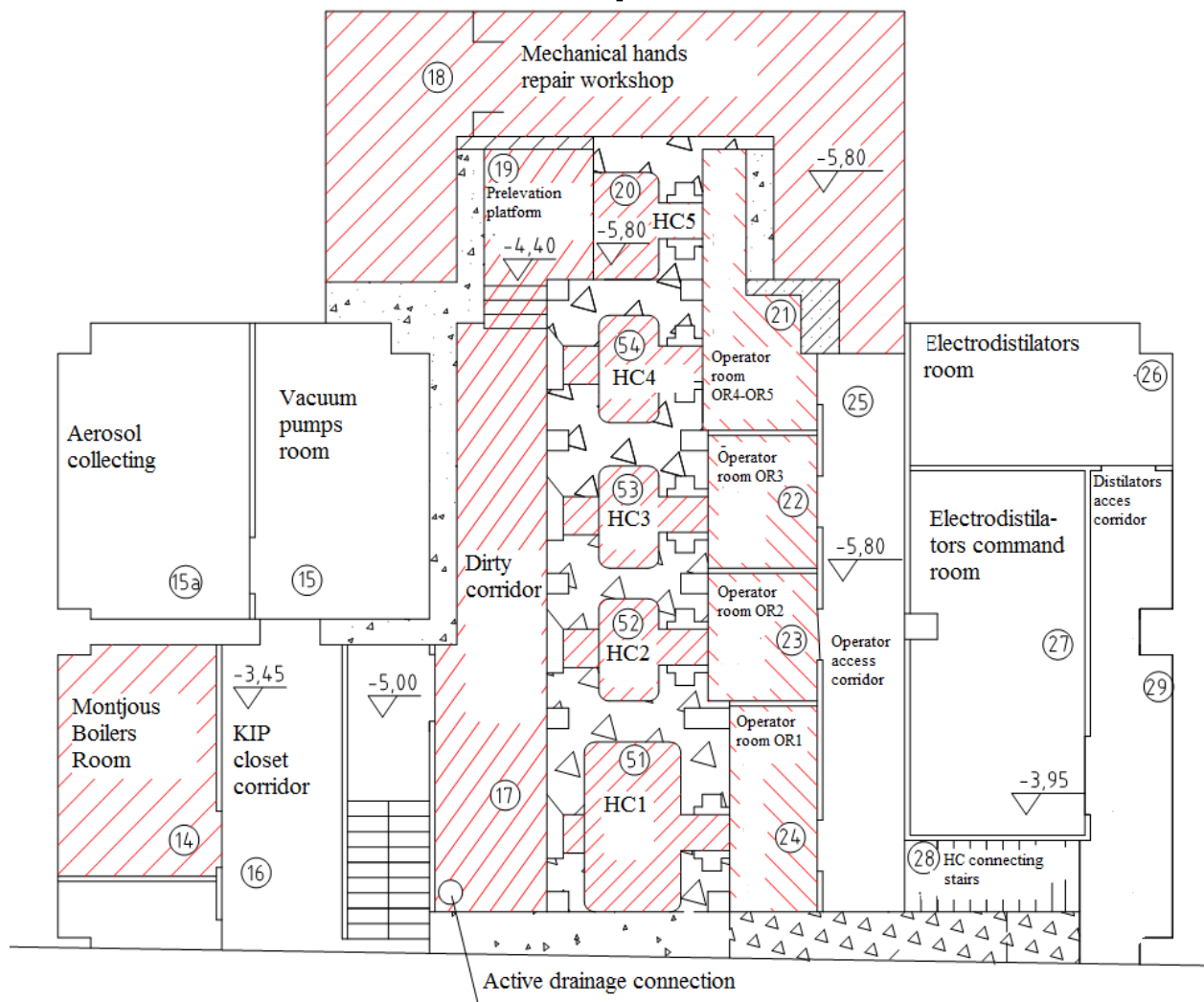

Fig. 1. The hot cells complex (HC1-HC5) [2]

Access to hot cells 1, 2, 3, 4 and 5 is made from the "dirty corridor" 17. Hot cell No. 1 (HC 1) has the following dimensions: length 3200 mm, width 2000 mm, height 3400 mm (2800 compartment without lamps). HC 1 can be accessed through a locked access corridors with a metal door (cast iron) having a thickness of 350 mm. Access corridors dimensions are: length 750 mm, width 900 mm, height 1600 mm. Hot cells 2, 3, 4 are identical in size and access, and have the dimensions of: length 2000 mm, width 1200 mm, height 2600 mm. (2000 mm without lamps compartment);

Access to HC 2, is made through a locked access corridors with a metal door (cast iron) having a thickness of 350 mm towards room 17 and a thin door (protection against contamination) of steel to hot room . Access corridors dimensions are: 1250 mm length mm, width 600 mm, height 1200 mm.

Access to HC3 or HC4 is made through identical in size corridors with the corridor for accessing the described HC2. Hot cells are fully clad with stainless steel sheet. For handling hot objects in the hot-cells mechanical arms are used, two for each room. Visibility is provided by the visor of Pb glass and lighting by lamps placed in separated niches in the ceiling.

Hot cells are ventilated on the inside (to ensure a depression of 5 mm H₂O from the outside). Hot air is discharged from the room through HEPA filters.

The HC 1 represented in Fig. 1 above, has the following dimensions: 2000 mm length, 1200 mm wide, 2600 mm height (2000 mm without the light compartment) [2]. The access in hot cell 4 (HC 4), is made by a closed metallic door from cast iron with a thickness of 350 mm towards room 17 and a thin door (for protection against contamination) made from stainless steel towards the hot cell. The access corridor dimensions are: 1250 mm length; 600 mm wide; 1200 mm height. The hot cells are entirely covered with stainless steel plate.

To calculate the biological shielding of the hot cells, it has been considered that the highest activity which one works with is 2.69×10^4 Ci (approx. 1 PBq) and the gamma radiation energy is 1.65 MeV. [2].

The biological shielding has the following characteristics [1]:

- The biological shield in the upper side is achieved through a 2 m concrete layer of 2.3 g/cm³ density and laterally through a concrete layer of 75 cm and a density of 4.2 g/cm³;
- Lead-glass eye-sleds, with 0.72 m of thickness;
- Between the hot cells, there are heavy concrete walls with 0.65 cm of thickness.

The radiological situation presented below is based on the hot-cell operating history described in an internal report made by the IFIN-HH Centre of Radioisotopes Production in 2003.

2.2 Hot-cells operating history

The VVR-S hot-cells operation history was used to approximate the contaminants in the HC interior and is presented in Table 1 [3].

Period	Operations	Sources Inventories
1957 - 1990	Production of radioisotopes for medical purposes, radiochemicals and various industrial applications (furnaces, measuring, etc)	Medical products: ^{131}I approx. 100 Ci/yr; ^{99}Mo approx. 50 Ci/yr; ^{198}Au approx. 50 Ci/yr; ^{192}Ir sources of SRC type approx. 1000 pc/yr x 50 mCi/pc = 50 Ci/an; ^{90}Y approx. 2Ci/yr; Radiochemicals: ^{82}Br approx. 2Ci/yr; ^{42}K approx. 4 Ci/yr; ^{32}P approx.3 Ci/yr; ^{35}S approx.300 mCi/yr, various radiochemicals: activities max. 5 Ci/yr; ^{60}Co sources for furnaces and other industrial applications, approx. 5 Ci/an
1970- 1983	Additional ^{192}Ir sources were produced for gammagraphy	^{192}Ir sources with activities of approx. 15 Ci - 20 Ci/source and total activities between 1000 Ci/yr and 8500 Ci/yr
1980-1985	Small uranium quantities have been irradiated for research purposes, while trying to perform fission molybdenum separation for obtaining ^{99}Mo - $^{99\text{m}}\text{Tc}$ generators	
01.01.1990 - 01.01.1998	Radionuclides were produced for medical and industrial use by irradiation of targets embedded in non-radioactive nuclear grade aluminum blocks with dimensions of 37 x 140 mm and 22 x 140 mm in wet canals.	Medical products: ^{131}I approx. 100 Ci/year; ^{99}Mo approx. 50 Ci/yr; ^{198}Au approx. 50 Ci/yr; sources ^{192}Ir type SRC approx.1000 pc/yr x 50 mCi/pc = 50 Ci/yr; Irradiated silicon for the electronics industry: between 10 and 30 blocks; Various radiochemicals, activity max. 5 Ci / year; ^{60}Co sources for furnaces and other industrial applications, activity approx. 2 Ci/yr.
01.01.1998 - 01.01.2003	Operations for the production of radioisotopes were not conducted.	

Table 1. Hot-cells operation history

2.3 Radiological situation

Existing estimated sources inventory in the VVR-S reactor hot-cells are given in Table 2 below [3]:

Hot cells	Inventory	Activity
Hot cell 1	In the existing deposit under the room worktop low activity sources of ^{60}Co may be found (this deposit has not been accessed since 1985); ^{60}Co small spheres, activity 1 Ci in 1997, respectively 0,5 Ci at 1.01.2003; ^{134}Cs 50 mCi in 1994, respectively 1.6 mCi in 2003.	
Hot cell 2	Approximately 1000 bars containing sources of ^{192}Ir , produced after 1983.	
Hot cell 3	Bottles with residual solutions of ^{60}Co , ^{134}Cs , ^{133}Ba , ^{63}Ni . Total activity may be around 50 mCi; Bottles containing fission production prepared in the period 1980-1982: ^{90}Sr , ^{137}Cs , ^{134}Cs . Total activity may be around 50 mCi; Plastic bag containing textile material used in decontamination, Plastic bag containing cellulosic material – filter paper, Irradiation box lead lest, Cotton mop, cylinder (filled) \varnothing 37 x 60 – possibly of Pb – counterweight; Empty can box without cap 800 ml, Stainless steel cylinders without cap \varnothing 25 x 70 empty, Plastic bag containing 2 bars probably with sources at their end; Mechanical hand tweezers	Estimated activities are: ^{60}Co – 30 mCi in irradiation boxes; 30 mCi in taps; 4 mCi in bars; ^{65}Zn – 7mCi in irradiation boxes; 7 mCi in caps; 1 mCi in irradiation bars.
Hot cell 4		The rest of generated radionuclides: ^{51}Cr , ^{59}Fe , ^{46}Sc , ^{140}La , ^{24}Na have most certainly decayed. Resulted residues from cutting the irradiation boxes contain the same radionuclides in quantities approx. 10 times smaller than the irradiation boxes. [3]
Hot cell 5	HC 5 is empty and presents no radiological risk.	
Hot cells 1-4	In all the HC there are also irradiation boxes as follows: Maximum no. of irradiation boxes 1500 boxes distributed in HC 1,2,3 and 4; 1500 taps and approximately 600 irradiations bars; An undetermined number of irradiation boxes and irradiation bars with uncut caps. Approx. 80 kg of Pb pellets of unknown isotopic composition are distributed in HC 1, 2 and 4 as well. [3]	

Table 2. VVR-S hot-cell sources inventory and activity

In HC 3 there are approximately 500 small paper baskets, approx.10 kg of glass, and approx. 2 kg of paper, as it can be seen in Fig. 2.



Fig. 2. Images through HC 3 visor. [4]

Due to the fact that it was open in 2006, HC 4 is the best characterized hot cell (Fig. 3 and Fig. 4).



Fig. 3. Images from the Operator Room No. 4 (OR 4) serving the HC 4 [4]



Fig. 4. Interior of the hot cell no. 4 (HC 4), opened in July 2006 [4]

The HC 4 measured dose rates are presented in Table 3

No.	Device	Detector	Measuring Location	Measuring Value
1	Eberline	Γ	Margins of opened exterior iron-cast protection door	42 $\mu\text{Sv/h}$
2	Eberline	Γ	Margins of plated interior door	280 $\mu\text{Sv/h}$
3	Eberline	Γ	Protection metal plate of the visitation window from transfer truck tunnel	200 $\mu\text{Sv/h}$
4	Eberline	γ	HC4 Centre at 0,5 m above the floor	1.4 mSv/h
5	Eberline	γ	HEPA filter level (near the filter)	0.7 mSv/h
6	Eberline	γ	Room Centre, floor level	9.2 mSv/h
7	Eberline	γ	Room centre, 1,5 m above floor level	0.3 mSv/h
8	Eberline	γ	Near floor drainage	4.4 mSv/h
9	Eberline	γ	Near the wall, left of the entrance	1.4 mSv/h
10	Eberline	γ	Middle waste tray. Probably the 2 bars from plastic bag contain sources	18 mSv/h

Table 3. Dose rate measurements in HC 4 in 24.07.2006 according to dosimetric service procedure AC-PO-DDR-501-01 [4]

The presumed total radionuclide inventory in 2003 is presented below in Table 4:

Radionuclide	$T_{1/2}$	Observations	Radionuclide	$T_{1/2}$	Observations
I-131	8.04 d	Fission product	Sr-90	29.1 y	Fission product
Mo-99	2.75 d	Fission product	Cs-137	30 y	Fission product
Au-198	2.69 d	Radioisotope	Zn-65	244 d	Radioisotope
Ir-192	74 d	Radioisotope	Cr-51	27.7d	Radioisotope
Y-90	2.62 d	Radioisotope	Fe-59	45.1 d	Radioisotope
Br-82	1.47 d	Radioisotope	Sc-46	83.8 d	Radioisotope
K-42	12.44 h	Radioisotope	La-140	1.68 d	Radioisotope
P-32	14.3 d	Radioisotope	Na-24	15 h	Radioisotope
Tc-99	6.02 h	Fission product	Co-60	5.27 y	Radioisotope
Cs-134	2.06 y	Fission product	Mo-99	2.75 d	Radioisotope
Ba-133	10.7 y	Radioisotope	Ni-63	96 y	Radioisotope

Table 4. Approximate contamination nuclide inventory and their half-life time in the hot-cells, reported in 2003, for the working activity cease in 1998 [4]

Dose rate in hot cells during and after their clean-up is currently unknown and an evaluation is presented in section 4.

3. Clean-up and decontamination activities for hot cell no. 4

3.1 Material transfer

The following activities will be accomplished in the following sequence [5]:

1. **Waste transfer from HC 4 to HC 5 and then to the conditioning containers or intermediate disposal.**

Transfer route: HV 4 → (direct connecting conduct between HC 4–HC 5, or HC 4 → connecting tunnel → DC 17 → Room 19 → HC 5 → HC 5 (preliminary measurement and containing) → lift-up in Room 102 (auto lock), containing in adequate barrels → Room 101 (NR hall quota 0,00 m) → Room 103 (radiological characterization of contained wastes) → Room 101 (NR hall quota 0,00 m) → room 102 (auto lock), expedition in to the treatment plant in view of conditioning or intermediate disposal.

2. **Identification/inventory of the evacuated wastes:** Wastes from HC4 are identified using photos obtained while opening HC4 from 24.07.2007 for measuring the dose rate.
3. **Measures in HC4** (in 24.07.2006 according to the dosimetry service AC-PO-DDR-501-01) [4]
4. **Evacuation of materials from HC 4** (for measuring the dose rate)

Using the direct connecting conduct from HC 4 and HC 5, the following operations are performed:

- a. The access door to the direct connecting conduct is opened from HC5 (room 20);
- b. Utilizing the mechanical hands from HC 4, the small wastes can be grasped then pushed through the inclined conduct towards HC5 in the following order as follows: plastic bag containing textile material used in decontamination, plastic bag containing cellulosic material – filter paper, irradiation box lead lest penal, cotton mop, cylinder (filled) \varnothing 37 x 60 – possibly of Pb – counterweight; empty can box without cap 800 ml, stainless steel cylinders without cap \varnothing 25 x 70 empty, plastic bag containing 2 bars probably with sources at their end; mechanical hand tweezers.

Wastes extracted one by one are measured with a dosimeter probe already installed in HC 5 in view of transfer in the adequate container.

NOTE: From the analysis of the dose rate measurement of 18 mSv on the waste tray, it is presumed that the greater dose is given by the plastic bag containing 2 bars probably with sources at the end on the respective tray. Before the evacuation of this bag, in HC 5, a lead container is let down from Room 102, which is adequate for disposal of this waste. The manipulation of the transferred wastes from HC 5 is made according to the operation procedure AC-PL-DDR-03. [6]

5. Opening the HC 5 doors

After the opening of doors from behind HC 5 the following operation take place:

- a. Opening of the biological protection door from HC 4 as follows:
 - The dose rate is measured and noted in the centre of the biological protection door opening, the centre of connecting tunnel with the HC4 contour and in the centre of interior protection door of the HC 4 (closed)

- The dose rate is measured at the surface in the centre of the protection plate of the carriage tunnel (on the floor)
 - Samples are taken and the contamination of the walls is analyzed, as well as the ceiling and the floor and of the ceiling of the HC4 connecting tunnel;
 - The HC 4 connecting tunnel interior surfaces are decontaminated. Non-fixed contamination is removed to prevent its transfers on the protection wearing or clothing. The decontamination is made by vacuum cleaner fitted with a HEPA filter, and the by cleaning with a wet cloths using organic solvents or with detergent and finally with water wet cloths for cleansing.
- b. Interior protection door is opened in HC 4 by sliding to the left as follows:
- Dose rate is measured and noted in the centre of the opened door, in the centre of the room, in the centre of the room, near various objects in the room.
 - Working time are calculated for manipulation operations of the radioactive wastes (the most active object)
 - Manipulation times are established in function of route distances, as well as the layout of the objects in the containers;
 - The operation will begin with the object having the greatest dose rate
- c. Transfer/evacuation of the wastes from HC 4
- From the operation room, with the aid of the mechanical hands the remaining objects are pushed one at a time, towards the centre of the room and in the access door of the HC 4, in such a way that the operator will not be forced to expose his body to the HC 4 interior;
 - The most active object is grabbed with the manipulator having the length of 1 meter. The object is taken out of the HC 4 and it is put in the prepared container, situated either in the connecting tunnel with HC 4, either in the corridor 17 near the biological protection door of the HC 4. The contained cover is mounted, the interior protection HC 4 door is closed and it is assured by sealing.
 - The container is transported in HC 5. From the HC 5 operator room, the object activity is measured. The manipulation of the devices found in the hot cells of the VVR-S nuclear reactor is made according to the AC-PL-DDR-03 procedure [6].
- d. The container is transported in the room 102, there it is loaded in an adequate barrel and it is transferred through hall 101 in room 103 in view of characterization and later transfer towards the Department of Radioactive Wastes Management, according to the operating procedure PO-DDR-827 [7].
- e. The steps from c), d) and e) are retaken until reaching the complete emptiness of the HC 4.

NOTE: Special working obligatory equipment is required as follows: sealed protection costume, resistant to water drops, with prepared air feeding and telephonic communication line. The operations are performed only with manipulators, pincers and homeostatic pincers for gripping, manipulation of the HC 4 objects. Operator will not expose his full body by entering the hot cell, in order to retrieve and process the objects inside.

3.2 Decontamination of the HC 4 interior

The following activities will be accomplished in the following sequence [5]:

- The dose rate in the completely empty HC 4 is measured;
- The working times are calculated for the scenario in which the operator exposes his full body by completely enter the room;
- The interior of the HC is decontaminated by washing with water and detergent jet, and then only with water jet utilizing the pressure equipment. Small fine water droplets are produced which can contaminate the protection costume and the HC 4 connecting tunnel;
- The decontamination solution is evacuated from HC 4 by removing the lid from the room drainage system (utilizing the manipulator). If the drainage is stuck, the decontamination solution is recovered by peristaltic pump (80 l/h) and it is spilled in the active drainage connection from corridor 17;
- When attaining an acceptable dose rate of 60-100 $\mu\text{Sv/day}$ measured in the centre of the room, the operator enters inside the HC 4 and the walls are decontaminated with a wet cloth with organic solvents, collecting the cloths in recipients situated at the beginning of the connecting tunnel.

3.3 Closing of the HC 4

The procedure is similar with the one for opening if HC 4, but in reverse order [5]:

- The HC 4 connecting tunnel door is closed;
- The radiation field is measured and recorded in the connecting tunnel from corridor 17 and HC 4;
- The biological protection door towards the corridor 17 is closed and sealed;
- Secondary wastes resulted from corridors 17, 19 and 20 (floors foils);
- The radiation field from the corridors 17, 19 and 20 is measured.

NOTE: After closing the HC 4 becomes clean and fully operational.

4. Dose/Risk modeling using RESRAD computer codes package

4.1 RESRAD Build 3.5 Code

RESRAD is a computer code designed to estimate radiation doses and risks from RESidual RADioactive materials (Fig. 5) [8]. The only code designated by Department Of Energy for the evaluation of radioactively contaminated sites.

United States National Regulatory Commission (NRC) has approved the use of RESRAD for dose evaluation by licensees involved in decommissioning, NRC staff evaluation of waste disposal requests and dose evaluation of sites being reviewed by NRC.

RESRAD has been applied to over 300 sites in the U.S. and other countries. Environmental Protection Agency (EPA) Science Advisory Board reviewed the RESRAD model. EPA used RESRAD in rule-making on radiation site cleanup regulations.

RESRAD code has been verified and has undergone several benchmarking analyses, and has been included in the IAEA's VAMP and BIOMOVs II codes to compare environmental transport models. RESRAD training workshops have been held at DOE, NRC, and EPA headquarters. Around 800 people have been trained at these workshops and RESRAD has been used by several universities as a teaching tool as well.

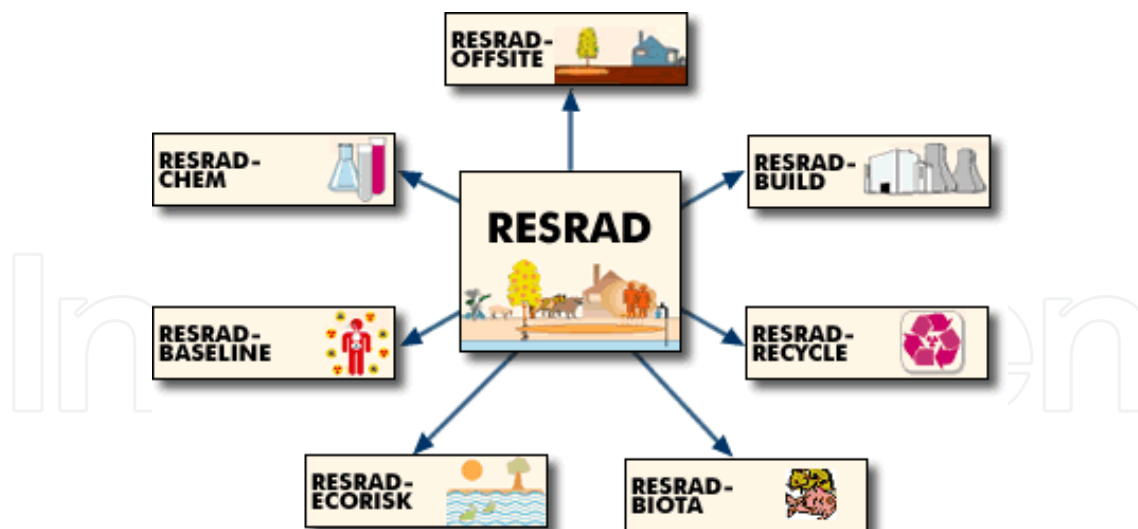

Fig. 5. RESRAD computer code package [8]

The RESRAD Build Code is a model for analyzing the radiological doses resulting from the remediation and occupancy of buildings contaminated with radioactive material with the following features (Fig. 6) [9]:

- Considers external exposure, inhalation of dust and radon, and ingestion of soil/dust.
- Up to 10 sources and 10 receptors can be modeled.
- Sources geometry can be point, line, plane, or volume.
- Building can be any structure composed of up to three compartments.
- Radioactive contamination can be on surface or in building material.
- Exposure scenarios considered include building occupancy (residential use and office worker) and building remediation (decontamination worker and building renovation worker).

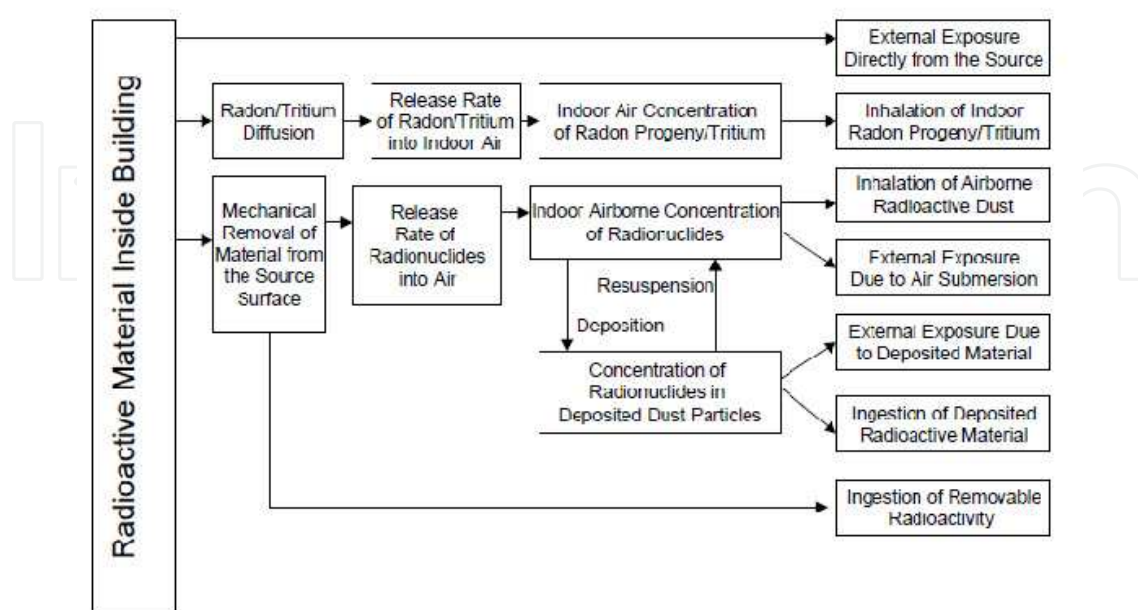

Fig. 6. Exposure Pathways Incorporated into the RESRAD-BUILD Computer Code [9]

Parameter	Unit	Building Occupancy ^a	Building Renovation ^b	Remarks
Exposure duration	days (d)	365.25	179.00	To match the occupancy period of 365.25 days in NUREG/CR-5512 building occupancy scenario (Beyeler et al. 1999 [8]) and renovation period of 179 days in NUREG/CR-5512 building renovation scenario (Wernig et al. 1999 [9]).
Indoor fraction	— ^c	0.267	0.351	To match the 97.5 d/yr time in building in NUREG/CR-5512 building occupancy scenario (Beyeler et al. 1999) and 62.83 days spent in the building during renovation period in NUREG/CR-5512 building renovation scenario (Wernig et al. 1999 [9]).
Receptor location	m	0, 0, 1	0, 0, 1	At 1-m from the center of the source.
Receptor inhalation rate	m ³ /d	33.6	38.4	For building occupancy scenario it matches with 1.4 m ³ /h breathing rates in NUREG/CR-5512 (Beyeler et al. 1999 [8]) and for building renovation scenario it matches with 1.6 m ³ /h breathing rate of moderate activity given in the EPA Exposure Factor Handbook (EPA 1997 [9]).
Receptor indirect ingestion rate	m ² /h	1.12x10 ⁻⁴	0	Value for the building occupancy scenario is the mean value from the distribution and for the building renovation scenario it is assumed the ingestion is only from the direct contact with the source.
Source type -	—	Area	Volume	For building occupancy scenario it is assumed that contamination is only on the surfaces, whereas for the building renovation scenario is volumetric

Parameter	Unit	Building Occupancy ^a	Building Renovation ^b	Remarks
Direct ingestion rate	1/h (area) g/h (volume)	3.06 × 10 ⁻⁶	0.052	Calculated from the default ingestion rate of 1.1 × 10 ⁻⁴ m ² /h in NUREG/CR-5512 building occupancy scenario (Beyeler et al. 1999 [8]). The effective transfer rate from NUREG/CR-5512 building renovation scenario for ingestion of loose dust to the hands and mouth during building renovation (Wernig et al. 1999 [9]).
Air release fraction	–	0.357	0.1	For the building occupancy scenario, it is the mean value from the parameter distribution. For the building renovation scenario, a smaller fraction is breathable.
Removable fraction	–	0.1	NR ^d	10% of the contamination is removable (NUREG/CR-5512 building occupancy scenario default [10]). The parameter is not required for the volume source.
Time for source removal or source lifetime	d	10,000	NR	Value for the building occupancy scenario is the most likely value from the parameter distribution. The parameter is not required for the volume source.
Source erosion rate	cm/d	NR	4.1 × 10 ⁻⁴	For the building renovation scenario, it is assumed that the total source thickness of 15 cm can be removed in 100 years of building life.

^a Parameter values used in the building occupancy scenario.

^b Parameter values used in the building renovation scenario.

^c A dash indicates that the parameter is dimensionless.

^d NR = parameter not required for the analysis.

Table 5. Key parameters used in the building occupancy and building renovation scenarios [10]

4.2 Calculation of the intake rates and time integrated cancer risks

RESRAD is able to calculate lifetime cancer risks resulting from radiation exposure. The radiation risk can be computed by using the U.S. Environmental Protection Agency (EPA) risk coefficients with the exposure rate (for the external radiation pathways) or the total intake amount (for internal exposure pathways).

The EPA risk coefficients are estimates of risk per unit of exposure to radiation or intake of radionuclides that use age- and sex-specific coefficients for individual organs, along with organ-specific dose conversion factors (DCF). The EPA risk coefficients are characterized as best-estimate values of the age-averaged lifetime excess cancer incidence risk or cancer fatality risk per unit of intake or exposure for the radionuclide of concern. Detailed information on the derivation of EPA risk coefficients and their application can be found in several EPA documents [11] [12]. The methodology used in the RESRAD code for estimating cancer risks follows the EPA risk assessment guidance (EPA 1997) and is presented very briefly in the following section.

Intake rates calculated by the RESRAD code are listed by radionuclide and pathway and correspond to specific times. Intake rates for inhalation and ingestion pathways are calculated first for all of the principal radionuclides and then multiplied by the risk coefficients to estimate cancer risks.

For inhalation and soil ingestion pathways ($p = 2$ and 8 , respectively), the intake rates (Bq/yr or pCi/yr) can be calculated by using the following Equation (1) [13]:

$$(Intake)_{j,p}(t) = \sum_{i=1}^M ETF_{j,p}(t) \times SF_{i,j}(t) \times S_i(0) \times BRF_{i,j}, \quad (1)$$

where:

$(Intake)_{j,p}(t)$ = intake rate of radionuclide j at time t (Bq/yr or pCi/yr),

M = the number of initially existent radionuclides,

$ETF_{j,p}(t)$ = environmental transport factor for radionuclide j at time t (g/yr),

p = primary index of pathway,

$SF_{ij}(t)$ = source factor,

i, j = index of radionuclide (i for the initially existent radionuclide and j for the radionuclides in the decay chain of radionuclide i),

$S_i(0)$ = initial soil concentration of radionuclide i at time 0 ,

The cancer risk at a certain time point from external exposure can be estimated directly by using the risk coefficients, which are the excess cancer risks per year of exposure per unit of soil concentration. Because the risk coefficients are derived on the basis of the assumptions that the contamination source is infinite both in depth and lateral extension and that there is no cover material on top of the contaminated soil, it is necessary to modify the risk coefficients with the cover and depth, shape, and area factors to reflect the actual conditions. Non-continuous exposure throughout a year also requires that the occupancy factor be considered when calculating the cancer risks.

Consequently, the RESRAD code uses the environmental transport factor for the external radiation pathway, along with the risk coefficient and exposure duration, to calculate the excess cancer risks as seen in Equation (2) [13]:

$$(\text{Cancerrisk})_{j,1}(t) = \sum_{i=1}^M ETF_{j,1}(t) \times SF_{ij}(t) \times S_i(O) \times BRF_{i,j} \times RC_{j,1} \times ED, \quad (2)$$

where:

$RC_{j,1}$ = risk coefficient for external radiation (risk/yr)/(pCi/g),

ED = exposure duration (30 yr).

For the inhalation and ingestion pathways, the cancer risks at a certain time point are calculated as the products of intake rates, risk coefficients, and exposure duration. Unlike the intake rates, cancer risks from inhalation of radon and its decay progeny are reported as total risks that include radon and progeny contributions. Therefore, the radon risks are the sums of the products of the individual radon or progeny intake rates and their risk coefficients.

4.3 Modeling results

In a previous study [14] the dose rate and the associated risk related to the clean-up and decontamination of HC 4 was evaluated. Using the measured doses, the activity of these sources and the associated risk was estimated, due to the difficulty of the spectroscopy analysis in order to determine the exact nuclide sources and their activity. The presumed time for clean-up and decontamination operation is 1 month for each hot cell, and therefore the estimation was made for this period. The dose rate and the associated risk related to the clean-up and decontamination of hot cell no. 4 were calculated using RESRAD Build 3.5 code.

In the model 1 receptor was considered and 3 nuclide sources were taken into account: Co-60, Cs-137, Sr-90, because these nuclides are most probable in the hot cells. The activity of these sources was estimated by using Rad Pro 3.26 software models [15], starting from the measured doses. This was done, due to the lack of a difficult to perform spectroscopy analysis (inside the hot cell) in order to determine the exact nuclide sources and their activity.

In Fig. 7, a graphic is presented, showing the evolution of modeled hourly dose rate at the beginning of the operations, then after 1, 2, 3 and 4 weeks of clean-up operations when only the external pathways are taken into account. At the beginning of clean-up operations, the calculation revealed an initial equivalent hourly dose rate of 7 mSv (700 mrem). The relative high dose rate is due to the fact that receptor was modeled without a biological lead protection. The dose decreases in time towards insignificant values, as the hot cell no. 4 is cleared and decontaminated [14].

As it can be seen in Fig. 8, in the unlikely scenario in which the exposure pathways are summed (inhalation, ingestion, immersion, external, deposition and radon) the equivalent dose rate becomes extremely high. The corresponding cancer risk, presented in Fig. 9, is

higher than 100 for this particular scenario. Due to high dose/risks involved, complying with ALARA principle, the utilization of a robot is proposed, instead of a human operator.

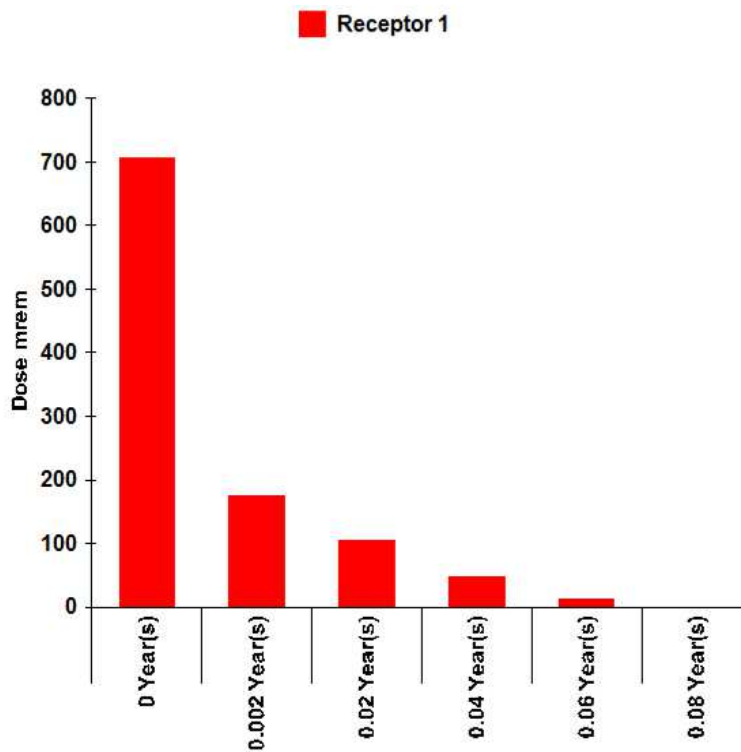

Fig. 7. Dose received by time for summed nuclides and external pathways [14]

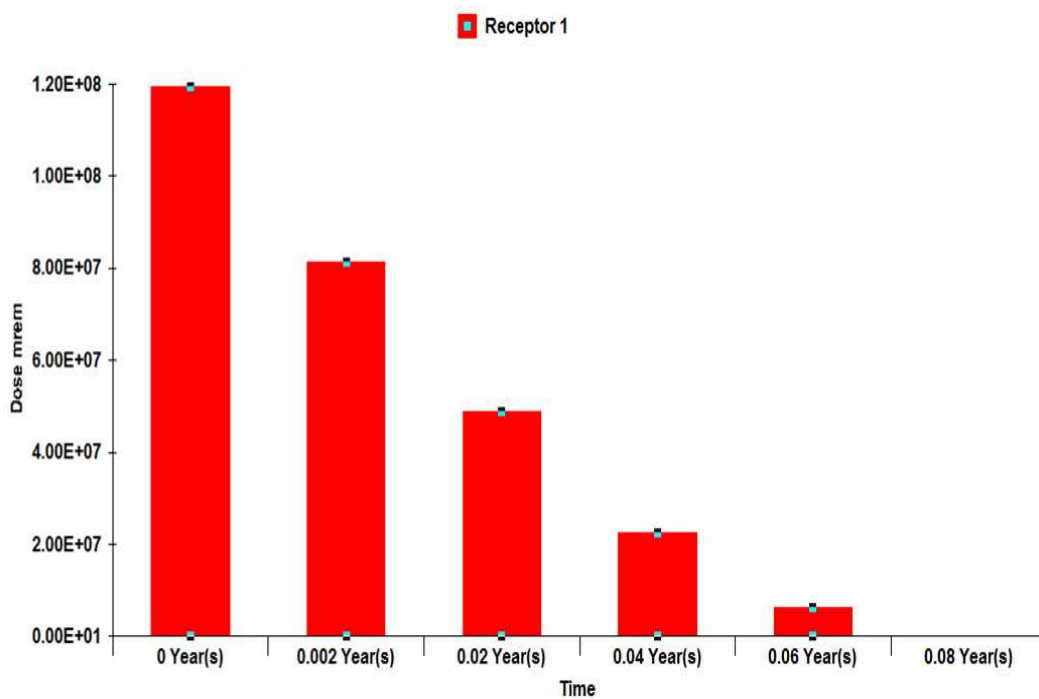

Fig. 8. Dose by time for summed nuclides, summed sources and summed pathways [14]

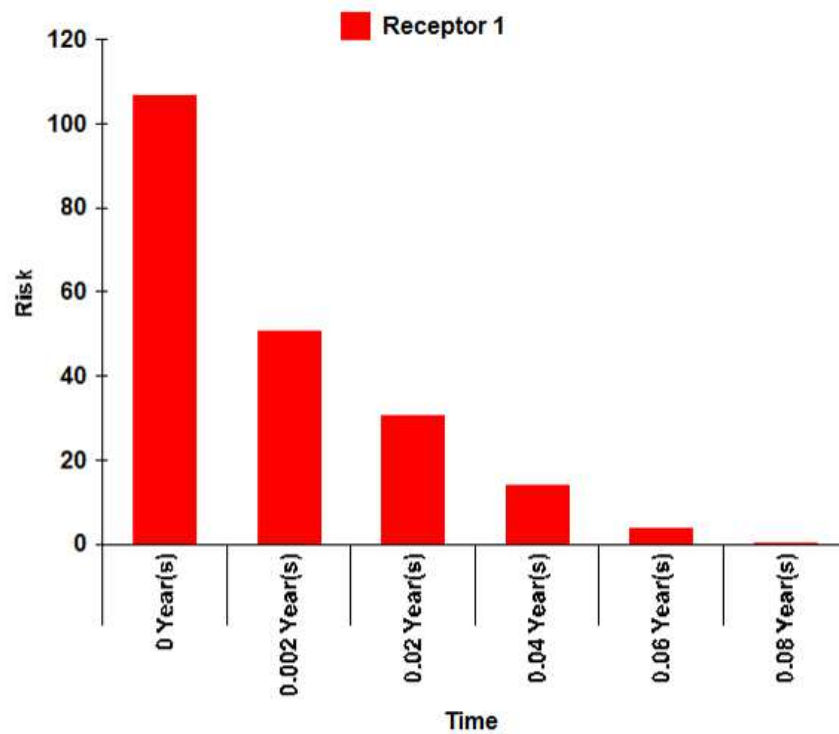

Fig. 9. Risk by time for summed nuclides, summed source and summed pathways. [14]

Furthermore, the modeling revealed each nuclide contribution to the overall risk. In the proposed reference scenario, the greatest risk is presented by Sr-90 followed by Cs-137 and Co-60 (see Figure 10) [14].

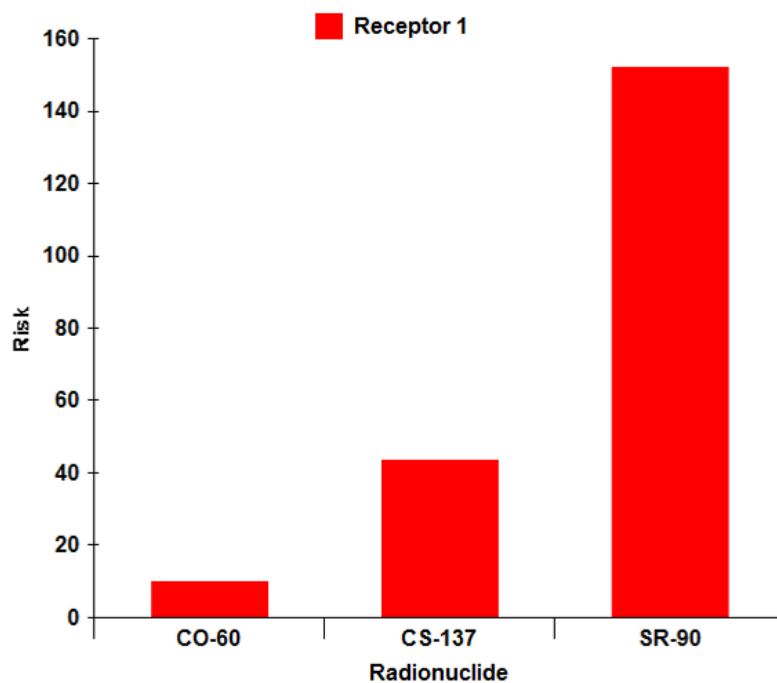

Fig. 10. Risk by each nuclide for the reference scenario [14]

In Fig. 11, the risk for all the exposure pathways is presented. At the beginning at the operations, both the risks from aerosols inhalation and ingestion are presented, then only the risk from ingestion remains high. This is due to the fact that the modeling did not take into account any breathing equipment for the operator. The risks from external exposure, deposition, immersion and radon are considerable smaller.

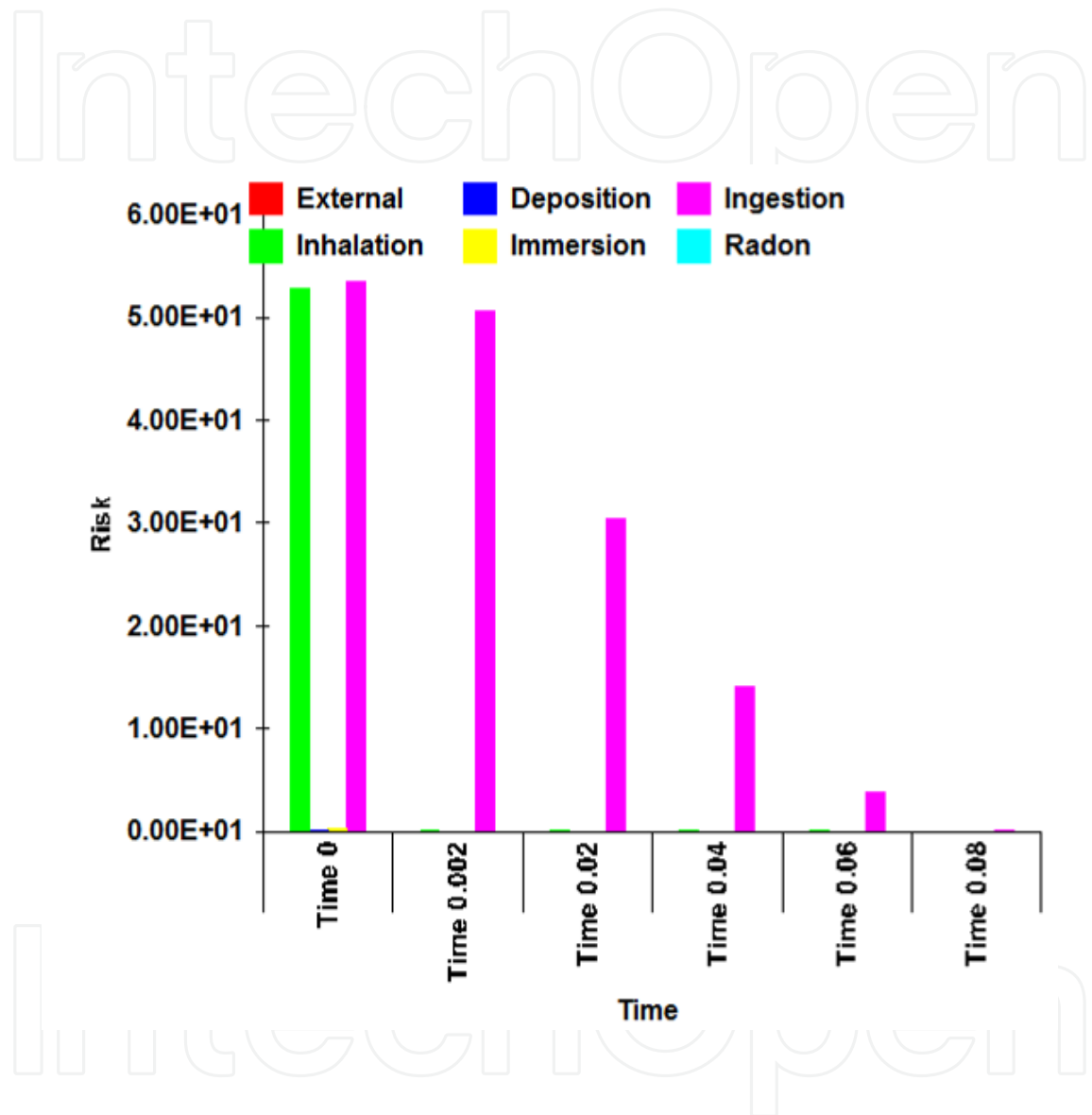

Fig. 11. Risk by time and pathway for summed nuclides and summed sources [14]

5. Remote operation alternative for clean-up and decontamination operations

Due to high dose/risks involved, complying with the ALARA principle, the utilization of a robot is proposed instead of a human operator. Using this robot, endowed with a high versatility arm (Fig. 12), the room will be cleared of remaining objects.

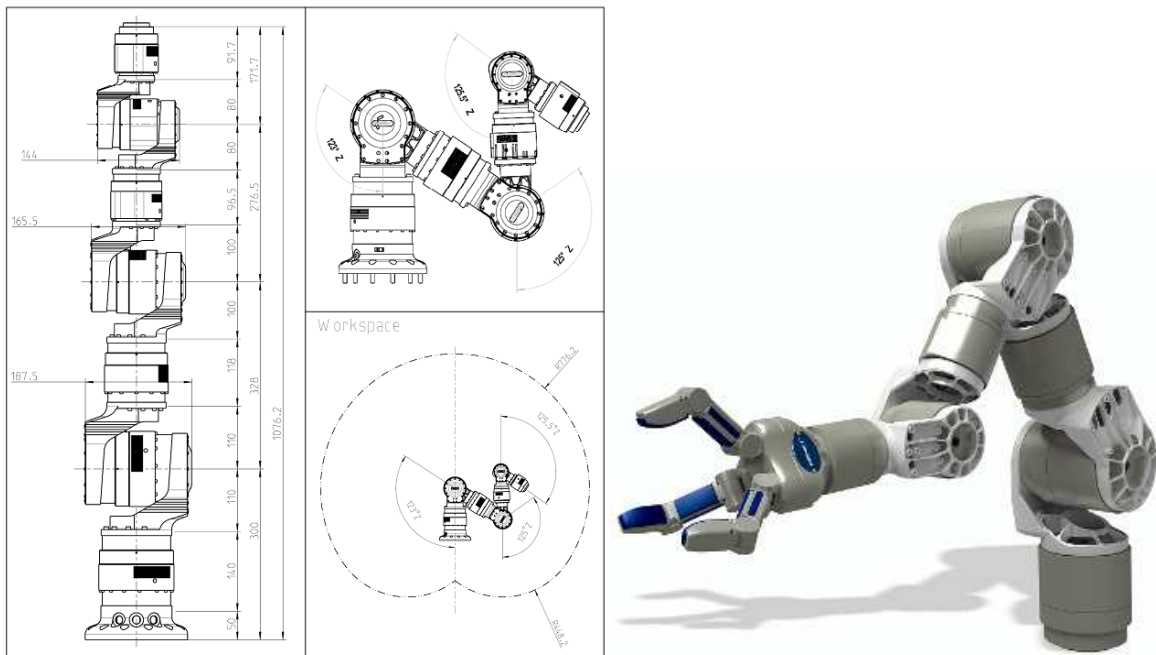

Fig. 12. Schunk robotic arm (a) [16]

The LWA 3 arm has the following features:

- Standard assembly of servo-electric swivel modules (PRL) and standard connecting elements to one 7-axis structure and 6 degree of freedom (2x PRL 120, 2x PRL 100, 2x PRL 80, 2x PRL 60);
- The arm can be configured in a reduced version with 5 modules and 4 degree of freedom;
- Nominal payload : 5 kg in standard configuration;
- Maximum payload: 10 kg in the reduced version;
- Arm length: 1073 mm (1.07 m) in standard configuration, but may be configured for longer reach by adding new actuator modules;
- When mounted on the MP-S500 Neobotix mobile platform (with a height of 0,59 m), the total height of the assembly, arm + platform, is approximately 1,40 m in normal functioning, but the arm can be folded in order to pass through the hot cell access tunnels (1.2 m of height);
- The IP protection class against penetration of water and foreign objects is 65. This represents a good protection and allows the decontamination with water jet, although the manufacturer does not recommend its utilization in extremely dirty environments;
- Completely interconnected cable routing through the hollow shaft integrated into the PRL-modules;
- Interconnected aluminum structure for weight optimization;
- Open software architecture for controlling the axes;
- Precision: 1 mm;
- Power supply 24 VDC / 20 A;
- Battery operation possible;
- Brushless servomotors

In Fig. 13 below, the Neobotix platform is shown and its dimensions are emphasized.

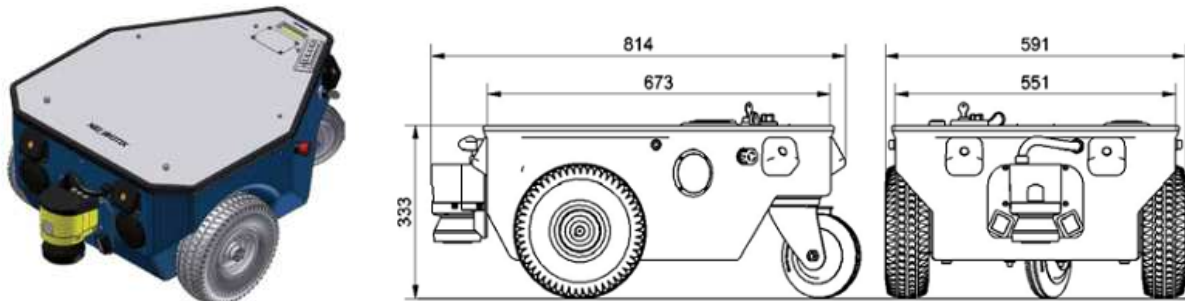

Fig. 13. Neobotix Platform [16]

Technical data for the Neobotix MP-S500 Platform:

- Dimensions (mm): 814 x 591 x 333(L x l x H);
- Weight: 80 kg;
- Payload: 80 kg;
- Moving speed: 1.5 m/s;
- Battery capacity: 10 h;
- Sensors: 1 x 2D laser sensor laser and 5x ultrasonic sensor;
- Control: external PC by wireless communication and onboard computer;
- The platform satisfies the maximum width criterion for accessing the hot cells doors of 600 mm, having a lateral dimension of 591 mm.



Fig. 14. Assembly of Schunk robotic arm mounted on the Neobotix Platform

In Fig. 14 above, the robot assembly is shown in standard configuration. Given its technical specifications and presented characteristics, the robot will be capable to perform all the decontamination operations, thus eliminating the need of a human operator.

6. Conclusion

The presumed time for clean-up and decontamination operation of Hot Cell 4 is 1 month. The modeling of the dose rate revealed an initial equivalent dose rate of 7 mSv and an associated cancer risk of 120, due to external exposure only, which subsequently decreases in time towards insignificant values, as the hot HC 4 is cleared and decontaminated. Furthermore, in the unlikely scenario that the exposure pathways are summed, the equivalent dose rate is extremely high. Nevertheless, in the proposed reference scenario the greatest risk is presented by Sr-90 followed by Cs-137 and Co-60. Due to high dose/risks involved, complying with ALARA principle, the utilization of a robot is proposed.

7. References

- [1] M. Dragusin, et al., *IFIN-HH VVR-S Research Reactor Decommissioning Plan, Revision 10*, Institute of Physics and Nuclear Engineering – Horia Hulubei (IFIN-HH), Centre of Decommissioning and Radioactive Waste Management (CDMR), February 2010;
- [2] M. Dragusin, A.O. Pavelescu, I. Iorga, *Good Practices In Decommissioning Planning And Pre-Decommissioning Activities For The Magurele VVR-S Nuclear Research Reactor*, Nuclear Technology & Radiation Protection Journal, ISSN 1452-8185, 2011;
- [3] IFIN-HH M. Sahagia et al, *VVR-S Research Reactor Hot-Cells Radiological Situation Report*, Institute of Physics and Nuclear Engineering – Horia Hulubei (IFIN-HH), Centre of Radioisotopes Production Report, 2003.
- [4] D. Stanga et. al, *Dose Rate Measurements in VVR-S Research Reactor Hot Cell No. 4*, Dosimetric Service Procedure AC-PO-DDR-501-01, 24.07.2006;
- [5] V. Popa, A.O. Pavelescu, et al., *IFIN-HH VVR-S Reactor Hot Cells Clean-up Plan (draft version)*, Institute of Physics and Nuclear Engineering – Horia Hulubei (IFIN-HH), 2011
- [6] V. Popa et al, *Manipulation of the Transferred Wastes from the VVR-S Reactor Radioactive Wastes Treatment Facility*, Institute of Physics and Nuclear Engineering – Horia Hulubei (IFIN-HH), Operation Procedure AC-PL-DDR-03, Revision 1/June 2006;
- [7] V. Popa, *Interface Between Department of Decommissioning of the Reactor and Department of Management of the Radioactive Wastes for the transfer of the radioactive wastes*, Institute of Physics and Nuclear Engineering – Horia Hulubei (IFIN-HH) Operating Procedure PO-DDR-827, Revision 2/October 2007;
- [8] C. Yu, A.J. Zielen, J.J. Cheng, D.J. LePoire, E. Gnanapragasam, S. Kamboj, J. Arnish, A. Wallo III, W.A. Williams, H. Peterson, *User's Manual for RESRAD Version 6*, Environmental Assessment Division, Argonne National Laboratory (ANL), ANL/EAD-4, July 2001;
- [9] C. Yu, D.J. LePoire, J.J. Cheng, E. Gnanapragasam, S. Kamboj, J. Arnish, B.M. Biwer, A.J. Zielen, W.A. Williams, A. Wallo III, H.T. Peterson, Jr., *User's Manual for RESRAD-BUILD Version 3*, Environmental Assessment Division, Argonne National Laboratory (ANL), ANL/EAD/03-1, June 2003;
- [10] B.M Biwer, et al., *Technical Basis for Calculating Radiation Doses for the Building Occupancy Scenario Using the Probabilistic RESRAD-BUILD 3.0 Code*, NUREG/CR-6755, ANL/EAD/TM/02-1, prepared by Argonne National Laboratory, Argonne, Ill., for Division of Systems Analysis and Regulatory Effectiveness, Office of Nuclear Regulatory Research, 2002;

- [11] U.S. Environmental Protection Agency, *Exposure Factor Handbook*, EPA/600/P-95/002Fa, Office of Research and Development, National Center for Environmental Assessment, 1997;
- [12] K.F. Eckerman, et al., *Cancer Risk Coefficients for Environmental Exposure to Radionuclides*, EPA 402-R-99-001, Federal Guidance Report No. 13, prepared by Oak Ridge National Laboratory, Oak Ridge, Tenn., for U.S. Environmental Protection Agency, Office of Radiation and Indoor Air, 1999;
- [13] S. Kamboj, et al., *Probabilistic Dose Analysis Using Parameter Distributions Developed for RESRAD and RESRAD-BUILD Codes*, NUREG/CR-6676, ANL/EAD/TM-89, prepared by Argonne National Laboratory, Argonne, Ill., for Division of Risk Analysis and Applications, Office of Nuclear Regulatory Research, U.S. Nuclear Regulatory Commission, May 2000;
- [14] A. O. Pavelescu, V. Popa, M. Drăgușin, *Modelling of the Dose Rates and Risks Arising from Hot-cells Clean-up Activities in the Decommissioning of the VVR-S Research Reactor*, Romanian Reports in Physics, Bucharest, Romania, No. 2/2012 (in press);
- [15] R. McGinnis, *Rad Pro Calculator 3.26 Software Site Online*, Massachusetts Institute of Technology, <http://www.radprocalculator.com/Index.aspx>, 2011;
- [16] Schunk GmbH & Co. Catalog Automation Highlights, *LWA3 Lightweight Arm Modular Robotic Specification Sheet*, 2009.

IntechOpen

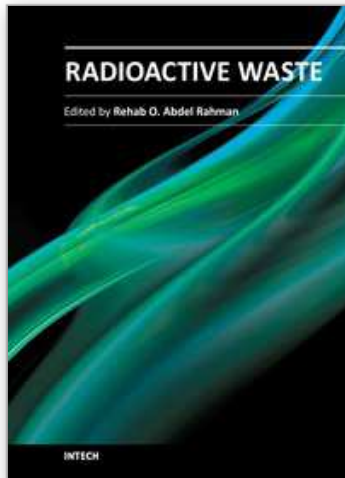

Radioactive Waste

Edited by Dr. Rehab Abdel Rahman

ISBN 978-953-51-0551-0

Hard cover, 502 pages

Publisher InTech

Published online 25, April, 2012

Published in print edition April, 2012

The safe management of nuclear and radioactive wastes is a subject that has recently received considerable recognition due to the huge volume of accumulative wastes and the increased public awareness of the hazards of these wastes. This book aims to cover the practice and research efforts that are currently conducted to deal with the technical difficulties in different radioactive waste management activities and to introduce to the non-technical factors that can affect the management practice. The collective contribution of esteemed international experts has covered the science and technology of different management activities. The authors have introduced to the management system, illustrate how old management practices and radioactive accident can affect the environment and summarize the knowledge gained from current management practice and results of research efforts for using some innovative technologies in both pre-disposal and disposal activities.

How to reference

In order to correctly reference this scholarly work, feel free to copy and paste the following:

A. O. Pavelescu and M. Dragusin (2012). Clean-Up and Decontamination of Hot-Cells From the IFIN-HH VVR-S Research Reactor, *Radioactive Waste*, Dr. Rehab Abdel Rahman (Ed.), ISBN: 978-953-51-0551-0, InTech, Available from: <http://www.intechopen.com/books/radioactive-waste/clean-up-and-decontamination-of-hot-cells-from-the-ifin-hh-vvr-s-research-reactor>

INTECH
open science | open minds

InTech Europe

University Campus STeP Ri
Slavka Krautzeka 83/A
51000 Rijeka, Croatia
Phone: +385 (51) 770 447
Fax: +385 (51) 686 166
www.intechopen.com

InTech China

Unit 405, Office Block, Hotel Equatorial Shanghai
No.65, Yan An Road (West), Shanghai, 200040, China
中国上海市延安西路65号上海国际贵都大饭店办公楼405单元
Phone: +86-21-62489820
Fax: +86-21-62489821

© 2012 The Author(s). Licensee IntechOpen. This is an open access article distributed under the terms of the [Creative Commons Attribution 3.0 License](#), which permits unrestricted use, distribution, and reproduction in any medium, provided the original work is properly cited.

IntechOpen

IntechOpen