

We are IntechOpen, the world's leading publisher of Open Access books Built by scientists, for scientists

4,800

Open access books available

122,000

International authors and editors

135M

Downloads

Our authors are among the

154

Countries delivered to

TOP 1%

most cited scientists

12.2%

Contributors from top 500 universities



WEB OF SCIENCE™

Selection of our books indexed in the Book Citation Index
in Web of Science™ Core Collection (BKCI)

Interested in publishing with us?
Contact book.department@intechopen.com

Numbers displayed above are based on latest data collected.

For more information visit www.intechopen.com



MSpace: An Emergent Approach, Modelling and Exploring Mutable Business-Entities

Mohamed Dbouk^{1*}, Hamid Mcheick² and Ihab Sbeity¹

¹Lebanese University, Faculty of Sciences (I), Beirut

²Université du Québec à Chicoutimi, Québec,

¹Lebanon

²Canada

1. Introduction

Things evolve and change states, e.g. a human being may have *Single* as social state, and may become *married*, *divorced*, etc., an employee may become *manager*, *president*, etc. software, databases, etc., may evolve as well, everything evolve.

Roughly speaking, in the literature object's or agent's evolutions are usually handled using objects/agents moving models and multi-dimensional representation. Most of traditional and powerful analytical systems prefer using multi-dimensional data structure that facilitating data/object representation and tracking. Those systems became popular in companies and industries that store and interpret historical information for decision-making purposes, e.g. data warehousing.

Dealing with unconventional and evolutive space is hard to undertake and reveal great challenges. Day by day, reactive and dynamic data are more and more pointed and solicited. This data may incorporate and stimulate huge amount of knowledge. In this context, the advance in technology, multidimensional analysis and business intelligent analysis are solicited more and more.

Traditional multidimensional approaches are almost concerned with historical cumulative data that constructed from the heap of *ETLed* (*Extracted, Transformed and Loaded*) data. The popular related technologies such as, data warehousing, data mining and On-Line Analytic Processing (OLAP) are key factors in the interactive analysis of large amounts of data-sets. These technologies are datasets-oriented and seem not enough flexible to deal with evolutive and mutable space, and not to consider a single record (entity) and exploring it along dimensions. Furthermore, existing approaches usually use offline copies of data, and sometimes this data may conflict and may give unexpected and inaccurate results. All of these feedbacks were the reason behind thinking about new approach.

Practically, concepts of evolutive space may reside in several kinds of real world business activities; the following examples meet our early approach [Dbouk & Sbeity 2009]:

*Corresponding author

Typical cases -Environmental related issues: risk management; flooding, forest (trees, etc.) evolutions, administering and monitoring agricultural practices, etc.

Educational monitoring and tracking: here we talk, for example, about the educational policies within a private university or within the entire country (ministry of education). Students and their activities are subject of investigation and analysis.

Site /City histories: modern city, archaeological site, construction site, volcanic site, etc., may have continuous stories and histories (images, video, maps, etc.); they evolve continually against key-features such as time and civilizations. Such information could be recorded and archived; it may become critical and useful for a certain application domains, e.g. Tourism.

Enterprise productivity inspection and tracking: in order to improve productivity, enterprises elaborate strategies and executive plans; they apply some kind of business intelligent human resource tracking. People (employees) within the enterprise could evolve by years and become more experimented and productive. Employees indeed could follow some policies and elaborated schemes.

Marine navigation tracking: merchant ships are for example considered as moving entities following pre-elaborated/evolutive trajectories. Ships may be equipped with dedicated materials and tools. Consequently, trajectories may be correlated / adjusted according to instantaneous and punctual analysis.

Biomedical treatments and experiments, etc...

The ultimate goal of the approach called "MSpace", that we propose, is to enable entity (individual space's element) evolution tracking and monitoring. We are going in this approach to elaborate a tool with OLTP and OLAP double roles and responsibilities, leading to analyse business entities' histories, managing entities' transitions and interactions between each other, observe and track current and up-to-date business entities' states in a multi-aspect/dimensional space, etc. The duty is to predict, direct and ultimately correlate entities' behaviours and any new and future activities.

To conclude, the approach, which we work on, represents a long research project, related models and tools are under elaboration and validation by referring to BI-like technologies and using Microsoft and Java platforms.

The rest of the chapter is organized as follows: in section 2 an overview of related works is discussed, and then the *ancestor approach* of MSpace is highlighted in section 3. In section 4, MSpace foundations and basis as well as software solution are established and deeply considered. Also, prototyping and validation issues are presented in this section. Finally, the outlines of future directions and conclusion are drawn in section 5.

2. Background and related works

The coming years will witness an important mass of on-line technologies, that use internet and satellite to find locations on Earth, example GPS (Global Position system), which depends on moving objects, location and time based multi-dimensional database to analysis and interpret geographical data. Here is the importance of dealing with moving

objects dedicated databases that store the object attributes in addition to its location and time dimensions. There are many researches in this domain, for example: FuMMO [Praing & Schneider, 2007a] model that working with geo-features, Balloon [Praing & Schneider, 2007b] model for keep of tracking both historical and future moving-objects. In their work Praing & Schneider “are especially interested in the design of data models for continuously changing geometric objects over time, typically known as moving objects”. Other geo-spatial model are reported, e.g. the land use model [Hammam et al., 2004], and the dynamic three-dimensional marine data model based on time series multi-surfaces [Zhang et al., 2007].

The moving objects data model “Balloon” deals with spatiotemporal changes; it provides an integrated support for both historical and future movements of moving objects. In contrast to basic “FuMMO” model [Praing & Schneider, 2007a] that working with low level object geo-features, “Balloon” [Praing & Schneider, 2007b] states for emerging both historical and future moving-objects’ movements. It seems well made and may influence future efforts in the area. “Hermes” [Pelekis et al. 2006] deals with dynamic objects that change locations, shape and size, either discretely or continuously over time. Whereas [Erwig et al., 1999] rather than dealing with geometries changing over time and traditional dimensions, it invests in higher-dimensional entities where structures and behaviours are captured and considered as abstract data types. Besides, the emerging multidimensional spatiotemporal approach presented in [Pestana & da Silva, 2005] promotes spatial analysis, and applies narrowly the key concept of evolution specifications.

Otherwise, a land use model is presented in [Hammam et al., 2004], the author presents a new technique called “vector agent based simulation”, which uses discrete irregular objects as an autonomous spatial entity beneath an agent modelling structure. Through computer simulation, this new technique has been applied to von Thunen’s theory of agricultural land use as a hypothetical environment for model verification. The findings demonstrate that this proposal can be considered as a new paradigm for urban simulation. The model will be strengthened and examined using the basic elements of Cellular Automata: space, neighbourhood, and transition rules, state, and time. Here the author considers *the world as a serious of entities located in space*. Entities are usually an abstraction of the real world. An autonomous active object or agent is a digital representation of all part of an entity. In this model, the transition rules specify the behaviour of cells between time-step evolutions, deciding the future conditions of cells based on a set of fixed rules. However, the state of the object changes is based on the adaptation of an entity to its environment by the process of differentiation and increasing shape structure complexity. Also the time variant is considered as an element in this approach, in each entity lifespan, changes occur describing the evolution of its inner existence, or a mutation of its location in space. The model implements two time modes: synchronous and asynchronous.

Also, a marine navigation tracking mode is reported in [Zhang et al., 2007]. Here, the Ocean is multidimensional and dynamic in spatial-temporal structure, and effective marine data modelling and representing of marine multidimensional geographic information system is a new hot topic and challenge. Zhang proposes a new dynamic real three-dimensional marine data model based on time series multi-surfaces. It utilizes various surfaces to model different marine water bodies and creates three-dimensional topologic relations of objects in

marine environments, then uses time series snapshots to delineate dynamic changes. The model is tested in safety estimation of navigation and motion of marine objects, and proved to be effective for the ship navigation.

GOLD model [Trujillo et al., 1999] was the base in pattern based multi-dimensional analysis. This model is an object oriented multi-dimensional data model, aims to identify of patterns based on the relationships between the dimensions attributes included in cube classes. These patterns will associate data together with OLAP operations and will allow us to have a concise execution model that maps every pattern of modelling into its corresponding implementation making users able to accomplish OLAP operations on cube classes.

As a result, based on “MSpace is an emergent approach” and in contrast with its intended goals, the above survey leads to conclude that each of these approaches and models shares basic concepts and foundations with MSpace; dynamic and or moving objects that change locations, multidimensional and spatial-temporal modelling, and pattern based multi-dimensional analysis, etc.

Strictly speaking, MSpace inherits basic ideas from our early GeoSEMA [Dbouk & Sbeity 2009], it indeed differs from this old approach (next section) by introducing the concept of multi-state business entities, and second, by applying a multidimensional modeling and analysis. Entities in MSpace, rather than temporal and the mobile (location-based) characteristics, they evolve in well organized behaviours. MSpace deals with contextual patterns (business profiles), in which dimensions are combined.

Finally, MSpace discusses and investigates research issues and advance solutions for modelling and exploring mutable and evolutive entities.

3. “GeoSEMA” the early approach

Our previous and early approach GeoSEMA [Dbouk & Sbeity 2009] is a conceptual platform dedicated to model a geospatial and evolutive space; it tends to emerge multidimensional and unconventional *geospatial* data.

Basically, GeoSEMA is interested in three principles: Space-environment characteristics, a classified set of geospatial evolutive mobile agents and a set of rules that governing and materializing the inter-agent interactions (extra-events). The considered geospatial space is seen as an unusual agent that grouping, collecting, associating, and coordinating a huge amount of unconventional geospatial agents.

Agents are expected to move, navigate, interact, etc. agents’ behaviors reflect and/or materialize external events.

GeoSEMA initiative is intended to deal with evolutive agents; reported concepts are basic and seem to be a firm foundation, they are considered as starting point for the MSpace approach. GeoSEMA tries indeed to be generic; it doesn't specialized in how moving-mobile objects should be handled, it pleads for predicted trajectories and deals with evolved objects/agents and emerges fundamental concepts issued by [Pestana & da Silva, 2005].

Due to the key-concepts issued in this work: multi-aspect/dimensional, multi-state and transitional entities, MSpace rather than emerging the GeoSEMA key- features, it also

incorporates both mutability (state-based dimensions) and mobility (location related dimensions or aspect) foundations.

4. “MSpace” a smart approach

The approach consists of an integrated tool tending to model and explore an evolutive and mutable well organized space. MSpace should answer the following questions:

- Mutable or evolutive space; what does this mean?
- Why dealing with so-called evolutive/mutable business entities?
- Mutable/evolutive business entities; what does mean?
- How the evolutive concept could be outlined, achieved, etc.?
- Aspects / dimensions, entity states; what does this mean?
- And finally, how entity’s transitions could be directed and how "pattern-based analysis" could help?

4.1 Basis and foundations

The space that we consider deals with unconventional schemes; it emerges multidimensional and unconventional data, it mainly consists of:

- a collection of mutable entities (business entities),
- a set of structural features (aspects/dimensions),
- set of behavioral features (transitions, business rules).

Business Entity (BE) – we introduce, in this approach, the concept of dynamic and mutable Business Entities. Entities are evolutive, multi-aspect (multidimensional), and multi-state; entities are reactive, move and transit constantly from one state to another state.

Business Entities are, basically, named one by one and should have two kinds of information (figure 1):

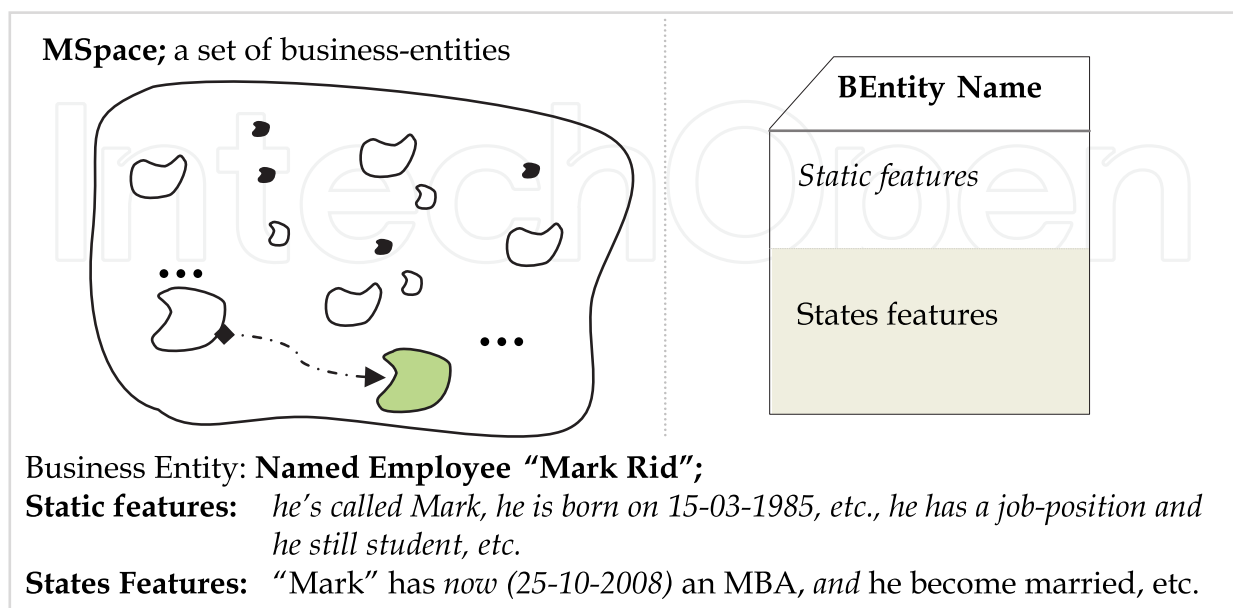

Fig. 1. MSpace basis

- Typical *static features*, e.g. name, date, etc. Those descriptive features usually have no direct effects on the entity state itself.
- A multiple *state-oriented key-features* recapitalize the entity reactions and behaviors, e.g. "Mark got, by 10/07/2007, a degree in Computer-Science". Those features should constantly be typified and well measured reflecting and characterizing entity related aspects (multidimensional concept).

Business Aspect – also called business dimension (practical vocabulary), it reflects and materializes our theory of evolutive and mutable space and entities. An aspect characterizes the space itself, it represents one face (entity-state) of the considered entities (figure 1; States Features); it consists of a collection of typified valuable indicators (sequences and or dispersed **values/intervals**). E.g. in the human resource management context, "Education; in terms of degrees" as well as "Civil State; in terms of single, married, etc", etc., may act as business aspects.

Briefly, identifying/specifying aspects represent a major job during the space modelling phase. Entities should be assigned multiple aspects. Entity by entity should from time to time picks indicators/values related to the considered aspects; towards the concept of "multi-state entity".

Business Transitions, Entity States – entities are intended to evolve and change valued-characteristics over time, they transit with respect to the pre-designated dimensions (above aspects). Business transitions are timed and dated. We depict two main types *locale* (aspect-based, figure 2,3) and *global* (profile-based, figure 4) that materializing some external event and or entity-state re-evaluation, e.g. "Mark gets married", "Mark gets new job position, he may became *manager*, etc."

- **Local Transition** occurs (by some way) when a business entity is incited to get a new position/value from those of the considered dimension (aspect-based; $\tau_{\text{aspect,time}}$). E.g. "Mark gets a PhD in 14-09-2011"; the event/transition is made by an external institute at a specific time/date (figure 2, 3).
- **Primary-Sate**; as a result of a local transition, the entity gets a new business state called, also, "Primary-Sate". The Sequence of those primary-states (combining local-transitions, figure 2, 3) forms the true evolution scenario and story for the considered entity.

Formally: $BE_{ij} = \tau_{ij}(BE_{ij-1})$

BE_{ij} : **primary-state** on "i", result of transition τ_j on the previous entity-state " BE_{ij-1} ".

τ_j : a **local transition** on aspect i and time j; allocating a new value to the adequate entity's feature.

"i" represents a specific aspect (dimension; "Dim-I").

BE evolution-scenario: $\pi_{i,k}(BE) = \tau_{ik} \circ \tau_{ik-1} \circ \dots \circ \tau_{ij-1} \circ \tau_{ij} \tau_{ij+1} \circ \dots \circ \tau_{i1}(BE_{i0})$

- **Total-states and Business-Profiles**; A Total-Sate is formed by putting together primary-states one by one and one by aspect, e.g. $\langle BE_{1i}, BE_{22} \dots BE_{ni} \rangle$ (figure 4). Theoretically, huge amount of states could be generated; only some of them may form a useful and coherent collection. Those collections should be appointed and gave business names, useful states will represent that we call "Business-Profiles"; toward business pattern-based prediction and analysis.

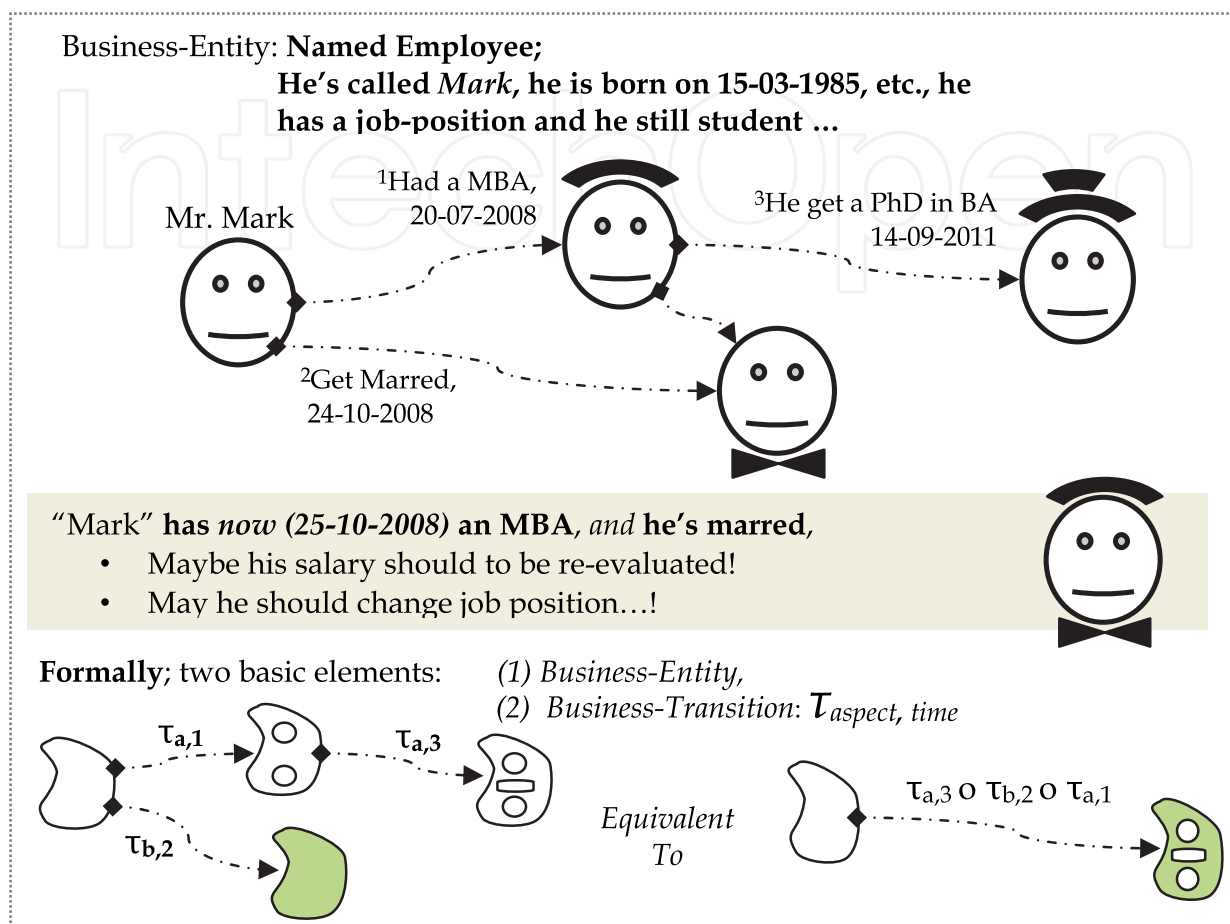

Fig. 2. Business-Transition basis

BE Total-State is “n-pstates” (**primary states**), it is a combination of type $\langle BE_{11}, BE_{2j}, \dots, BE_{ij}, \dots, BE_{nk} \rangle$, where:

“1, 2, ..., i, ..., n” indicate the space dimensions (aspects). BE_{ij} : represents a BE primary-state (pstate) over “i” (figure 3).

BE Business-Profile is a named BE Total-State or more general, it looks like: $\langle SA_1, SA_2, \dots, SA_i, \dots, SA_n \rangle$, where SA_i represents an arrangement (a set) of designated positions (valuable as primary-states) on aspect “i”. e.g. $\langle BE_{13}, \{BE_{22}, BE_{23}, BE_{28}\}, \dots, [BE_{ik}, BE_{ik+4}], \dots, BE_{nm} \rangle$.

A Business-Profile may incorporate a set of useful Total-States. E.g. $\langle BE_{12}, BE_{2j}, \dots, \{BE_{ij}, BE_{i2}\}, \dots, BE_{n2} \rangle$ incorporates both $\langle BE_{12}, BE_{2j}, \dots, BE_{ij}, \dots, BE_{n2} \rangle$ and $\langle BE_{12}, BE_{2j}, \dots, BE_{i2}, \dots, BE_{n2} \rangle$ Total-states (figure 4).

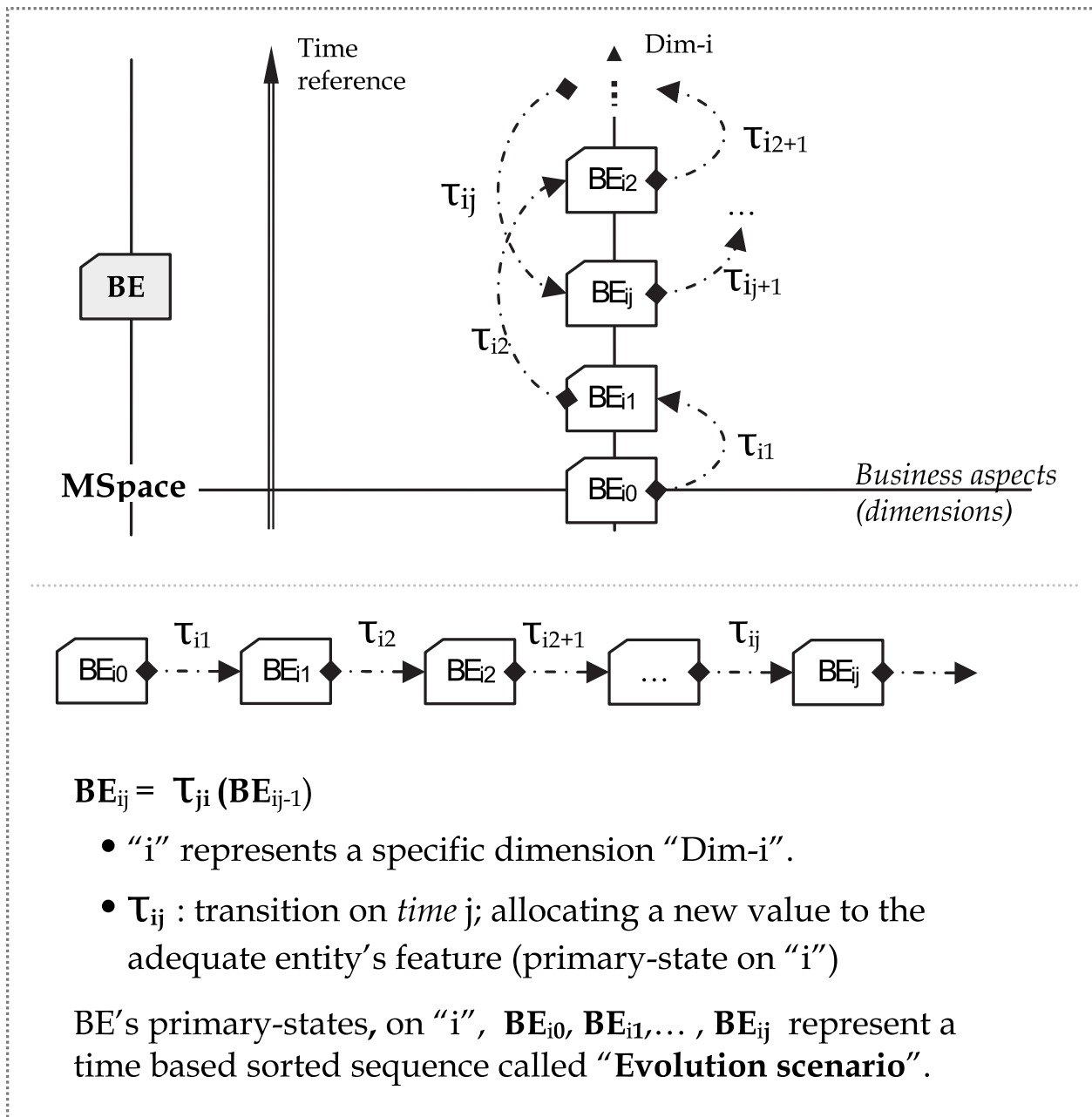

Fig. 3. Entity-States and Business-Profile basis and foundations

- **Global Transition and Business-Profiles;** named entities should have assigned at least one business-profile, e.g. “Mark get a new computer-science job position, **he is programmer**, and he *may became analyst* (predictable profile), etc.” Moving from one business-profile “programmer” to another profile “analyst” is qualified as Global-Transition; profile-based: “ $\tau_{profile,time}$ ”, figure 4.

e.g. *Mark’s new position; $\tau_{analyst, 20-07-2008}$ ($\tau_{programmer, 10-08-2006}$ (Mark)).*

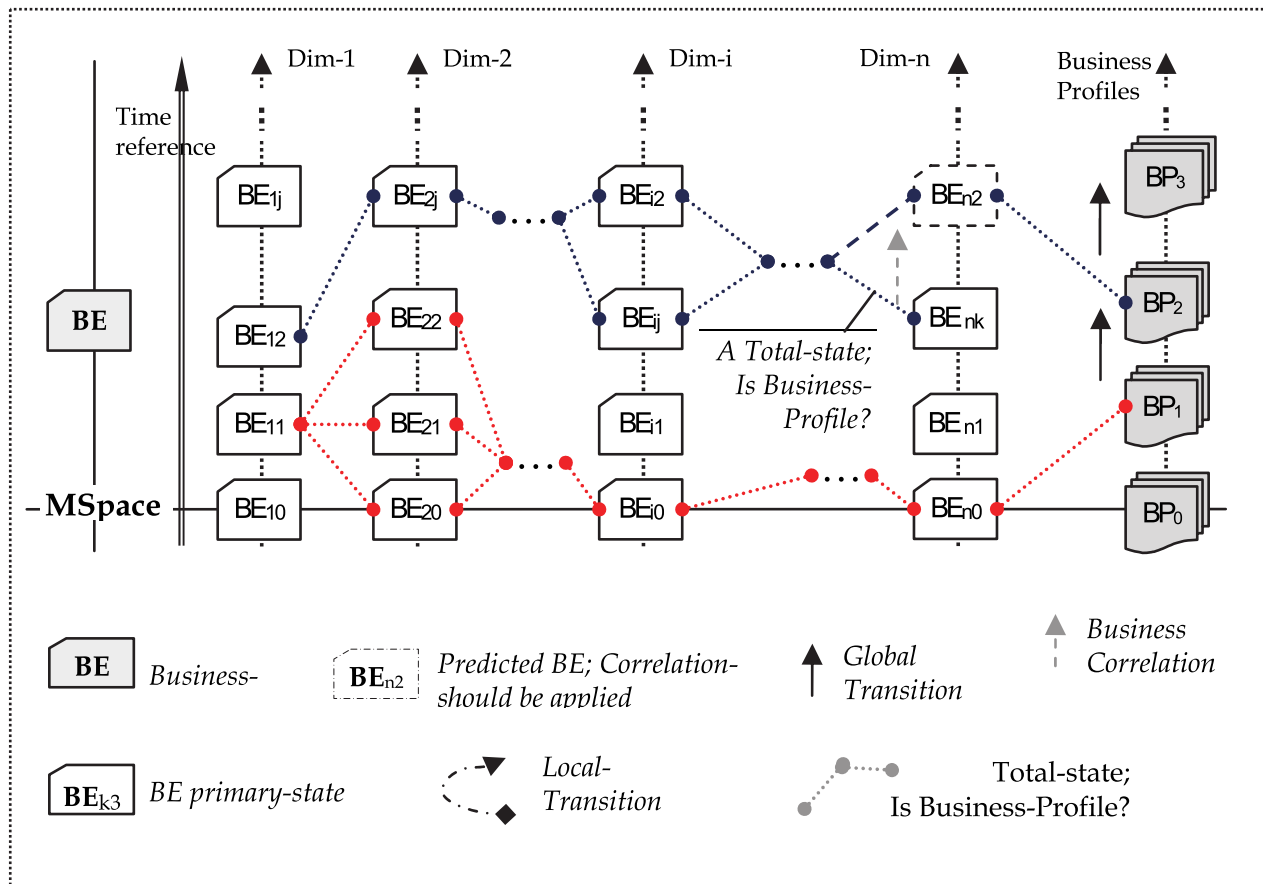

Fig. 4. Entity-States and Business-Profile basis and foundations

However, space designers are incited to identify, during the space modelling phase, at least one business-profile (default profile as well as default primary-states) that each business-entity starts from.

To conclude, The above theory and concepts may mainly be represented either using an algebraic formulation or conceptually by using and adopting the most popular computer-based data modelling techniques, i.e. UML-Like models (next sections).

4.2 BI-like capabilities

MSpace, which we work on, represents a long research project, the validation process refers to business intelligence (BI)-like techniques and practices; pattern-based analysis, business prediction. More capabilities are also integrated; business conduction and entity evolution correlation, etc.

However, the evolution capabilities, in MSpace, are mainly materialized by means of business transitions, especially Global-transitions that express entities progress and evolution. Business-transitions should agree, indeed, to some pre-elaborated management rules, they are directed, predicted and may be correlated and/or encouraged.

E.g. in figure 4 and 6, the current n-pstates $\langle BE_{12}, BE_{2j}, \dots, \{BE_{ij}, BE_{i2}\}, \dots, BE_{nk} \rangle$ couldn't be considered as significant Total-states, neither $\langle BE_{12}, BE_{2j}, \dots, BE_{ij}, \dots, BE_{nk} \rangle$ nor $\langle BE_{12}, BE_{2j}, \dots, BE_{i2}, \dots, BE_{nk} \rangle$. The insignificance is due to the last pstate "BE_{nk}".

Observation: In this case, the current business-profile “BP₁” for the considered entity remain applicable.

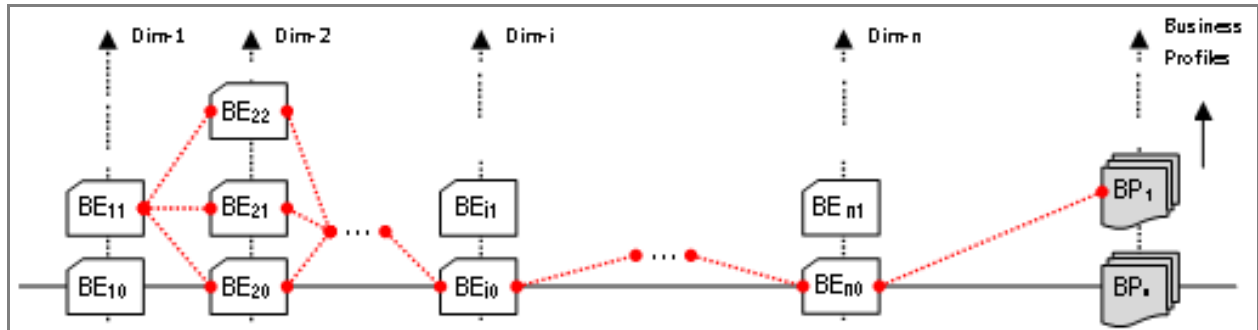

Fig. 5. Business-Profile basis; having multiple values on one aspect “Dim-2”

Direction - first attempt; estimate the distance (pstates one by one, e.g. “BE_{nk}” vs “BE_{n2}”) between the current Total-state and the nearest significant total-state (next profile). In case of an optimistic assess, the recommendation is to conduct the transition to the nominated profile “BP₂” by encouraging the local-transition from “BE_{nk}” to “BE_{n2}” (figure 4 and 6).

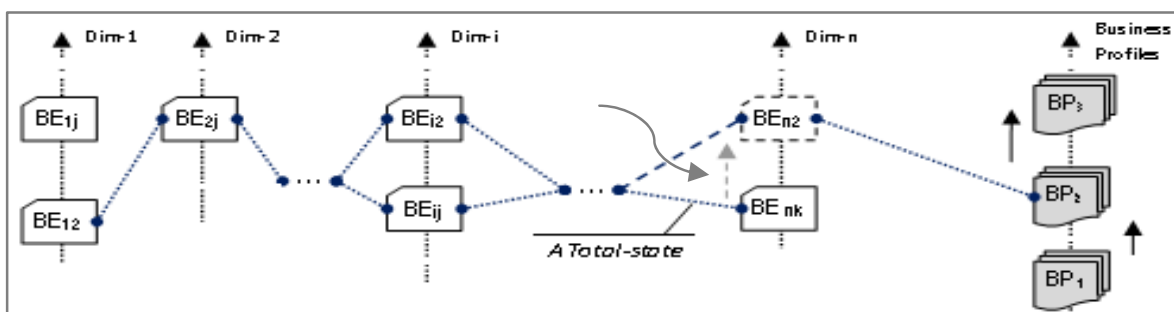

Fig. 6. Business-Profile basis; prediction issues

As shown before, there is a crucial need to introduce and elaborate some BI-like business rules such as “how could auto-conduct business-transitions”, etc. However, profile-based analysis, business conduction and correlation, etc. are just now initiated by an experimented operator; they should be enhanced and improved more and more.

4.3 Adaptive software solution

The software model that we adopt looks like a dedicated enterprise manager; transitions as well as pattern-based methodological analysis are Omni-incorporated.

Practically, we opted for component-based client/server software architecture (figure 7); it consists of:

- an Online-Repository-Manager (OMR) applying and emerging a dedicated data-model (next section),
- and two basic front-end modules:
 - an Online-Transition-Processing (OTP) module incorporating functionalities such as: setting-up space features (dimensions, etc.), building business entities, reworking entities, applying transitions, conducting and correlating entity’s transitions, etc.

- and an Online-Analytical-Monitoring (OAM) module; here we have two inter-related analytical components:
 - a business-entities' summarizer and explorer, this component leads to re-examine, review (play-back), etc., entity's states (scenarios) and all evolution related transitions. It, also, consists of regrouping, re-organising, re-connecting (semantic connectivity), etc., business entities.
 - and an open and dedicated Business-Intelligence (BI) component emerging and incorporating BI-like tools and functionalities. This component represents a curial analytical tool, it helps on conducting and directing entities' transitions, it also helps in correlating entities' evolution. Correlation is almost done according to applied business profiles. It, finally, helps in predicting and expecting entities' future states.

MSpace seems to be a framework intended to assume and emerge BI functionalities as well as analytical monitoring and exploration of the business-space.

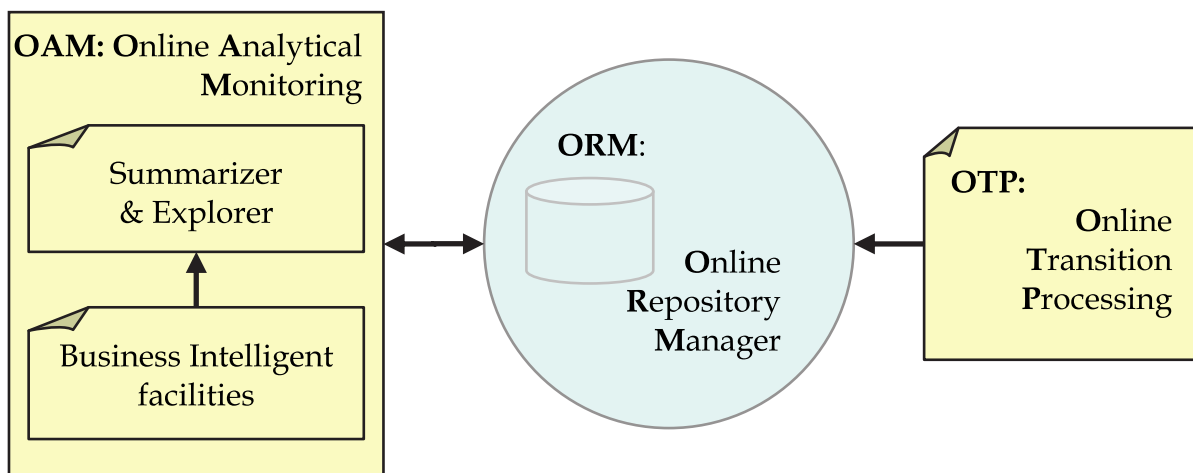

Fig. 7. Adaptive software Architecture

However, MSpace should undergo some building processes. The process aims to build the basic elements, for example, defining the space, building the dimensions and specify their types (discrete or continuous) and domains. Also build the business profiles and their domain intervals. Concerning the business-entities, each entity has its entity state, which describes the values taken at each dimension at a certain time. The business entity profile is the pattern that the entity could follow. Note that business entity could follow many business-profiles along its life cycle, but simultaneously only one is allowed.

4.3.1 The repository data model

The above theory and concepts may mainly be represented either using an algebraic formulation or conceptually by adopting the most popular computer-based data modelling techniques; UML-Like or ER models.

Practically, the proposed data-model incorporates and inherits concepts and theory from the so known multidimensional star schema (diagram in figure 8; BEntity, BEntityState). It also stimulates and materializes our two fundamental bases: (1) multi-sates business entities

shown as aggregation of *BEntityState*, (2) and pattern-based analysis referring to *BProfile* (Business Profiles) and *BEntityProfile* conceptual elements that should conduct business-entities evolution.

Finally, setting-up a space, it leads to:

- Generic solution - that instantiates as needed the MSpace and all related features; BProfile, BDim, etc. and the BEntity, BEntityProfile, etc.
- e.g. Employees(named collection) is a set of BEntity.
- or Extendible and case related solution (framework oriented) - allow an engineering procedure leading to initiate (hard coding) and name new domain-related conceptual elements;;
- e.g. Employee ISA BEntity..., Employees (named collection) is a set of Employee.

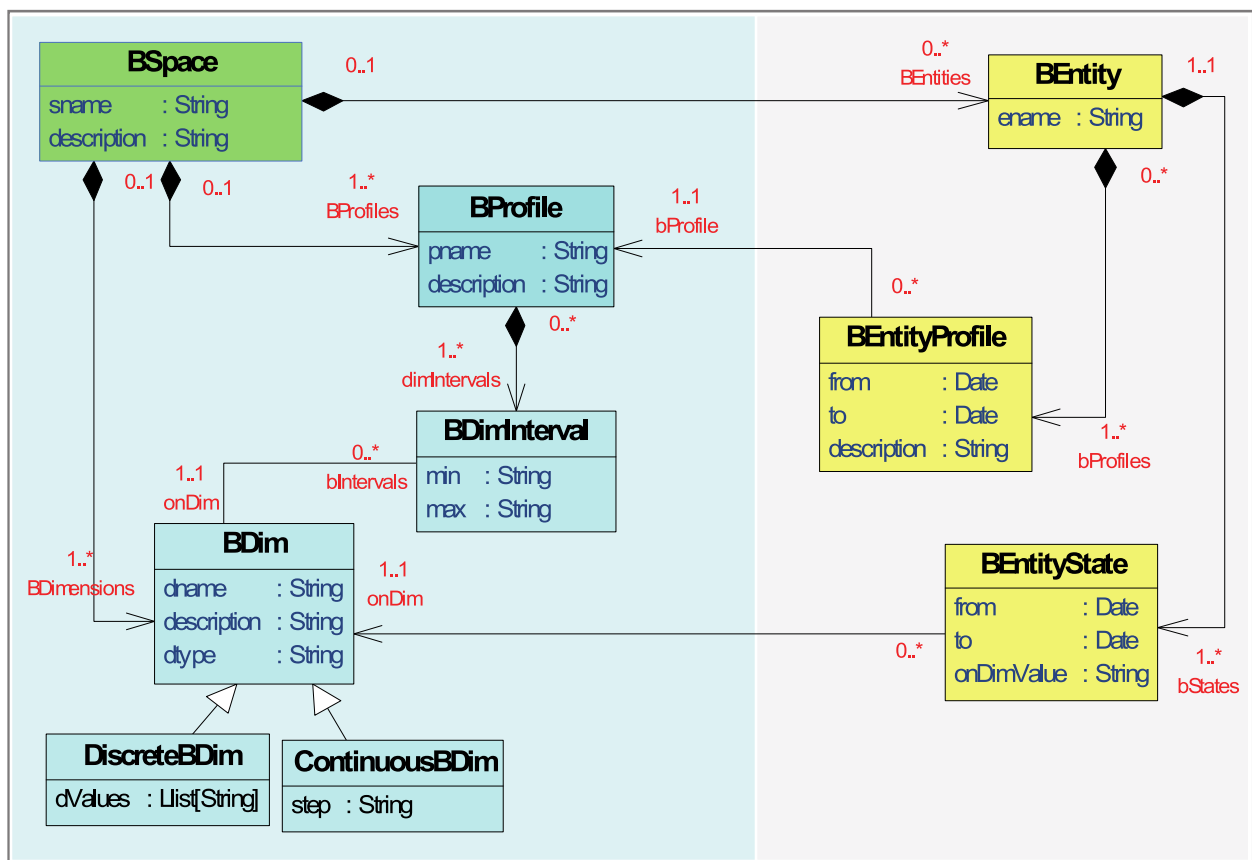

Fig. 8. UML-like multidimensional/state conceptual data model

The above solutions both are valid and applicable. Consequently, the adopted software model allowed an easy setting up and validation of the above data model.

4.3.2 BL Like End-User interface

The end-user interface model supports navigational as well as analytical functionalities; it consists of two main software components (figure 9):

- *Tree-like area* (left side) - it consists of an expandable/collapsible tree that emerges space instances, space aspects/dimensions, business entities, entity states, named business profiles, etc. End users should be able to setup spaces and navigate and explore business features.
- and a *Workspace home area* (right side) - it consists of a large run-time area emerging business-analysis, monitoring, etc. This component plays a crucial role; it should constantly support the analytical approach.

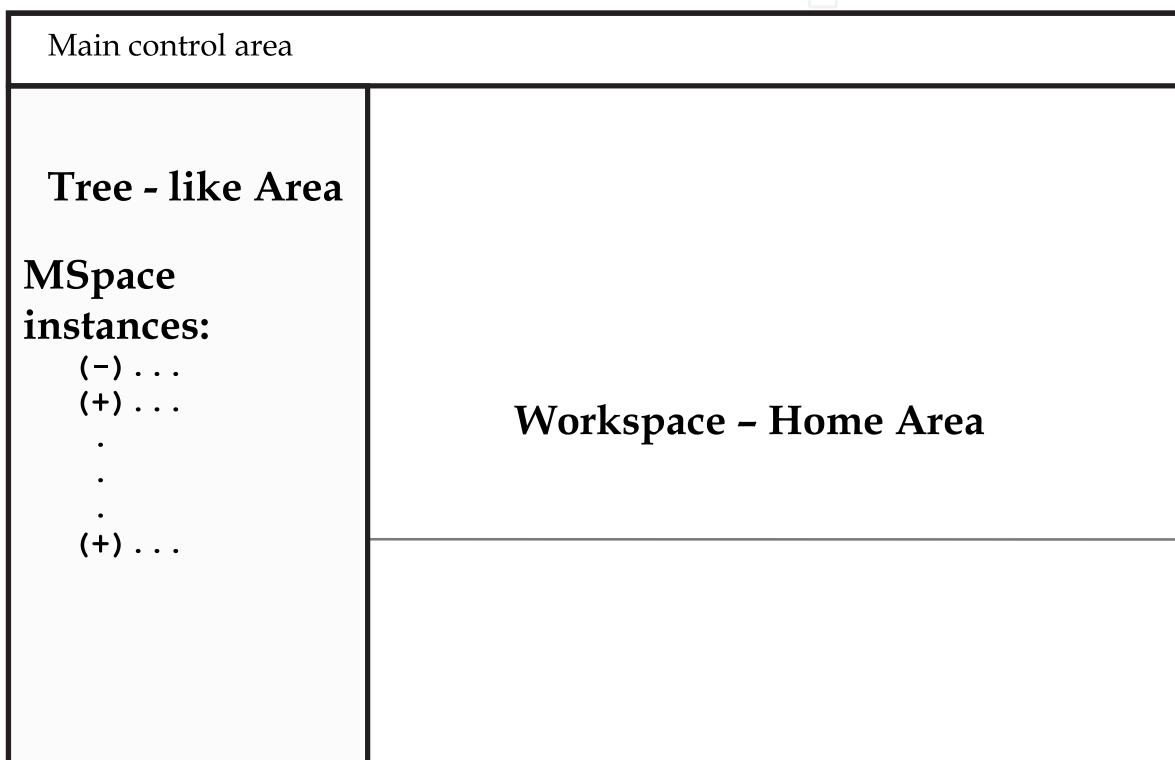

Fig. 9. End user interface

The interface model is intended to be simple, interactive and easy to use; our main goal is to express and demonstrate the above approach and theory. Java APIs (JPA, JPQL, etc.) and facilities provided by Microsoft platform are/have-been used in the validation and prototyping phase.

4.4 Validation and criticism

We are going, in the next section, to deeply consider one typical case study. The study is about employee life cycle analysis “Human Resource Management (HRM)” in the “Lebanese University”, the space that we consider is simple and contains single business-entities type. The second case is about city evolution analysis, here the space is complex and partitioned into subspaces, and each subspace could have different type of business-entities.

4.4.1 Case study – Human resource tracking

Human resource (HR) in public sector or in private companies faces enormous challenges in dealing with the growing complexity of managing vast amounts of employee information. Large amounts of employee's historical data and other processes, such as: adding new employees, change the employee state, and even prediction of new employee's state or position, can be managed in business intelligent (BI) system that collect active (on-line) data to make pattern-based-analysis to monitor the employee's life cycle. Improving HR process management can result in significant advantages, especially lower costs, reduced risk, enhanced productivity, and a more comprehensive, reliable and efficient means of managing employee information.

By applying MSpace approach that provides Business Process Management capabilities to HR operations, companies can rise in a progressive strategy for employee lifecycle management, whereby the HR department can effectively manage all relevant employee documents and transactions from "hire to retire". MSpace can enable an organization to eliminate inefficient manual processes that waste valuable employee time. Also, it can provide consistency in executing business processes, and ensure that processes are executed according to industry or governmental requirements.

Mapping case study about the employees' life cycle in the Lebanese University, it is hard to establish analysis about each employee by HR and make analysis about his state, and prediction about his future state, especially when we have a large amount of employee, it takes a lot of effort and time, and it may cost too much, also it may not be accurate. So it is more efficient if we build a BI system with pattern-based-analysis to manage the employee life cycle

Building process: In this case study, we consider that each employee has certain dimensions, such as *gender, age, years of duty, education degree, marital status, job specification*. For each of these dimensions, employees can take values from a predefined set of domain indicators that restrict the values at each dimension. Evolution of employee's state at a certain dimension can have an impact on his values of at other dimensions.

Dimensions:

Age: *The length of time that one has existed. Values: positive integer ϵ [18, 64].*

Marital status: *the condition of being married or unmarried. Values {single, married, divorced}.*

Education level: *the certificates that a person must have in order to apply for a certain job. Values {baccalaureate, BS, BA, MA, MBA, PHD}.*

Years of duty: *the experience that a person had in a certain job. Domain: positive integer ϵ [18, 46].*

Job specification: *a statement of employee characteristics and qualifications required for satisfactory performance of defined duties and tasks comprising a specific job or function. Job specification is derived from job analysis. Values: {manager, professor, accouter, data entry, supervisor, assistant, secretary}.*

Personnel behaviour: *The actions or reactions of a person in response to external or internal stimuli. Values {Bad, Fair, Good, Very good}.*

As shown in the figure 10, there is a set of dimensions that specify the employee life cycle, here the employee known as business entity (BE), these BEs navigate in this multi-dimensional space taking a range of allowed values along dimensions. BEs can follow certain patterns based in order to reach a goal; these patterns offer a range of values at each dimension for those BE, later we will see a set of patterns in the multi-dimension diagram, that draw a road map for BEs to navigate along it.

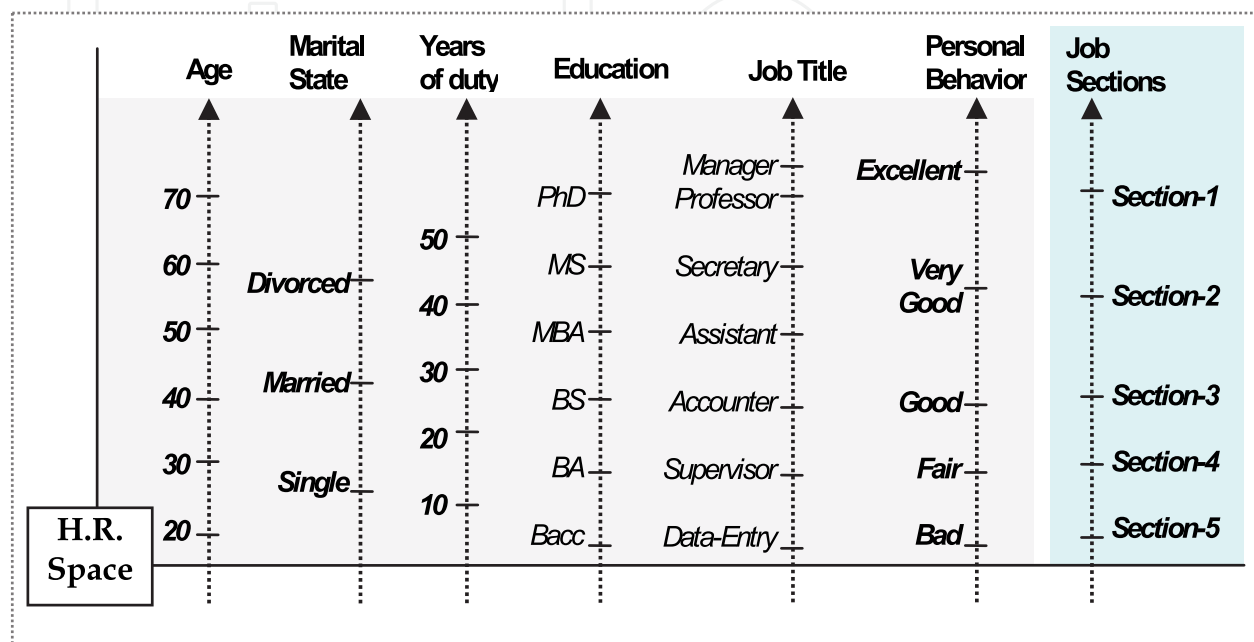

Fig. 10. HR space; business features - dimensions and profiles

Employee Profiles (Named patterns) - As follows, all the business patterns will be mentioned in order to have a clear idea about the allowed employee state transitions:

Job section (salary dependent): each employee has a degree that merges his/her education level and job specification, this degree has an effect in salary, social security level, and employee's state evolution. Values {Section 1, Section 2, Section 3, Section 4, Section 5}.

Employee Profiles and evolutive rules:

Transition to job section 3: if an employee held baccalaureate certificate and he/she is in job section 4 could not be able to transit to job in section 3, unless he/she has at least BA/BS certificate nor has more than 10 years of duty. In both cases, the employee must have good/very good personal behaviour. Note that, changes along all other dimensions will not affect the employee state.

Manager position : if an employee is in section 3 and held MBA/MS certificate or a professor can transit into manager position, in both cases, employee/professor should have more than 5 years in duty and good/very good personal behaviour. Transition occurs only when the position at a certain job section is available.

Transition to section 4: if an employee is in section 5 and wants to become in section 4, he/she wants to hold the baccalaureate certificate and has more than 5 years in duty and considered as fair personal behaviour or above.

Employee Database (instances are compacted):

In the following table, there are some data collected from online database of the Lebanese university faculty of science. Note that each distinct record considered as a single Business Entity (BE), has its set of values along each dimension that combine to formulate business entity state.

Name	Age	Marital status	Educ-ation	Years of duty	Job specification	Job Section	Personal behavior
S. Harb	35	Married	BA	6	Accounting	Section 3	Good
F. Soloh	40	Married	BS	11	Supervisor	Section 3	V.Good
S. Hamoud	45	Single	Bacc	22	Data entry	Section 4	Good
A. Kanj	55	Married	PHD	18	Manager	Section 2	V.Good
R. Bitar	58	Married	PHD	15	Professor	Section 2	V.Good
H. Aloush	40	Married	BS	12	Accouter	Section 3	V.Good
H. Badra	40	Married	BA	15	Secretary	Section 4	Good
S. Sibaia	36	Single	Bacc	6	Data entry	Section 4	Fair

Table 1. HR space; an empirical database for Employees

Employee Evolution Issues - There are a set of business pattern (BP) that constraint the transition of BEs from a state to state, BE cannot transits unless it satisfies the constraints for a certain BP. In our case study (human resource department in the Lebanese university), there are many BPs that constraint the employee evolution along the job specification dimension.

Consider the following case that illustrates the proposed patterns, here there is an employee called "S.Hamoud" <45, Single, **Bacc**, 22, Data entry, Good, **Section 4**>, she is in job section 4 and she held the baccalaureate certificate and she behave well, but later she obtained a BS in science which results to a state transition in job section form 4 to 3.

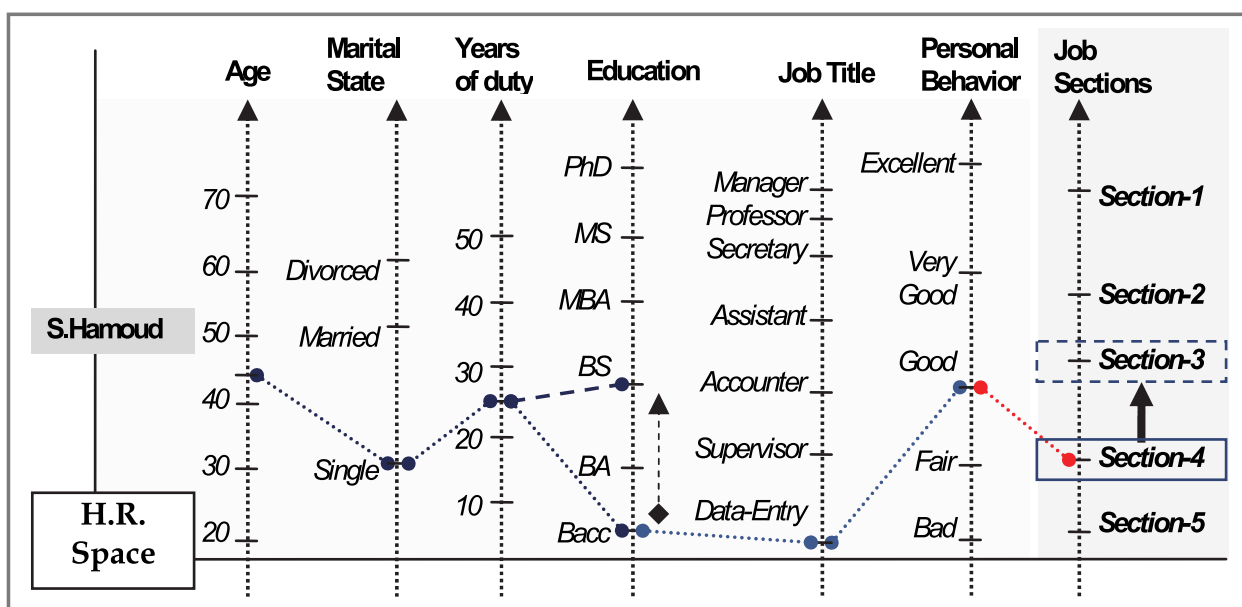

Fig. 11. Employee life cycle evolution; the employee got a new degree!

In the figure 11, we see the dash line that describe the current state of "S.Hamoud", but later on she obtained BS certificate (dashed line), this change leads to evolution at the section level dimension and become at value 3.

Entity values may evolve at any dimension and this evolution may leads to transition to new state based on predefined pattern analysis. Furthermore, certain state transitions need an evolution at more than one dimension to be omitted, for example, if an employee at accounting position held BA in business management and he is 30 years old may not be a manager, unless he complete his master degree and he is above 35.

In this case we have the employee "H.Aloush" <40, Married, BS, 12, Accouter, V.Good, Section 3> in job section 3, an evolution occurred at the education level from BS into MBA, this evolution in addition to the overall state of Ms. Aloush lead to two transitions in the job specification and job section dimensions. By this transition Ms. Aloush may become a manager and in section 3, as shown in figure 12.

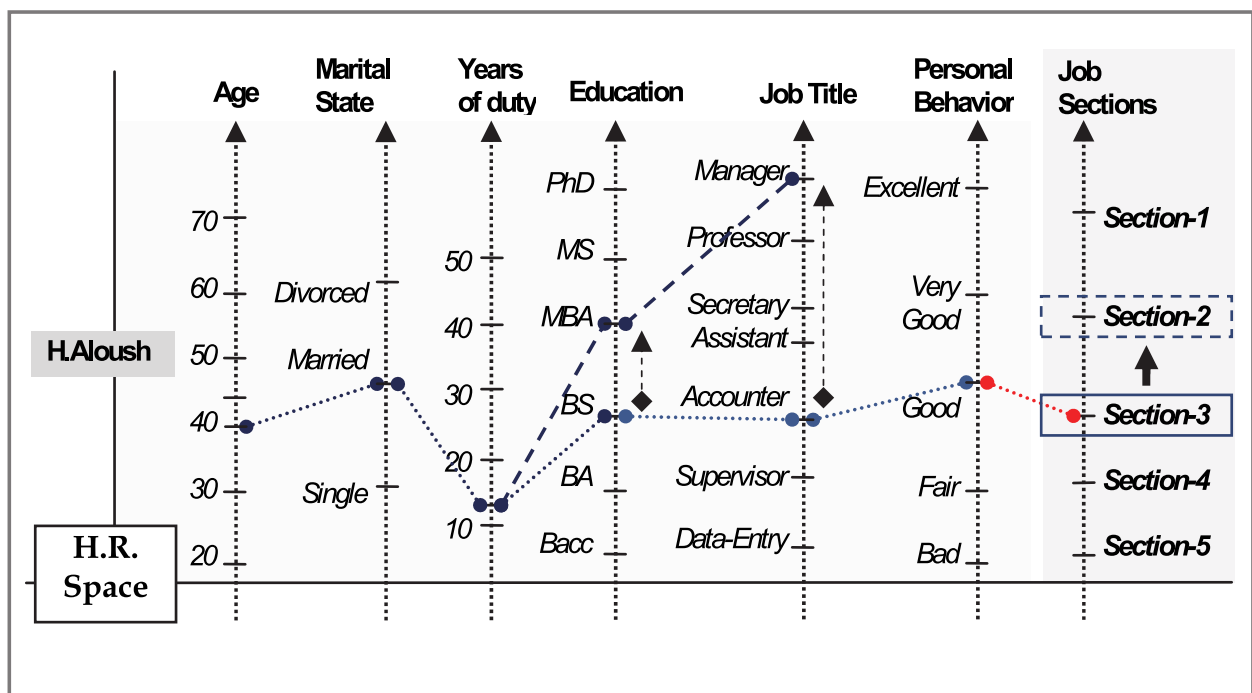

Fig. 12. The employee (H. Aloush) became Manager; H. Aloush should be repositioned in his job sections!

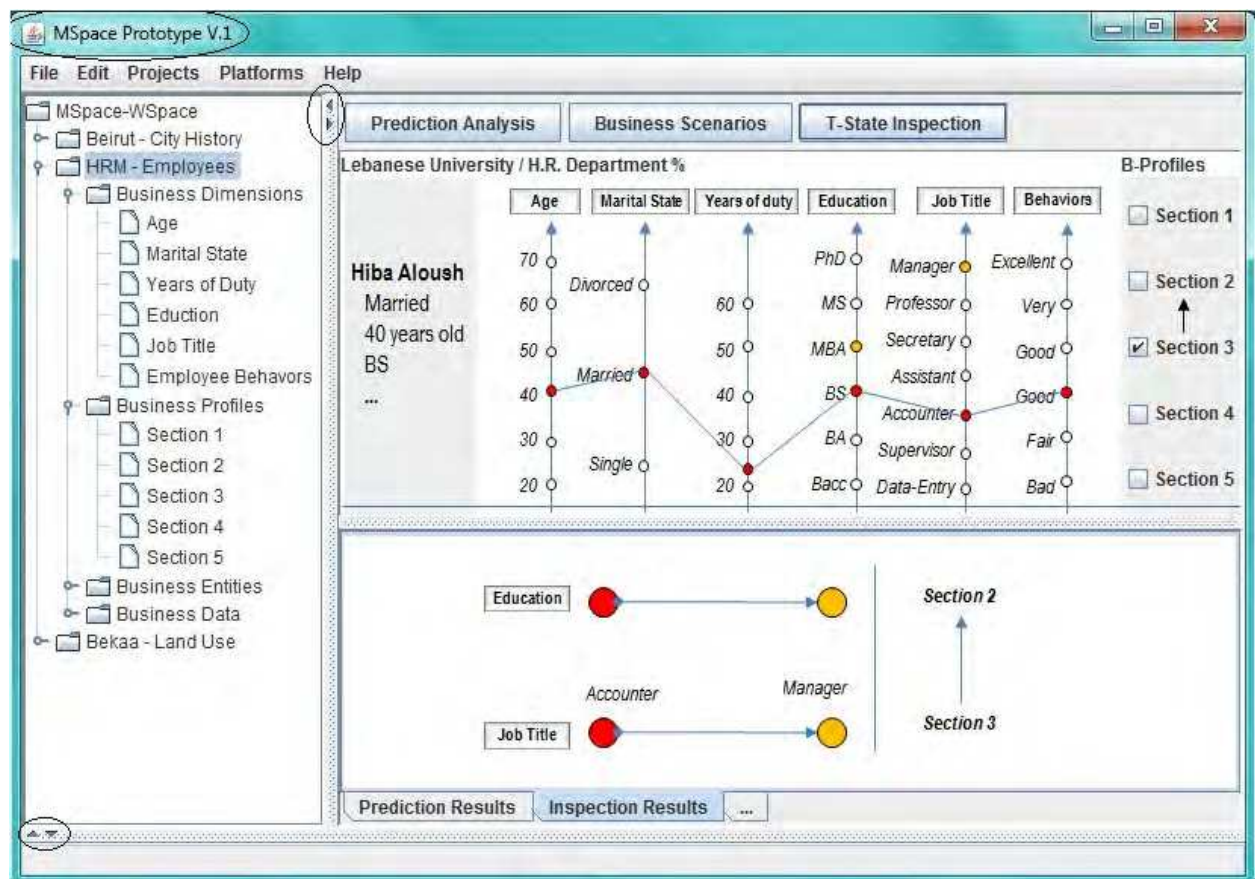

Fig. 13. MSspace software prototype

Otherwise, our business-analysis theory is about to be integrated in the MSspace software prototype (figure 13). The experiments show that the restrictions made on the space (building process; dealing with only one entities type) are so useful and give very good results.

4.4.2 Complex case study and criticism

The idea behind this section is to express the big challenges that we are faced where the space is qualified as complex. Given materials are hypothetical, devised theory is still under validation!

However, we trying, in this section, to analyze and track the evolution in a city, we record and analyze futures, and urbanization from multiple perspectives. We partition the city into a set of adjacent areas (figure 14), these areas are seen as business entities. Those entities take values along a set of dimensions such as: Building, Street, Garden, etc. Here business entities are subspaces that are each one is considered as independent space that has its entities, dimensions and patterns; towards hyper-mspace.

Dimensions - At the first level the space contains set of areas and three dimensions:

Building: Permanent or temporary structure enclosed within exterior walls and a roof, etc. Values {civil building, hospital, school, university}.

Street: a public thoroughfare, usually paved, in a village, town, or city, including the sidewalk or sidewalks. Values {public, private}.

Garden: a plot of ground, usually near a house, where flowers, shrubs, vegetables, fruits, or herbs are cultivated. Values {area, capacity, location}.

etc.

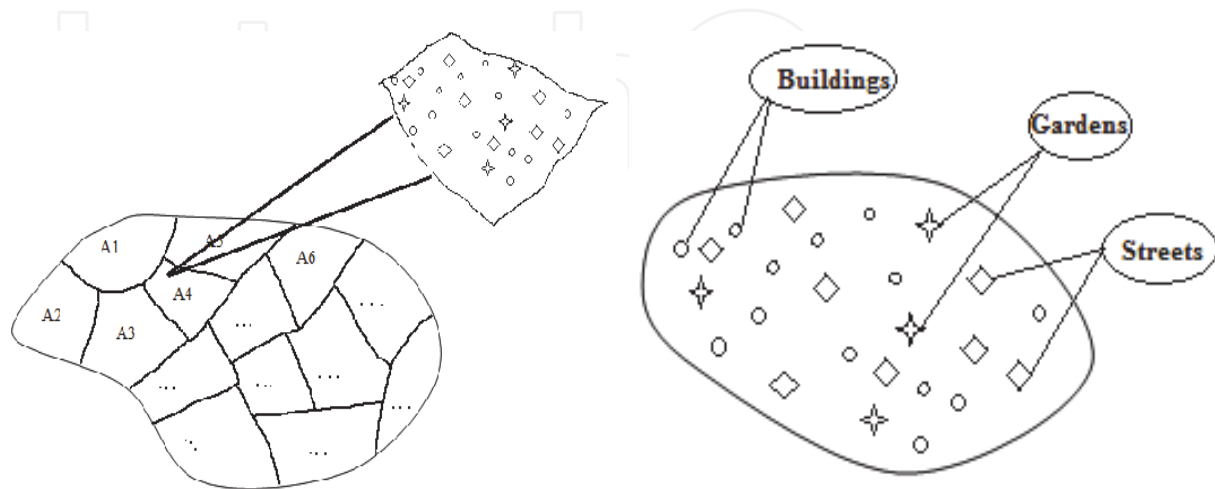

Fig. 14. Space decomposition

Business Patterns/Profiles -

Area is fully constructed: where no other building, street or garden could be added, the ratio of civilians to the number of buildings, streets and gardens used to make decision about the capacity of the area.

Area is not fully constructed: where some building, street or garden could be added.

Only gardens could be added: since the ratio of total area to the number of buildings and streets is fair in order not to have overpopulation.

etc.

As we mentioned the space (city) is partitioned into set of subspaces (areas), each one has its business-entities and patterns. Subspaces have common dimensions and may contain different types of independent BEs, where in some cases evolution in BE's state may influence other BEs. By projection along areas we introduced into subspaces with more dimensions, these subspaces contain BEs with different categories such as building, street, and garden.

Relating to the inner spaces, there are a set of dimensions that describe them and the specification of each categories and their dimension is defined as follows:

Dimensions of Buildings category: Height; Values {real positive number}, Area of the building; Values {real positive number}, Distance from street; Values {real positive number}, Capacity of the building; Values {positive integer}, etc.

Consider, for example, the subspace (area A4 in figure 14) called "Down Town", it contains a set of business entities from different categories: Buildings, Streets, etc. So the

transformation of one entity may influence other entities, note that we can trace the state of BE into a diagram and make comparison and analysis with other BE. For example, the presence of building in such place requires the presence of street, and the presence of 20 buildings or more requires the presence of a garden.

As a result, the partition of city into sub-areas facilitates analysis, support decision making and prediction of BEs' states and transitions along dimensions.

4.4.3 Observation and criticism

As we seen in the previous case studies, space may be simple where only one type of business entity could be founded, or complex and composite with different types of business entities.

The experiments show that we are pressed, during the validation process, to decide with what category we are going to deal with; simple and/or complex spaces. Theoretically, the most typical spaces are simple or should be simplified / restricted. Restrictions are indeed about the space constitution itself; they regard the space building process.

Practically, spaces are usually complex, and business-entities could be referred to many different categories, they could interact and influence each other, etc.

To conclude, the model should be applied to all cases; simple or complex, e.g. Marine navigation tracking, Soldiers and lifesaving in risked areas, Biomedical treatments and experiments, etc. As a result, the above approach is still under elaboration, complex cases aren't yet solved. In the next phase, we plan to elaborate a deep theory that deals with such cases; interaction rules, space subdivision rules, hierarchical space constitution (multi-levelling space), vertical navigational rules (summarising, zooming, etc.), etc.

5. Conclusion

Data growth consistently, and day by day, emergent technologies are solicited more and more. Business applications became more intelligent, due to the advance in data computation and integration technologies.

The approach "MSpace" that we proposed represents an initiative leading to provide a flexible modelling framework. We started by elaborating features and foundations that introduce and characterize concepts of evolutive/mutable space and business entities. We stated that business entities are reactive, multidimensional and multi-states. Business entities transit, continually, from one state to another state; entity-states (primary or total) characterize entity-transitions. In MSpace business-entities' transitions are predicted and, usually, conducted, they could be correlated with respect to pre-elaborated patterns (Business Profiles).

Practically, MSpace is end-user oriented tool intended to stimulate business intelligence facilities such as pattern-based analysis and an analytical navigation through space components; it inherits both OLTP and OLAP characteristics. The tool consists mainly of one emergent data model (ORM: Online Repository Manager) and a BI-like Examiner and explorer (OAM: Online Analytical Monitor).

After specifying the software architecture, we opted during the validation process for Java platform; the devised prototype is attractive and hopeful. We started validating the tool through two different and distinguishable space categories; *simple* mono entities type (case study: employee life cycle analysis in the Human Resource department in the Lebanese University) and *complex* without restrictions on the entity types (case study: city evolution analysis).

Rather than the elegant and hopeful outcomes, the experiments show that we need to deploy more efforts regarding especially the second category of MSpace's instances. As a result, we need indeed to state for a complete complex-space building and exploring theory; we need to answer questions like "how the space could be partitioned", "how entities could interact and influence each other", "how could navigate through different levels", etc., such questions outline, finally, our future research.

6. References

- Dbouk & Sbeity 2009, Dbouk, M. & Sbeity, I. (2009). *GeoSEMA: A Modelling Platform, Emerging GeoSpatial-based Evolutionary and Mobile Agents*. World Congress on Science, Engineering and Technology (WCSET 2009); Conf. Proceedings ISSN: 2070-3740, March 23-25, 2009, Hong Kong, China.
- Erwig et al., 1999, Erwig, M.; Güting, R. H., Schneider, M. & Vazirgiannis, M. (1999). *Spatio-Temporal Data Types: An Approach to Modeling and Querying Moving Objects in Databases*. In *Geoinformatica*, vol.3 n.3, p.269-296, September 1999.
- Pestana & da Silva, 2005, Pestana, G. & da Silva, M. M. (2005). *Multidimensional Modeling Based on Spatial, Temporal and Spatio-Temporal Stereotypes*. ESRI Inter. User Conference July-25-29 (2005), San Diego Convention Centre, California.
- Pelekis et al. 2006, Pelekis, N.; Theodoridis, Y., Vosinakis, S. & Panayiotopoulos T. (2006). *Hermes - A Framework for Location-Based Data Management*. In EDBT 2006, Springer Lecture Notes in Computer Science, Vol. 3896, pp.1130-1134.
- Praing & Schneider, 2007a, Praing, R. & Schneider M. (2007). *A Universal Abstract Model for Future Movements of Moving Objects*. In AGILE International Conference on Geographical Information Systems, 2007.
- Praing & Schneider, 2007b, Praing, R. & Schneider M. (2007). *Modeling historical and future movements of Spatio-temporal objects in moving objects databases*. In proceedings of the 16th ACM Conf. on Information and Knowledge Management (CIKM), p183-192, Lisbon- Portugal, Nov. 6-10, 2007.
- Hammam et al., 2004, Hammam, Y.; Moore A., Whigham P. & Freeman C. (2004). *Irregular vector-agent based simulation for land-use modelling*. In 16th Annual Colloquium of the Spatial Information Research Centre (SIRC 2004: A Spatio-temporal Workshop), 29-30 November 2004, Dunedin, New Zealand, pp. 103-116.
- Zhang et al., 2007, Zhang, L.; Yin, X. & Liu, Y. (2007). *Multidimensional modelling of marine water body based on time series multi-surfaces*. Society of Photo-Optical Instrumentation Engineers, Bellingham, 2007 SPIE, Bellingham, Wash., ETATS-UNIS (2007)

Trujillo et al., 1999, Trujillo, J.; Polamar, M. & Gomez, J. (1999). *Detecting patterns and OLAP operations in the GOLD model*. ACM New York, NY, USA 1999.

IntechOpen

IntechOpen

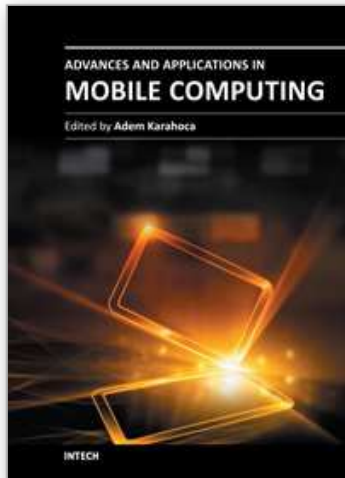

Advances and Applications in Mobile Computing

Edited by Associate Prof. Adem Karahoca

ISBN 978-953-51-0432-2

Hard cover, 224 pages

Publisher InTech

Published online 30, March, 2012

Published in print edition March, 2012

Advances and Applications in Mobile Computing offers guidelines on how mobile software services can be used in order to simplify the mobile users' life. The main contribution of this book is enhancing mobile software application development stages as analysis, design, development and test. Also, recent mobile network technologies such as algorithms, decreasing energy consumption in mobile network, and fault tolerance in distributed mobile computing are the main concern of the first section. In the mobile software life cycle section, the chapter on human computer interaction discusses mobile device handset design strategies, following the chapters on mobile application testing strategies. The last section, mobile applications as service, covers different mobile solutions and different application sectors.

How to reference

In order to correctly reference this scholarly work, feel free to copy and paste the following:

Mohamed Dbouk, Hamid Mcheick and Ihab Sbeity (2012). MSpace: An Emergent Approach, Modelling and Exploring Mutable Business-Entities, Advances and Applications in Mobile Computing, Associate Prof. Adem Karahoca (Ed.), ISBN: 978-953-51-0432-2, InTech, Available from:

<http://www.intechopen.com/books/advances-and-applications-in-mobile-computing/mspace-an-emergent-approach-modelling-and-exploring-mutable-business-entities>

INTECH
open science | open minds

InTech Europe

University Campus STeP Ri
Slavka Krautzeka 83/A
51000 Rijeka, Croatia
Phone: +385 (51) 770 447
Fax: +385 (51) 686 166
www.intechopen.com

InTech China

Unit 405, Office Block, Hotel Equatorial Shanghai
No.65, Yan An Road (West), Shanghai, 200040, China
中国上海市延安西路65号上海国际贵都大饭店办公楼405单元
Phone: +86-21-62489820
Fax: +86-21-62489821

© 2012 The Author(s). Licensee IntechOpen. This is an open access article distributed under the terms of the [Creative Commons Attribution 3.0 License](#), which permits unrestricted use, distribution, and reproduction in any medium, provided the original work is properly cited.

IntechOpen

IntechOpen