

We are IntechOpen, the world's leading publisher of Open Access books Built by scientists, for scientists

4,800

Open access books available

122,000

International authors and editors

135M

Downloads

Our authors are among the

154

Countries delivered to

TOP 1%

most cited scientists

12.2%

Contributors from top 500 universities



WEB OF SCIENCE™

Selection of our books indexed in the Book Citation Index
in Web of Science™ Core Collection (BKCI)

Interested in publishing with us?
Contact book.department@intechopen.com

Numbers displayed above are based on latest data collected.

For more information visit www.intechopen.com



Fuzzy Control: An Adaptive Approach Using Fuzzy Estimators and Feedback Linearization

Luiz H. S. Torres and Leizer Schnitman

*Centro de Capacitação Tecnológica em Automação Industrial (CTAI),
Universidade Federal da Bahia, Rua Aristides Novis, nº 02, Escola Politécnica, 2º andar,
Salvador, Bahia
Brazil*

1. Introduction

In recent years the area of control for nonlinear systems has been the subject of many studies (Ghaebi et al., 2011; Toha & Tokhi, 2009; Yang & M., 2001). Computational advances have enabled more complex applications to provide solutions to nonlinear problems (Islam & Liu, 2011; Kaloust et al., 2004). This chapter will present an application of fuzzy estimators in the context of adaptive control theory using computational intelligence (Pan et al., 2009). The method is applicable to a class of nonlinear system governed by state equations of the form $\dot{x} = f(x) + g(x)u$, where $f(x)$ and $g(x)$ represent the nonlinearities of the states. Some classic control applications can be described by this specific class of nonlinear systems, for example, inverted pendulum, conic vessel, Continuously Stirred Tank Reactor (CSTR), and magnetic levitation system. The direct application of linear control techniques (e.g.: PID) may not be efficient for this class of systems. On the other hand, classical linearization methods may lead an adequate performance when the model is accurate, even though normally limited around the point in which the linearization took place (Nauck et al., 2009). However, when model uncertainties are considerable the implementation of the control law becomes difficult or unpractical. In order to deal with model uncertainties an adaptive controller is used (Han, 2005; Tong et al., 2011; 2000; Wang, 1994). The controller implements two basic ideas. First, the technique of exact feedback linearization is used to handle the nonlinearities of the system (Torres et al., 2010). Second, the control law formulation in presence of model uncertainties is made with the estimates of the nonlinear functions $f(x)$ and $g(x)$ (Cavalcante et al., 2008; Ying, 1998). The adaptation mechanism is used to adjust the vector of parameters θ_f and θ_g in a singleton fuzzyfier zero-order Takagi-Sugeno-Kang (TSK) structure that provides estimates in the form $f(x|\hat{\theta}_f)$ and $g(x|\hat{\theta}_g)$. The fuzzy logic system is built with a product-inference rule, center average defuzzyfier, and Gaussian membership functions. One of the most important contributions of the adaptive scheme used here is the real convergence of the estimates $f(x|\hat{\theta}_f)$ and $g(x|\hat{\theta}_g)$ to their optimal values $f(x|\theta_f^*)$ and $g(x|\theta_g^*)$ while keeping the tracking error with respect to a reference signal within a compact set (Schnitman, 2001). Convergence properties are investigated using Lyapunov candidate functions. In order to illustrate the methodology, a nonlinear and open-loop unstable magnetic levitation system is used as an example. Experimental tests in a real plant were conducted to check the reliability and robustness of the proposed algorithm.

2. A specific structure

The proposed method is applicable to a specific class of nonlinear system that can be described by state equations of form:

$$\begin{cases} \dot{x} = Ax + B[f(x) + g(x)u] \\ y = Cx \end{cases} \quad (1)$$

where,

$$\begin{aligned} A &= \begin{bmatrix} 0 & 1 & 0 & \cdots & 0 \\ 0 & 0 & 1 & \cdots & 0 \\ \vdots & \vdots & \vdots & \ddots & \vdots \\ 0 & 0 & 0 & 0 & 1 \\ 0 & 0 & 0 & 0 & 0 \end{bmatrix}_{n \times n} \\ B &= [0 \ \cdots \ 0 \ 1]^T_{1 \times n} \\ C &= [1 \ 0 \ \cdots \ 0]_{1 \times n} \end{aligned} \quad (2)$$

n is the dimension of the system

$x \in X \subset \mathbb{R}^n$, are the states of the system

$f(x) : \mathbb{R}^n \rightarrow \mathbb{R}$ s.t. $f(x)$ is continuous and $f(x) \in U_f \subset \mathbb{R}, \forall x \in X$

$|f(x)| \leq f^U, \forall x \in X$

$g(x) : \mathbb{R}^n \rightarrow \mathbb{R}$ s.t. $g(x)$ is continuous and $g(x) \in U_g \subset \mathbb{R}, \forall x \in X$

$0 < \zeta < |g^L| \leq |g(x)| \leq |g^U|, \forall x \in X$, for a constant $\zeta > 0$

u is the control signal

y is the output signal

or, in an equivalent form:

$$\begin{cases} \dot{x}_1 = x_2 \\ \dot{x}_2 = x_3 \\ \vdots \\ \dot{x}_n = f(x) + g(x)u \\ y = Cx = x_1 \end{cases} \quad (3)$$

where X, U_f and U_g are compact sets, $sign(g(x)) = sign(g^L) = sign(g^U)$ and $x = 0$ is an interior point of X .

2.1 Examples of nonlinear systems

Once the class of nonlinear systems is defined, it is important to select a plant to highlight the controller properties. As this structure is very common in control applications, some classic systems can be written using Equation (1) format (see below Figure (1)):

3. Control law

Consider a nonlinear system described by state equations in the form of Equation (1). Let the control objective be to track a reference signal $r(t) \in S \subset \mathbb{R}$, where S is a compact set of possible references which can be supplied to the nonlinear plant.

Exact feedback linearization technique can be used here for exacting cancellation of the nonlinear functions $f(x)$ and $g(x)$ (Isidori, 1995; Slotine & Li, 1991; Sontag, 1998). If one

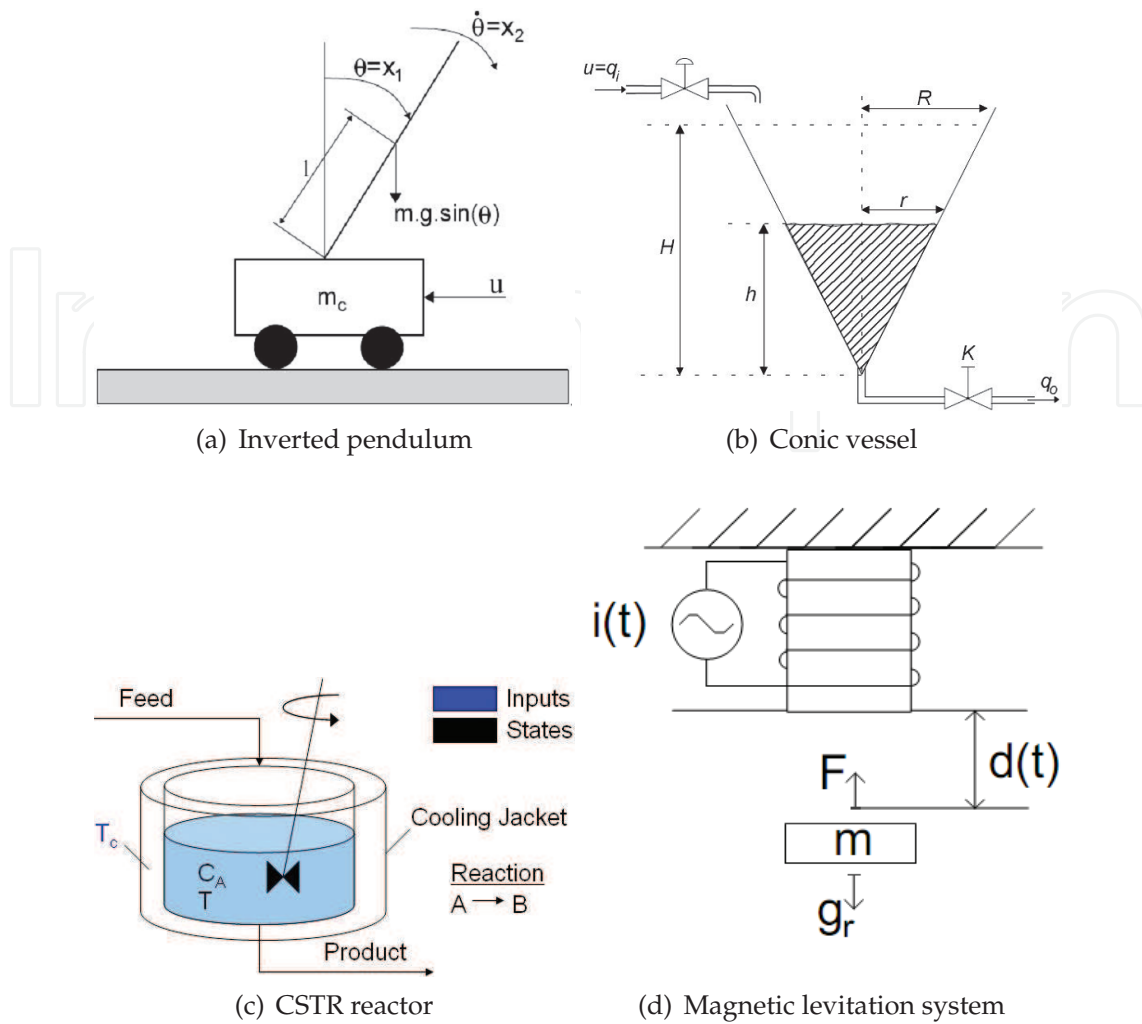

Fig. 1. Examples of nonlinear systems

assumes that the functions $f(x)$ and $g(x)$ are known, then an interesting structure for the control law would be

$$u = \frac{1}{g(x)} [-f(x) + D(x)] \tag{4}$$

where D is to be selected in the design phase.

By substituting Equation (4) in the nonlinear system Equation(1) one gets

$$\dot{x} = Ax + BD(x) \tag{5}$$

so that $\dot{x}_n = D(x)$, which can be chosen as the desired dynamics for the controlled system.

3.1 Example

Let a gain vector K be

$$K = [K_1, \dots, K_n] \in R^n \tag{6}$$

and consider $D(x) = r - Kx$. The proposed control law becomes

$$u = \frac{1}{g(x)} [-f(x) + r - Kx] \quad (7)$$

By substituting Equation (7) in the nonlinear system in Equation (1), one gets

$$\dot{x} = (A - BK)x + Br \quad (8)$$

which yields a linear dynamic. In this case, the stability can be verified directly by computing the eigenvalues of the matrix $(A - BK)$.

Conclusion 1. *Based on Equation (4), a large number of control laws can be suggested. For instance, the control laws used in (Wang, 1994) and (Wang, 1993), as well as the control law proposed in Equation (7) are particular cases of Equation (4).*

Remark 2. *Without loss of generality, $r = 0$ is considered for stability analysis and the nominal system is considered to be of the form*

$$\dot{x} = (A - BK)x \quad (9)$$

4. Mathematical requirements for fuzzy logic control application

4.1 Fuzzy structure

Since the fuzzy logic was proposed by L.A. Zadeh (Zadeh, 1965), a lot of different fuzzy inference engines have been suggested. Other researchers have also been used with success in a variety of applications for control of nonlinear systems (e.g.: (Han, 2005; Jang et al., 1997; Lin & Lee, 1995; Nauck et al., 1997; Pan et al., 2009; Predrycz & Gomide, 1999; Tong et al., 2011; Tsoukalas & Uhrig, 1997; Yoneyama & Júnior, 2000)). Based on previous researches (Sugeno & Kang, 1988; Takagi & Sugeno, 1985), which propose the Takagi-Sugeno-Kang fuzzy structure (TSK), this work makes use of a fuzzy logic system with product-inference rule, center average defuzzifier, and Gaussian membership functions.

Consider singleton fuzzifier and let a fuzzy system be composed by R rules, each one of them of the form

$$\text{IF } x_1 \text{ is } A_1^j \text{ and } x_n \text{ is } A_n^j \text{ THEN } y \text{ is } B_j \quad (10)$$

where $x = [x_1, \dots, x_n] \in \mathfrak{R}^n$ is the input vector, $\{A_1^j, \dots, A_n^j\} / B_j$ are the input/output fuzzy sets related to the j^{th} rule ($j = 1, \dots, R$), and y is the fuzzy output.

Consider y_j as the point in which B_j is maximum ($\mu_{B_j}(y_j) = 1$) and define θ as the vector of parameters of the form

$$\theta^T = [y_1, \dots, y_R] \quad (11)$$

Therefore, the fuzzy output can be expressed as

$$y = \theta^T \cdot W(x) \quad (12)$$

where

$$W(x) = [W_1(x), \dots, W_R(x)]^T$$

$$W_j(x) = \frac{\prod_{k=1}^n \mu_{A_k^j}(x_k)}{\sum_{j=1}^R \left(\prod_{k=1}^n \mu_{A_k^j}(x_k) \right)}, \quad j = 1 \dots R \quad (13)$$

and

$$W_j(x) \in [0, 1] \tag{14}$$

is usually called the *weight* of the j^{th} rule. The scheme is shown in Figure (2).

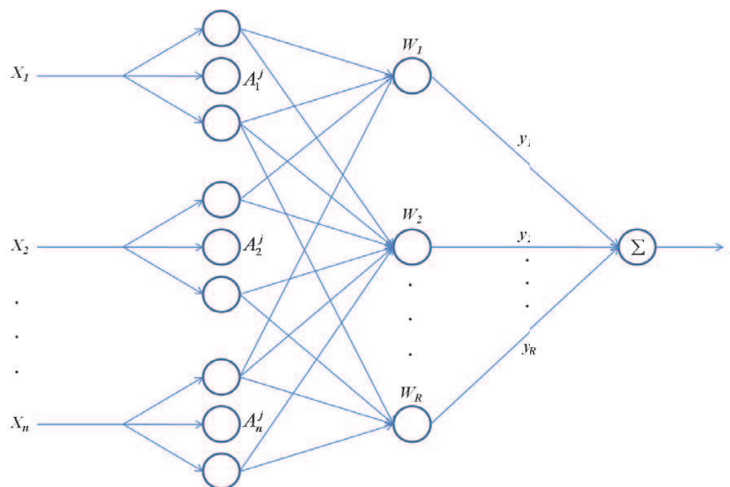

Fig. 2. Zero-order TSK fuzzy structure

4.2 Fuzzy as universal approximators

For any given real continuous function $f(x)$ on a compact set $x \in X \subset \mathbb{R}^n$ and arbitrary $\epsilon > 0$, there exists a fuzzy logic system $f(x|\theta^*)$ in the form of Equation (12) such that

$$\max_{x \in X} |f(x) - f(x|\theta^*)| < \epsilon, \forall x \tag{15}$$

Remark 3. Proof of this theorem is available in (Wang, 1994).

This work follows the classical work by Wang Wang (1993), Wang (1994) and some of related papers (e.g.: Fischle & Schroder (1999); Gazi & Passino (2000); Lee & Tomizuka (2000); Tong et al. (2000)). Most of these works involve fuzzy estimators in order to approximate nonlinear functions which appear in the model describing the plant. The fuzzy estimates are then used in the control law which may, for instance, be based on the exact feedback linearization techniques. However, it is shown by an example that the convergence of the estimates may not be achieved, even though the system exhibits good reference tracking properties. The new approach proposed in this work is thus aimed at obtaining convergence of the estimates of the nonlinear functions which are modelled by fuzzy structures.

Notice that the control law in Equation (7) can not be implemented because the functions $f(x)$ and $g(x)$ are unknown and must be estimated. The idea is to construct fuzzy structures to generate the estimates $f(x|\hat{\theta}_f)$ and $g(x|\hat{\theta}_g)$, where $\hat{\theta}_f$ and $\hat{\theta}_g$ are the respective vector of parameters.

In this work, Equation (1) uses the fuzzy structures of form

$$\begin{aligned} f(x|\hat{\theta}_f) &= \hat{\theta}_f^T W(x) \\ g(x|\hat{\theta}_g) &= \hat{\theta}_g^T W(x) \end{aligned} \tag{16}$$

where $W(x)$ is associated with the antecedent part of the rules (see 13). Moreover, the parameters $\hat{\theta}_f$ and $\hat{\theta}_g$ are (see 12) obtained using an adaptation scheme. Thus, the implementable version of the control law in Equation (7) becomes

$$u = \frac{1}{g(x|\hat{\theta}_g)} \left[-f(x|\hat{\theta}_f) + r - Kx \right] \quad (17)$$

5. The proposed control structure

A control method is proposed here by introducing equations that are analogous to those of state observers but with $f(x)$ and $g(x)$ replaced by corresponding fuzzy approximations

$$\dot{x}_f = Ax_f + B \left(f(x|\hat{\theta}_f) + g(x|\hat{\theta}_g)u \right) + k^T C \left(x - x_f \right) \quad (18)$$

where k is a gain vector of the form

$$k = [k_1, \dots, k_n] \in R^n \quad (19)$$

Remark 4. From Equation (2), it can be noticed that the pair (A, C) is observable.

5.1 Target Parameters

Fuzzy approximators possess universal approximation properties (see, for instance, (Wang, 1994; Ying, 1998; Ying et al., 1997)). Thus, given $\varepsilon_f, \varepsilon_g > 0$ there exist target parameters θ_f^* and θ_g^* such that

$$\begin{cases} |f(x|\theta_f^*) - f(x)| < \varepsilon_f & \forall x \in X \\ |g(x|\theta_g^*) - g(x)| < \varepsilon_g & \forall x \in X \end{cases} \quad (20)$$

where X is the input universe of discourse and $\varepsilon_f, \varepsilon_g > 0$ are arbitrary positive constants. Hence, the real system (1) can be approximated by a model based on fuzzy structures up to the required precision by choosing ε_f and ε_g . Let the target fuzzy system be described by

$$\dot{x}_f^* = Ax_f^* + B \left(f(x|\theta_f^*) + g(x|\theta_g^*)u \right) + k^T C \left(x - x_f^* \right) \quad (21)$$

If the parameters of the target model were available, then Equation (17) could be used to produce an approximating control law of the form

$$u = \frac{1}{g(x|\theta_g^*)} \left[-f(x|\theta_f^*) + r - Kx \right] \quad (22)$$

In the present approach, θ_f^* and θ_g^* are replaced by estimates $\hat{\theta}_f$ and $\hat{\theta}_g$ obtained by an adaptative scheme. Later, it will be shown that, under appropriate conditions, $\hat{\theta}_f \rightarrow \theta_f^*$, $\hat{\theta}_g \rightarrow \theta_g^*$.

In order to establish, initially, the stability properties of the control based on the target model, consider $r = 0$ without loss of generality. Inserting Equation (22) into Equation (1) one obtains that

$$\dot{x} = Ax + B \left[f(x) - g(x) \frac{1}{g(x|\theta_g^*)} \left[f(x|\theta_f^*) + Kx \right] \right] \quad (23)$$

which can be rewritten as

$$\dot{x} = (A - BK)x + \lambda(x, \theta_f^*, \theta_g^*) \tag{24}$$

where $\lambda(x, \theta_f^*, \theta_g^*)$ is given by

$$B \left[f(x) - g(x) \frac{1}{g(x|\theta_g^*)} [f(x|\theta_f^*) + Kx] + Kx \right] \tag{25}$$

Now, given a $\delta > 0$, it is possible to choose ε_f and ε_g in Equation (20) so that for fixed target values θ_f^* and θ_g^* one has

$$\|\lambda(x, \theta_f^*, \theta_g^*)\| < \delta \quad \forall x \in X \tag{26}$$

If θ_f^* and θ_g^* corresponded to the situation of exact matching, then $\lambda(0, \theta_f^*, \theta_g^*) = 0$ and $\lambda(x, \theta_f^*, \theta_g^*)$ would be a vanishing perturbation so that Lemma 5.1 in Chapter 5 of (Khalil, 2001) could be applied to establish exponential stability. In general, the universal approximation properties of fuzzy structures only guarantees Equation (20) with $\varepsilon_f, \varepsilon_g > 0$. Therefore, one requires Theorem 5.1 in Chapter 5 of (Khalil, 2001) which ensures that $x(t)$ does not escape a region

$$\|x(t)\| \leq \beta(x(t_0), t - t_0) \tag{27}$$

where $\beta(\cdot, \cdot)$ is a class of *KL* function.

5.2 Estimation errors

Define the estimation error vector by

$$e = x_f^* - x_f = [e_1 \ e_2 \ \dots \ e_n]^T \tag{28}$$

Subtracting Equation (18) from Equation (21) one gets

$$\begin{aligned} \dot{e} = & (A - k^T C) e + \\ & + B [f(x|\theta_f^*) - f(x|\hat{\theta}_f) + (g(x|\theta_g^*) - g(x|\hat{\theta}_g)) u] \end{aligned} \tag{29}$$

For the sake of simplicity, introduce the notation

$$\dot{e} = \Lambda e + \rho \tag{30}$$

where

$$\begin{aligned} \Lambda = & (A - k^T C) \\ \rho = & B [f(x|\theta_f^*) - f(x|\hat{\theta}_f) + (g(x|\theta_g^*) - g(x|\hat{\theta}_g)) u] \end{aligned} \tag{31}$$

Because Λ is a stable matrix, there exists an unique positive definite and symmetric matrix $P_{n \times n}$, which satisfies the Lyapunov equation

$$\Lambda^T P + P \Lambda = -Q \tag{32}$$

where $Q_{n \times n}$ is an arbitrary positive definite matrix.

5.3 Adaptation law and convergence analysis

The target estimates θ_f^* and θ_g^* are not known a priori. Therefore, adaptation laws must be provided in order to force $\hat{\theta}_f \rightarrow \theta_f^*$, $\hat{\theta}_g \rightarrow \theta_g^*$ and $e \rightarrow 0$.

Following (Wang, 1997), adopt as a candidate function in the sense of Lyapunov

$$V = \frac{1}{2} e^T P e + \frac{1}{2\gamma_f} \phi_f^T \phi_f + \frac{1}{2\gamma_g} \phi_g^T \phi_g \quad (33)$$

where

$$\begin{aligned} \phi_f &= \theta_f^* - \hat{\theta}_f & \text{and} & & \dot{\phi}_f &= -\dot{\hat{\theta}}_f \\ \phi_g &= \theta_g^* - \hat{\theta}_g & \text{and} & & \dot{\phi}_g &= -\dot{\hat{\theta}}_g \end{aligned} \quad (34)$$

and γ_f, γ_g are positive constants.

The time-derivative is of the form

$$\dot{V} = \frac{1}{2} (e^T P \dot{e} + e^T P \dot{e}) - \frac{1}{\gamma_f} \phi_f^T \dot{\hat{\theta}}_f - \frac{1}{\gamma_g} \phi_g^T \dot{\hat{\theta}}_g \quad (35)$$

and an interesting choice for the adaptation laws are

$$\begin{aligned} \dot{\hat{\theta}}_f &= -\gamma_f e^T P B W(x) \\ \dot{\hat{\theta}}_g &= -\gamma_g e^T P B W(x) u \end{aligned} \quad (36)$$

In fact, using the adaptation laws 36 each term of Equation (35) can be rewritten as

$$\begin{cases} \frac{1}{2} (e^T P \dot{e} + e^T P \dot{e}) = -\frac{1}{2} e^T Q e + e^T P \rho \\ \frac{1}{\gamma_f} \phi_f^T \dot{\hat{\theta}}_f = e^T P B (f(x|\theta_f^*) - f(x|\hat{\theta}_f)) \\ \frac{1}{\gamma_g} \phi_g^T \dot{\hat{\theta}}_g = e^T P B (g(x|\theta_g^*) - g(x|\hat{\theta}_g)) u \end{cases} \quad (37)$$

and Equation (35) becomes

$$\dot{V} = -\frac{1}{2} e^T Q e \quad (38)$$

which is negative semi-definite.

Conclusion 5. A semi-negative definition of Equation (38) guarantees that the error e is bounded. The application of the Barbalat's Lemma yields that $e \rightarrow 0$ when $t \rightarrow \infty$. From Equation (28), $e \rightarrow 0$ implies that $x_f \rightarrow x_f^*$ and the convergence of the parameter estimates to their respective target values is obtained.

6. Simulation results

Considering that a magnetic levitation system is available at the Control Lab of CTAI, it may represent future opportunities for continued researches with hands on experimentation. Hence it is selected as the system which will be used here as an example to illustrate the method. The scheme is presented in Figure (3) and the aim in this problem is to suspend an

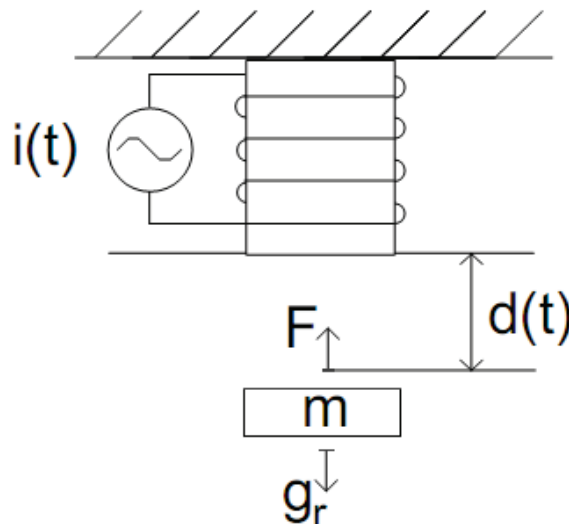

Fig. 3. Magnetic levitation system

iron mass by adjusting the current in a coil. It is nonlinear and open-loop unstable. Also note that the magnetic field is not uniform and the attraction force is nonlinear.

A model for this system is

$$\ddot{d} = g_r - \frac{F}{m} \tag{39}$$

where m is the mass of the disc, g_r is the gravitational acceleration and F is the electromagnet force produced by a coil fed with current i

$$F = c \frac{i^2}{d^2} \tag{40}$$

with c a positive constant, and d the position of the disc.

Denoting by $x_1 = d$ and $x_2 = \dot{d}$ the components of the state vector and combining Equations (39) and (40) one may write

$$\begin{cases} \dot{x}_1 = x_2 \\ \dot{x}_2 = g_r - c \frac{i^2}{m.x_1^2} \end{cases} \tag{41}$$

Hence, comparison with Equation (1) yields the following association

$$\begin{aligned} f(x) &= g_r \\ g(x) &= -c \frac{1}{m.x_1^2} \\ u &= i^2 \end{aligned} \tag{42}$$

For simulation results, this work adopted the following values for the model parameters

$$\begin{aligned} c &= 0.15 [Nm/A^2] \\ m &= 0.12 [kg] \\ g_r &= 9.81 [m/s^2] \end{aligned} \tag{43}$$

The free parameters are chosen as follows:

$$\begin{aligned} K &= [1 \ 1] \\ k &= [50 \ 100] \\ \gamma_g &= 10^4 \end{aligned} \quad (44)$$

For the initial condition of the nonlinear system let $d(0) = x_1(0) = 1.2$ and $x_2(0) = 0$. The initial conditions for the fuzzy estimates are zero.

Choosing Q as the identity matrix, Equation (32) leads to

$$P = \begin{bmatrix} 1.2550 & 0.0100 \\ 0.0100 & 0.0051 \end{bmatrix} \quad (45)$$

From practical inspection of the actual experimental setup, let the range of $d(t)$ be $Rx_1 = [0.6, 3.4]$, which represents the fuzzy input universe of discourse. Also define

$$g^L(x) = -\frac{c}{m [\max(Rx_1)]^2} \quad (46)$$

as the lower bound of $|g(x|\hat{\theta}_g)|$, which also guarantees that $|g(x|\hat{\theta}_g)| \neq 0$.

Choosing the vector Xc of the centers of the membership functions as given by

$$Xc = [0.6 \ 0.8 \ 1.0 \ 1.2 \ 1.4 \ 1.8 \ 2.2 \ 2.6 \ 3.0 \ 3.4]^T \quad (47)$$

one gets membership functions for the sets A^j as shown in Figure (4).

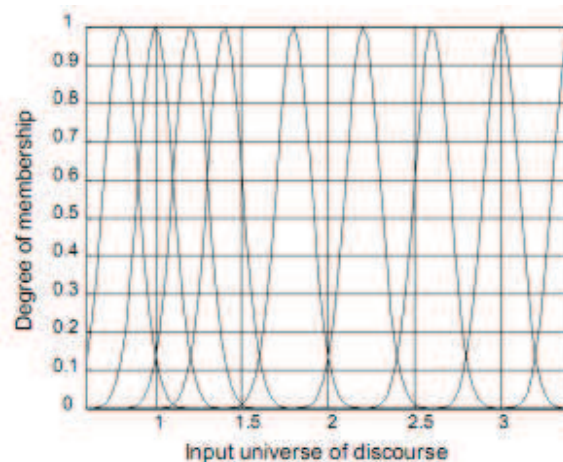

Fig. 4. Membership functions

Remark 6. This fuzzy input universe of discourse is desired in this application since the magnetic force increases with second power of d (situation that may put in risk the controller in experimental tests).

For each $t \in \mathfrak{R}$ and fuzzy set A^j , define a single rule of the form

$$\text{IF } d(t) \text{ is } A^j \text{ THEN } y \text{ is } y_j \quad j = 1 \dots R \quad (48)$$

where $R = \text{length}(Xc)$.

In order to compute the target values of θ_g^* , not available in practical situation, but useful in simulation purposes to evaluate the method, note that rules can be generated simply by computing the real value of the function $g(x|\hat{\theta}_g)$ as

$$y_j = -\frac{c}{m(Xc_j)^2}, \quad j = 1 \dots R \tag{49}$$

As for the actual initialization of the vector $\hat{\theta}_g$ one can use randomly generated values such as

$$\theta_g^* = \begin{bmatrix} -55.5556 \\ -31.2500 \\ -20.0000 \\ -13.8889 \\ -10.2041 \\ -6.1728 \\ -4.1322 \\ -2.9586 \\ -2.2222 \\ -1.7301 \end{bmatrix}, \quad \theta_g = \begin{bmatrix} 9.7945 \\ -2.6561 \\ -5.4837 \\ -0.9627 \\ -13.8067 \\ -7.2837 \\ 18.8600 \\ -29.4139 \\ 9.8002 \\ -11.9175 \end{bmatrix} \tag{50}$$

Remark 7. The randomized initialization of θ_g must satisfy the constraint $|g^L(x)| \leq |g(x|\hat{\theta}_g)|$ and the sign of $g(x|\hat{\theta}_g)$ must be equal to the sign of $g(x)$.

Let the reference signal $r(t)$ be a square wave in the range 1.2 to 2.8 . Figures from (5) to (8) present the obtained simulation results. The nominal case corresponds to the situation with real $f(x)$ and $g(x)$.

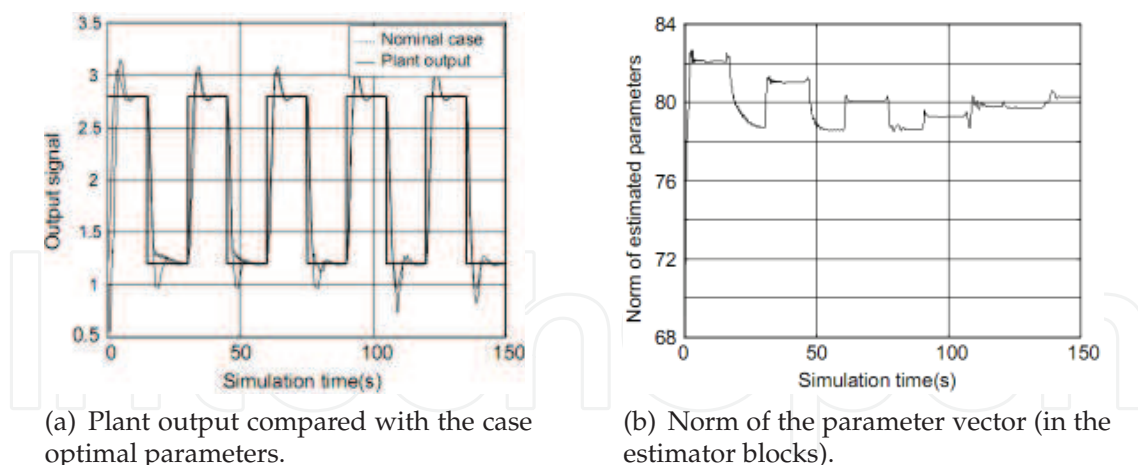

Fig. 5. Simulation Results

It could be observed in Figure (5(a)) that the reference signal $r(t)$ was tracked by the plant output. The magnetic disc position (process variable) could be observed in Figure (5(a)) with some oscillations but bounded and stable in steady state. The adaptive scheme used here provides the real convergence of the estimates $f(x|\hat{\theta}_f)$ and $g(x|\hat{\theta}_g)$ to their optimal values $f(x|\theta_f^*)$ and $g(x|\theta_g^*)$ while keeping the estimation errors with respect to a reference signal within a compact set (according to Figures (8(a)) and (8(b))). The control effort u associated with the electrical current is bounded as shown in Figure (6(a)).

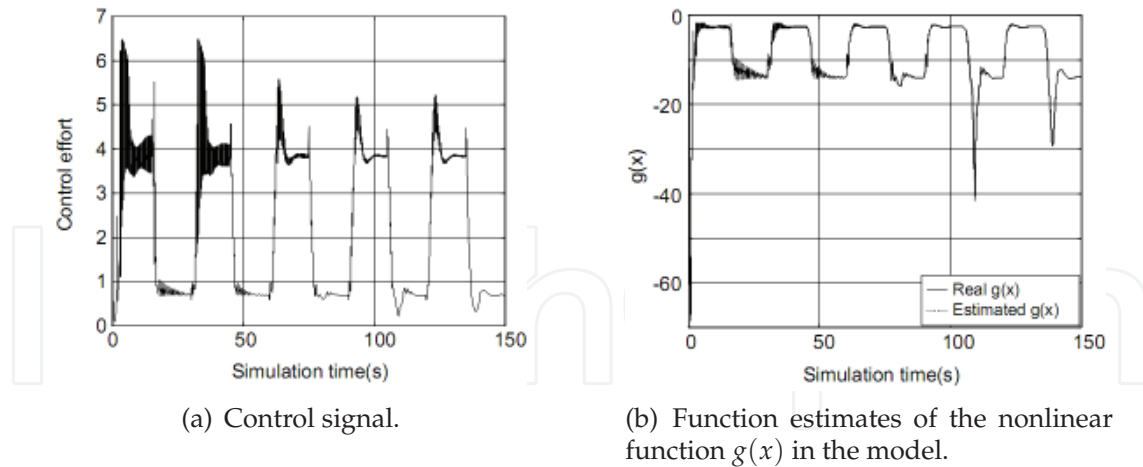

Fig. 6. Simulation Results

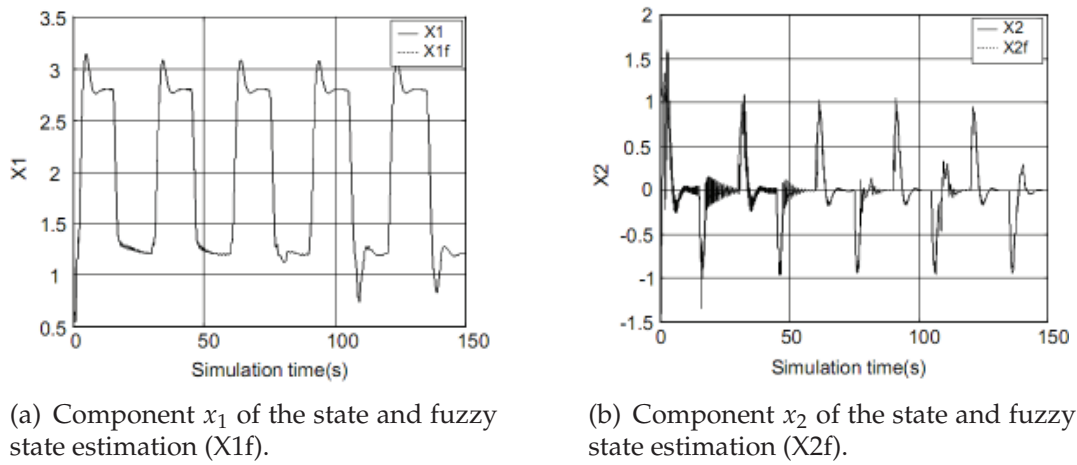

Fig. 7. Simulation Results

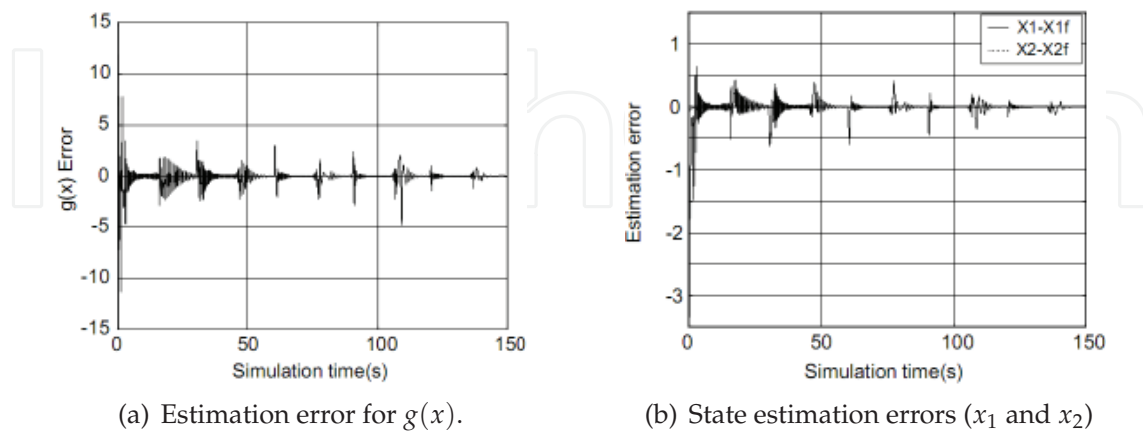

Fig. 8. Simulation Results

It is worth noticing in Figures (6(b)), (7(a)) and (7(b)) that the function estimates converge to their real values and, in turn, they force the system to reproduce the nominal case as proposed

in Equation (4) where the knowledge of $f(x)$ and $g(x)$ are considered.

7. Experimental tests

7.1 Magnetic levitation

The magnetic levitation test bed supplied by ECP Model 730 (see (ECP, 1999)) which is used for these experiment tests is shown in Figure (9).



Fig. 9. Practical setup of magnetic levitation system ECP Model 730 ECP (1999)

The plant shown in Figure (10), consists of upper and lower coils that produce a magnetic field in response to a DC current. One or two magnets travel along a precision ground glass guide rod. By energizing the lower coil, a single magnet is levitated through a repulsive magnetic force. As the current in the coil increases, the field strength increases and the levitated magnet height is increased. For the upper coil, the levitating force is attractive. Two magnets may be controlled simultaneously by stacking them on the glass rod. The magnets are of an ultra-high field strength rare earth (NeBFe) type and are designed to provide large levitated displacements to clearly demonstrate the principle of levitation and motion control. Two laser-based sensors measure the magnet positions. The lower sensor is typically used to measure a given position of the magnet in proximity to the lower coil, and the upper one for proximity to the upper coil. This proprietary ECP sensor design utilizes light amplitude measurement and includes special circuitry to desensitize the signal to stray ambient light and thermal fluctuations.

The Magnetic Levitation setup apparatus dramatically demonstrates closed loop levitation of permanent and ferro-magnetic elements. The apparatus includes laser feedback and high flux magnetics to affect large displacements and provide visually stimulating tracking and regulation demonstrations. The system is quickly set up in the open loop stable and unstable (repulsive and attractive fields) configurations as shown in Figures (9) and (10). By adding a second magnet, two SIMO plants may be created, and by driving both actuators with both magnets, MIMO control is studied. The field interaction between the two magnets causes strong cross coupling and thus produces a true multi-variable system. The inherent magnetic field nonlinearities may be inverted via provided real-time algorithms for linear control implementation or the full system dynamics may be studied.

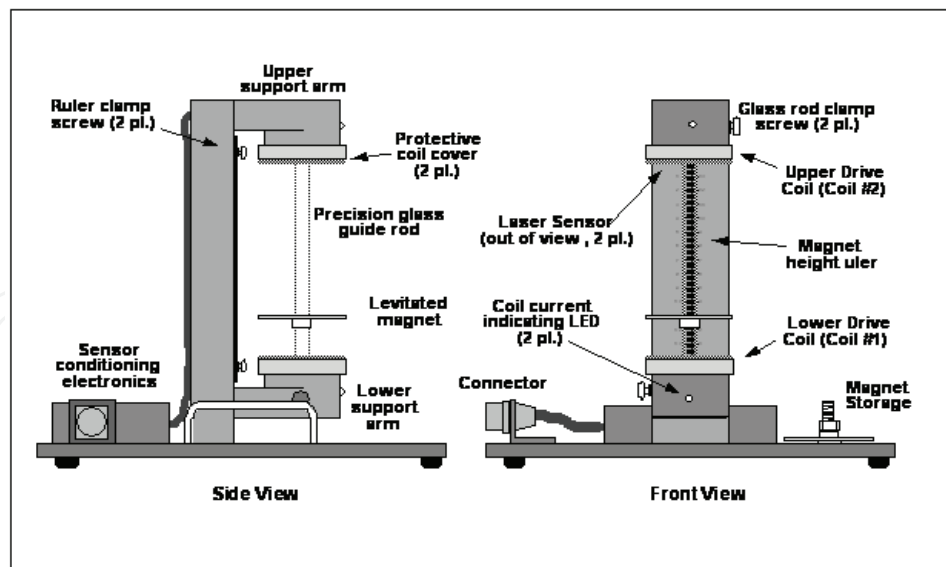

Fig. 10. Side and front view of magnetic levitation system ECP (1999)

The complete experimental setup is comprised of the three subsystems as shown in Figure (11) (from right to left):

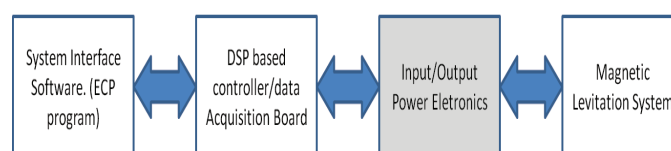

Fig. 11. Block diagram of experimental control system

1. The first subsystem is the Magnetic Levitation system itself (described above) which consists of the electromagnetic coils, magnets, high resolution encoders.
2. The next subsystem is the real-time controller unit that contains the Digital Signal Processor (DSP) based real-time controller, servo/actuator interfaces, servo amplifiers, and auxiliary power supplies. The DSP is capable of executing control laws at high sampling rates allowing the implementation to be modeled as continuous or discrete time systems. The controller also interprets trajectory commands and supports such functions as data acquisition, trajectory generation, and system health and safety checks.
3. The third subsystem is the executive program which runs on a PC under the Windows operating system. This menu-driven program is the user's interface to the system and supports controller specification, trajectory definition, data acquisition, plotting, system execution commands, and more. Controllers may assume a broad range of selectable block diagram topologies and dynamic order. The interface supports an assortment of features which provide a friendly yet powerful experimental environment. Real-time implementation of the controllers is also possible using the Real Time Windows Target (RTWT).

7.2 Experimental method

Following some related works with using the ECP Model 730 (Nataraj & Mukesh, 2008; 2010), the steps followed to carry out the experiment are as follows:

1. Linearization of the sensor (see (ECP, 1999, p. 81)) with the following values:

$$\begin{aligned} e &= 115720000; \\ f &= 7208826; \\ g &= 30540; \\ h &= 0.2411. \end{aligned} \tag{51}$$

2. Nonlinear compensation of the actuator (see (ECP, 1999, p. 81)) with the following values:

$$\begin{aligned} a &= 1.0510^{-4}; \\ b &= 6.2. \end{aligned} \tag{52}$$

3. Construct the design control system in Simulink environment as shown in Figure (12) along with reference command signal. Figure (13) shows the inside view of "Adaptive Fuzzy Controller" block;

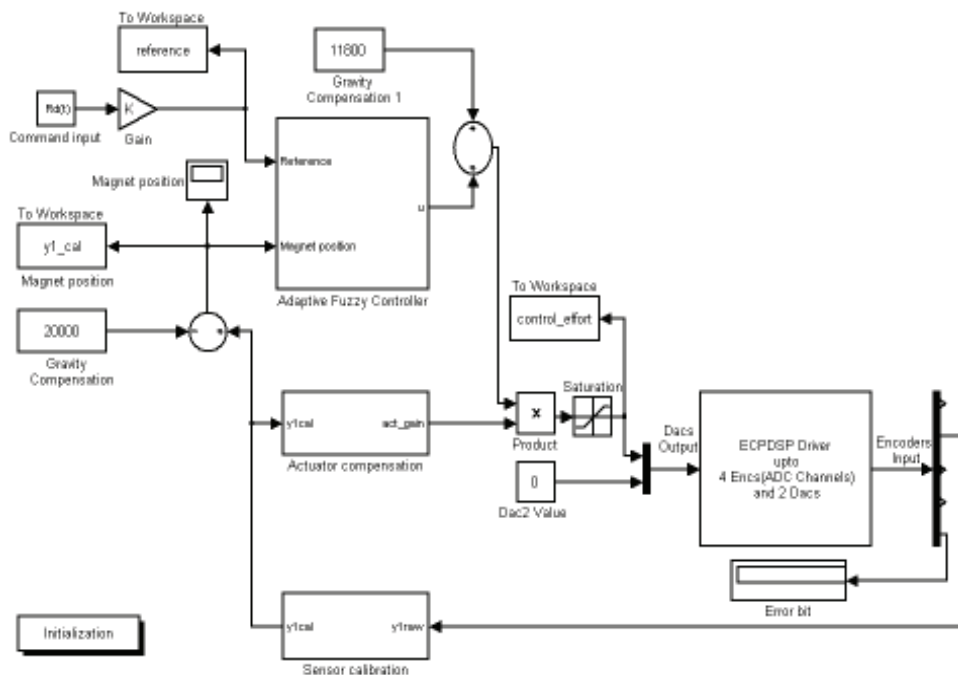

Fig. 12. The simulation block diagram used for RTWT

4. Build and execute the real time model using Real Time Windows Target(RTWT), to convert the control algorithm in C++ code. Download this code onto the DSP via RTWT;
5. Start the real-time implementation from within RTWT environment for desired length of time;
6. After the experiment is over, make the appropriate conversions and plot the data.

For experimental tests, this work adopted the following values for the plant parameters (see (ECP, 1999)):

$$\begin{aligned} c &= 0.15 [Nm/A^2] \\ m &= 0.12 [kg] \\ g_r &= 9.81 [m/s^2] \end{aligned} \tag{53}$$

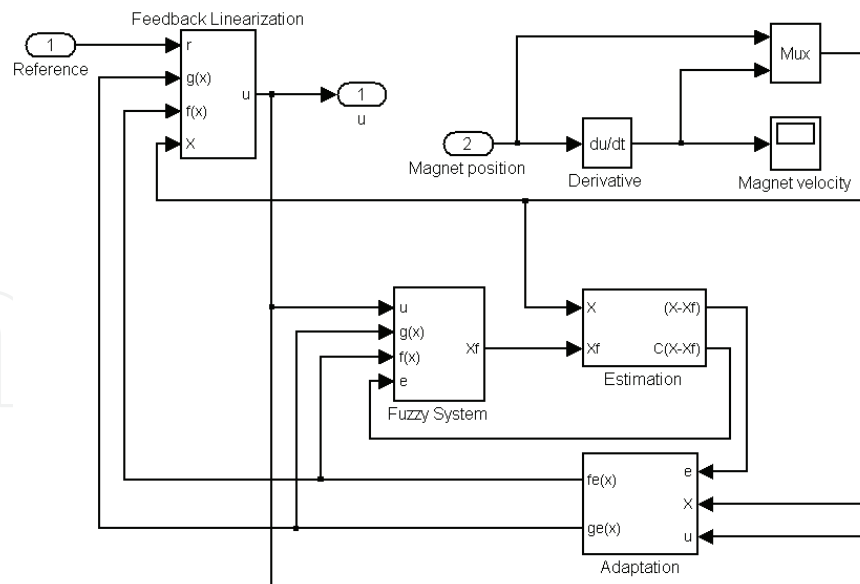

Fig. 13. Adaptive fuzzy controller

7.3 Experimental results

The adaptive fuzzy control system proposed in Section 5 is now implemented real time and experimentally tested for its performance. Initially, the magnet is brought to equilibrium position of 2cm as plant is linearized to 2cm. The upper coil (attractive force) was used with one magnet. Therefore, an open-loop unstable SISO system was implemented and tested with the designed controller. Now the reference signal is applied.

The response of the closed loop system for a given reference command signal is shown in Figure (14). The experimental results show that a reference input signal was tracked by the controller output signal while keeping the tracking error with respect to a reference signal within a compact set (Figure (15)). The required control effort is low, with a peak of 6.5 volts (see Figure (16)).

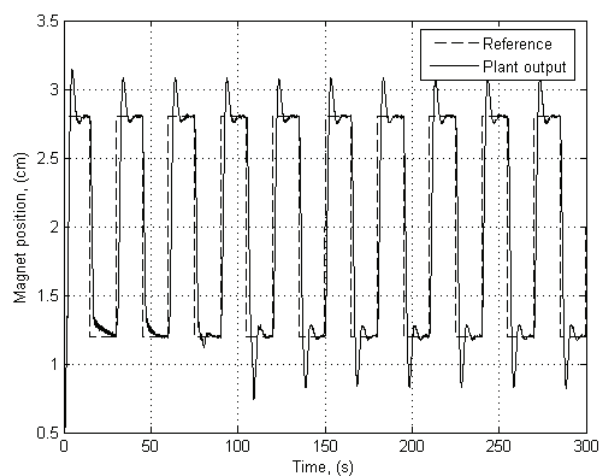

Fig. 14. Step response of closed loop system

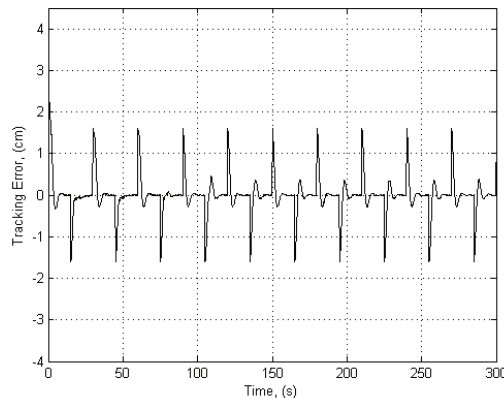

Fig. 15. Tracking Error

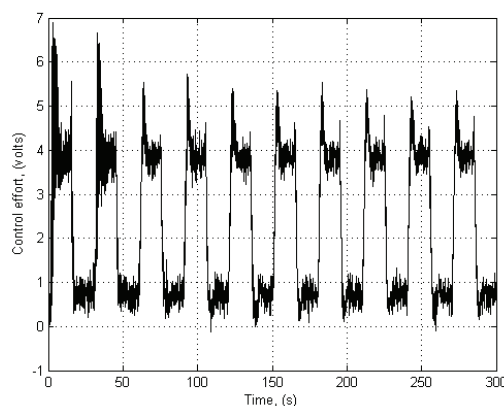

Fig. 16. Control effort required to levitate the magnet

8. Conclusions

The adaptive control scheme presented in this work considers the difference between the nonlinear system and an associated dynamic system using fuzzy estimates. The model of the associated dynamics is analogous to that of state observers but using fuzzy structures to estimate the nonlinear functions. If optimal parameters are considered, then the stability may be investigated using a classical method of perturbed system. Thus, since adequate fuzzy structures are used stability is assured when optimal parameters are considered. A Lyapunov function is then used in order to show the convergence of the estimates to their respective optimal values. Hence, when the fuzzy structures are carefully chosen, the estimates approach optimal values which may be arbitrarily close to the true values.

In some previous work, successful results have been attributed to nonlinear approximators such as fuzzy or neural blocks. However, the proof of the estimates convergence had not been presented. Moreover, the adaptation law does not force the convergence of the estimates. In these previous results, the robustness of the tracking error is reached as a consequence of the application of the tracking control theory. It keeps the error in a compact set without requiring the convergence of the estimates to their real values. It is important to mention that the real convergence of the estimates represents the most significant contribution of this work. The error analysis is analogous to the previous work, but a new scheme for the adaptive fuzzy control was proposed. Differently from previous research, the adaptation laws force the

convergence of the function estimates. Moreover, although the tracking error is not considered to be of primary concern, it is obtained as a consequence of the proposed control law when the convergence of the estimates is attained.

The proposed adaptive controller is tested on ECP Model 730 Magnetic Levitation setup through Real Time Windows Target (RTWT). It has been successfully applied to experimental Magnetic Levitation setup and desired reference tracking properties are also achieved. Therefore, the experimental tests show the reliability and robustness of the proposed algorithm.

9. Future contributions

One of the most important contributions of this work is a new approach for designing of adaptive control techniques based on intelligent estimators which may be either fuzzy or neural. The continuation of this research may lead to:

- a. The analysis of the proposed method in other nonlinear systems;
- b. The application of the proposed method with artificial neural networks as estimators;
- c. The generalization of the obtained results for a larger class of nonlinear systems;
- d. Analysis of the proposed method in other practical applications.

10. Acknowledgement

The authors wish to acknowledge the support with facilities and infrastructure from CTAI at Universidade Federal da Bahia and CAPES for the financial support.

11. References

- Cavalcante, M. D., Costa, A. C. P. L. d. & Schnitman, L. (2008). An intelligent adaptive controller, *Proceedings of 5th Latin American Robotics Symposium*.
- ECP (1999). *Educational Control Products - Manual for Model 730*, California, USA.
- Fischle, K. & Schroder, D. (1999). An improved stable adaptive fuzzy control method, *IEEE Trans. on Fuzzy Systems* 7: 27–40.
- Gazi, V. & Passino, K. M. (2000). Direct adaptive control using dynamic structure fuzzy systems, *Proceedings of American Control Conference*, Vol. 3, pp. 1954–1958.
- Ghaebi, P. P., Ataei, M. & Shafiei, A. (2011). An adaptive fuzzy sliding mode control of a permanent magnet linear synchronous motor for an inimal command velocity profile, *Proceedings of IEEE International Conference on System Engineering and Technology, ICSET*, pp. 41–46.
- Han, H. (2005). Adaptive fuzzy controller for a class of nonlinear systems, *International Journal of Innovative Computing, Information and Control* 1(2): 727–742.
- Isidori, A. (1995). *Nonlinear Control Systems*, 3rd edn, Springerl. ISBN-13: 978-1852331887.
- Islam, S. & Liu, P. X. (2011). Robust adaptive fuzzy output feedback control system for robot manipulators, *IEEE/ASME Transactions on Mechatronics* 16(2): 288–296.
- Jang, J.-S. R., Sun, C.-T. & Mizutani, E. (1997). *Neuro-fuzzy and soft computing, ĀĀĀ*, Prentice Hall.
- Kaloust, J., Ham, C., Siehling, J., Jongekryg, E. & Han, Q. (2004). Nonlinear robust control design for levitation and propulsion of a maglev system, *IEE Proc.-Control Theory Appl.* 151(4). doi: 10.1049/ip-cta:20040547.

- Khalil, H. K. (2001). *Nonlinear Systems*, 3rd edn, Prentice Hall.
- Lee, H. & Tomizuka, T. (2000). Robust adaptive control using a universal approximator for siso nonlinear systems, *IEEE Trans. on Fuzzy Systems* 8: 95–106.
- Lin, C.-T. & Lee, C. S. G. (1995). *Neural Fuzzy Systems: A Neuro-Fuzzy Synergism to Intelligent Systems*, Prentice Hall.
- Nataraj, P. S. V. & Mukesh, D. P. (2008). Robust control design for nonlinear magnetic levitation system using quantitative feedback theory (qft), *Proceedings of Annual IEEE India Conference, INDICON 2008*, Bombay, India, pp. 365–370. d.o.i: 10.1109/INDCON.2008.4768751.
- Nataraj, P. S. V. & Mukesh, D. P. (2010). Nonlinear control of a magnetic levitation system using quantitative feedback theory (qft), *Proceedings of 2nd International Conference on Reliability, Safety and Hazard - ICRESH-2010*, Mumbai, India, pp. 542–547. d.o.i: 10.1109/ICRESH.2010.5779608.
- Nauck, D., Klawonn, F. & Kruse, R. (1997). *Foundations of Neuro-Fuzzy Systems*, John Wiley.
- Nauck, D., Klawonn, F. & Kruse, R. (2009). *Modern Control Engineering*, 5th edn, Prentice Hall. ISBN-13: 978-0136156734.
- Pan, Y., Huang, D. & Sun, Z. (2009). Indirect adaptive fuzzy control with approximation error estimator for nonlinear systems, *Proceedings of 2nd International Conference on Intelligent Computing Technology and Automation, ICICTA 2009*, pp. 748–751.
- Predrycz, W. & Gomide, F. A. C. (1999). *An Introduction to Fuzzy Sets Analysis and Design*, MIT Press.
- Schnitman, L. (2001). *Intelligente controller for dynamic systems with state and input constraints and subjected to model uncertainties*, PhD thesis, ITA - Instituto Tecnológico da Aeronáutica.
- Slotine, J.-J. E. & Li, W. (1991). *Applied Nonlinear Control*, Prentice Hall.
- Sontag, E. D. (1998). *Mathematical Control Theory: Deterministic Finite Dimensional Systems*, 2nd edn, Springer. ISBN 0-387-984895.
- Sugeno, M. & Kang, G. (1988). Structure identification of fuzzy model, *Fuzzy Sets and Systems* 28: 15–33.
- Takagi, T. & Sugeno, M. (1985). Fuzzy identification on systems and its applications to modeling and control, *IEEE Trans. on Systems, Man, and Cybern.* 15(2): 116–132.
- Toha, S. F. & Tokhi, M. O. (2009). Dynamic nonlinear inverse-model based control of a twin rotor system using adaptive neuro-fuzzy inference system, *Proceedings of EMS 2009 - UKSim 3rd European Modelling Symposium on Computer Modelling and Simulation*, pp. 107–111.
- Tong, S., Liu, C. & Li, Y. (2011). Adaptive fuzzy backstepping output feedback control for strict feedback nonlinear systems with unknown sign of high-frequency gain, *Neurocomputing*. ISSN: 09252312.
- Tong, S., Wang, T. & Tang, J. T. (2000). Fuzzy adaptive output tracking control of nonlinear systems, *Fuzzy Sets and Systems* 15(3): 674–692. doi: 10.1109/TNN.2004.826130.
- Torres, L. H. S., Vasconcelos Júnior, C. A. V., Schnitman, L. & Felipe de Souza, J. A. M. (2010). Feedback linearization and model reference adaptive control of a magnetic levitation system, *Proceedings of Latin American Control Conference, LACC 2010*.
- Tsoukalas, L. H. & Uhrig, R. E. (1997). *Fuzzy and Neural Approaches in Engineering*, John Wiley.
- Wang, L.-X. (1993). Stable adaptive fuzzy control of nonlinear systems, *IEEE Trans. on Fuzzy Systems* 1(2): 146–155.
- Wang, L.-X. (1994). *Adaptive Fuzzy Systems and Control*, Prentice Hall.
- Wang, L.-X. (1997). *A Course in Fuzzy Systems and Control*, Prentice Hall.

- Yang, Z. J. & M., T. (2001). Adaptive robust nonlinear control of a magnetic levitation system, *Automatica* (37): 1125–1131.
- Ying, H. (1998). General SISO takagi-sugeno fuzzy systems with linear rule consequent are universal approximators, *Proceedings of IEEE Int. Conf. on Systems, Man and Cybern.*, pp. 582–587.
- Ying, H., Ding, Y. & Shao, S. (1997). Necessary conditions for general MISO fuzzy systems as universal approximators, *Proceedings of IEEE Int. Conf. on Systems, Man and Cybern.*
- Yoneyama, T. & Júnior, C. L. N. (2000). *Inteligência Artificial Em Automação e Controle*, Edgard Blucher.
- Zadeh, L. A. (1965). Fuzzy sets, *Information and Control* 8: 338–353.

IntechOpen

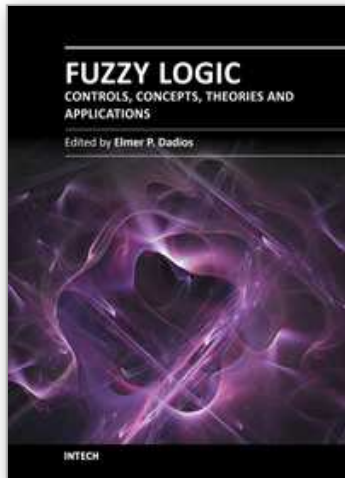

Fuzzy Logic - Controls, Concepts, Theories and Applications

Edited by Prof. Elmer Dadios

ISBN 978-953-51-0396-7

Hard cover, 428 pages

Publisher InTech

Published online 28, March, 2012

Published in print edition March, 2012

This book introduces new concepts and theories of Fuzzy Logic Control for the application and development of robotics and intelligent machines. The book consists of nineteen chapters categorized into 1) Robotics and Electrical Machines 2) Intelligent Control Systems with various applications, and 3) New Fuzzy Logic Concepts and Theories. The intended readers of this book are engineers, researchers, and graduate students interested in fuzzy logic control systems.

How to reference

In order to correctly reference this scholarly work, feel free to copy and paste the following:

Luiz H. S. Torres and Leizer Schnitman (2012). Fuzzy Control: An Adaptive Approach Using Fuzzy Estimators and Feedback Linearization, Fuzzy Logic - Controls, Concepts, Theories and Applications, Prof. Elmer Dadios (Ed.), ISBN: 978-953-51-0396-7, InTech, Available from: <http://www.intechopen.com/books/fuzzy-logic-controls-concepts-theories-and-applications/fuzzy-control-an-adaptive-approach-using-fuzzy-estimators-and-feedback-linearization>

INTECH
open science | open minds

InTech Europe

University Campus STeP Ri
Slavka Krautzeka 83/A
51000 Rijeka, Croatia
Phone: +385 (51) 770 447
Fax: +385 (51) 686 166
www.intechopen.com

InTech China

Unit 405, Office Block, Hotel Equatorial Shanghai
No.65, Yan An Road (West), Shanghai, 200040, China
中国上海市延安西路65号上海国际贵都大饭店办公楼405单元
Phone: +86-21-62489820
Fax: +86-21-62489821

© 2012 The Author(s). Licensee IntechOpen. This is an open access article distributed under the terms of the [Creative Commons Attribution 3.0 License](#), which permits unrestricted use, distribution, and reproduction in any medium, provided the original work is properly cited.

IntechOpen

IntechOpen