

We are IntechOpen, the world's leading publisher of Open Access books Built by scientists, for scientists

4,800

Open access books available

122,000

International authors and editors

135M

Downloads

Our authors are among the

154

Countries delivered to

TOP 1%

most cited scientists

12.2%

Contributors from top 500 universities



WEB OF SCIENCE™

Selection of our books indexed in the Book Citation Index
in Web of Science™ Core Collection (BKCI)

Interested in publishing with us?
Contact book.department@intechopen.com

Numbers displayed above are based on latest data collected.
For more information visit www.intechopen.com



Fuzzy Control in Power Electronics Converters for Smart Power Systems

Harold R. Chamorro and Gustavo A. Ramos
*Universidad de los Andes, Bogotá,
Colombia*

1. Introduction

During the last decade, power systems have experienced continuous challenges due to the increasing of demanded energy and the integration with different Renewable Energy Sources (RES) as a possible reduction option to the pollution around the world, for this reason it is necessary the transition to the new power concept known as “Smart Grid”, which has been conceived as the integration of different engineering fields and looks for the application of intelligent controllers with adaptability and interoperability with other systems (Bose, 2010; Momoh, 2009).

Power electronics plays a key role in the interfaces between the Distributed Generation (DG) sources and the power system or users, but it is necessary to add control loops which brings the possibility to give to the power system the flexibility and reconfiguration under disturbances, faults or system requirements (Simoes, 2006; Peng, et al, 2009).

The technology of power electronics converters has evolved dramatically in the last years based on the semiconductors advances, new configuration proposals and important researches in several applications related with the interconnection of Distributed Energy Resources (DER) with the utility grid (Elbuluk & Idris, 2008).

The intelligent control is associated to the emulation of human thought processes and involves some well-known techniques such as expert systems, neural networks and fuzzy logic (Bor-Ren, 1993; Zadeh, 1994; Bose, 2006). The use of these control methods in power electronics has been increased in the last decades, based on its simplicity design, the development of new speed multitasking processors and the necessity to add some controllers which demonstrates robustness in presence of the high nonlinear dynamic characteristics of the power converters.

The primary task of power electronics is the conversion and control of electric power in its two types, Direct Current (DC) and Alternating Current (AC) and its combinations. Fuzzy Logic Control (FLC) has been tested across the whole power converters classification with different objectives. For example in rectifiers, FLC has been used to regulate the output voltage (Cecati et al, 2003 & 2005), in cycloconverters, with the purpose to improve the power quality and regulate the load voltage (Sivakumar & Jickson, 2011). In DC-DC converters, FLC has been applied to the regulation of load voltage in different operation

conditions (Bor-Ren, 1993; Mattavelli et al, 1997) or Power Factor Correction (PFC) taking into account the application (Kolokolov, 2004).

In resonant converters and soft self - switching power circuits, the use of FLC has shown significant contributions obtaining the expected results, that with other techniques might not be obtained with the same simplicity design (Corcau & et al, 2010; Chamorro & Trujillo, 2009).

Moreover, FLC has been applied in inverters, specially in Voltage Source Converters (VSC) assuring phase and voltage magnitude (Ayob & et al, 2006) in the power flow control with the utility grid in different operative regions (Diaz & et al, 2007; Chamorro & et al, 2009).

There are plenty of developments of FLC in power electronics in all the voltage scales and power sectors. In Photo Voltaic (PV) applications, FLC has been proposed to optimize the Maximum Power Point (MPP) with outstanding results compared with other methods (Alajmi et al, 2010; Chaouachi et al, 2010; Shireen et al, 2011).

Another important application has been developed in High Voltage Direct Current (HVDC) in both stations (rectifier and inverter) ensuring an adequate performance despite of the system complexity (Liang, 2009).

In the industrial sector as well, FLC has demonstrated a satisfactory use in Adjustable Speed Drivers (ASD) for three phase induction motors under mechanical loads with good results (Chamorro et al, 2009; Chamorro & Toro, 2010).

One important advantage which offers the FLC is the possibility to use it as a hierarchical layer with the ability to supervise and to coordinate other systems such as electric vehicles (Ferreira et al, 2008), Flexible AC Transmission Systems (FACTS) (Sadeghzadeh & Ansarian, 2006) or even Microgrids (MG) and its interaction with power electronic interfaces (Papadimitriou & Vovos, 2010; Chamorro & Ramos, 2011) which is the main point in this chapter.

A basic conceptual representation of a MG is presented in Fig. 1, where it is depicted the physical layer and involves a high penetration of DG (photovoltaic, fuel cell, fly-wheel storage, micro wind turbine) with power electronic interfaces. The MG is connected to the utility distribution system through a static switch and a transformer.

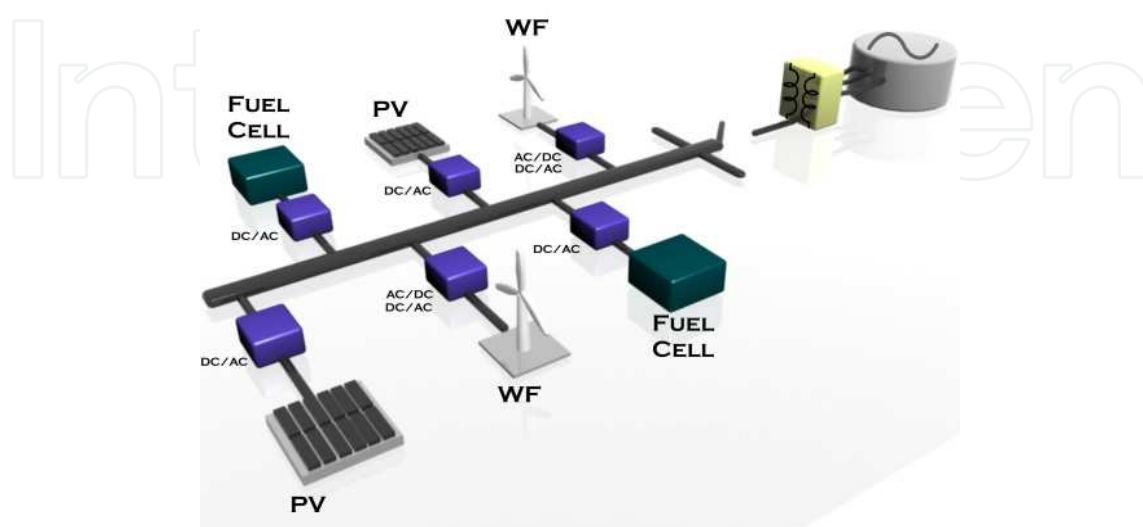

Fig. 1. Microgrid Structure Concept

This chapter gathers together some previous works related with the application of fuzzy logic control in power converters and explain its use in Smart MG. The developments presented in this chapter start from theoretical and mathematical background and are supported in literature and recent contributions in the field exposed. For the rest of this chapter the use of FLC is shown in different power converters as follows: In section II it is presented the application of a FLC in a soft switching converter. In section III it is explained two applications of FLC for a VSC. In section IV it is shown two innovative proposals for MG applying FLC as supervisory/hierarchical control. Finally the obtained conclusions are presented.

2. Takagi Sugeno approach control for a resonant DC link converter

With the advent of the deep penetration of renewable energy sources along the power system, the application of new power electronic techniques are becoming a necessity in order to improve the efficiency and to get the maximum power transfer as long as possible.

Soft switching topologies and resonant power converters are well known by offering a significant reduction in the switching losses and the components size involved, the decreasing of the thermal requirements, and operating at high frequencies (Rashid, 2001).

During the last decades, some important developments have shown the applicability of the soft switching circuits in PV arrays and the interfaces in their power conversion chains as a mean of raising the switch power ratings in the inverters associated (Bellini & et al, 2010; Kasa & et al, 2005).

One of those soft switching topologies is the resonant DC link circuits which are the interfaces between DC power supplies or PV cells and the inverters as it can be seen in Fig. 2. These circuits consist of a front - ended converter to cause the DC link voltage to generate a periodic Zero Voltage Switching (ZVS) condition in which the inverter switches can be turned on or off. However, these kinds of converters require defining previously a timing program for each switch in order to obtain the expected modes and their resonance.

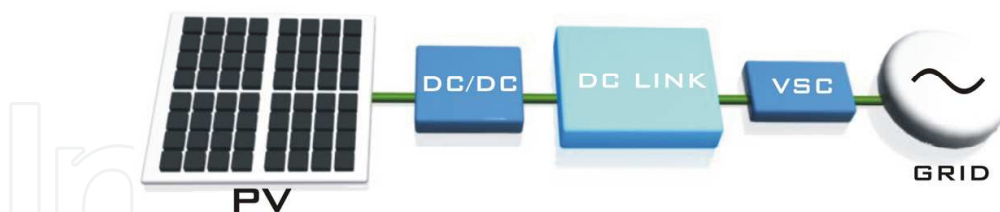

Fig. 2. DC Link Interface

Fuzzy Logic Control (FLC) has been applied in different soft switched inverters in order to provide a standalone way of switching with good results (Shireen & et al, 1996). In a previous work it is demonstrated the applicability of the FLC in a DC link circuit interacting with a VSC (Chamorro & Trujillo, 2009), now it is presented the TS approach, its design and some relevant tests.

2.1 DC link circuit under study

The DC link circuit scheme can be seen in Fig. 3, where is highlighted the tank circuit composed by a L_r inductor and a C_r capacitor and three controllable switches and diodes. It

is assumed that a high inductive load represents the inverter as a I_o current source. The states and detail considerations can be seen in (Shireen & et al, 1994).

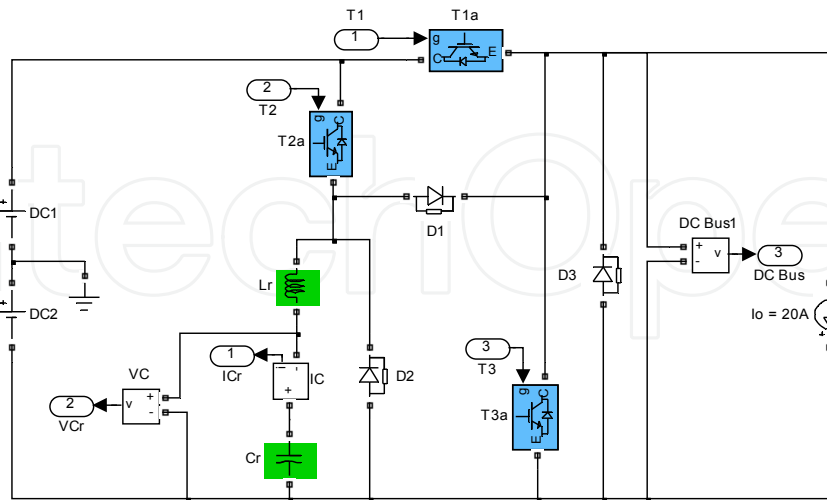

Fig. 3. DC Link Circuit

2.2 Takagi Sugeno design

This approach takes advantage of a previous development originally proposed in (Shireen & et al 1996), where is presented a FLC with the objective to pulsate to zero the DC link, allowing soft switching in an inverter connected and to reduce its switching losses as it is demonstrated in a recent paper (Chamorro & Trujillo, 2009).

The design starting point is the definition and classification of sets according to the voltage and current measurement signals in the capacitor. The definitions of linguistic variables are based on a previous developed knowledge evaluation of the current and voltage waveforms in open loop. These waveforms are presented in Fig. 4

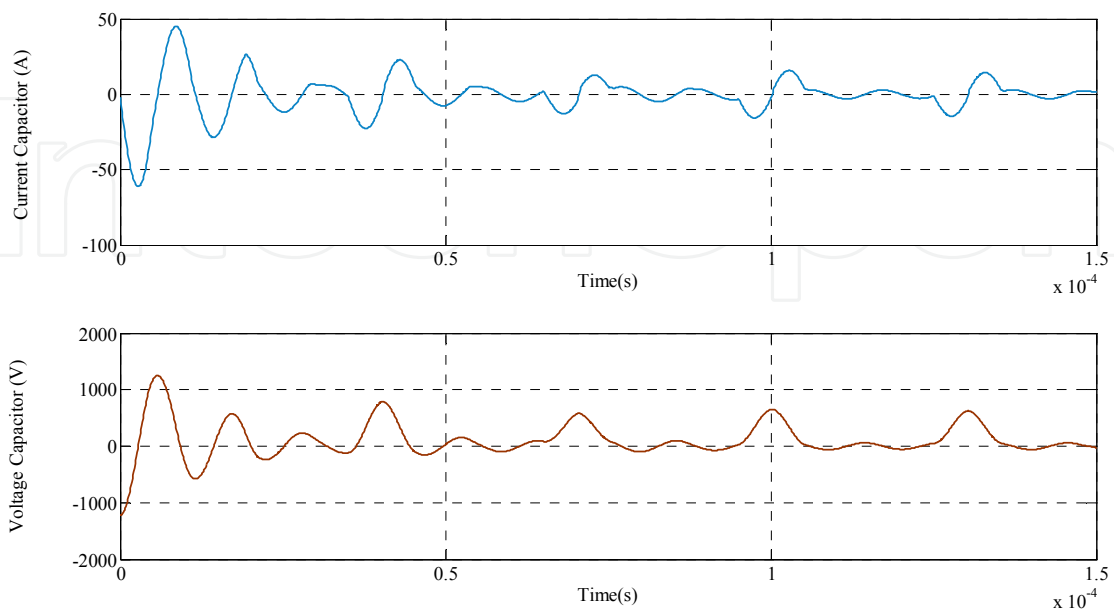

Fig. 4. Current and Voltage Capacitor Waveforms

Some special attention is required, in order to establish the specific boundaries of the regions in each subset, specifically the zero region and the high positive and negative levels, which imply some important details in a real hardware application such as the rated values of the capacitor and inductor and their time response under a fast variability.

According to the waveforms obtained, on the antecedent the input membership functions are conformed as it can be seen in Fig. 5 , where the linguistic labels mean Negative (N), Zero (Z), Positive Small (PS), Positive Large (PL).

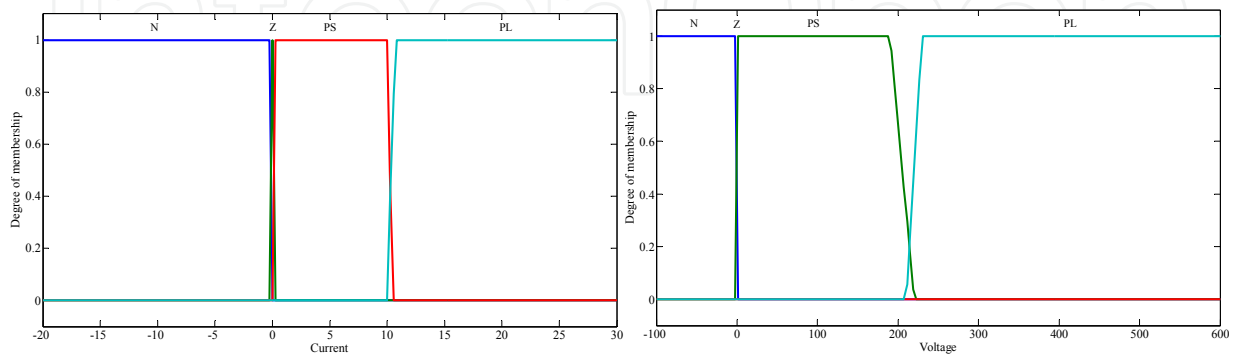

Fig. 5. Input Membership Functions

The Takagi – Sugeno system is employed as inference method, using constants or zero order Sugeno models in the output membership function, which represents the turning off or on action of the switches in the DC link circuit. The positive constants are interpreted as the turning on of the switches and the negative constants like the switches turning off instead, for example to turn on the switch called T_1 the constant associated is 5, or to turn off the switch T_2 the correspondent constant is -10. In order to present these mentioned changes, a graphic of the rule viewer of FIS toolbox of Matlab® are shown displaying the fuzzy inference. The three small plots across the top of the Fig. 6 represent the antecedent and consequent of the rules.

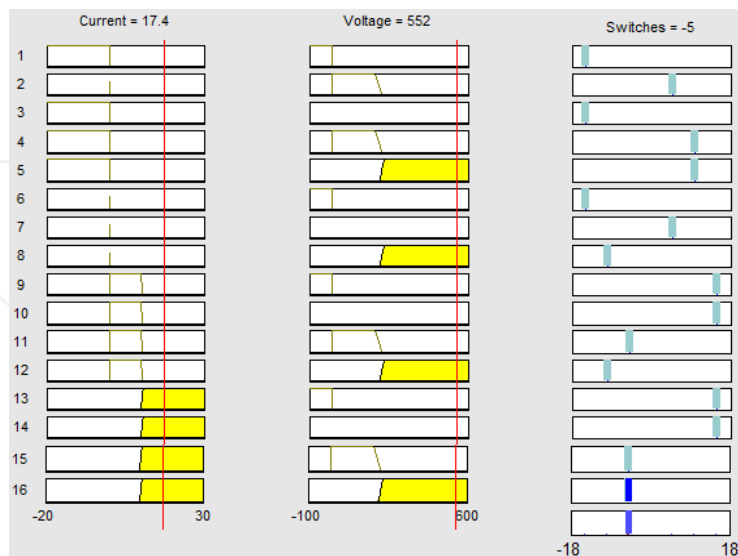

Fig. 6. RuleViewer

The complete rule base determines all the decisions of the switch turning on or off. The decision table is presented next.

v_c/i_c	N	Z	PS	PL
N	NL	NL	PM	PM
Z	NL	PS	PS	NM
PS	PL	PL	NS	NM
PL	PL	PL	NS	NS

Table 1. Decision Table

The surface control associated it is presented in Fig. 7

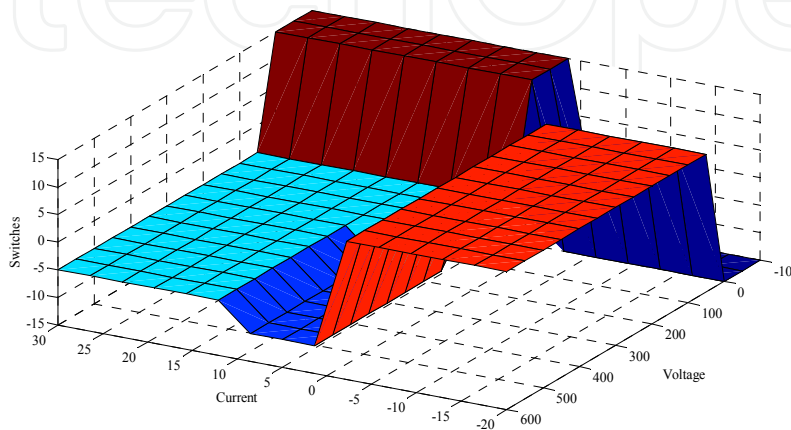

Fig. 7. Surface Control

The final step of the FLC design is the defuzzification process, in this case it is used the common weight average method.

2.3 Simulation results

The proposed structure of the fuzzy soft switching control is presented in the next Simulink[®] block diagram, where it is shown the DC link with its two outputs as the current and voltage measurements, the FLC embedded and the switching pulses generator.

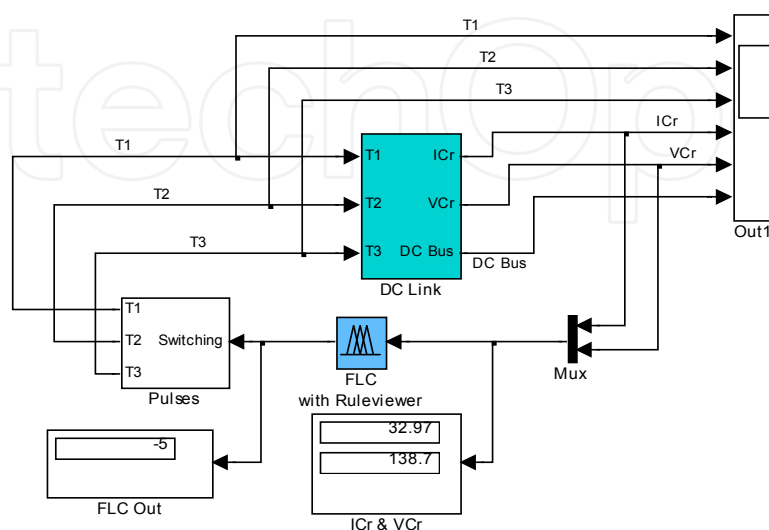

Fig. 8. Closed Loop System

The simulation tests in closed loop with the T-S FLC shows an adequate performance and a similarity with the voltage and current waveforms and the soft switching response, as it can be seen in Fig 9.

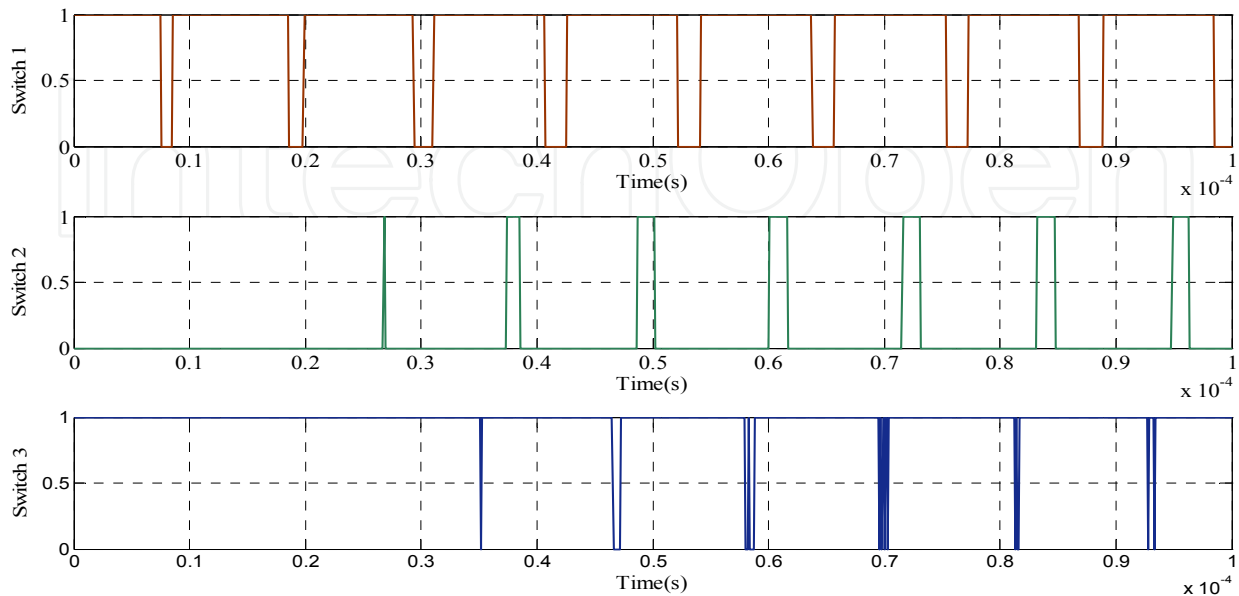

Fig. 9. Self-Switching Pulses

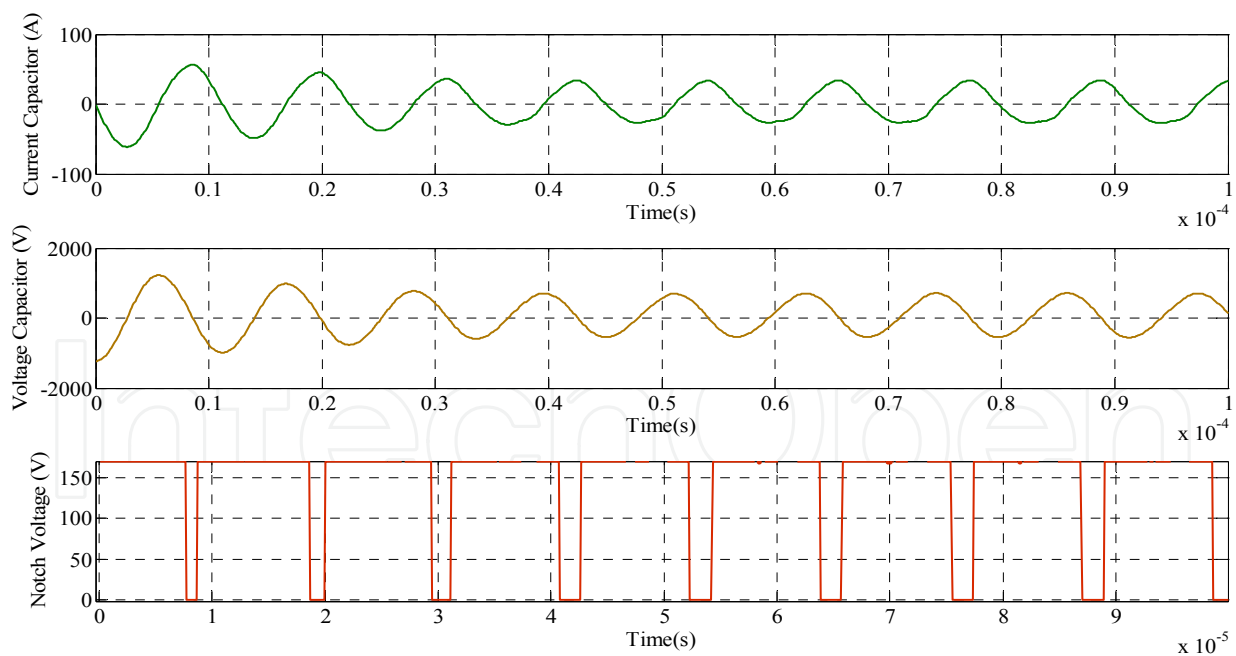

Fig. 10. Obtained Waveforms with FLC

In order to show the adaptability and performance of the DC link circuit and the FLC, another test is done with a current source variation with high and abrupt changes. As it is shown in Fig. 11 the FLC is adaptable even under those several changes and the waveforms conserve their resonant behaviour without instability or not desired transient signals.

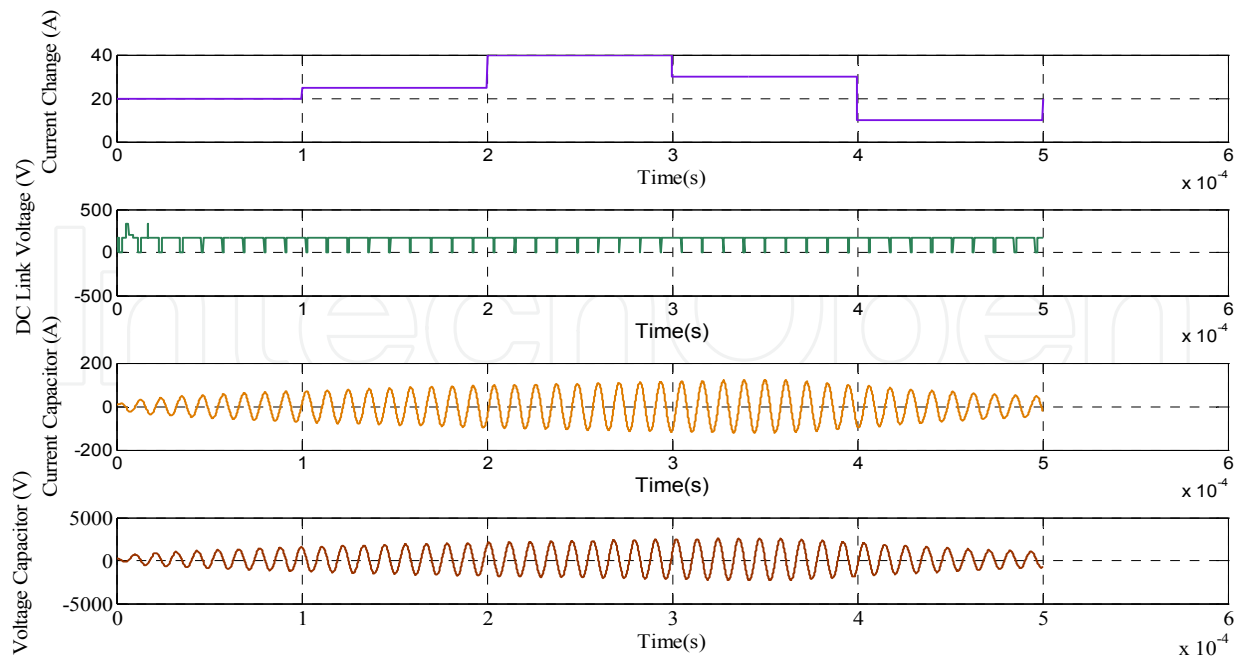

Fig. 11. Current Variability

3. Fuzzy applications in VSC

One of the most significant converters which have played and will play an important role in the power networks, industry and traction systems is the Voltage Source Converter (VSC). This converter has been applied in different applications such as High Voltage Direct Current (HVDC) power transmission, Adjustable Speed Drivers (ASD), Active Power Filters (APF), Uninterruptible Power Supplies (UPS), electric vehicle drives and the connection of RES, mainly with, wind farms and Photo Voltaic (PV) arrays to grid.

Voltage Source Converter (VSC), used in Supergrids (SG) and MG, are able to manage the bidirectional power flow with the grid (Diaz & et al, 2007 & 2008) and other MG through the tie lines involved (Chamorro & Ramos, 2011).

On the other hand, most industries around the world use three phase induction motors due their high durability, low maintenance and cost, however, it is necessary to add an extra controller with the purpose of achieving speed regulation under mechanical loads, hence, the VSC has become an important piece in the industrial processes given its versatility as an ASD (Mokrytzki, 1991).

This section presents two applications using fuzzy logic in their control loops demonstrating the easiness of design and its importance in the smart electrical systems.

3.1 Voltage source converter operation

Fig. 12 depicts the main components of a VSC, where it can be seen a three phase fully controllable of six semiconductors, typically Insulated Gate Bipolar Transistors (IGBT), a DC capacitor on the DC side in order to provide constant DC bus voltage with a minimal ripple.

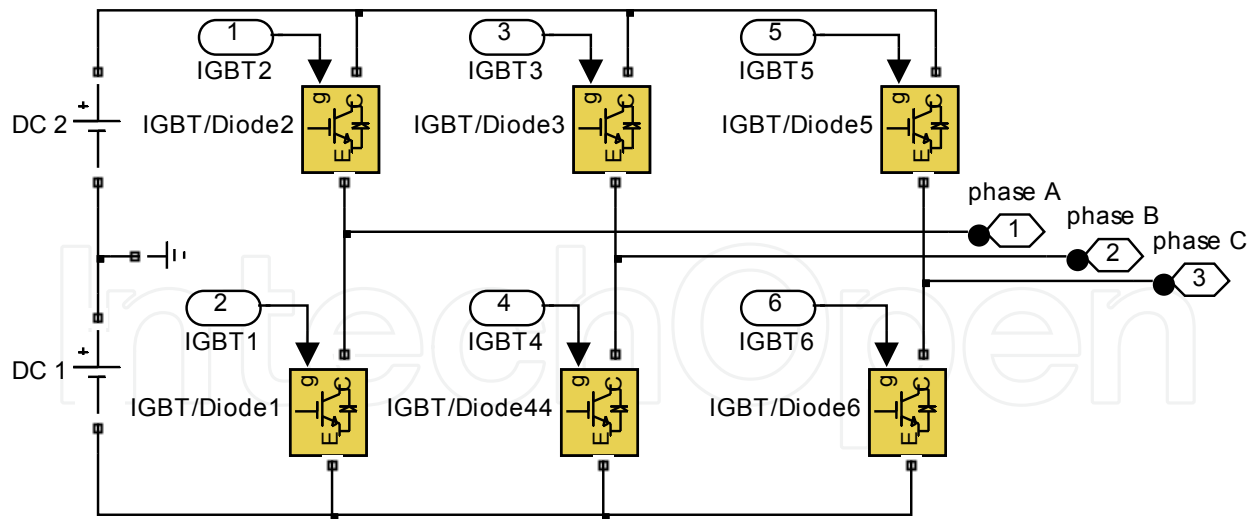

Fig. 12. Voltage Source Converter

One of the simple switching techniques applied to VSC is the conventional method known as Sinusoidal Pulse Width Modulation (SPWM), this method is used to manipulate and control the VSC in both of the cases mentioned above.

3.2 Three phase induction motor speed control

Rotating electrical machines, specifically three phase induction motors are the functional units with more electricity consumption in the industry, due to their widely use in manifold applications as diverse as industrial fans, blowers and pumps and machine tools, keeping in mind its advantages like resistance, easy maintenance, low cost and durability (Xiaodong & Ilochonwu, 2011).

Different techniques and improvements have been used to regulate the speed in induction motors such as sliding control (Chung-Yuen & et al, 1992), scalar control (Bose, 1984), vector control (Matsugae & et al, 1990) or direct torque control (Takahashi & Ohmori, 1989) with notable results, nevertheless these methods require the system model or use indirect measurements in the closed feedback loop control.

With the new developments in power electronics devices and microprocessors, the design and implementation of power converter control circuits based IA it has been made possible and easier than in the past.

In this section it is presented the application of a FLC in order to regulate the speed in a three phase induction motor with the VSC as actuator as it is highlighted in Fig. 13.

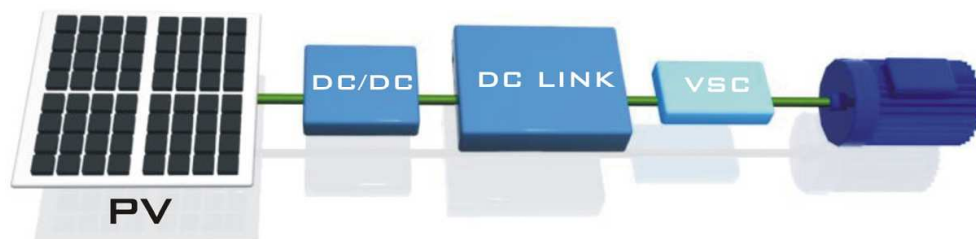

Fig. 13. Voltage Source Converter Interface

3.2.1 Induction motor operation in open loop

The induction motors have high nonlinear characteristics and a mathematical complex model associated (Carmona & et al, 2010). Although these electrical machines are quite efficient, they require of a speed regulation algorithm under mechanical loads as it is shown in Fig. 14. The speed rate (1400rpm) is not regulated and is changing insofar as the mechanical load is increased or decreased.

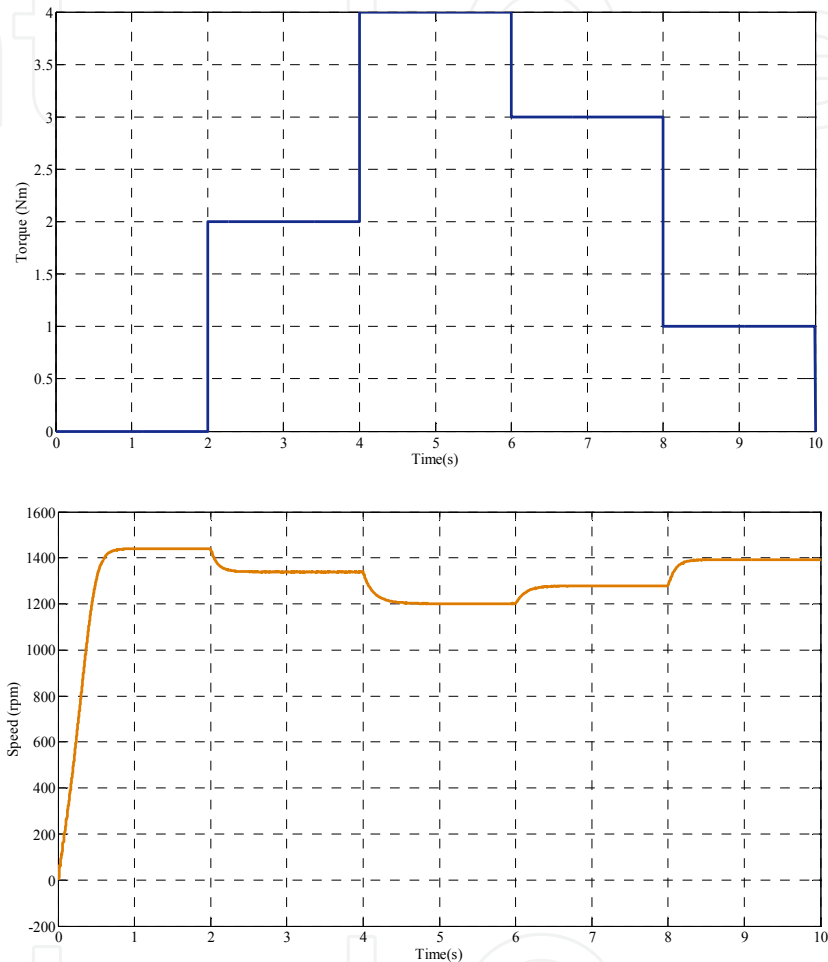

Fig. 14. Speed time response of the induction motor studied in open loop

The three phase voltages are provided by the VSC depending on the SPWM signals and their variation.

Any change in the SPWM signals is reflected in speed changes in the induction motor through the VSC action, hence the frequency and amplitude modulation index are selected to achieve this action properly. The first is the frequency modulation index (m_f), which is the relation between the carrier frequency or triangular signal and the frequency control signal or sinusoidal signal, the latter (m_a) is the amplitude relation of those signals and are expressed as:

$$m_f = \frac{f_{carrier}}{f_{moduler}} \quad (1)$$

$$m_a = \frac{a_{carrier}}{a_{reference}} \tag{2}$$

A basic scheme of an individual (VSC-Motor) unit it is shown in Fig. 15, where is highlighted the SPWM generation signals block and the main components involved.

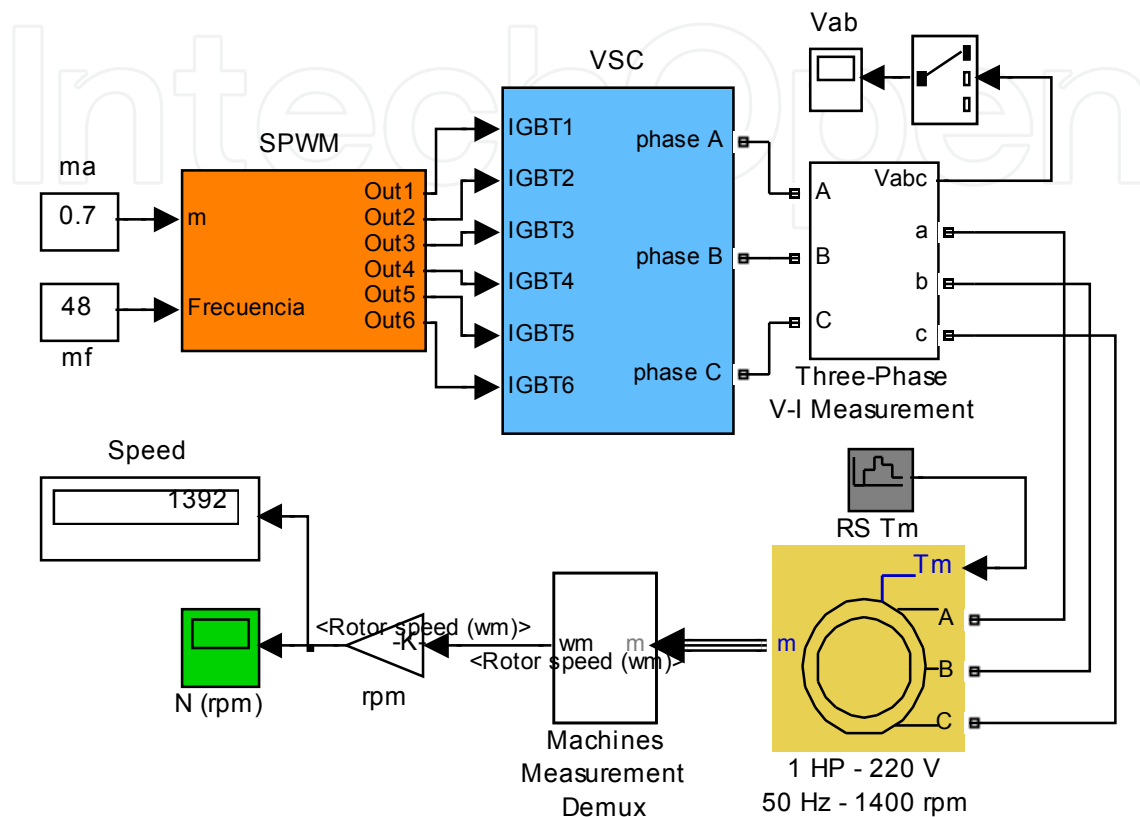

Fig. 15. Open Loop System

3.2.2 Proportional derivative fuzzy speed control

According to the behaviour shown above, it is designed a FLC speed regulation control. FLC design begins from a previous knowledge of the induction motor speed variations where the modulation index (Δm) and frequency (Δf) are changed in the SPWM signals in the VSC, so that the motor model is not required, however it is necessary to keep in mind the rated values of power, torque or speed as limits or condition constraints in the control action, the power and speed are related by the following expression:

$$P = \tau \omega \tag{3}$$

The control designer should know the speed variability when it is applied a mechanical load and the rated values such as the nominal speed, torque and the rotor and stator resistance and reactance respectively only.

FLC strategy can be developed based on classical architectures design conserving its series or parallel topologies. It is common to use the error as an input as well as the error deviation (PD) or the integral error (PI) even with fuzzy controllers.

When is implemented a FLC, particularly a PD fuzzy control, it is difficult to specify the gain controller effect in the rise time, overshoot and settling time, where the non-linearities are more frequent, therefore it is necessary to determine an adequate tuning procedure of the controller to obtain an optimal and adaptable response.

PD fuzzy control is selected over other fuzzy control types based on its inherent advantages facing significant disturbances and has been implemented with great success in different power converters (Chamorro & Toro, 2010).

Membership functions are determined by the control designer, taking into account that a large number of functions result in a large rule basis per input. Otherwise a reduced number of functions could introduce a non-operative or undesired operation point.

As it is mentioned above, the inputs are the speed error and the speed error deviation. In Fig. 16 it can be seen these membership functions respectively.

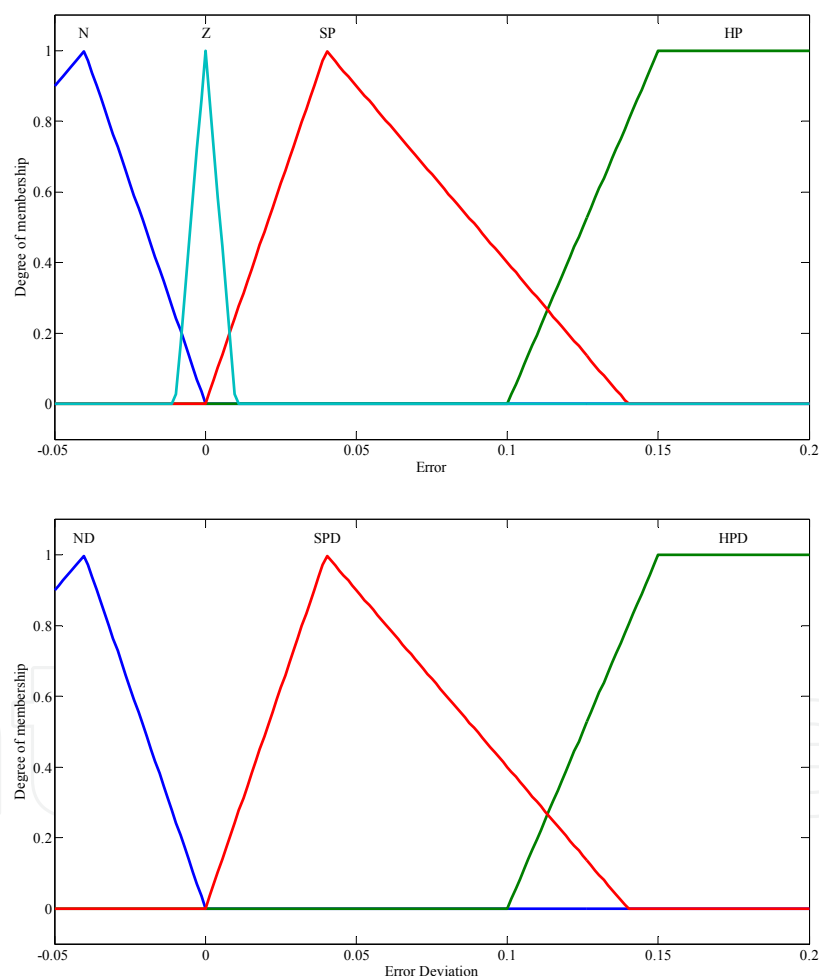

Fig. 16. Antecedent Membership Functions

Speed error is calculated with comparison between reference speed and speed signal feedback. It is established four overlapping fuzzy subsets for speed error, three for speed error deviation and seven for each output. The linguistic labels chosen are: Negative (N), Zero (Z), Small Positive (SP), High Positive (HP), Negative Deviation (ND), Small Positive

Deviation (SPD), High Positive Deviation (HPD), High Decrease (HD), Medium Decrease (MD), Low Decrease (LD), Not change (NC), Low Increase (LI), Medium Increase (MI), High Increase (HI).

The controller outputs are the modulation index deviation (Δm_a) and frequency index deviation (Δm_f) where the membership outputs have the same fuzzy subsets as it can be seen in Table 2 and in Fig. 17 is presented these functions.

Error	Error Deviation	$\Delta m, \Delta f$
HP	BPD	HD
SP	SPD	MD
Z		LD
N	ND	NC
		LI
		MI
		HI

Table 2. Antecedent and Consequent Variables

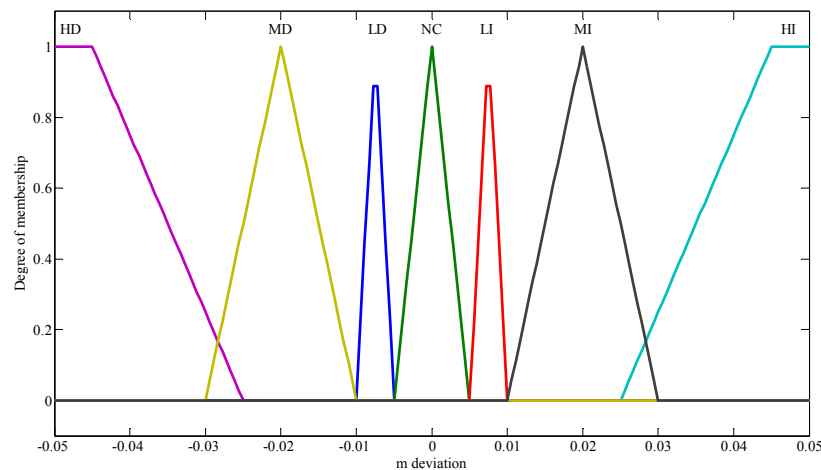

Fig. 17. Consequent Membership Functions

Speed error and speed error deviation are normalised in order to fit out and process adequately the input systems. It is needed an scale factor according to the induction motor rated speed, in this case 1400 rpm, with the aim to guarantee a proper variability.

The fuzzy rules basis is shown in Table 3 with a combinatory option of 12 (3x4) rules:

$\Delta e/e$	N	PN	Z	SP
ND	HD	MD	LD	LD
BPD	LD	LI	LI	MI
SPD	NC	NC	NC	LI

Table 3. Decision Table

The defuzzifier selected is the average of centres as is expressed in (4):

$$y^* = \frac{\sum_{n=1}^M y_n w_n}{\sum_{n=1}^M w_n} \quad (4)$$

Where M is the number of fuzzy sets, w are the weights of set defined for its height and y^{-1} is the centre of n -esimal fuzzy set.

The control surface associated is shown in Fig. 18.

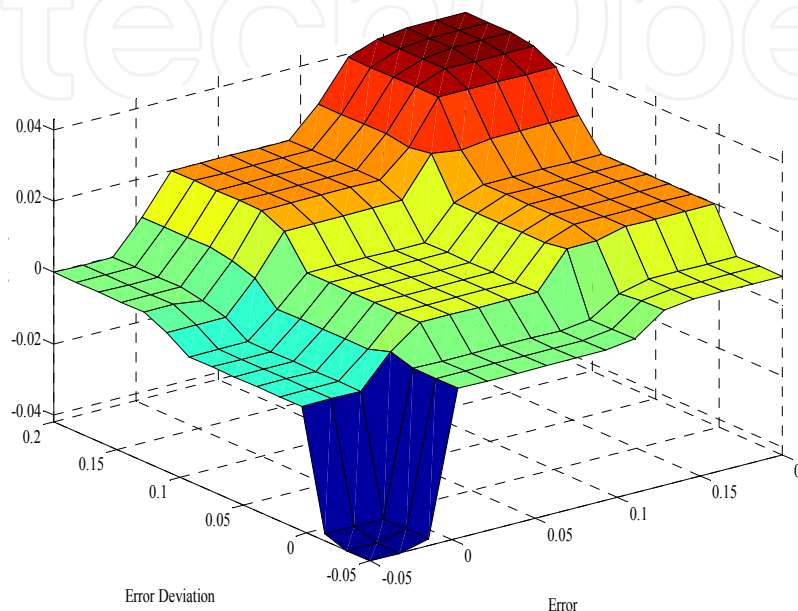
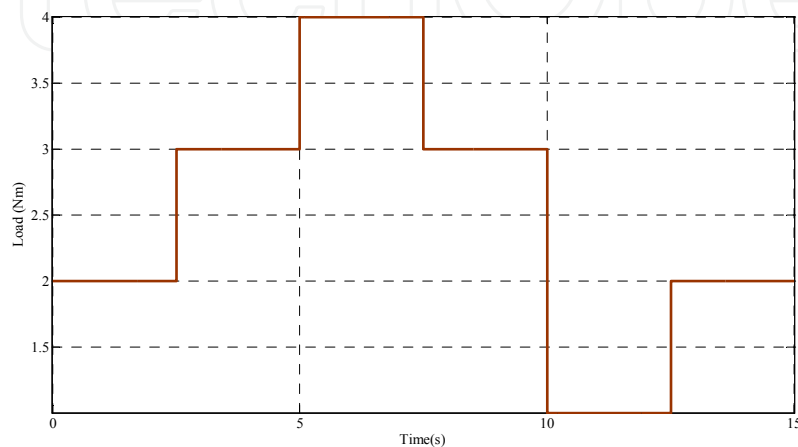

Fig. 18. Control Surface

A detailed design can be seen in previous works (Chamorro & et al, 2009; Chamorro & Toro, 2010), where is exposed the overall performance and the dynamic prefilters used.

3.2.3 Simulation results

With the rules explained above, a variability load is evaluated to confirm the performance of the controller proposed, the control action achieves the rated speed regulation even with an abrupt load decrease as it can be seen in Fig. 19.



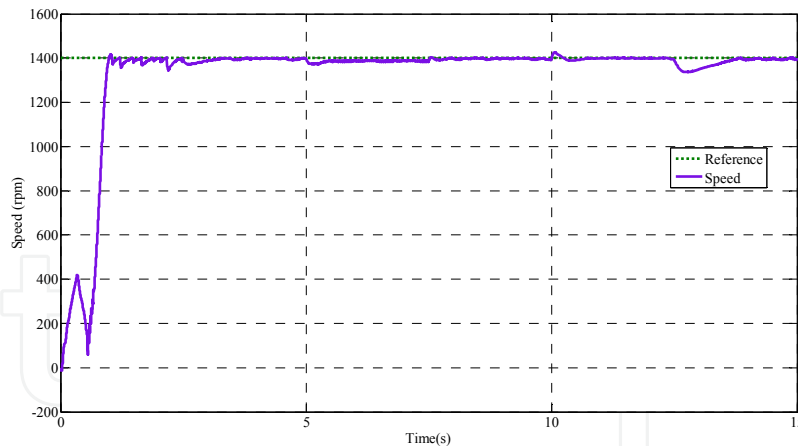

Fig. 19. Speed time response with speed regulation under mechanical load variability

3.3 Power flow control

VSC used as the interface between Renewable Energy Sources (RES) with the utility grid or autonomous systems, has demonstrated the power transfer capability from MG with excess generation to those with power demands. A representation of this application can be seen in Fig. 20.

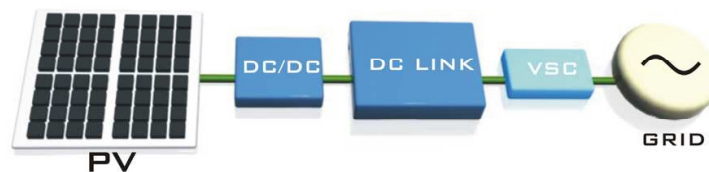

Fig. 20. VSC Interface

The active and reactive power exchange is possible with the manipulation of the SPWM signals via a small reactor (Guangkai & et al, 2006).

The principle of operation of VSC is subjected to the management of phase shift and modulation index variability signals generated by SPWM. The active and reactive power exchange between the VSC and the AC network or another VSC is expressed as follows in (5) and (6).

$$P = \frac{U_s U_c}{X} \sin \delta \tag{5}$$

$$Q = \frac{U_s (-U_s + U_c \cos \delta)}{X} \tag{6}$$

where,

P : active power

Q : reactive power

U_c : VSC voltage

U_s : bus voltage

δ : phase difference with the voltages

X : coupling reactance reactor

According to these equations, it should be possible a fully control of the active power by δ and the reactive power by U_c deviations respectively (Singh & et al, 2006) and independently (Liu & et al, 2009). The power flow concept is depicted in Fig. 21.

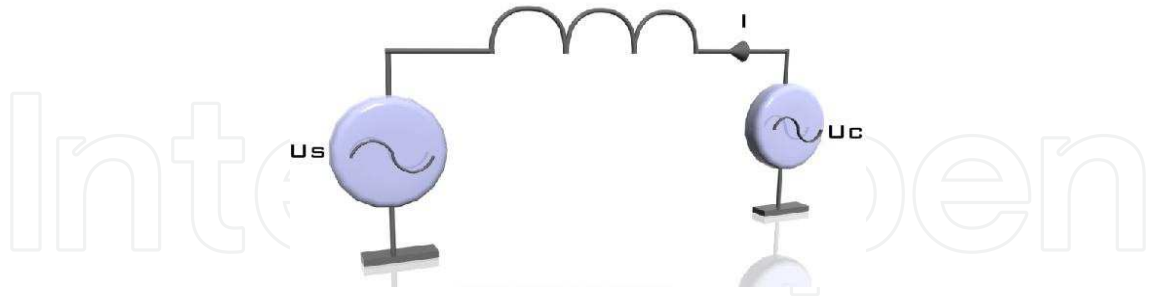

Fig. 21. Power flow equivalent circuit

Fig. 22 represents the four operation regions involved in the MG, which corresponds to the combinations of power imported or exported (Forero & et al, 2009). High non – linearity is experienced when both power references are changed abruptly and the control strategy must adapt to and stabilise the system in order to prevent a critical fault or important damage in any hardware device.

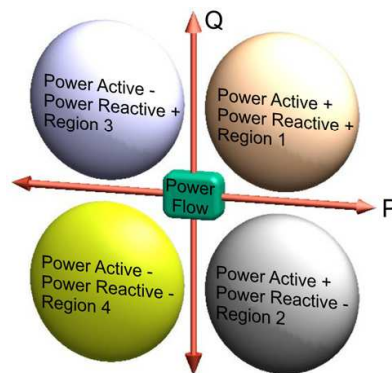

Fig. 22. Division of VSC HVDC Power flow operation zones

A basic MG that consists in one DER, a VSC unit and a low pass LC filter is shown in Fig. 23. A local Fuzzy Logic Control (FLC) which is in charge of the power flow regulation is added too.

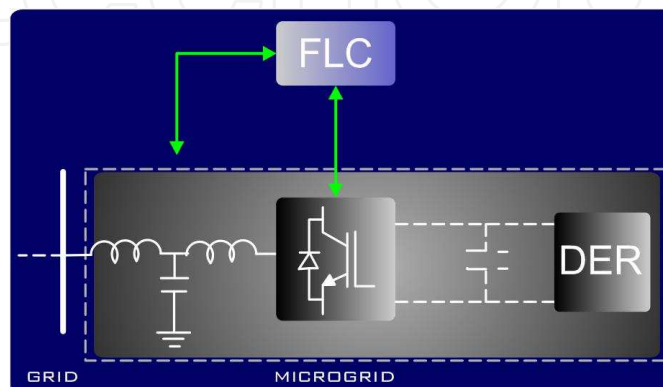

Fig. 23. MG block representation with Fuzzy Logic Controller

3.3.1 Fuzzy logic control VSC-GRID

Fuzzification: in this first step, the crisp inputs are transformed into fuzzy inputs. According to the inputs, error (e) and error deviation (de), the membership functions are assigned.

The output signals are modulation index (m) and shift phase (φ), the variability of these signals implies some changes directly in SWPM, allowing control of the power flow.

The membership functions have five different values to achieve good power reference tracking, big=B, low=L, zero=Z, negative=N, positive=P, change=C, medium=M, decreasing=D and increasing=I respectively. The letter concatenation represents a variable and each variable represents a membership function.

The normalisation signals are achieved with some constants in order to get a specific value with the required accuracy, as it is explained below in detail, and then the crisp data is converted into fuzzy sets to be compatible with the fuzzy set representation, by means of a fuzzifier, which in this case the Mandani implication is used:

$$\phi[\mu_A(x), \mu_A(y)] = \mu_A(x) \wedge \mu_q(y) \tag{7}$$

Fig. 24 shows the input and output membership functions and the rule basis where the overall combination for Fuzzy Control of active Power (FCP) and Fuzzy Control of reactive Power (FCQ) can be inferred.



Fig. 24. Membership functions and look - up table

The second step is the fuzzy inference process, in this, the membership functions are combined with the control rules. A possible rule evidenced in this system could be: If the value of error is small but conserves its rate, the SPWM signal requires an increment in the magnitude and angle rigorously.

The linguistic labels are formulated according to the power operation regions and the error and error deviation measurements and limits bordered by the frame system.

In the final step, it is necessary to quantify to get a numerical value, the method of defuzzification used in this section is the Center of gravity (CoG), based on its fast computation and its wide use (Bai & et al, 2006).

3.3.2 Results grid – Connected mode of operation

Fig. 25 shows the MG - VSC - Grid system implemented in Simpower[®]. The green and grey blocks are the (p) and (q) decoupled fuzzy local controllers respectively.

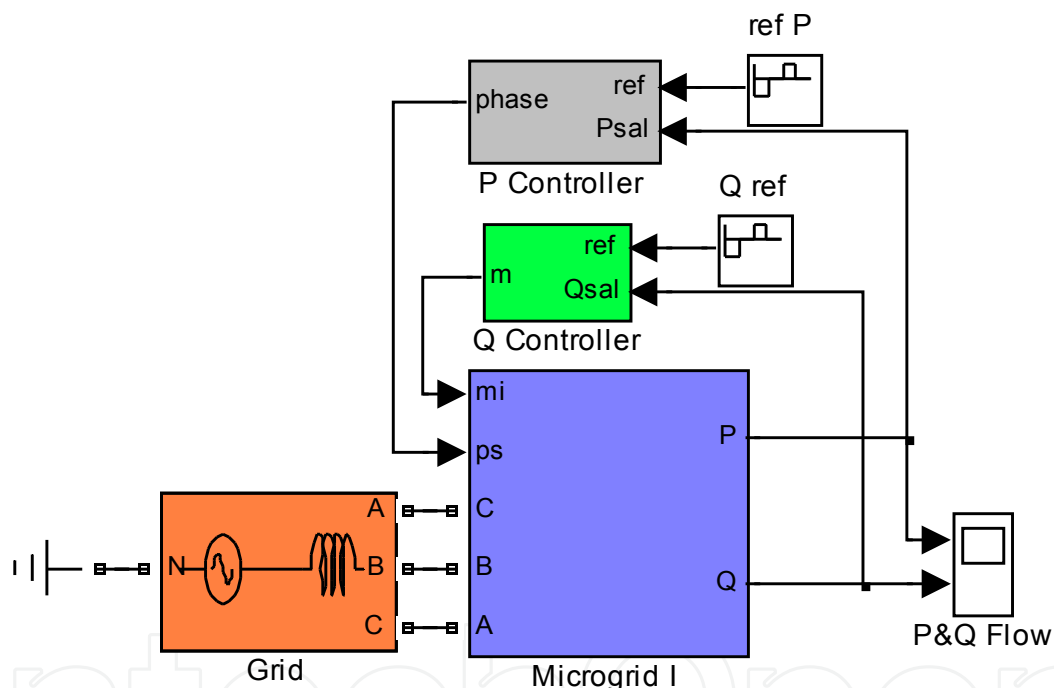

Fig. 25. Block system of three phase grid connected VSC

The time response of the power flow controller is presented in Fig. 26, as it can be seen, the fuzzy control tracks the reference. An important observation is that each reference is generated only when the previous power reference has been reached.

4. Fuzzy hierarchical/supervisory control

The future power networks will require of innovative alternatives and algorithms that can provide some kind of smartness to achieve an effective coordination, self-healing and diagnose and autonomous operation and automation. In this section, the use of fuzzy hierarchical or supervisory frameworks in these systems is considered and it is proposed two applications related.

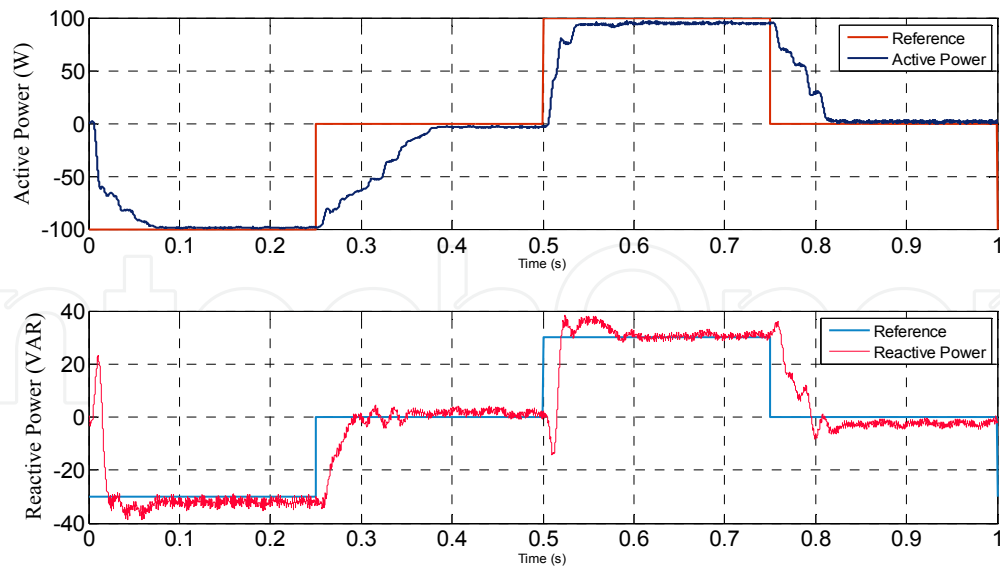

Fig. 26. Active and reactive power controller time response

4.1 Induction motor coordination in industrial environments

The combination of RES and power electronics interfaces in MG requires different control strategies and diverse control layers to obtain multiple objectives and an adequate response avoiding voltage unbalances and power quality disturbances (Lasseter, 2001; Binduhewa & et al, 2008).

Some of the advantages to implement DC MG in industrial environment systems are the reduction of transmission and distribution losses and ensuring power quality in loads. Another advantage of MG is the versatility of connection related with their two operation modes: in grid connected mode, the power supply is shared with the main grid and, in island mode the local RES supply the load system autonomously (Ding et al, 2010).

This approach is oriented to the induction motors coordination in industry, under a fuzzy supervisory frame where there are imprecise and vagueness data, causing loss of synchronism or changes in the different set points.

Fig. 27 depicts a DC MG where are some RES and induction motors. There is a lower control layer that determines the local speed set points and an upper (supervisory) layer that coordinates the whole speed references and synchronise the speed at one if it is necessary.

The upper layer control has a fuzzy structure based on the industrial system knowledge base where it has been experienced several damages and important extra costs associated. In this study is taken as example one type of industry, where has been applied or required the use of induction motors.

The type of industry is concerned with the necessity of the synchronisation of different induction motors at one speed reference like in textile industries, where the speed unification is an important consideration because of a minimal disturbance can cause an unexpected standstill; besides is necessary to consider the fact that not all the motors have the same mechanical load.

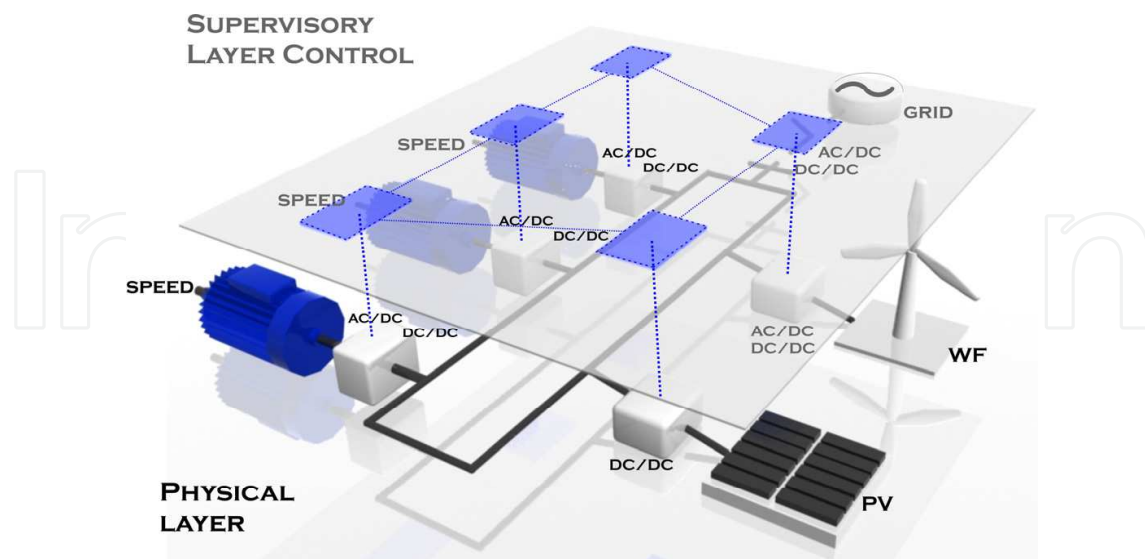

Fig. 27. Supervisory Control in Industrial DC Microgrids

In the study reported in this section are considered conditionals and priority statements to form the decision making actions.

The fuzzy supervisory control specifies the next actions listed as follows:

The first priority is to regulate the speed steady state error in each unit (VSC - Motor) according to the speed set point desired and the operation range involved. This could be expressed like a fuzzy rule as:

if the speed set point is changed in each unit n , then change the m_a and m_f applying the fuzzy local control rules explained above.

The speed error and speed error deviation are given by:

$$e_s = P_o - P_s \quad (8)$$

$$\Delta e_s = e(k) - e(k-1) \quad (9)$$

where,

P_o is the speed measured

P_s is the speed required

4.1.1 Simulation results

A desynchronization time is previously defined in order to test the supervisory control layer. In Fig. 27 it is shown the speed response of four units (VSC - three phase induction motors) while it is acting a constant mechanical load of 3 Nm. As it can be seen, immediately the supervisory control starts to apply the weights and two seconds later all the machines reach the rated speed at the same time, it is necessary to do a zoom in the simulation window to see the action mentioned, this effect is shown in Fig. 28 too.

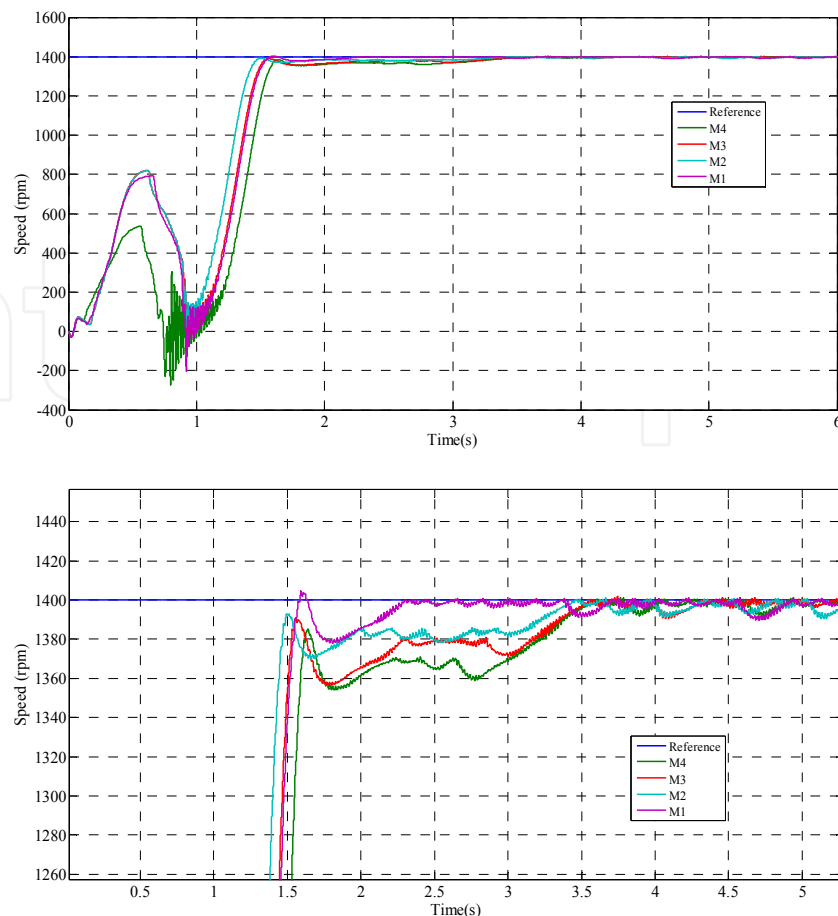

Fig. 28. Supervisory Synchronisation Control Induction Motors in the DC MG and Window Time Zoom In.

4.2 Microgrids power flow hierarchical control

The intentional islanding in MG refers to the condition where it is isolated from the utility grid and operates by itself (Balaguer, 2011), in this situation it is important a hierarchical central control layer to provide power management between the microsources and their loads.

With the integration of a central control in multi – energy generator systems, it is possible to control and to drive the energy to a MG side via the VSC operation. The central control main functions are the synchronization of VSCs in order not to exceed the nominal power limits, to avoid the power flow cancellation and coordinate and decide which VSC is in operation or not, at the same time, for this reason the FLC is chosen as a control method. In Fig. 29 is depicted the overview of the power flow in MG.

The fuzzy control levels specify three actions listed as follows:

1. The decision of power importation and exportation according to the necessity and the coordination of the VSC which is in operation. This could be expressed as a fuzzy rule as:
 - if the active and reactive power is required in MG k , then export them from other MG.

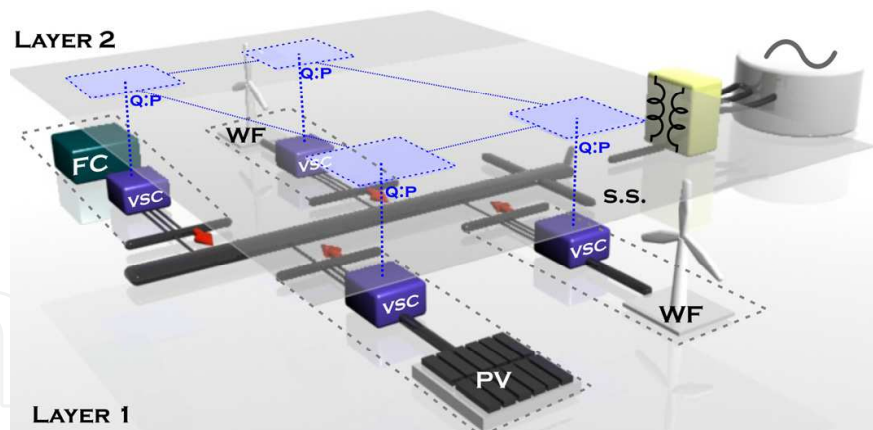

Fig. 29. Hierarchical Fuzzy Control

The power flow control in function of this control architecture following the equations (10) and (11) can be mathematically expressed as:

$$P_{ir} = \frac{U_i U_r}{X} \sin \delta \quad (10)$$

$$Q_{ir} = \frac{U_i (-U_i + U_r \cos \delta)}{X} \quad (11)$$

where,

r = is the VSC unit which requires power,

i = is the VSC unit which exports power,

with,

$$r = 1, 2, \dots, n \quad (12)$$

$$i = 1, 2, \dots, n \quad (13)$$

N : number of VSC units

and $i \neq r$

1. The power share between VSCs or as a fuzzy rule function:
 - if a MG k is enabled or disabled, then disable or enable the sum or power in the bus.

$$P_{sum} = \sum_{i=1}^N P_i \quad (14)$$

$$Q_{sum} = \sum_{i=1}^N Q_i \quad (15)$$

1. The regulation of steady - state power error: an important aspect proposed, is the requirement in the coordination of the power reference changes when a MG requires it and involves the primary control level explained above. Based on this desired behaviour, the corresponding fuzzy rule is:

- if the power set point is changed in MG n , then change the power setpoints in the other MG and apply the fuzzy local control rules.

The error and error deviation are given by:

$$e_p = P_o - P_s \tag{16}$$

$$e_q = Q_o - Q_s \tag{17}$$

$$\Delta e_p = e(k) - e(k-1) \quad \wedge \quad \Delta e_q = e(k) - e(k-1) \tag{18}$$

where,

P_o, Q_o are the powers measured

P_s, Q_s are the powers references

The system presented in Fig. 30 shows the power flow control between four VSCs, in this case, one of them requires power (in orange), the fuzzy central control decides to disable one MG and to enable the other two.

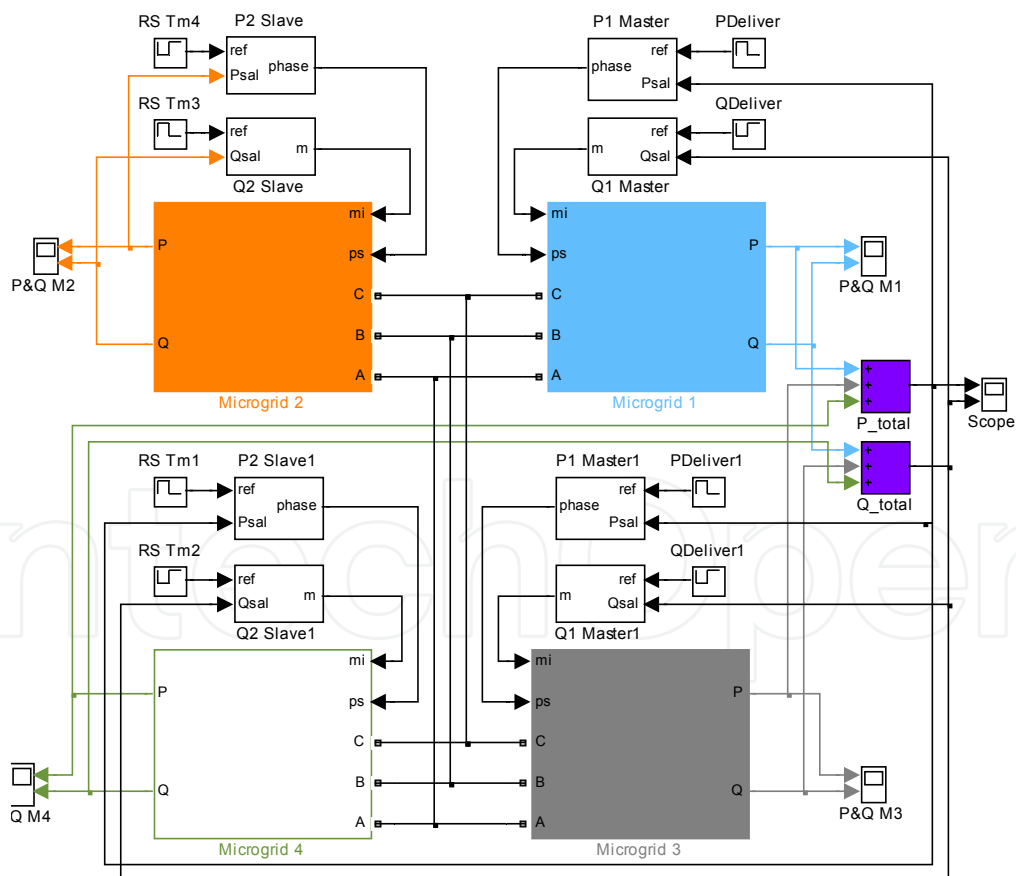

Fig. 30. Power flow control in island MG

The results of the simulations can be seen in Fig.31 for $P_s = (-100, -40) \text{ W}$ and $Q_s = (-30, -20) \text{ VAR}$.

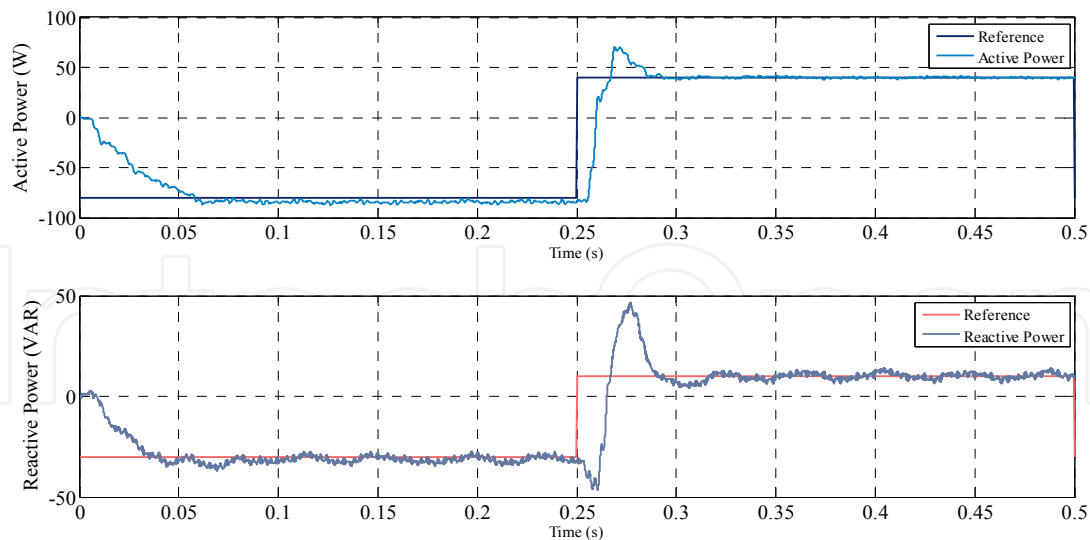

Fig. 31. Power flow control in island MG

5. Conclusion

The smart application schemes studied in this chapter show that the FLC can provide a suitable management for power converters and related developments with RES without an exact mathematical model and just the observed behaviour, due to its important features such as flexibility and adaptability to face high non-linearities and load changes in these kinds of systems.

Due to the local controllers have already been tested in previous developments, the next step in this research is to test the upper layer in an embedded system with the capability of real-time signal management and processing.

The hierarchical fuzzy architecture shown provides the opportunity to increase the autonomous and coordination actions in the converters involved giving a future idea about the low voltage MG to achieve self-healing or diagnose.

The addition of some extra rules in the higher control layer could generate an extensive computational process, however these rules would be necessary in a larger MG system or if it is required to improve other decisions.

If the VSC-Induction motor or VSC-Grid units are increased in large quantities or differ in their characteristics, the system model is increased and the complexity as well. A supervisory fuzzy control is suitable to manage them with the sole requirement to know the entire behaviour.

As a future work, it can be added another coordination targets such as the batteries charging converters, the dc-dc converters involved and the MPPT algorithms.

6. References

- Alajmi, B. (2010). Fuzzy Logic Control Approach of a Modified Hill Climbing Method for Maximum Power Point in Microgrid Stand-alone Photovoltaic System. *IEEE Transactions on Power Electronics*, Vol. 26, No. 4, (November 2010), pp. (1022 – 1030), ISSN : 0885-8993

- Ayob, S.M., Salam, Z. & Azli, N.A. (2006). Simple PI Fuzzy Logic Controller Applied in DC-AC Converter, *Proceedings of International Power and Energy Conference*, ISBN: 1-4244-0273-5, Putrajaya, Malaysia, November 2006
- Bai, Y; Zhuang, H & Wang, D. (2006) Advanced Fuzzy Logic Technologies in Industrial Applications, Series: Advances in Industrial Control. Springer-Verlag 2006
- Balaguer, I.J.; Qin, L; Shuitao, Y; Supatti, U. & Fang Z. P. (2011) Control for Grid-Connected and Intentional Islanding Operations of Distributed Power Generation, *IEEE Transactions on Industrial Electronics*, Vol.58, No.1, pp.147-157, Jan. 2011, ISSN: 0278-0046
- Bellini, A., Bifaretti, S. & Iacovone, V. (2010). A Zero-Voltage transition full bridge DC-DC converter for photovoltaic applications, *Proceedings of International Symposium on Power Electronics Electrical Drives Automation and Motion*, ISBN: 978-1-4244-4986-6, June 2010
- Binduhewa, P.J.; Renfrew, A.C. & Barnes, M. (2008). MicroGrid Power Electronics Interface for Photovoltaics," *Proceedings of IET Conference on Power Electronics, Machines and Drives*, ISSN: 0537-9989, April 2008
- Bor-Ren L. & Chihchiang H. (1993). Buck/Boost Converter Control with Fuzzy Logic Approach, *Proceedings of International Conference on Industrial Electronics, Control, and Instrumentation*, ISBN: 0-7803-0891-3, November 1993
- Bor-Ren L. & Hoft, R.G. (1993). Power Electronics Converter Control based on Neural Network and Fuzzy Logic Methods, *Proceedings of Power Electronics Specialists Conference*, ISBN: 0-7803-1243-0, June 1993
- Bose, A. (2010). Smart Transmission Grid Applications and Their Supporting Infrastructure, *IEEE Transactions on Smart Grid*, Vol.1, No.1, (June 2010), pp.11-19, ISSN: 1949-3053
- Bose, B.K. (1984) Scalar Decoupled Control of Induction Motor. *IEEE Transactions on Industry Applications*, Vol.IA-20, No.1, pp.216-225, Jan. 1984, ISSN: 0093-9994
- Bose, B.K. (2006). Intelligent Control and Estimation in Power Electronics and Drives, *Proceedings of International Power Electronics Congress*, ISBN: 1-4244-0544-0, October 2006
- Carmona-Sánchez, J.; Ruiz-Vega, D. (2010). Review of Static Induction Motor Models, *Proceedings of North American Power Symposium*, ISBN: 978-1-4244-8046-3, September 2010
- Cecati, C., Dell'Aquila, A., Liserre, M. & Ometto, A. (2003). A Fuzzy Logic based Controller for Active Rectifier, *IEEE Transactions on Industry Applications*, Vol.39, No.1, January 2003, pp. 105- 112, ISSN: 0093-9994
- Cecati, C., Dell'Aquila, A., Lecci, A. & Liserre, M. (2005). Implementation Issues of a Fuzzy Logic based Three-Phase Active Rectifier Employing only Voltage Sensors," *IEEE Transactions on Industrial Electronics*, Vol.52, No.2, April 2005, pp. 378- 385, ISSN: 0278-0046
- Corcau, J.I., Coman, A., Dinca, L. & Grigorie, T. (2010). Study of Fuzzy Logic Controller for ZCS Boost Converter, *Proceedings of Electrical Systems for Aircraft, Railway and Ship Propulsion*, ISBN: 978-1-4244-9092-9, October 2010
- Chamorro, H. R. & Trujillo, C. L. (2009). Switching Losses Analysis of a DC Link Fuzzy Logic Controller Scheme Applied to a VSC, *Proceedings of North American Power Symposium*, ISBN: 978-1-4244-4428-1, October 2009

- Chamorro, H.R. & Toro, B.W. (2010). Simultaneous Fuzzy Logic Control of a Three Phase Induction Motor Speed and Soft Switching DC link, *Proceedings of International Conference on Industry Applications*, ISBN: 978-1-4244-4428-1, Sao Paulo, Brasil, November 2010
- Chamorro, H.R., Diaz, N.L., Soriano, J.J. & Espitia, H.E. (2011). Active and Reactive Power Flow Fuzzy Controller for VSC HVDC using DBR and DBR Type 2, *Proceedings of Annual Meeting of the North American Fuzzy Information Processing Society*, ISBN: 978-1-61284-968-3, March 2011
- Chamorro, H.R. & Ramos, G. (2011). Microgrid Central Fuzzy Controller for Active and Reactive Power Flow using Instantaneous Power Measurements, *Proceedings of Power and Energy Conference at Illinois*, ISBN: 978-1-4244-8051-7, February 2011
- Chamorro, H. R., Toro, B., Trujillo, C; Guarnizo, G. (2009). Simulation and Hardware Verification of a PD Fuzzy Speed Controller for a Three Phase Induction Motor, *Proceedings of Electrical Power & Energy Conference*, ISBN: 978-1-4244-4508-0, October 2009
- Chaouachi, A., Kamel, R.M. & Nagasaka, K. (2010). Microgrid Efficiency Enhancement based on Neuro-Fuzzy MPPT control for Photovoltaic Generator, *Proceedings of Photovoltaic Specialists Conference*, ISBN: 978-1-4244-5890-5, June 2010
- Chung-Yuen Won, Duek, K, Bose, B.K. (1992). An Induction Motor Servo System with Improved Sliding Mode Control. *Proceedings of Industrial Electronics, Control, Instrumentation, and Automation*, ISBN: 0-7803-0582-5, November 1992
- Diaz, N.L., Barbosa, F.H. & Trujillo, C.L. (2007). Analysis and Design of a Nonlinear Fuzzy Controller Applied to a VSC to Control the Active and Reactive Power Flow, *Proceedings of Electronics, Robotics and Automotive Mechanics Conference*, ISBN: 978-0-7695-2974-5, September 2007
- Diaz, N.L., Barbosa, F.H. & Trujillo, C.L. (2008). Implementation of Nonlinear Power Flow Controllers to Control a VSC, *Proceedings of Power Electronics and Motion Control Conference*, ISBN: 978-1-4244-1741-4, September 2008
- Ding, M.; Zhang, Y.Y.; Mao, M.Q.; Yang, W.; Liu, X. P. (2010). Operation Optimization for Microgrids under Centralized Control. *Proceedings of International Symposium on Power Electronics for Distributed Generation Systems*, ISBN: 978-1-4244-5669-7, June 2010
- Elbuluk, M. & Idris, N.R. (2008). The Role Power Electronics in Future Energy Systems and Green Industrialization, *Proceedings of International Power and Energy Conference*, ISBN: 978-1-4244-2404-7, December 2008
- Ferreira, A.A., Pomilio, J.A., Spiazzi, G. & de Araujo, L. (2008). Energy Management Fuzzy Logic Supervisory for Electric Vehicle Power Supplies System, *IEEE Transactions on Power Electronics*, Vol.23, No.1, (January 2008), pp.107-115, ISSN: 0885-8993
- Forero, F.A.; Molina, A.M.; Guarnizo J.G. & Chamorro, H.R.. (2009). Implementation of Inverse Neural Control to VSC Converter for Active and Reactive Power Flow. *Proceedings of Intelligent System Applications to Power Systems*, ISBN: 978-1-4244-5097-8, November 2009
- Guangkai, L; Gengyin, L; Haifeng, L; Chengyong, Z & Ming Yin. (2006). Research on Dynamic Characteristics of VSC-HVDC System. *Proceedings of Power Engineering Society General Meeting*, ISBN: 1-4244-0493-2.

- Haifeng, L; Gengyin, L, Ming, Z. & Chengyong, Z., The Implementation of Fuzzy Adaptive PI Controller in VSC-HVDC Systems, *Proceedings of Power Systems Conference and Exposition*, ISBN: 978-1-4244-3810-5, March 2009
- Momoh, J.A. (2009). Smart Grid Design for Efficient and Flexible Power Networks Operation and Control, *Proceedings of Power Systems Conference and Exposition*, ISBN: 978-1-4244-3810-5, March 2009
- Papadimitriou, C.N. & Vovos, N.A. (2010). A Fuzzy Control Scheme for Integration of DGs into a Microgrid, *Proceedings of Mediterranean Electrotechnical Conference*, ISBN: 978-1-4244-5793-9, April 2010
- Kasa, N., Iida, T. & Bhat, A.K. (2005). Zero-Voltage Transition Flyback Inverter for Small Scale Photovoltaic Power System, *Proceedings of Power Electronics Specialists Conference*, ISBN: 0-7803-9033-4, June 2005
- Kolokolov, Y., Koschinsky, S.L. & Hamzaoui, A. (2004). Comparative Study of the Dynamics and Overall Performance of Boost converter with Conventional and Fuzzy Control in Application to PFC, *Proceedings of Power Electronics Specialists Conference*, ISBN: 0-7803-8399-0, June 2004
- Lasseter, B. (2001). Microgrids [distributed power generation], *Proceedings of Power Engineering Society Winter Meeting*, ISBN: 0-7803-6672-7, Feb 2001
- Liu, Z; Shao, W; Song, Q & Liu, W. (2009) A Novel Nonlinear Decoupled Controller For VSC-HVDC System. *Proceedings of Power and Energy Engineering Conference*, ISBN: 978-1-4244-2486-3, March 2009
- Mattavelli, P., Rossetto, L., Spiazzi, G. & Tenti, P. (1997). General-Purpose Fuzzy Controller for DC-DC Converters," *IEEE Transactions on Power Electronics*, Vol.12, No.1, January 1997, pp.79-86, ISSN: 0885-8993
- Matsugae, H., Hatchisu, Y., Nagao, Y. & Fujita, K. (1990). DSP-based all Digital, Vector Control Induction Motor Drives for Spindle System. *Proceedings of Power Electronics Specialists Conference*, Jun 1990
- Mokrytzki, B. (1991) Survey of Adjustable Frequency Technology-1991. *Proceedings of Industry Applications Society Annual Meeting*, ISBN: 0-7803-0453-5, October 1991
- Peng, F.Z.; Yun Wei Li; Tolbert, L.M. (2009). Control and Protection of Power Electronics Interfaced Distributed Generation Systems in a Customer-driven Microgrid, *Proceedings of Power & Energy Society General Meeting*, ISBN: 978-1-4244-4241-6, July 2009
- Rashid, M. (2001). *Power Electronics Handbook*, Academic Press, ISBN: 012-581650-2, Canada
- Sadeghzadeh, S.M. & Ansarian, M., (2006). Transient Stability Improvement with Neuro-Fuzzy Control of FACTS Devices, *Proceedings International Power and Energy Conference*, ISBN: 1-4244-0273-5, November. 2006
- Singh, B.; Panigrahi, B.K. & Mohan, D.M. (2006) Voltage Regulation and Power Flow Control of VSC Based HVDC System. *Proceedings of International Conference on Power Electronics, Drives and Energy Systems*, ISBN: 0-7803-9772-X, December 2006
- Shireen, W., Misir, D., Malki, H. & Arefeen, M.S. (1996). A Soft Switching Scheme for a PWM Inverter using a Fuzzy Logic Controller. *Proceedings of Telecommunications Energy Conference*, ISBN: 0-7803-3507-4, October 1996
- Shireen, W. & Arefeen, M.S. (1994). A DC Voltage Notching Scheme for Zero Voltage Switching (ZVS) of PWM Inverters, *Proceedings of Industry Applications Society Annual Meeting*, ISBN: 0-7803-1993-1, October 1994

- Shireen, W. & Patel, S. (2011). Fast converging digital MPPT control for photovoltaic (PV) applications. *Proceedings of Power and Energy Society General Meeting*, ISBN: 978-1-4577-1000-1, July 2011
- Simoes, M. (2006). Intelligent based Hierarchical Control Power Electronics for Distributed Generation Systems," *Proceedings of Power Engineering Society General Meeting*, ISBN: 1-4244-0493-2, October 2006
- Sivakumar, M., Jickson, C.J. (2011) A Fuzzy based Power Quality Enhancement Strategy for AC-AC Converters, *Proceedings of National Conference on Innovations in Emerging Technology*, ISBN: 978-1-61284-807-5, February 2011
- Takahashi, I. & Ohmori, Y. (1989). High-Performance Direct Torque Control of an Induction Motor, *IEEE Transactions on Industry Applications*, Vol.25, No.2, pp.257-264, March 1989, ISSN: 0093-9994
- Xiaodong, L & Ilochonwu, O. (2011). Induction Motor Starting in Practical Industrial Applications," *IEEE Transactions on Industry Applications*, Vol.47, No.1, (February 2011) pp.271-280, ISSN: 0093-9994.
- Zadeh, L.A. (1994). Fuzzy logic: issues, contentions and perspectives," *Proceedings of International Conference on Acoustics, Speech, and Signal Processing*, ISBN: 0-7803-1775-0, vol.vi, April 1994

IntechOpen

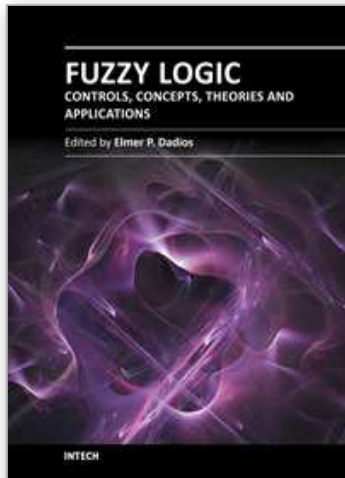

Fuzzy Logic - Controls, Concepts, Theories and Applications

Edited by Prof. Elmer Dadios

ISBN 978-953-51-0396-7

Hard cover, 428 pages

Publisher InTech

Published online 28, March, 2012

Published in print edition March, 2012

This book introduces new concepts and theories of Fuzzy Logic Control for the application and development of robotics and intelligent machines. The book consists of nineteen chapters categorized into 1) Robotics and Electrical Machines 2) Intelligent Control Systems with various applications, and 3) New Fuzzy Logic Concepts and Theories. The intended readers of this book are engineers, researchers, and graduate students interested in fuzzy logic control systems.

How to reference

In order to correctly reference this scholarly work, feel free to copy and paste the following:

Harold R. Chamorro and Gustavo A. Ramos (2012). Fuzzy Control in Power Electronics Converters for Smart Power Systems, Fuzzy Logic - Controls, Concepts, Theories and Applications, Prof. Elmer Dadios (Ed.), ISBN: 978-953-51-0396-7, InTech, Available from: <http://www.intechopen.com/books/fuzzy-logic-controls-concepts-theories-and-applications/fuzzy-control-in-power-electronics-converters-for-smart-power-systems>

INTECH
open science | open minds

InTech Europe

University Campus STeP Ri
Slavka Krautzeka 83/A
51000 Rijeka, Croatia
Phone: +385 (51) 770 447
Fax: +385 (51) 686 166
www.intechopen.com

InTech China

Unit 405, Office Block, Hotel Equatorial Shanghai
No.65, Yan An Road (West), Shanghai, 200040, China
中国上海市延安西路65号上海国际贵都大饭店办公楼405单元
Phone: +86-21-62489820
Fax: +86-21-62489821

© 2012 The Author(s). Licensee IntechOpen. This is an open access article distributed under the terms of the [Creative Commons Attribution 3.0 License](#), which permits unrestricted use, distribution, and reproduction in any medium, provided the original work is properly cited.

IntechOpen

IntechOpen