

We are IntechOpen, the world's leading publisher of Open Access books Built by scientists, for scientists

4,800

Open access books available

122,000

International authors and editors

135M

Downloads

Our authors are among the

154

Countries delivered to

TOP 1%

most cited scientists

12.2%

Contributors from top 500 universities



WEB OF SCIENCE™

Selection of our books indexed in the Book Citation Index
in Web of Science™ Core Collection (BKCI)

Interested in publishing with us?
Contact book.department@intechopen.com

Numbers displayed above are based on latest data collected.
For more information visit www.intechopen.com



Lightweight Plastic Materials

Marek Kozłowski
Wrocław University of Technology
Poland

1. Introduction

Lightweight constructions are increasingly used in automotive, aerospace and construction sectors, because using the low density materials allows reducing the structural weight of products. That may result in substantial fuel savings and a lower carbon footprint in transportation and facilitates manipulation of details in the house construction applications. Moreover, the low material density leads to conservation of natural resources, since less material is required for manufacturing consumer goods.

In polymer engineering the lightweight solutions include:

- selection of polymers with a density lower than their counterparts of comparable properties,
- using composites filled with natural fibers instead of glass fibers,
- composite sandwich panels with cellular/honeycomb structure,
- hollow components manufactured by the gas or water assisted injection molding,
- polymer foaming.

Cellular and hollow structure polymeric materials offer additional advantages resulting from their thermal insulating properties, thus allowing additionally energy savings.

Preference given to low density materials belong to the factors deciding on a success of polypropylene (PP) in the automotive sector. Being lighter than other plastics for 15-20% PP allows substantial fuel savings – it is assumed that a weight reduction in a car body of 100 kg brings about 0.3-0.5 litres of fuel savings per 100 km.

2. Biocomposites

Polymer composites constitute a broad group of materials, composed of the macromolecular matrix and various fillers. Currently the filler market for plastic composites is dominated by calcium carbonate (40%) and glass fiber (31%) and some other inorganic fillers such as talc, mica and clay. Although the conventional fillers offer property changes in the composites, their high density is not beneficial to fuel savings in automotive applications. Polymer composites with cellulose fillers are growing rapidly, mainly in the construction and automotive industry. The main advantage of such composites is lower density in comparison to that of glass fiber reinforced plastics. In Fig. 1 the density of polypropylene and PP filled with wood flour (WF), without or with of a compatibilizer (PP/WF/comp) has

been compared to that of PP composites with glass fibers (GF). One can observe an increase in density with the filler content for all composites, however markedly higher density is that of PP/GF materials.

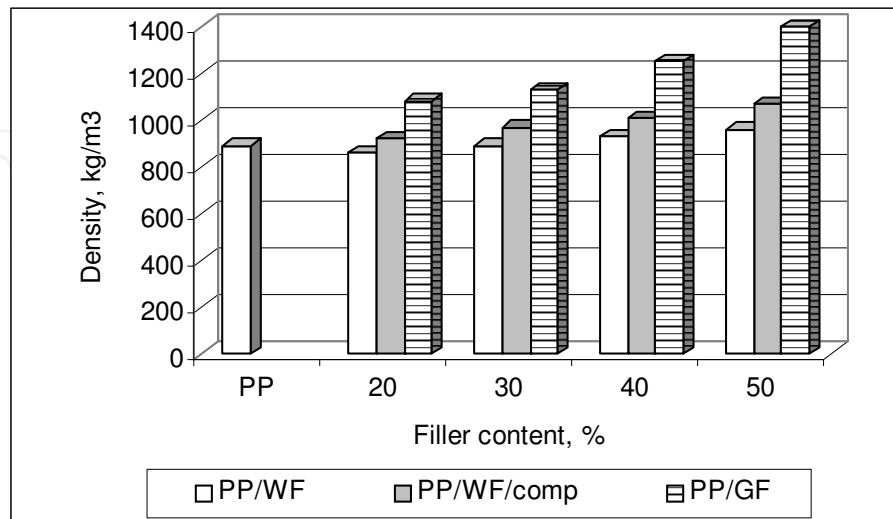

Fig. 1. Density of polypropylene and PP composites with wood flour

Low density of polymer composites filled with natural fibers was received due to a specific hollow structure of the fibers (Fig. 2), which is totally different from a bulky structure of glass fibers. Cellulose fibers do not exist in nature as separate items, but they form bundles. Each bundle contains 10-60 fibers diameter of 10-17 microns, linked together with pectines.

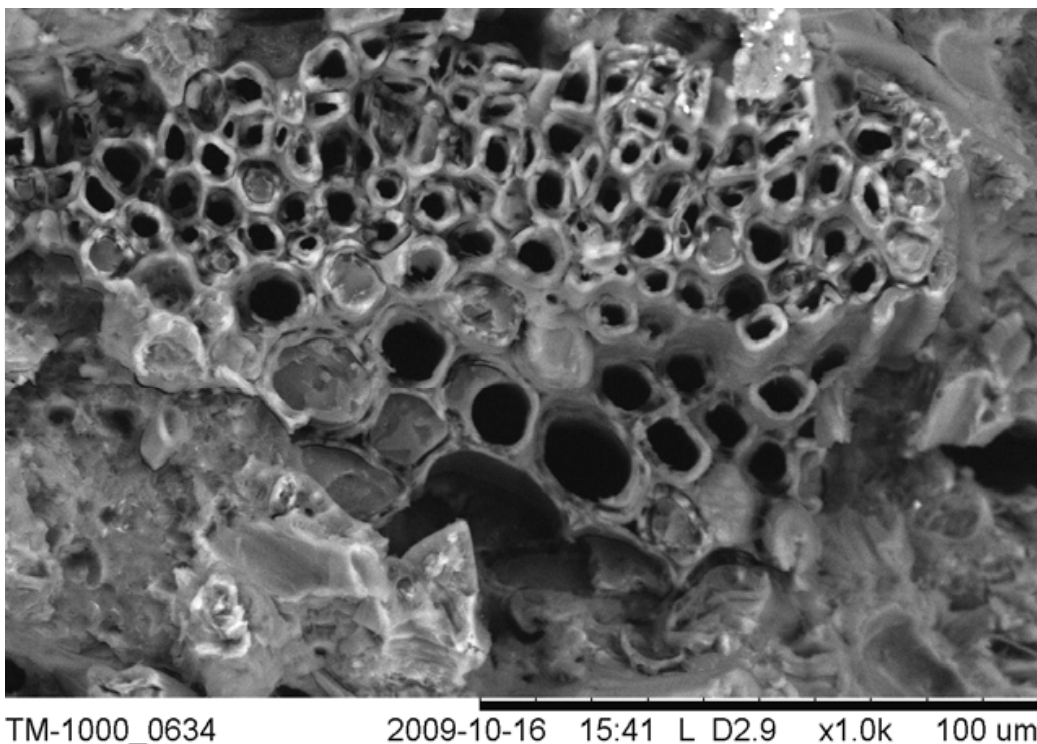

Fig. 2. Flax fibers bundle cross-section

Natural fillers are biodegradable and derive from renewable resources, which is highly advantageous for sustainable development (Ellison et al., 2004; Bledzki et al., 2008; Oksman Niska & Sain, 2008; Klesov, 2007; Kozłowski & Kozłowska, 2005). Apart from the ecological reasons, natural fillers offer possibility of reinforcing thermoplastic matrices (Figs. 3 and 4) and provide weight savings in comparison to glass fibers (Table 1).

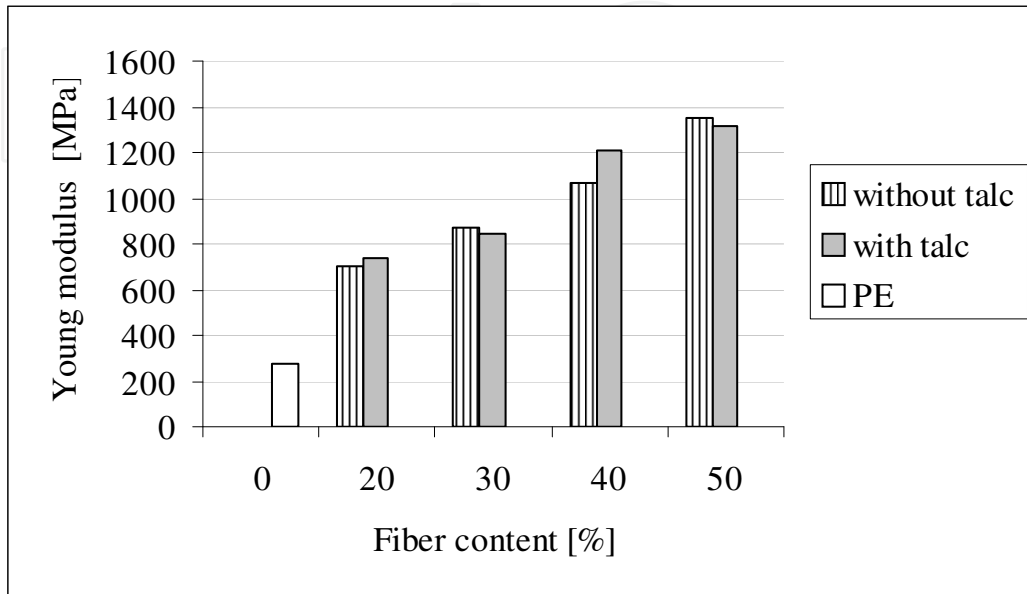

Fig. 3. Young modulus of LDPE and LDPE composites with hemp fibers

Increase in the stiffness of thermoplastic composites filled with cellulose fibers depends on a matrix polymer nature – it is particularly significant to composites based on the low density polyethylene (LDPE). In case of LDPE filled with 30wt.% of hemp fibers Young modulus increased for 300%, whereas at 50% loading it is for 5-times higher (Fig. 3).

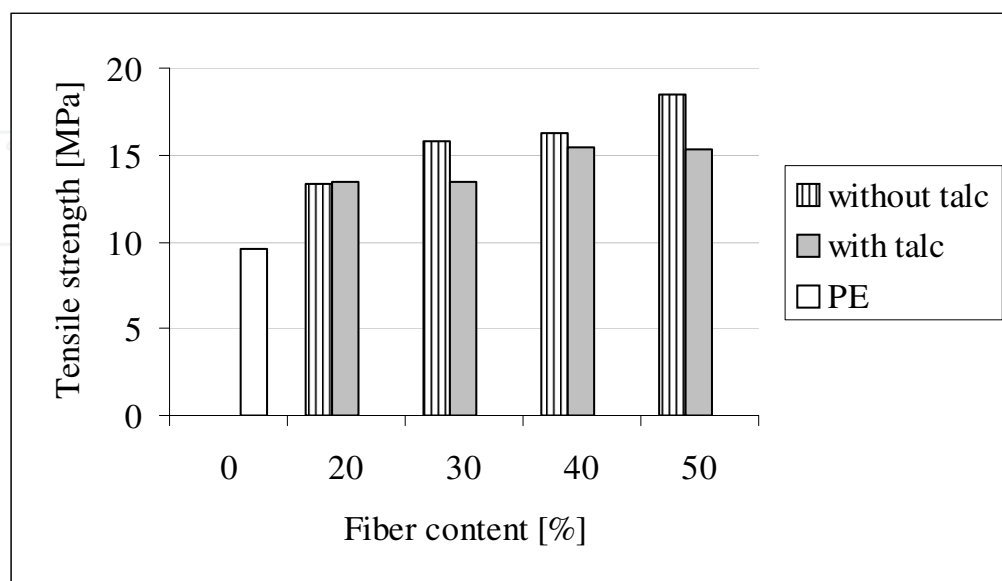

Fig. 4. Tensile strength of LDPE and LDPE composites with hemp fibers

Tensile strength of LDPE composites filled with natural fibers also enhances as a function of the filler content – at 30wt.% an increase for 60% was observed in comparison to neat LDPE, while at 50wt.% of hemp fibers the improvement reached 100% (Fig. 4).

Looking at the data presented in Table 1 and considering that the glass-fibre reinforced polypropylene composites are widely used in automotive components (front/end carriers, door panel supports, dashboards, consoles, seat backs, headliners, package trays, underbody shields etc.) one should expect significant environmental profits from replacing glass fibers with natural fibers (NF).

	PP	Natural fibers	Glass fibers
Price [€ / kg]	1.4	2.2-3.0	1.5-2.2
Density [g/cm ³]	0.92	1.2-1.5	2.5-2.8
Energy [MJ/kg]	101.1	3.4	48.3
CO ₂ [kg/kg]	3.11	0.64	2.04
SO _x [g/kg]	22.2	1.2	8.8
NO _x [g/kg]	2.9	0.95	2.9
BOD [mg/kg]	38.37	0.265	1.75
PM [g/kg]	4.37	0.2	1.03
COD [g/kg]	1.14	3.23	0.02

Table 1. Comparison of data related to materials used for manufacturing modern composites

The fibers used most frequently for reinforcement of polymer composites are the bast fibers grown in the climate of Europe (flax and hemp) and sub-tropical fibers (kenaf, jute and sisal) imported mainly from Asia. Composites filled with wood/natural fibers are called biocomposites or wood polymer composites (WPC), sometimes also a term “artificial wood” is applied. Their properties combine higher stiffness, hardness and better dimensional stability in comparison to plastics and lower density in comparison to mineral fillers. Currently biocomposites are being used by Fiat, Ford, Opel, Daimler Chrysler, Saturn, BMW, Audi, Peugeot, Renault, Mercedes Benz and Volvo.

Different polymers can be used as a matrix for biocomposites, and the loading of cellulose fillers usually vary within a range of 10 to 70%. Although thermosets were used first as a matrix for wood composites, currently thermoplastics use to be applied for manufacturing of biocomposites. Most frequently used matrices are polypropylene, polyethylene, polyvinylchloride and polystyrene. Depending on a chemical structure of the matrix the interaction at the polymer-filler interface is of different strength. This is crucial for the mechanical properties and melt viscosity of composites. High adhesion is expected if both components have polar groups. Unfortunately, this is not a case of the most popular biocomposites, which are composed of hydrophobic polyolefines and hydrophilic cellulose fibers (-OH groups). Therefore, extensive research has been performed to enhance interfacial adhesion and improve dispersion of cellulosic fibers in polyolefines. Frequently used solution is addition of compatibilizers composed of blocks interacting on a physical or chemical way with each component of the composite. Good results are reported on using maleated polypropylene (PP-g-MAH) for compatibilization of PP-based composites with

natural fillers (Fig. 1). Another approach might be hydrophobisation of cellulose fibers (esterification). Although polymer composites with natural fillers have been commercialized, their industrial applications are in some sectors limited because of their low impact strength and high density compared to natural wood and polyolefines.

The original processing technology of biocomposites was nonwoven technology, which is a normal production precursor to compression moulding. Further developments extended the processing technology to extrusion or injection molding of composites reinforced with short cellulose fibers. What should be considered at processing of thermoplastic composites is the melt viscosity, which increases after addition of fillers. Melt flow rate (MFR) of LDPE and composites with hemp fibers has been presented in Fig. 5. Flowability of composite filled with 30wt.% of fibers is for 2.5 times lower than that of neat LDPE, dropping down at 50wt.% of hemp for 6 times in comparison to MFR of polyethylene. For that reason either higher pressure or higher processing temperature has to be used in order to shape high quality products.

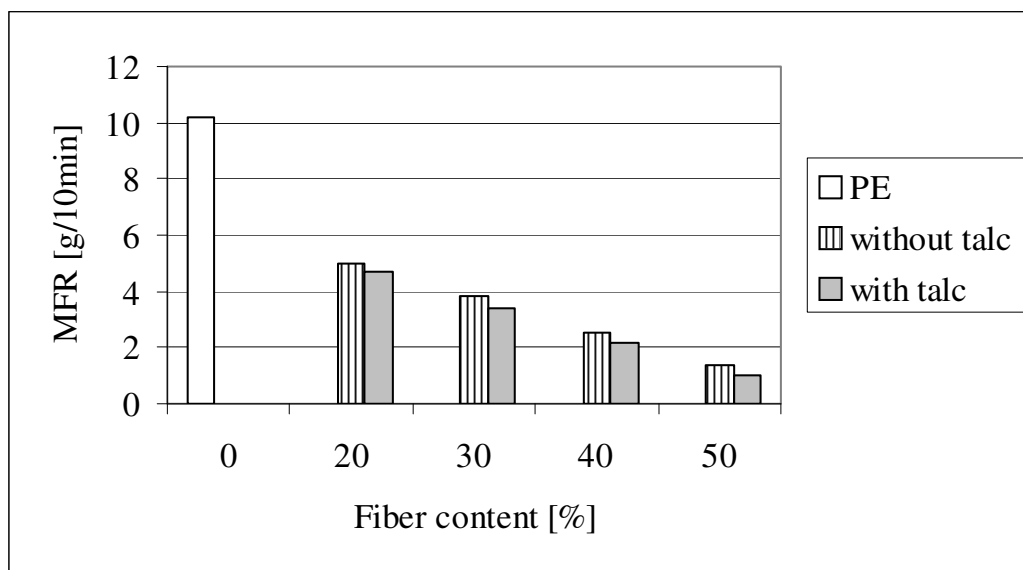

Fig. 5. Melt flow rate of LDPE and LDPE composites with hemp fibers

Particular type of biocomposite is the particle board, which is a composite material made from small pieces of wood or other lignocellulosic material (branches, stem, saw dust, straw or bagasses) that are mechanically pressed into sheets being bonded with a resin. Similar sandwich structure have composites which external skin layers are made of a bulky plastic, whereas a core is lightweight (density of 40-70 kg/m³), made either as a foam or honeycomb structure. Such sandwich materials (Panelplus panels) while used in the manufacture of truck bodies weigh 60% less than the equivalent plywood panels (Institute of Materials, Minerals and Mining, 2004).

Hollow, lightweight plastic components may be manufactured also by the gas or water assisted injection molding. In this technology the mould is only partially filled with a polymer melt, afterwards a gas or water is injected to pack the mould completely. After mold cooling and solidification of a polymer the gas or water is evacuated from the cavity and the hollow part is ejected (Fig. 6).

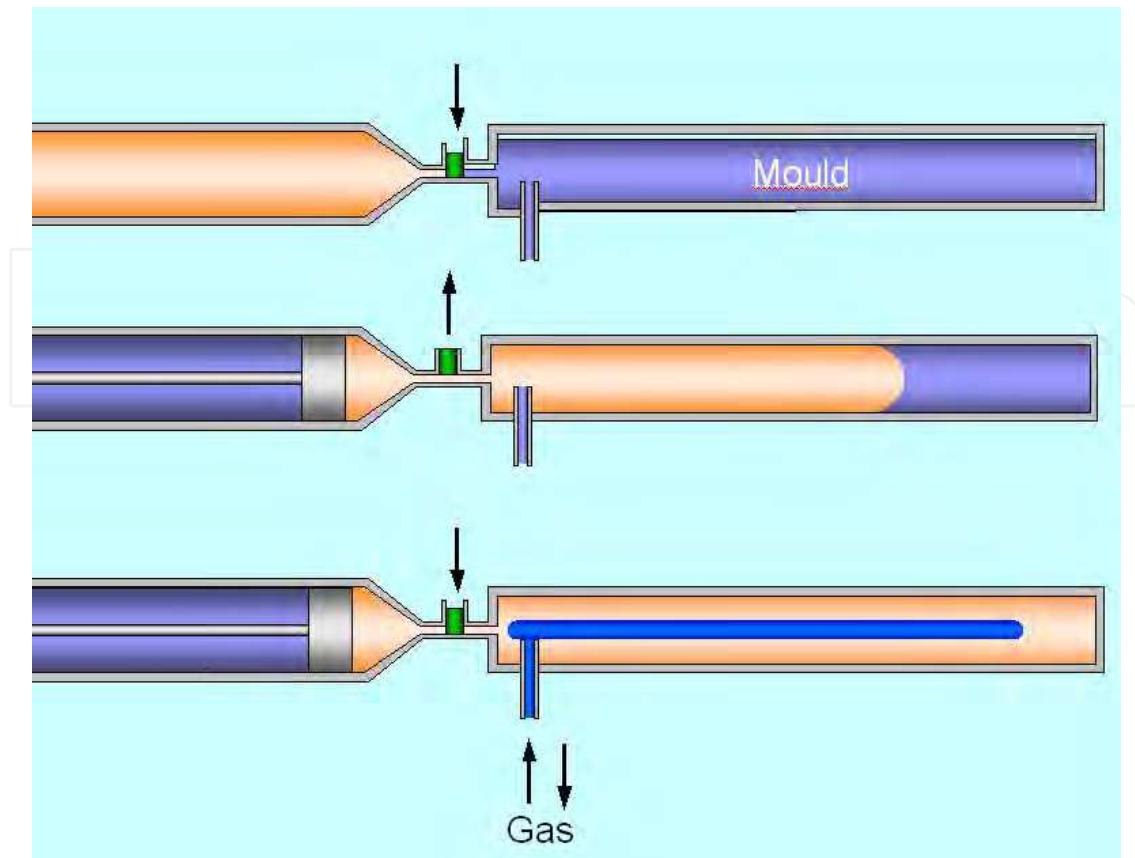

Fig. 6. Principle of gas-assisted injection molding (acc. to www.cinpres.net)

3. Polymer foaming

In parallel with other technologies a fast development in foaming technology of plastic parts is observed, driven primarily by the transportation sector demands. The main reason is that porous components allow to reduce the amount of raw materials and fuel consumption at the same time. Another characteristic of foams is thermal insulation, therefore an important application field is insulation of buildings and industrial constructions. A typical example is polystyrene foam, which is used in the construction industry for over 50 years. Polyurethane and polyethylene foams have been used for insulations of pipelines, air ducts, containers, solar collectors etc. (Fig. 7). Plastic foams are used extensively for thermal insulation of refrigerators and freezers.



Fig. 7. Foam insulation made of synthetic rubber ARMAFLEX HT (www.azflex.pl)

Cellular structure of foams allows also sound and vibration damping, which has been used in sound insulating panels, upholstery in furniture, car seats, protective pads etc.

Cellular plastics may be manufactured either by the periodic or continuous technology, using chemical or physical foaming agents. The conventional foams have cells of large size (0.1-1 mm) and broad size distribution (Fig. 8), therefore their mechanical properties are inferior to that of bulky polymers. The cell density of conventional foams is in a range of 10^4 - 10^6 cells/cm³.

The microfoams contain much higher number of cells ($>10^9$ /cm³), which size is markedly smaller (ca. 10 μ m). Such materials exhibit better performance than the conventional foams, with higher mechanical properties and better thermal insulating characteristics.

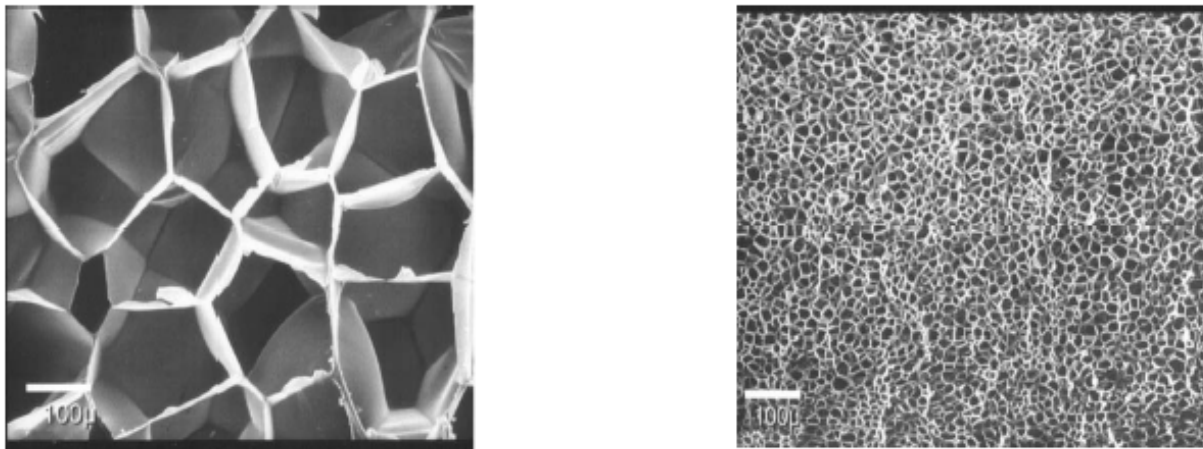

Fig. 8. Polystyrene foams – conventional (left) and microfoam (www.trexel.com)

3.1 Methods of foaming

Foaming techniques can be divided into several groups. Similar to the plastics processing technology, they can be divided on continuous (extrusion foaming) and periodic (injection molding or press foaming) processes. Periodic technology requires a long time and excluding manufacturing of expanded polystyrene (EPS), they are rarely applied.

Other method of rather seldom use is manufacturing of polymer composites filled with easily soluble compounds, like salt or sugar. After the filler is eluted with an appropriate solvent, the empty holes form cells of the resulted foam.

Cellular structure can be also formed by sintering of polymer powders at high temperature. Soft surfaces of neighboring spheres stick each other, whereas the free volumes between them create foam cells.

Akzo Nobel offers a foaming method based on mixing of a matrix polymer with thermoplastic spheres filled with volatile hydrocarbons (Expancel). At heating the polymer becomes soft, while the hydrocarbon evaporates, expanding the material. Initial sphere diameter is 12 μ m, which after expansion increases to 40 μ m. The material of spheres should be compatible with the matrix polymer, whereas a hydrocarbon is selected depending on a required decomposition temperature. The spheres of Expancel are added to a polymer in an

amount of 2 - 8% and such mixture is processed by extrusion or injection molding technology. Decrease in a density for 30% was reported after addition of 3% microspheres, however the cells were of diverse size (Fig. 9).

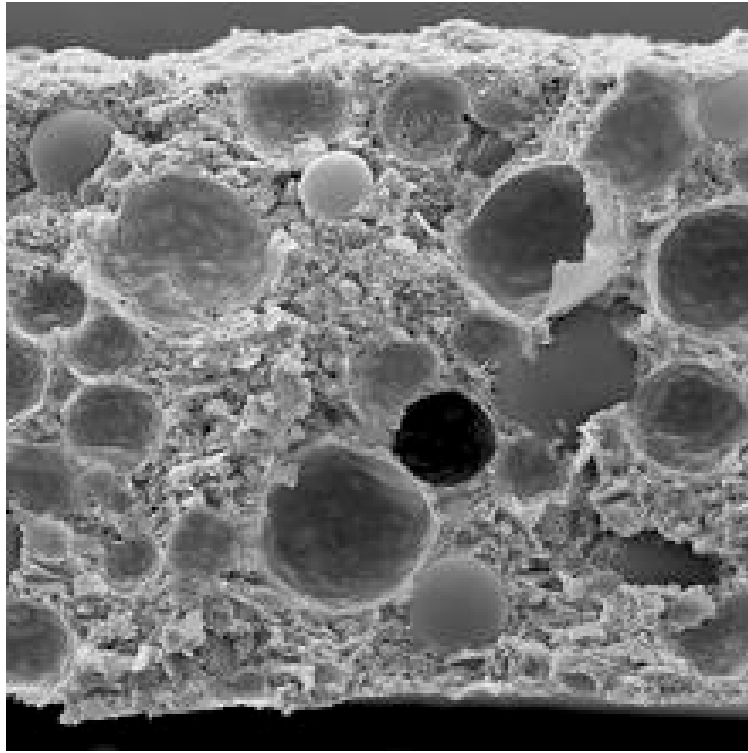

Fig. 9. Structure of foam manufactured with Expancel technology (www.akzonobel.com)

Undoubtedly the principal polymer foaming technology is that involving a gas delivered to a polymer by means of the chemical (CFA) or physical foaming agent (PFA). Low density foams (2 - 500 kg/m³) are manufactured with physical blowing agents, whereas chemical blowing agents produce foams density of 500 - 750 kg/m³.

3.2 Foaming agents

Physical blowing agents comprise of gases and low boiling hydrocarbons or their halogenated derivatives. Initially used blowing agents (pentane, butane, chlorofluoro hydrocarbons) are withdrawn because of ecological reasons (the Montreal Protocol Agreement) and fire hazard and replaced by noble gases (argone, nitrogen, carbon dioxide). Interesting properties have also hydrofluoro olefines, which have been used for manufacturing of polyurethane and EPS foams (Rosato, 2010).

Unfortunately several safe blowing agents exhibit either too low solubility in polymers or too high heat coefficient, which deteriorates thermo-insulating properties of foams. Thermal insulation expressed with the heat transfer coefficient λ depend on the cell size and density (Schellenberg & Wallis, 2010), but also on a nature of gas in the cells. Nitrogen and oxygen have comparable λ values (at 0°C respectively 22,7 and 23,2 mW/m K), however that of carbon dioxide equals to 13,7 mW/m K. Thus, the foams filled with CO₂ exhibit much better thermo-insulating properties than others.

Foaming with gases results mostly in foams of large cell size, however using supercritical liquids bring about manufacturing of microfoams (Cooper, 2000). At critical conditions (temperature and pressure) the density of a liquid and a gas equals. Above the critical temperature condensation of a gas is impossible, depending on a pressure applied. From that reason carbon dioxide is most appropriate for transportation, storage and dosing conditions, since its critical temperature is +31.1, whereas that for nitrogen is -146,9°C and argone -122,3°C.

Chemical blowing agents decompose within a specific temperature range, emitting a stechiometric amount of gases (usually nitrogen or carbon dioxide). Chemical blowing agents are classified as egzo- or endothermic, depending on the effect of a decomposition process. Due to a vigorous character of the decompositin reaction, egzothermic CBAs produce large size cells (>100 µm) of a non-uniform size distribution and cause a high overall expansion of the material (Fig. 10).

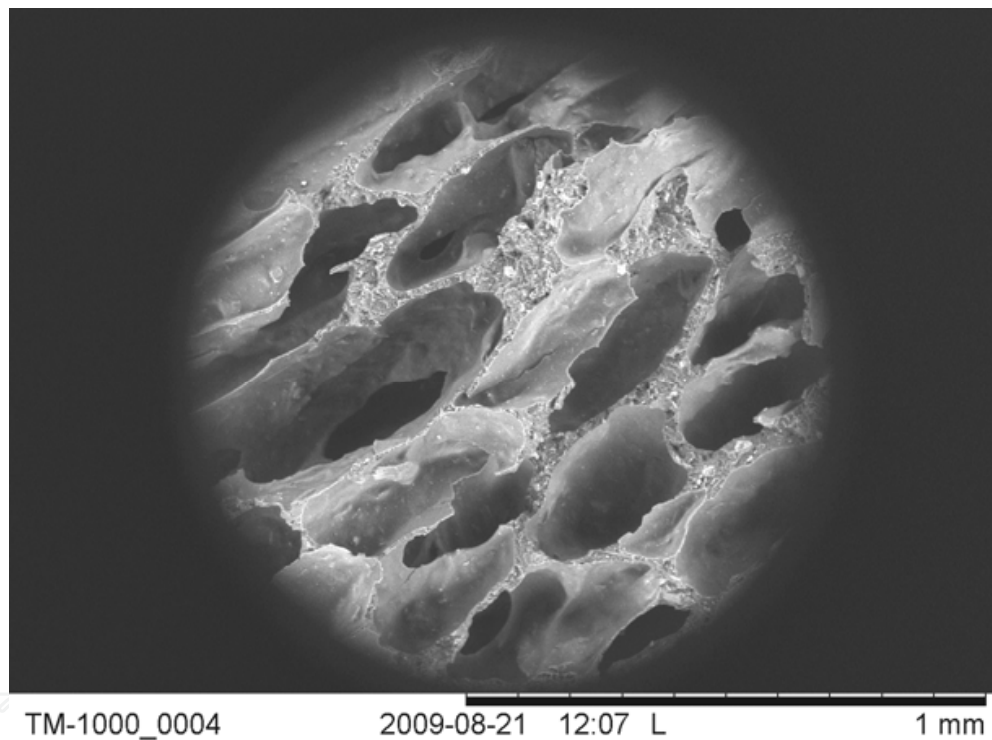

Fig. 10. Structure of polypropylene foam produced with egzothermic CBA

The most popular egzothermic chemical blowing agent is azodikarbonamide (ADC) $\text{H}_2\text{N}-\text{NH}-(\text{CO})-\text{N}=\text{N}-(\text{CO})-\text{NH}_2$. ADC decomposes at 200-220°C with emission of gases in the amount of 220 cm³/g. The mixture of gases comprises of nitrogen (65%), carbon monoxide (24%), carbon dioxide (5%) and ammonia (5%).

Endothermic chemical blowing agents need heat to continue decomposition, therefore it is easier to control the process just by changing its temperature. For that reason one can produce with endothermic CBA foams of lower cell size. Most popular endothermic blowing agent is a mixture of sodium hydrogen carbonate and citric acid. It decomposes to carbon dioxide and water in a two-stage reaction: first at 130-140°C, second at 180-200°C (Fig. 11).

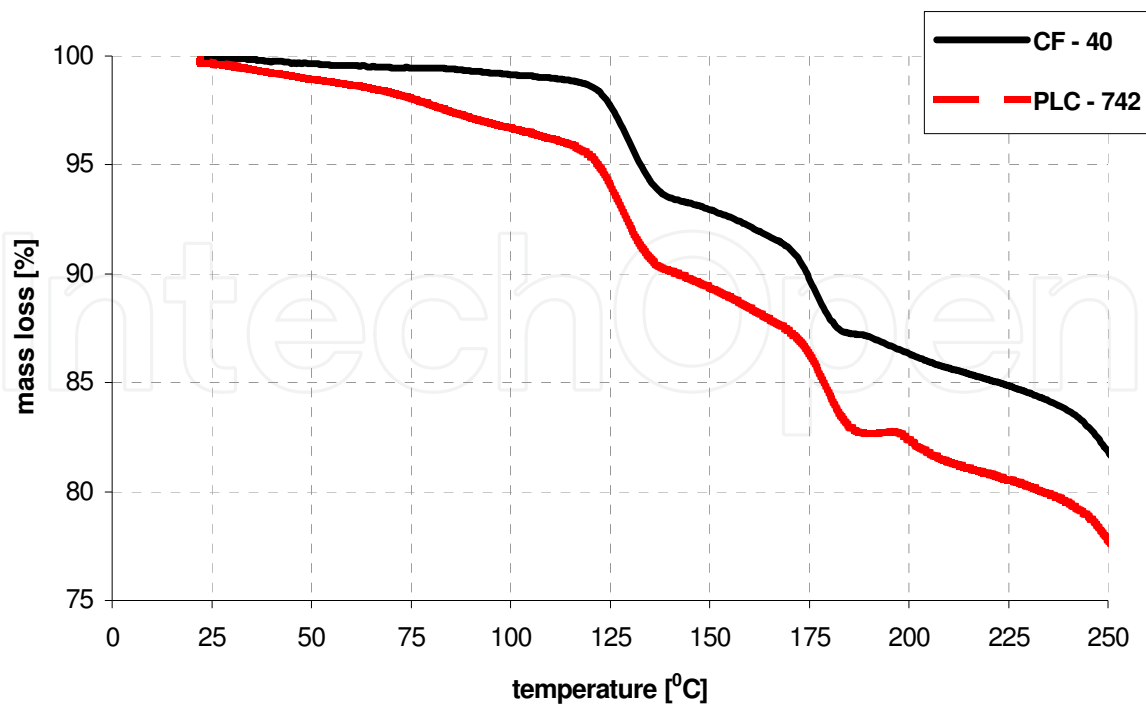
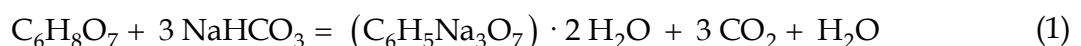

Fig. 11. TG analysis of endothermic chemical blowing agents

Decomposition takes place according to a reaction:



Total amount of gases emitted in the above reaction equals to 120 cm³/g.

Solubility of gases in polymers is a crucial factor for foaming. If it is high, the saturation time of a polymer with a gas is shorter and lower pressure level is required to keep the gas in the melt. Solubility of carbon dioxide in several polymers is higher than that of nitrogen, therefore it generates more cell nuclei, which is essential for the foam structure. The size of a foaming gas particle is also important for the foaming technology. Since CO₂ particle is small, it diffuses fastly through a polymer, which means that the cell growth rate should be high. However, from the other side, carbon dioxide may escape more easily to atmosphere, thus causing a collapse of the foamed material.

3.3 Technology of polymer foaming

Foaming process consists of four stages:

1. dissolving of a gas in a polymer under high pressure (if polymer is in a solid state) or at high temperature and high pressure (e.g. in a molten polymer);
2. cell nucleation due to a sudden change in the thermodynamic state of a material resulting from its decompression or temperature change;
3. cell growth - their size and density depend on the blowing agent content, process parameters and properties of the polymer;
4. morphology fixation by polymer solidification, e.g. cooling below the glass temperature or crosslinking.

Cellular polymers may be manufactured by saturation of a solid polymer with gas in a high pressure vessel at elevated temperature. First trials concerned foaming of polystyrene with carbon dioxide. It was evidenced that the equilibrium amount of CO₂ adsorbed by PS at 80°C under 240 bar pressure equals to 11.8%. The foam density varied within 0.05-0.85 g/cm³ depending on the applied temperature, pressure and pressure drop rate. The cell size amounted to 1-70 μm (Arora et al., 1998).

The foam morphology is related to a structure of polymers - the most important are branchings in the polymer chain and crystallinity (Huang et al., 2008; Rachtanpun et al., 2004; Su & Huang, 2010; Li et al., 2007). It is well established that foaming is easier with amorphous polymers like PS than with crystalline ones like polyolefines. Amorphous polymers usually have higher melt strength and are more viscous, therefore cell growth is more difficult, but they hold gas pores better. Crystalline resins are less viscous but difficult to foam due to their chain entanglement and crystals formation at cooling, which disturbs the cell growth process. Foaming of semicrystalline polymers is more complicated than the amorphous polymer foaming, because the gas dissolves exclusively in amorphous regions. That causes a non uniform cell nucleation and irregular foam morphology.

Temperature range of the efficient foaming is limited from above by the polymer degradation temperature and from a bottom by the polymer melt viscosity, which allows for a cell growth. Because it takes place only in the amorphous regions, fast increase in a viscosity of the semi-crystalline polymers upon cooling makes the available temperature range small in comparison to that of amorphous polymers.

Technology of a direct polymer saturation with a gas is useful rather for niche products due to a long time required for saturation because diffusivity of a gas in a solid polymer is low. Nevertheless, it may be used a. o. for scaffold manufacturing. Mooney et al. (1996) have shown that after treating copolymer of D,L lactic acid and glycolic acid with carbon dioxide under pressure of 5.5 MPa for 72 hours followed by fast decompression one observes cells in a polymeric material. Their size equals to ca. 100 μm, while the cell density depends on the process parameters and crystallinity of a polymer, reaching 93%.

Cell nucleation in a polymer starts spontaneously after a sudden change of a thermodynamic state of the system (homogeneous nucleation) or may be induced with addition of small amount of a filler (heterogeneous nucleation) (Lee, 2000; Lee et al., 2006).

Technology of foaming by means of extrusion or injection molding is more widely used, because a gas diffusion in molten polymers is faster and it is facilitated by mixing. These technologies were applied at late nineties at Massachusetts Institute of Technology (MIT) after the successful research on manufacturing PS microfoams by a solid state saturation with supercritical CO₂. Since then the foaming injection molding received an industrial maturity, providing remarkable material savings. Chen et al. (2006) presented an example of polypropylene foaming, showing that the material savings for thin wall (0.5 mm) items equals to 4-9% and for the thick wall (15 mm) samples reached 50%. Unfortunately, in parallel a deterioration of mechanical properties was reported. Similar findings were presented by Bielinski (2004), who tested foaming of polypropylene and polyvinyl chloride using chemical blowing agents. He has found that depending on the CBA content (0,5-2 wt.%) and injection molding parameters the cell size varied in a range of 10-350 μm.

The material savings and lower amount of waste cause that the chemical blowing agents are widely used. In Fig. 12 a yogurt cup made of PS foamed with CBA has been presented. The mass of a cup was decreased for 15-20% in comparison to the non-foamed item. Even if a foam structure is not uniform, the economical and ecological advantages are obvious.

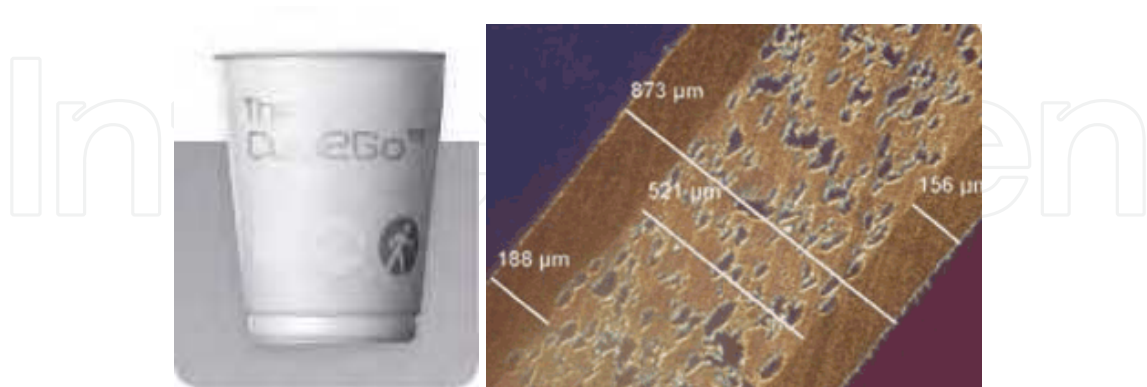

Fig. 12. Foamed polystyrene cup and its wall structure (acc. to www.adeka-palmarole.com)

Technology of microcellular foam extrusion has been extensively studied a.o. by Park and co-workers (Park, 2000; Lee & Park, 2006). After injection of a gas into the polymer melt its diffusion is intensified by mixing, which results in a complete gas dissolution. The equilibrium reached in the extruder is lost after the melt exits the die (Fig. 13). Sudden pressure decrease causes also decrease in a gas solubility, which has to evolve from a polymer in a form of microcells. These sites form nuclei, of which the larger cells grow as more gas appears in the system as the polymer melt-gas solution decompression proceeds. That process is continued until the new equilibrium state is reached or the polymer solidifies.

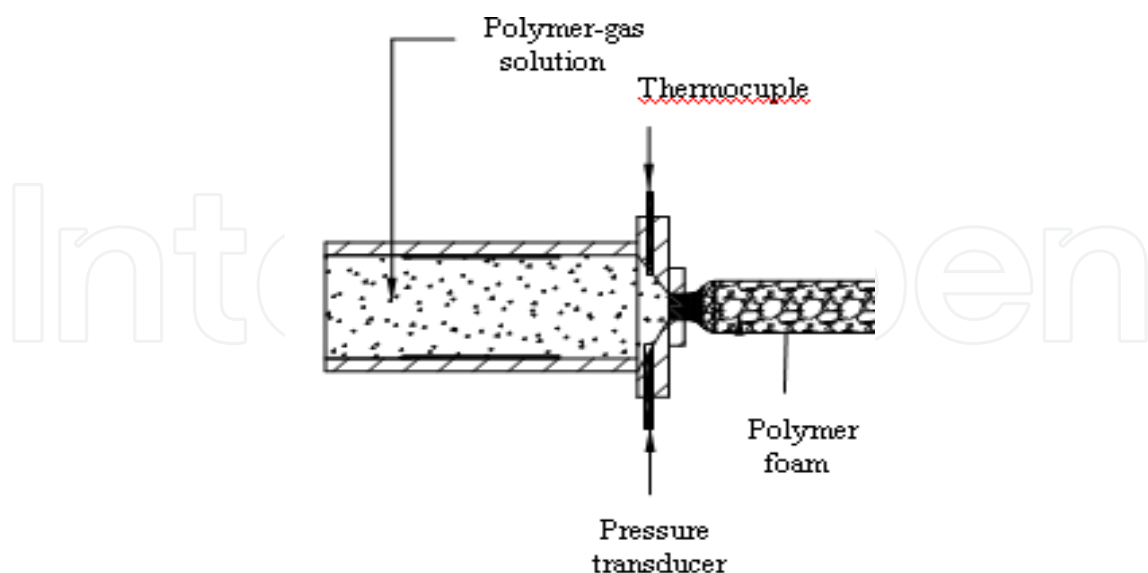

Fig. 13. Polymer foaming extrusion principle

Since foaming involves several processes occurring in a fluid state, therefore knowledge of the viscoelastic characteristics of a molten polymer is very important. Because the

dominating stresses are related with shearing and elongational forces, therefore a knowledge of a dependence of the polymer melt viscosity on temperature and on the shear rate is essential. In Figs. 14 and 15 the basic characteristics for three different LDPE grades have been presented.

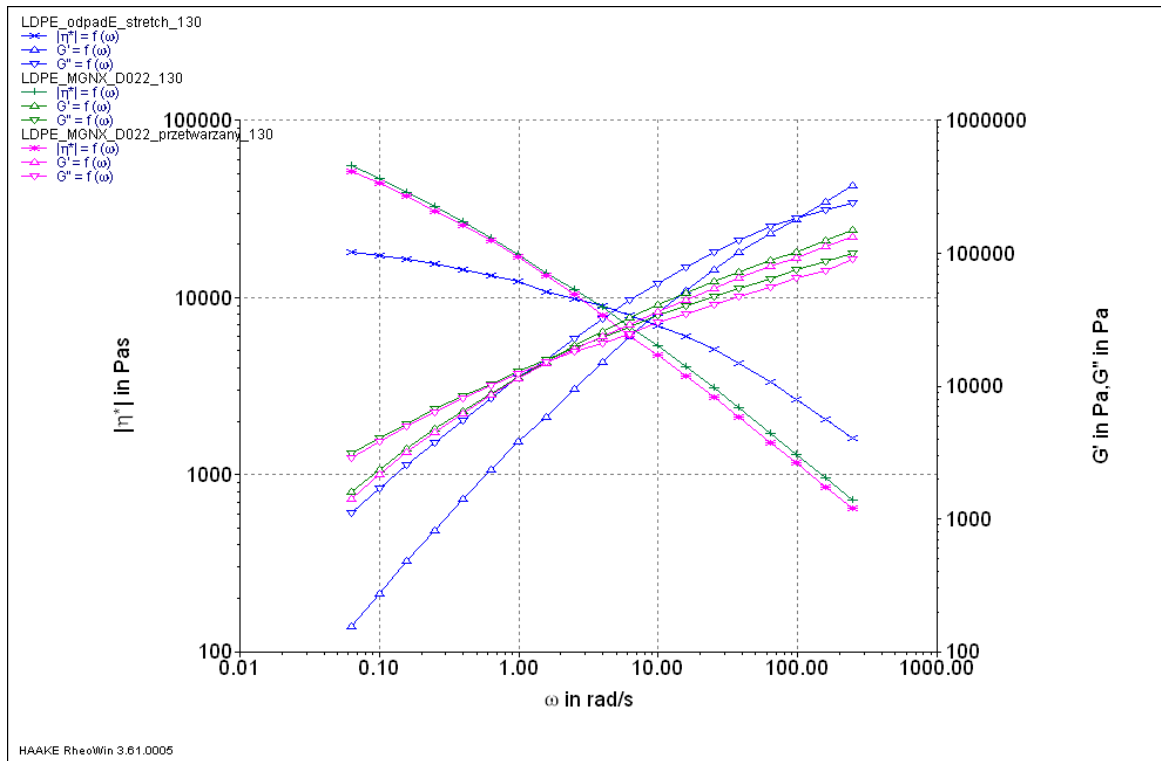

Fig. 14. Viscoelastic characteristics of different LDPE grades (130°C)

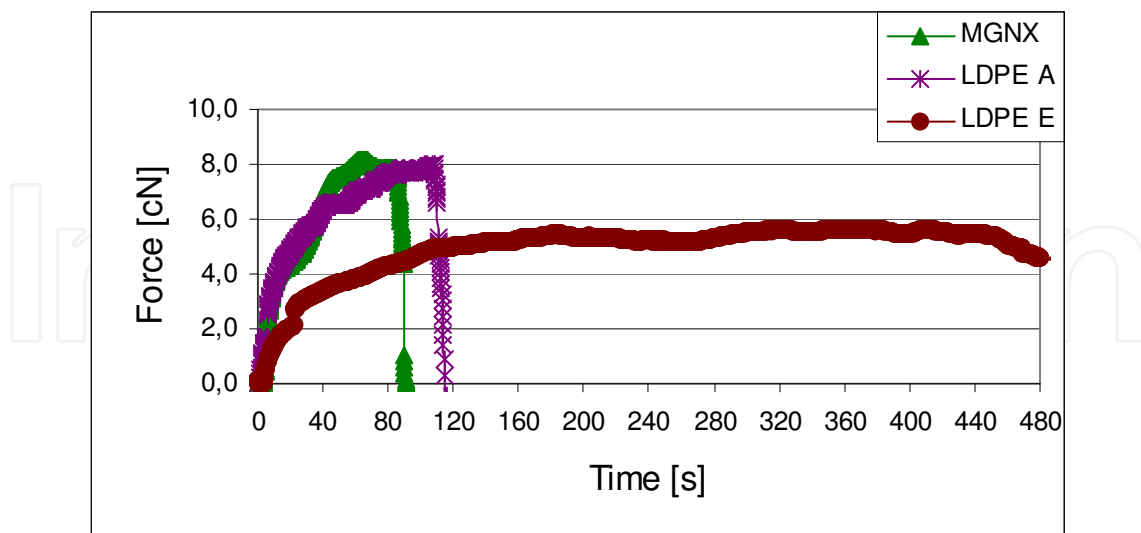

Fig. 15. Melt strength and elongation for different LDPE grades (130°C)

The examples show that different grades of the same polymer differ in pseudoplasticity, therefore they should exhibit diverse melt reaction at low and high deformation rates. That means a different mixing efficiency of the melt with a gas (torque level and gas diffusion

rate) and easy or more difficult cell grow (melt viscosity) and resistance to rupture (melt strength). One can expect that significant differences in viscoelastic properties should have an impact on morphology of cellular plastics.

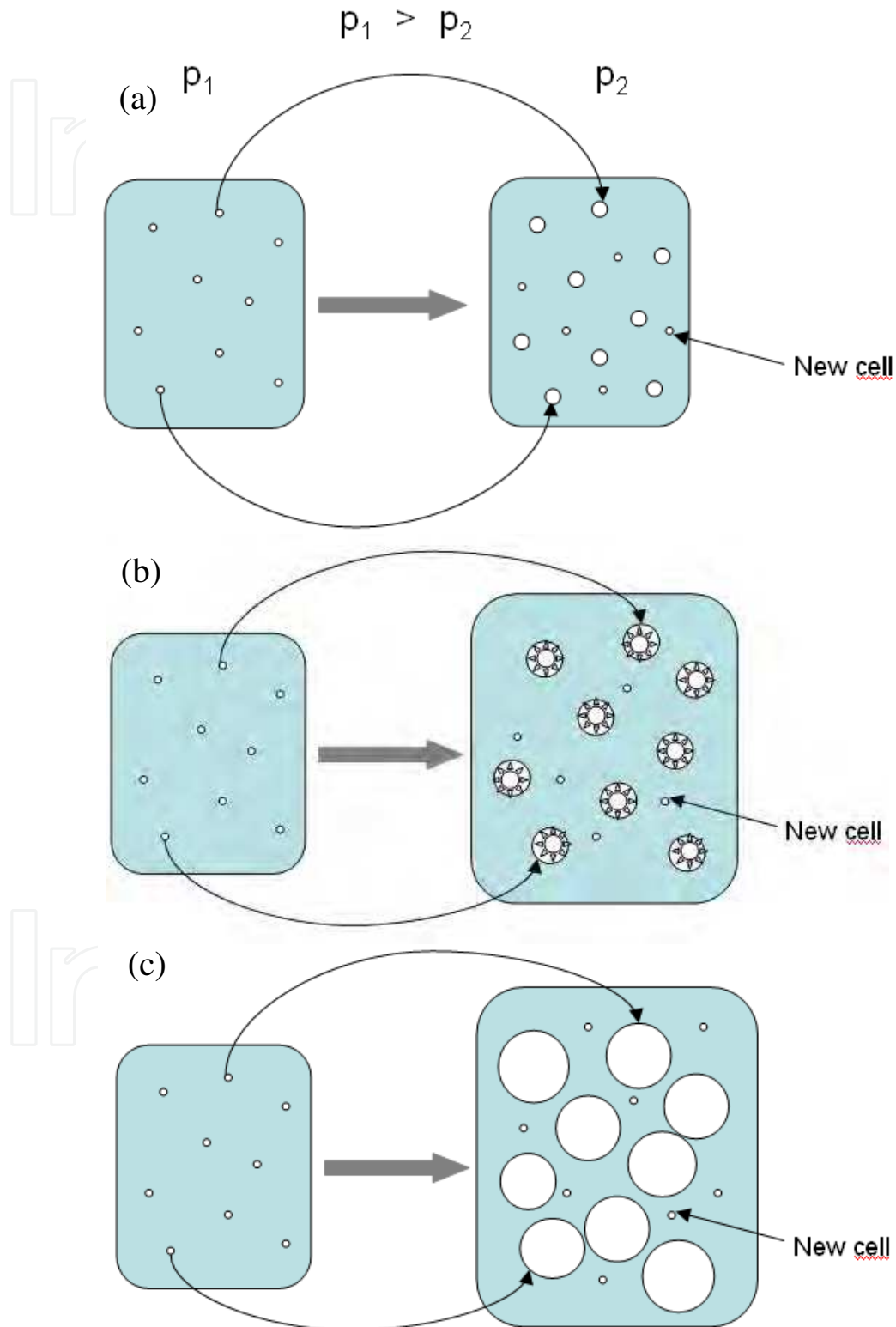

Fig. 16. Schematic representation of extrusion foaming stages

The most important stages of the foaming process (e.g. cell nucleation and growth) have been presented schematically in Fig. 16.

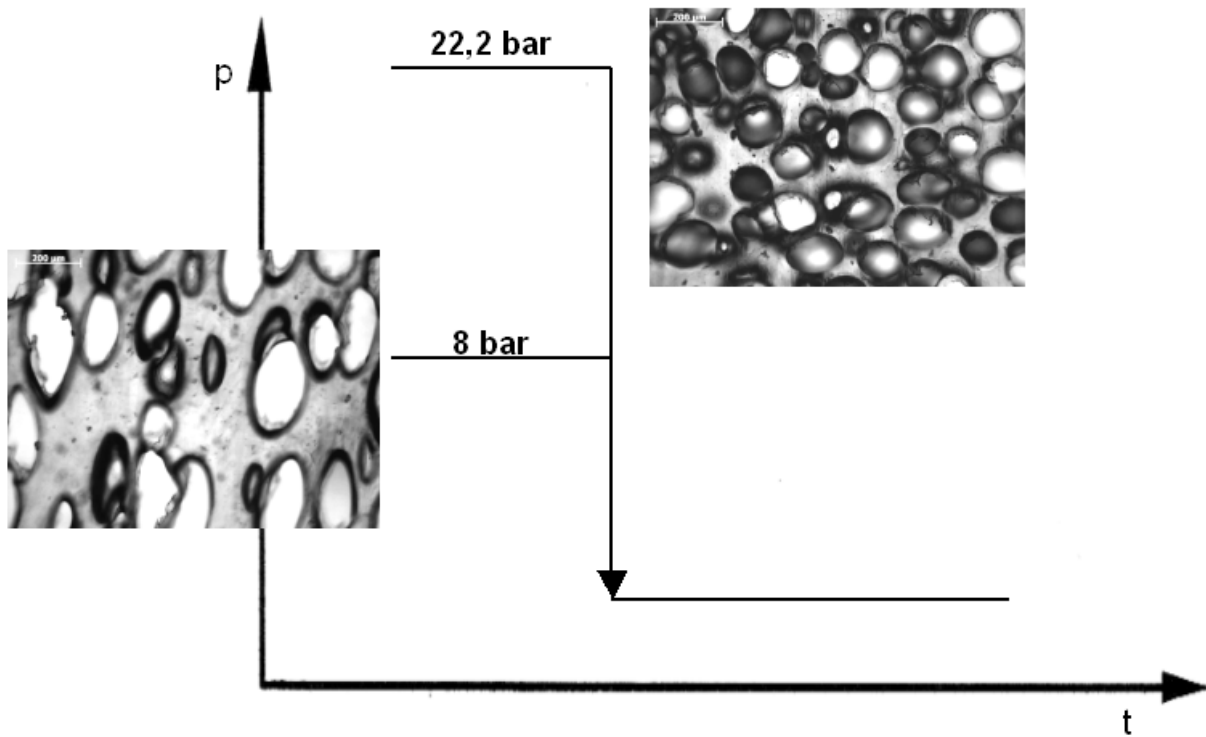

Fig. 17. Cell size and amount in LDPE foamed at different melt pressure

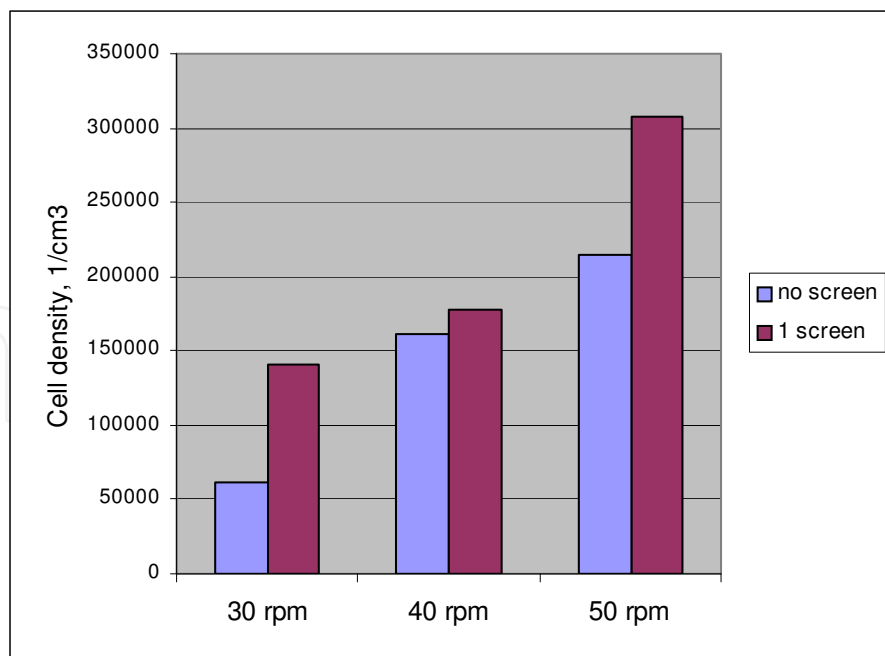

Fig. 18. Cell density in LDPE foam at different processing parameters

Critical factor for foaming is the cell nucleation rate, which is related to a change in the thermodynamic state of a system and phase separation. The gas dissolved formerly in a

molten polymer is evolving simultaneously at several sites of the material (a). Since the nucleation rate is much higher than the diffusion rate, the cell nuclei arise first, and only after some time they start growing due to a diffusion of next gas particles which appear as the gas solubility in a polymer melt falls due to the pressure and temperature decrease in a material after it exits the extrusion die.

Number of cells nucleated in the polymer depend on the pressure difference in the melt and atmospheric pressure. High difference developed by a change in the processing parameters or equipment configuration facilitates generation of higher cell density and their smaller size (Figs. 17 and 18).

Cell growth process (b) and (c) depends on several parameters, a.o. on the melt viscosity, melt strength and dynamics of cooling. For lower viscous melts the cells grow faster and are larger than these in a more viscous system (Fig. 19).

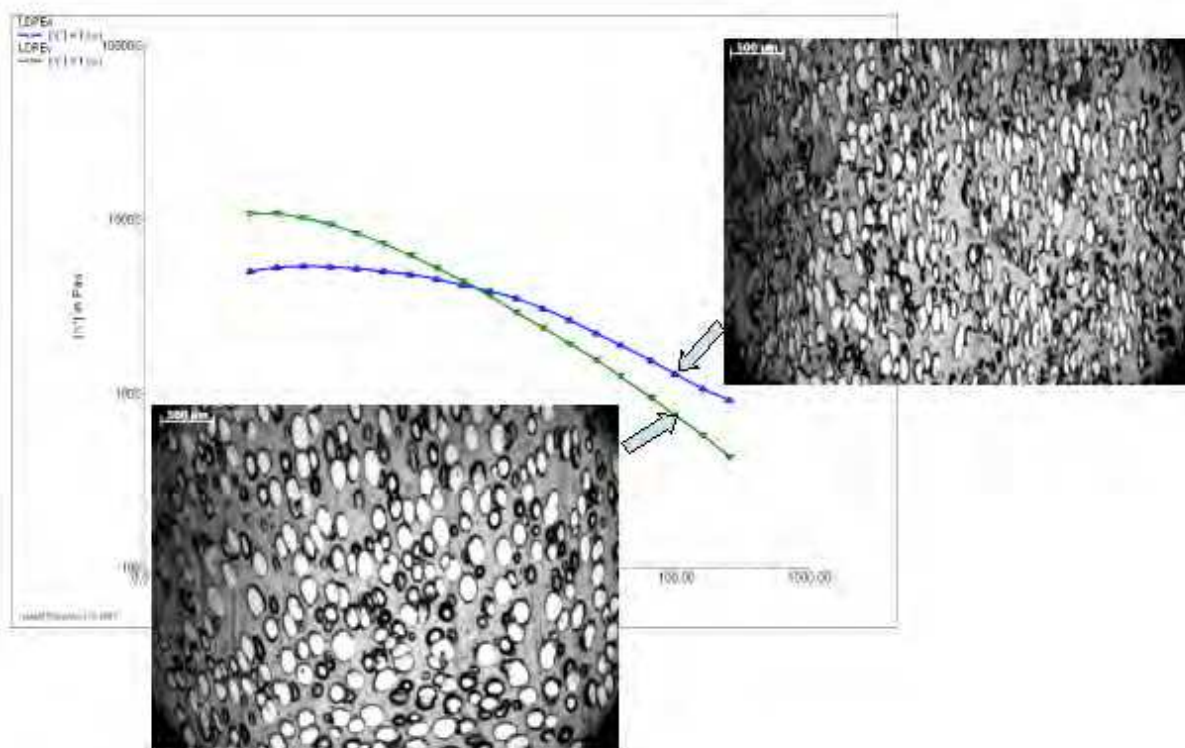

Fig. 19. Cell size and population for different LDPE grades (130°C)

One should consider that the gas dissolved in a polymer causes its plasticization, therefore the melt viscosity decreases markedly, thus modifying the foaming progress. In Fig. 20 a drop in the torque measured at kneading of the polymer melt after addition of an endothermic chemical blowing agent has been presented.

Total amount of cells and their size are related to the polymer melt strength. In case it is high the neighbouring cells may grow individually, however if it is low, the cell walls may disrupt due to an internal gas pressure and coalescence of cells occurs (Fig. 21). Another issue is a gas escape from the polymer melt to atmosphere and a resulting surface warpage.

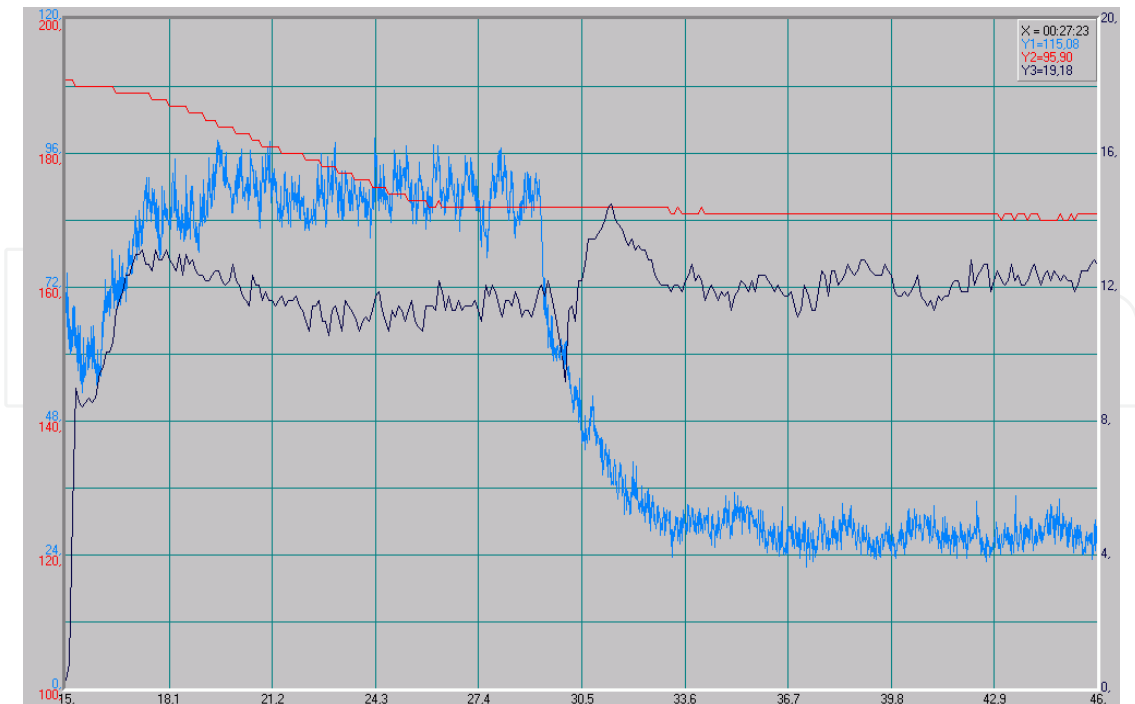

Fig. 20. Mixing torque and temperature change after addition of endothermic CBA to polymer

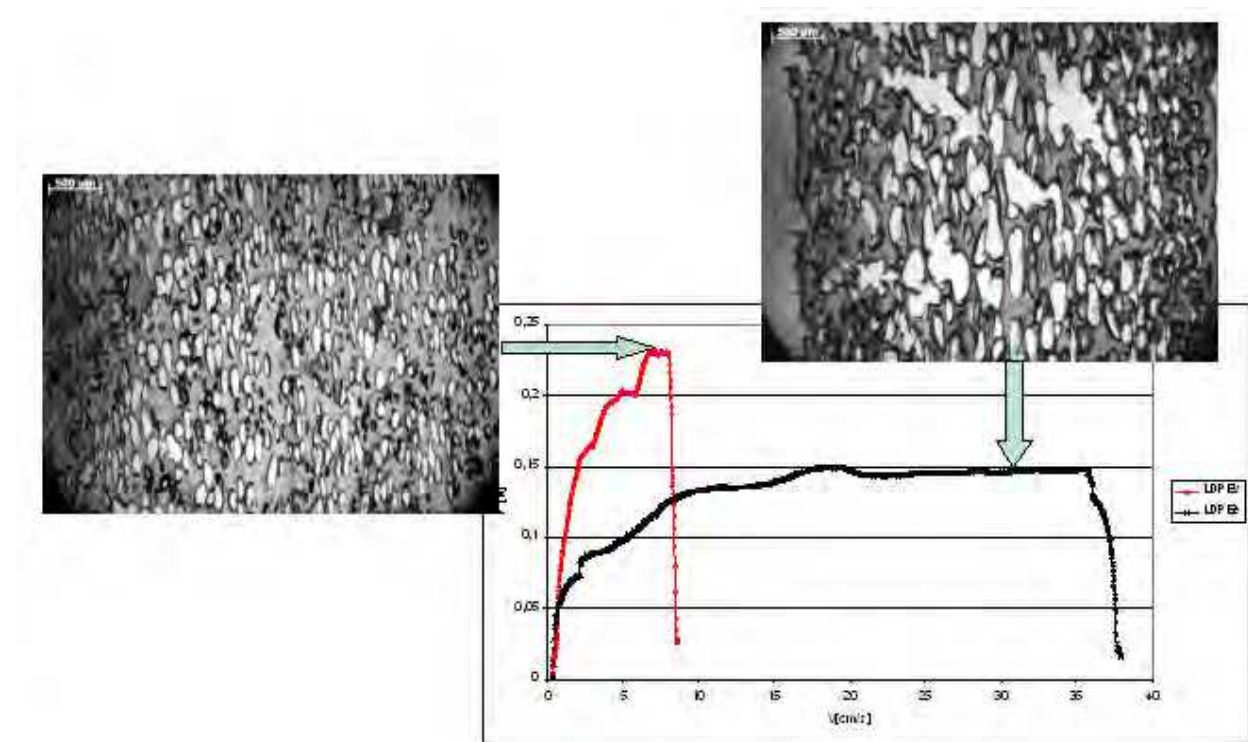

Fig. 21. Foam morphology generated in LDPE of different melt strength (130°C) – foam density 0.576 g/cm³ (left) and 0.447 g/cm³ (right)

The process of cell growth outlined in Fig. 16 stops as soon as the polymer glass temperature reaches the lower foaming limit. It may proceed fastly, because T_g increases with decreasing

concentration of a gas in the polymer. At that stage a cooling dynamics is essential for the foam morphology (Fig. 22). Provided the cooling is fast in the cooled calibrator, cells remain at the size generated shortly after exiting a die. However, if cooling proceeds slowly, the cells continue growing until the material solidifies by heat exchange with the ambient atmosphere.

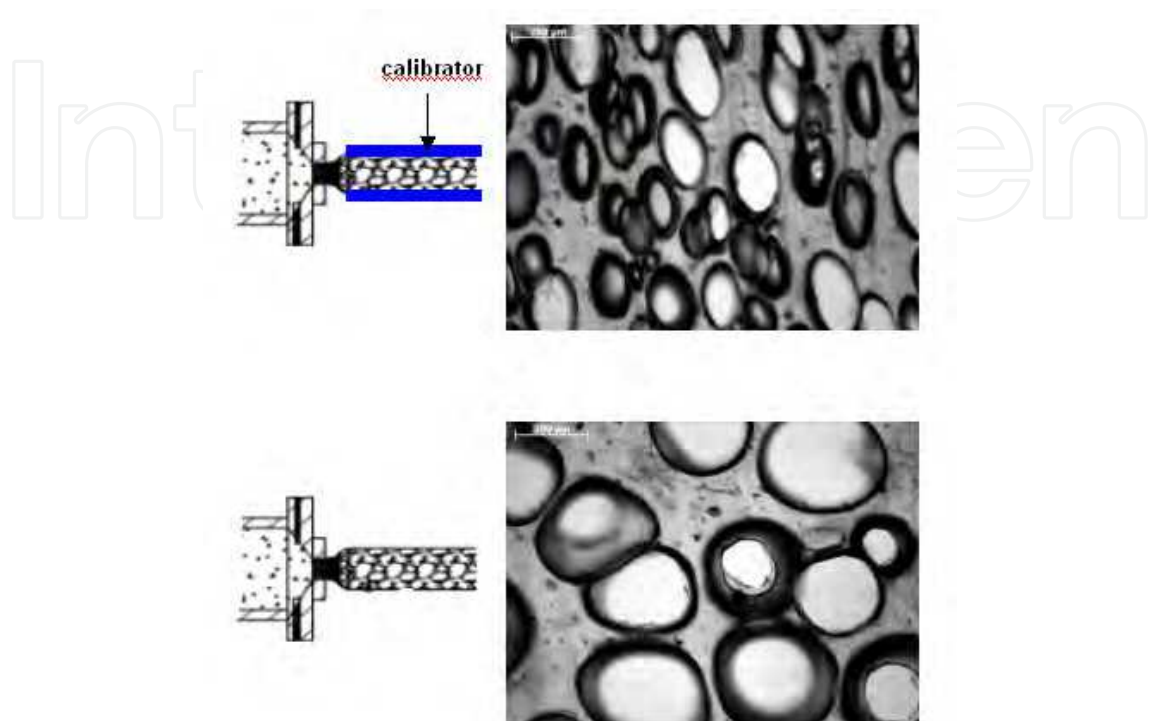

Fig. 22. LDPE foam morphology after cooling in calibrator and cooled freely (bottom)

Research on extrusion microfoaming of polystyrene with supercritical carbon dioxide has shown high influence of the extrusion die temperature and the dynamics of cooling on the resulting foam density and structure. The foaming level amounted to 15-25% (Sauceau et al., 2007).

Extruded microfoams have small cell size and exhibit low cell size distribution (Fig. 23).

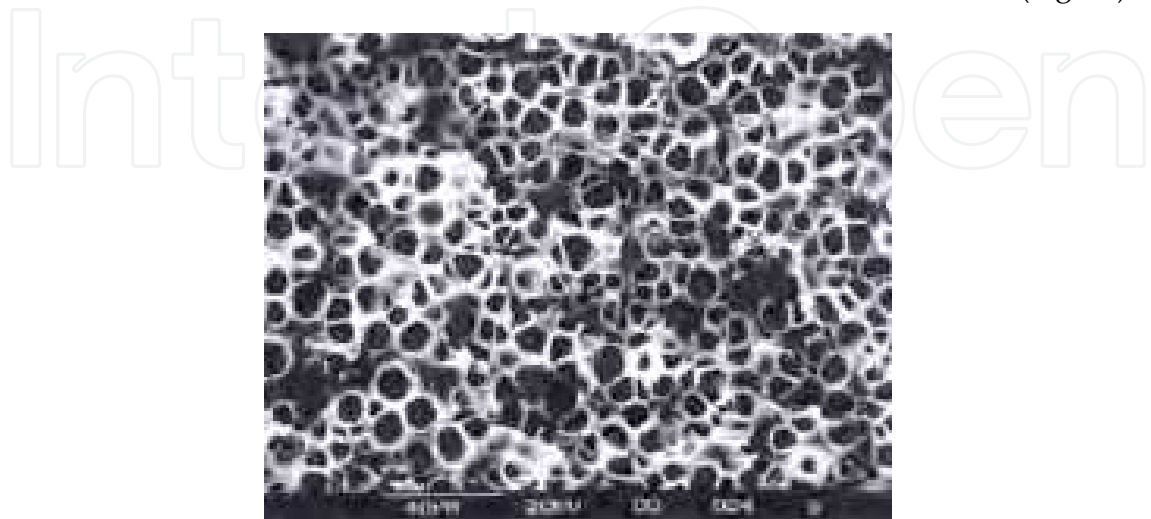

Fig. 23. Structure of microfoam manufactured by extrusion foaming (Park, 2000)

Cell size depend on the pressure within the cells, the melt strength and interfacial tension. The higher is the pressure, the smaller is the melt strength and interfacial tension, the larger cells are generated. As the cell grow and they wall thickness decreases, the coalescence probability of neighbouring cells increases. Behraves at al. (1998) have found that a coalescence is facilitated with a high shear stress during processing, however its probability decreases with lower melt temperature. Therefore cooling of the gas-polymer solution in a heat exchanger or within a die is advantageous.

Polymer foaming may be performed with single screw extruders of high L/D ratio equipped with mixing elements at a last section of the screw, or with the twin screw or tandem extruders. In any case very important is a precise dosing of a gas, since its surplus causes large cells formation.

In a tandem system (Fig. 24) the first extruder serves for polymer melting and mixing it with the injected gas. In the second extruder further homogenisation of the temperature and gas distribution within a polymer melt should be performed.

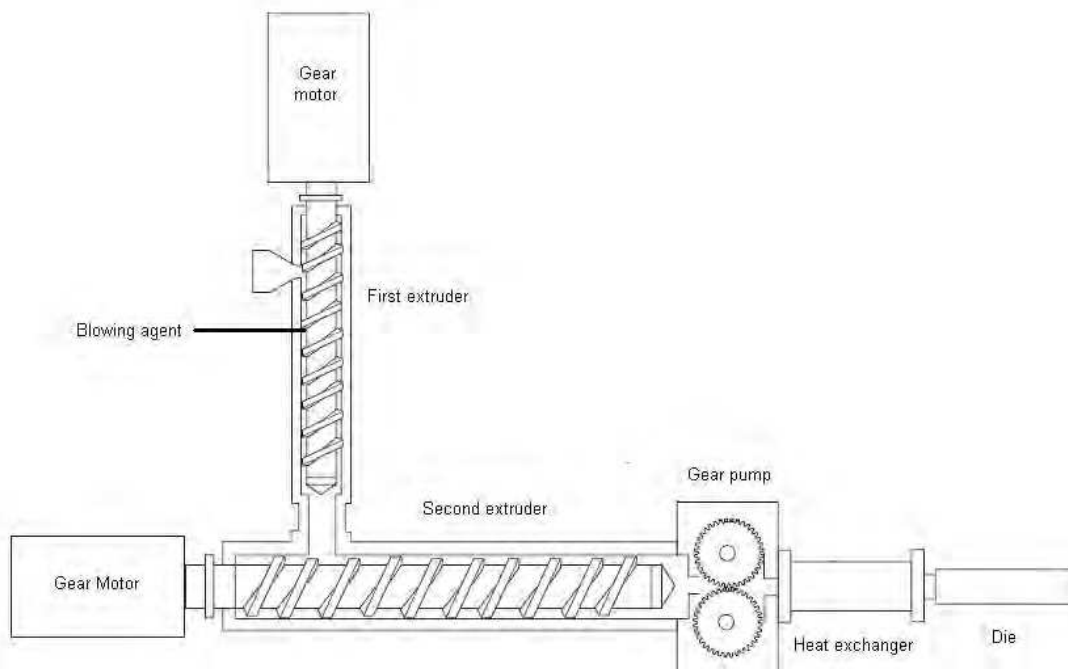

Fig. 24. Tandem extruder system for foaming (acc. to Lee & Park, 2006)

Proper design of every detail of the extrusion foaming set, the processing parameters and composition of the foamed material are crucial factors for the final morphology of a foam. The die geometry is of high importance, because the cell nucleation takes place there. Extensive discussion of the die role for generation of a high cell density has been presented by Xu et al. (2003) at the example of PS foaming with carbon dioxide.

Pressure in a die depends on the temperature and shear forces in the molten polymer. Provided the die temperature is high, the melt viscosity is low, which causes a low pressure drop in the melt after it exits the die and a low number of nuclei. However, at the low die temperature the melt pressure becomes high and the cell density is also high.

Shear stress level in the melt also influences pressure in the die. High pressure is beneficial to the cell density, however its too high level may cause the melt instabilities and cells rupture.

The nuclei number in a foamed polymer melt may be increased by means of fillers addition (Antunes et al., 2009; Khorasani et al., 2010). Foaming of polypropylene with carbon dioxide and addition of talc has shown that the cell density depends on both the filler and foaming agent content, however the nucleating effect of talc was observed only at low talc loading. Similarly, the positive effect of talc on the cell nucleation process and total cell density has been noted at foaming of PP with isopentane. It has been concluded that the nucleation mechanism depends on a size of the gas particles used for foaming. Recently also nanofillers have been reported as efficient cell nucleants for PP and HDPE foams (Khorasani et al., 2010).

Interesting properties exhibit cellular plastics manufactured from polymer blends. Basing on a knowledge on polymer melt rheology and blends morphology one can generate bi-modal distribution of cells located in different polymer domains. That idea has been presented for PPE/SAN blend foaming with carbon dioxide (Ruckdaeschel et al., 2007).

Another modification of foaming technology presents mixing of polymer with CBA, partial crosslinking of the polymer and than decomposition of the blowing agent with evolution of a gas. Cell structure can be limited by means of the crosslinking level, thus microfoams can be manufactured with such technology (Rodriguez-Perez et al., 2008). Microcellular polyethylene is used a.o. for pipe insulations, gaskets and in a healthcare as the wound dressing or sensitive skin protection.

4. Foaming devices

Extensive research on polymer foaming which was performed at MIT, Massachusetts (USA) received commercialisation of obtained results. For that purpose Trexel Inc. company was established, which has developed MuCell® technology of microfoams manufacturing by means of a supercritical gas [9]. Its main advantage is low consumption of polymer, high mechanical properties (including the impact strength), good thermoinsulating properties, as well as high surface quality of manufactured details. Such characteristics have been received due to the low cell size (5 - 50 µm), their regular shape and high cell density (10^8 cells/cm³).

Applying MuCell® technology for injection molding requires mounting the gas injector in a proper place of the cylinder (Fig. 25), selecting a screw geometry enabling thorough mixing of a gas with molten polymer and adjusting the gas injection with the overall injection cycle time. Decompression of the gas-melt solution should take place just in a mould. MuCell® allows for a shorter cycle time (15-35%), lower density of details (6-12%), reduction of internal stresses and high dimension stability.

While applying MuCell® technology for extrusion foaming one should consider also the gas injector, proper screw design and well selected die geometry. Proper matching of all parameters should result in a high pressure in the melt, which is crucial for efficient foaming. Foaming extrusion by MuCell® allows a.o. manufacturing HDPE pipes with cell size of 15 µm and material density of 0,54 g/cm³, EPDM gaskets for automotive applications etc.

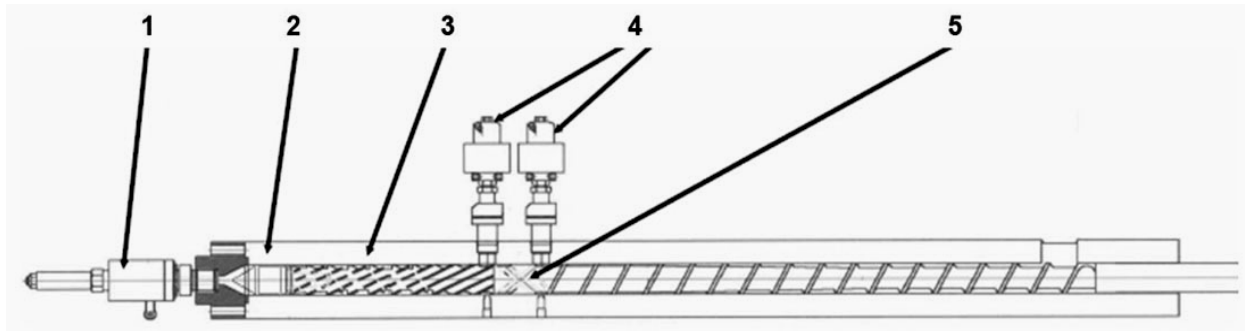

Fig. 25. Gas injection system in MuCell® technology (acc. to www.trexel.com)

1. die closure
2. control ring
3. screw mixing section
4. gas injector
5. valves

Another technology of cellular profiles extrusion offers Sulzer Chemtech (Switzerland). Optifoam™ technology anticipates a gas injector between the screw and extruder head (www.sulzerchemtech.com). Gas (CO_2 or N_2) is injected into the gas melt through a fluid injection nozzle made of sintered metal. The mixture of a gas and a polymer is next thoroughly homogenized in the static mixer section (Fig. 26).

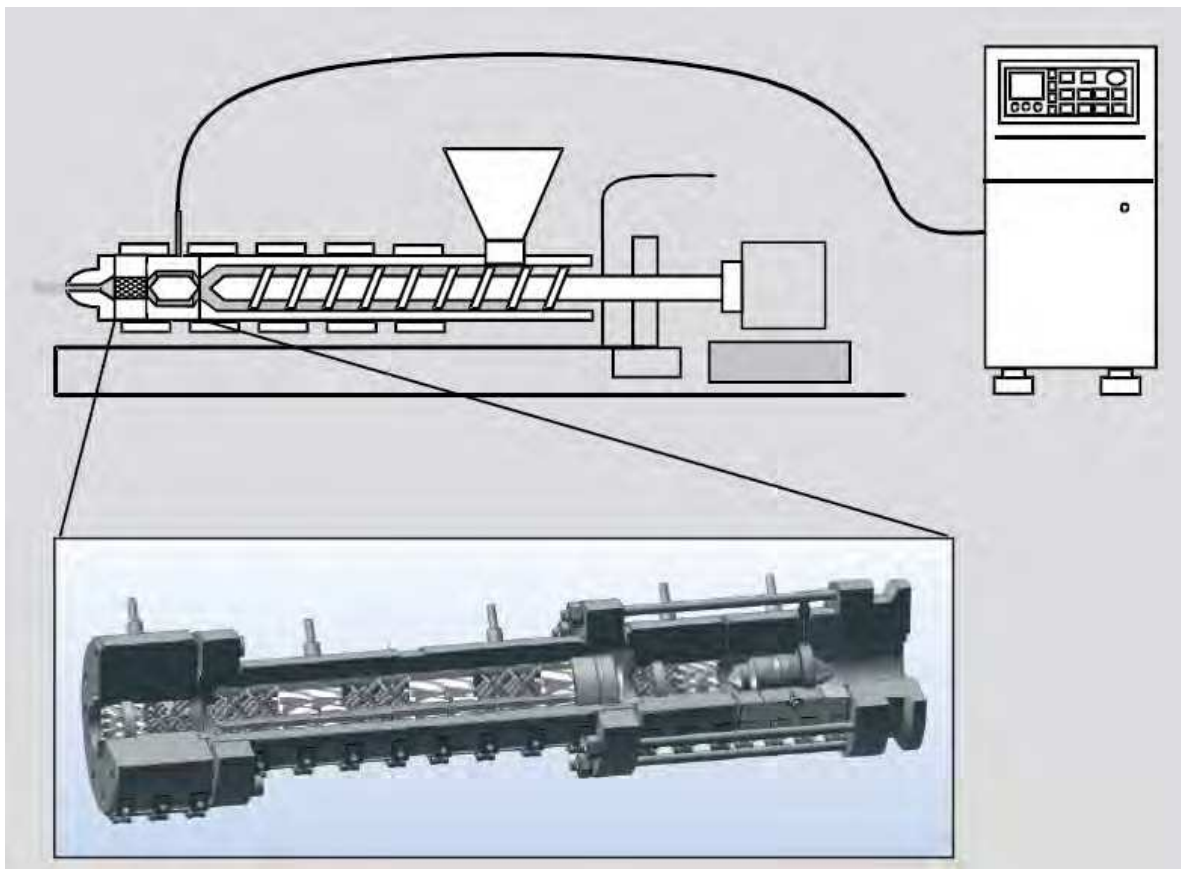

Fig. 26. Extrusion foaming set for Optifoam™ technology (www.sulzerchemtech.com)

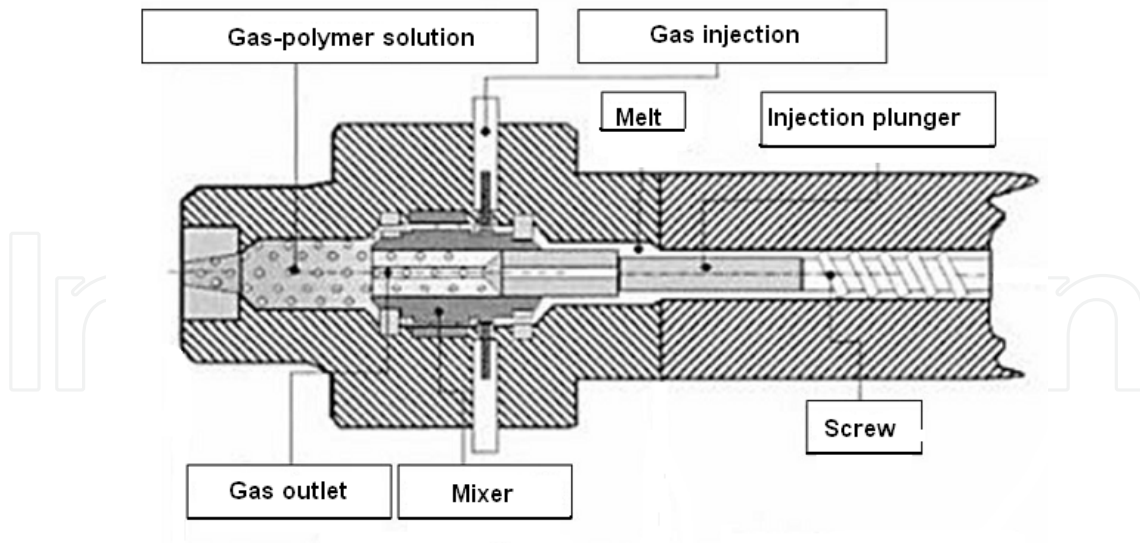

Fig. 27. Mixing unit of the ErgoCell® foaming injection molding (Sauthof, 2003)

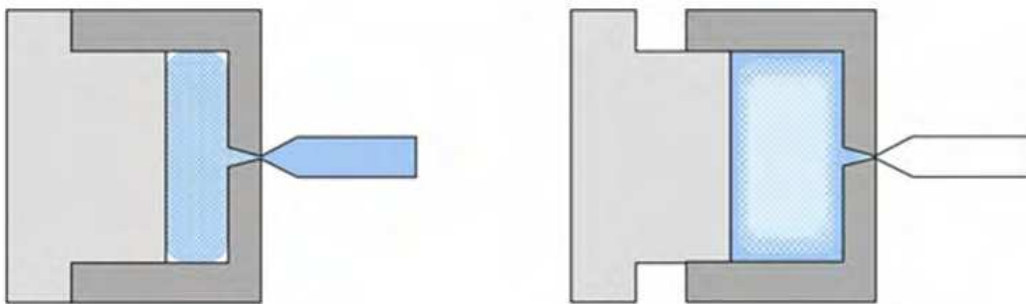

Fig. 28. Core Back Expansion Molding principle (www.mazda.com)



Fig. 29. Mazda2 door panel by Core Back Expansion Molding ((www.mazda.com)

ErgoCell® foaming technology developed by Demag Ergotech GmbH (Mapleston, 2002) assumes two stage process, with injection of a gas into mixing device located between the stationary screw and a melt accumulator equipped with an injection plunger (Fig. 27). ErgoCell® allows for a shorter cycle time, lower weight details (6-25%), reduction of internal stresses and surface defects.

Car manufacturer Mazda also applied solution of the supercritical gas (CO_2 or N_2) in the polymer melt. According to the Core Back Expansion Molding technology the material is injected into a mold and once the foamed polymer has filled up the mould, its volume is increased by moving the back of the mould (Fig. 28). Weight of the door panel for Mazda2 (Fig. 29) made with such technology is lower for 20%, while its stiffness is for 16% higher.

5. Foaming of biocomposites

Biocomposites used in the construction and automotive sector are frequently called „artificial wood” because their many properties and appearance are like wood (Matuana et al., 1998; Migneault et al., 2008; Bledzki et al., 2008). Unfortunately, the density of biocomposites, even if markedly lower than that of glass fiber reinforced composites, is still twice as high as the natural wood density. That drawback can be reduced by foaming of biocomposites that are lighter and feel more like real wood (Rodrigue et al., 2006; Guo et al., 2004, Bledzki & Faruk, 2006, Kozlowski et al., 2010). The earliest known foamed and wood-filled thermoplastics were based on polystyrene (PS) - this amorphous polymer is a perfect bubble catcher. Wood flour itself has been proved as an efficient nucleating filler in polyethylene foamed with azodicarbonamide (Rodrigue et al. 2006). As far as length of natural fibers is concerned, short fibers (75-125 μm) are favorable for foaming, since they do not disturb the cell growth process, like do the long fibers (4-25 mm).



Fig. 30. Cross section of foamed PP filled with 30 wt.% of wood flour - injection molded (left) and extruded profile (right)

Selection of the polymer matrix is very important for properties of biocomposites. Because cellulose fibers are polar, the hydrophobic matrices (like polyolefines) need addition of adhesion promoters in order to facilitate regular fiber distribution and efficient stress transfer across the composite during deformation in a molten state and during/after solidification.

Cellular biocomposites can be manufactured both by the extrusion or injection molding technology, however the extrusion foaming provides better results (Fig. 30), as it allows for a more precise process control.

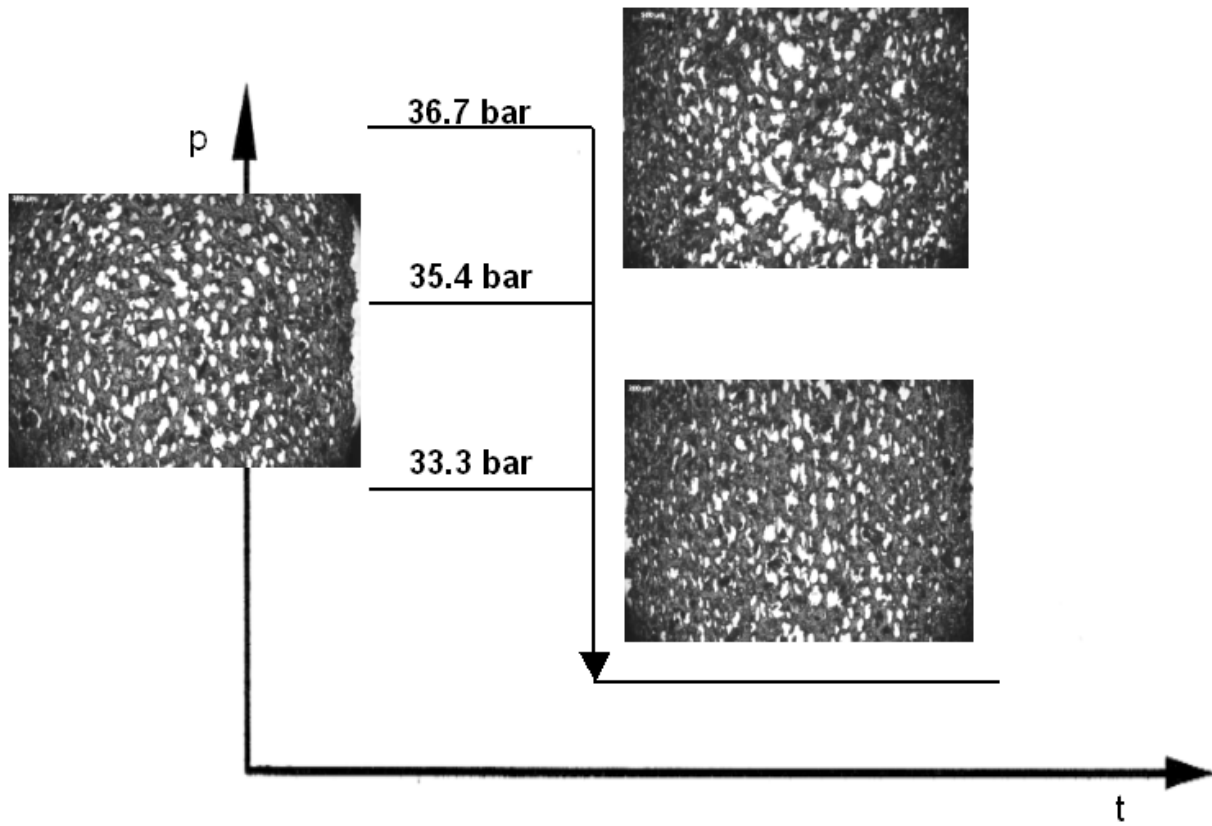

Fig. 31. Dependence of foam morphology on melt pressure for LDPE/wood flour composite

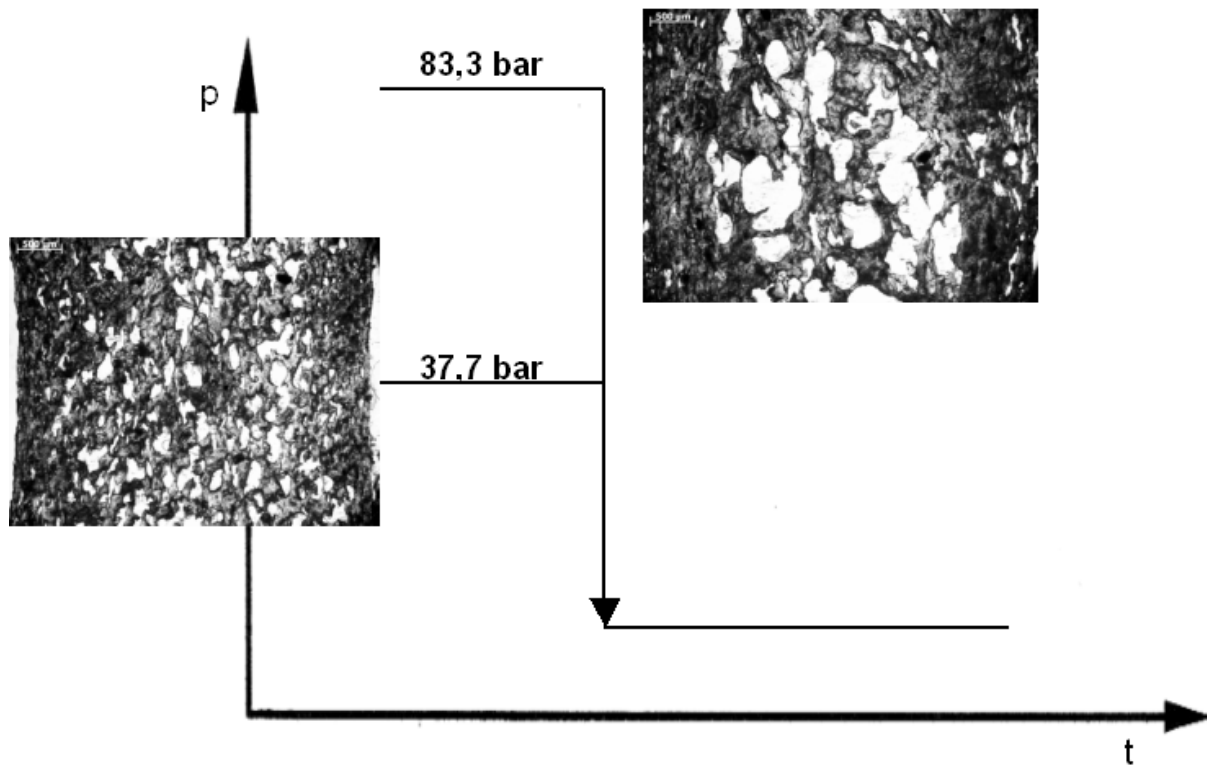

Fig. 32. Dependence of foam morphology on melt pressure for PP/wood flour composite

The study on foaming of biocomposites confirmed the findings formulated for non-filled polymers. High drop in the melt pressure between that in a die and ambient is favourable for manufacturing foams of fine, regular cells (Fig. 31), however if it is too high, that causes a cell damage and foam collapse (Fig. 32).

In general foaming is more difficult due to the high melt viscosity of biocomposites and low melt strength, however the results of research reported in recent years for foaming of wood composites with the chemical or physical blowing agents are promising. The technology of extrusion foaming seems to be fully controlled and the profiles manufactured looks like wood outside (Fig. 33) and in a cross-section (Fig. 34). The possibility of foaming composites filled with cellulose fibers make them ideal candidates for the low weight and thermal insulating engineering materials in all transport modes (Fig. 35).



Fig. 33. Extrusion foaming of PP filled with 30 wt.% of wood flour

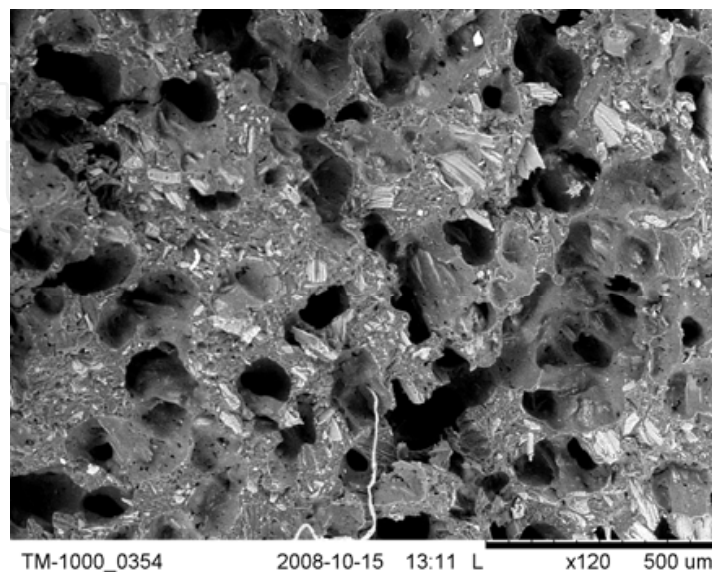

Fig. 34. Cross-section of PP/woof flour composite

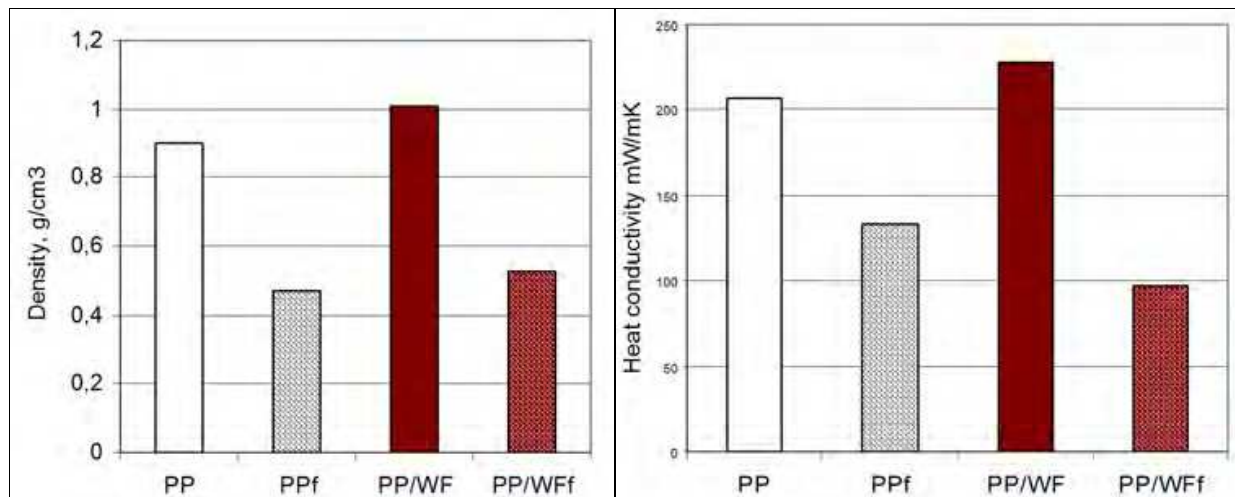

Fig. 35. Properties of PP, PP biocomposite and their foams

6. Acknowledgements

This work has been sponsored by the Polish structural grants POIG.01.03.01-00-018/08-00 under the Innovative Economy scheme. The Author wish to thank Dr. A. Kozłowska and Dr. S. Frackowiak for their valuable help in selected measurements.

7. References

- Antunes, M.; Velasco, J.I.; Realinho, V. & Solorzano E. (2009). Study of the cellular structure heterogeneity and anisotropy of polypropylene and polypropylene nanocomposite foams. *Polymer Engineering and Science*. Vol.49, No.12, pp. 2400-2413, ISSN 1548-2634
- Arora, K. A.; Lesser, A. J. & McCarthy, T. J. (1998). Preparation and Characterization of Microcellular Polystyrene Foams Processed in Supercritical Carbon Dioxide. *Macromolecules*, Vol.31, No.14, pp. 4614-4620, ISSN 0024-9297
- Behravesh, A. H.; Park, C. B. & Venter R. D. (1998). Approach to the Production of Low-Density, Microcellular Foams In Extrusion. *Proceedings of ANTEC'98*, pp. 1958-1967, ISBN 1566766699, Atlanta, USA, April 26-30, 1998
- Bledzki A. K., Faruk O., (2006). Microcellular injection molded wood fiber-PP composites: Part II - Effect of wood fiber length and content on cell morphology and physico-mechanical properties. *Journal of Cellular Plastics*, Vol.42, No.1, pp. 77-88, ISSN 1530-7999
- Bledzki, A. K.; Faruk O. & Mamun A. A. (2008). Influence of compounding processes and fibre length on the mechanical properties of abaca fibre-polypropylene composites. *Polimery*, Vol.53, No.2, pp. 120-125, ISSN 0032-2725
- Bieliński, M. (2004). *Techniki porowania tworzyw termoplastycznych*, Wydawnictwo Uczelniane ATR, ISBN 83-89334-86-0, Bydgoszcz, Poland
- Chen, X.; Feng J. J. & Bertelo C. A. (2006). Plasticization effect on bubble growth during polymer foaming. *Polymer Engineering and Science*. Vol.46, No.1, pp. 97-107, ISSN 1548-2634
- Cooper, A. I. (2000). Synthesis and processing of polymers using supercritical carbon dioxide. *Journal of Materials Chemistry*, Vol.10, No.2, pp. 207-234, ISSN 0959-9428

- Ellison, G. C.; McNaught, R. & Eddleston E. P. (2004). *The use of natural fibres in nonwoven structures for applications as automotive component substrates*, R&D Report NF0309, Ministry of Agriculture Fisheries and Food, London, United Kingdom
- Guo, G.; Rizvi, G. M.; Park, C. B. & Lin, W. S. (2004). Critical Processing Temperature in Manufacture of Fine-Celled Plastic/Wood-fiber Composite Foams. *Journal of Applied Polymer Science*. Vol.91, No.1, pp. 621-629, ISSN 0021-8995
<http://www.adeka-palmarole.com>
http://www.akzonobel.com/expancel/application_areas/benefits/porous_structure/index.aspx
<http://www.azflex.pl/izolacje/producent/armacell.php>
<http://www.cinpres.net/index.php/cinpres-technologies/igm>
<http://www.mazda.com/mazdaspirit/env/engine/mold.html>
<http://www.specialchem4polymers.com/resources/articles>
http://www.sulzerchemtech.com/en/portaldata/11/Resources//brochures/mrt/Optifoam_e.pdf
<http://www.trexel.com/injection-molding-solutions/index.php>
- Huang, H.-X.; Wang, J.-K. & Sun, X.-H. (2008). Improving of Cell Structure of Microcellular Foams Based on Polypropylene/High-density Polyethylene Blends. *Journal of Cellular Plastics*, Vol.44, No.1, pp. 69-85, ISSN 1530-7999
- Institute of Materials, Minerals and Mining. (2004). Lightweight Plastic Panels Manufactured from Recycled Plastics - Panels for Commercial Vehicles. *Materials World*, Vol. 12, No. 6, pp. 25-27, ISSN: 0967-8638
- Khorasani, M. M.; Ghaffarian, S. R.; Babaie, A. & Mohammadi N. (2010). Foaming Behavior and Cellular Structure of Microcellular HDPE Nanocomposites Prepared by a High Temperature Process. *Journal of Cellular Plastics*, Vol.46, No.2, pp. 173-190, ISSN 1530-7999
- Klesov, A. A. (2007). *Wood-plastic composites*, Wiley, ISBN 978-0470148914, Hoboken, USA
- Kozłowski M. & Kozłowska, A. (2005). Biocomposites from waste plastics, *Proceedings of Global Plastics Environmental Conference 2005*, Atlanta, USA, February 23-25, 2005
- Kozłowski, M.; Kozłowska, A. & Frąckowiak, S. (2010). Materiały polimerowe o strukturze komórkowej. *Polimery*. Vol.55, No.10, pp. 726-739, ISSN 0032-2725
- Lee, J. W. S. & Park C. B. (2006). Use of Nitrogen as a Blowing Agent for the Production of Fine-Celled High-Density Polyethylene Foams. *Macromolecular Materials and Engineering*. Vol.291, No.10, pp. 1233-1244, ISSN 1438-7492
- Lee S.T. (2000). Foam Nucleation in Gas-Dispersed Polymeric Systems, In: *Foam Extrusion. Principles and Practice*, Lee, S.T. (Ed.), CRC Press, Boca Raton, USA
- Lee, S. T.; Park, C. B. & Ramesh, N.S. (Eds.). (2006). *Polymeric Foams: Science and Technology*, CRC Press, Boca Raton, USA
- Li, G.; Wang, J.; Park, C.B. & Simha R. (2007). Measurement of Gas Solubility in Linear/Branched PP Melts. *Journal of Polymer Science Part B-Polymer Physics*. Vol.45, No. 17, pp. 2497-2508, ISSN 0887-6266
- Mapleston, P. (2002). *Modern Plastics Worldwide*, November, p.31, ISSN 0026-8275
- Matuana, L. M.; Park, C. B. & Balatinez J. J. (1998). Cell Morphology and Property Relationships of Microcellular Foamed PVC/Wood-Fiber Composites. *Polymer Engineering and Science*. Vol.38, No.11, pp. 1862-1872, ISSN 1548-2634

- Migneault, S.; Koubaa, A.; Erchiqui, F.; Chaala, A.; Englund, K.; Krause, C. & Wolcott M. (2008). Effect of fiber length on processing and properties of extruded wood-fiber/HDPE composites. *Journal of Applied Polymer Science*. Vol.110, No.2, pp. 1085-1092, ISSN 0021-8995
- Mooney, D.J.; Baldwin, D.F.; Suh, N.P.; Vacanti, J.P. & Langer, R. (1996). Novel approach to fabricate porous sponges of poly(D,L-lactic-co-glycolic acid) without the use of organic solvents. *Biomaterials*. Vol.17, No.14, pp. 1417-1422, ISSN 0142-9612
- Oksman Niska, K. & Sain, M. (Eds.). (2008). *Wood-polymers Composites*, CRC Press, ISBN 978-1-4200-7611-0, Boca Raton
- Park, C. B. (2000). Continuous Production of High-Density and Low-Density Microcellular Plastics, In: *Extrusion w Foam Extrusion. Principles and Practice*, Lee S.-T. (Ed.), CRC Press, Boca Raton, USA
- Rachtanpun, P.; Selke, S. E. M. & Matuana L. M. (2004). Effect of the high-density polyethylene melt index on the microcellular foaming of high-density polyethylene/polypropylene blends. *Journal of Applied Polymer Science*, Vol.93, No.1, pp. 364-371, ISSN 0021-8995
- Rodrigue, D.; Souici, S. & Twite-Kabamba, E. (2006). Effect of wood powder on polymer foam nucleation. *Journal of Vinyl and Additive Technology*. Vol.12, No.1, pp. 19-24, ISSN 1548-0585
- Rodriguez-Perez M. A., Almanza O., Ruiz-Herrero J. L., de Saja J. A. (2008). The effect of processing on the structure and properties of crosslinked closed cell polyethylene foams. *Cellular Polymers*. Vol.27, No.3, pp. 179-200, ISSN 0262-4893
- Rosato, D. (April 2010). Progress in Sustainable Foam Blowing Agent Technology. Available from: SpecialChem - Apr. 19,2010
- Ruckdaeschel, H.; Altstaedt, V. & Mueller A.H. (2007). Foaming of polymer blends - chance and challenge. *Cellular Polymers*. Vol.26, No.6, pp. 367-380, ISSN 0262-4893
- Sauceau, M.; Nikitine, C.; Rodier, E. & Fages J. (2007). Effect of Supercritical Carbon Dioxide on Polystyrene Extrusion. *Journal of Supercritical Fluids*, Vol.43, No.2, pp. 367-373, ISSN 08968446
- Sauthof, R. (2003). Physical foaming with Ergocell. Proceedings of Blowing Agents and Foaming Processes, Munich 19-20 May, 2003, p. 91, paper 10
- Schellenberg, J. & Wallis, M. (2010). Dependence of Thermal Properties of Expandable Polystyrene Particle Foam on Cell Size and Density. *Journal of Cellular Plastics*, Vol.46, No.3, pp. 209-222, ISSN 1530-7999
- Su, F.-H. & Huang, H.-X. (2010). Rheology and melt strength of long chain branching polypropylene prepared by reactive extrusion with various peroxides. *Polymer Engineering and Science*. Vol.50, No.2, pp. 342-351, ISSN 1548-2634
- Xu, X.; Park, C.B.; Xu, D. & Pop-Iliev, R. (2003). Effects of Die Geometry on Cell Nucleation of PS Foams Blown with CO₂. *Polymer Engineering and Science*. Vol.43, No.7, pp. 1378-1390, ISSN 1548-2634

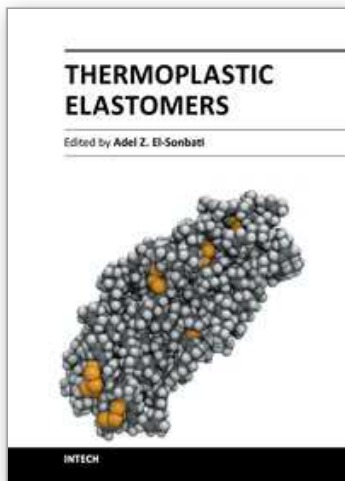

Thermoplastic Elastomers

Edited by Prof. Adel El-Sonbati

ISBN 978-953-51-0346-2

Hard cover, 416 pages

Publisher InTech

Published online 28, March, 2012

Published in print edition March, 2012

Thermoplastics can be used for various applications, which range from household articles to the aeronautic sector. This book, "Thermoplastic Elastomers", is comprised of nineteen chapters, written by specialized scientists dealing with physical and/or chemical modifications of thermoplastics and thermoplastic starch. Such studies will provide a great benefit to specialists in food, electric, telecommunication devices, and plastic industries. Each chapter provides a comprehensive introduction to a specific topic, with a survey of developments to date.

How to reference

In order to correctly reference this scholarly work, feel free to copy and paste the following:

Marek Kozlowski (2012). Lightweight Plastic Materials, Thermoplastic Elastomers, Prof. Adel El-Sonbati (Ed.), ISBN: 978-953-51-0346-2, InTech, Available from: <http://www.intechopen.com/books/thermoplastic-elastomers/lightweight-plastic-materials>

INTECH
open science | open minds

InTech Europe

University Campus STeP Ri
Slavka Krautzeka 83/A
51000 Rijeka, Croatia
Phone: +385 (51) 770 447
Fax: +385 (51) 686 166
www.intechopen.com

InTech China

Unit 405, Office Block, Hotel Equatorial Shanghai
No.65, Yan An Road (West), Shanghai, 200040, China
中国上海市延安西路65号上海国际贵都大饭店办公楼405单元
Phone: +86-21-62489820
Fax: +86-21-62489821

© 2012 The Author(s). Licensee IntechOpen. This is an open access article distributed under the terms of the [Creative Commons Attribution 3.0 License](#), which permits unrestricted use, distribution, and reproduction in any medium, provided the original work is properly cited.

IntechOpen

IntechOpen