

# We are IntechOpen, the world's leading publisher of Open Access books Built by scientists, for scientists

**4,800**

Open access books available

**122,000**

International authors and editors

**135M**

Downloads

Our authors are among the

**154**

Countries delivered to

**TOP 1%**

most cited scientists

**12.2%**

Contributors from top 500 universities



**WEB OF SCIENCE™**

Selection of our books indexed in the Book Citation Index  
in Web of Science™ Core Collection (BKCI)

Interested in publishing with us?  
Contact [book.department@intechopen.com](mailto:book.department@intechopen.com)

Numbers displayed above are based on latest data collected.

For more information visit [www.intechopen.com](http://www.intechopen.com)



# A Novel Method of Developing Frequency Encoded Different Optical Logic Processors Using Semiconductor Optical Amplifier

Sisir Kumar Garai

*Department of Physics, M.U.C. Women's College, Burdwan, West Bengal, India*

## 1. Introduction

To implement different digital processors in optical domain, encoding and decoding of optical data are the prime issues. Till now several encoding/decoding techniques have been reported for representing the optical information. In this connection spatial encoding [Toyohiko Y., 1986], intensity encoding [Mukhopadhyay S., et-al., 2004], polarization encoding [Awwal A.A.S., et-al., 1990; Zaghoul Y.A., et-al., 2006, 2011], phase encoding [Chakraborty B., et-al., 2009] etc. may be mentioned. But these coding processes have some inherent problems. In spatial encoding, two specific pixcells, each having two different types of opaque and transparent sub-cells distribution are encoded either as '1' and '0' states respectively in 2-D plane. Here input signal bits are generated by electro-optic/electronic switching (with suitable nonlinear materials) which limits the speed of processing. Again in pixels based operation, interference and diffraction effect may change the expected result of the image pattern at the output end which leads to bit error problem. Moreover, as output result is obtained using decoding mask, and the encoding and decoding technologies not being the same, therefore it is not possible to design sequential or combinational logic circuit using spatial encoding technique. In intensity encoding, presence of optical signal or the intensity of a signal greater than that of a specific reference intensity have been encoded as '1' state and absence of signal or the intensity of a signal lower than that of a specific reference intensity have been encoded as '0' state. But for long distance communication, intensity of optical signal may fall and dropdown below the reference level and for which the '1' state may be treated as '0' state of the signal which can also lead to the bit error problem. In most of the cases the all-optical logic gates are implemented by non-linear materials extending its 2<sup>nd</sup> order of nonlinearity. This material sends the light passing through it in different channels if the intensity of light varies. So the change of a prefixed value of intensity creates some major problems in channel selection and therefore this intensity based encoding principle is problematic. In intensity based refractive index variation technology, small fluctuation of intensity of the input beams may collapse the total set up. In polarization encoding, one specific state of polarization of the optical beam is encoded as '0' state and another specific orthogonal state of polarization is treated as '1'

state. Again, the state of polarization may change for several causes which can also lead to the bit error in information processing. In phase encoding, one specific phase of the optical beams is encoded as '0' state and another specific phase is treated as 1 state. But it is very difficult to maintain the constant phase relationship throughout the optical signal processing, specially, beyond the coherent length. Similarly the other coding norms may extend some other limitations in wide range data processing.

In contrast to the above mentioned encoding, the author has established the frequency encoded technique to represent the Boolean logic states. It is known that if '1' and '0' logic states are encoded by two different frequencies in optical domain, then one may ensure about the state of a signal during data transmission. If '0' state is encoded by the frequency ' $\nu_1$ ' and the '1' state by the other frequency ' $\nu_2$ ' then ' $\nu_1$ ' and ' $\nu_2$ ' will normally remain unaltered throughout the transmission of data. The frequency encoded technique offers so many advantages [Garai S.K., Mukhopadhyay S.(2009),2010; Garai S.K.(2010); Garai S.K.(2011),2011a,2011b]. The prime beauty of the frequency encoding is that, frequency is the fundamental property of the wave and it can preserve its identity irrespective of the absorption, reflection, transmission during its propagation throughout the communicating media. This is the most potential advantage of the frequency encoding technique over other conventional encoding techniques. In addition, frequency encoding in optical domain uses the spectrum of a broadband optical source and can accommodate a large pool of subscribers. Moreover different signals are characterized by different specific frequencies in optical domain and if one signal of specific frequency can be encoded to represent a specific state of information, then using different signals of different frequency, other different states can be encoded. Thus a larger number of states of information can be accommodated which can propagate through the same channel i.e., through the same optical fiber without interference or cross-talk. Again using frequency encoding it is easier to represent multi-bit states of information which are very useful for conducting multivalued logic operations using wavelength conversion properties of different high speed nonlinear optical switches such as semiconductor optical amplifier, periodically poled lithium niobate (LiNbO<sub>3</sub>) waveguide, Chalkogenide glass etc. Since the information is frequency encoded, therefore the coded signal is very useful for optical wavelength division multiplexing (WDM), frequency division multiplexing (FDM) and combination of WDM and time division multiplexing (TDM) in interconnection of telecommunication networks.

Basic building blocks required to implement the frequency encoded optical logic processors are the Frequency Router Unit (F.R.U) and Frequency Converter Unit (F.C.U) and SOA is found to be the very promising in this aspect. A rapid growth in the optical fibre communication was noticed over the last thirty years exploiting the enormous bandwidth property and many other characters of optical fibre. The massive advancement of optical technology has been made possible because of several reasons. In this regard it can be specially mentioned that Semiconductor Optical Amplifier (SOA) is a promising optical device that help a lot for the acceleration of advancing the network systems in communication. SOAs are highly nonlinear in an optical gain range. This is due to the consequence of a large number of free carriers confined in a small active region and it affects the gain as well as refractive index within the active region. The SOA nonlinear properties such as cross gain modulation (XGM), cross phase modulation (XPM), four-wave mixing (FWM) have been studied several times and are applied to implement wavelength conversion, optical division multiplexing-demultiplexing, clock recovery, and optical logic

gates [Connelly M.J.(2002); Dutta N.K. et.al.,2006, Asghari M.,et-al.,1997; Soto.H.,et.al.,1999; Guo L.Q., Connelly M.J.(2007) ]. The wavelength conversion by XGM is accompanied by large chirp and low extinction ratio with restricted speed (limited by the carrier recovery time) up to 40Gbit/s and even up to 100Gbit/ with some degradation. On the other hand the XPM schemes enable wavelength conversion with lower signal powers, reduced chirp, enhanced extinction ratios and ultra fast speed of switching. The wavelength conversion by FWM is very promising one due to its independent modulation format as well as dispersion compensation property with ultra speed. However, it has polarization sensitive low wavelength conversion efficiency. Wavelength conversion based on cross polarization modulation (XPoM) is another promising approach. In XPoM process, nonlinear polarization rotation (NPR), an optically induced birefringence and dichroism property of an SOA have been exploited for wavelength conversion and it has drawn the attention of scientists and technologists [Guo L.Q., Connelly M.J.(2005,2006); Lacey J.P.R., et.al.,1998]. Very recently all-optical wavelength (both up and down) conversion has realized exploiting non-linear properties of SOA [Guo L.Q., Connelly M.J.(2008)]. In this chapter the author has presented a novel method of developing all optical logic processor exploiting frequency conversion and switching character of SOA. The author has organized the chapter in brief based on his established works and actually it is a review one with some modifications.

The Chapter covers (a) a method of generating all-optical decimal data to frequency encoded binary data (b) a method of developing all optical frequency encoded binary logic gates such as AND, OR, NAND, NOR, EX-OR and finally (c) an all optical memory unit, and all of these are the integral part of the all-optical logic processors and these are developed exploiting different attractive features of SOA. The author has exploited here the principle of nonlinear rotation of the state of polarization (SOP) of the probe beam in semiconductor optical amplifier for the frequency conversion as well as for the switching purpose and this type of switching is so called polarization switching (PSW). The chapter is organized as follow: In section-2, the author has presented the basic principle of frequency conversion using nonlinear polarization rotation (NPR) of the probe beam in SOA, principle of channel (frequency) routing by optical add/drop multiplexer and the action of polarization switch made of SOA. Section-3 covers the method of all-optical decimal to frequency encoded binary data generation. Method of developing frequency encoded all-optical logic units are presented in section-4. An all optical binary memory unit is presented in section-5 and conclusion is drawn in section-6.

## **2. Some important functions of SOA as the elements of optical processor**

### **2.1 Frequency conversion exploiting Nonlinear Polarization Rotation (NPR) of the probe beam in SOA**

One of the important properties of SOA is non-linear polarization rotation of the probe beam due to optically induced nonlinear refractive index in a bulk SOA by highly intense pump beams [Guo L.Q., Connelly M.J.(2005),(2006),(2007); Dutta N.K. et.al.,2006, Liu Y., et.al.,2003, Fu S. et.al.,2007 ]. During the interaction of the intense pump beam with probe beam in nonlinear SOA, the intense pump beam can modify the optical properties of the SOA which, in turn modify the intensity of probe beam as well as its SOP. If a linearly polarized light is coupled in a SOA, after leaving the SOA its SOP will change. A polarization beam splitter (PBS) at the output end can detect the nonlinear polarization rotation in terms of intensity difference. The mechanism is explained below.

At first the SOA is to be biased with suitable current and also the power level of input pump beams 'A' and 'B' are to be adjusted properly. 'X' is the linearly polarized probe beam of frequency  $\nu$  but weak in intensity and, it is coupled with the pump beams in SOA. The scheme is shown in Fig.1(a).

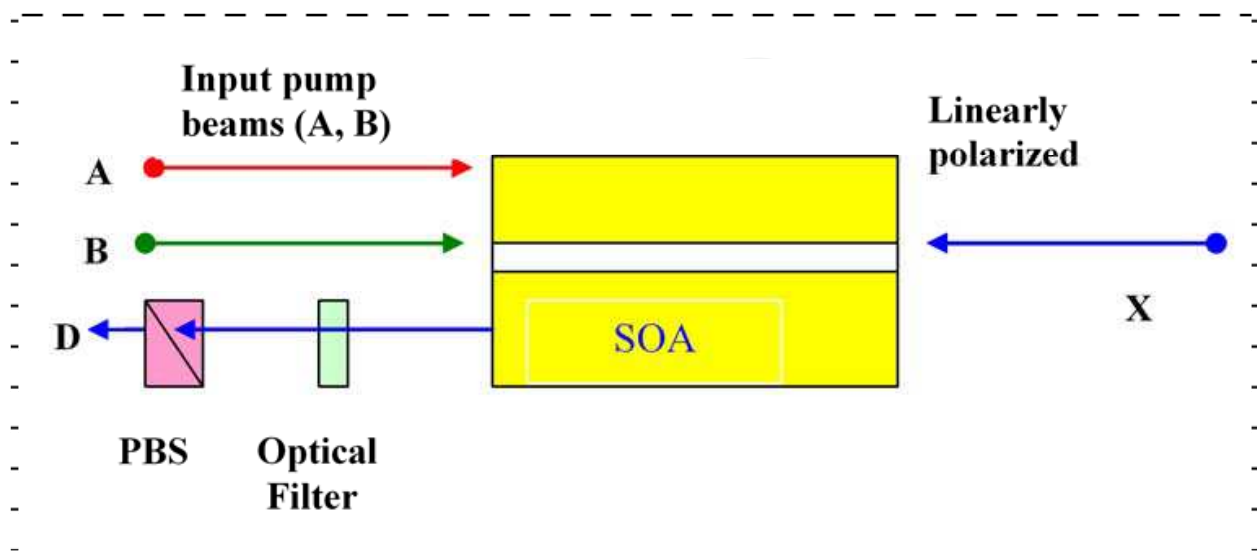

Fig. 1(a). Frequency conversion by SOP of probe beam

In the absence of both the input pump beams 'A' and 'B', the polarizer is adjusted in such a way that the pass axis of the polarization beam splitter (PBS) is crossed with respect to SOP of the linearly polarized probe beam(X). For this setting no light is obtained at output end (D). One input pump beam (A/B) alone does not change the SOP of the probe beam dramatically and no light will pass through the PBS. When both the input pump beams 'A', 'B' are present, the state of polarization of the probe beam will change drastically and as result a considerable amount of light of frequency  $\nu$  will pass through the PBS and will appear the output end 'D'. It is to be noted that only one pump beam of intensity equal to the sum of the intensity of both the pump beams A and B can also rotate the state of polarization of the probe beam in SOA and therefore with the help of the control beam (pump beam) of such intensity it is possible to transmit the probe beam from input end to output end of an SOA.

## 2.2 Function of an add/drop multiplexer

Input optical data signals may be of different frequencies and these data signals can be directed through separate paths using add/drop multiplexer (ADM) [Yu S., et.al.,2005; Jiang Y., et.al,2010]. The function of an 'ADM' is to separate a particular channel without interference from adjacent channels. This can be achieved by using an integrated 'SOA' with a tunable filter with it. The filter can be tuned at different frequencies by changing the bias current of SOA. The selected channel is reflected by the filter, amplified a second time by the Multi Quantum Well (MQW) section and extracted to a drop port by means of a circulator. The remaining channels pass through the filter section without any drop. In Fig.1(b) the frequency ' $\nu_2$ ' is extracted from incoming signals of frequencies  $\nu_1, \nu_2, \nu_3, \dots, \nu_N$  using drop multiplexer and also added to the next step by means of add multiplexer using another circulator.



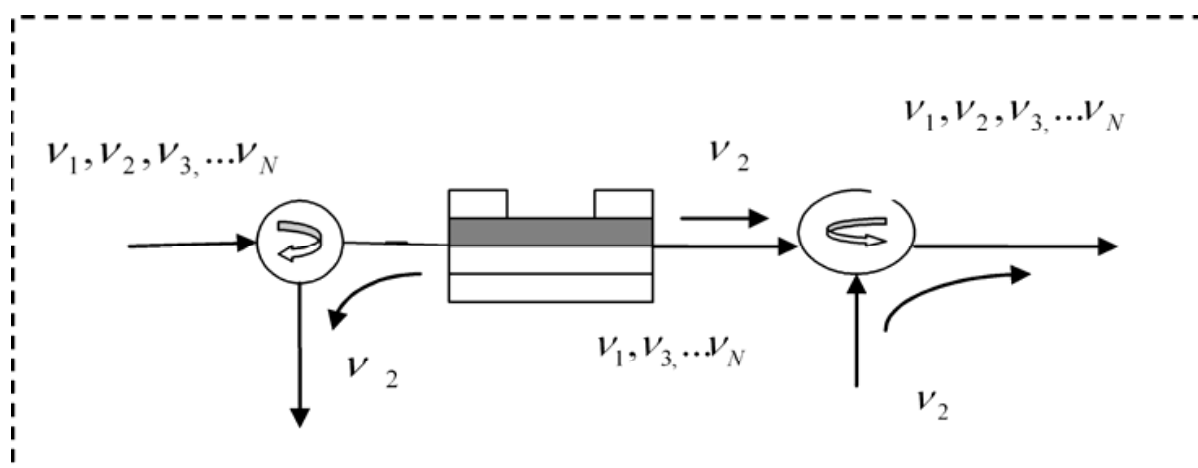

Fig. 1(b). SOA based add/drop multiplexer

### 2.3 Action of polarization-switch (PSW)

The principle of polarization SOA-gain saturation property may be exploited to design the nonlinear polarization switching (PSW) [Dorren H.J.S., et-al., 2003; Garai S.K., Mukhopadhyay S. (2010); Garai S.K., 2011a]. The scheme of the polarization switching is shown in Fig. 1(c). It consists of two laser sources having different frequencies, three polarization controllers, one strained bulk SOA, one polarization beam splitter (PBS), an attenuator and a power meter. The probe beam is a CW laser of frequency  $\nu_1$  whereas the pump laser beam is a highly intense beam of frequency  $\nu_2$ . The state of polarization of the probe beam, pump beam and output beam of SOA are controlled by polarization controllers PC1, PC2 and PC3 respectively. The probe beam is fed to one input terminal of SOA via an attenuator so that the input probe beam power injected to the SOA is very low ( $-15 \text{ dB}_m$ ) and it confirms the operation of SOA in the linear regime under the action of probe beam alone. The orientation of linearly polarized probe beam is adjusted by PC1 in such a way that the polarization direction of the input probe beam is approximately  $45^\circ$  to the orientation of SOA layer. The output beam of SOA is combined by means of polarization beam splitter (PBS). The PBS is used to split the SOA output into horizontal (H) and vertical polarization components (V). The vertical component of SOA output is obtained at port-1 and horizontal component at port-2.

In the absence of pump beam, the optical field of linearly polarized probe beam may be decomposed into a transverse electric field (TE) and transverse magnetic field (TM) components. These two modes propagate through SOA independently and amplify by the biasing current in SOA. The biasing current is set to such a value (162 mA) that the maximum gain is obtained for TE and TM modes which are almost equal. Under this situation the state of polarization of output beam of SOA is oriented in such a way by PC3 that the beam at the output port-1 becomes zero (it is measured by power meter) i.e. vertical component (V) of the output beam of SOA is absent and obviously maximum power is delivered at port-2.

SOA have the property of polarization dependent gain saturation. Therefore, in the presence of highly intense pump beam the polarization dependent gain saturation character gives rise to different refractive index change for TE and TM. Under gain saturation condition the output of port-2 will be a function of saturation-induced phase difference between two modes [Dorren H.J.S., et-al., 2003] given by

$$\varphi = \varphi^{TE} - \varphi^{TM} = \frac{1}{2} \left[ \frac{\alpha^{TE} \Gamma^{TE} g^{TE}}{v_g^{TE}} - \frac{\alpha^{TM} \Gamma^{TM} g^{TM}}{v_g^{TM}} \right] L \quad (3)$$

where  $L$  is the length of SOA,  $v_g^{TE}$  is the group velocity of the envelop of the optical electric field for TE mode,  $\Gamma^{TE}$  is the confinement factor,  $g^{TE}$  is the real gain function,  $\alpha^{TE}$  is the phase modulation parameter and  $\alpha_{int}^{TE}$  is the modal loss. All the parameters corresponding to superscript TM and TE represent the parameters for TM mode and TE mode of propagation respectively. At the PBS, the two modes coherently combine. If the phase difference  $\varphi$  is an odd multiple of  $\pi$ , the angle of rotation of the beam after combination of TE and TM mode (having almost same amplitude) at output end of SOA is  $\theta = \pi/2$  and then at the output port-2 no beam will appear. In this case the output from port-2 will be suppressed i.e. switched off. Here the induced phase difference  $\pi$  is controlled by the power of input pump beam as well as choosing the suitable parameters and length of SOA (intensity  $> 0.4$  mW) [Garai S.K.,2010,2011a].

Thus in the absence of pump beam, probe beam will appear at port-2 (ON-state) and in the presence of the pump beam of specific intensity, the probe beam will be suppressed in port-2 (OFF-state). Obviously the state of port-1 will be complementary with respect to port-2 i.e., in the presence of the pump beam, power will develop at port-1.

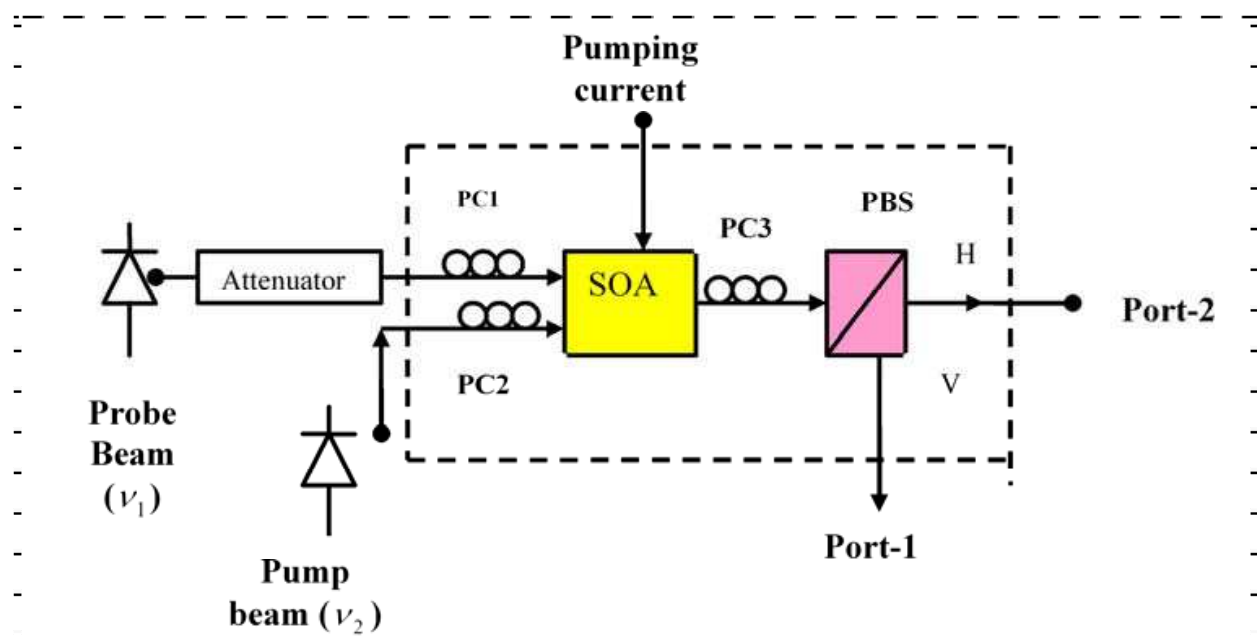

Fig. 1(c). SOA acting as a polarization switch

### 3. Conversion of decimal number to frequency encoded binary data

To implement the frequency encoded all-optical arithmetic logic (ALU) processors, generation of frequency encoded binary data is very important. In this section the author has first mentioned a method of generating intensity encoded binary data to frequency encoded binary data and subsequently explained the scheme of conversion of decimal data to frequency encoded binary data using the above mentioned action of PSW made of SOA.

The scheme of conversion of all optical decimal data to frequency encoded binary data works based on the principle of frequency conversion by polarization switches (PSW) and it is explained with the help of Fig.2(a) [Garai S.K.,2010,2011a]. The optical circuit comprises two polarization switches PSW1 and PSW2. Major part of the output beam of PSW1 is applied as the input pump beam of PSW2 and the rest part is coupled with the output beam of PSW2. The probe beam X1 of PSW1 is of frequency  $\nu_1$  and the probe beam of PSW2 is X2 of frequency  $\nu_2$ .

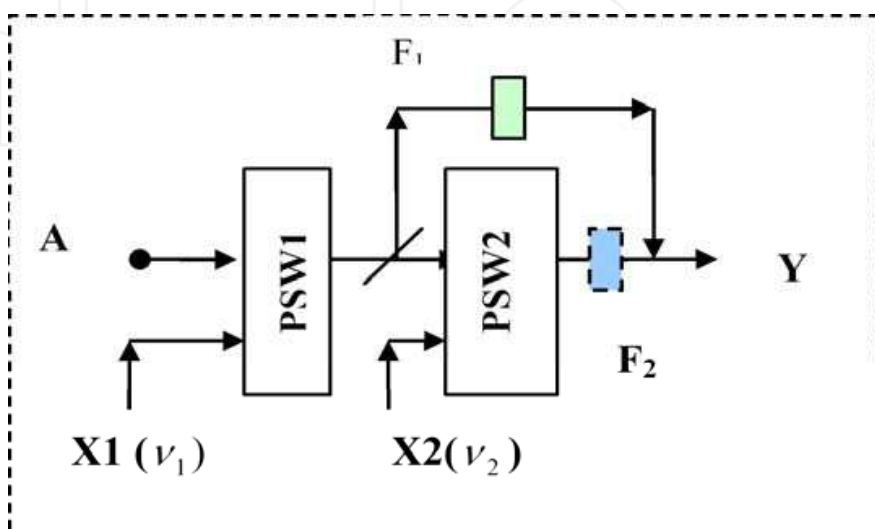

Fig. 2(a). Optical circuit for converting decimal to frequency encoded binary data

Decimal Number	Binary Number in terms of	
	'0' and '1'	' $\nu_1$ ' and ' $\nu_2$ '
0	0000	$\nu_1 \nu_1 \nu_1 \nu_1$
1	0001	$\nu_1 \nu_1 \nu_1 \nu_2$
2	0010	$\nu_1 \nu_1 \nu_2 \nu_1$
3	0011	$\nu_1 \nu_1 \nu_2 \nu_2$
4	0100	$\nu_1 \nu_2 \nu_1 \nu_1$
5	0101	$\nu_1 \nu_2 \nu_1 \nu_2$
6	0110	$\nu_1 \nu_2 \nu_2 \nu_1$
7	0111	$\nu_1 \nu_2 \nu_2 \nu_2$
8	1000	$\nu_2 \nu_1 \nu_1 \nu_1$
9	1001	$\nu_2 \nu_1 \nu_1 \nu_2$
10	1010	$\nu_2 \nu_1 \nu_2 \nu_1$
11	1011	$\nu_2 \nu_1 \nu_2 \nu_2$
12	1100	$\nu_2 \nu_2 \nu_1 \nu_1$
13	1101	$\nu_2 \nu_2 \nu_1 \nu_2$
14	1110	$\nu_2 \nu_2 \nu_2 \nu_1$
15	1111	$\nu_2 \nu_2 \nu_2 \nu_2$

Table 1. Decimal numbers and their corresponding frequency encoded binary numbers

In the absence of input pump beam 'A', the PSW1 will be in ON state which in turn will suppress PSW2. The least fraction of the output beam of PSW1 of frequency  $\nu_1$  will appear at the output. In the presence of the input beam A, the PSW1 will be in OFF state which in turn



will switch the PSW2 in ON state and thereby the beam of frequency  $\nu_2$  will be obtained at the output end.

The above mentioned technique has been exploited for the conversion of decimal (0 to 15) to binary data and it is explained with the help of Fig.2(b).

Fig.2(b) comprises four frequency converter units made of polarization switches ( $PSW_0, PSW_0'$ ), ( $PSW_1, PSW_1'$ ), ( $PSW_2, PSW_2'$ ) and ( $PSW_3, PSW_3'$ ).  $PSW_0, PSW_1, PSW_2$  and  $PSW_3$  have their common probe beam ' $X_1$ ' of frequency  $\nu_1$ , whereas another four prime polarization switches ( $PSW_0'$  to  $PSW_3'$ ) have their common probe beam ' $X_2$ ' of frequency  $\nu_2$ .  $D_0, D_1, D_2, \dots, D_{15}$  are sixteen input terminals corresponding to decimal numbers 0,1,2,3,....,15 respectively, through which optical beam of specific power is to be applied to convert a specific decimal number (corresponding to terminal number) into its binary form. For example, to convert the decimal number '9' to its binary form, a laser source of specific power [Garai S.K.,2011a] is to be applied in the terminal  $D_9$  by means of an optical switch. The beam after entering via the terminal  $D_9$  will split up into two equal parts and serve as the pump beam of  $PSW_3$  and  $PSW_1$ . The beam entering via the terminal  $D_{13}$  will serve as the pump beam of  $PSW_3, PSW_2$  and  $PSW_0$ , the beam entering via the terminal  $D_{15}$  will act as the pump beam for all four polarization switches  $PSW_3, PSW_2, PSW_1$  and  $PSW_0$  and so on. The splitting of the beams after entering through the sixteen terminals (0 to 15) and their function as the pump beam for different PSWs are presented in Table-2. The terminal  $D_0$  has no internal connection to any of the polarization switches. The output ends of the combination of polarization switch ( $PSW_3, PSW_3'$ ), ( $PSW_2, PSW_2'$ ), ( $PSW_1, PSW_1'$ ) and ( $PSW_0, PSW_0'$ ) are designated as  $Y_3, Y_2, Y_1$  and  $Y_0$  respectively and these will give the frequency encoded

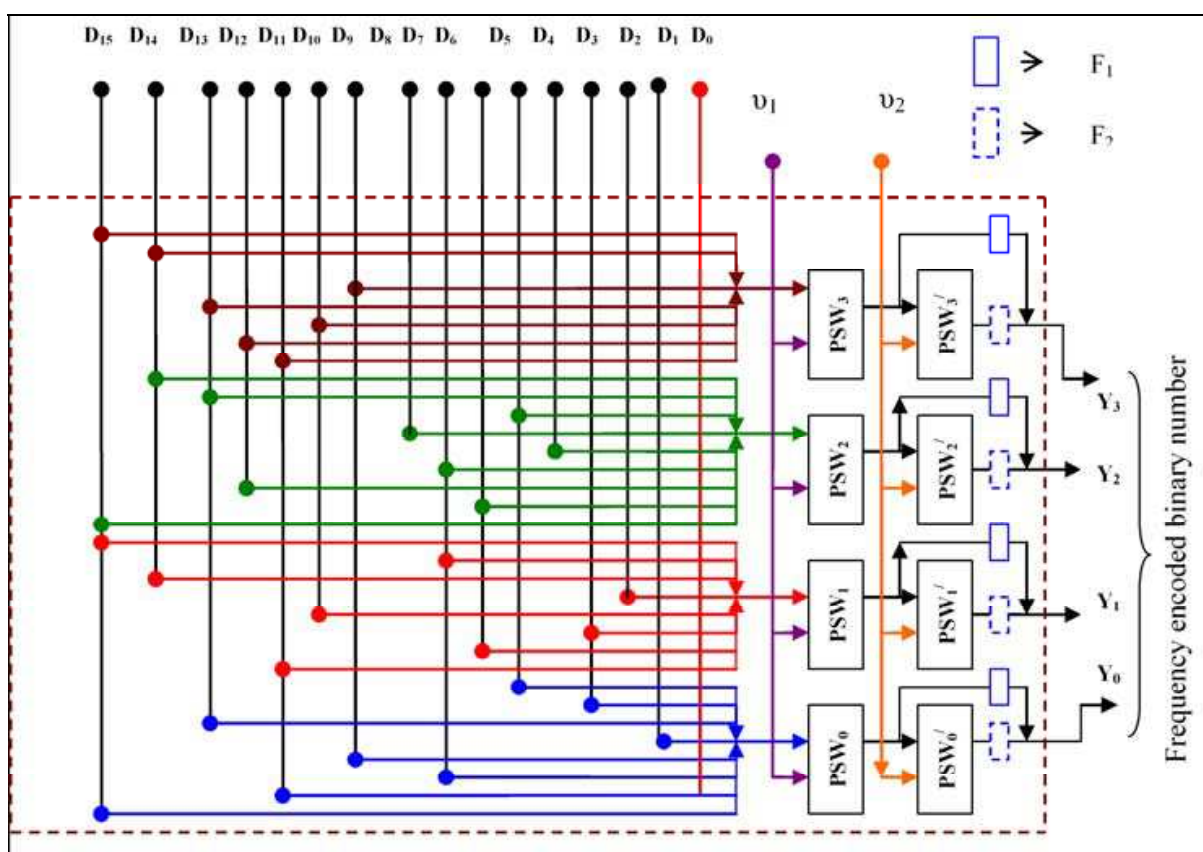

Fig. 2(b). Decimal to frequency encoded binary data conversion scheme

binary number in sequence 'Y<sub>3</sub>Y<sub>2</sub>Y<sub>1</sub>Y<sub>0</sub>' corresponding to the input decimal number. Here Y<sub>3</sub> represents the most significant bit (MSB) and Y<sub>0</sub> represents the least significant bit (LSB) of the converted binary number.

Decimal Number	Optical beam connecting terminal	No of split up parts of beam	Connected to PSW switches as pump beam	PSW in		PSW/ in		Output Y <sub>3</sub> Y <sub>2</sub> Y <sub>1</sub> Y <sub>0</sub>
				ON state	OFF state	ON state	OFF state	
0	D <sub>0</sub>	NIL	None	All	None	None	All	v <sub>1</sub> v <sub>1</sub> v <sub>1</sub> v <sub>1</sub>
1	D <sub>1</sub>	No	PSW0	1,2,3	0	0	1,2,3	v <sub>1</sub> v <sub>1</sub> v <sub>1</sub> v <sub>2</sub>
2	D <sub>2</sub>	No	PSW1	0,2,3	1	1	0,2,3	v <sub>1</sub> v <sub>1</sub> v <sub>2</sub> v <sub>1</sub>
3	D <sub>3</sub>	2	PSW0 PSW1	2,3	0,1	0,1	2,3	v <sub>1</sub> v <sub>1</sub> v <sub>2</sub> v <sub>2</sub>
4	D <sub>4</sub>	No	PSW3	0,1,2	3	3	0,1,2	v <sub>1</sub> v <sub>2</sub> v <sub>1</sub> v <sub>1</sub>
5	D <sub>5</sub>	2	PSW0 PSW3	1,2	0,3	0,3	1,2	v <sub>1</sub> v <sub>2</sub> v <sub>1</sub> v <sub>2</sub>
6	D <sub>6</sub>	2	PSW1 PSW3	0,2	1,3	1,3	0,2	v <sub>1</sub> v <sub>2</sub> v <sub>2</sub> v <sub>1</sub>
7	D <sub>7</sub>	3	PSW0 PSW1 PSW3	2	0,1,3	0,1,3	2	v <sub>1</sub> v <sub>2</sub> v <sub>2</sub> v <sub>2</sub>
8	D <sub>8</sub>	No	PSW3	0,1,2	3	3	0,1,2	v <sub>2</sub> v <sub>1</sub> v <sub>1</sub> v <sub>1</sub>
9	D <sub>9</sub>	2	PSW0 PSW3	1,2	0,3	0,3	1,2	v <sub>2</sub> v <sub>1</sub> v <sub>1</sub> v <sub>2</sub>
10	D <sub>10</sub>	2	PSW1 PSW3	0,2	1,3	1,3	0,2	v <sub>2</sub> v <sub>1</sub> v <sub>2</sub> v <sub>1</sub>
11	D <sub>11</sub>	3	PSW0 PSW1 PSW3	2	0,1,3	0,1,3	2	v <sub>2</sub> v <sub>1</sub> v <sub>2</sub> v <sub>2</sub>
12	D <sub>12</sub>	2	PSW2 PSW3	0,1	2,3	2,3	0,1	v <sub>2</sub> v <sub>2</sub> v <sub>1</sub> v <sub>1</sub>
13	D <sub>13</sub>	3	PSW0 PSW2 PSW3	1	0,2,3	0,2,3	1	v <sub>2</sub> v <sub>2</sub> v <sub>1</sub> v <sub>2</sub>
14	D <sub>14</sub>	3	PSW1 PSW2 PSW3	0	1,2,3	2,2,3	0	v <sub>2</sub> v <sub>2</sub> v <sub>2</sub> v <sub>1</sub>
15	D <sub>15</sub>	4	PSW0 PSW1 PSW2 PSW3	None	All	All	None	v <sub>2</sub> v <sub>2</sub> v <sub>2</sub> v <sub>2</sub>

Table 2. Decimal to binary conversion scheme in tabular form

Now the mode of conversion of the decimal number '0' and '13' into its frequency encoded binary number are explained with the help of Fig. 3(b).

To convert the decimal number '0' to its binary form, the laser beam is to be connected to the input terminal  $D_0$ . As the terminal  $D_0$  has no internal connection to any of the polarization switch, therefore, polarization switches  $PSW_0$ ,  $PSW_1$ ,  $PSW_2$  and  $PSW_3$  will not get any pump beam. All these switches will get only the probe beam of frequency  $\nu_1$  from common source  $X_1$  and therefore, all these switches will remain in ON state and the amplified probe beam of frequency  $\nu_1$  will appear at the output end of each polarization switch. Now all the polarization switches  $PSW_0'$  to  $PSW_3'$  will get the pump beam from previous PSWs as well as the probe beams of frequency  $\nu_2$  from common supply  $X_2$ . Combination of the pump beam and the probe beam will drive all the polarization switches ( $PSW_0'$  to  $PSW_3'$ ) to OFF state. Fractional parts of the output beam of PSWs of frequency  $\nu_1$  after passing through bypass path of PSW/s will appear at output end of  $PSW_0'$  to  $PSW_3'$ .

Hence at the output end, one will obtain the binary form of frequency encoded data ' $\nu_1 \nu_1 \nu_1 \nu_1$ ', for input decimal number '0'.

To convert decimal number '13' into its binary form, the laser beam is to be connected to  $X_{13}$  terminal. After entering through  $D_{13}$ , it will split up into three equal parts. Here the three successive split up parts will act as pump beam for  $PSW_3$ ,  $PSW_2$  and  $PSW_0$  unit respectively. The pump beams in these three units will switch off the PSWs which in turn will switch on  $PSW_3'$ ,  $PSW_2'$  and  $PSW_0'$  unit and one will obtain the amplified probe beam of frequency  $\nu_2$  at each of the output end  $Y_3$ ,  $Y_2$  and  $Y_0$ . Remaining  $PSW_1$  units will not get any pump beam and according to its function, one will get optical beam of frequency  $\nu_1$  at the output terminal  $Y_1$ . Thus, the binary number corresponds to the decimal number '13' is ' $\nu_2 \nu_2 \nu_1 \nu_2$ '.

Similarly the conversion of all other decimal number to its binary form can be explained with the help of Fig.2(b) and Table-2.

The above mentioned scheme may be extended to convert decimal numbers to binary coded decimal numbers and gray code and vice versa exploiting the above principle and that are explained in details in the work of Garai S.K.,2011a.

#### 4. Method of developing frequency encoded different logic operations

The author was presented a method to develop all optical frequency encoded binary logic gates such as NOT, AND, OR, NAND, NOR, EX-OR etc. based on the conjugate beam generation technique by PPLN waveguide and subsequently frequency routing by add/drop multiplexers and frequency conversion using reflecting semiconductor optical amplifiers (RSOA)[Garai S.K., Samanta D.,et.al.,(2008), Garai S.K., Mukhopadhyay S.,2009a,2011]. Conversion efficiency of conjugate beam generation by PPLN is not high enough and considerable amount of energy is lost to implement the logic operation. This problem was undertaken by the author and he tried to avert the intermediate conjugate beam generation, as a consequence he has supplanted the method by a new one. In this section, the author has presented a novel method to design all optical frequency encoded different logic gates exploiting the principle of nonlinear rotation of the state of polarization rotation (SOP) of the probe beam in semiconductor optical amplifier in the presence of pump beam of specific intensity ranges. Here conjugate beam generation is

not required. Hence the conversion efficiency and speed of operation are higher compared to the earlier method. The truth table of frequency encoded different logic gates are presented in Table-3.

Input data of frequency		Output of different logic gates					
A	B	AND	OR	NAND	NOR	X-OR	X-NOR
$\nu_1$	$\nu_1$	$\nu_1$	$\nu_1$	$\nu_2$	$\nu_2$	$\nu_1$	$\nu_2$
$\nu_1$	$\nu_2$	$\nu_1$	$\nu_2$	$\nu_2$	$\nu_1$	$\nu_2$	$\nu_1$
$\nu_2$	$\nu_1$	$\nu_1$	$\nu_2$	$\nu_2$	$\nu_1$	$\nu_2$	$\nu_1$
$\nu_2$	$\nu_2$	$\nu_2$	$\nu_2$	$\nu_1$	$\nu_1$	$\nu_1$	$\nu_2$

Table 3. Truth table of frequency encoded different logic units

The scheme of the experiment for implementing frequency encoded NAND logic operation exploiting the nonlinear rotation of the state of polarization of the probe beam is shown in Fig.3. 'A' and 'B' are two input terminals through which frequency encoded pump beams are applied. 'ADM1' and 'ADM2' are the optical add and drop multiplexers which are tuned for reflected frequency ' $\nu_1$ ' by the application of proper biasing current of SOAs in 'ADMs' [Garai S.K., Mukhopadhyay S., 2009, 2009b; Garai S.K., 2011c ]. The reflected signal of frequency ' $\nu_1$ ' from 'ADM1' is dropped down by circulators ' $C_1$ ' and then power of the beam is divided into two equal parts by means of 'beam splitter'(BS). One part of the beam is injected as the pump beam for 'SOA1' and another part is injected as pump beam for 'SOA2'. The reflected signal of frequency ' $\nu_1$ ' from 'ADM 2' is dropped down by circulator ' $C_2$ ' and then the beam is divided into two equal parts by means of beam splitter(BS). One of the beams is injected as the pump beam of SOA1 and another part is injected as pump beam for SOA3. The destination of the input beam 'A' of frequency  $\nu_2$  as the pump beam after passing through ADM1 is given by { SOA3, SOA4} and that of the input beam 'B' of frequency  $\nu_2$  as the pump beam after passing through ADM2 is given by { SOA2, SOA4}.  $X_1$  and  $X_2$  are two linearly polarized input probe beams of frequency ' $\nu_1$ ' and ' $\nu_2$ ' respectively. The state of polarizations are maintained by polarization controllers(PC).The beam  $X_2$  is split up into three equal parts which are serving as the weak probe beam of SOA1, SOA2 and SOA3 respectively. Output of each 'SOA' is selected by an optical filter each having pass frequency equal to its corresponding input probe beam frequency. The final output is 'Y' which is obtained by connecting the output of each SOA after passing through polarization beam splitters (PBS). Initially the state of polarization of input probe beams are oriented in such a way that output from each PBS is zero in the absence of pump beams. Now the NAND logic operation is explained with the help of Fig3.

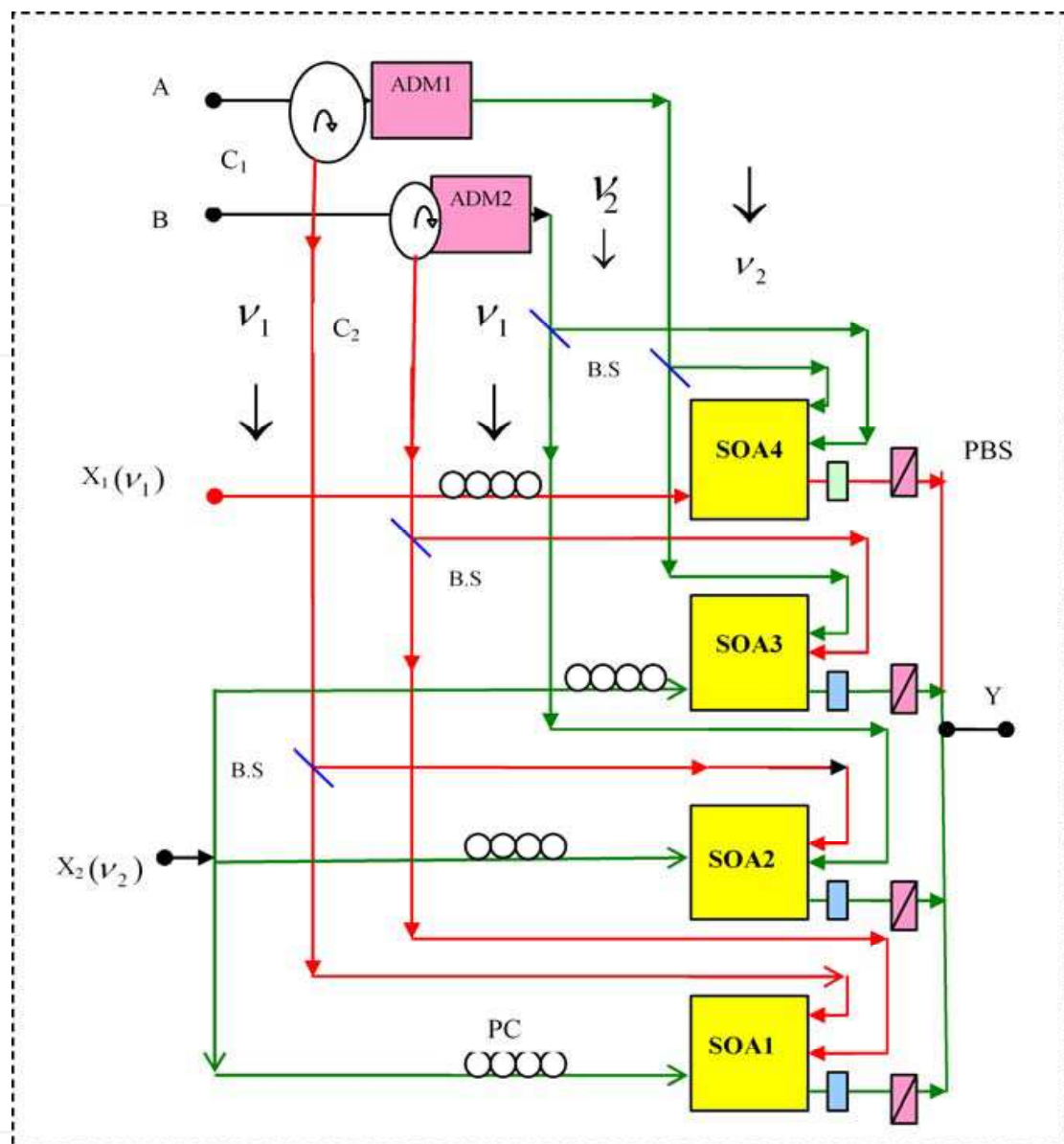

Fig. 3. Scheme of implementing frequency encoded NAND logic operation

**Case-1: Both the input pump beams A and B are of frequency ' $\nu_1$ ' i.e. both are at '0' state**

Now both the pump beams of frequency ' $\nu_1$ ' will be reflected from 'ADM1' and 'ADM2' and dropped down by circulators ' $C_1$  and ' $C_2$  respectively'. The destination of the input beam 'A' of frequency  $\nu_1$  as the pump beam is given by {SOA1, SOA2} and that of the input beam 'B' of frequency  $\nu_1$  as the pump beam is given by {SOA1, SOA3}. Thus SOA1 will get both the input pump beams whereas all other 'SOAs' get at most one pump beam at a time. Therefore both the pump beams of SOA1 can significantly rotate the state of polarization of input probe beam ' $X_2$ ' of frequency  $\nu_2$  and a polarization beam splitter (PBS) at the output end can detect the nonlinear polarization rotation in terms of intensity difference. As a result output beams of 'SOA1' will give a beam of frequency  $\nu_2$  at the cost of the input pump beam each of frequency  $\nu_1$ .



**Case-2: Input pump beam 'A' is of frequency ' $\nu_1$ ' i.e. at '0' state and the B is of frequency ' $\nu_2$ ' i.e. at '1' state**

Now the destination of the input beam 'A' of frequency  $\nu_1$  as the pump beam after reflecting back by ADM1 is given by { SOA1, SOA2} and that of the input beam 'B' of frequency  $\nu_2$  as the pump beam after passing through ADM2 is given by { SOA2, SOA4}. Under this situation 'SOA2' only will get both the pump beams at the same time. These two pump beams can significantly rotate the state of polarization of input probe beam 'X<sub>2</sub>' of frequency  $\nu_2$  and as a result output beam of 'SOA2' will give a beam of frequency  $\nu_2$ .

**Case-3: Input pump beam 'A' is of frequency ' $\nu_2$ ' i.e. at '1' state and the 'B' is of frequency ' $\nu_1$ ' i.e. at '0' state**

Now the destination of the input beam 'A' of frequency  $\nu_2$  as the pump beam after passing through ADM1 is given by { SOA3, SOA4} and that of the input beam 'B' of frequency  $\nu_1$  as the pump beam after reflecting back by ADM2 is given by { SOA1, SOA3}. Therefore under this situation 'SOA3' only will get both the pump beams. These pump beams can significantly rotate the state of polarization of the probe beam 'X<sub>2</sub>' and as a result output beam of 'SOA3' will give the beam of frequency  $\nu_2$  at the output end of PBS.

**Case-4: Both the pump beams are of frequency ' $\nu_2$ ' i.e. both are at '1' state**

Now the destination of the input beam 'A' of frequency  $\nu_2$  as the pump beam after passing through ADM1 is given by {SOA3, SOA4} and that of the input beam 'B' of frequency  $\nu_2$  as the pump beam after reflecting back by ADM2 is given by {SOA3, SOA4}. Thus both the input pump beams are injected at 'SOA4' whereas other SOAs get at most one pump beam. Therefore both the pump beams of 'SOA4' can significantly rotate the state of polarization of input probe beam 'X<sub>1</sub>' of frequency  $\nu_1$  and as a result output beam of 'SOA4' will give a beam of frequency  $\nu_1$  at the output end.

Thus using input pump beams of frequencies  $\nu_1$  and  $\nu_2$  as input data, it is possible to get a frequency encoded NAND logic operation. NAND logic gate is the universal logic gate and all other logic gates can be developed using NAND gates only.

The utility of the above mentioned scheme is that the same circuit can be used to implement any one out of the 16 binary logic operations, only by properly selecting the frequency of the probe beam of the four SOA units. As for example, if the frequency of the probe beams SOA1 and SOA4 unit be  $\nu_1$  (X<sub>1</sub>) and that of SOA2 and SOA3 unit be  $\nu_2$  (X<sub>2</sub>), then it is possible to execute frequency encoded X-OR logic operation using the same circuit.

The block diagram of frequency encoded different logic units with proper distribution of probe beams X<sub>1</sub>( $\nu_1$ ) and X<sub>2</sub>( $\nu_2$ ) in four probe beam terminals of SOA units i.e., SOA1, SOA2, SOA3 and SOA4, designated by 1,2,3 and 4 respectively are as shown in Fig.4.

The above mentioned scheme may be extended to design all optical multiplexer and demultiplexer [Garai S.K., Mukhopadhyay S.(2009)], data comparator[Garai S.K.(2011)] multivalued logic unit such as trinary [Garai S.K., 2010], quaternary etc. logic gates and all optical arithmetic logic unit [Garai S.K.(2011c)].

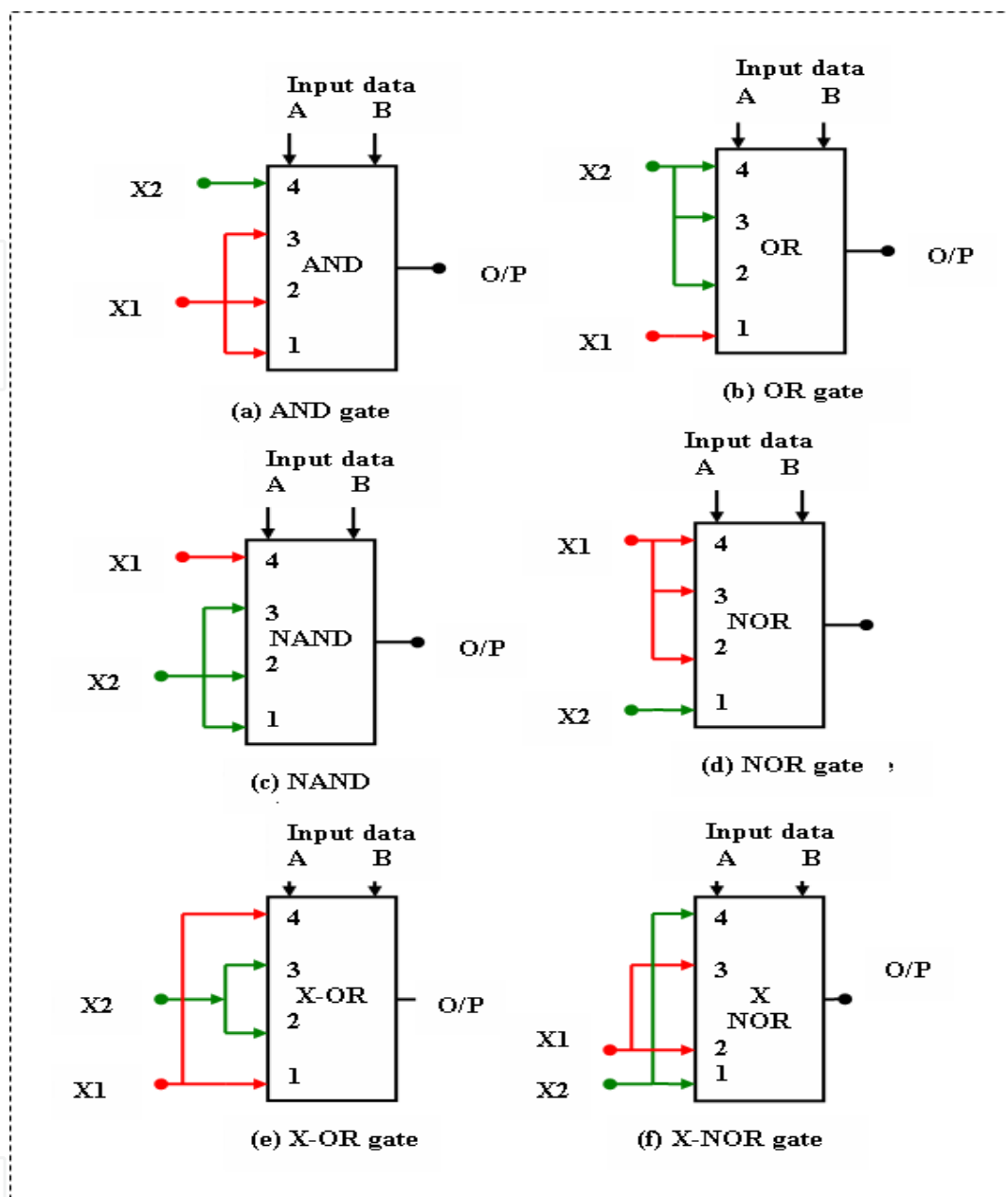

Fig. 4. Block diagram of different logic units

## 5. All optical frequency encoded memory unit

The very fast running optical memory and optical logic gates are the basic building blocks for any optical computing and data processing system. Realization of a very fast memory-cell in the optical domain is very challenging one. In last two decades many methods of implementing all-optical flip-flops have been proposed. Most of these suffer from speed limitation because of slow switching response of the active devices [Zhang S. et.al.,2005, Ghosal et.al.,2008, Fatehi M.T. et.al.,1984]. In this present chapter the author presents a method of developing a frequency encoded memory unit based on the polarization switching action of semiconductor optical amplifier (SOA) using frequency encoded data [Garai S.K., Mukhopadhyay S.,2010 ].

The basic building blocks of the memory unit consists of three polarization switches PSW1 and PSW2 [Garai S.K., 2010, 2011a], an isolator, two input sources  $X_2$  and  $X_1$  giving the probe beams having frequencies  $\nu_2$  and  $\nu_1$  respectively and one add/drop multiplexer, ADM as shown in Fig.5. The beam obtaining from output port-2 of PSW1 splits up into two parts by means of beam splitter B.S. One part of the beam is coupled as the input pump beam for polarization switch PSW2 and another part is serving as the output data (Y). Similarly, the output beam from port-2 of PSW2 is split up into two parts. One part is serving as the probe beam of PSW3 switch via an attenuator  $A_T$  and another part is viewed as output at Y terminal via the attenuator. The low intensity input probe beam of PSW3 switch is controlled by the isolator. The function of the isolator is that it allows the part of the output beam of PSW2 to appear at Y end but prevents the output of PSW1 to appear at the input end of PSW3. 'A' is the input pump beam terminal of switch PSW1. The input pump beam is injected to PSW1 via add/drop multiplexer ADM. The ADM is tuned for reflection frequency  $\nu_2$ . The reflected beam of frequency  $\nu_2$  is reflected back by ADM and drop down by circulator and injected as the pump beam (control beam) for PSW3. The beam obtained at the output port-2 of PSW3 is coupled with input pump beam 'A' by a beam coupler (B.C.).

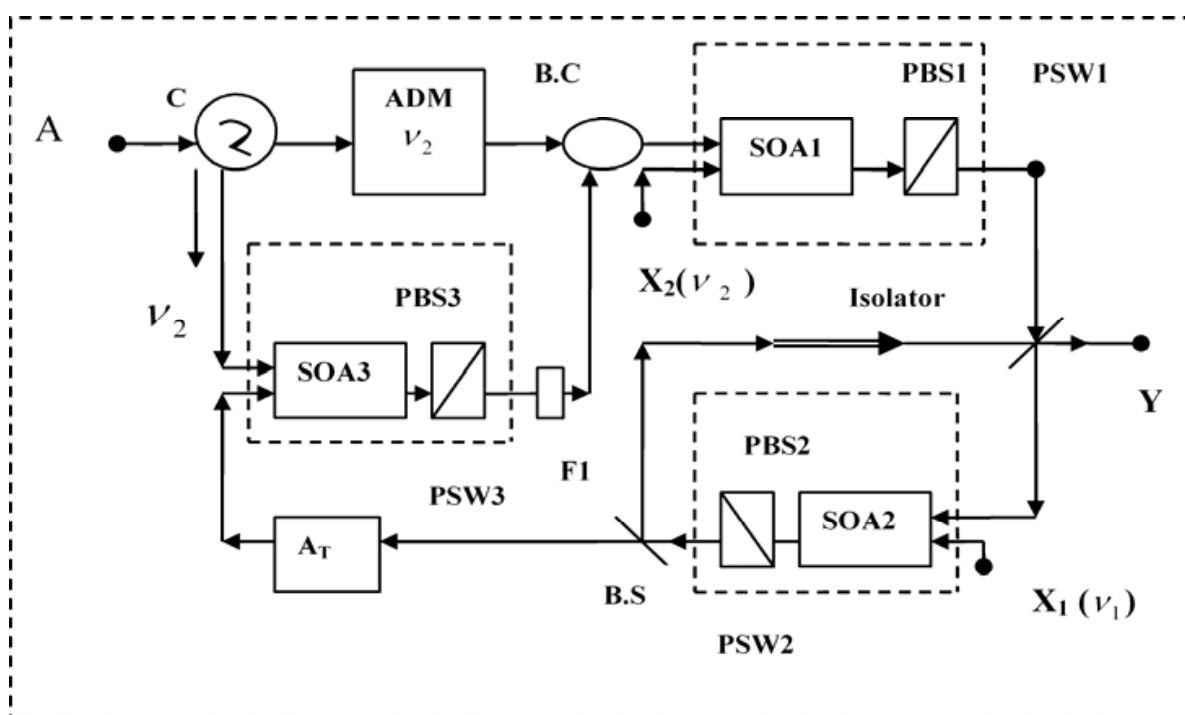

Fig. 5. Frequency encoded single bit memory circuit

The operation of the frequency encoded memory unit is now explained with the help of Fig.6. Here the frequency of optical signal ' $\nu_1$ ' (corresponding wavelength  $\lambda_1$ ) is encoded as 0 state and the frequency  $\nu_2$  (corresponding wavelength  $\lambda_2$ ) as the state 1. If the input beam 'A' be of frequency  $\nu_1(0)$ , then it will pass through ADM and behaves as the pump beam for polarization switch PSW1. As the probe beam  $X_2$  of PSW1 is of frequency  $\nu_2$ , therefore, by the joint action of pump and probe beam the PSW1 goes to switch off state i.e. output of PSW1 will give no signal (zero). Now the polarization switch PSW2 will get only probe beam signal  $X_1$  of frequency  $\nu_1$  and according to the action of polarization switch

the PSW2 will be in ON state i.e. output of PSW2 is the signal of frequency  $\nu_1$ . A fraction of the beam of frequency  $\nu_1$  will be displayed at the final output and the intensity of the remaining part will be attenuated to a value so that a desired low intensity beam is serving as probe beam of PSW3 switch. In PSW3 since no pump beam is present, the probe beam of frequency  $\nu_1$  will appear at the output port-2 and finally it is coupled with the input pump beam of PSW1 of frequency  $\nu_1$ . Therefore optical beam of frequency  $\nu_1(0)$  will remain at the output end (Y) of the memory unit.

Now if the input beam A of frequency  $\nu_1$  is removed from the circuit, the output beam of frequency  $\nu_1$  of port-2 of PSW3 will serve as the input pump beam for switch PSW1 which leads to switch off the PSW1 and in turn it will switch on PSW2. Thus the signal of frequency  $\nu_1(0)$  will continue to remain at the output end Y.

If the input beam 'A' is of frequency  $\nu_2(1)$  then it will be reflected back by ADM and drop down by circulator and behave as the pump beam for PSW3. As no pump beam for switch PSW1 is present, so this switch will come to the ON state and the amplified probe beam  $X_1$  of frequency  $\nu_2$  will appear at the output end of PSW1. This output beam with the joint action of probe beam  $X_2$  switch off the PSW2. Therefore no signal will be obtained from output end of PSW2. Now no signal probe beam being present at PSW3, no probe beam will appear at the output port-2. Again probable leakage pump beam of frequency  $\nu_2$  in port-2 is blocked by  $\nu_1$  pass filter  $F_1$ . Therefore no beam from the output end of PSW3 will be injected as pump beam for switch PSW1. Thus PSW1 will remain at ON state giving constant output signal of frequency  $\nu_2$  when the input signal A is of frequency  $\nu_2$ .

<b>Input beam A of frequency</b>	<b>Data stored at output (Y)</b>
<b><math>\nu_1</math></b>	<b><math>\nu_1</math></b>
<b>OFF</b>	<b><math>\nu_1</math></b>
<b><math>\nu_2</math></b>	<b><math>\nu_2</math></b>
<b>OFF</b>	<b><math>\nu_2</math></b>
<b><math>\nu_1/\nu_2</math></b>	<b><math>\nu_1/\nu_2</math></b>
<b>OFF</b>	<b>Last input data</b>

Table 4. Excitation table of frequency encoded memory unit.

Now if the input signal 'A' of frequency  $\nu_2$  is removed, both the pump beam and probe beam will be absent at the input end of PSW3 and as a result no output beam will appear at the port-2. Again no pump beam being present at the input end of PSW1 switch, it will remain in on state giving amplified probe beam of frequency  $\nu_2$  at the output end. This output beam in turn will drive the switch PSW2 to OFF state and no beam will be obtained at the output port-2 of PSW3. Thus when the input beam of frequency  $\nu_2$  is withdrawn, the

signal of 'frequency-  $\nu_2(1)$ ' will remain stored at the output end 'Y'. The excitation table of the memory unit is as shown in Table-4.

This scheme may be extended to design multivalued memory unit with some extra circuit elements [Garai S.K., Mukhopadhyay S.(2010)] as well as designing multivalued flip-flops [Garai S.K.,2012]exploiting the same working principle.

## 6. Conclusion

Whole operation is all-optical one, so one can expect a very high speed of operation from the system. Considering the present scenario of speed and band width limitation of electronic computing, signal processing and future problem of data traffic, the author has developed all these frequency encoded all optical logic units, and memory unit which will be very useful in all optical computing and the optical networking. All these optical gates and memory units are suitable to perform so many advanced functions in communication based network such as in all-optical bit pattern recognition, all-optical bit-error rate monitoring, all optical packet addressing and pay-load separation, all optical label swapping, all optical packet drops in optical time domain multiplexing (OTDM) etc. The frequency encoded all these all optical logic processors are expected to be very useful in present days as well as in near future for wavelength division multiplexing and demultiplexing networks.

Here the author has selected the wavelength of the encoded inputs signals corresponding to the encoded signal of frequencies  $\nu_1(0)$  and  $\nu_2(1)$  in C band (1536 nm -1570 nm) and these are respectively 1540 and 1550nm. The advantages of using C-Band is that here the frequency conversion gain is almost independent of frequency. The separation between two consecutive encoded wavelength '5 nm' is sufficient. The function of optical 'add/drop multiplexer' is very specific about frequency of reflection and it merely allow to pass a spreading of frequency. Again, at the output end as only the beam of one frequency is obtained at a time, therefore, there is no question of crosstalk. To maintain the state of polarization (SOP) of probe beams polarization controller (necessary polarizer) is to be used. The performance of SOA based optical logic processors are preferred as SOA based optical switches are more efficient because of its higher nonlinearity with least switching power (<-3dB<sub>m</sub>) and high switching contrast ratio (20dB). Here the speed of the operation is depending on the switching speed of SOA based state of polarization rotation of the probe beam as well as the switching speed of coupled version of different circuit elements within the interconnecting fibers. It also depends on the distances of different units and propagation distance between two SOAs. The operating speed of SOA switch is restricted to 100 Gb/s due to its response time of gain saturation in regular SOA. Though switching speed of individual circuit element is very high (of the order of sub Pico second), however, the speed of the couple version will be reduced to 40 to 50 GHz due to propagation delay (order of nanosecond) within the interconnecting fibers. However very fast response (100 Gb/s) can be achieved using quantum dot SOA-MZI switch [Ju H.,et.al.,2005; Sun H., et.al.,2005; Vyrsoinos K., et.al.,2010] and quantum dot SOA as polarization rotation switches with an integrated circuit. The fast switching action of SOA enhances the speed of logic operation and as a result the speed of processing becomes faster for multi-bit operation. Therefore the above-mentioned scheme demands for overall feasibility, practicality and versatility of designing all optical logic processor system with very high speed.



## 7. References

- Asghari M., White I.H., Penty R.V., 'Wavelength conversion using semiconductor optical amplifiers, *J.Lightwave Technology*, Vol.15, No.17,1997, pp.1181-1190
- Awwal A.A.S., Karim M.A.(1990), 'Microprocessor design using polarization encoded optical shadow casting', *Appl. Opt.*, Vol.29, No.14,1990, pp. 2107-2112.
- Chakraborty B., Mukhopadhyay S.(2009), 'Alternative approach of conducting Phase-modulated all-optical logic gates', *Optical Engineering*, Vol. 48, No.3, March 2009, pp.035201-5.
- Connelly M.J.(2008), 'Semiconductor Optical Amplifiers', Kluwer Academic Publishers, 2002
- Dorren H.J.S., Lenstra D., Liu Y, Hill M. T., Khoe G.D.(2003), 'Nonlinear Polarization Rotation in Semiconductor Optical Amplifiers: Theory and Application to All-Optical Flip-FlopMemories", *IEEE Journal of Quantum Electronics*, Vol.39, No.1, 2003, pp.141-148.
- Dutta N.K., Wang Q.(2006), 'Semiconductor Optical Amplifiers', World Scientific Publishing, Singapore, 2006(Chapter 8).
- Fatehi M.T., Wasmundt K.C., Collins S.A.(1984), 'Optical flip-flops and sequential logic circuits using a liquid crystal light valve', *Appl. Optics*, Vol.23, No.13, 1984,pp.2163-2171.
- Fu S., Zhong W.D., Shum P., Wu C., Zhou J.Q.(2007), 'Nonlinear Polarization rotation in semiconductor optical amplifiers with linear polarization maintenance', *IEEE Photonics Technology Letters*, Vol.19, No.23,2007, pp.1931-1933.
- Garai S.K.(2010), 'A scheme of developing frequency encoded tristate-optical logic operations using Semiconductor Optical Amplifier', *Journal of Modern Optics*, Vol.57, No.6,2010, pp.419-428.
- Garai S.K.(2011), 'A method of developing frequency encoded multi-bit optical data comparator using Semiconductor Optical Amplifier', *Optics and Laser Technology*, Vol.43, No.1, 2011, pp.124-131.
- Garai S.K.(2011a), 'Method of all-optical frequency encoded decimal to binary and BCD, binary to gray' and gray to binary data conversion using semiconductor optical amplifiers', *Applied Optics*, Vol.50, No.21,2011,pp.3795-3807.
- Garai S.K.(2011b), 'A novel method of designing all optical frequency encoded Fredkin and Toffoli logic gates using semiconductor optical amplifiers', *IET Optoelectronics*, Vol.5, No.6, 2011, pp.247-254.
- Garai S.K.(2011c), "A novel all-optical frequency encoded method to develop Arithmetic and Logic Unit (ALU) using semiconductor optical amplifiers," *IEEE/OSA Journal of Light wave Technology*, Vol.29, No.23, 2011, pp. 3506-3514.
- Garai S. K.(2012), 'A novel method of developing all optical trinary JK, D-type and T-type flip-flops using semiconductor optical amplifiers', *Applied Optics*, (In Press-20.12.2011)
- Garai S. K., Mukhopadhyay S.(2009), 'Method of implementing frequency encoded multiplexer and demultiplexer systems using nonlinear Semiconductor Optical Amplifiers', *Optics and Laser Technology*, ,Vol.41, No.8,2009, pp.972-976 .

- Garai S. K., Mukhopadhyay S.(2009a), 'Method of implementing frequency encoded NOT, OR and NOR logic operations using Lithium niobate waveguide & Reflecting Semiconductor Optical Amplifiers', PRAMANA-journal of physics, Vol.73, No.5, 2009, pp.901-912.
- Garai S.K., Mukhopadhyay S.(2010), 'A novel method of developing all-optical frequency encoded memory unit exploiting nonlinear switching character of Semiconductor Optical Amplifier', Optics and Laser Technology, Vol.42, No.7, 2010, pp.1122-1127.
- Garai S.K., Mukhopadhyay S.(2011), 'A scheme of developing frequency encoded tristate logic operations exploiting non-linear character of PPLN waveguide and RSOA', Optik, Vol.122, No. 6, 2011, pp. 498-501.
- Garai S.K., Mukhopadhyay S.(2009b), 'Method of implementation of all-optical frequency encoded logic operations exploiting the propagation characters of light through Semiconductor Optical Amplifiers', J.Opt, Vol.38, No.2, 2009, pp.88-102.
- Garai S.K., Samanta D., Mukhopadhyay S.(2008), 'All-optical implementation of inversion logic operation by second harmonic generation and wave mixing character of some non-linear material', Optics and Optoelectronic technology, Vol6, No.4, 2008, pp.39-42.
- Garai S.K., Pal A., Mukhopadhyay S.(2010), 'All optical frequency encoded inversion operation with tristate logic using Reflecting Semiconductor Optical Amplifiers' Optik, Vol.121, No.16, 2010, pp.1462-65
- Ghosal A. K., Basuray A.(2008), 'Trinary flip-flops using Savart plate and spatial light modulator optical computation in multivalued logic', Optoelectronics Letters, Vol.4, 2008, pp. 0443-0446 .
- Jiang Y., Luo X., Hu L., Wen J., Li Y.(2010), 'All optical add-drop multiplexer by utilizing a single semiconductor optical amplifier', Microwave and Optical Technology Letters, Vol.52, No.9, 2010, pp.1977-1980.
- Ju H., Zhang S., Lenstra D., de Waardt H., Tangdiongga E., Khoe G. D., Dorren H. J.S.(2005) 'SOA-based all-optical switch with subpicosecond full recovery', Optics Express, Vol.13, No. 3, 2005, pp.942-947
- Lacey J.P.R., Summerfield M.A., Madden S.J.(1998), ' Tunability of polarization insensitive wavelength converters based on four-wave mixing in Semiconductor Optical Amplifiers, J.Lightwave Technology, Vol.16, No.12, 1998, pp.2419-2427.
- Liu Y., Hill M.T., Tangdiongga E., Waardt H.de, Calabretta N., Khoe G.D., Dorren H.J.S.(2003), 'Wavelength conversion using Nonlinear Polarization Rotation in a Single Semiconductor Optical Amplifier', IEEE Photonics Technology Letters, Vol.15, No.01, 2003, pp.90-92.
- Soto H., Erasme D., Guekos G.(1999), 'Cross-polarization modulation in Semiconductor Optical Amplifier', IEEE Photon. Technol. Lett. Vol.11, No.8, 1999, pp.970-972.
- Sun H., Wang Q., Dong H., Dutta N.K.(2005), 'XOR performance of a quantum dot semiconductor optical amplifier based Mach-Zender interferometer', Optics Express, Vol.3, No.06, 2005, pp.1892-1899.
- Toyohiko Y.(1986), 'Optical space-variant logic gate based on spatial encoding technique', Optics Letters, Vol.11, No.4, 1986, pp. 260-262.

- Vyrsokinos K., Stampoulidis L., Gomez-Agis F., Voigt F. K., Zimmermann L., Wahlbrink T., Sheng Z., Thourhout D.V., Dorren H.J.S.,(2010) 'Ultra-high Speed, all-optical wavelength converters using single SOA and SOI photonic integrated circuits', Photonics Society Winter Topicals Meeting Series (WTM), IEEE,2010,pp.113-114, doi:10.1109/PHOTWTM.2010.5421936
- Yu S., Gu W.(2005), 'A tunable wavelength conversion and wavelength add/drop scheme based on cascaded second order nonlinearity with double pass configuration', IEEE J. Quantum Electron, Vol.41. No.7, 2005, pp. 1007-1012
- Zaghloul Y.A., Zaghloul A.R.M.(2006), 'Unforced polarization based optical implementation of Binary logic', Optic Express, Vol.14, No.16, 2006, pp.7252-7269.
- Zaghloul Y. A., Zaghloul A. R. M. and Adibi A. (2011), 'Passive all-optical polarization switch, binary logic gates, and digital processor', Vol.19, No.21, 2011, pp.20332-20346
- Zhang S., Li Z., Liu Y., Khoe G. D. and Dorren H. J. S.(2005) 'Optical shift register based on an optical flip-flop memory with a single active element', Optics Express , Vol.13,No.24,2005,pp.9708-9713

IntechOpen

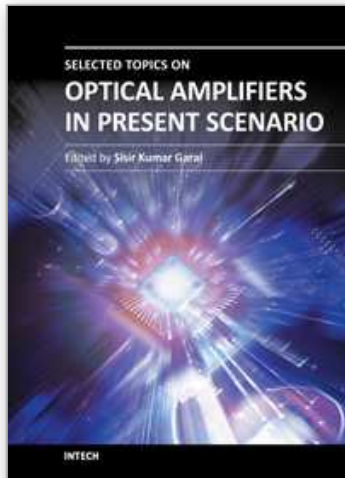

## **Selected Topics on Optical Amplifiers in Present Scenario**

Edited by Dr. Sisir Garai

ISBN 978-953-51-0391-2

Hard cover, 176 pages

**Publisher** InTech

**Published online** 23, March, 2012

**Published in print edition** March, 2012

With the explosion of information traffic, the role of optics becomes very significant to fulfill the demand of super fast computing and data processing and the role of optical amplifier is indispensable in optical communication field. This book covers different advance functionalities of optical amplifiers and their emerging applications such as the role of SOA in the next generation of optical access network, high speed switches, frequency encoded all-optical logic processors, optical packet switching architectures, microwave photonic system, etc. Technology of improving the gain and noise figure of EDFA and, the study of the variation of material gain of QD structure are also included. All the selected topics are very interesting, well organized and hope it will be of great value to the postgraduate students, academics and anyone seeking to understand the trends of optical amplifiers in present scenario.

### **How to reference**

In order to correctly reference this scholarly work, feel free to copy and paste the following:

Sisir Kumar Garai (2012). A Novel Method of Developing Frequency Encoded Different Optical Logic Processors Using Semiconductor Optical Amplifier, Selected Topics on Optical Amplifiers in Present Scenario, Dr. Sisir Garai (Ed.), ISBN: 978-953-51-0391-2, InTech, Available from:  
<http://www.intechopen.com/books/selected-topics-on-optical-amplifiers-in-present-scenario/a-novel-method-to-implement-frequency-encoded-all-optical-logic-processors-using-semiconductor-optic>

**INTECH**  
open science | open minds

### **InTech Europe**

University Campus STeP Ri  
Slavka Krautzeka 83/A  
51000 Rijeka, Croatia  
Phone: +385 (51) 770 447  
Fax: +385 (51) 686 166  
[www.intechopen.com](http://www.intechopen.com)

### **InTech China**

Unit 405, Office Block, Hotel Equatorial Shanghai  
No.65, Yan An Road (West), Shanghai, 200040, China  
中国上海市延安西路65号上海国际贵都大饭店办公楼405单元  
Phone: +86-21-62489820  
Fax: +86-21-62489821

© 2012 The Author(s). Licensee IntechOpen. This is an open access article distributed under the terms of the [Creative Commons Attribution 3.0 License](#), which permits unrestricted use, distribution, and reproduction in any medium, provided the original work is properly cited.

IntechOpen

IntechOpen