

We are IntechOpen, the world's leading publisher of Open Access books Built by scientists, for scientists

4,800

Open access books available

122,000

International authors and editors

135M

Downloads

Our authors are among the

154

Countries delivered to

TOP 1%

most cited scientists

12.2%

Contributors from top 500 universities



WEB OF SCIENCE™

Selection of our books indexed in the Book Citation Index
in Web of Science™ Core Collection (BKCI)

Interested in publishing with us?
Contact book.department@intechopen.com

Numbers displayed above are based on latest data collected.

For more information visit www.intechopen.com



Isolator System For Laboratory Infectious Animals

Xin Pan

*Animal Biosafety Level 3 Laboratory,
Second Military Medical University, Shanghai,
China*

1. Introduction

The international mutual acceptance of safety data in certification and accreditation system have led to high-level bio-safety laboratories becoming an irreplaceable hardware in peacetime for the study of pathogen in emerging and re-emerging infectious disease, and in important international activities for detection and identification high-risk pathogen in antiterrorism security.

In an effort to minimize the risks for scientists exposure to the infectious environment and avoiding infectious incident, high-level bio-safety laboratories are designed and constructed to improve experimental safety by preventing laboratory infectious waste causing harm to people or the environment. The possibility of high-risk pathogens spread to the public environment with flow of people and materials and water and air is strictly controlled by improvement physical protection to reduce human infection rates and incidence of environment contamination to zero. The air flow safety, including interior mechanical ventilations and the suction and exhaust process in large working process equipments, is ensured by installing air conditioning system, air filter system, one working and one on standby extraction blowers, constant or variable air volume damper in pipes, automation and monitoring system, and power supply system (including dual power supply system and online emergency power supply) to maintain suitable directional negative filtering air flow with constant temperature and humidity working conditions for the operators. The materials flow safety, including experimental materials, laboratory animals and laboratory infectious waste, is mastered by installing transfer system (including delivery window and double port transfer exchange system) and sterilization system (double-doored autoclave). The liquid flow safety, including launching and softened water, is controlled by reverse osmosis disinfection system and independent sewage discharge system (including high temperature and high pressure sterilizer and chemical disinfection tank). The people flow safety, including walking around in the laboratory, carrying out experimental procedures, changing protective clothing, and physiological activity such as respiration, is protected by primary barriers (including biological safety cabinet and negative-pressure isolator), secondary barriers (building envelope and facility construction), third barriers (personal protective equipment, PPE), communication systems between the lab and outside, visual monitoring devices and alarm system.

In high-level bio-safety laboratories, animals infected with Risk Group 3 pathogens (as defined by the World Health Organization) must be housed in isolation chambers (World Health Organization, 2004). Animal isolation system is used broadly in laboratory research, pharmaceuticals and medical areas, gene modified animals, and gnotobiotic animals. Isolators were developed for studying the disease of scrub typhus in 1940 during the Second World War (Bantin, 2004). Today, the isolators are much more advanced, especially the commercial rodent isolator systems (Wathes & Johnson, 1991). But for infectious medium-sized animal (sheep, pigs, goats, nonhuman primates, dogs, cats, rabbits and chickens) research, the market normally supplied semi-open negative pressure cabinet. This kind of cabinet can not provide completely physical barrier for safeguarding animal and occupational health and the odors and allergens environment, because the directly face-to-face manipulation exist between animal and operator in the research procedure. The Class III biological safety cabinet (glove box) was mainly used for experiment operation (Kruse et al., 1991), its internal work area was maintained negative pressure during running state, it was able to provide security, even in the physical prevent contamination system failure. The requirements for wind speed and pressure were relatively higher to maintain the glove box internal laminar flow, but were not conducive to animal care, the occupants had to suffer high stress and uncomfortable environment under the high velocity air flow. If the glove box was simply expanded to an isolator, large area filtration equipment was easy to plug, animal welfare was difficult to achieve in insufficient space (limited height) (Huang, 2005). Recently we developed a set of automatic multi-functional isolation system for feeding (Pan et al., 2010) and dissection and micrurgy laboratory animals carrying infectious diseases. The isolation system, including the transfer chain, disinfection chain, negative air pressure isolation system, animal welfare system and the automated system, are designed to meet all biological safety standards.

Isolator was mainly designed to separate the internal controlled environment from external environment, and the operator from the experimental process and products. The primary aim was to prevent the leakage of the contaminated products within the internal environment to the external environment, or the penetration of substances of the external environment into the internal environment, or both simultaneously (Tattershall, 2006). Isolators were used to improve operators and process safety, avoid operator wearing too many protective suits, improve operator comfort and flexibility and personnel availability, improve safety level against operator errors, completely control the contaminated material and minimize the contaminated area (Sawyer et al., 2007).

There are many types of isolators, mainly included positive pressure isolators and negative pressure isolators. Specified-pathogen-free (SPF) laboratory animals housed in positive pressure isolators for the protection of any animals inside the isolator from outside contaminants (Clough et al., 1995). Infectious animal housed in negative pressure isolators to prevent migration of hazardous contaminants to the outside (Wathes & Johnson, 1991).

In general, the commonly used physical separation mainly included rigid and soft barriers (ISO 14644-7:2004). Rigid barriers can be made of many different materials, and the more rigid the material, the more reliable the physical barrier. Construction of these rigid barriers usually makes of plastic enclosures, metal profile enclosures or hot-worked metal enclosures (ISO 10648-1:1997). The isolation chamber is designed to house a living animal, and therefore continuous airflow inside the enclosure is needed to drive out heat and moisture generated by the animal's metabolism and to decrease the concentration of odor, dust, and infectious substances (Hillman et al., 1992). The resulting exhaust gas is subject to

a filtering system designed to prevent pathogen contamination of the external environment (Institute of Laboratory Animal Resources Commission on Life Sciences, National Research Council, 1996). The aerodynamic is joined in the physical separation cabinet to allow for one-way flow or turbulence of the airflow inside the isolation chamber, negative pressure relative to the environment. Supply and exhaust air can be passed through high-efficiency particulate air filters (HEPA) to prevent the formation of aerosols that could potentially escape into the environment (Runkle et al., 1969).

Double port transfer exchange (DPTE) system is used in the isolator to allow the transfer of experiment materials from one container to another without exposing the experiment material to the outside environment (Allen et al., 2009). The technology was developed in the early 1960s by a French company for the French nuclear industry to greatly reduce Alpha and Beta exposures and Gamma dose. The acronym DPTE was originally derived from the French phrase 'double porte de transfert etanche', meaning double door sealed transfer or double door transfer port. A newly validated rapid transfer port boasts bi-directional transfer as one of its features, a system also known as an Alpha-Beta transfer port or rapid transfer port (RTP) (Michael et al., 2004). The biological sciences involving dangerously toxic or infectious materials (such as poisons, bacteria or viruses) also need to use DPTE system as the transfer tool to enclose the dangerous materials without escaping into the surroundings.

Laboratory animal models are often susceptible to a number of diseases and parasites found in humans or economic animals (Tauraso et al., 1969). The similarities of genetic, physiological, and behavioral characteristics between research objects and laboratory animal models, and the occurrence of similar pathological changes upon infection, have led to laboratory animal models becoming an irreplaceable experimental materials for the study of pathogen infection, the screening of anti-pathogen drugs, and vaccine evaluation (Pan & Sun, 2004; Conly & Johnston, 2008). Because of the critical role that laboratory animal models play in the study of these pathogens, it is critical to find safe and reliable methods for their physical containment.

2. Isolator system composition and structure

The structure of stainless-steel medium-sized animal breeding isolator and acrylic mice breeding isolator and acrylic anatomy isolator and acrylic micrurgy isolator include top ventilation unit, isolator working zone, lower part of control system and isolator support frame (Fig. 1).

The isolation chamber is supported by type 304 stainless-steel isolation chamber support stand. The ventilation unit is on the top of the isolation chamber. Stainless-steel slideways are mounted on the top of the isolation chamber box. The pipes, air blower, valve, and adjustable illumination lamp are fastened to the reserved mounting holes or mounting plates of the slideways by a fixing screw.

Two extraction blowers share one exhaust port in which an anemometer is installed. Each of the extraction blowers is connected with its own coupling clamp to the outlet ventilation pipe, exhaust ventilation pipe and exhaust electronic control ball valve to form an exhaust channel. The two exhaust channels have a parallel connection. Two sets of sterilizing agent bypass tubes have a series connection with an ipsilateral sterilizing agent bypass electronic control ball valve, and a parallel connection with the same side of the exhaust ventilation

pipe on two ends of the exhaust electronic control ball valve. All of the valves are automatically controlled by the programmable logic controller (PLC).

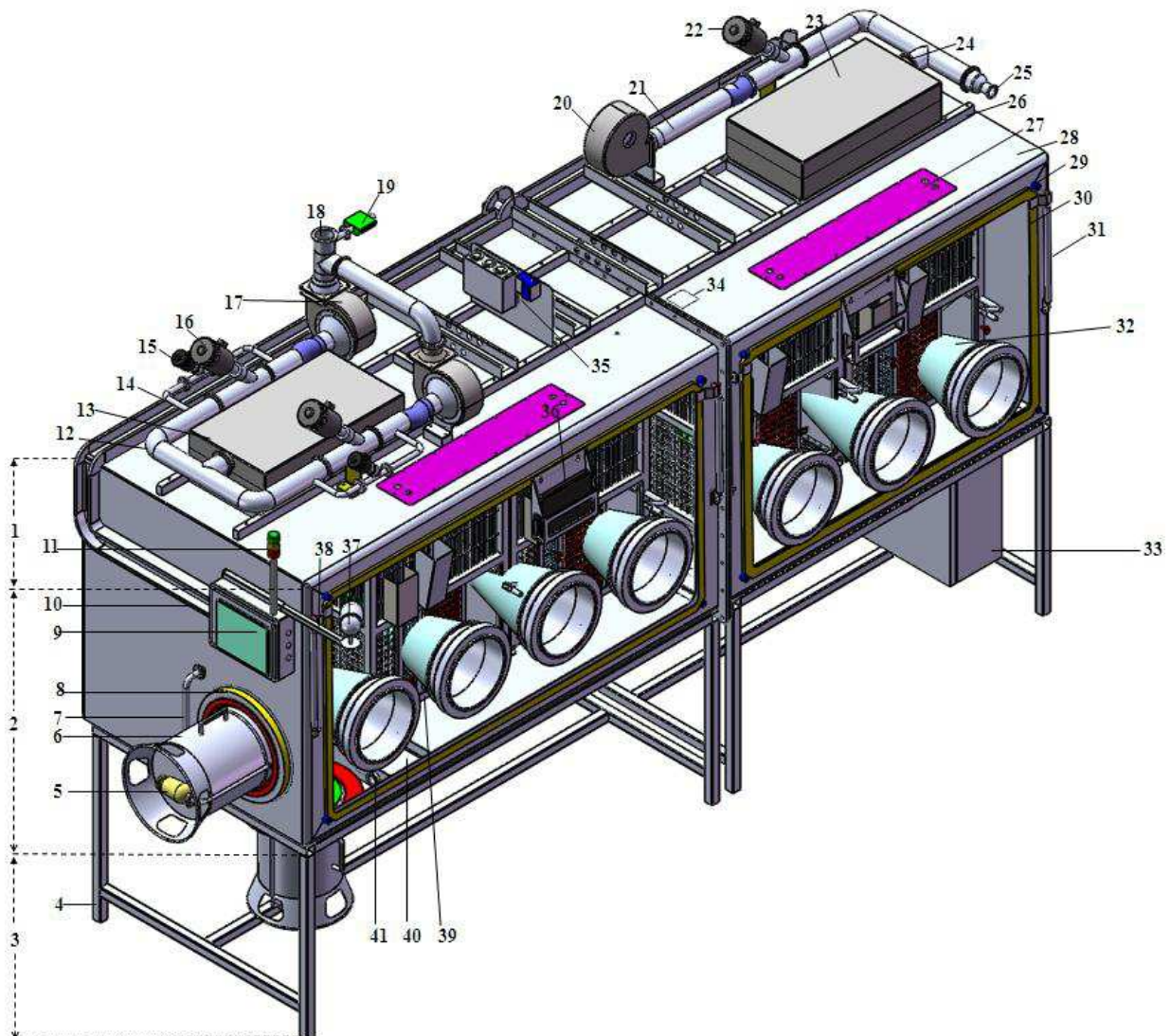

Fig. 1. Structure diagram of stainless-steel medium-sized animal breeding isolator. 1. top ventilation unit; 2. isolation chamber working zone; 3. lower part of the control system; 4. isolation chamber support stand; 5. transfer bin container HEPA filter; 6. DPTE 270 transfer bin container; 7. water inlet pipe; 8. DPTE 270 α door; 9. control touch panel; 10. cable duct; 11. alarm indicator light tower; 12. exhaust ventilation pipe; 13. Two in series HEPA exhaust filters; 14. sterilization bypass pipe; 15. sterilization bypass electric control ball valve; 16. exhaust electronic control ball valve; 17. extraction blower; 18. exhaust export; 19. anemometer; 20. inlet air blower; 21. inlet ventilation pipe; 22. inlet air electronic control ball valve; 23. inlet HEPA filter; 24. coupling clamp for inlet ventilation pipe; 25. sterilization reagent import; 26. top installation slideway; 27. adjustable illumination lamp; 28. stainless-steel box; 29. television-installed box; 30. front door; 31. damping-brace for the front door; 32. glove and sleeve system; 33. control cabinet; 34. temperature humidity sensor; 35. micro-differential pressure sensor; 36. flat television; 37. rotatable camera; 38. installed camera base; 39. animal cage; 40. disinfection pool; 41. drain valve.

The airflow direction through the isolation chamber via the air inlet and outlet is shown in Figure 1. Room air is drawn into the interior of the isolation chamber through the inlet pre-filter, inlet air blower, inlet ventilation pipe, inlet air electronic control ball valve, and inlet HEPA filter in the animal breeding mode. The air from the isolation chamber is drawn out of the exhaust export through two exhaust HEPA filters arranged in series, exhaust ventilation pipe and exhaust electronic control ball valve via an extraction blower. The HEPA filters are arranged in series to ensure that if one fails, the other can still ensure exhaust security and prevent pathogens from being discharged into the atmosphere.

The isolation chamber interior pressure is controlled by automated instrumentation that is connected to the supply and exhaust ventilation system. The automatic pressure regulation system is capable of maintaining the relative pressure inside the isolation chamber via the exhaust ventilation system, which can account for transient volume changes such as glove entry or withdrawal.

The isolation chamber working zone is composed of chamber, doors, glove-sleeve system and DPTE system. The welded box of medium-sized animal breeding isolator is manufactured using dumb-gloss stainless-steel 316L with a thickness of 3 mm. The adhesion acrylic isolator is manufactured with 10mm polymethylmethacrylate (PMMA).

The stainless-steel isolation chamber front door includes damping braces on each front side with dual-pistons mechanism for holding the front door securely open to let the animal cages in, operation panels with stainless-steel 316L framework and the door hinges connected to the stainless steel box. The operation panel is made of transparent PMMA. The transparent front door allows for visualization of the contents of the isolation chamber. Silicone seals around the PMMA panel ensure that the system is air tight. The front door is manually fastened onto the box framework with a hammer bolt. One gas-tight water service valve with a serrated hose is mounted on one side interior. A spray gun is connected to the serrated hose for cleaning the isolator. Animal cages can be placed on the stainless steel cage slideways in the isolator. The slideways are attached to the isolator bottom in a manner that allows cage movement in a direction along the axis perpendicular to the axis of the isolator front door. The type of animal cages can be changed, but each time just only one kind of animal species cages can be inside. In a breeding isolator all the cages share the same air space so the same microbiologically or genetically must be assure.

One door is used as a sidewall in the acrylic isolator. It allows the internal equipments and frames entry. The door can be fixed on the PMMA panel by compressing the gasket and pressure ring around the edge of the door until all the screws are tightened.

There are circular polyethylene (PE)-machined glove ports on the operation panels. The glove-sleeve port inner diameter is 300 mm and the center-to-center spacing of each port is 450 mm. The glove port assembly includes a glove port ring, glove port gasket, pressure ring and glove port inner-securing ring. The glove port ring and glove port inner-securing ring are jointed with a thread connection. The glove port ring edges are fixed on the PMMA panel by compressing the glove port gasket and pressure ring on each side of the PMMA panel by tightening a fixing screw.

The changeable sleeve and glove combination is mounted on the glove port through a sleeve fixing ring that secures the elastic Hypalon sleeve onto the glove port inner-securing ring. A glove port bung connects the glove and sleeve. Neoprene glove shapes are ambidextrous.

The transfer system for the isolation chamber is composed of DPTE systems. The DPTE system with an alpha transfer door is built into one wall of the isolation chamber using a transfer port assembly kit. The transfer port assembly kit includes the DPTE transfer port external flange, DPTE transfer port external flange sealing ring and DPTE transfer port internal flange. The DPTE transfer port external flange is fixed onto the inside isolation chamber wall by compressing the DPTE transfer port external flange sealing ring on the outside of the isolation chamber wall with a tightening fixing screw.

The transfer container is autoclavable and contains a beta door that can be manually docked to the port. The depth of the transfer container can be changed according to the research projects, its volume is enough to transfer the animal or material into the isolator. The transfer container can be autoclaved without compromising its containment and can be opened with a specialized tool to remove the sterilized waste. It also can be opened with the specialized tool in the negative pressure exhaust hood, the samples (such as animal blood samples) can be moved out for further analysis (e.g. centrifugation), while the transfer container is closed and put into a sterilizable plastic bag for autoclaving. This system works very well for rapidly and safely transferring experimental materials and animals and waste.

A videotape system mounted on the control touch panel stainless-steel box on the side of the medium-sized animal breeding isolator includes a rotatable camera and camera-installation base. The camera installation base is fastened to the control touch panel stainless-steel box by fixing screws. The position of the rotation camera can be adjusted by using the telescopic locking nut and rotating locking nut. This system enables recording of both the scientist's experimental procedures and the status of animals living in the isolation chamber. The video is displayed on the personal computer (PC) screen and saved automatically in the central control room through the control interface connected to the videotape system.

To ensure the comfort and welfare of animals in the isolation chamber, chambers are equipped with an automatic light control system and a television entertainment system. The automatic light control system includes adjustable illumination lamps and a lampshade. The adjustable illumination lamps are composed of three cold light lamps and their conditioners. The illumination system can be used to meet the needs of the animal's physiology, as well as experimental requirements.

The television entertainment system consists of a flat television and the transparent television installation box fastened to the front door by fixing screws. The animal can watch the appropriate television program to reduce depression associated with the space constraints faced by the animals and to ensure the ethical treatment of the animals.

The videotape system and lamps and television do not mount on the acrylic isolators. The videotape system and lamps in the laboratory can provide related services for transparent acrylic isolators.

The composition of the isolation control system includes an alarm indicator light tower, liquid crystal display (LCD) touch screen and control cabinet. The liquid crystal display touch screen is fastened on the outside of the isolation chamber by a fixing screw.

The PLC is built into the control cabinet. The control cabinet, which has a fan and a filter cover, is mounted onto the stainless steel shelf of isolator support stand through fasteners and fixing screw.

3. Intelligent control of isolator system

Simatic Manager Step 7 software installed in the PLC central processing unit (CPU), and through the LCD touch screen enables users to automatically control a variety of options. The animal breeding mode program, leakage test program, sterilization program, auto/manual control mode, maintenance mode, and custom procedure can all be automatically controlled by the PLC CPU and associated touch screen (Pan et al., 2010).

The management system for isolator touch screen is developed by Simatic Wincc flexible software. The operation and any system failures can be recorded and printed. The data interchange between PLC and touch screen is made possible through an industrial trunk Profibus decentralized periphery (DP).

The temperature, humidity, illumination, atmospheric pressure and air flow velocity are measured by appropriate sensors, and the values are imported to the PLC through control lines. Normal value ranges for each parameter can be programmed into the PLC, and if the parameter values deviate from the set upper and lower limits, the PLC automatically adjusts the interior environment of the isolator to match the programmed values. For example, the levels of humidity, illumination and ventilation can all be controlled by the PLC to adjust values back to pre-determined normal levels. If the PLC is unable to bring the parameter back into a normal range, the digital output module in the PLC lights an alarm bulb and sounds a buzzer, as all alarms are indicated with both a warning light and sound.

The control system controls alarms for a variety of isolation chamber problems including major equipment error alarms (such as the air blower or HEPA), major parameter alarms when values are out of the desirable ranges (such as temperature, humidity, illumination, atmospheric pressure, air exchange rate and air flow velocity), an alarm when switching to the uninterruptible power supply (UPS) / emergency power supply (EPS) and alarms for experimental failure or error (such as negative pressure breeding mode procedures or pressure test procedures).

To control pressure, a micro-differential pressure sensor is mounted on the side of the first exhaust filter. The analog module in the PLC compares the values of program settings with the values collected from the micro-differential pressure sensor, and automatically conducts proportional-integral-differential (PID) regulation. The adjusted output values are used to control blower velocity through the output module of the PLC, regulating the isolation chamber internal pressure. If a plug or leak occurs, the micro-differential pressure sensor transmits the detected signal to the PLC. If the detected values are beyond the scope of the pre-loaded high and low pressure settings, the exhaust electronic control ball valve and inlet air electronic control ball valve automatically shut down to maintain the isolation chamber as a fully-contained environment and to prevent the escape of pathogens into the outside environment. At the same time an alarm indicator light tower would start to sound an Alarm, and the touch-screen would display information on the alarm. The alarm

information would then be transmitted to the lab server through the industrial Ethernet module in the PLC. The alarm message displayed is recorded onto the lab server for analysis at a later date.

The blower rotation rate and frequency are automatically controlled by the PLC system to ensure that the airflow velocity, air exchange rate, and atmospheric pressure match the set values. If one exhaust blower fails, the PLC system responds by switching to another backup exhaust blower to ensure ventilation safety and the internal negative pressure state of the isolation chamber.

The cold light lamp regulator is controlled by the PLC digital output module to automatically adjust the illumination time according to animal behavior. The illumination time and intensity can be set from the touch screen by the operator and automatically executed. The lamps also can be switched on or off manually to meet different lighting requirements during an experimental operation.

Temperature and humidity sensors are equipped within the isolator. The isolator internal temperature is maintained within 18~29°C, and relative humidity is kept within 40~70%. The isolator internal temperature and humidity electrical signals are collected by the PLC analog module, visualized as the project value (actual values of temperature and humidity), and automatically displayed and recorded on the touch screen. The values also recorded on the lab server.

4. Installation isolator system in high-level biosafety laboratory

The design of isolator system in high-level biosafety laboratory must consider about types and groups of laboratory animals, shape and actual area of the experiment field in order to the effective utilization of the independent negative-pressure ventilation system of the robust isolator offering maximizing population density and the welfare of animals. The isolator support frames and box bodies can be assembled after laboratory partitions and self-leveling floors and cable ducts on the sidewall all being in the right place. Once the large-scale isolators have been installation, the movements are quite difficult.

The vent thread hose mounted on the exhaust export of the isolator is connected to laboratory heating, ventilation and air conditioning (HVAC) exhaust main pipe via constant volume venturi valve and dynamoelectric airtight valve. The airflow velocity through each open glove port can be regulated using the external venturi valve. The air from the type 304 stainless-steel main pipe is drawn out of the exhaust export through the exhaust in-place scan testable HEPA filter combination unit via the laboratory extraction blower. This connection can reduce the exhaust exports of the building and comply with environmental protection requirements.

The isolator locating leaks may be detected by placing a dish of ammonia and using compressed air to pressurize with a positive pressure of up to 1000 Pa. Suspected areas will turn blue for the leaked ammonia reacts with bromine on the covered yellow bromide developing cloth. Leaks are commonly in soft and hard junction. The gel has to be removed and the sealing ring has to be cleaned or replaced and resealed with gel.

5. Detection the technology performance parameters of isolator system

The technology performance parameters of isolator system are established according with related China national standards and European standards and international standards (Table 1).

TSI8386A-M-GB multi-parameter ventilation meter is used to detect airflow differential pressure, vertical section airflow velocity and air velocity into open glove port. BCJ-1 airborne particle counter is used to measure air cleanliness. TES-1350A sound level meter is used to monitor noise. Testo540 luxmeter illumination tester is used to measure illumination. MARK- II micro manometer was used to test alarm function. TSI8386A-M-GB and HM34C humidity / temperature meter are used to checkout pressure integrity. Test procedures are carried out according to the protocol as GB50591-2010, GB19489-2008 and ISO10648-2:1994 described.

Apply power and clean compressed air to the isolator before testing. The main power on the control cabinet is first turned on. Turn on the lock-controlled switch. The experimental personnel exit the lab to start and run the high-level biosafety laboratory HVAC in central control room. Personal protective clothing should be worn when entering the running normally lab to perform testing work. Detecting equipments are transferred into isolation chamber by DPTE container. The starting and stopping control and the setup of operating parameters of isolator can be controlled by staff to adopt computer technology to remote control in central control room, or to implement on-the-spot control with control touch panel of the isolator. The current operating parameters are displayed on the touch screen interface and can be adjusted by the operator following the interface prompts.

The room lamps are turned off in order to measure the independent illumination system of the stainless-steel isolator. The illumination of acrylic isolator without independent lamp is detected by using the lab illumination system.

The accuracy temperature control of air-conditioning system with all fresh air in the lab is 0.5°C. The HVAC has to be turned off when using pressure change method to test the isolator leak tightness. The leak rate test data are obtained by detecting in relatively stable room temperature. The glove-sleeve systems need to be changed by blind plates. Each overexpansion glove-sleeve in 1000Pa can create tiny deformation to change volume during the pressure changing and the air volume changes can result in significant pressure attenuation during the multi-glove-sleeve system detection stage. Flexible film windows of micrurgy isolator also have to be changed by blind plates.

The glove-sleeve system must be in place during operation and a breach in glove integrity can be serious consequence. The multi-glove-sleeve system cannot complete extension into the isolator in -250 Pa. The guideline for ABSL-4 building enclosure integrity test on GB19489-2008 is selected for measurement the isolator with the multi-glove-sleeve system or flexible film windows or both in place. The natural attenuation of pressure is less than 250 Pa in 20 min when the isolator internal air pressure down to -500Pa. This test is also a good

Testing Items	Parameters	Reference
Temperature, °C	18~29	Architectural and technical code for laboratory animal facility. GB50447-2008
Diurnal temperature, °C ≤	4	
Relative humidity, %	40~70	
Vertical section airflow velocity, m/s ≤	0.2	
Air changes per hour, ACH	8~50	Laboratory animal- requirements of environment and housing facilities. GB14925-2001
Airflow differential pressure, Pa	20~150	
Air cleanliness, class	100~10000	
Settling microbe, cfu/(Φ90mm • 0.5h)	0	
Light / dark rhythms, h	12/12 or 10/14	
Animal illumination, lux	5~200	Architectural and technical code for biosafety laboratories. GB50346-2004
Working illumination, lux ≥	150	
Noise, dB ≤	68	
Air velocity into open glove port, m/s ≥	0.7	Biotechnology-Performance criteria for microbiological safety cabinets. EN 12469:2000
-1000 Pa hourly leak rate (rate acceptance test), h ⁻¹ <	2.5×10^{-3}	Containment enclosures - Part 2: Classification according to leak tightness and associated checking methods. ISO10648-2:1994
-500 Pa pressure attenuation in 20 min (glove- sleeve in place), Pa ≤	250	Laboratories-General requirements for biosafety. GB19489-2008

Table 1. The technology performance parameters of isolator.

way to perform to be sure the leak rate is in the tolerable range before starting the experiment. This kind of periodic testing should be established and recorded for comparison preventative maintenance requirements.

The test results of isolator system have been compiled together in table 2 and they all meet technology criterion. The isolator internal dust concentration test indicate that the result for particle size $\geq 0.5 \mu\text{m}$ is ≤ 3.5 particles/L, for particle size $\geq 5.0 \mu\text{m}$ is 0 particles/L. It is supposed that the air cleanliness in isolator internal is Class 100. The temperature of the isolator internal is 0.1-0.5°C below room temperature. The relative humidity of the isolator internal is determined by the lab atmosphere.

Isolator -1000 Pa pressure decay test results show in figure 2. During the acceptance test, inlet air blower, inlet air electronic control ball valve, sterilizing agent by-pass electronic control ball valve, exhaust electronic control ball valve and extraction blower are all closed. Part of the inlet ventilation pipes, an inlet HEPA filter, two exhaust HEPA filters arranged in series, part of exhaust ventilation pipes and part of sterilizing agent bypass tubes are all in the range of pressure integrity testing. If leakage present in the installed HEPA filters, the negative or positive pressure tests will be failure. Anyway the isolators pass through the

Type of isolator	Vertical section airflow velocity (m/s)	-1000Pa hourly leak rate(h^{-1})	-500Pa pressure attenuation in 20min (Pa)	Air velocity into open glove port (m/s)	Airflow differential pressure ΔP (pa)	Interior dust concentration (Particles/L)				Noise [dB(A)]	Illumination (average values)	
						Maximum average values of measuring points			Statistical mean values in isolator working zone		Animal illumination	Working illumination
						$\geq 0.5\mu m$	$\geq 5.0\mu m$	$\geq 5.0\mu m$				
						$\geq 0.5\mu m$	$\geq 5.0\mu m$	$\geq 5.0\mu m$				
medium-sized animal breeding isolator	0.03	1.54×10^{-3}	76.1	0.72	-55.9	0	0	0	0	60.8		
mice breeding isolator	0.06	1.59×10^{-3}	31.4	0.72	-65.8	0	0	0	0	67.3		282
anatomy isolator	0.04	1.03×10^{-3}	132.6	0.71	-62.5	0.24	0	0.15	0	64.7		349
micrurgy isolator	0.02	0.96×10^{-3}	101.4	0.70	-51.6	0.47	0	1.10	0	67.1		367

Table 2. Measuring results of isolators.

leakage rates tests in both positive and negative states. During normal operation, the directional air flow from the isolation chamber to the exhaust export and into the attached thread chimney should pass through two exhaust HEPA filters arranged in series. Airborne contaminants in the isolator are removed by the two HEPA filters, so the vent thread hose and the part of the exhaust ventilation pipes installed behind the electronic control ball valves need not do the leak rate test with the isolator. Even the leakage present among the hoses, the laboratory is in the negative pressure atmospheric conditions, the emitted particles can be mechanical captured by the lab filters. The exhaust in-place scan testable

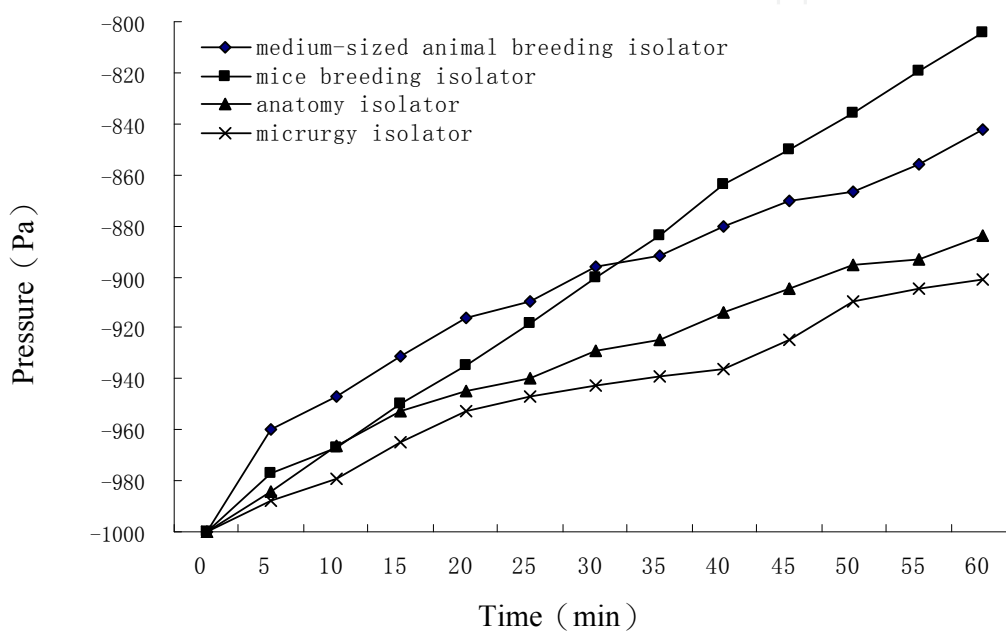

Fig. 2. Negative 1000Pa pressure decay test of isolator.

HEPA filter combination housing assembly is another important downstream exhaust filter devices of isolators and the lab before the air flow can disperse to the environment. The airborne contaminants can be detected by the leakage detection device of the unit if the leaks occur in-service. The actual test results of the exhaust filter units downstream are zero particles/L.

The maximum airflow rate of the isolator is 180 m³/h and the maximum air exchange rates is 36 ACH. The airflow rates of the laboratory are 740 ~ 3900 m³/h and are excessively greater than the airflow rate of the isolator. The isolators are turned on or off one by one via remote control by the dedicated computer in the central control room, and the lab pressure changes being observed actually have no significant effect.

Testing of the alarm system of isolator is essential to ensure proper function. The value of negative pressure is reduced by manually exposing the glove port when the isolation chamber running normally. Buzzer alarm of the isolator alarms as loss of pressure when the negative pressure absolute value of the isolator internal is less than 20Pa. The resistance of

exhaust HEPA filter is increased artificially covering the isolator filter with plastic membrane. Buzzer alarms as filter blocking.

6. Operation method of isolator system

The isolation chamber should be monitored for 48 hours to ensure that it is running normally in a Class 10000 high-level bio-safety laboratory. This includes supplying filtered air to the isolator and ensuring that the exhaust air is cleaned by the double in-line HEPA filters and passed through the exhaust air system into the open air. Fresh air exchanges should be conducted at a rate of about 36 air changes per hour. Following 48 hours of monitoring, the inside temperature is 22~23 °C, the relative humidity is 60%, the working negative pressure in the isolation chamber is adjusted to -50 Pa with respect to the laboratory. Healthy animals should be passed through the quarantine system and transferred into the isolation chamber via the DPTE system.

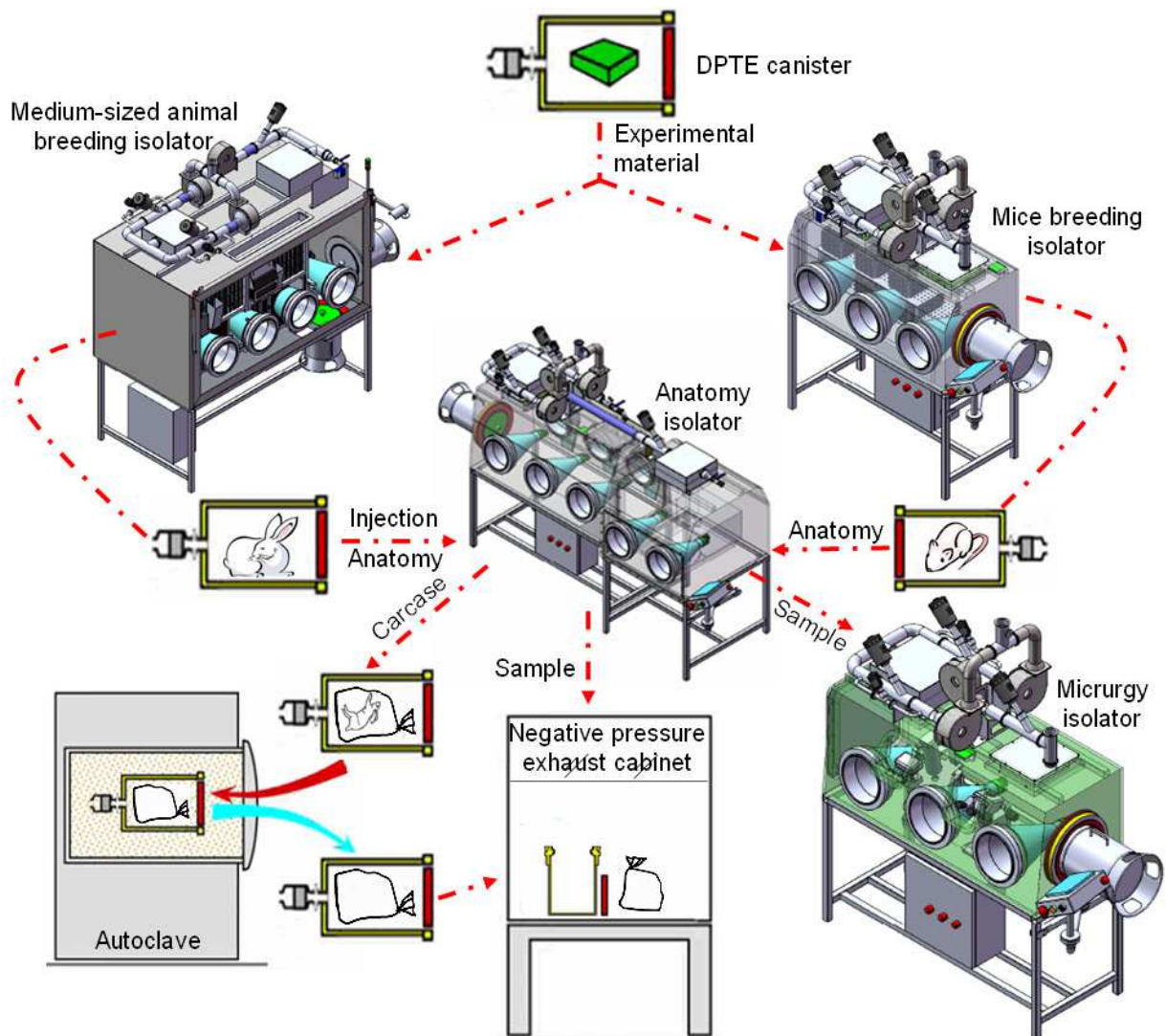

Fig. 3. DPTE systems are used to realize the transfer of experiment materials among different types of isolators and associated instruments.

The experiment in isolator systems can be carried out according to the protocol showing in figure 3.

The feeds and aseptic water can be kept enough in the isolator to minimize disturbances to breeding animals. The glove-sleeve systems allow direct complete animal feeding operations without compromising the health status or contamination of the animals within the isolator. Rapid pressure changes when operating under transient volume changes such as glove entry or withdrawal are adjusted via a variable frequency drive inlet air blower and extraction blower.

Non-human primates breeding need special approval by government, so New Zealand white rabbits are the first residents in the medium-sized animal breeding isolators. The animal excrement and other waste materials are cleaned out by DPTE container and sent to sterilize by autoclave every week. The rabbits selected for immunity with inactive pathogen are moved to the anatomy isolator with large space in an independence room by DPTE system to perform the operation of injection. The animal is sent back to the breeding isolator in the breeding room by transfer container after injection.

The ventilation performance of mice breeding isolator in mice breeding room allows using ordinary transparent mice cages and water bottles, and an extended cage-changing period up to one month (6 mice per cage, ~15g/mice). The changed cages without mice are transferred to autoclave by DPTE system.

The operation of animal anatomy can be performed in the anatomy isolator. Blood of immunity rabbit can be transferred to negative pressure exhaust cabinet by transfer canister. The β -door of the canister can be opened with a specialized tool, and the blood samples can then be removed to the biological safety cabinet for further stages of analysis (e.g., centrifugation), while the transfer canister is closed and sent into autoclave. The Leica CM1100 cryostat in the anatomy isolator can be used to rapid freezing and manual sectioning of animal tissue specimens. The frozen section slides of mice infected by attenuated strain of pathogen are packaged and transferred to micrurgy isolator for immunostaining assays and observing under a fluorescence microscope in the micrurgy isolator. It is determined by the fluorescence microscopy that the attenuated strain of pathogen in mice tissues is specific binding with its strain-specific rabbit antiserum. The image data are sent out from the lab local area network. The dead animal and experimental waste materials in the isolator are collected respectively into plastic bags for autoclaving by DPTE canister.

The animal experiment should be performed according to bio-safety operation standard procedures. If the gloves are removed during the operation, a low pressure audible/visual alarm system is activated, and a minimum velocity value of 0.7 m/s in the center of the glove port is maintained. If a glove is damaged by a needle, the blowers are capable of maintaining the isolation chamber pressure at -50 Pa but the alarm system would not be activated because the micro-differential pressure sensor is not sensitive enough for a leak of this size. Proper procedure dictates that the small hole be labeled by the operator and a new glove exchanged. All of the feeds, experimental material, waste, feces and other materials can be transferred into or out of the isolation chamber by the DPTE system. There are several breeding isolation chambers in one room, and the autoclave does not connect with any of them. Instead, DPTE beta canisters are filled with items and are then sterilized in the

autoclave. After sterilization, the sterile items are removed after opening the beta door with specialized tools. The sterile items are then sent to a centralized disposal center for medical waste. Following the completion of studies with single animals, each animal is treated as dictated by bio-safety operation standards and general animal welfare. The cadavers are autoclaved in beta canisters and sent to animal carcass disposal sites.

7. Isolator system decontamination

The isolator systems need biodecontamination after finishing the breeding program and experiment. The choice of sterilant depends on what kind of devices in the isolator. If only the cages are in the isolator, or there is nothing in the isolator, the stainless-steel or acrylic isolation chamber can be connected to the peracetic acid sterilizer to sterilize the interior of the isolation chamber. During the sterilization process, inlet air blower, inlet air electronic control ball valve, exhaust electronic control ball valve and extraction blower are all closed. Raven Labs offered *Bacillus atrophaeus* spore strips can be used for sterility testing by Soproper in isolator sterilization environments. Amount (A) of Soproper in the evaporation reservoir of peracetic acid sterilizer can be calculated with the formula: $A \text{ (mL)} = T \times 70 \text{ mL/h} + 150 \text{ mL}$, where T = sterilization time (h). The sterilizing agent by-pass electronic control ball valve is opened. The sterilizing agent in the peracetic acid sterilizer evaporation tank is heated and its vapors are pushed by compressed air into the volume to be sterilized by a sterile connecting hose, a sterilization reagent import, a coupling clamp for the inlet ventilation pipe and an inlet HEPA filter. The sterilizing vapors escape from the interior of the isolator through two in series HEPA filters, a sterilizing agent by-pass tube, a sterilizing agent by-pass electronic control ball valve and an extraction blower to the exhaust export. The sterilization time using Soproper vapor is 12h for the interior chamber with 400cm(L)×120cm(W)×120cm(H) dimensions sterilization. *B. atrophaeus* spore strips placed in 13 critical locations of the isolator internal surface (such as DPTE α door, stainless-steel cages, glove-sleeve systems, the end of HEPA filter) were all destroyed.

Minnicare dry fog system is also a good disinfection device for breeding isolator. This system can be transferred into the isolator with 30% hydrogen peroxide in the reservoir. The nozzle allows for rapid vapor dispersion and ensures that the entire isolator space is exposed to dry fog when compressed air source connected with the dry fog system. The isolator is maintained under positive 750 Pa for 5 min, and then the isolator internal pressure allows natural attenuation to zero. All *Bacillus atrophaeus* spore strips placed in the isolator were inactive. Anyway the system always sprays out some large droplets at the beginning, then stride forward to 7.5 μm normal droplets. So it is still not be used for decontaminating equipments.

Hydrogen peroxide vapor technology used by BioQuell Z system has been developed to be the effective system available for rapid and secure biodecontamination of equipment and facilities. The anatomy isolator and micrurgy isolator and their internal equipments can be decontaminated simultaneity with the laboratory terminal disinfection. There are conditioning, gassing, dwell and aeration four phases as described by the Z manufacturers. The gassing time (T) can be calculated with the experience formula: $T = V \times 5 \text{ (g/m}^3\text{)} / 20 \text{ (g/min)}$, where V = room volume (m³). Apex Laboratories offered *Geobacillus stearothermophilus* spore stainless steel discs can be used for sterility testing by 30% hydrogen peroxide in isolator and its located room sterilization environments. The anatomy isolator

and micrurgy isolator are in the independent 63 m³ room respectively. The isolator negative pressure sets as -20 Pa. The lab ventilation is off, four desktop fans are on. The room temperature is 16°C, relative humidity is 40%~70%. Connected the Z well, and check area to be bio-decontaminated no people or animal. All doors and windows are shut and secured, and seal the door with tape. The gassing time sets as 15 min, dwell time sets as 25 min. The injection rate of hydrogen peroxide during dwell phase is 5g/min as to maintain the concentration necessary for decontamination. At the end of aeration, the concentration of hydrogen peroxide within the room is reduced down to zero, and the Z can be stopped. The total time is 8h for the isolator and its interior equipment and the room sterilization. *G. stearothermophilus* spore discs placed in 13 critical locations of the isolator internal surface (such as DPTE α door, stainless-steel frame of equipment, glove-sleeve systems, the bottom and surface of equipment, the end of HEPA filter) were all inactive. The black paint on the microscopy are disappear after 20 times of this kind of disinfection, but the other paints still keep well, and the optical system of microscope is also not affected.

8. Conclusions

The isolator systems achieve multiple technical improvements: (1) By using variable frequency drive blowers as the inlet air and extraction blowers, adjustments for rapid pressure changes (e.g., insertion of gloves) can occur automatically without breaching the inert atmosphere. The extraction blowers contain an integrated backup system with one blower running at full strength and another on standby to act as a backup. Negative or positive pressure states are kept stable and at a safe level through the automatic control system. The pressure is adjusted depending on different requirements for different animals and/or experimental conditions. (2) The control cabinet installation is comprised mainly of the programmable logic controller, electric element (which includes the voltage transformer, secure alternating current contactor, circuit breaker, electric cable, indicating lamp and button), network port (for data output) and industrial Ethernet interface (which allows for the remote data control of multiple isolation chambers by the WINCC 6.0 program system). Automatic control and monitoring of the isolation chamber and sterilization system are achieved by the exchange of data between the touch screen and control cabinet through the industrial bus Profibus DP to meet different laboratory animal research project parameter requirements such as pressure, humidity, temperature, illumination and disinfection. A human operator can set the isolation chamber environment parameters according to the requirements of the infectious animals or for cleaning animals, allowing for the acquisition of adequate and authentic data. (3) Animal welfare is ensured by installing adjustable illumination lamps, a rotatable camera, a flat television, a micro-differential pressure sensor and temperature humidity sensor to maintain comfortable living conditions for the animal.

9. Acknowledgements

This work was supported by the Natuional Natural Science Foundation of China (30972633).

10. References

World Health Organization, (2004). Laboratory biosafety manual, 3rd ed. World Health Organization, Geneva.

- Bantin GC. (2004). A comparison between the application of flexible film isolators and individual ventilated cages. *Shanghai Laboratory Animal Science*. 24(1):3-6.
- Wathes CM, Johnson HE. (1991). Physical protection against airborne pathogens and pollutants by a novel animal isolator in a level 3 containment laboratory. *Epidemiol Infect*. 107(1):157-170.
- Kruse RH, Puckett WH, Richardson JH. (1991). Biological safety cabinetry. *Clin Microbiol Rev*. 4(2):207-241.
- Huang R. (2005). Isolator of using negative pressure for big animals. CN Patent Publication number 1625942A.
- Pan X, Long M, Liang H, Chen X, Li H, Li GB, Zhao ZY. (2010). Development of a multifunction isolator system for the care of medium-sized laboratory animals harboring infectious diseases. *J Med Devices*. 4(4): 041004.
- Tattershall SF. 2006. Enclosure for handling hazardous material. US Patent No.: US7077486 B2.
- Sawyer J, Bennett A, Haines V, Elton E, Crago K, Speight S. (2007). The effect of microbiological containment systems on dexterity. *J Occup Environ Hyg*, 4(3):166-173.
- Clough G, Wallace J, Gamble MR, Merryweather ER, Bailey E. (1995). A positive, individually ventilated caging system: a local barrier system to protect both animals and personnel. *Lab Anim*. 29(2):139-151.
- Wathes CM, Johnson HE. (1991). Physical protection against airborne pathogens and pollutants by a novel animal isolator in a level 3 containment laboratory. *Epidemiol Infect*. 1991;107(1):157-70.
- ISO 14664-7:2004 · Cleanrooms and associated controlled environments —Part 7: Separative devices (clean air hoods, gloveboxes, isolators and minienvironments). International Organization for Standardization, Geneva.
- ISO 10648-1:1997, Containment enclosures — Part 1: Design principles. International Organization for Standardization, Geneva.
- Hillman P, Gebremedhin K, Warner R. (1992). Ventilation system to minimize airborne bacteria, dust, humidity, and ammonia in calf nurseries. *J Dairy Sci*. 75(5):1305-1312
- Institute of laboratory animal resources commission on life sciences, National research council. (1996). Guide for the care and use of laboratory animals. Washington, D.C: National Academy Press.
- Runkle RS, Allendale NJ, Marsh RC, Albuquerque NM. (1969). Unit for providing environmental control of animals. US Patent No.: 3630174.
- Allen JR, Burgess M, Aiken SC. (2009). Container lid gasket protective strip for double door transfer system. US Patent Pub.No.: US2009/0212054 A1.
- Michael A, Szatmary FT, Worth TX. (2004). Rapid transfer port. US Patent No.: US6779567 B1.
- Tauraso NM, Norris GF, Sorg TJ, Cook RO, Myers ML, Trimmer R. (1969). Negative-pressure isolator for work with hazardous infectious agents in monkeys. *Appl Microbiol*. 18(2):294-297.
- Pan X, Sun Y. (2004). Expression of SARS-CoV spike protein functional receptor ACE2 in human cornea and conjunctiva tissues. *High Technology Letters*. 10 (supplement): 273-277.

- Conly J, Johnston B. (2008). The infectious diseases consequences of monkey business. *Can J Infect Dis Med Microbiol.* 19(1):12-14.
- Pan X, Qi JC, Long M, Liang H, Chen X, Li H, Li GB, Zheng H. (2010). New technique: Development of a large-scale isolation chamber system for the safe and humane care of medium-sized laboratory animals harboring infectious diseases. *J Zhejiang Univ Sci B.* 11 (10): 771-778.
- GB50447-2008, Architectural and technical code for laboratory animal facility. National Standard. China.
- GB14925-2001, Laboratory animal- requirements of environment and housing facilities. National Standard. China.
- GB50346-2004, Architectural and technical code for biosafety laboratories. National Standard. China.
- EN 12469:2000, Biotechnology-Performance criteria for microbiological safety cabinets. European Standard. European Committee for Standardization.
- ISO10648-2:1994, Containment enclosures - Part 2: Classification according to leak tightness and associated checking methods. International Organization for Standardization, Geneva.
- GB19489-2008, Laboratories-General requirements for biosafety. National Standard. China.
- GB50591-2010, Code for construction and acceptance of cleanroom. National Standard. China.

IntechOpen

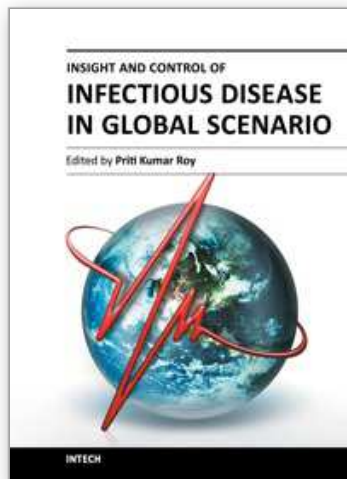

Insight and Control of Infectious Disease in Global Scenario

Edited by Dr. Roy Priti

ISBN 978-953-51-0319-6

Hard cover, 442 pages

Publisher InTech

Published online 21, March, 2012

Published in print edition March, 2012

This book is projected as a preliminary manuscript in Infectious Disease. It is undertaken to cover the foremost basic features of the articles. Infectious Disease and analogous phenomenon have been one of the main imperative postwar accomplishments in the world. The book expects to provide its reader, who does not make believe to be a proficient mathematician, an extensive preamble to the field of infectious disease. It may immeasurably assist the Scientists and Research Scholars for continuing their investigate workings on this discipline. Numerous productive and precise illustrated descriptions with a number of analyses have been included. The book offers a smooth and continuing evolution from the principally disease oriented lessons to a logical advance, providing the researchers with a compact groundwork for upcoming studies in this subject.

How to reference

In order to correctly reference this scholarly work, feel free to copy and paste the following:

Xin Pan (2012). Isolator System For Laboratory Infectious Animals, Insight and Control of Infectious Disease in Global Scenario, Dr. Roy Priti (Ed.), ISBN: 978-953-51-0319-6, InTech, Available from:

<http://www.intechopen.com/books/insight-and-control-of-infectious-disease-in-global-scenario/isolator-system-for-laboratory-infectious-animals>

INTECH
open science | open minds

InTech Europe

University Campus STeP Ri
Slavka Krautzeka 83/A
51000 Rijeka, Croatia
Phone: +385 (51) 770 447
Fax: +385 (51) 686 166
www.intechopen.com

InTech China

Unit 405, Office Block, Hotel Equatorial Shanghai
No.65, Yan An Road (West), Shanghai, 200040, China
中国上海市延安西路65号上海国际贵都大饭店办公楼405单元
Phone: +86-21-62489820
Fax: +86-21-62489821

© 2012 The Author(s). Licensee IntechOpen. This is an open access article distributed under the terms of the [Creative Commons Attribution 3.0 License](#), which permits unrestricted use, distribution, and reproduction in any medium, provided the original work is properly cited.

IntechOpen

IntechOpen