

We are IntechOpen, the world's leading publisher of Open Access books Built by scientists, for scientists

4,800

Open access books available

122,000

International authors and editors

135M

Downloads

Our authors are among the

154

Countries delivered to

TOP 1%

most cited scientists

12.2%

Contributors from top 500 universities



WEB OF SCIENCE™

Selection of our books indexed in the Book Citation Index
in Web of Science™ Core Collection (BKCI)

Interested in publishing with us?
Contact book.department@intechopen.com

Numbers displayed above are based on latest data collected.
For more information visit www.intechopen.com



Life Cycle Assessment of Organic Photovoltaics

Annick Anctil¹ and Vasilis Fthenakis^{1,2}

¹*Photovoltaic Environmental Research Center, Brookhaven National Laboratory*

²*Center for Life Cycle Analysis, Columbia University
USA*

1. Introduction

The unlimited abundance of solar resources ensures that photovoltaic technologies have the potential to supply a significant amount of the energy required to fulfill current- and future-energy demands while reducing greenhouse- gases emissions. So far, the high cost of photovoltaics compared to other energy sources has limited their use. However, emerging technologies, such as organic photovoltaics (OPV), which take advantage of man-made materials and solution processing, hold the promise for inexpensive devices. While solar cells could be an alternative to energy produced from fossil fuels, it is necessary to ensure that, in doing so, new environmental issues are not created. For this reason, life cycle assessments (LCAs) can be undertaken on emerging organic technologies to evaluate a priori the environmental impact of large-scale production and identify pathways toward sustainable energy production. In this chapter, the methodology of life-cycle assessment is presented, emphasizing photovoltaics usages, and is applied to emerging organic photovoltaics.

2. Life cycle assessment methodology

Life-cycle assessment (LCA) is a “cradle-to-grave” approach that begins with the extraction of the raw material (cradle), and ends when the material returns to the earth (grave). The cumulative environmental impacts from all stages in a product’s life cycle are included, so affording a comprehensive view of the environmental impacts, and allowing evaluations of trade-offs in product and process selection. By undertaking this comprehensive analysis, encompassing all product life cycle stages and multiple metrics, the LCA helps to avoid environmental problems.

LCA is a ISO standardized method that requires specific methodology. It consists of four stages, as illustrated in Fig. 1(b) (International Organization for Standardization 2006; EPA 2006), which are summarized as follows:

1. **Goal definition and scoping:** The product, process, or activity of interest is defined and described by establishing clear system boundaries and metrics. During this stage, the type of information required for the analysis, and how the results of the LCA should be interpreted and used must be included. Furthermore, the distinction between foreground and background data must be established. The foreground system is the system of primary concern, while the background system generally uses aggregated datasets that are similar for all the various scenarios being considered.

2. **Inventory Analysis:** All relevant data are collected and organized. The level of accuracy and detail will influence the quality of the analysis. The assumptions and limits of data collection must be clearly defined, such as cut-off rules. The goal and scope stage has defined general system boundaries that need to be further detailed and analyzed using the following four stages:
 - a. Develop a flow diagram of the processes being evaluated
 - b. Formulate a data-collection plan
 - c. Collect data
 - d. Evaluate and report results
3. **Impact Assessment:** The inventory information is used in combination with appropriate metrics to predict the potential human- and ecological-impacts.
4. **Interpretation:** Evaluate the results of the inventory analysis and impact assessment to select the preferred product, process or service.

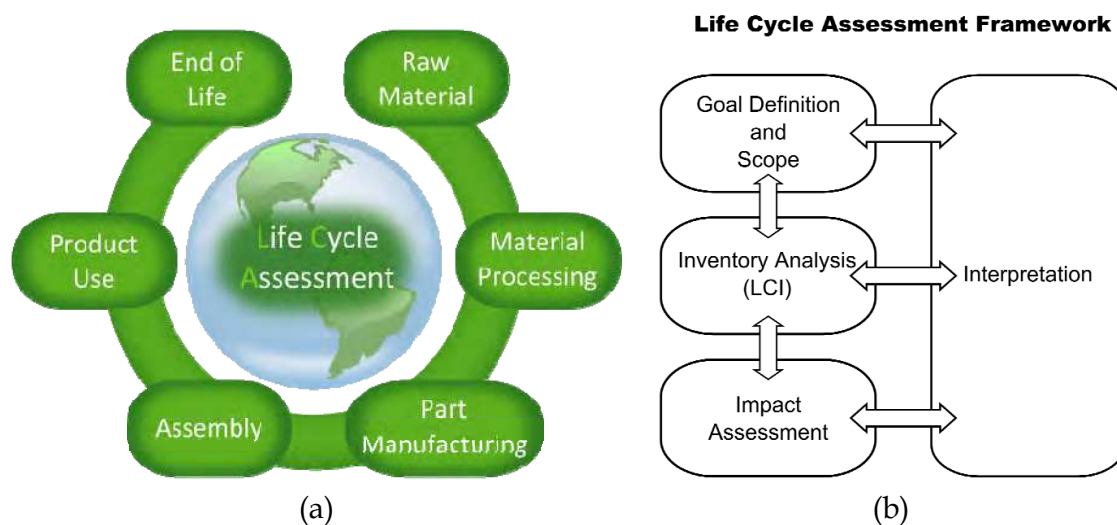

Fig. 1. (a) Cradle-to-grave Life Cycle Assessment and (b) LCA Framework according to ISO standards 14040 and 14044 (International Organization for Standardization 2006).

As illustrated in Fig. 1(b), the LCA process is iterative. For example, interpretation is undertaken throughout the process and each stage is reevaluated, based on the results obtained. There is a variety of commercial software that can be used for life-cycle assessment to simplify the compilation and analysis of data. The software also contains life-cycle-inventory (LCI) databases for various chemicals and processes that generally are used to model the background system.

The ISO- and EPA-standards afford a framework for an LCA. However, this framework offers the individual practitioner a range of choices that can affect the validity and reliability of the results. To ensure consistency between photovoltaics (PV) LCA studies, the IEA recently published guidelines (Fthenakis et al., 2011). They represent a consensus among PV-LCA experts in North America, Europe, and Asia, for assumptions about PV performance, process input, and emissions allocation, methods of analysis, and reporting of the findings. The document offers guidance on photovoltaic-specific parameters (e.g., life expectancy, irradiation, performance ratio, degradation) that are the inputs in LCA, on choices and assumptions in analyzing data on life-cycle inventory (LCI) data, and on implementing modeling approaches.

The IEA Guidelines specially emphasize reporting transparency. This is of the utmost importance as parameters vary with geographical zones, and a system's boundary conditions and modeling approach can affect the findings significantly. At a minimum, the following parameters should be reported (Fthenakis et al., 2011): 1) On-plane irradiation-level and location; 2) module-rated efficiency; 3) system's performance ratio; 4) time-frame of data; 5) type of system (e.g., roof-top, ground mount fixed tilt or tracker); 6) expected lifetime for PV and BOS; 7) system's boundaries (whether capital goods, installation, maintenance, disposal, the transportation- and recycling-stages are included for both PV modules and balance-of-system (frame, mounting, cabling, inverter; for utility applications the transformer, site preparation, and maintenance)); 8) the place/country/region of production modeled, and, 9) the study's explicit goal.

These parameters should be listed in the captions of figures showing the results of the LCA. In addition, the report should identify the following: The LCA method used, especially if is not process-based; the LCA tool; databases used; the method of calculating the energy-payback time; the commercial representativeness of the study; and, assumptions on the production of major input materials.

2.1 Metrics

The following metrics are suggested for undertaking an impact assessment of PV LCA.

- **Greenhouse gas emissions:** The greenhouse gas (GHG) emissions during the life cycle stages of a PV system are estimated as an equivalent of CO₂, using an integrated 100-year time-horizon that incorporates the ICPP's most recently published global-warming potential factors.
- **Cumulative Energy Demand (CED):** The CED describes the consumption of fossil-, nuclear-, and renewable-energy sources throughout the life cycle of goods or services. This includes the direct uses and as the indirect (grey) consumption of energy due to employing materials (e.g. plastic or wood in construction), the consumables necessary in manufacturing (e.g., solvents, gloves, packaging), and the raw materials. The simplicity of concept of a CED assessment assures that it is a good starting point for an assessment, along with and its comparability with CED results in other studies. The following two CED indicators are well known: CED, non-renewable [MJ-eq.] – fossil and nuclear and CED; and, renewable [MJ-eq.] – hydro, solar, wind, geothermal, biomass.
- **Acidification potential (AP):** Acidification describes a change in acidity in the soil due to atmospheric deposition of sulphates, nitrates, and phosphates. Major acidifying substances are NO_x, NH₃, and SO₂.
- **Ozone-depletion potential (ODP):** The thinning of the stratospheric ozone layer as a result of anthropogenic emissions is described by the stratospheric ozone-depletion indicator. The impacts potentially are harmful to human health, animal health, terrestrial- and aquatic-ecosystems, biochemical cycles, and materials.
- **Human toxicity:** This indicator covers the impacts of toxic substances on human health. The health risks of exposure in the workplace also can be included.
- **Ecotoxicity:** This indicator includes the impacts of toxic substances on aquatic-, terrestrial-, and sedimentary-ecosystems.
- **Land use and water use:** These are environmental impacts are of growing importance. Recommendations are to list separately the withdrawal and consumption of water, and the occupation and transformation of land.

2.2 LCA interpretation

Considering that the main objective of using solar PV is to reduce the environmental impact associated with the employing fossil-fuel energy resources, the recommendations (Fthenakis et al., 2011) are to include specific indicators, such as the energy payback time (EPBT), the nonrenewable energy payback time (NREPBT), the energy return on investment (EROI), and the impact mitigation potentials (IMP).

2.2.1 Energy Payback Time (EPBT)

The EPBT denotes the time needed to compensate for the total renewable- and non-renewable- primary energy required during the life cycle of a PV system. The annual electricity generation (E_{agen}) is converted into its equivalent primary-energy, based on the efficiency of electricity conversion at the demand side, using the current average (in attributional LCAs), or the long-term marginal grid mix (in decisional/consequential LCAs) where the PV plant is being installed.

$$\text{EPBT} = (E_{\text{mat}} + E_{\text{manuf}} + E_{\text{trans}} + E_{\text{inst}} + E_{\text{EOL}}) / ((E_{\text{agen}} / \eta_{\text{G}}) - E_{\text{O\&M}}) \quad (1)$$

where,

E_{mat} : Primary energy demand to produce materials comprising PV system

E_{manuf} : Primary energy demand to manufacture PV system

E_{trans} : Primary energy demand to transport materials used during the life cycle

E_{inst} : Primary energy demand to install the system

E_{EOL} : Primary energy demand for end-of-life management

E_{agen} : Annual electricity generation

$E_{\text{O\&M}}$: Annual primary energy demand for operation and maintenance

η_{G} : Grid efficiency, the average primary energy to electricity conversion efficiency at the demand side

2.2.2 Non-renewable Energy Payback Time (NREPBT)

The NREPBT denotes the time needed to compensate for the non-renewable energy required during the life cycle of a PV system. It accounts for only the non-renewable primary energy; renewable primary energy is *not* accounted for, neither on the demand side, nor during the operation phase. The annual electricity generation (E_{agen}) likewise is converted to the primary energy equivalent, considering the efficiency of the non-renewable primary energy to electricity conversion of the grid mix where the PV plant is being installed. The formula of NREPBT is identical to that of the EPBT given above except replacing “primary energy” with “non-renewable primary energy”. Accordingly, grid efficiency, η_{G} , accounts for only non-renewable primary energy.

Both EPBT and NREPBT depend on the grid mix; however, excluding the renewable primary energy makes NREPBT more sensitive to local- or regional- conditions (e.g., product-specific use of hydro-power) that which may not be extrapolated to large global scales. On the other hand, the EPBT metric with an average large-scale grid-conversion efficiency (e.g., EU, or US, or World) might not capture the conditions of local- or regional-conditions. The calculated EPBT and NREPBT do not differ significantly in cases wherein the power plant mix of a country or region is dominated by non-renewable power generation. However, as an increasing share of renewable energies is expected in future power-grid mixes as well as within the PV supply- chain, the two opposing effects of a

reduction in the CED of PV, and an increase in grid efficiency will require careful consideration, hence, the numerical values of EPBT or NREPBT may vary considerably according to the chosen approach.

2.2.3 Energy Return on Investment (EROI)

The traditional way of calculating the EROI of PV is as follows (Reich-weiser, Dornfeld, and Horne 2008):

$$\text{EROI} = \text{lifetime} / \text{EPBT} = T \cdot ((E_{\text{agen}}/n_G) - E_{\text{O\&M}}) / (E_{\text{mat}} + E_{\text{manuf}} + E_{\text{trans}} + E_{\text{inst}} + E_{\text{EOL}}) \quad (2)$$

2.2.4 Impact Mitigation Potentials (IMP)

This may comprise the mitigation potentials for climate change and high-level nuclear waste (Jungbluth et al., 2008). Clearly reference the impact assessment method applied, and specify the reference system, e.g., today's European electricity mix, or the national electricity supply mix.

3. Organic photovoltaics

While 20 years of research were necessary to increase device power efficiencies from 0.1 to 3.5% in 2005 (Janssen, Hummelen, and Sariciftci 2005), the last five year have seen unprecedented interest in the technology, so resulting in a rapid increase in efficiency up to 8.3% for both small molecule- and polymer-photovoltaics (Green, Emery, Hishikawa, Warta, et al. 2011). Compared to other photovoltaics technologies, commercialization occurred earlier than expected by Konarka (polymers) and Heliatek (small molecules) since the potential for inexpensive new applications counterbalance their low efficiency. For example, incorporating low-efficiency organic solar cells in electronic products has the advantage of increasing the lifetime of the battery since it is being charged by ambient lighting while not in use. Smart fabrics (also referred to as wearable technology) add new functionality to traditional applications, for example, in clothing, tents, and military uniforms. Applications are numerous for off-grid remote locations, in particular to provide lighting at night, or play a double role in shading an area while supplying electricity for another usage, for example, shade structures. The area where organic photovoltaic is expected to have the largest impact is in building-integrated photovoltaics (BIPV). The low absorption of organic films supports light reduction while providing power for the building during the day when demand is at its peak. Compared to traditional semiconductors, organic molecules offer a considerable improvement in design since they s can be tuned to the desirable colors by slightly changing their chemical properties, thereby allowing solar- cells to be an integral part of the design.

The most common device structure for OPV uses a mixture of donor- and acceptor-materials referred to as a bulk heterojunction (BHJ) that resides between two electrodes. Fig. 2 (a) illustrates a typical BHJ made of Poly (3-hexylthiophene) (P3HT) and Phenyl-C₆₁-butyric- acid methyl ester (C₆₀PCBM). As depicted, the photovoltaic effect follows the following steps: the illumination of an organic semiconductor donor (1) generates excitons (2) with a binding energy of about 0.4 eV instead of free charges (Hadipour, de Boer, and Blom 2008). To separate into free charges, the exciton must diffuse until it reaches a donor/acceptor interface (3) with a difference in electron affinities and an ionization potential large enough to overcome the binding energy. The energy cascade required for

charge extraction is illustrated in Fig. 2(b). The free charges then can travel (4) through either the donor- or acceptor- material (5), and then are collected at the electrodes (6). The overall efficiency of the device therefore is determined by the optical absorption and the efficiency of each of those steps.

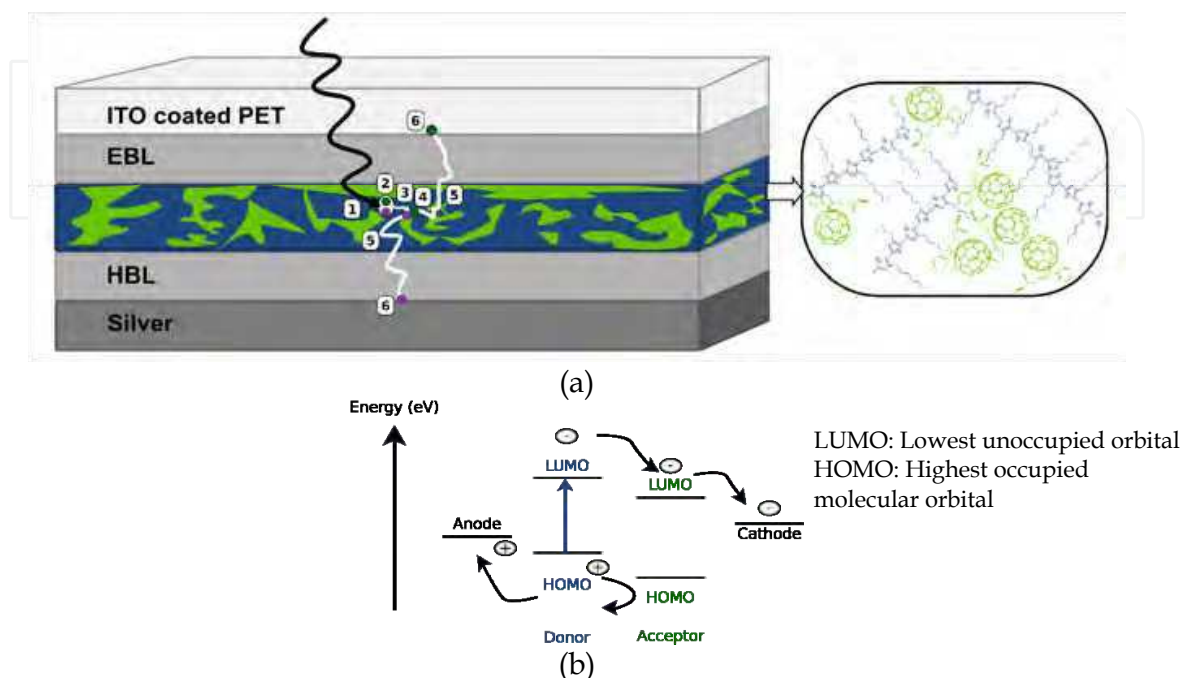

Fig. 2. (a) Photovoltaic effect in a bulk heterojunction organic solar cell with details about the chemical structure of P3HT:C₆₀PCBM material used in the active layer; (b) conditions for charge transfer in a donor/acceptor photovoltaic device where the colors correspond to the donor and acceptor molecules illustrated in (a).

Various challenges have limited the use of OPV; in particular, the large bandgap of most organic polymers is responsible for low power-conversion efficiency because a large portion of the solar spectrum is unabsorbed. In theory, in an optimal solar cell, the acceptor bandgap should be around 1.4 eV, wherein the maximum efficiency would be 31% under 1 sun AM1.5 (Gregg 2011). Most early-generation semiconducting polymers, such as polythiophenes, have bandgaps higher than 2- eV (620 nm), so limiting their maximum efficiency. There are two main alternatives to increase the devices' efficiency: Lowering the bandgap to absorb a maximum of photons in one layer, or using a multi-junction approach where two different materials absorb in a different region of the solar spectrum.

The low bandgap approach has received considerable interest in the last few years and allowed the current record efficiency for polymer devices. By lowering the bandgap from 2eV to 1.5 eV, the maximum theoretical efficiency increases from 8% to 13% (Siddiki et al. 2010). To increase efficiencies further, the multi-junction approach, illustrated in Fig. 3 is necessary. For OPV this approach is not only advantageous to capture a broader range of the solar spectrum, but it also helps overcome the poor charge carrier mobility and lifetime of carriers which prevents the fabrication of a thick absorbing layer (Ameri and Al. 2009). In comparison with inorganic material, organic semi-conductors absorb only a narrow portion of the spectrum as illustrated in Fig. 3 and therefore a combination of multiple materials is necessary to absorb a larger portion of the spectrum.

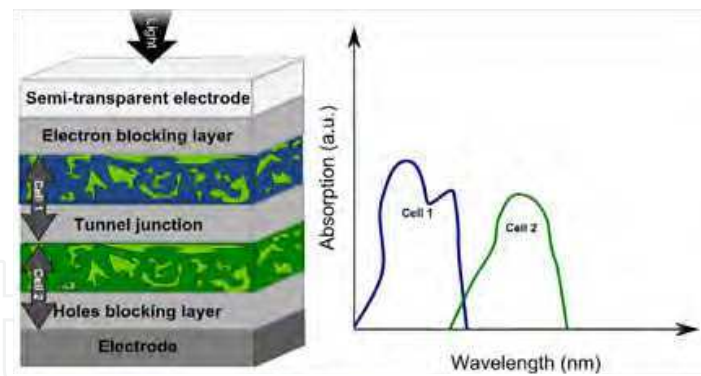

Fig. 3. Organic photovoltaic with two sub-cells having different complementary absorption-spectra.

Multi-junction devices either can be connected in series or in parallel depending on the nature of the intermediate layer. The most common type of connection is in series wherein the voltage across the whole device is equal to the sum of the voltage of each sub-cell, and the current is limited by the lowest sub-cell current. While multi-junction devices increase efficiency, they also increase the device's complexity and require additional processing steps and materials.

In addition to the problem of photon absorption, another issue for organic photovoltaics is charge recombination where free charges recombine before reaching the electrodes (step 4 in Fig. 2). One option that was shown to be effective is to use a hole-blocking layer, such as titanium dioxide (TiO_x) before depositing the metallic electrode (Hayakawa et al. 2007).

4. Life-cycle assessment of organic solar cells

There are some early evaluations of the life-cycle impact of producing organic photovoltaics, but all recent studies were limited to single-junction polymer devices (Roes et al. 2009; García-Valverde, Cherni, and Urbina 2010; Espinosa et al. 2010), i.e., the best types of devices five years ago, but since, have been surpassed. As described in the previous section, there are various alternatives types of photovoltaics devices, including small molecule- and multi-junction- ones that have not been rigorously studied using LCA.

Furthermore, the few existing LCAs of organic PV were constrained by the unavailability of life-cycle inventory data, (i.e., materials and energy inputs and emissions and waste outputs over the life cycle of the cells and processes) because these 3rd-generation PV technologies are in R&D or in pilot-scale status. When direct, detailed inventory data from industrial production are unavailable, such studies often adopt data from laboratory-scale- or prototype-production, and from literature on similar process products, or their own modeling; sometimes this information is extrapolated or adjusted to describe the nanotechnologies studied. Accordingly, the LCAs of organic technologies inherently carry large uncertainties. For example, some of them include in their system boundary a large amount of solvents used in synthesizing and purifying nanomaterials, which is common under R&D conditions. However, fully scaled-up nanotechnologies would utilize them much more efficiently through recycling, energy recovery, or improved processes. We can expect that process yields in the former conditions will be much poorer than in scaled-up production lines.

Therefore, there is a need to develop realistic LCI data to study the life-cycle impacts of OPV technologies. The first step is to compile an LCI data-base for characterizing the impact of

individual new materials, including various donor materials (polymers and small molecules) and acceptors (fullerenes and derivatives) as well as materials used as electron- and hole-blocking layers (PEDOT:PSS and TiO_x, respectively). Using the results from these material inventories, the impact of various configurations of devices can be calculated.

The LCA results are obtained from analyses using SimaPro[®] based upon existing inventory data obtained from available databases and previously published primary literature. Inventory data for chemicals not available in databases are estimated using default values and stoichiometric reactions according to previously published guidelines (Frischknecht et al. 2007; Geisler, Hofstetter, and Hungerbühler 2004). The life-cycle impact of OPV was assessed using specific data from the life cycle of fullerene production, semiconductor polymer-, small molecule-, and interfacial material-processing. Different donor/acceptor combinations are examined in conjunction with the reported efficiencies and specific processing conditions. The life-cycle assessment is characterized via the cumulative energy demand (CED) method, using the Ecoinvent electricity profile for the United States. The CED was shown to be correlated with most environmental indicators (Capello et al. 2009; Huijbregts et al. 2006), and, since comprehensive data on environmental impact are scarce in current inventories, in particular on emissions in terms of their toxicology and releases, this approach often yields a better estimate of the environmental impact.

The Life Cycle of PV typically consists of materials production, solar cell- and PV module-manufacturing, installation, operation and maintenance, recycling and end-of-life (Fig. 4). The LCA of PV systems will be based on the life-cycle inventories of materials and energy for the solar cells, PV modules, and the balance of system (e.g., wiring, frames, inverters, support structures).

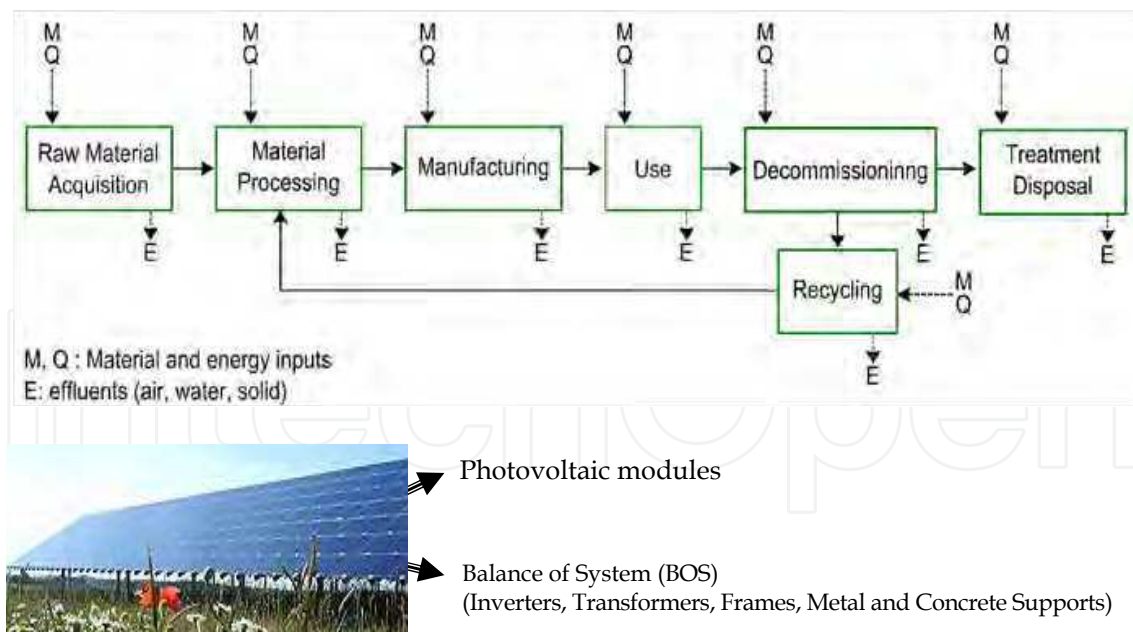

Fig. 4. The Life Cycle of Photovoltaic Systems.

LCI data on the cell/module manufacturing stages when possible, are obtained directly from the PV manufacturers and are documented with actual records of material inventories and energy use. The energy/emissions background data for the U.S. electricity mixture are obtained from established databases.

4.1 Life cycle inventory of materials for organic photovoltaics

4.1.1 Fullerenes and fullerene-derivatives

For OPV, the most common acceptor molecules are fullerenes for which there exists no detailed inventory information in particular with regard to the purity and chemical modifications required for application in organic photovoltaics. The methano-fullerene derivatives such as those illustrated in Fig. 2(a) are commonly used as an acceptor molecule when mixed with a conducting polymer to create a bulk heterojunction of donor/acceptor material in organic solar cells. The contribution from nanomaterials in developing products has generally not been thoroughly studied since there is a belief that a small amount of nanomaterials in a product will result in minimal environmental impact (Meyer, Curran, and Gonzalez 2009; Som et al. 2010). Whereas previous studies have limited the LCA scope to direct energy input (e.g. electricity usage) during fullerene synthesis (Roes et al. 2009; Kushnir and Sanden 2008) this study quantifies total material intensity and embodied energy with a scope that includes all direct and upstream feedstock and fuel energy inputs for modern production methods as illustrated in Fig. 5.

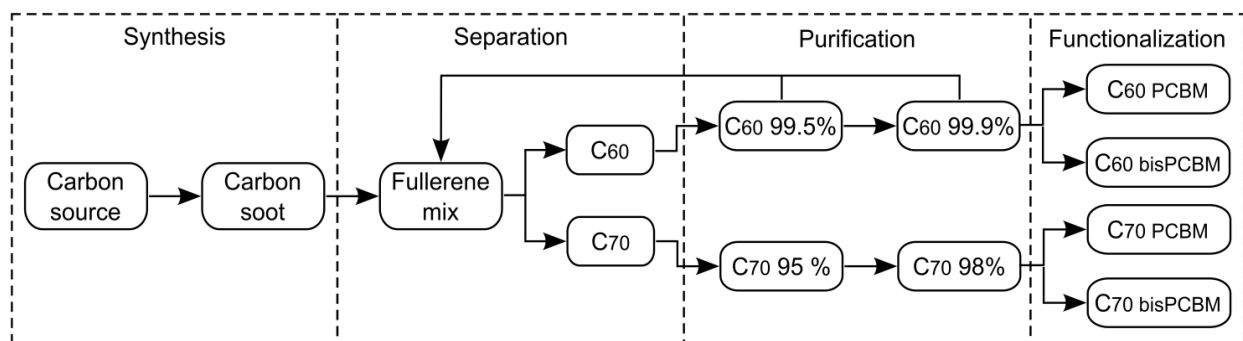

Fig. 5. Overview of the process flow for producing modified fullerene compounds for use as functional materials in organic solar cells (Anctil et al. 2011).

We specify the variation in synthesis methods and purification processes to more accurately quantify the impact from factors as the synthesis reaction, the purity of reactants and solvents, low reaction yields, repeated purification steps, and toxic chemicals or solvents. Four different methods are compared, using the conditions for synthesis summarized in Table 1. In general, pyrolysis techniques produce large amounts of various sized fullerenes, while the plasma techniques generate smaller quantities of mainly C₆₀. Plasma methods result an incomplete combustion process, and therefore, the main product is gaseous emissions while the soot containing the fullerenes is a secondary product per mass.

From this analysis, pyrolysis methods seemingly have an order-of-magnitude lower impact than does plasma, as illustrated for C₆₀ in Fig. 6. Detailed contributions for each method are given in Fig. 6(b). Electricity is the dominant contributor for plasma methods, while the carbon feedstock (either toluene or tetralin) are most important ones for pyrolysis. RF plasma has been developed to increase the production rate of fullerenes compared to arc plasma: accordingly, a larger amount of gas is required to provide sufficient energy to convert the carbon precursor into fullerenes.

Process	Carbon source	Fullerene yield in soot (%)	Production rate (g fullerene/hr)	Ratio C ₆₀ /C ₇₀ /higher fullerenes	Ref.
Arc Plasma	High purity graphite electrodes	13.1	1.2	69 / 24 / 7	(Marković et al. 2007)
Pyrolysis	Toluene	17.5	44	43 / 28.5 / 28.5	(Alford et al. 2008)
	Pyrolysis 1,4-tetrahydro-naphthalene (tetralin)	30	70	39 / 30.5 / 30.5	(Alford et al. 2008)
RF Plasma	Graphite powder	5.9	2.7	70 / 23 / 7	(Szépvölgyi et al. 2006)

Table 1. Reported values for fullerene production under different conditions of synthesis used to perform the LCA of fullerenes.

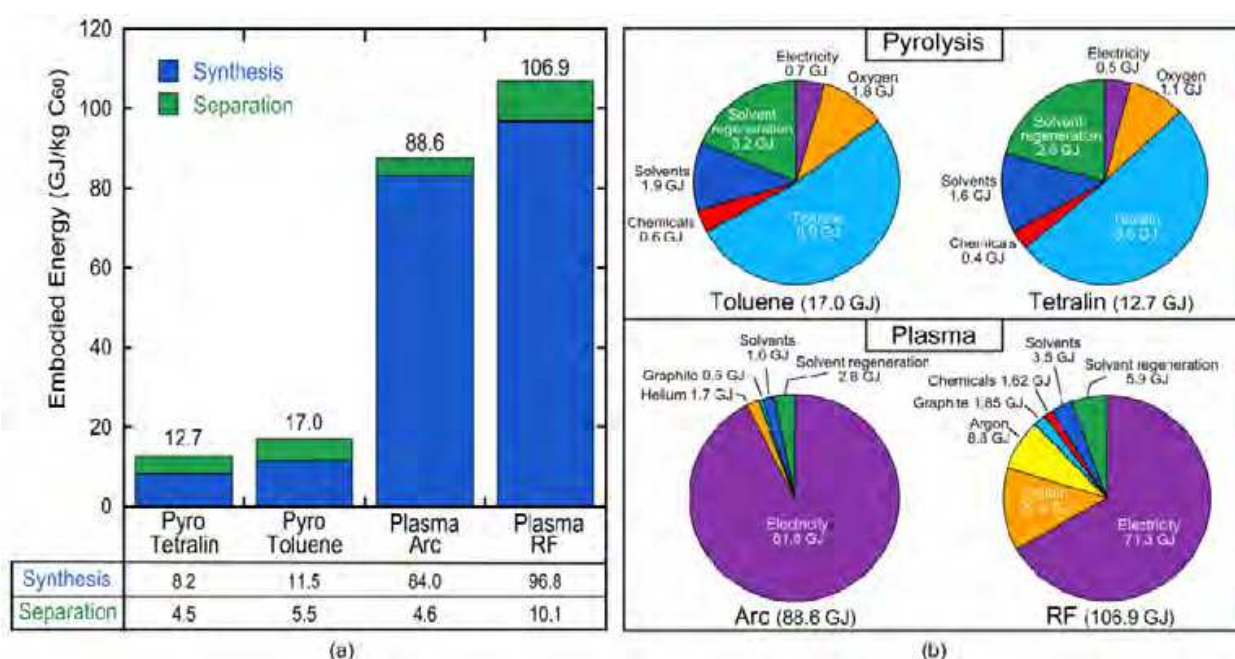

Fig. 6. (a) Embodied energy of 1 kg of C₆₀ after synthesis and separation, as produced by pyrolysis (tetralin and toluene) and plasma methods and (b) contribution of various components for the total embodied energy for each type of synthesis methods after fullerenes separation (Anctil et al. 2011).

The production of fullerenes is energy intensive because they account for less than 30% of the material generated during the synthesis stage, the rest being soot. Since fullerenes have low solubility, a large amount of solvent is required during separation and purification stages as illustrated in Fig. 7 for both C_{60} and C_{70} , considering the best-case scenario (pyro-tetralin). The electronic-grade material (grey region) in Fig. 7 corresponds to the material purity required for electronic applications.

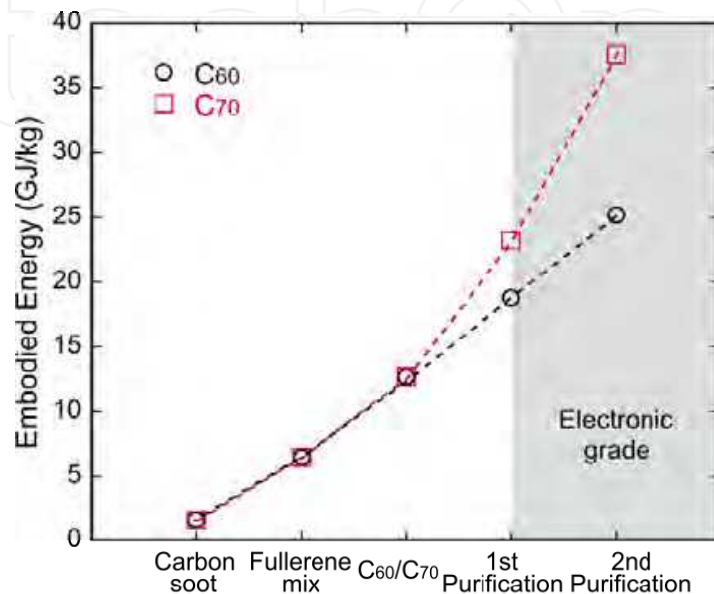

Fig. 7. Embodied energy for C_{60} and C_{70} products as a function of product stage (Anctil et al. 2011).

C_{70} is produced along with C_{60} in the carbon soot for each of the synthesis methods, albeit in ratios varying relative to the synthesis technique. Since C_{70} is more difficult to separate from the other higher order fullerenes than C_{60} , about 50% more C_{70} is required after separation to produce the same amount of high purity material.

While a high degree of purity is required for most electronic applications, in certain cases there is an additional need to modify the fullerene structure. This is the case for fullerenes used in organic solar cells which need to have high purity to avoid impurity trap states, but also need to be modified to PCBM to increase solubility for solution processing and device viability. The additional embodied energy associated with each of the various chemicals, solvents, and solvent regeneration steps further increases the embodied energy up to 64.7 GJ/kg for C_{60} -PCBM; more than five-fold greater than embodied energy calculated for C_{60} produced by pyro-tetralin. Although considerable research has utilized C_{60} -PCBM for organic solar cells, recent results show that C_{70} -PCBM produces higher efficiency devices (Liang et al. 2009) thereby increasing interest in the larger fullerenes. Fig. 8 illustrates the contribution from each component along the complete process required to produce either 1 kg of C_{60} -PCBM or C_{70} -PCBM. Due to the increased energy intensity associated with purification and the functionalization reactions, the embodied energy of C_{70} -PCBM is 90.2 GJ/kg as compared to 64.7 GJ/kg for C_{60} -PCBM. Therefore, each modified fullerene has a significantly different embodied energy, which in turn influences the embodied energy of the organic solar cell.

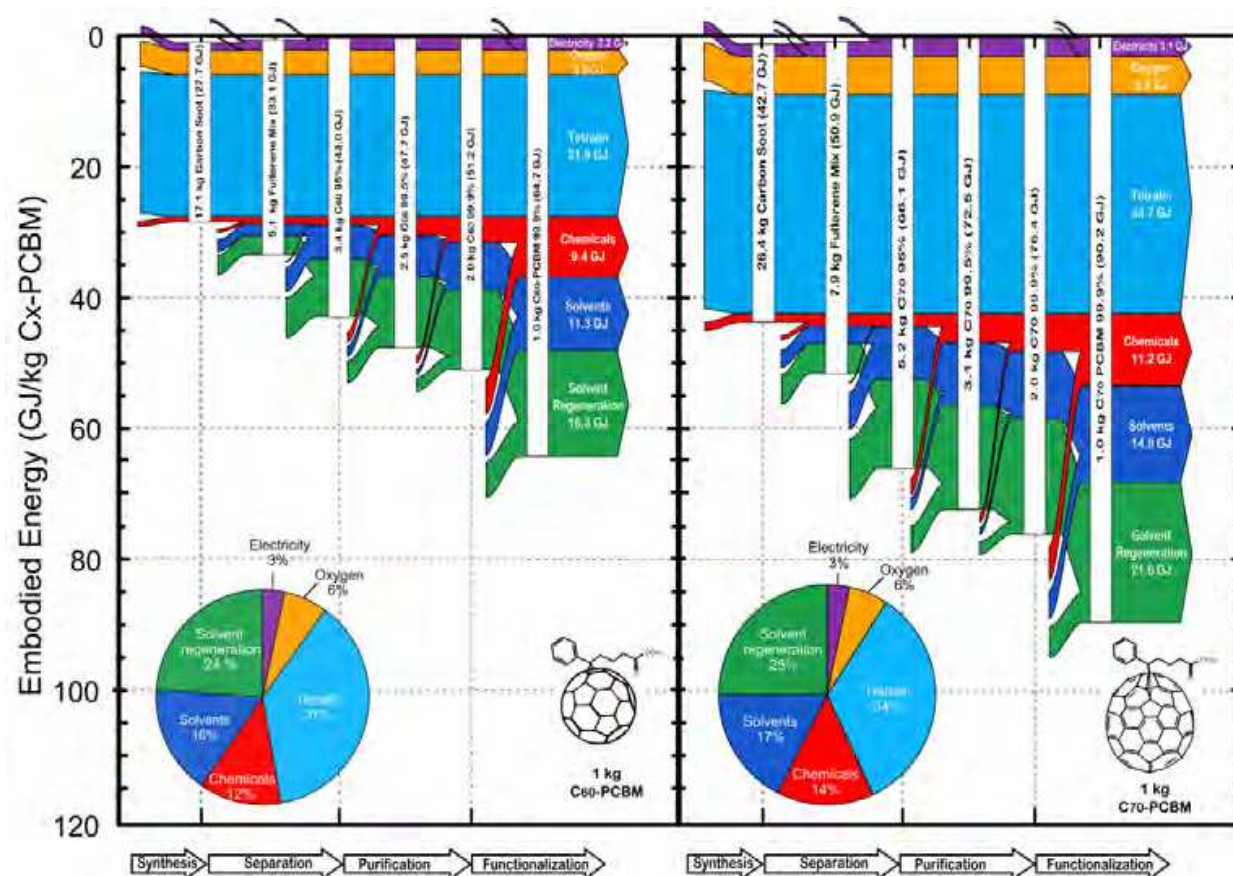

Fig. 8. Energy flow diagram for production using the pyro-tetralin synthesis method of (a) 1 kg of C₆₀PCBM, compared to (b) 1kg of C₇₀PCBM (Anctil et al. 2011).

4.1.2 Polymers and small molecules

Organic semiconductors require alternating single- and double-carbon bonds where each carbon binds only to three adjacent atoms, leaving one electron in the P_z orbital. The overlap of these P_z orbitals causes the formation of π bonds along the backbone, and the delocalization of the π electrons. Molecules with a delocalized π electron system can absorb sunlight, photo-generate charge carriers, and transport these charge carriers. The organization of the semi-conducting material is critical as the π - π bonds must be close enough to allow charge transport. Organic semiconductors fall into two categories: Polymers that can be solution-processed; and, small molecules that are generally evaporated under high vacuum.

Current interest in OPV can be attributed to regioregular poly(3-hexylthiophene) (P3HT) that allowed the efficiencies of devices to reach 5% for the first time. Morphology was critical, requiring precise control over the donor :acceptor ratio, the choice of solvent, and post-treatment annealing to induce the reorganization and crystallization of the polymer. In addition to P3HT, there is a significant interest in small molecules, in particular phthalocyanine molecules that already produced inexpensively in large amounts, mainly for pigments in paints and other products (Lambourne and Strivens 1999). In Fig. 9 depicts the energy required to produce 1 mol of various polymers and small molecules. For the polymers, increasing the number of steps from 4 for P3HT, to 9 for the low bandgap PCDTBT significantly impact the final embodied energy. Even if only 3 steps required for

small molecules, there is a rapid increase in embodied energy as 4 moles of the starting material is required to produce 1 mole of phthalocyanine.

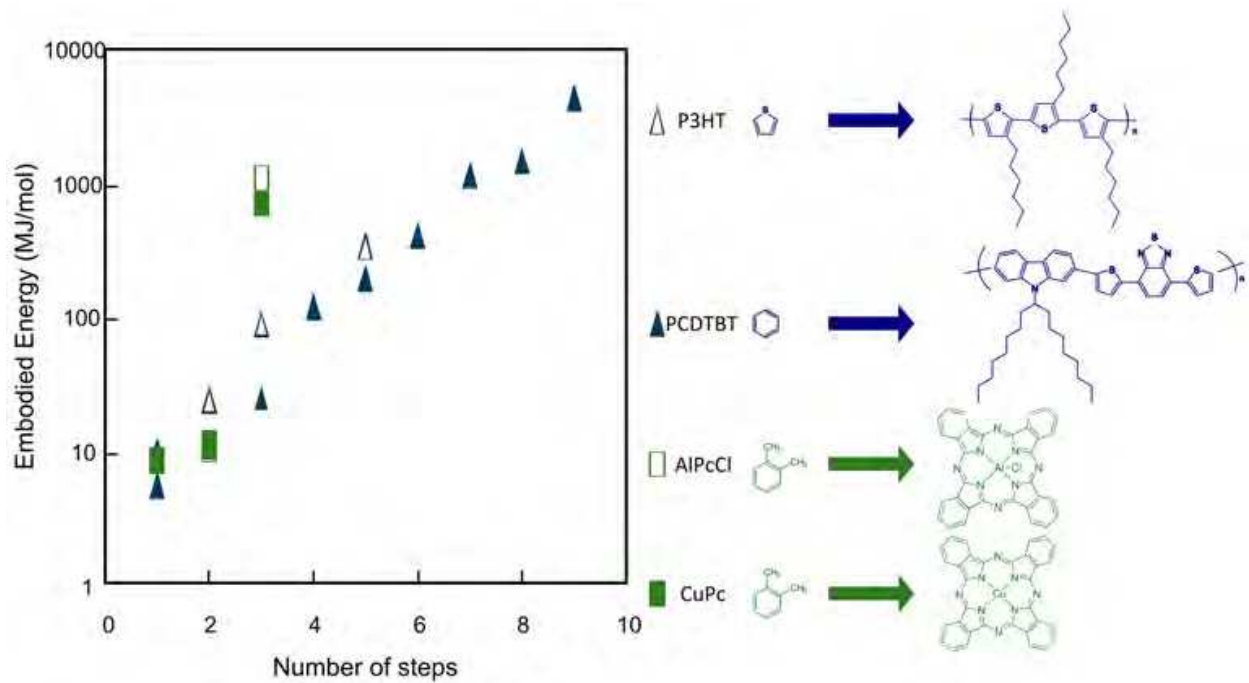

Fig. 9. Comparison of embodied energy in synthesizing of two types of phthalocyanines small molecules (green) and polymers (blue).

In addition to the active layer material (fullerenes, polymer, and small molecules) the impact of blocking layers used to improve charge collection is calculated. The results from all LCIs of materials used for organic photovoltaics considered in this work are illustrated in Fig. 10.

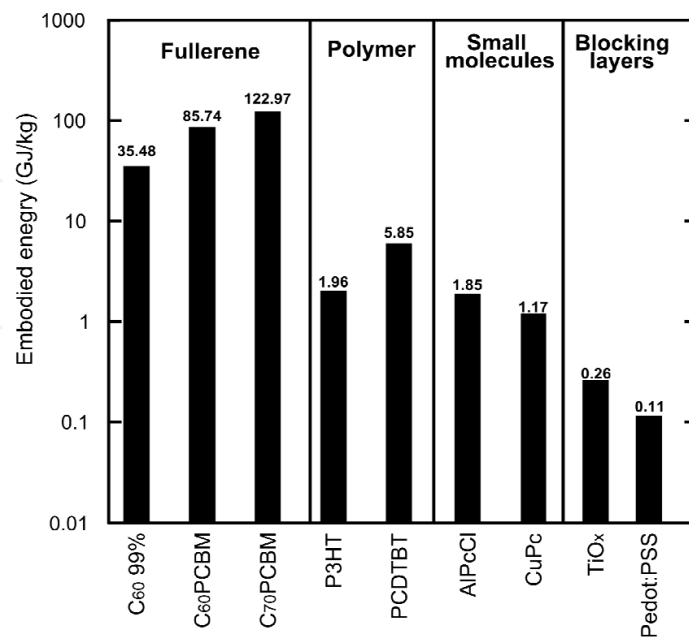

Fig. 10. Cumulative energy demand (CED) for various materials commonly used in organic photovoltaics.

As illustrated, C_{70} PCBM has the highest embodied energy, followed by both functionalized- and unmodified- C_{60} . The embodied energy of all fullerenes are an order-of-magnitude higher than most common chemicals, and therefore, are likely to influence the embodied energy of the product they will be used in, even though they might only represent a small fraction of its total mass. While low bandgap polymer PCDTBT requires larger amount of energy compared to AlPcCl or CuPc, this is significantly lower than other materials. Finally, the blocking layers are the least energy-intensive materials to produce.

4.2 Life-cycle impact of polymer, small molecules, and multi-junction organic photovoltaics

The primary goal of this LCA is to compute the CED of various organic photovoltaic technologies, including single-junction small molecule- and polymer-photovoltaics as well as their multi-junction counterparts that are responsible for the rapid increase in the devices' efficiency. A secondary goal is to examine the effect of specific processing conditions, such as using thermal treatments, interface layers, low bandgap polymers, and the type of heterojunction. Fig. 11 illustrated the systems considered. The functional unit of this study is the CED to produce a power of 1 watt-peak (CED/Wp).

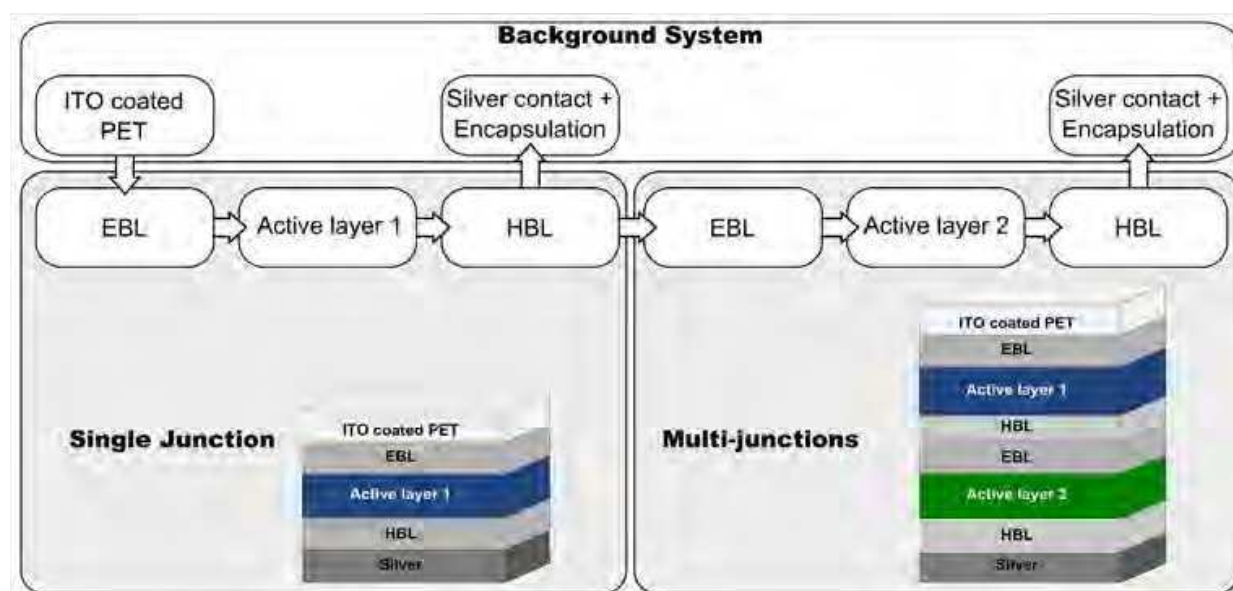

Fig. 11. System boundaries for both types of organic photovoltaic devices considered in this work.

Since the focus of this work is the active and interfacial layer material as well as the process energy associated with the deposition and annealing of those layers, the substrate (ITO coated PET), silver contact, and encapsulation constitute the background system (Fig. 11). The properties of those different components are described in Table 1.

Using the results from the previous section, the life cycle assessment (LCA) of various polymers, small molecules, single- and multi-junction-photovoltaics, representing various types of organic photovoltaics devices developed recently is calculated according to the fabrication conditions described in Table 2, including material ratio, layer thicknesses, and annealing conditions.

Stage	Details	Embodied Energy (MJ/m ²)	Reference
ITO-coated PET	Polyethylene terephthalate film (130 um thick)	16.9	(PlasticsEurope 2010)
	Sputtering 180 nm ITO (including production ITO)	68.3	(Hischier et al. 2007)
Contacts Printing	Silver	4.9	(Espinosa et al. 2010)
	Screen-printing	9.9	
Encapsulation	PET Covers + epoxy	11.7	
	Lamination energy	0.1	

Table 2. Values used for materials and energy commodities for the background system used in the inventory analysis.

Figure 12 summarizes the results of the LCA for both polymer- and small molecule-photovoltaics as a function of materials, processing, and other components. In general, the CED spans the same magnitude of 3-6 MJ/Wp for both cases. Also, the CED shows a trend of decreasing value with the device's increasing efficiency. The CED/Wp of small molecule devices is on average slightly higher than that of polymer devices, but this is largely due to the lower efficiency of the latter for reported measurements.

Device name	Efficiency (%)	Type	Reference
P3HT:C ₆₀ PCBM	5.0	Single junction polymer	(Ma et al. 2005)
PCDTBT: C ₇₀ PCBM	5.5	Single junction low-bandgap polymer	(Park et al. 2009)
PCDTBT:C ₇₀ PCBM - TiO _x	6.1	Single junction low-bandgap polymer with electron blocking layer	(Park et al. 2009)
P3HT:C ₇₀ PCBM+ PCDTBT: C ₆₀ PCBM	6.5	Multi-junction polymer	(Jin Young Kim et al. 2007)
AIPcCl:C ₆₀	3.0	Small molecules	(Cheyons, Rand, and Heremans 2010)
CuPc:C ₆₀	5.0	Small molecules	(Xue et al. 2005)

Table 3. Organic photovoltaics-devices considered herein, representing a variety of organic photovoltaic technologies, including single-junction small molecule- and polymer-photovoltaics, as well as their multi-junction counterparts.

Fig. 12 also illustrates a difference between polymer- and small molecule-photovoltaics in terms of the relative contribution from materials, processing, and other components. For the polymer devices, the material contributions dominate the processing conditions, whereas the opposite trend applies to small-molecule devices where they are more balanced. For example, the total thickness of a small-molecule photovoltaic is lower (<60 nm) than that of the polymer photovoltaic, and these structures utilize pure C₆₀, which has a dramatically lower embodied energy than the modified fullerenes in the polymer devices. Polymer photovoltaics need a thicker layer (e.g., 80-250 nm), requiring a larger amount of material of higher energy.

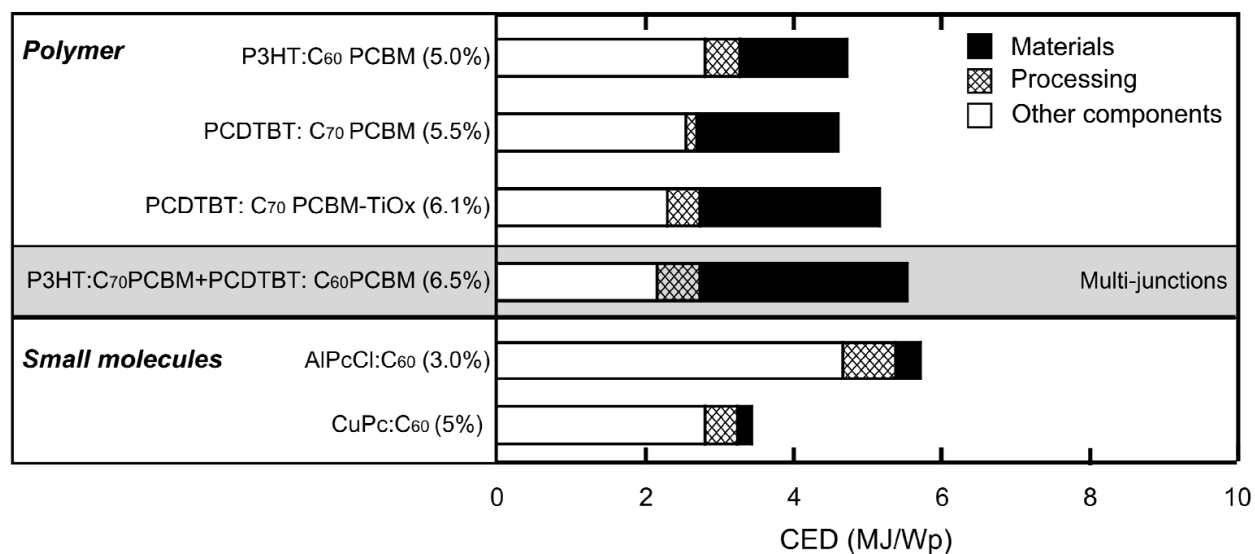

Fig. 12. Cumulative energy demand (CED) for various types of organic photovoltaics, including low bandgap polymer-, small molecule- and multi-junction-polymer devices.

While multi-junction devices increase efficiency, they also increase the devices' complexity and require additional processing steps and materials. In polymer photovoltaics, the major material contributor is the electron acceptor, the importance of which rises with the increasing efficiency of the device due to a higher concentration of larger fullerenes needed to attain the gain in efficiency. There is a small increase in the direct contribution from a block-copolymer compared to the P3HT, but it is actually an improvement considering all other factors. The block copolymer has a lower bandgap with higher absorption coefficient that allows the use of a thinner layer (80-100 nm, compared to 150-200 nm for P3HT) and higher efficiency, so lowering the amount of material required. In addition, the polymer chain can be optimally organized by optimization of the solvent with the copolymer, so eliminating the need for post-processing annealing compared to P3HT, thereby further reducing the contribution from annealing.

In addition, it is apparent that the impact of processing of small-molecule photovoltaics is greater than that of the materials. The relative contribution of the electron acceptor in the small-molecule devices, i.e., unmodified C₆₀, is nearby 30% lower than in polymer photovoltaics, which require the high-energy functionalized fullerenes the fabrication of multi-junction photovoltaics requires additional processing and material to obtain higher efficiency, but presently, they are the predominant option to increase organic photovoltaic

efficiencies above 13%. There are few publications on multi-junction photovoltaics, although efficiencies of 8.3% were reported for double-junction small-molecule photovoltaics (Green, Emery, Hishikawa, and Warta 2011). As illustrated in Fig. 12, the efficiency of multi-junction polymer photovoltaics increases from 6.1% to 6.5%, but the overall impact is an increase in CED, mostly due to the total amount of active material required. The tunnel junction uses materials such as TiO_x and Pedot:PSS that negligibly impact the CED based upon the comparison in Figure 10 with the other materials. The contribution from processing, while markedly similar, actually has a lower impact from annealing and greater impact from solution processing because six layers have to be deposited rather than three. In previous studies, it was assumed that, for future organic photovoltaics, the embodied energy of a photovoltaic with twice the device's efficiency would be half of that of the initial device (García-Valverde, Cherni, and Urbina 2010). This assumption is questionable, as we have shown from this work that increases in the devices' efficiency results from additional processing and new materials that are more energy intensive to produce. Therefore the total embodied energy likely will be higher for the multi-junction- photovoltaics compared to single-junction ones, unless the efficiency is significantly higher to compensate for the extra processing and material requirement. For small molecules, the largest energy contribution is associated with the evaporation process, which requires creating a vacuum. Adding additional layers for a small molecule multi-junction does not significantly raise the CED, so the multi-junction approach might be attractive if the device's efficiency surpasses that of polymer-based devices.

5. Conclusions

This chapter illustrates the use of life cycle assessment for emerging photovoltaics technologies, such as organic photovoltaics. We directly compared small molecule- and polymer-photovoltaics, with new calculations for the emerging specialty materials being used as the donor, acceptor, and interface layers in both single- and multi-junction-designs. An indirect outcome from this work is the creation of life cycle inventory data for new semiconductor materials that feature prominently in organic photovoltaics, but also have tremendous potential in other organic electronic devices (e.g., transistors, light emitting diode). Fullerenes used as acceptors are the most energy-intensive component of organic photovoltaics. While the polymer energy requirement is much lower than that of fullerenes, the embodied energy in low bandgap polymer materials rises with increasing number of steps in their fabrication. Small molecule- and polymer-photovoltaics were found to have a similar CED. For polymer photovoltaics, there is a trend towards using a higher quantity of larger fullerenes, which increases the CED/Wp. Although the differing interface layers are essential for enhanced efficiency, especially for the multi-junction approach, these materials have negligible direct impact, but the deposition and annealing processes are significant.

6. Acknowledgments

The work has been financially supported by the Department of Energy under project DE-FG36-08GO88110 and the Golisano Institute for Sustainability at RIT.

7. References

- Alford, J.M. et al., 2008. Fullerene production in sooting flames from 1,2,3,4-tetrahydronaphthalene. *Carbon*, 46, pp.1623-1625.
- Ameri, T. et al., 2009. Organic tandem solar cells: A review. *Energy & Environmental Science*, 2, pp.347-363.
- Anctil, A. et al., 2011. Material and Energy Intensity of Fullerene Production. *Environmental Science and Technology*, 45(6), pp.2353-2359.
- Capello, C. et al., 2009. A comprehensive environmental assessment of petrochemical solvent production. *International Journal of Life Cycle Assessment*, 14, pp.467-479.
- Cheyns, D., Rand, B.P. & Heremans, P., 2010. Organic tandem solar cells with complementary absorbing layers and a high open-circuit voltage. *Applied Physics Letters*, 97, p.033301.
- EPA, 2006. Life Cycle Assessment: Principles and Practice, Available at: <http://www.epa.gov/nrmrl/lcaccess/pdfs/600r06060.pdf>.
- Espinosa, N. et al., 2011. A life cycle analysis of polymer solar cell modules prepared using roll-to-roll methods under ambient conditions. *Solar Energy Materials & Solar Cells*, 95, pp.1293-1302.
- Frischknecht, R. et al., 2007. Overview and Methodology Final report ecoinvent Data v2.0, Duebendorf, CH.
- Fthenakis, V. et al., 2011. Life Cycle Inventories and Life Cycle Assessments of Photovoltaic Systems, International Energy Agency (IEA) PVPS Task 12, Report T12-02:2011,
- García-Valverde, R., Cherni, J.A. & Urbina, A., 2010. Life cycle analysis of organic photovoltaic technologies. *Progress in Photovoltaics: Research and Applications*, 18(7), pp.535-558.
- Geisler, G., Hofstetter, T.B. & Hungerbühler, K., 2004. Production of Fine and Speciality Chemicals: Procedure for the Estimation of LCIs. *International Journal of Life Cycle Analysis*, 9(2), pp.101-113.
- Green, M.A. et al., 2011. Solar cell efficiency tables (Version 38). *Progress in Photovoltaics: Research and Applications*, 19, pp.565-572.
- Gregg, B.A., 2011. The Photoconversion Mechanism of Excitonic Solar Cells. *MRS Bulletin*, 30(1), pp.20-22.
- Hadipour, A., de Boer, B. & Blom, P.W.M., 2008. Organic tandem and multi-junction solar cells. *Advanced Functional Materials*, 18(2), pp.169-181.
- Hayakawa, A. et al., 2007. High performance polythiophene/fullerene bulk-heterojunction solar cell with a TiO_x hole blocking layer. *Applied Physics Letters*, 90(16), pp.163517/1-163517/3.
- Hischier, R. et al., 2007. Life Cycle Inventories of Electric and Electronic Equipment - Production, Use & Disposal F. report ecoinvent D. v2.0, ed., Duebendorf and St. Gallen.

- Huijbregts, M.A.J. et al., 2006. Is cumulative fossil energy demand a useful indicator for the environmental performance of products? *Environmental Science & Technology*, 40, pp.641-648.
- International Organization for Standardization, 2006. Environmental management-Life cycle assessment-Requirements and guidelines, Switzerland.
- Janssen, R.A.J., Hummelen, J.C. & Sariciftci, N.S., 2005. Polymer-fullerene bulk heterojunction solar cells. *MRS Bulletin*, 30(1), pp.33-36.
- Kim, J.Y. et al., 2007. Efficient tandem polymer solar cells fabricated by all-solution processing. *Science (New York, N.Y.)*, 317(5835), pp.222-5. Available at: <http://www.ncbi.nlm.nih.gov/pubmed/17626879> [Accessed June 10, 2011].
- Kushnir, D. & Sanden, B.A., 2008. Energy Requirements of Carbon Nanoparticle Production. *Journal of Industrial Ecology*, 12(3), pp.360-375.
- Lambourne, R. & Strivens, T.A., 1999. *Paint and Surface Coatings. Theory and Practice*.
- Liang, Y. et al., 2009. Development of New Semiconducting Polymers for High Performance Solar Cells. *Journal of American Chemical Society*, 131, pp.56-57.
- Ma, W. et al., 2005. Thermally stable efficient polymer solar cells with nanoscale control of the interpenetrating network morphology. *Advanced Functional Materials*, 15(10), pp.1617-1622.
- Marković, Z et al., 2007. Comparative Process Analysis of Fullerene Production by the Arc and the Radio-Frequency Discharge Methods. *Journal of Nanoscience and Nanotechnology*, 7, pp.1357-1369.
- Meyer, D.E., Curran, M.A. & Gonzalez, M.A., 2009. An examination of existing data for the industrial manufacture and use of nanocomponents and their role in the life cycle impact of nanoproducts. *Environmental Science & Technology*, 43(5), pp.1256-1263.
- Park, S.H. et al., 2009. Bulk heterojunction solar cells with internal quantum efficiency approaching 100%. *Nature Photonics*, 3(May), pp.297-303.
- PlasticsEurope, 2010. *PlasticsEurope's Eco-profiles*. Available at: <http://www.plasticseurope.org/>.
- Reich-weiser, C., Dornfeld, D. & Horne, S., 2008. Greenhouse Gas Return on Investment: A New Metric for Energy Technology. In 15th International CIRP Conference on Life Cycle Engineering.
- Roes, A.L. et al., 2009. Ex-ante Environmental and Economic Evaluation of Polymer Photovoltaics. *Progress in Photovoltaics: Research and Applications*, 17, pp.372-393.
- Siddiki, M.K. et al., 2010. A review of polymer multijunction solar cells. *Energy & Environmental Science*, 3, pp.867-883.
- Som, C. et al., 2010. The importance of life cycle concepts for the development of safe nanoproducts. *Toxicology*, 269, pp.160-169.
- Szépvolgyi, J. et al., 2006. Effects of Precursors and Plasma Parameters on Fullerene Synthesis in RF Thermal Plasma Reactor. *Plasma Chemistry and Plasma Processing*, 26(6), pp.597-608.

- Takehara, H. et al., 2005. Experimental study of industrial scale fullerene production by combustion synthesis. *Carbon*, 43, pp.311-319.
- Xue, J. et al., 2005. A Hybrid Planar-Mixed Molecular Heterojunction Photovoltaic Cell. *Advanced Materials*, 17(1), pp.66-70.

IntechOpen

IntechOpen

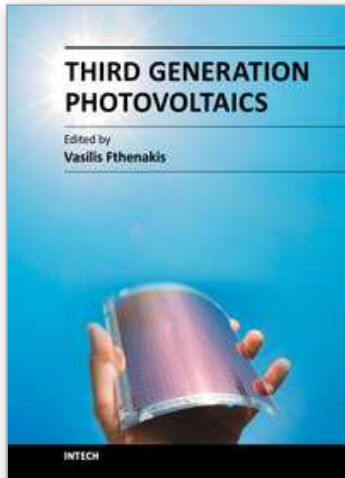

Third Generation Photovoltaics

Edited by Dr. Vasilis Fthenakis

ISBN 978-953-51-0304-2

Hard cover, 232 pages

Publisher InTech

Published online 16, March, 2012

Published in print edition March, 2012

Photovoltaics have started replacing fossil fuels as major energy generation roadmaps, targeting higher efficiencies and/or lower costs are aggressively pursued to bring PV to cost parity with grid electricity. Third generation PV technologies may overcome the fundamental limitations of photon to electron conversion in single-junction devices and, thus, improve both their efficiency and cost. This book presents notable advances in these technologies, namely organic cells and nanostructures, dye-sensitized cells and multijunction III/V cells. The following topics are addressed: Solar spectrum conversion for photovoltaics using nanoparticles; multiscale modeling of heterojunctions in organic PV; technologies and manufacturing of OPV; life cycle assessment of OPV; new materials and architectures for dye-sensitized solar cells; advances of concentrating PV; modeling doped III/V alloys; polymeric films for lowering the cost of PV, and field performance factors. A panel of acclaimed PV professionals contributed these topics, compiling the state of knowledge for advancing this new generation of PV.

How to reference

In order to correctly reference this scholarly work, feel free to copy and paste the following:

Annick Anctil and Vasilis Fthenakis (2012). Life Cycle Assessment of Organic Photovoltaics, Third Generation Photovoltaics, Dr. Vasilis Fthenakis (Ed.), ISBN: 978-953-51-0304-2, InTech, Available from: <http://www.intechopen.com/books/third-generation-photovoltaics/life-cycle-assessment-of-organic-photovoltaics>

INTECH
open science | open minds

InTech Europe

University Campus STeP Ri
Slavka Krautzeka 83/A
51000 Rijeka, Croatia
Phone: +385 (51) 770 447
Fax: +385 (51) 686 166
www.intechopen.com

InTech China

Unit 405, Office Block, Hotel Equatorial Shanghai
No.65, Yan An Road (West), Shanghai, 200040, China
中国上海市延安西路65号上海国际贵都大饭店办公楼405单元
Phone: +86-21-62489820
Fax: +86-21-62489821

© 2012 The Author(s). Licensee IntechOpen. This is an open access article distributed under the terms of the [Creative Commons Attribution 3.0 License](#), which permits unrestricted use, distribution, and reproduction in any medium, provided the original work is properly cited.

IntechOpen

IntechOpen