

We are IntechOpen, the world's leading publisher of Open Access books Built by scientists, for scientists

4,800

Open access books available

122,000

International authors and editors

135M

Downloads

Our authors are among the

154

Countries delivered to

TOP 1%

most cited scientists

12.2%

Contributors from top 500 universities

**WEB OF SCIENCE™**Selection of our books indexed in the Book Citation Index
in Web of Science™ Core Collection (BKCI)

Interested in publishing with us?
Contact book.department@intechopen.com

Numbers displayed above are based on latest data collected.

For more information visit www.intechopen.com

From PET Waste to Novel Polyurethanes

Gity Mir Mohamad Sadeghi and Mahsa Sayaf
*Dep. Polymer Engineering & Color Technology,
Amirkabir University of Technology, Tehran,
I.R. Iran*

1. Introduction

It is well known that Poly (ethylene terephthalate) (PET) is a semi-crystalline thermoplastic polyester widely used in the manufacture of apparel fibers, disposable soft-drink bottles, photographic films, etc. The world production of PET in 2002 was 26 million tons which is expected to rise to 58 million ton in 2012 (Kloss J et al, 2006 & Shukla SR, 2009). The majority of the world's PET production is for synthetic fibers (in excess of 60%) with bottle production accounting for around 30% of global demand. The polyester industry makes up about 18% of world polymer production and is third after polyethylene (PE) and polypropylene (PP). Large numbers of post-consumer PET products, especially bottles and containers, do not create a direct hazard to the environment, but are being concerned due to their substantial volume fraction in the solid waste streams, their high resistance to the atmosphere, their poor biodegradability and photo degradability. Recently, recycling of PET has received a great deal of attention. Although the nontoxic nature, durability and crystal clear transparency of PET during use are major advantages, its non biodegradability is the serious cause of concern to the environmentalists. Since land filling of such non biodegradable waste has severe limitations, chemical recycling is the best possible alternative. Therefore, chemical recycling of PET leads to various advantages: consuming waste to get new useful materials and changing of a non- biodegradable polymer to a biodegradable one. Chemical recycling of PET includes chemolysis of the polyester with an excess of reactants such as water (hydrolysis) (Pusztaszeri SF, 1982, Mishra S et al, 2003; Schwartz J, 1995; Lamparter RA et al, 1985; Tindall GW et al, 1991 & Doerr ML, 1986) alcohols (alcoholysis), glycols (glycolysis) (Akiharu F et al,1986; Ostrowski HS,1975; . Güçlü G et al, 1998, Andrej K, 1998; Berti C et al, 2004; Manfred K et al,1993), amines (aminolysis) (Shukla SR et al,2006 ; Fabrycy E et al,2000;Zahn H et al,1963; Popoola V,1998) and ammonia (ammonolysis) (Blackmon KP et al,1990). Aminolysis has been little explored as chemical degradation of PET for synthesis of useful products. The use of ethanolamine for aminolytic degradation of PET waste has been investigated. (Shukla SR et al, 2006) The product obtained BHETA has potential for further reactions to synthesize useful products such as polyurethanes. There are few reports on the usage of recycled BHETA from PET to synthesis of polyurethanes. Depolymerization of the PET waste, using ethanolamine to obtain BHETA and BHETA-based polyurethanes, has been investigated in our works (Shamsi R et al, 2009; Mohammadi M et al, 2010; Mir Mohamad Sadeghi G et al, 2011). This

chapter aims at the study on synthesis of novel polyurethanes based on PET waste. Firstly, PET and polyurethanes are concisely reviewed, with emphasis on the methods of synthesis, their structures, properties and applications. Then, various chemical decomposition methods of PET are introduced. Using aminolysis in the presence of Ethanolamine, applying of aminolysis product (BHETA) as chain extender or ring opening agent to obtain new polyurethanes are demonstrated. Mechanical, thermal properties, biodegradability, chemical resistance, adhesion of novel synthesized materials are studied. Thirdly, effective parameters such as structural hard segment, chain length, chemical structure, and crystallinity on final properties as well as biodegradability are investigated.

2. Poly (ethylene terephthalate)

Poly (ethylene terephthalate) is a thermoplastic polymer resin of the polyester family and is used in synthetic fibers; beverage, food and other liquid containers; thermoforming applications; and engineering resins often in combination with glass fiber. Depending on its processing and thermal history, polyethylene terephthalate may exist both as an amorphous (transparent) and as a semi-crystalline polymer. The semicrystalline material might appear transparent (particle size < 500 nm) or opaque and white (particle size up to a few microns) depending on its crystal structure and particle size. Its monomer, BHET can be synthesized by the esterification reaction between terephthalic acid and ethylene glycol with water as a byproduct, or by transesterification reaction between ethylene glycol and dimethyl terephthalate with methanol as a byproduct (Fig. 1-a). Polymerization is through a polycondensation reaction of the monomers (done immediately after esterification/transesterification) with water as the byproduct (Fig.1-b).

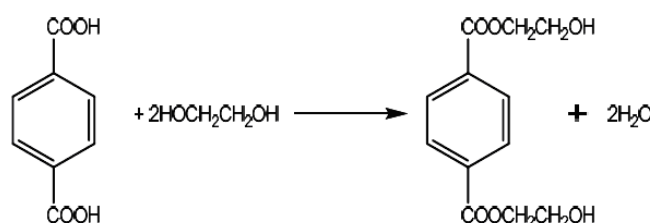

Fig. 1. a. Chemical Reaction between ethylene glycol and terephthalic acid yields BHET.

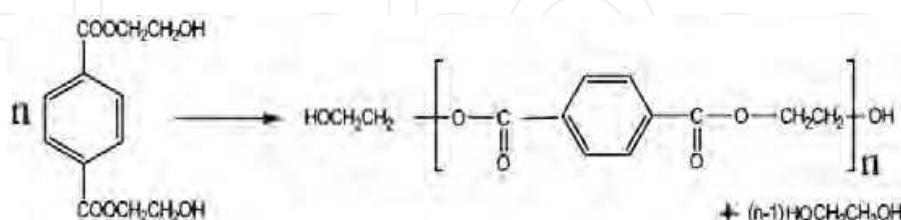

Fig. 1. b. Polycondensation of BHET yields PET.

3. PET waste, as an opportunity instead of a problem

PET is used in the preparation of a variety of products differing widely in their physical characteristics and hence, their end uses. The varieties of prominence are fibers and filaments, sheets and disposable soft-drink, soda drinks, juice, mineral water, soy sauce bottles, photographic films, etc. The world production of PET in 2002 was 26 million tons

which is expected to rise to 55 million ton in 2010. PET resin, or bottle grade, is one of the fastest growing plastics markets. Polyester fiber is the second largest segment, but the market is mature. The third use, film, is also a mature market, for example PET market in USA in 2008 could be shown in Fig.2.

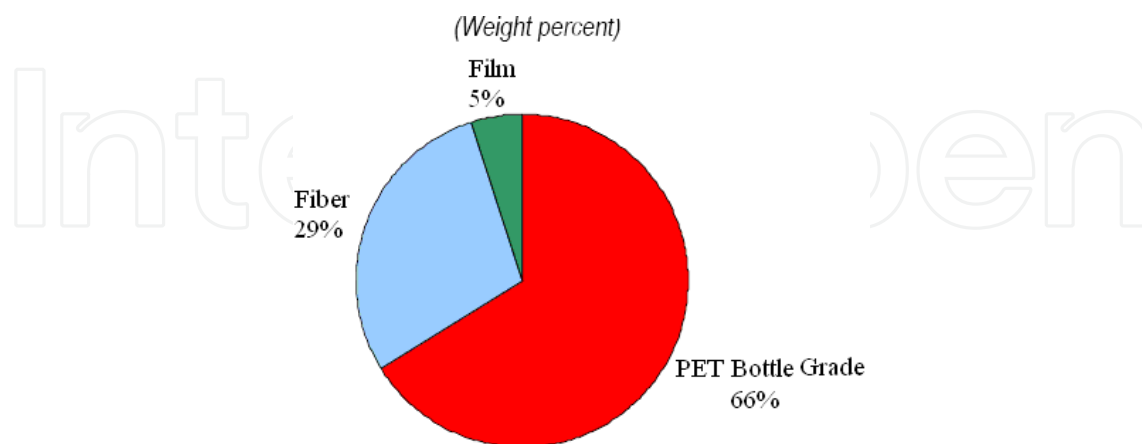

Fig. 2. PET market in USA in 2008(chemsystem.com,nexant ,PERP 07/08-5:1-8).

Large numbers of Post-consumer PET products especially bottles and containers do not create a direct hazard to the environment, but as a problem due to its substantial volume fraction in the solid waste streams, its high resistance to the atmosphere, its poor biodegradability and photo degradability. PET accounts for more than 8% by weight and 12% by volume of the world's solid waste (Shamsi R et al, 2009).

An estimated billion plastic bottles are disposed of each year, while recycling a single plastic bottle can conserve enough energy to light a 60 W light bulb for up to 6 h.

Recently, recycling of PET has received a great deal of attention and many attempts are currently directed toward recycling of post-consumer PET products because of both environmental protection and economic benefits. Also necessity for recycling of this product is felt more (Fig 3). In Singapore, 684,400 tones of plastic waste were generated in 2008 and the recycling rate was 9%. Although the nontoxic nature, durability and crystal clear transparency of PET during use are major advantages, its non biodegradability is the serious cause of concern to the environmentalists. Because it isn't appropriate to dispose of waste PET by land-filling, alternative methods of recycling of waste PET products include physical and chemical recycling have been developed.

To minimize the fast buildup of PET waste, different mechanical, thermal, and chemical methods to separate, recover and recycle PET from post-consumer waste stream have been used (Mohammadi M et al, 2010). Products made from recycled PET bottles include carpeting, concrete, insulation and automobile parts. Recycled PET bottles are also used in drainage filtration systems, asphalt concrete-mixes and road stabilizations. Recycling rate of such polymer products is however still low comparing to that of paper, glass and metals. Currently only 3.5% of generated polymeric products is recycled whereas these percentages for paper, glass and metals are, respectively, 34%, 22% and 30%.

Physical recycling of PET consists of the collection, separation, digestion, granulation of polymer waste and then recirculation into production. Blending of materials with PET waste

has also been studied. The effect of waste PET addition on thermal transmission (or insulation) property of ordinary concrete has been studied and reported that corresponding percentages for PET bottle pieces vary between 10.27% and 18.16%, depending on the geometries of added pieces. Moreover, concrete-PET blends due to their ability in water absorption, a possible application could be in sports courts and pavements which need good water drainage. M.C. Almaza'n and co worker proposed a different method to obtain activated carbon using the actual waste plastic commercial vessels made of PET as raw material (Mohammadi M et al, 2010).



Fig. 3. PET waste as a threat, serious cause of concern to the environmentalists.

In a recyclability analysis determination of a global index which takes into account social, economic and environmental aspects is believed to be an interesting approach for industrial organizations. Thus, in this case following aspects may be analyzed:

- Social: A stronger and wide-spread PET recycling sector (market) would generate employment and contribute to reduce the volume of municipal solid wastes.
- Environmental: PET recycling contributes to reduce mass and energy consumption.
- Economic: Technical/economic analyses could demonstrate the viability of the chemical recycling of PET regarding costs, with adequate technical applications. Since land filling of such non biodegradable waste has severe limitations, chemical recycling is the best possible alternative. Therefore, chemical recycling of PET leads to various advantages: consuming waste to get new useful materials and changing of a non- biodegradable polymer to a biodegradable one.

3.1 Chemical recycling of PET waste

Chemical recycling of PET includes chemolysis of the polyester with an excess of reactants such as water (hydrolysis), alcohols (alcoholysis), glycols (glycolysis), amines (aminolysis) and ammonia (ammonolysis). (Shamsi R et al, 2009; Mohammadi et al, 2010 & Mir M. Sadeghi G et al, 2011).

3.1.1 Hydrolysis

PET is polyester, and the functional ester group can be hydrolyzed by water. Hydrolysis of PET can be carried out in an acid, alkaline or neutral environment to produce monomers

terephthalic acid (TPA) and ethylene glycol. During hydrolysis reaction, PET hydrolyzes to a carboxylic acid and an alcohol as follows:

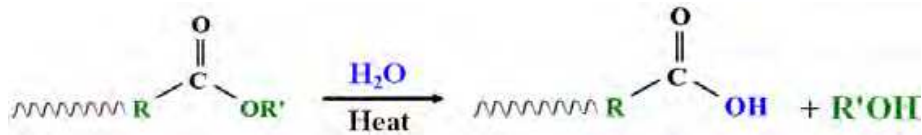

Fig. 4. Hydrolysis Reaction.

Life time alternative in a PET chemical recycling plant is depicted in Fig 5. Kinetics of hydrolysis of PET Pellets in Nitric Acid (Mohammadi M et al, 2010), kinetics and Thermodynamics of Hydrolytic acidic and neutral depolymerization of poly (ethylene terephthalate) at high pressure and temperature has been investigated.

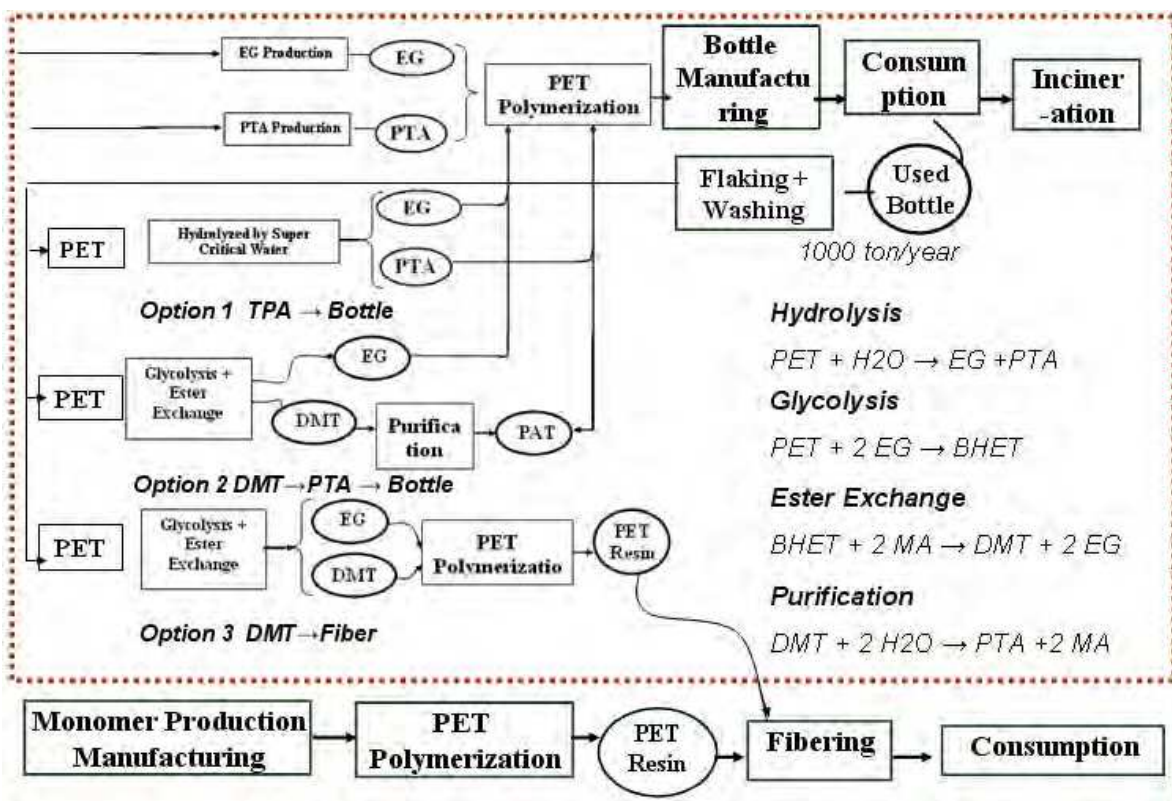

Fig. 5. Life time alternative for PET chemical recycling, DMT (Dimethyl terephthalate), TPA (Pure terephthalic acid) commonly uses PTA, EG (Ethylene Glycol).

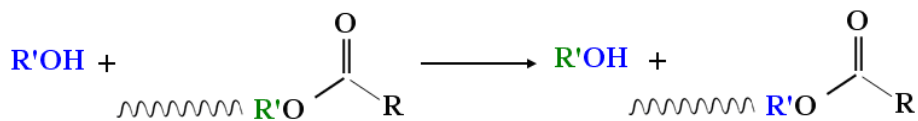

Fig. 6. Glycolysis Reaction.

3.1.2 Glycolysis

Glycolysis is breakdown of ester linkages by a glycol, resulting in oligomers or oligoester diols/polyols with hydroxyl terminal groups. Oligoesters coming from the glycolysis of PET

waste have been well known to be utilized as a starting material in the manufacture of unsaturated polyesters, vinyl ester resins, epoxy resins, alkyd resins and polyurethanes. Glycolysis is carried out using different glycols like; ethylene glycol, propylene glycol, 1, 4-butanediol and triethylene glycol, diethylene glycol (DEG), dipropylene glycol (DPG), glycerol (Gly) and etc. During glycolysis reaction, the organic group R'' of an ester with the organic group R' of an alcohol exchanges. (Shamsi R et al, 2009; Mohamadi et al, 2010 & M. M. Sadeghi G et al, 2011)

3.1.3 Methanolysis

Methanolysis is the degradation of PET using methanol at high temperatures and high pressures with the main products being dimethyl terephthalate (DMT) and ethylene glycol.

Methanolysis is the recycling process which has been practiced and tested on a large scale for many years in the past. In this case, polyester waste is transformed with methanol into DMT (Dimethyl terephthalate), under pressure and in presence of catalysts. Finally the crude DMT is purified by vacuum distillation. Degradation of PET using ethylene glycol at high temperatures and high pressures with the main products being BHET is used to produce some different materials such as polyester, polyurethane resins and esteric plasticizer, as shown in Fig. 7.

3.1.4 Aminolysis

Aminolysis is another method of chemical degradation of PET, which has been relatively little investigated, compared to the other techniques.

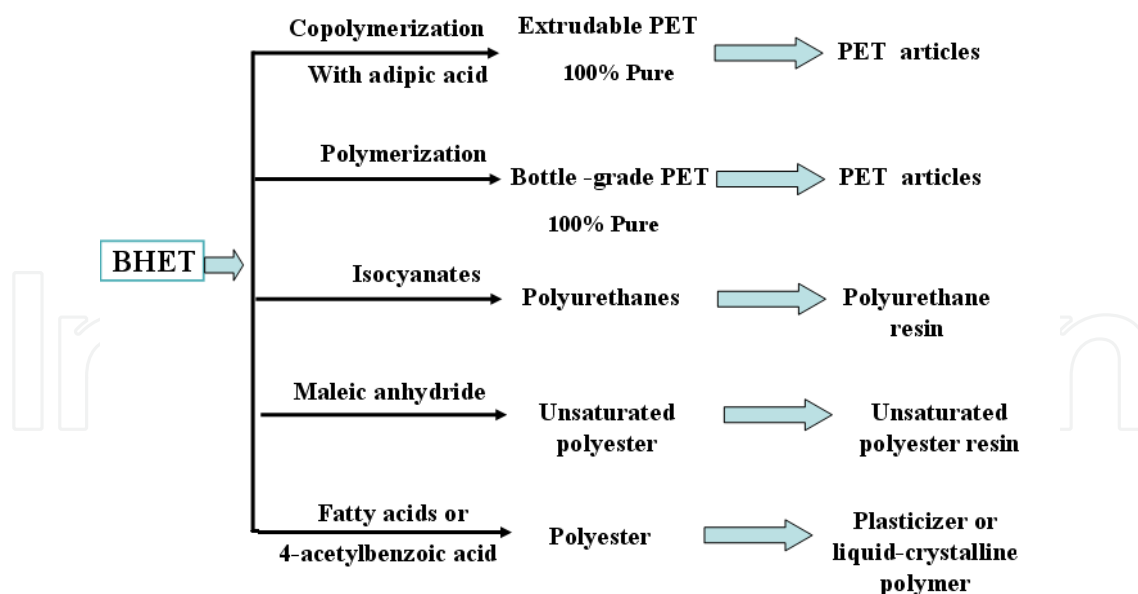

Fig. 7. Using of BHET (glycolysis product of PET waste) to obtain other materials.

Depolymerization of PET waste has been carried out using various amines, such as ethanolamine, benzylamine, hexamethylenediamine, aniline, methylamine hydrazine monohydrate and some polyamines. Catalysts such as lead acetate, glacial acetic acid, sodium acetate and potassium sulfate are usually used to facilitate the reaction. Aminolysis

products, such as BHETA, have the potential to undergo further reactions to yield secondary value-added products. In this direction, very recently the synthesis of unsaturated polyesters polyurethanes, epoxy resin hardeners and non-ionic polymeric surfactants has been reported.

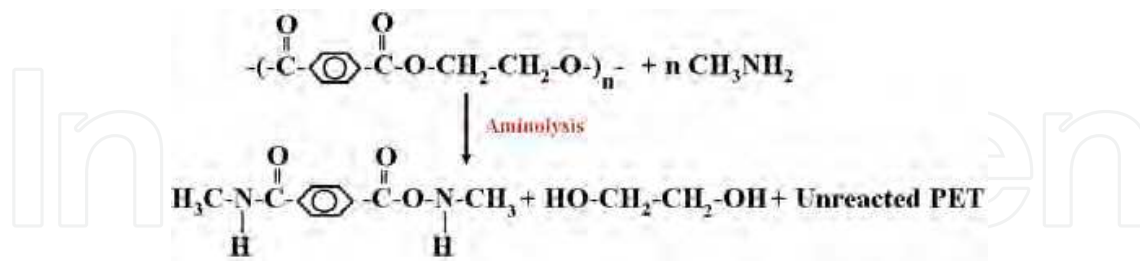
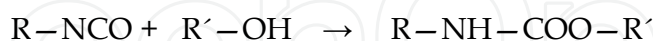

Fig. 8. Aminolysis reaction.

Zahn and Pfeifer carried out aminolysis of PET with solutions of hydrazine, benzyl amine, ethylene diamine, hexamethylene diamine, piperidine and aniline. They obtained different reaction products as the diamides of terephthalic acid, which do not possess any potential for further chemical reactions. According to Popoola the basicity of an amine relative to water as well as its steric hindrance due to size determines the rate of degradation of PET. During aminolysis of PET with methylamine, the methyl terephthalamide is obtained, which isn't enough reactive for its recycling into any useful product through further reactions. Shukla and Harad have been investigated the use of ethanolamine for the aminolytic degradation of PET waste in the presence of different simple chemicals such as glacial acetic acid, sodium acetate and potassium sulphate as catalysts. The product obtained, BHETA has potential for further reactions to obtain useful products.

4. Polyurethane

Polyurethane is any polymer composed of a chain of organic units joined by carbamate (urethane) links. Polyurethane polymers are formed through step-growth polymerization, by reacting a reactant (with at least two isocyanate functional groups) with another reactant (with at least two hydroxyl or alcohol groups) in the presence of a catalyst. Generalized formation reaction of the urethane group is:



Thermoplastic polyurethanes (TPUs) are linear polymers formed by the polymerization reaction of three basic components:

1. A diisocyanate (NCO-R-NCO)
2. A short-chain diol, so-called chain extender (OH-R'-OH)
3. A long-chain diol (OH OH)

As shown in the above reaction urethane linkage is produced by reacting an isocyanate group, $-N=C=O$ with a hydroxyl (alcohol) group, $-OH$. In fact, polyurethanes are produced by the polyaddition reaction of a polyisocyanate with a polyalcohol (polyol) in the presence of a catalyst and other additives. The reaction product is a polymer containing the urethane linkage, $-RNHCOOR'$. A broad range of physical properties can be achieved by varying the chemistry and molecular weight of the various components, and through

manipulation of the ratios in which they are reacted in polyurethanes. Therefore polyurethanes have received recent attention as regards the development of wide family of polymeric materials (paints, adhesives, elastomers, flexible, and rigid foams, etc.) and thus play an important and increasing role in our daily life. The greatest advantage offered by polyurethane is their versatility, both in finished product properties and ease of production and application. By the proper choice of isocyanate and polyol, products can be made with properties ranging from low viscosity resins used in printing to high modulus solids used in industrial parts. Polyurethanes are applied to the manufacture of flexible, high-resilience foam seating; rigid foam insulation panels; microcellular foam seals and gaskets; durable elastomeric wheels and tires; automotive suspension bushings; electrical potting compounds; high performance adhesives; surface coatings and surface sealants; synthetic fibers (e.g. Spandex); carpet underlay; and hard-plastic parts (i.e. for electronic instruments) and any other industrial parts.

4.1 Components

Polyols are higher molecular weight materials manufactured from an initiator and monomeric building blocks. They are most easily classified as polyether polyols, which are made by the reaction of epoxides (oxiranes) with active hydrogen containing starter compounds, or polyester polyols, which are made by the polycondensation of multifunctional carboxylic acids and hydroxyl compounds.

Isocyanates two or more functional groups are required for the formation of polyurethane polymers. Volume wise, aromatic isocyanates account for the vast majority of global diisocyanate production. Aliphatic and cycloaliphatic isocyanates are also important building blocks for polyurethane materials, but in much smaller volumes. The two most important commercial, aromatic isocyanates are toluene diisocyanate (TDI) and diphenylmethane diisocyanate (MDI). TDI consists of a mixture of the 2,4- and 2,6-diisocyanatotoluene isomers. The most important product is TDI-80 (TD-80), consisting of 80% of the 2,4-isomer and 20% of the 2,6-isomer. This blend is used extensively in the manufacture of polyurethane flexible slabstock and molded foam. TDI, and especially crude TDI and TDI/MDI blends can be used in rigid foam applications, but have been supplanted by polymeric MDI. TDI-polyether and TDI-polyester prepolymers are used in high performance coating and elastomeric applications.

Chain extenders (f =2) and cross linkers (f =3 or greater) are low molecular weight hydroxyl and amine terminated compounds that play an important role in the polymer morphology of polyurethanes. The choice of chain extender also determines flexural, heat, and chemical resistance properties. The most important chain extenders are ethylene glycol, 1,4-butanediol(1,4-BDO or BDO),1,6-hexanediol,cyclohexane,dimethanol and hydroquinone bis (2-hydroxyethyl) ether (HQEE).

4.2 Microstructure of polyurethanes

Segmented polyurethanes that consist of alternating soft and hard segments offer unique possibilities of tailor-made polymers by varying block length and composition. The structure of the lineal polymeric chain of thermoplastic polyurethane is in blocks, alternating two different types of segments linked together by covalent links, forming a block copolymer. These segments are:

4.2.1. Hard Segments which are segments formed by the reaction of the diisocyanate and the short-chain diol. They have a high density of urethane groups of high polarity, and for this reason, they are rigid at room temperature (high hardness).

4.2.2. Soft Segments which are segments formed by the reaction of the diisocyanate and the long-chain diol. They have a low polarity as they have a very low density of urethane groups, and therefore, they are flexible at room temperature (very low hardness). A general structure of thermoplastic polyurethane's chain would be as Fig. 9:

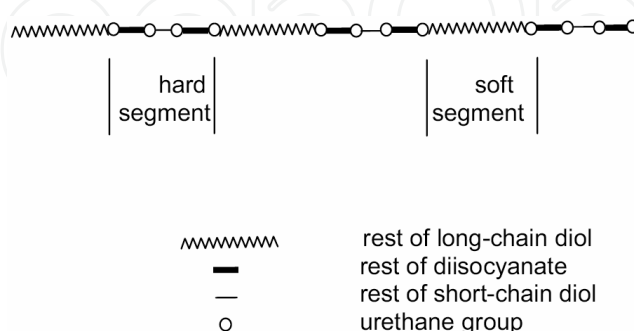

Fig. 9. General structure of polyurethane's chain.

The polarity of hard segments produces a strong attraction between them, which causes a high degree of aggregation and order in this phase, forming crystalline or pseudo-crystalline areas located in a soft and flexible matrix. This so-called phase separation between both blocks will be more or less important, depending on the polarity and molecular weight of the flexible chain, the production conditions, etc. The crystalline or pseudo-crystalline areas act as a physical crosslink, which accounts for the high elasticity level of TPUs, whereas the flexible chains will impart the elongation characteristics to the polymer. The schematic representation of the segmented micro structure and two-phase morphology of polyurethane are shown in Figs. 10 and 11. These "pseudo crosslinks", based on hydrogen bonding between carbonyl groups and $-NH$ groups of various chains, however, disappear under the effect of heat, and thus the classical extrusion, injection molding and calendaring processing methods are applicable to these materials.

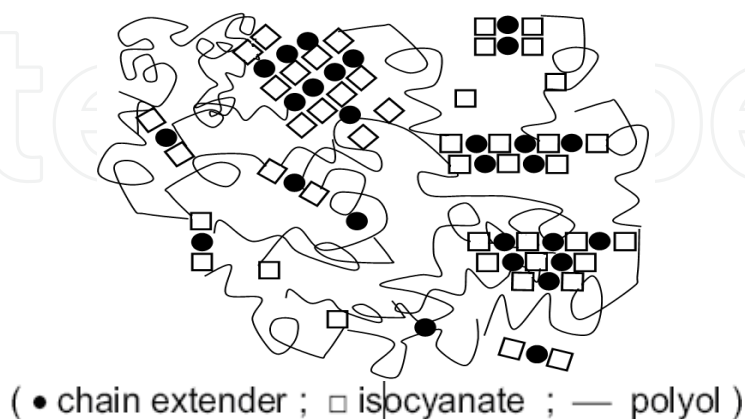

Fig. 10. Schematic represent of microstructure of segmented polyurethane chains.

Consequently –and not less importantly– TPU scraps can be reprocessed. When TPUs are cold, the "pseudocrosslinks" reappear again, providing the elastic properties to the obtained

article. When TPUs are dissolved in a proper solvent, the “pseudo crosslinks” are also broken up by the solvent, and therefore, disappear. Due to this it is possible to apply a TPU in solution by classical methods of coating applications; when the solvent evaporates the “pseudo crosslinks” are formed again.

The soft domains provide the thermoplastic polyurethane with a very low T_g , in comparison with other polymers of the same hardness, maintaining the elasticity at very low temperatures. The presence of polar and non polar counter balanced microdomains is the cause of the good chemical resistance of TPUs, particularly oil and grease resistance. Thermoplastic polyurethanes are very versatile items, since a variety of soft and hard segments can be combined, with their respective ranges of molecular weights, and considering also the variety of molecular weights of the final polymer.

So that it is possible to obtain from very soft (60 Shore A) to very hard polyurethanes (80 Shore D), with different degrees of crystallinity, to be used in many applications and market segments which require high performance. This peculiar structure which differentiates thermoplastic polyurethanes from other polymers provides polyurethanes with the following main properties:

- Very high elasticity
- Excellent abrasion resistance
- Very good tear strength
- Good oil and grease resistance
- Excellent mechanical properties, combined with a rubber-like elasticity
- Outstanding low-temperature performance
- High transparency

4.3 Morphology

Chain extenders play an important role in the polymer morphology of polyurethane fibers, elastomers, adhesives, and certain integral skin and microcellular foams. The elastomeric properties of these materials are derived from the phase separation of the hard and soft copolymer segments of the polymer, such that the urethane hard segment domains serve as cross-links between the amorphous polyether (or polyester) soft segment domains.

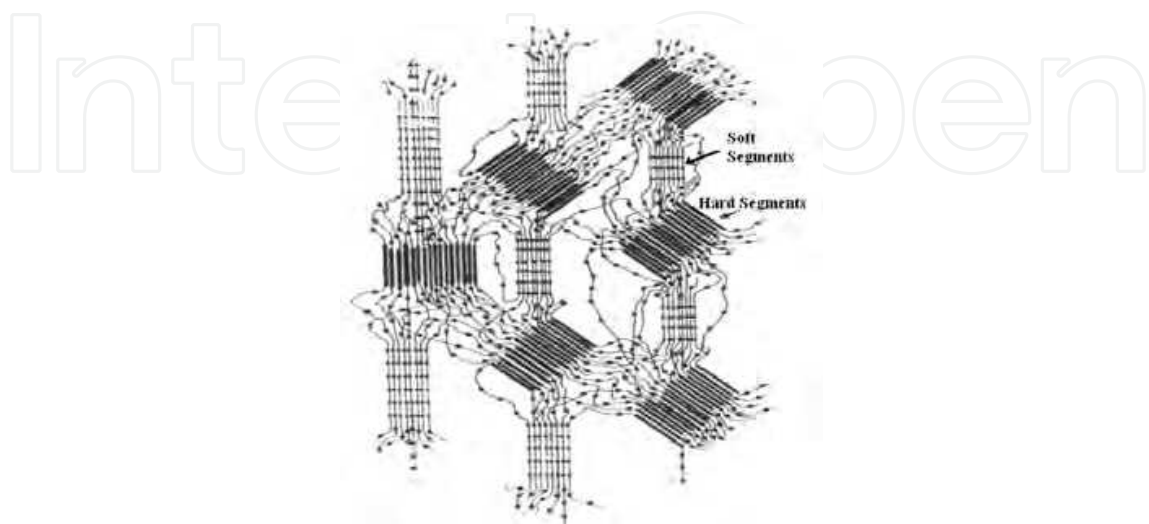

Fig. 11. Schematic representation of two-phase morphology in polyurethanes.

Schematic representation of the superstructure (domain and chain formation) and dimensions in polyurethanes is shown in Fig.12. This phase separation occurs because the mainly non-polar, low melting soft segments are incompatible with the polar, high melting hard segments. The soft segments, which are formed from high molecular weight polyols, are mobile and are normally present in coiled formation, while the hard segments, which are formed from the isocyanate and chain extenders, are stiff and immobile. Because the hard segments are covalently coupled to the soft segments, they inhibit plastic flow of the polymer chains, thus creating elastomeric resiliency.

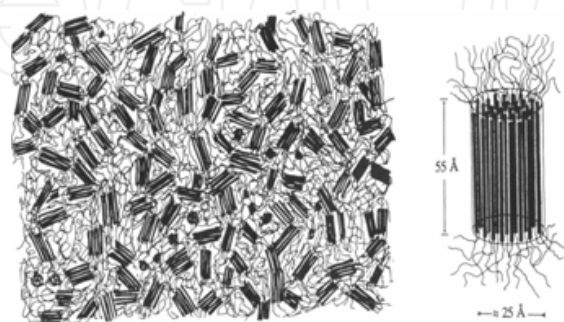

Fig. 12. Schematic representation of superstructure (domain and chain formation) in polyurethanes.

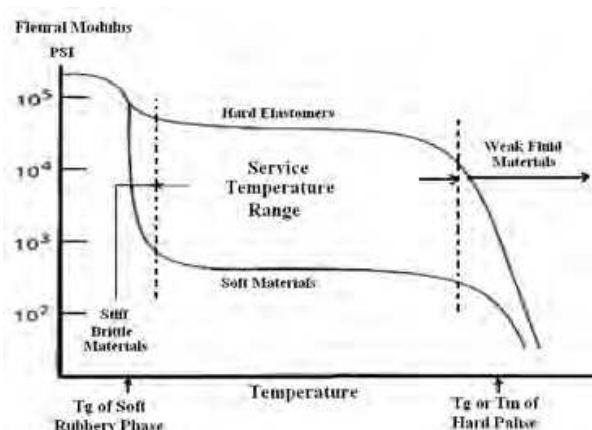

Fig. 13. Schematic representation of soft and hard segments thermal transitions.

Upon mechanical deformation, a portion of the soft segments are stressed by uncoiling, and the hard segments become aligned in the stress direction. This reorientation of the hard segments and consequent powerful hydrogen bonding contributes to high tensile strength, elongation, and tear resistance values. Phase separation in polyurethanes can be studied by dynamic thermal analysis. Thermal transitions of hard and soft segments of a typical polyurethane consisted of a soft rubbery phase and hard phase are presented in Fig. 13. According to nature and physical chemistry properties of polyurethanes, increasing of hard segment content affects on mechanical as well as their thermal properties definitely.

4.4 Wide variety of soft & hard segments in synthesis of polyurethanes

A broad range of physical properties can be achieved by varying the chemical structure and molecular weight of the various components and also through manipulation of the ratios in

which they are reacted in polyurethanes. Therefore, polyurethanes have received recent attention with regard to the development of degradable polymers because of their great potential in tailoring polymer structures to achieve mechanical properties and biodegradability to suit variety of applications such as biodegradable polymers, soft tissue adhesives, clinical demand and meniscus scaffold. Multiblock copolymers based on caprolactone and lactic acid, polyglycoles, polyesters and multifunctional aliphatic carboxylic acids as soft segments have been investigated used in various applications such as medical or industrial fields. Commercial polycaprolactones with different molecular weights as a soft segment, Polycaprolactone-based polyurethanes using diols such as Ethyleneglycole BHET, 1,4-butanediol or other diols as chain extender for ring opening polymerization of caprolactone have been studied. Using of nature-based polyols to prepare polyurethane foams is common but there are few reports on elastomeric polyurethane. Presence of aromatic ring in PET structure caused to improve mechanical and thermal properties of polyurethane structure; while presence of esteric bonds leads to biodegradation. (Yeganeh et al, 2007; Heijka R et al, 2005)

5. Novel polyurethanes based on aminolysis product of PET waste

The product obtained, BHETA has potential for further reactions to synthesize useful products. Using ethanolamine to obtain BHETA and BHETA-based polyurethanes has been investigated in author's works. Three types of polyurethanes have been synthesized using BHETA. In the first case, BHETA is used as ring opening agent in caprolactone polymerization, and then novel biodegradable polyurethane has been synthesized. In the second and third cases, BHETA is used as chain extender to synthesis of high modulus and special polyurethanes which is discussed in the next topics.

5.1 First step: Aminolysis of PET waste to obtain BHETA

In aminolysis with ethanolamine, the obtained product, BHETA is in its pure. Mechanism of synthesis of BHETA which proposed by Shukla and Harad is shown in Fig. 14. (Shukla SR, et al (2006). Ethanolamine was used for the aminolysis of PET waste materials in the molar ratio 1:6 (PET: ethanolamine) under reflux in the presence of catalyst for time period up to 5 h. The catalyst, sodium acetate, was used in concentration 1% by weight of polymer. At the end of the reaction, distilled water was added in excess to the reaction mixture with vigorous agitation to precipitate out the product, BHETA.

The filtrate contained mainly unreacted ethanolamine and little quantities of a few water soluble PET degradation products. The precipitate obtained was filtered and dissolved in distilled water by boiling for about 20 min. White crystalline powder of BHETA was obtained by first concentrating the filtrate by boiling and then chilling it. It was further purified by recrystallisation in water. It was then dried in an oven at 80°C. Different techniques of analysis were used for characterization of BHETA.

After synthesis and high purification, BHETA has been characterized using ¹H NMR and Fourier transform infrared (FTIR) spectroscopy depicted in Figures 15-16. BHETA has been shown in Fig. 15, it may be clearly seen that the spectrograph contains peaks at 1056 and 3288 Cm^{-1} indicating the presence of primary alcohol. The peaks for secondary amide stretching are observed at 1311, 1554 and 3369 Cm^{-1} . Fig. 16 shows the ¹H NMR spectra of

chain extender. The purified BHETA was characterized by FTIR, ^1H NMR, and melting point. Synthesized BHETA has been melted at 227°C .

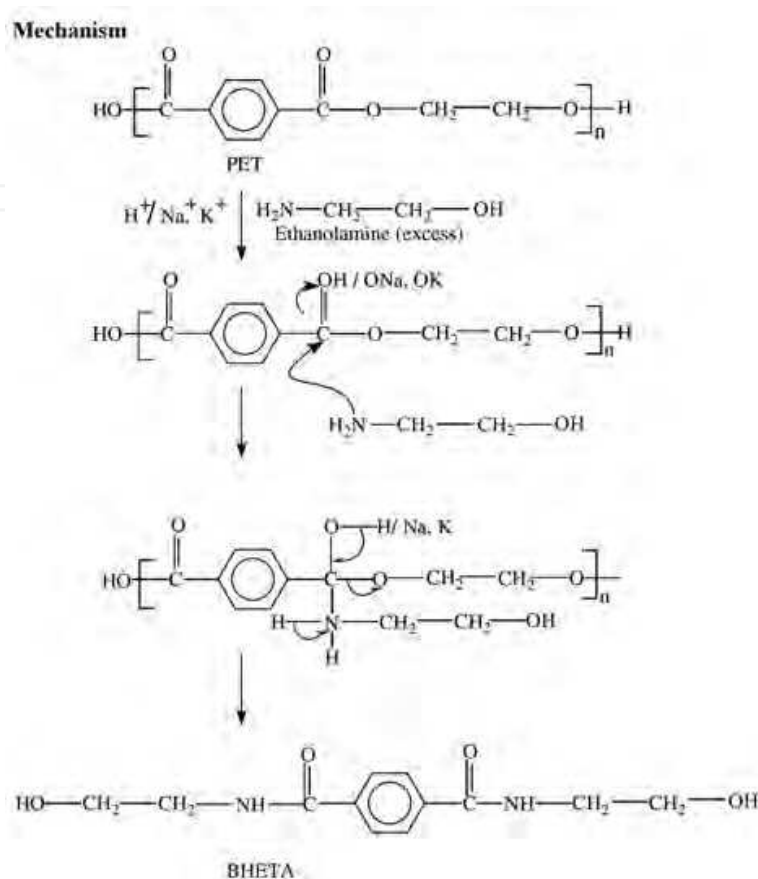

Fig. 14. Depolymerization mechanism of (2-hydroxy ethylene) Terephthalamide.

The FTIR spectrograph of the purified As can be seen, the shift and splitting pattern of ^1H NMR at 8.52 ppm, 7.91 ppm, 4.73 ppm, 3.52 ppm and 3.34 ppm, corresponding to H of the amine group, aromatic ring, hydroxyl Group, CH_2 bonded to hydroxyl group, and CH_2 bonded to amine group respectively. These obtained results confirmed that the PET fibers depolymerized and expected product (BHETA) was synthesized successfully.

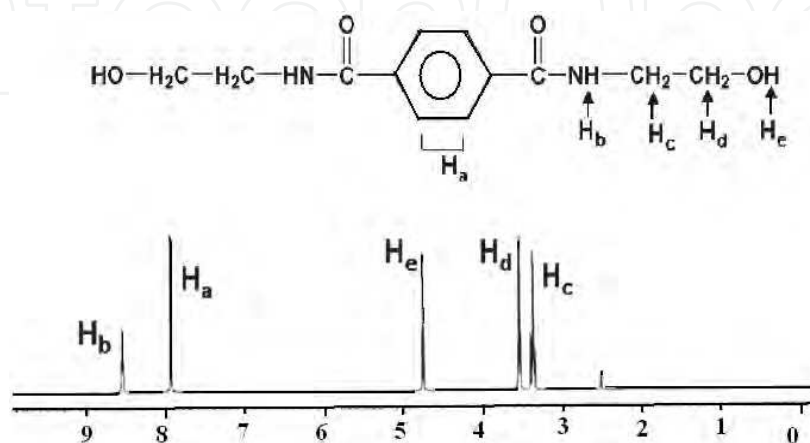

Fig. 15. ^1H NMR spectrum of BHETA.

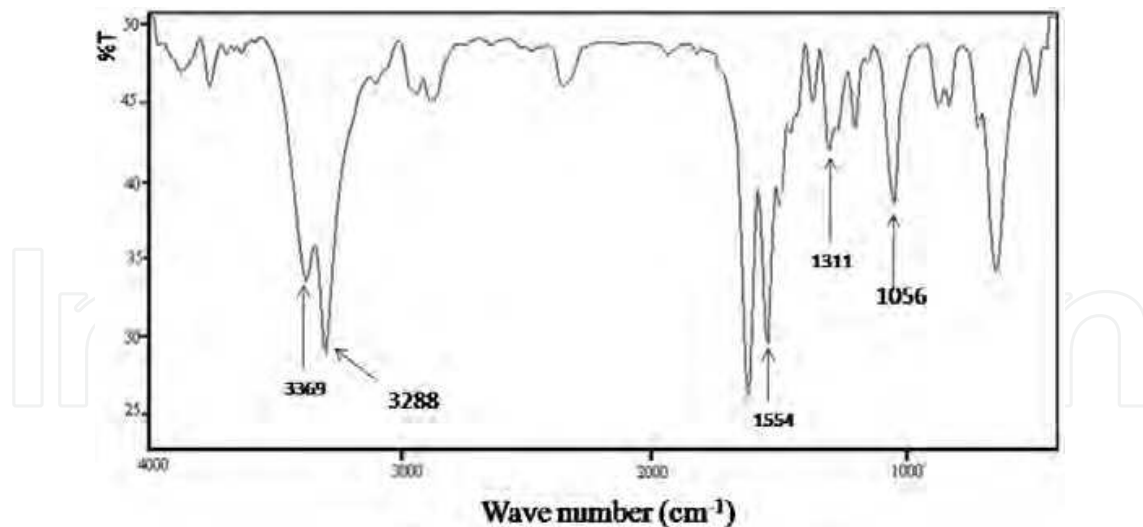

Fig. 16. FTIR spectrum of BHETA.

5.2 Synthesis of polyurethanes based on BHETA

Three types of polyurethanes have been synthesized based on BHETA. In the first case, BHETA is used as ring opening agent in caprolactone polymerization, and then novel biodegradable polyurethane has been synthesized. In the second and third cases, BHETA is used as chain extender to synthesis of special and high modulus polyurethanes as follows:

6. Biodegradable polyurethanes based on ϵ -Caprolactone

Polyols with different molecular weights have been synthesized through ring opening polymerization of caprolactone by BHETA. Polyurethanes with different soft segment chain-lengths have been synthesized using above-mentioned polyols.

6.1 Ring opening polymerization: Using of BHETA

Ring opening polymerization of caprolactone by BHETA is a unique method which is used to synthesis of biodegradable polyurethanes. BHETA synthesized locally was reacted with ϵ -caprolactone through ring opening polymerization at 130°C using 1 wt% DBTDL as the catalyst for 3.5 h in a round-bottom flask equipped with a condenser, stirrer, thermometer and nitrogen gas-inlet tube. The reaction and HNMR spectrum of the synthesized polyol is shown in Fig. 17. Polyols with different molecular weights through ring opening polymerization of caprolactone by BHETA have been synthesized. (Mir M. Sadeghi et al, 2011).

The various molar ratios of ϵ -Caprolactone to BHETA used in the synthesis of polyols, named Polyol-8 to Polyol-142, are shown in Table 1. Then urethane linkages were formed using Di-isocyanate without chain extender. For synthesis of polyurethanes (PU-8 to PU-142) at first, polyols were extended with HDI. Calculated amount of HDI/DMF solution was added drop-wise at 110°C. The homogeneous mixture was then poured slowly into a Teflon mold and maintained at 60°C for 12 h. The films were then removed and placed in a desiccator for testing.

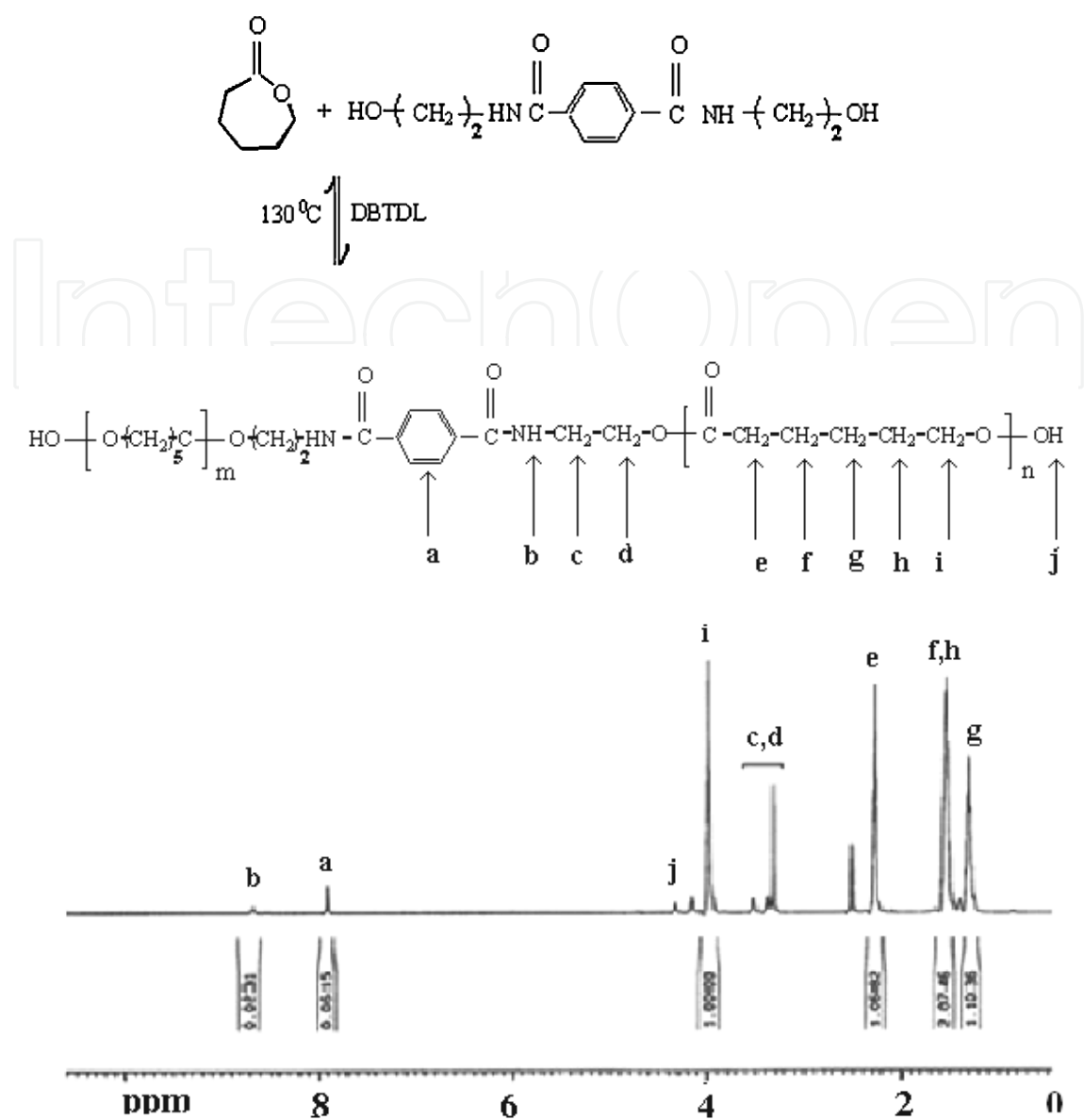

Fig. 17. Ring opening polymerization of caprolactone by BHETA to obtain polyol.

Sample	Molar ratio of ϵ -caprolactone to BHETA	n (theory)	M_n (theory)	n (experimental) ^a	M_n (experimental) ^a
Polyol-8	8	4	1196	3.97	1189
Polyol-22	22	11	2792	10.3	2632
Polyol-38	38	19	4616	17	4160
Polyol-76	76	38	8948	37	8720
Polyol-142	142	71	16472	71	16472

^a Obtained from HNMR spectrum

Table 1. Molar ratios, theoretical and experimental " M_n " and "n" of used polyols.

6.2 Polyurethane characterization

6.2.1 FTIR spectroscopy

FTIR spectra of polyurethanes with different polyol chain lengths are shown in Fig. 18. There are distinctive absorbance bands at *ca* 3435 Cm^{-1} (nonbonded -NH groups), *ca* 3330 Cm^{-1} (bonded -NH groups), *ca* 2940 and *ca* 2865 Cm^{-1} (asymmetric and symmetric CH_2 groups), *ca* 1730 Cm^{-1} (overlapped carbonyl groups of polycaprolactone and urethane linkages), *ca* 1620 Cm^{-1} (C=C stretching vibration in aromatic ring), *ca* 1540 Cm^{-1} (-CO-N amide II), *ca* (1468,1418,1390,1368) Cm^{-1} : various modes of CH_2 vibrations, *ca* (1240,1169,1040) Cm^{-1} : stretching vibration of the ester groups and stretching of the ether group ($\sim 1100 \text{Cm}^{-1}$).

Mechanical properties of polyurethanes and Mn of used polyol are shown in Table 2.

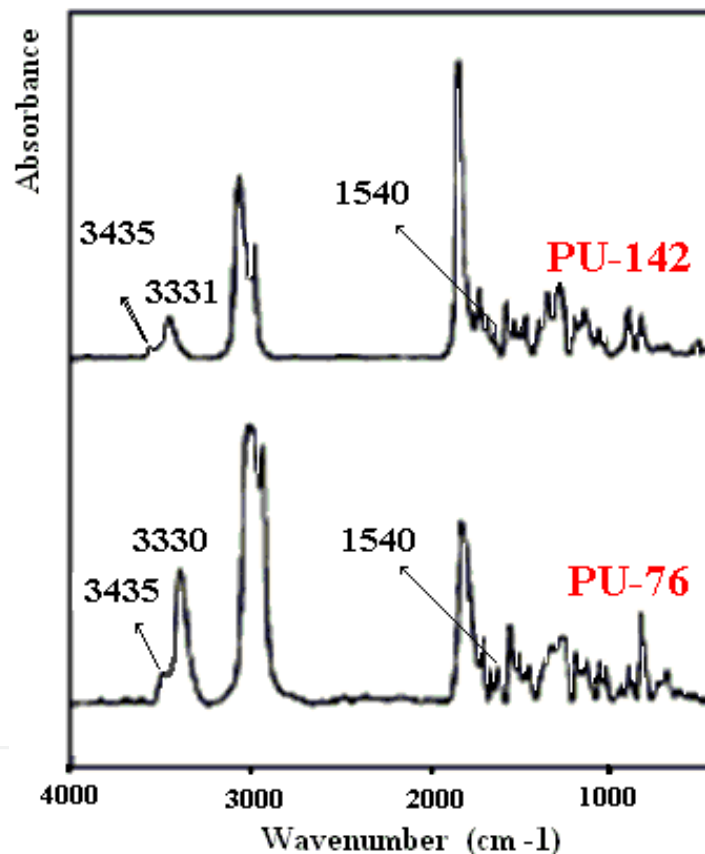

Fig. 18. FTIR spectra of PU-22 to PU-142.

Sample	Mn	T _g °C	T _m °C	ΔH _f J/g	α _C * %	Tensile strength (MPa)	Elongation @ break %
PU-22	2,632	-46.1	36	-26.55	18	16	440
PU-38	4,160	-48.4	55.3	-41.4	29	14	520
PU-76	8,720	-50.5	60.8	-64.4	45	10	6
PU-142	16,472	-56	63.6	-74.35	52	16	7

Table 2. Thermal and mechanical properties of polyurethanes and Mn of used polyol.

6.2.2 DSC results

DSC thermograms and the related data such as T_g , T_m , ΔH_f and degree of crystallinity (α_c) are shown in Fig. 20 and Table 2. The melting curves in Fig. 21 clearly show an endotherm for the melting, indicating the presence of one distinct crystalline zone in all polymers, which could be ascribed to ordering or size in the crystallites. As shown obviously in Table 2, increasing of molecular weight of synthesized polycaprolactone leads to a regular increase in the observed melting point from 36°C to 63 °C and also in heat of fusion of samples.

As shown in Table 2, the crystallinity, α_c , of polycaprolactone (PCL) phase increases with increasing molar ratio of polycaprolactone to BHETA. α_c is calculated using a value of ΔH_f for completely crystalline PCL, equal to 142 J g⁻¹. T_m of PU containing PCL with lower molecular weight ($M_n = 2632$) shows lower T_m than T_m of PU with higher M_n . The results indicate that the crystals obtained in PU-142 during crystallization are larger than those developed in PUs with lower content of soft segments (Table 2). The presence of hydrogen bonding between the hard and soft segments restricts the phase separation and ordering (crystallization) of PUs. When the soft segment length increases from 2632 to 16472, the reduction in the degree of connectivity between the hard and soft segments should make the phase separation process and crystallization easier. These peaks could be related to HDI/BD hard segments which have a regular repeat structure capable of high degree of hydrogen bonding, exhibit very sharp endothermic peaks at higher temperatures about 290°C. DSC thermograms for all samples indicate that an increase in molar ratio of ϵ -caprolactone to BHETA changes the size and peak position temperature of the endotherms above 280°C.

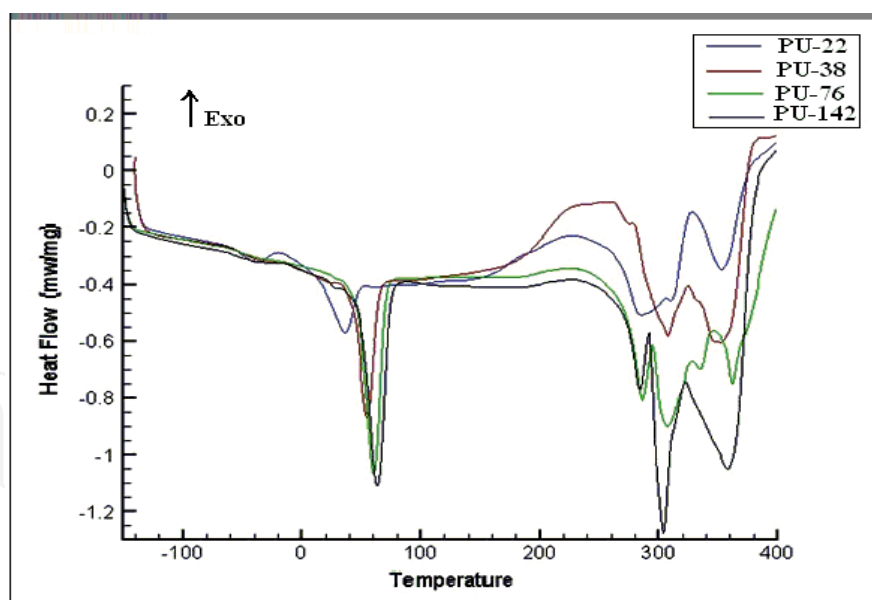

Fig. 19. DSC thermograms of PU-22 to PU-142.

Longer soft segments produce better phase-separated systems which caused to form more readily sharp peaks as indicated by the trend in phase separation with increasing soft segment length at 290°C. However, these endothermic peaks may be thought to arise from the disruption of ordered, non-crystalline hard-segment aggregates. As shown in Fig. 19, as the lengths of soft segments increases, T_g of polyurethane decreases due to more flexibility

of soft segments chains. Caprolactone-based polyurethane shows T_g at -54°C by DSC method for polycaprolactone with M_n about 2000 g/mol. Presence of BHETA in the chemical structure results in increasing of T_g in our work.

6.2.3 DMTA results

DMTA Results are shown in Figs. 20 and 21 for PU-22 and PU-38 respectively. Two main transitions are present in the DMTA spectra: a first peak (T_β) located in the low-temperature region (at about -75°C and -85°C) and a second peak (T_α) seen in a higher temperature region (at about -25°C). Increasing in soft segments length caused to decrease T_β of polyurethanes. The observed T_β at -75°C and -85°C which was assigned to methylene sequence local relaxations, in analogy to results reported previously, is due to relaxation of caprolactone-based soft segments. It is found clearly that T_β decreases with increasing of $-\text{CH}_2-$ units in caprolactone chains in sample PU-38 rather than PU-22.

For the assignment of T_α , we have considered a mixing-transition temperature (T_{mix}), which would be the result of the various degrees of mixing between the ester and urethane blocks.

According to this interpretation, the matrix would be formed by a PCL-rich continuous phase, in which PCL crystallites would be embedded, and amorphous PCL segments emerging from entangled domains with urethane segments would be connected to these crystallites. Some damping or fluctuations at higher temperatures is seen which corresponds to the hard-segments glass transition. As Shown in Figs. 20 & 21 E' in glassy region decreases with increasing of crystalline PCL soft segments length, whereas increases in rubbery plateau. The polymer with a higher content of PCL crystalline soft segments gives a higher E' in rubbery region for PU-38 in comparison with PU-22. TGA results shows that $T_{90\%}$ and char residue decreases with increasing of molecular weight of soft segments for samples PU-22 to PU-142, which confirms decreasing in concentration of urethanes and aromatic groups in the samples. Also, presence of aromatic ring due to BHETA led to increasing of thermal stability.

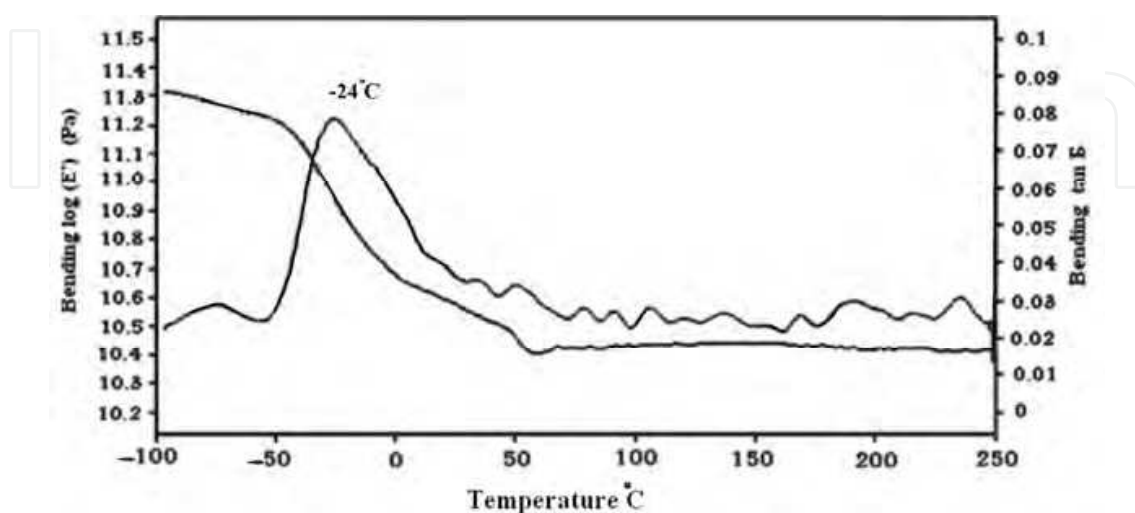

Fig. 20. DMTA thermogram of PU-22.

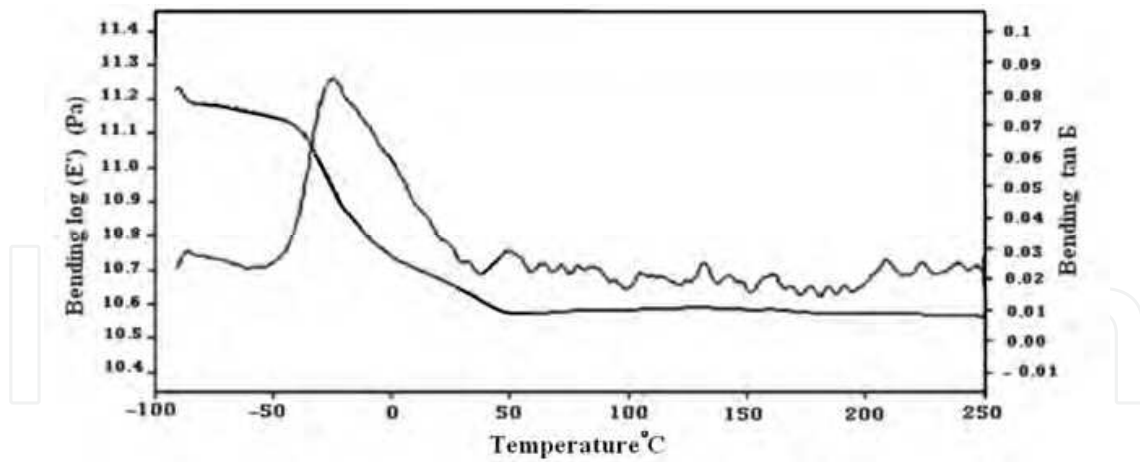

Fig. 21. DMTA thermogram of PU-38.

6.2.4 Optical Microscopy (OM) and Scanning Electron Microscopy (SEM)

Optical microscopy (OM) images shown in Fig. 22 illustrate the morphology of the synthesized PUs (scale bar shows 30 microns). OM results show rather smooth and rather rough structures for samples PU-22 and PU-38, while are fibrous-looking for PU-76 and PU-142.

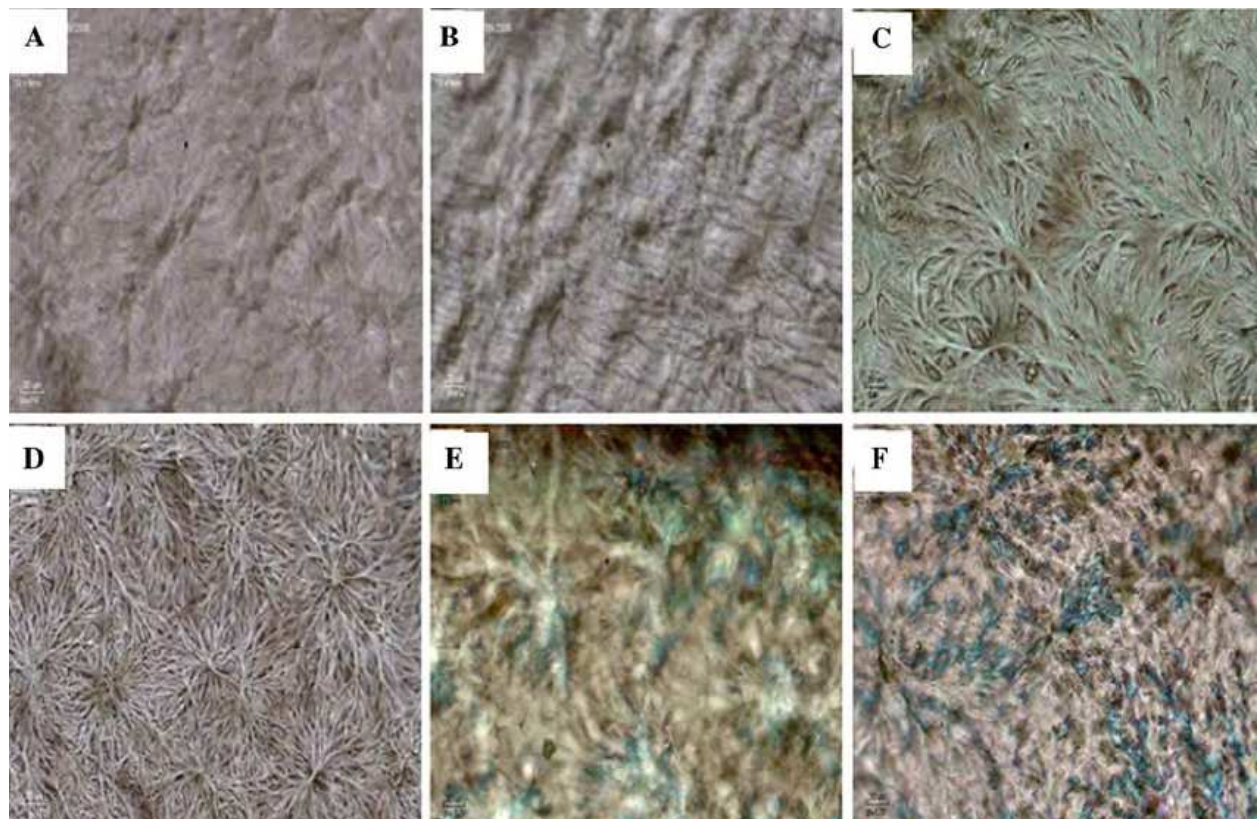

Fig. 22. Optical microscopy images: (a) PU-22; (b) PU-38; (c) PU-76; (d) PU-142; (e) Disordered PU-76; (f) disordered PU-142.

Comparison shows as the soft segment length increases, the tendency to crystallization increases and formation of different structures is observed clearly. Circular regions with 200 μm diameters are seen for PU-142. DSC results confirm the presence of crystallites with sharp melting points from 36°C-63.6°C, which could be correlated to these structures. Rough structures are seen for samples PU-142 and PU-76, whereas PU-22 and PU-38 are less high. SEM results confirm the observed phenomena in OM images. Structures formed in the order of magnitude of *ca*10-100 nm and as M_n of soft segments increases, domains are larger.

6.2.5 Tensile strength and biodegradability study

Tensile strength and elongation at break of samples, before and after biodegradability tests, is shown in Figs. 23.a and 23.b which shows that elongation at break of PU-22 and strength of PU-38 has the highest values respectively.

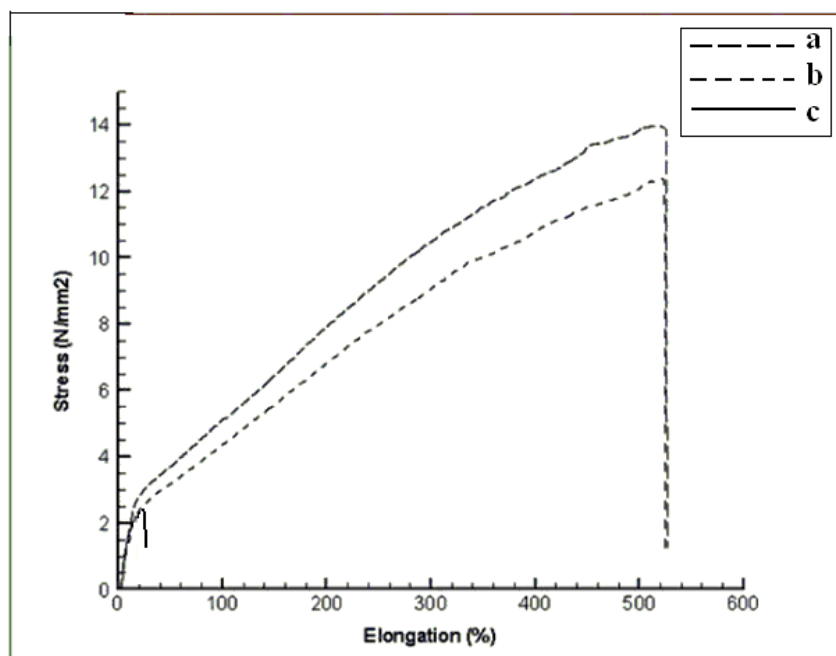

Fig. 23. a-Stress-Strain curves of PU-22: (a) Before biodegradability test; (b) after biodegradability test (3 days in compost); (c) after biodegradability test (20 days in compost).

In contrast, elongation at break of PU-142 and PU-76 are lower than others dramatically. As shown in Fig. 24, PU-22 and PU-38 show elastomeric behavior. Of course, PU-38 shows necking; this isn't seen for PU-22, PU-76 and PU-142 show brittle behavior. Fig. 25 shows schematic chemical structures of PU-22 to PU-142. The observed necking could be correlated to extension of chain folding in chemical microstructure of PU-38 under constant force (Fig.25b). Very low strengths in samples PU-76 and PU-142 compared to PU-22 and PU-38 (Fig.25) are due to low concentration of urethane linkages and hydrogen bonding. More strength for PU-142 than PU-76, which is related to the soft segment molecular weight of this sample ($M_n=16472$ g/mol) that is more than entanglement molecular weight (M_e) of polycaprolactone diol as *ca* 8000 g/mol.

The presence of BHETA leads to lower flexibility in polyol chain and finally higher M_e in comparison to virgin polycaprolactone equal to *ca* 8000g/mol. The presence of BHETA leads

to lower flexibility in polyol chain and finally higher M_e in comparison to virgin polycaprolactone. Therefore, M_n of Polyol-76 (8720 g/mol) is lower than M_e of BHETA containing polyols. The presence of entanglement in polymeric chains provided higher strength for this sample (Fig.25.c and Fig.25.d). It is interesting to obtain good tensile properties for synthesized polyurethanes in this study (especially for PU-22 and PU-38 which show higher hydrogen bonding confirmed by FTIR. This is explained by the fact that ordering degree of PCL blocks increases, and they are capable of forming crystalline structures, which promotes growth of their tensile strength and Young's modulus. It is noticeable that PU-22 and PU-38 were formulated without chain extender. Mechanical properties of novel polyurethanes in this work are comparable with similar commercial polyurethanes that already available. In this research we choose tensile test because of rapid biodegradation of samples and impossibility to weigh during and after decomposition. In order to compare

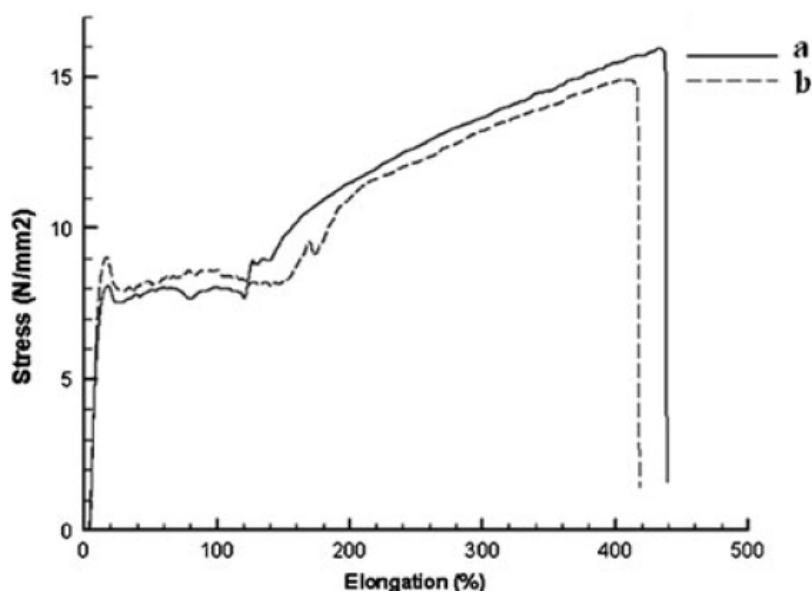

Fig. 24. b-Stress-Strain curves of PU-142: (a) before; (b) after biodegradability.

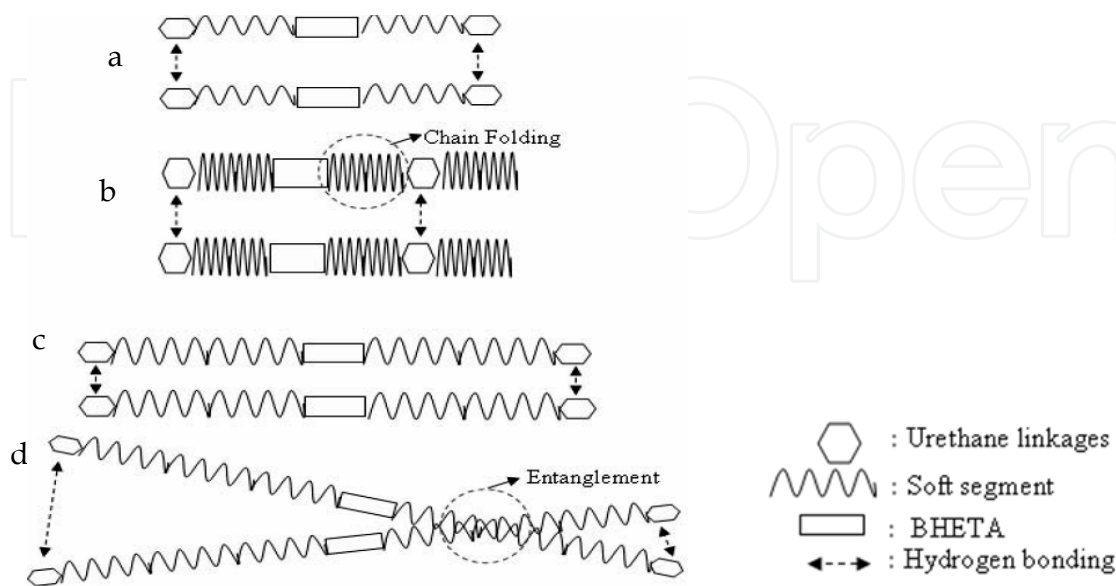

Fig. 25. Schematic chemical structures of PU-22 to PU-142.

biodegradability of polyurethanes, dumbbells of various samples were maintained in compost (soil, straw, leaves, etc.) at 45°C and 95% moisture and tensile strength tests have been achieved after 3 and 20 days. Stress-elongation curves of PU-22 to PU-142, before and after biodegradability test, are shown in Figs. 23 to 24 respectively. As shown in the figures strength and elongation at break have been reduced after 3 days in all samples. After 20 days all of polyurethanes decomposed except PU-22. However, mechanical properties of PU-22 have been reduced dramatically. More resistance of PU-22 to degradation is due to more concentration of urethane groups and less concentration of carbonyl groups in the polymer chains in this sample. Biodegradability of samples is comparable to polymers based on caprolactone; however presence of BHETA affects on biodegradability obviously.

6.3 Synthesis of special polyurethanes

Novel polyurethanes were synthesized based on prepared BHETA, 1,4-Butanediol (BD), Ether type Polyol and various molar ratio of Hexamethylene Diisocyanate (HDI). To evaluate the effect of BHETA, properties of polyurethanes without and with BHETA have been compared. FTIR, thermal transitions (DSC), degradation (TGA) of synthesized PUs have been investigated. (Shamsi et al, 2009).

6.3.1 Materials and synthesis method

PET staple waste fiber consists of short fibers with density of 1.45 g cm⁻³. PET staple waste fibers were boiled with methanol for 3 h to remove any surface finishing and dirt present in the fiber mass. Ethanolamine (EA), Ether type polyol (Polyol): Mn=2000 (Bayer), Sodium acetate, 1,4-Butanediol (BD), Dibutyl Tin dilaurate (DBTDL), Hexamethylene Diisocyanate (HDI) were used as received. Polyurethanes were synthesized using a one-shot polymerization method. BHETA (0.0277 mol), Polyol (0.0119 mol), BD (0.198 mol) and DBTDL (7.78 × 10⁻⁴ mol) were dissolved in 200 mL of DMSO in a three-necked flask equipped with a condenser and stirrer. The temperature was raised to 90°C. Then desired amounts of HDI were added and the reaction mixed vigorously. In order to study the effect of BHETA on the polyurethane properties, two samples were synthesized without BHETA.

Sample	NCO/OH ratio (mol)	BD (mol)	Polyol (mol)	HDI (mol)	Reaction Time(min)	Gel Time (min)
PU-3 ^b -W ^c	3	1	0.2	3.6	-	70
PU-10 ^b -W ^c	10	1	0.2	12	6	-

$$^a \frac{\text{BD(mol)}}{\text{BHETA(mol)} + \text{Polyol(mol)}} = 5 \quad \frac{\text{BHETA(mol)}}{\text{Polyol(mol)}} = 2.33 \quad ^b \text{NCO/OH ratio in the polyurethane}$$

Table 3. Molar ratios^a of reactants to synthesis of PUs (with BHETA).

Polyol, BD and DBTDL were dissolved in 100 mL of DMF in a three-necked flask equipped with a condenser and stirrer. Then the desired amounts of HDI were added. After removing the mixtures from the reactor, they were post-cured and dried at 100°C for 8 h.

Tables 3 and 4 give the various molar ratios used in the synthesis of PU-1 to PU-10 (with BHETA) and PU-3-W and PU-10-W (without BHETA).

Sample	NCO/OH Molar ratio	BD (mol)	BHETA (mol)	Polyol (mol)	HDI (mol)	Reaction Time (min)	Gel Time (min)
PU-1 ^b	1	1	0.14	0.06	1.2	6	-
PU-5 ^b	1.5	1	0.14	0.06	1.8	-	35
PU-3 ^b	3	1	0.14	0.06	3.6	-	50
PU-4 ^b	4	1	0.14	0.06	4.8	6	-
PU-7 ^b	7	1	0.14	0.06	8.4	6	-
PU-10 ^b	10	1	0.14	0.06	12	6	-

a $\frac{\text{BD(mol)}}{\text{Polyol(mol)}} = 5$ b: NCO/OH ratio in the polyurethane C: polyurethane without BHETA

Table 4. Molar ratios of reactants to synthesis of PUs (without BHETA).

6.3.2 FTIR analysis of polyurethanes

As seen in the spectra of PU-3, PU-10 and PU-3-W (Fig. 26), strong inter-urethane hydrogen bonding is developed for all samples. Participating N-H group the hydrogen bond and non-bonded N-H group absorption displays a characteristic absorption band between 3300 and 3446 cm^{-1} and 3446 cm^{-1} respectively. FTIR spectrum of polyurethanes would display two carbonyl bands: one at 1707 cm^{-1} assigned to bonded C-O groups, and a second at 1731 cm^{-1} assigned to free C-O groups.

6.3.3 Thermal analysis

DSC and TGA results are shown, respectively, in Figs. 28a and 28b for samples PU-3 and PU-3-W. Comparison of DSC thermograms of PU-3 and PU-3-W shows the first endothermic peak at 150°C for PU-3-W, whereas it is at 190°C for PU-3 due to presence of BHETA in the chemical structure. DSC Thermograms in Figures 28a and 28b show exothermic peaks for PU-3-W and endothermic peaks for PU-3.

Exothermic crosslinking reactions are due to the thermodynamically favorable conformation that such interchain covalent bonds would promote. Conversely, the destruction of interchain hydrogen bonding, chain scission and pyrolysis reactions cause a DSC endotherm. The bond dissociation energy for a carbon-carbon single bond is relatively high (ca 375 kJ mol^{-1}) and bond scission is endothermic.

Conversely, for PU-3-W, crosslinking reactions predominate over destruction of urethane hydrogen bonding and chain scission. Dissociation or chain scission reactions in thermal degradation mechanisms of polyurethanes were summarized by Saunders *et al.* in four types of reactions that may take place during thermal degradation: (i) Dissociation to isocyanate and alcohol; (ii) formation of primary amino and olefin; (iii) formation of secondary amine; and (iv) transesterification-type bimolecular displacement. Therefore chain scission reactions in samples PU-3-W and PU-3 are indeed as shown in Fig 27. It has been shown

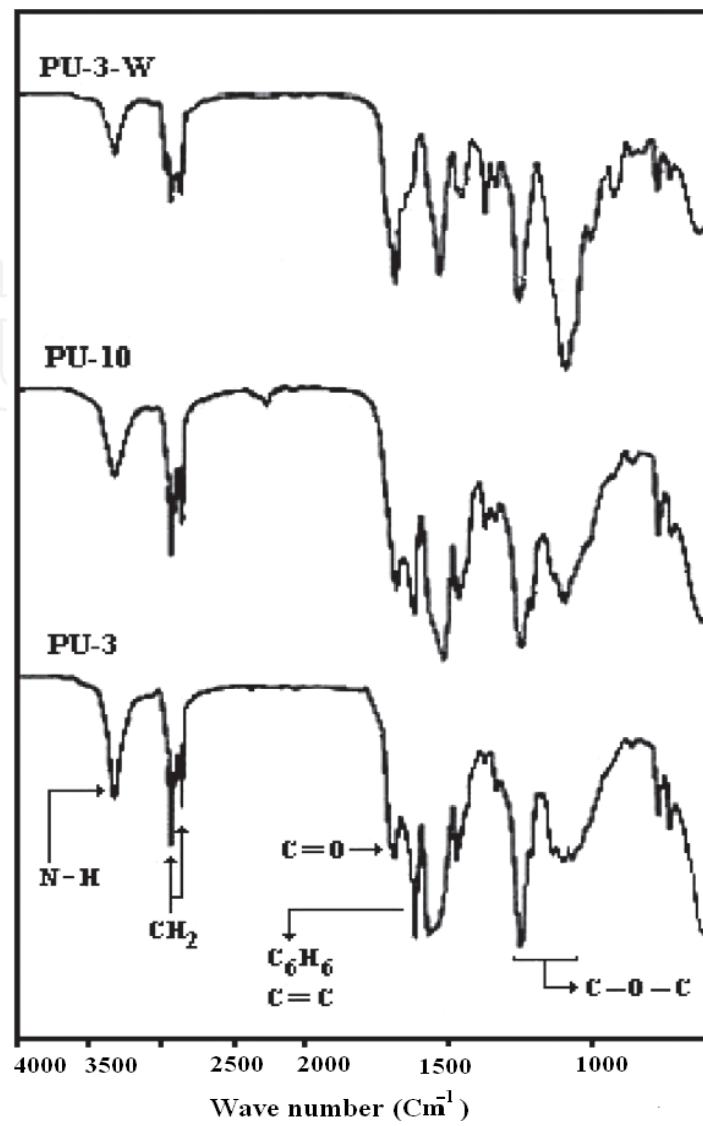
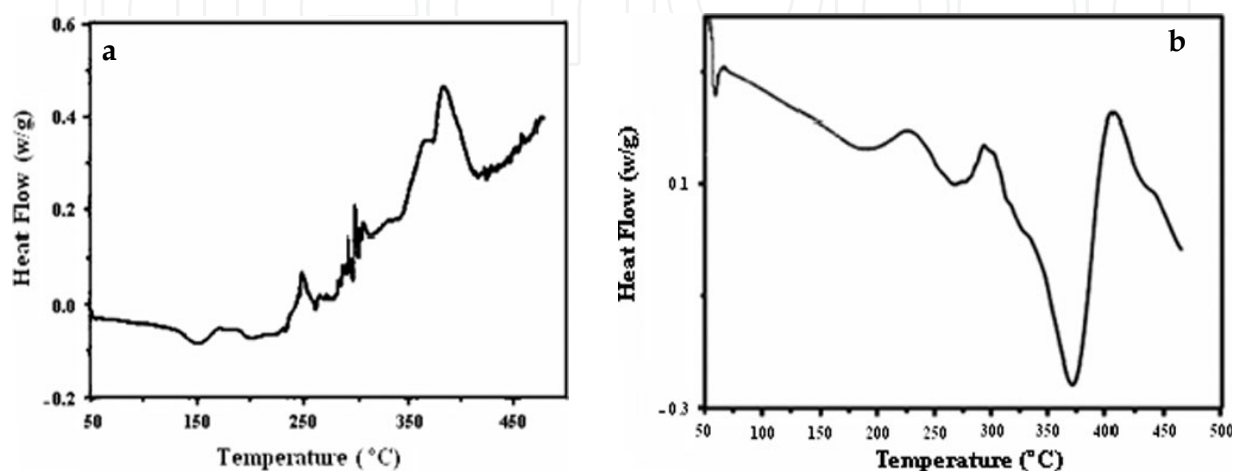

Fig. 26. FTIR spectra of PU-3, PU-10 and PU-3-W.



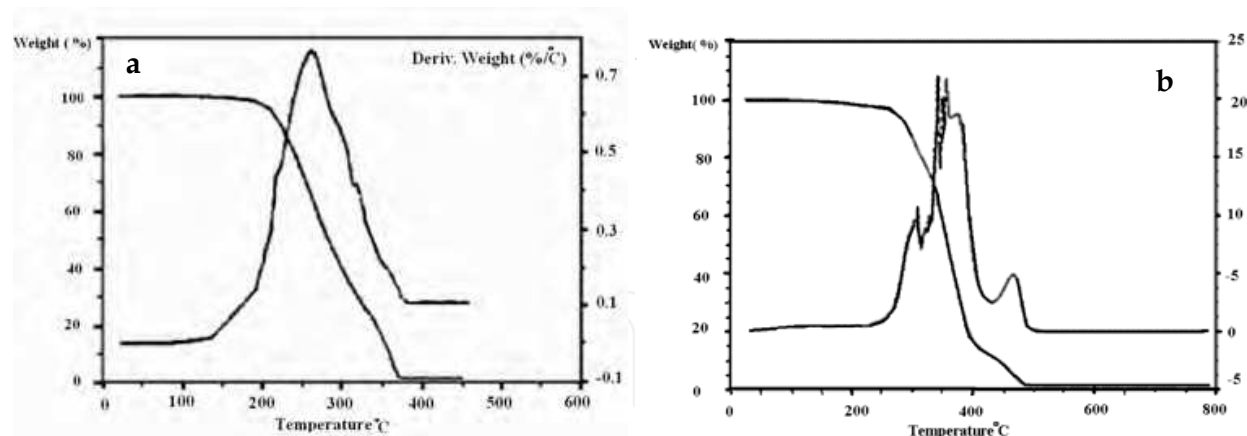

Fig. 27. DSC and TGA thermograms of (a) PU-3-W and (b) PU-3.

that the endothermic behavior (T2 peak) is dissociation and degradation, resulting from long-range ordering and disordering of the hard segment domains in segmented polyurethanes. Some endothermic thermal transitions in DSC analysis of polyurethanes are due to structural decomposition of the polymer. As seen from the TGA and differential TGA (DTGA) thermograms (Figs 27(a) and (b)), weight reduction in PU-3-W begins at 140°C while it starts at about 235°C for PU-3. The first, second and third peaks in the DTGA trace of PU-3 are related to chain scission of urethane linkages, Polyol and BHETA, and isocyanurate and carbodiimide, respectively. 38 Also, the composition of various products was calculated as 20, 68 and 10.3 wt%, respectively. TGA of sample PU-3-W shows continuous degradation, while in PU-3 three-step degradation is observed.

Sample	T _{initial}	T _{25%}	T _{50%}	T _{75%}	T _{90%}	Char residue at 500 C (Wt. %)
PU-3 ^a	232	330	360	385	445	1.7
PU-3 ^a -W ^b	138	249	284	333	360	0.8

Table 5. Initial, 25%, 50%, 75% and 90% decomposition temperatures, and char residues.

The presence of BHETA in the chemical structure of polyurethane (due to longer chain extender and more hydrogen bonding in polyurethane chains) results in a shift of the beginning of degradation from 140 to 235°C and also three-step degradation. As shown in Table 5, the presence of the BHETA aromatic ring causes retardation of degradation. Also, a char residue of about 1.7 wt% is seen for PU-3 and 0.8 wt% for PU-3-W.

6.3.4 Tensile shear strength

Strength measured as maximum load (F_m) of samples PU-4, PU-7, PU-10 and PU-10-W (applied on aluminum and iron substrates) is given in Table 6. As can be seen, addition of BHETA to polyurethane caused an increase of F_m and elongation for both Fe-Fe and Al-Al substrates specifically. The surface preparation method (hand abrasion) for both Fe-Fe and Al-Al substrates was identical; therefore it can be concluded that the presence of BHETA causes stronger bonding as opposed to samples without BHETA. Strong bonds between the

surface of the metal and polyurethane films, such as hydrogen bonds, are likely to be due to -NH groups in BHETA.

(1) Dissociation to isocyanate and alcohol



(2) Formation of primary amine and olefin

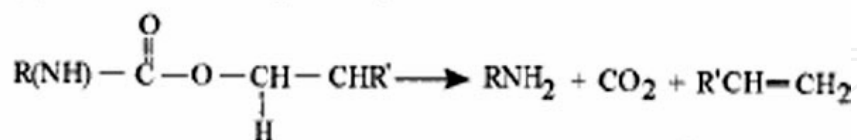

(3) Formation of secondary amine

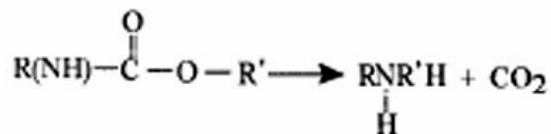

(4) Transesterification type bimolecular displacement

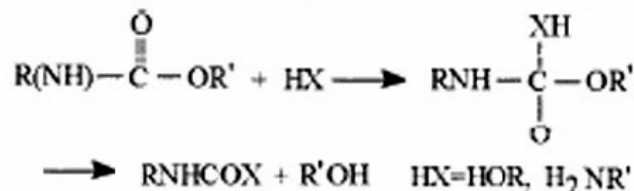

Fig. 28. Probable reactions in the degradation of polyurethanes.

Sample	NCO/OH Ratio (mol)	Maximum load on Fe-Fe (N)	Maximum load on Al-Al (N)
PU-1 ^a	1	-	-
PU-5 ^a	1.5	-	-
PU-3 ^a	3	-	-
PU-4 ^a	4	2822.63	2168.13
PU-7 ^a	7	2378	1959
PU-10 ^b	10	3054.63	1968
PU-3 ^a -W ^b	3	-	-
PU-10 ^a -W ^b	10	1092.18	806.42

Table 6. shows that the maximum loads for substrates Al-Al.

Figs 29-30 show load-deformation curves for, respectively, PU-4, PU-7 for both substrates. The load-deformation curves of the polyurethanes show brittle failure for Al-Al substrate as well as for Fe-Fe and Fe-Fe are different. The highest value of F_m (3054 N) is observed for sample PU-10 on Fe-Fe substrate. Comparison of the maximum load for sample PU-10 with commercial epoxy and polyester-type adhesives shows a 2.03- and 2.34-fold increase,

respectively. As can be seen in Table 6, the lowest F_m value is for PU-3-W on Al-Al substrate. Comparison of F_m for Fe-Fe and Al-Al samples shows higher values for the former.

This relates to higher mechanical interlocking due to the higher porosity of iron. The data obtained in the adhesion evaluation tests show a variation in F_m for both substrates. The polyurethanes used have various NCO/OH molar ratios. Therefore F_m can be related to free isocyanate groups. However, other parameters such as surface preparation method, moisture, evaporation of solvent, post-curing conditions, also affect the results.

6.3.5 Swelling behavior

The swelling behavior of samples PU-3 to PU-10 with different solvents (DMSO, DMF, EA and Tol) was investigated at room temperature. The measured values of the polymer densities were in the range 1.13–1.2 g cm⁻³. Fig. 31 shows that the swelling ratio decreases with increasing NCO/OH ratio. Increasing the NCO/OH ratio also increases the crosslinking density, consequently causing a decreasing of the swelling ratio. As regards the effect of the solvent on the swelling ratio, it is seen that an increase of solubility parameter increases the swelling ratio for all NCO/OH ratios (solubility parameters (in (cal.cm⁻³)^{0.5}) are: DMSO, 12.87; DMF, 12.1; EA, 9.1; Tol, 8.9).

6.4 Synthesis of high modulus polyurethanes

Polyurethanes have been synthesized based on BHETA, HDI and polyethylene glycol via prepolymer method. Since catalyst and raw materials have low price, synthesis of BHETA is economical and could be used as diol to synthesis of polyurethanes. In this search, polyurethanes have been synthesized based on BHETA, HDI and polyethylene glycol via prepolymer method. TGA and DSC were carried out to study thermal stability, thermal transitions, T_m and T_g of synthesized polyurethanes. Effect of BHETA content in the main chain on thermal stability of polyurethanes, strength and stiffness has been evaluated. (Mohammadi et al,2010)

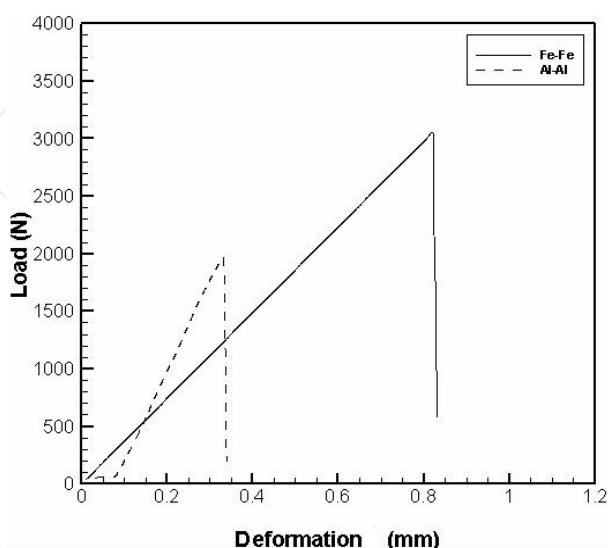

Fig. 29. Load–deformation curves for PU-4 on both substrates.

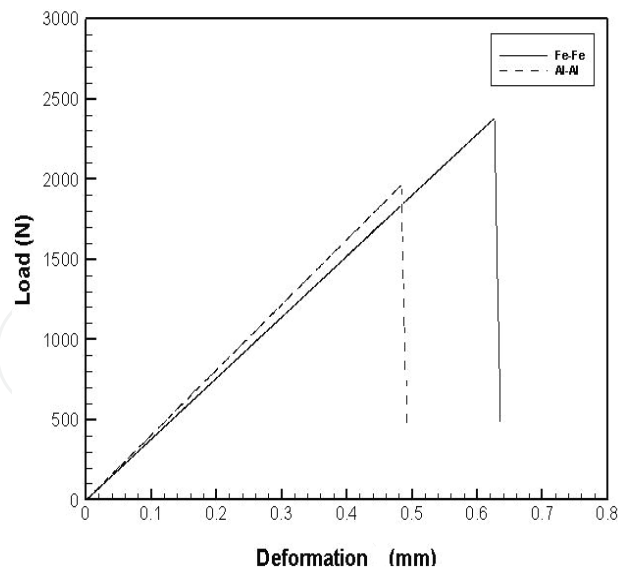

Fig. 30. Load-deformation curves for PU-7 on both substrates.

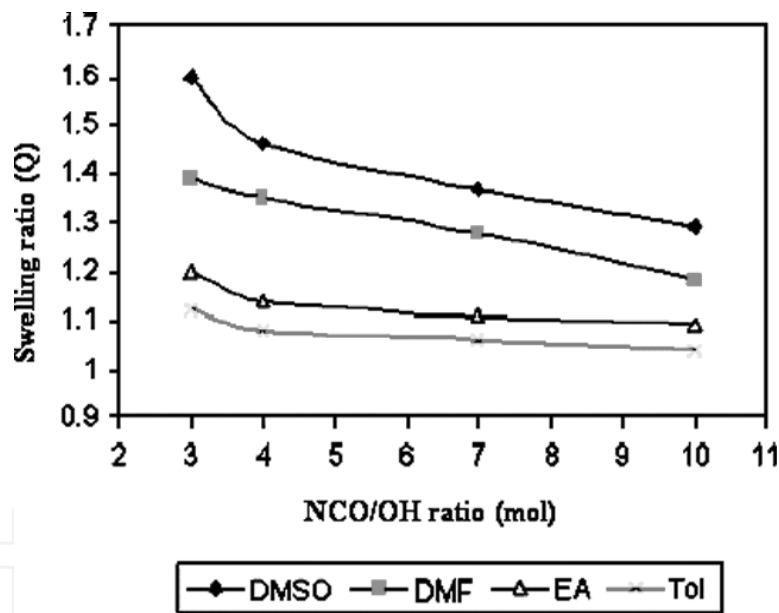

Fig. 31. Swelling ratio as a function of NCO/OH ratio for various solvents.

6.4.1 Synthesis and characterization

A 250 mL round-bottom flask equipped with a temperature controller, magnetic stirrer, reflux condenser, an N_2 inlet, charged with Hexamethylene diisocyanate isocyanate(HDI), polyethylene glycol 1000 (PEG), DMF and Di-butyl Tin Dilaurate (DBTDL) (catalyst 1 wt%). HDI and PEG were reacted for 2 h at $75^\circ C$. The obtained prepolymer, then subjected to further reaction with BHETA. The reaction time was 3 h at $70^\circ C$. Molar ratio was fixed at 1.1. The mixtures then were immediately cast on Teflon plates and then were kept in oven for 72 h at $70^\circ C$. Details of synthesis and method of synthesis are given in Table 7 and Fig. 32.

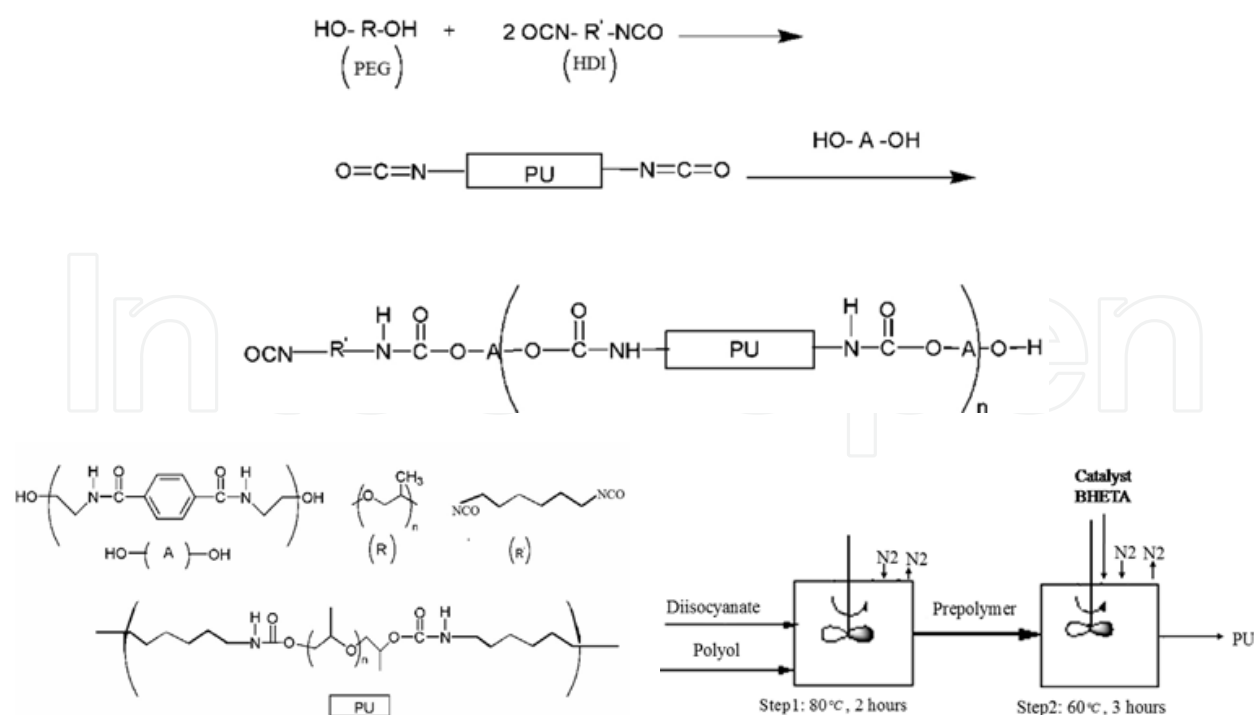

Fig. 32. Synthesis method for PUs.

6.4.2 Chemical resistance & solubility tests

The test results of chemical resistant are shown in Table 8. Polyurethanes were soluble in DMF and DMSO and they were resistant in basic media (50wt %), of course with increasing BHETA, chemical resistance of polyurethane decreases. Aromatic ring leads to increasing distance between chains, therefore chemicals can penetrate in polymer matrix easily and the polyurethane decomposes rapidly.

Sample	PEG (mol)	HDI (mol)	BHETA (mol)	Hard Segment Content
PU53 ^a	1	2.75	1.5	53.35
PU46 ^a	1	2.2	1	46.54
PU42 ^a	1	1.91	0.739	42
PU32 ^a	1	1.42	0.29	32.49

Table 7. Description of Samples and a indicates hard segment content of polyurethanes.

Sample	H ₂ SO ₄ 98 wt%	Dense HNO ₃	50 wt% NaOH	23 wt% NaCl
PU53	---	---	++	++
PU46	---	---	++	++
PU42	--	--	++	++
PU32	-	-	++	++

++: resistant -: un resistant, which number of -shows rate of decomposition

Table 8. Results of chemical resistance tests.

6.4.3 Mechanical properties

Mechanical properties of synthesized polyurethanes are shown in Table 9. The results indicate that increasing of chain extender leads to increasing of strength and stiffness of polymer and decreasing in elongation at break. For example modulus increases from 106.37 MPa to 296.16 MPa in the samples PU46 and PU53 respectively. In fact, the BHETA has an important role in strengthening of polyurethane by increasing of hydrogen bonding (since BHETA has many sites for formation of hydrogen bond) between polyurethane chains effectively. As seen in the Fig. 33 modulus and strength of polyurethanes increases with increasing of BHETA content. As shown in Fig. 34, content of BHETA affect on behavior of stress-strain curve for synthesized polyurethane under tension. It seems elastic region of the curves increases as BHETA content increases.

Sample	Young's modulus (MPa)	Max Stress (MPa)	Elongation at Break (%)
PU 53	296.16	9.18	45.82
PU 46	106.37	6.94	31.13
PU 42	62.68	5.72	51.99
PU 32	28.569	2.98	128.56

Table 9. Mechanical properties of samples contain different hard segment content.

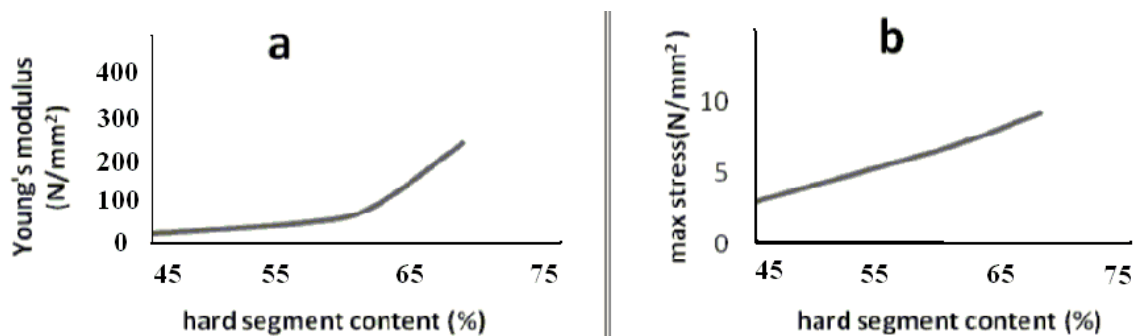

Fig. 33. Young's modulus (a) and max stress (b), as a function of hard segment content.

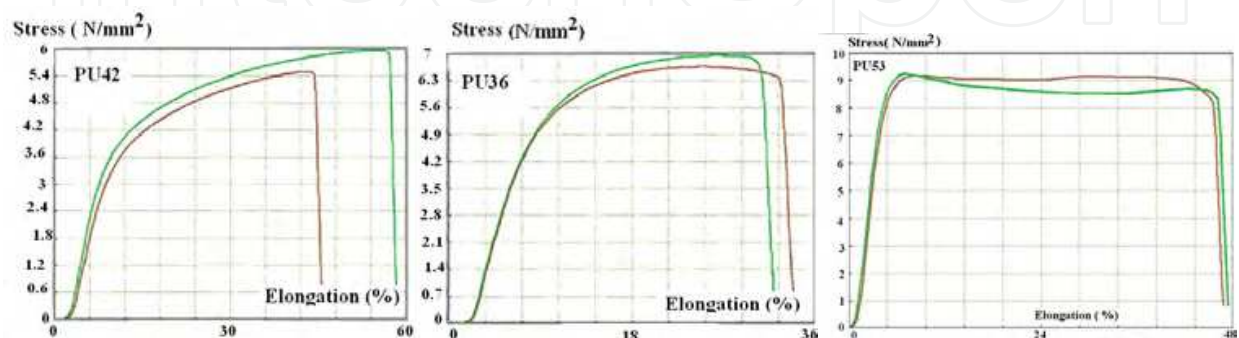

Fig. 34. Stress-Strain curves for PU42, PU46, and PU53: Two samples for each test).

6.4.4 DSC analysis

Thermoplastic segmented polyurethanes display several thermal transitions. The soft phase, responsible of the properties at low temperatures, shows glass and melting transition (if semicrystalline), while the hard phase is responsible of the properties at high temperatures showing multiple melting transitions depending on the hard segment content in the matrix. As can be seen DSC graphs of the PU42 and PU46 shown in Fig. 35, one peak at -21.6 °C and -21.18 °C are appearance for PU42 and PU46, respectively. The peak appearing at the lower temperature might be associated with a soft segment glass transition temperature (T_{gss}). The destruction of interchain hydrogen bonding caused to a DSC endotherm. It seems that the peak at about 142 °C in both PU4 and PU46 is related to breaking of hydrogen bonding which has been occurred in PU42 more than PU46. This phenomenon can be attributed to more aromatic rings exist in PU42 per unit length of chains whereas is less in PU46, thus higher flexibility in PU42 caused to higher possibility for hydrogen bonding formation. The third peak in 179 °C and 173 °C shows formed restructuring in PU42 and PU46, respectively. Apparent endothermic peaks could result from crystal structures. As hard segment content increases, position of the endothermic peaks is shifted to higher temperatures, which is indicative of better ordered hard domain. The peak at around 237 °C and 240 °C is related to PU42 and PU46 respectively.

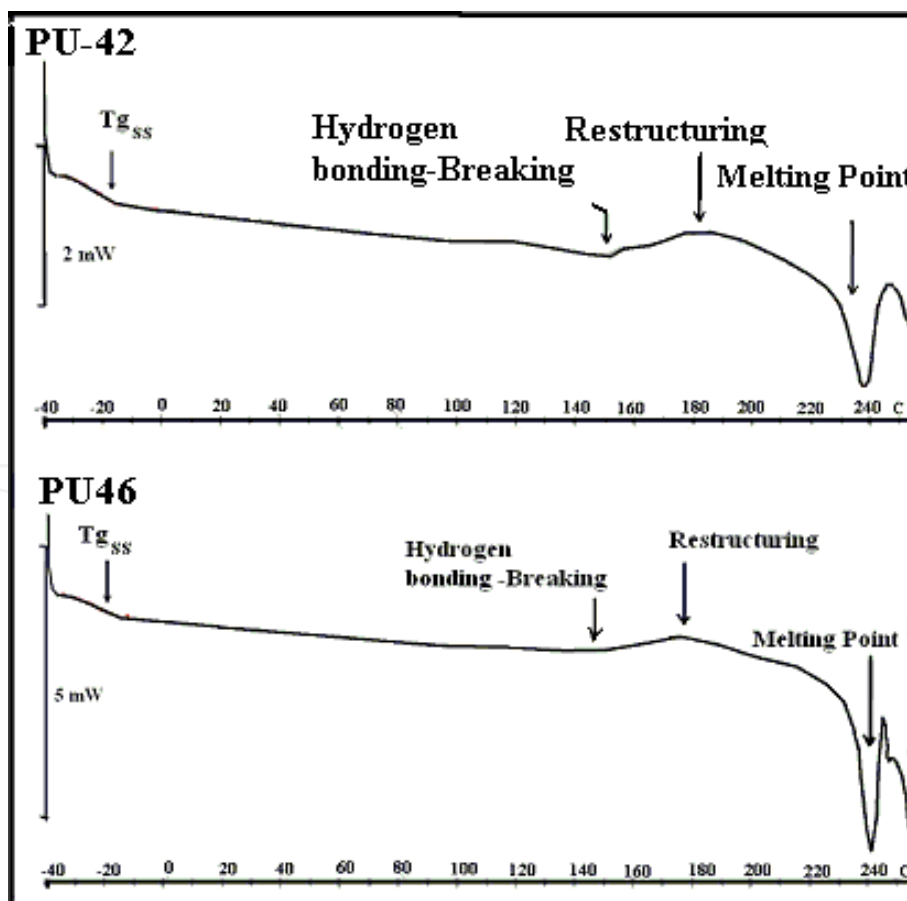

Fig. 35. DSC thermograms of PU42 and PU46.

6.4.5 TGA analysis

Polyurethanes are comparatively thermally unstable polymers; decomposition temperature of the polyurethane depends on the polyurethane structure. Polyurethane degradation usually starts with the dissociation of the urethane bond, CO_2 and isocyanate evaporation. Normally, three mechanisms of decomposition of urethane bonds have been proposed and reactions may proceed simultaneously: dissociation to isocyanate and alcohol, formation of primary amine and olefin and formation of secondary amine and carbon dioxide. Fig. 36 shows TGA curves of PU42 and PU46. The shapes of the weight loss curves of both polyurethanes are almost identical and degradation profiles of polyurethanes depend on the content of BHETA. It could be described with different values which are bringing in Table 10. Initial degradation temperature of PU42 is much higher than that of PU46. Generally, reduction of T_{id} for PU46 may be attributed to these facts: at first flexibility can be affected on hydrogen bonding formation; PU42 is more flexible which leads to increase probability of hydrogen bonding formation as, mentioned in DSC tests.

Sample	T_{id} °C	T10% °C	T20% °C	T30% °C	T50% °C	Char Residue (%)	DTG (Max Temp.) °C
PU 42	201	232	245	256	368	2.534	240
PU 46	172	203	220	233	351	5.100	250

Table 10. Results of the thermo gravimetric analysis of samples.

Second reason; as seen in DSC thermograms restructuring phenomenon occurred at about 170°C. It seems, in the case of PU42 restructuring is predominant rather to decomposition reactions, in restructuring phenomenon new bonds formed, that leads to higher thermal stability in PU42.

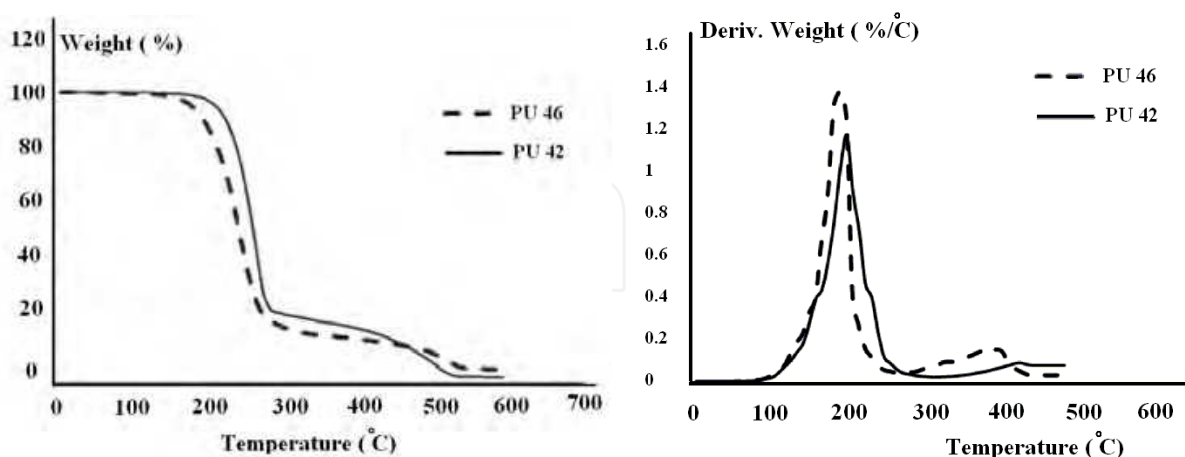

Fig. 36. TGA and DTG thermo grams for PU46 and PU42.

7. Conclusions

Recycling of polyethylene terephthalate (PET) by aminolysis breeds environmental benefits. There are few reports on the usage of recycled BHETA from PET to synthesis of

polyurethanes. At first use of ethanolamine for aminolytic degradation of PET waste has been investigated. Obtained product, BHETA has potential for further reactions to synthesize useful products such as polyurethanes which have important industrial applications. In our studies, BHETA has been used as an intermediate to produce useful materials based on PET waste. At first study, ring opening polymerization of caprolactone by BHETA was carried out and polyols with different M_n have been synthesized and then polyurethanes have been synthesized using above mentioned polyols. Increasing of M_n polycaprolactone diol leads to regular increasing in melting point, crystallinity and fusion heat of samples, tendency to crystallization and formation of ordered structures is observed clearly which confirm by SEM and OM. Thermal degradation is serious for the sample containing lowest aromatic concentration. Elongation at break of 4.7 to 520% and strength of 9.3 to 16 MPa for synthesized polyurethanes without chain extender has been obtained. Biodegradability tests show high rated biodegradation for all polyurethanes.

In second study, BHETA has been used as an additional chain extender to synthesize novel segmented polyurethanes used in adhesives and coatings. Strong hydrogen bonding was evident from the FTIR spectra for all synthesized polyurethanes (with and without BHETA). Different thermal behavior for polyurethanes with and without BHETA have been observed using TGA due exothermic or endothermic reactions during their degradation. Addition of BHETA to the polyurethanes caused an increase in maximum load (F_m) and elongation for both Fe-Fe and Al-Al substrates. Comparison of the F_m for the synthesized adhesive with those of commercial epoxy and polyester-type adhesives shows a 2.03 and 2.34-fold increase, respectively. Chemical resistance tests show a high resistance of the polyurethanes to alkaline, NaCl and water media, but a lower resistance in high-concentration acids.

In third study BHETA uses instead of common chain extenders to synthesize of novel segmented polyurethanes. BHETA has an important role in strengthening of polyurethane, increasing of BHETA content caused to obtain modulus as 300 Mpa, Maximum stress as 9.18 Mpa. Using of BHETA in production of polyurethane leads to obtain polyurethanes with suitable phase separation and mechanical properties, decrease in raw material costs as well as green environment based on a PET waste recycled material.

8. References

- [1] Kloss J, Fernanda SM, Souza D, Edilsa R, Silva D, Jair Alves D, 656 Leni A, Sonia Faria Z (2006) *Macromol Symp* 245–246: 651–656
- [2] Shukla SR, Harad AM, Jawale LS (2009) *Polym Deg Stab* 94: 604–609.
- [3] Sivaram S, (1997) National seminar on recycling and plastics waste management, Sep:283–8.
- [4] Barbozaa ES, Lopez DR, Amico SC, Ferreira CA (2009) *Resour Conserv Recy* 53:122.
- [5] Pusztaszeri SF (1982) US Patent 4355175.
- [6] Mishra S, Goje AS, Zope VS (2003) *Poly Plastics Technol Eng* 42(4): 581–603.
- [7] Mishra S, Goje AS, Zope VS (2003) *Polym React Eng* 11(1): 79–99.
- [8] Schwartz J (1995) US Patent 5395858.
- [9] Lamparter RA, Barna BA, Johnsrud DR (1985) US Patent 4542239.
- [10] Tindall GW, Perry RL (1991) US Patent 5045122.

- [11] Mishra S, Goje AS (2003) *Polym React Eng* 11(4): 963–987.
- [12] Doerr ML (1986) US Patent 4578510.
- [13] Yang Y, Lu Y, Xiang H, Xu Y, Li Y (2002) *Polym Degrad Stabil* 75: 185–191.
- [14] Motonobu G, Hiroshi K, Akio K, Tsutomu H, Shoji N(2002) *J Phys Con. Mat*, 14(44):11427–30
- [15] Motonobu G, Hiroshi K, Akio K, Tsutomu H, Shoji N, McCoy BJ(2002) *Alche J* 48(1):136–44
- [16] Akiharu F, Minako S, Masashige M (1986) US Patent 4609680.
- [17] Ostrowski HS (1975) US Patent 3884850.
- [18] Güçlü G, Kasgöz A, Özbudak S, Özgümüş S, Orbay M (1998) *J Appl Polym Sci* 69(12):2319.
- [19] Andrej K (1998) *J Appl Polym Sci* 69(6–8): 1115–1118.
- [20] Berti C, Colonna M, Fiorini M, Lorenzetti C, MarchesP(2004) *Macromol Mater Eng* 289:49–5
- [21] Manfred K, Wolfgang S, Uwe S (1993) US Patent 5266601.
- [22] Shukla SR, Harad AM (2006) *Polym Degrad Stab* 91: 1850–1854.
- [23] Fabryc y E, Leistner A, Spsychaj T (2000) *Adhesion*. 44(4): 35.
- [24] Zahn H, Pfeifer H (1963) *Polymer* 4: 429–32.
- [25] Popoola V (1998) *J Appl Polym Sci* 36: 1677–83.
- [26] Blackmon KP, Fox DW, Shafer SJ (1990) US Patent 4973746.
- [27] Shamsi R, Abdouss M, Mir Mohamad Sadeghi G, Afshar Taromi (2009) *Polym Int* 58:22–30
- [28] Mohamadi, M; Mir M Sadeghi, G. & Abdouss M. (2010) *Mat-WissU Werkstofftech*, 41, 8:682–88
- [29] Mir M. Sadeghi G, Shamsi R, Sayaf M, *J Polym. Environ*, DOI 10.1007/s10924-011-0283-7
- [30] www.chemsysytem.com, nexant (2009), PERP 07/08-5:1-8
- [31] Yeganeh H, Jamshidi H, Jamshidi S (2007) *Polym Int* 56: 41–49
- [32] Heijka R, Calck R, Tien T, Buma P, Penni A, Vet RPH(2005) *J Schouten: Biomat* 26: 4219–28.

IntechOpen

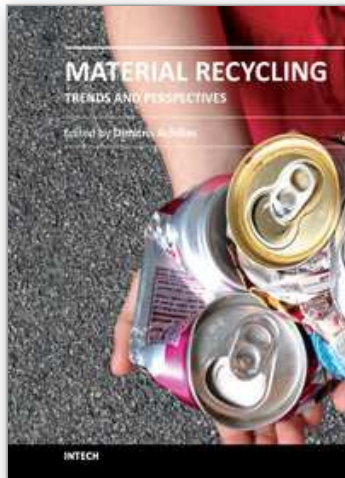

Material Recycling - Trends and Perspectives

Edited by Dr. Dimitris Achilias

ISBN 978-953-51-0327-1

Hard cover, 406 pages

Publisher InTech

Published online 16, March, 2012

Published in print edition March, 2012

The presently common practice of wastes' land-filling is undesirable due to legislation pressures, rising costs and the poor biodegradability of commonly used materials. Therefore, recycling seems to be the best solution. The purpose of this book is to present the state-of-the-art for the recycling methods of several materials, as well as to propose potential uses of the recycled products. It targets professionals, recycling companies, researchers, academics and graduate students in the fields of waste management and polymer recycling in addition to chemical engineering, mechanical engineering, chemistry and physics. This book comprises 16 chapters covering areas such as, polymer recycling using chemical, thermo-chemical (pyrolysis) or mechanical methods, recycling of waste tires, pharmaceutical packaging and hardwood kraft pulp and potential uses of recycled wastes.

How to reference

In order to correctly reference this scholarly work, feel free to copy and paste the following:

Gity Mir Mohamad Sadeghi and Mahsa Sayaf (2012). From PET Waste to Novel Polyurethanes, Material Recycling - Trends and Perspectives, Dr. Dimitris Achilias (Ed.), ISBN: 978-953-51-0327-1, InTech, Available from: <http://www.intechopen.com/books/material-recycling-trends-and-perspectives/from-pet-waste-to-novel-polyurethanes>

INTECH
open science | open minds

InTech Europe

University Campus STeP Ri
Slavka Krautzeka 83/A
51000 Rijeka, Croatia
Phone: +385 (51) 770 447
Fax: +385 (51) 686 166
www.intechopen.com

InTech China

Unit 405, Office Block, Hotel Equatorial Shanghai
No.65, Yan An Road (West), Shanghai, 200040, China
中国上海市延安西路65号上海国际贵都大饭店办公楼405单元
Phone: +86-21-62489820
Fax: +86-21-62489821

© 2012 The Author(s). Licensee IntechOpen. This is an open access article distributed under the terms of the [Creative Commons Attribution 3.0 License](#), which permits unrestricted use, distribution, and reproduction in any medium, provided the original work is properly cited.

IntechOpen

IntechOpen