

# We are IntechOpen, the world's leading publisher of Open Access books Built by scientists, for scientists

**4,800**

Open access books available

**122,000**

International authors and editors

**135M**

Downloads

Our authors are among the

**154**

Countries delivered to

**TOP 1%**

most cited scientists

**12.2%**

Contributors from top 500 universities



**WEB OF SCIENCE™**

Selection of our books indexed in the Book Citation Index  
in Web of Science™ Core Collection (BKCI)

Interested in publishing with us?  
Contact [book.department@intechopen.com](mailto:book.department@intechopen.com)

Numbers displayed above are based on latest data collected.

For more information visit [www.intechopen.com](http://www.intechopen.com)



# The Power of Molecular Genetics in Establishing the Diagnosis and Offering Prenatal Testing: The Case for Alport Syndrome

Constantinos Deltas<sup>1\*</sup>, Konstantinos Voskarides<sup>1</sup>,  
Panagiota Demosthenous<sup>1</sup>, Louiza Papazachariou<sup>1</sup>,  
Panos Ziropiannis<sup>2</sup> and Alkis Pierides<sup>3</sup>

<sup>1</sup>*Molecular Medicine Research Center and Laboratory of Molecular and Medical Genetics  
Department of Biological Sciences, University of Cyprus*

<sup>2</sup>*Athens General Hospital "G. Gennimatas"*

<sup>3</sup>*Department of Nephrology Hippocrateon Hospital, Nicosia*

<sup>1,3</sup>*Cyprus*

<sup>2</sup>*Greece*

## 1. Introduction

Most Alport cases, 85%, are caused by mutations in the X-linked gene, *COL4A5* that encodes the  $\alpha 5$  chain of type IV collagen, the most abundant structural protein in the glomerular basement membrane (GBM). The remaining 15% of cases are caused by autosomal recessive mutations in the genes that encode the  $\alpha 3$  and  $\alpha 4$  chains of the type IV collagen, *COL4A3*/*COL4A4* <sup>1,2</sup>. Thin basement membrane nephropathy (TBMN) is reportedly also a genetically heterogeneous condition, caused by heterozygous *COL4A3*/*COL4A4* mutations in about 40-50% of the cases. No other responsible genes have been identified as yet.

Collagen type IV, as all collagens, is a trimer formed by combinations of three of the six alpha chains,  $\alpha 1$ - $\alpha 6$ . Genes *COL4A1* and *COL4A2* map to chromosome 13q34, *COL4A3* and *COL4A4* map to chromosome 2q36-q37 and *COL4A5* and *COL4A6* map to Xq22-23. All six genes are encoded in nearly 50 exons and close to 1600 aminoacids, and consist of an N-terminal 7S domain, a C-terminal non-collagenous (NC1) domain and a large collagenous domain in between, containing the characteristic Gly-X-Y repeat, common to all collagens. All six alpha chains contain 22-26 natural interruptions of the Gly-X-Y repeats, spread throughout their central collagenous domain. These are presumably regions of specific function and/or ligand binding sequences, of significance to its structural role in the basement membrane. Although there are many possible combinations among the six alpha chains, only three are biologically compatible and found in basement membranes. These are composed of  $\alpha 1\alpha 1\alpha 2$ ,  $\alpha 3\alpha 4\alpha 5$  and  $\alpha 5\alpha 5\alpha 6$ . Type IV collagen participates in forming networks interacting with additional important components of the basement membranes, such as laminin and nidogen <sup>3,4</sup>. As a component of the glomerular filtration barrier, along

---

\* Corresponding Author

with the endothelial cells and the podocytes, basement membranes play a crucial role as a selective filter, based on molecular size and charge. A damage of the basement membrane or inherited defects such as mutations in type IV collagen lead to the abnormal passage of red blood cells in the urine. Mutations in five of the six *COL4A* chains have been linked to specific phenotypes (Table 1).

Chain	Gene	Chromosome	Disease association	References
$\alpha 1(\text{IV})$	COL4A1	13q34	Porencephaly; Brain small vessel disease with hemorrhage; autosomal dominant hereditary angiopathy with nephropathy, aneurysms, and muscle cramps (HANAC syndrome)	20-22
$\alpha 2(\text{IV})$	COL4A2	13q34	None	
$\alpha 3(\text{IV})$	COL4A3	2q36-q37	Autosomal Recessive Alport Syndrome; Autosomal Dominant Alport Syndrome; Benign Familial Hematuria and Thin Basement Membrane Nephropathy; Thin Basement Membrane Nephropathy associated with Focal Segmental Glomerulosclerosis	1, 9, 23, 24
$\alpha 4(\text{IV})$	COL4A4	2q36-q37	Autosomal Recessive Alport Syndrome; Autosomal Dominant Alport Syndrome; Benign Familial Hematuria and Thin Basement Membrane Nephropathy; Thin Basement Membrane Nephropathy associated with Focal Segmental Glomerulosclerosis	1, 9, 25, 26
$\alpha 5(\text{IV})$	COL4A5	Xq22-23	X-linked Alport Syndrome	27
$\alpha 6(\text{IV})$	COL4A6	Xq22-23	X-linked Alport Syndrome with Diffuse Leiomyomatosis (Contiguous Gene Syndrome)	28

Table 1. Type IV collagen chains, genes, chromosomal locations and related diseases.

## 2. Familial microscopic hematuria

In view of the Case we are presenting in the next section, it is worth discussing the issue of microscopic hematuria as the presenting symptom of patients with TBMN due to heterozygous mutations in the collagen IV genes. According to some older publications, these patients occasionally progress to proteinuria and chronic kidney disease (CKD) while a small percentage reach end-stage kidney disease (ESKD) on long follow-up<sup>5-8</sup>. In a paper we published in 2007, we presented our initial experience in investigating 116 patients of 13 Cypriot families, where 20 renal biopsies had the dual diagnosis of focal segmental glomerulosclerosis (FSGS) and TBMN. These families segregated microscopic hematuria, mild proteinuria and CKD of variable severity, including several patients with ESKD. Initially, we searched with no success, for mutations in genes responsible for primary autosomal dominant FSGS, such as *ACTN4* ( $\alpha$ -actinin 4) and *CD2AP* that were known and cloned at the time<sup>9</sup>. After some lengthy molecular investigations and new ideas, we ended up discovering that all patients who had FSGS on biopsy as well as many others in the same families, had heterozygous mutations in the *COL4A3* or *COL4A4* genes, which when

inherited in homozygosity or compound heterozygosity cause the classic autosomal form of Alport syndrome. In fact in one of our families, two patients developed classical Alport syndrome, as compound heterozygotes, after they inherited two mutations, one from each parent (G1334E/G871C) <sup>9</sup>.

In heterozygous patients, this dual diagnosis of TBMN and FSGS in the presence of CKD could not be easily explained. However this work established that under certain circumstances that are not so uncommon, several such patients do not remain with only familial benign microscopic hematuria that offers excellent renal prognosis but rather after the age of 40-50, some of them progress to CKD and ESKD. Long follow-up is the norm in our setting in Cyprus, where owing to the small population and the limited number of nephrology centers (six in total, including one pediatric nephrology clinic), the patients are attended by a small number of experts over several decades. Our current data of 180 patients reveal that nearly 50% of patients at all ages develop additional proteinuria with some degree of CKD, while 21% progress to ESKD (25% of all patients >50-yo) perhaps owing to the confounding role of modifier gene(s). These data cast doubt on the correctness of the belief that the diagnosis of TBMN, in patients who are heterozygous carriers of mutations in the *COL4A3*/*COL4A4* genes, is synonymous to "benign familial hematuria" with excellent renal prognosis.

### 3. Case presentation

In early 2008, a young Greek couple from Athens was referred to our laboratory with a clinical situation summarized as follows: The proband, individual III-2 in Figure 1A, was married and interested in having children. She and her husband asked for appropriate investigations aiming, if possible, to have an antenatal test, in order to avoid having children who might develop ESKD like her father. On her father's side there was no previous easily diagnosed history for a familial renal disease. Her father II-1, had presented in a London hospital in 1991, at age 46 years, with persistent microscopic hematuria, proteinuria 3.3g/day, hypertension on treatment with Enalapril, and with chronic renal failure, as evidenced by elevated serum creatinine and urea levels. The attending nephrologist estimated his creatinine clearance at 40-50 ml/min. A renal biopsy showed early glomerulo-sclerosis and uniform thinning of the GBM on EM that also included focal splitting. In the report, the diagnosis of possible hereditary Alport nephritis was discussed but it was not certain. He reached ESKD, four years later, at 50 and was transplanted at 52-yo, still with no deafness. The proband and her older sister had microscopic hematuria since childhood. In addition to microscopic hematuria, the proband's sister, III-1, had proteinuria. The proband's mother was healthy. The paternal uncle, subject II-3, had proteinuria of 2g/day, reduced GFR and elevated plasma creatinine at 2.8 mg/dl, with normal hearing which remained normal until the age of 54 when the last information is available. He also underwent a renal biopsy at age 45 years, which was compatible with focal and segmental glomerulosclerosis but no EM results were available. The proband's paternal grand-mother, subject I-2, was diagnosed with mild renal failure at age 76-yo, when she was evaluated and was refused to serve as a living kidney donor to her son. Her findings could not be properly evaluated and were attributed at the time to a familial condition or age related. The proband had been a competitive swimmer during adolescence and had studied physical education, something that initially prompted her nephrologist in Greece to attribute her microscopic hematuria to her extreme physical activities. Because of the above uncertain family history, the proband sought professional counselling and inquired about the prospects of molecular genetics helping her reach a correct diagnosis. At the same

time she and her husband were interested in undergoing a prenatal diagnosis in order to minimize the likelihood of bearing an affected child.

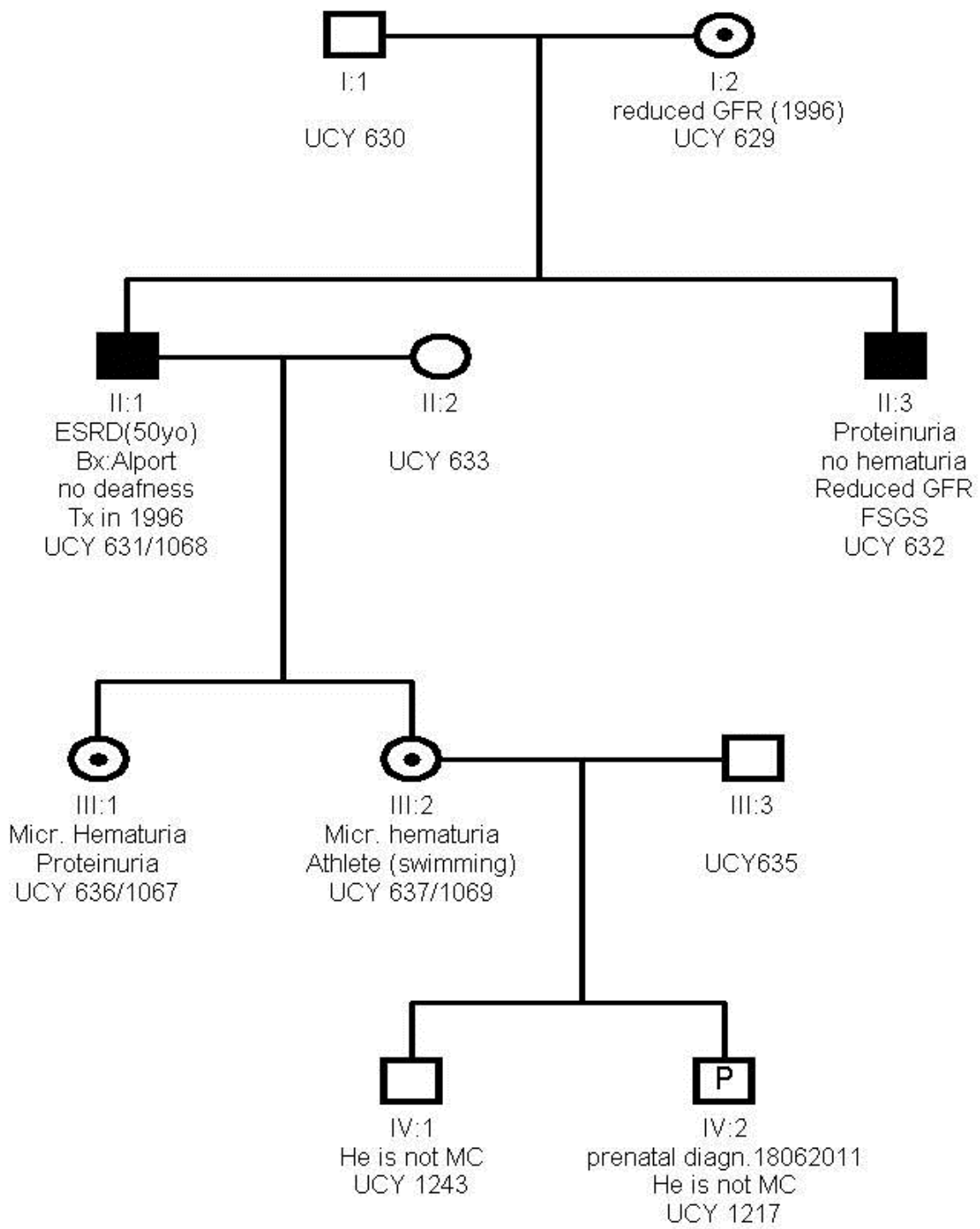

Fig. 1. A: Pedigree with relevant clinical information of the subjects under study. Note that the overall clinical scenario does not support a clear-cut X-linked or autosomal inheritance pattern.

#### 4. Differential diagnosis

Even though the X-linked Alport syndrome was a reasonable suspicion, the attending nephrologist in Greece was not in a position to support this diagnosis unequivocally. The biopsy histological picture and the EM findings of diffuse thinning of the GBM in particular, the absence of deafness as well as the very late age of onset of ESKD of the proband's father were not supportive of the classic adolescence onset X-linked Alport, as known in the early 1990's. This uncertainty was strengthened by the similar and even milder clinical course of his brother. The diagnosis was rather on the borderline between X-linked Alport syndrome and the heterozygous autosomal recessive Alport syndrome that actually presents with TBMN and microscopic hematuria, and then on long follow-up may develop FSGS with progression to CKD and ESKD. This second scenario for TBMN as the primary diagnosis was supported by our recent publication at the time, where we showed that in a large cohort of patients with *COL4A3/COL4A4* heterozygous mutations, a great percentage of patients can progress to CKD and/or ESKD with the need for hemodialysis or kidney transplantation, mostly around or after 50 years of age<sup>9</sup>. Actually, our current data show that 21% of such patients at all ages progress to ESKD, most of them after the age of 50.

The proband was interested in a prenatal diagnosis by molecular means, if possible. Therefore, considering that the molecular analysis of the implicated genes is costly and cumbersome some prerequisites had to be satisfied:

- a. Confirmation of the familial nature of the disease,
- b. a definite clinical diagnosis,
- c. the gene at fault had to be identified unequivocally,
- d. the germline mutation or the affected haplotype had to be identified, and
- e. a definite and unequivocal molecular test had to be developed.

In view of the uncertainty of the clinical diagnosis, a genetic counseling session took place between the nephrologist, the gynecologist and the parents in Greece, and the geneticist in Cyprus, which resulted in the decision to investigate further the family with molecular tools, with the purpose of satisfying the above necessary criteria before proceeding to pregnancy and a molecular prenatal test. At the time, the only credible symptom that segregated in the family in a dominant fashion was the microscopic hematuria, with three patients in two generations.

#### 5. Molecular investigations

In order to solve the diagnostic dilemma we were faced with and be able to perform a prenatal molecular diagnosis according to the couple's desire, we used the molecular approach. To this end, we first performed classic DNA linkage analysis for the Xq22-23-linked *COL4A5* locus and the chromosome 2q36-37-linked *COL4A3/COL4A4* locus. As shown in Figure 1B, 1C, we used four polymorphic microsatellite markers flanking the *COL4A3/COL4A4* locus and four markers flanking the X-linked locus of *COL4A5*. Under the assumption that the two affected brothers, subject II-1 and subject II-3, had inherited the same disease, we saw that they had inherited from their parents two different haplotypes around the *COL4A3/COL4A4* locus. The probability for this to happen is 25% but this serendipitous event assisted us in excluding this locus as being at fault. Please note that under either an autosomal dominant or autosomal recessive mode of inheritance, if the two brothers had inherited the same disease from their parents we expected them to



have at least one haplotype or two haplotypes, respectively, in common. In Figure 1C the analyses with the X-chromosome-linked markers show that both affected brothers, inherited the same haplotype from their mother which, as expected was passed on to the subject's two daughters. Even though this data was not strong enough based on the uncertain clinical diagnosis, we interpreted it as exclusion of the 2q locus and probable linkage to the X-linked locus.

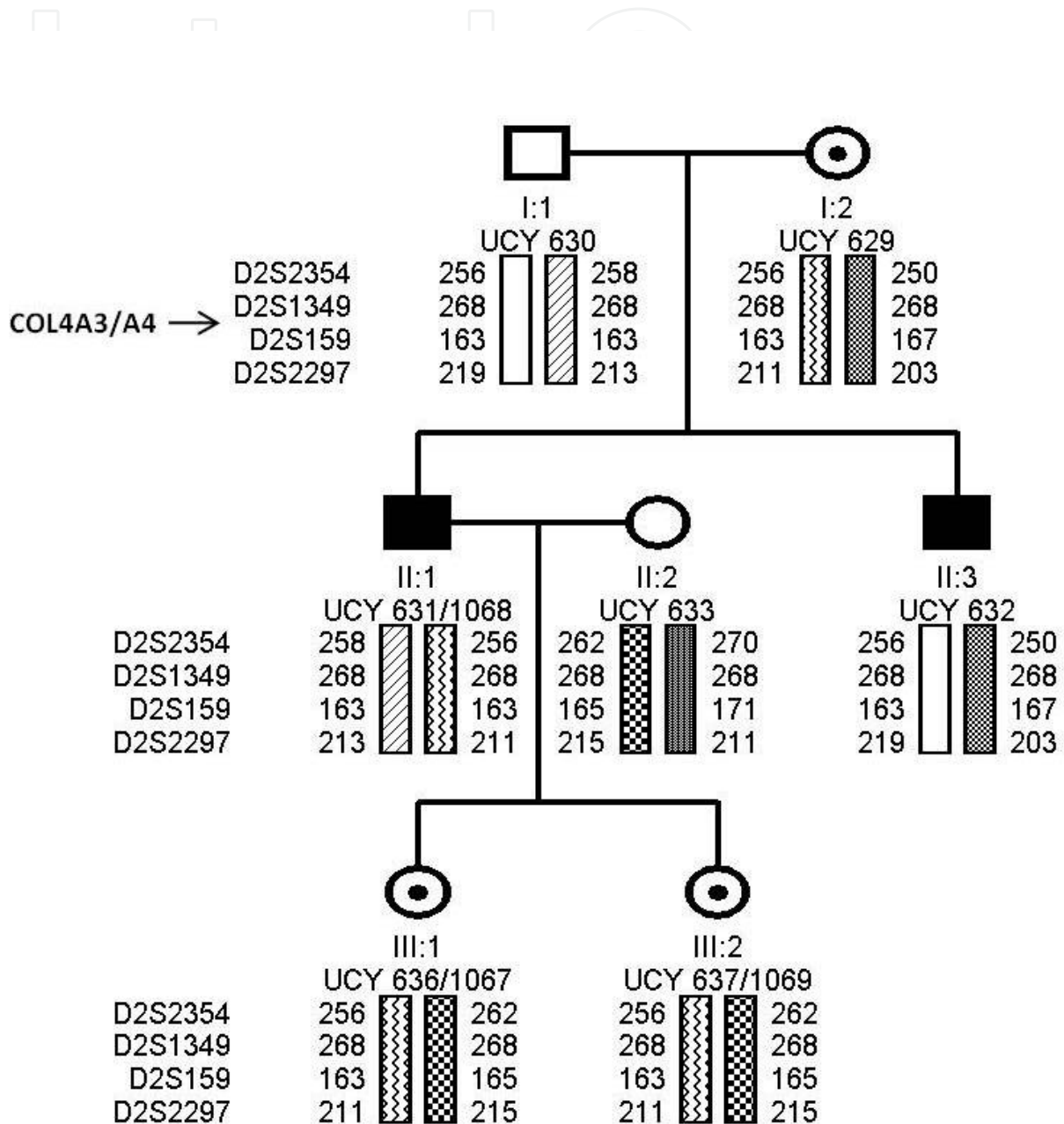

Fig. 1. B: Pedigree with DNA linkage analysis results at locus 2q36-37 (*COL4A3/COL4A4*). Note that the two brothers, II-1 and II-3, have inherited different haplotypes from their parents, hence proving no linkage to this locus.

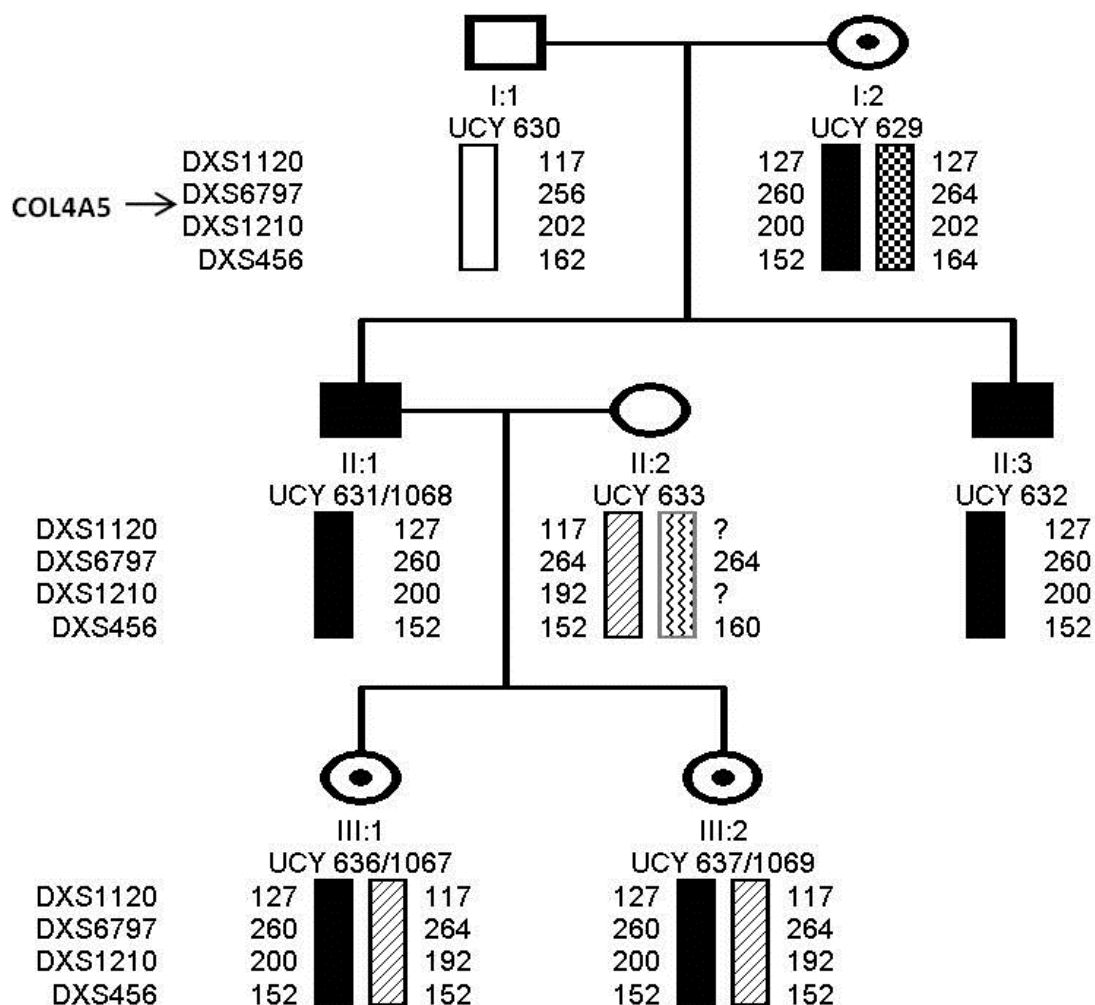

Fig. 1. C: Pedigree with DNA linkage analysis data for locus Xq22-23 (*COL4A5*). Note that these results are compatible with X-linked inheritance.

We then engaged into re-sequencing the *COL4A5* gene in patient II-1 by amplifying and sequencing all exons, including the splicing junctions and around 100 bp of flanking intronic regions. This sequencing revealed several polymorphic sites as well as a collagen mutation at position 624 that resulted in substitution of glycine by aspartic acid, G624D<sup>10</sup>. This mutation had been previously reported by three other groups and it was known to be associated with a milder Alport Syndrome phenotype, something that supported the mild presentation in our family<sup>11-13</sup>. Further molecular analysis for this mutation by polymerase chain reaction and restriction enzyme digestion showed that the two brothers II-1 and II-3 share this identical mutation which they have both inherited from their mother, individual I-2 in the pedigree (Figure 2). As expected, both daughters of subject II-1 inherited this mutation as they both inherited the X chromosome from their father. We now had a definite molecular test we could use for a prenatal diagnosis. We then communicated this information to the doctors and the couple and they went on with a pregnancy and a chorionic villous sampling at around ten weeks of gestation. Molecular testing was performed which showed that the foetus was a mutation-free male. The mother delivered a boy that on testing had no microscopic hematuria. No molecular analysis has been performed on the child yet. Approximately two years later the couple went on for a second pregnancy and a prenatal diagnosis showed again a healthy male. The pregnancy is still in progress.



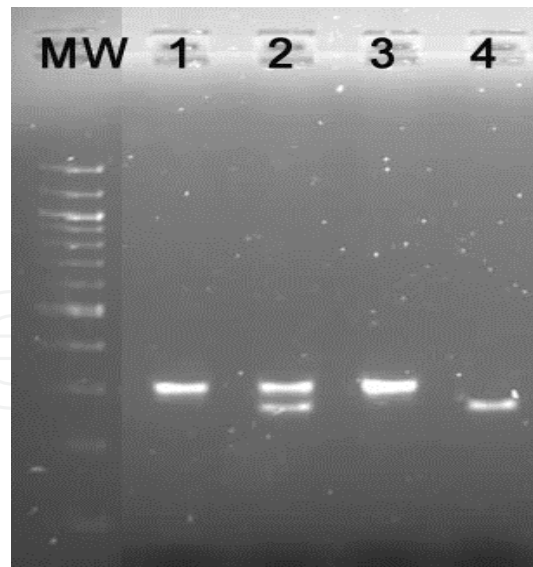

Fig. 2. DNA amplification by polymerase chain reaction, followed by restriction digest with enzyme EcoRV and electrophoresis on 3% agarose gel. The mutation G624D introduces a recognition site for EcoRV. Samples in lanes 1, 3 are from normal subjects, lane 2 is from a heterozygous female and lane 4 is from a hemizygous male. The region amplified encompasses exon 25 where the mutation G624D is located. It is a substitution of aminoacid glycine by aspartate because of a G>A transition at the second position of codon 624.

## 6. Ethical issues

The issue of prenatal diagnosis is always a difficult one and should be accompanied by proper professional genetic counselling. The classic Alport Syndrome is supposed to be one of the most severe glomerular diseases usually leading to ESKD before 30 years of age. It is true however, that in addition to this so called juvenile onset disease, there is the adult type where patients develop CKD and reach ESKD at older ages<sup>14,15</sup>. Based on current literature, this is certainly published and known by many experts; apparently though it has not become common knowledge to the average practising clinician. In addition to the family presented here we have identified five other families of Hellenic origin who share this same mutation, G624D, with a total of 13 male patients (unpublished results). Although the spectrum of clinical presentation is quite variable, the overall impression is that this mutation is a very mild one that leads to ESKD after the age of 40 years, even close to or after 50 years, in most cases. At the same time the EM studies do not show the classical thickening and lamellation of the usual X-linked Alport but extensive thinning of the GBM. Our findings agree with data presented in previous publications that identified this mutation in families from other populations<sup>10-13</sup>. However, the uncertainty and anxiety that accompany at-risk members belonging to families with conditions like this cannot always be dealt adequately clinically. This anxiety in the family and the uncertainty as to whether they were dealing with an X-linked or autosomal disease and the possibility of bringing to life an affected child, had led them to terminate an earlier pregnancy where the foetus was a male one. We only became aware of this event after the successful birth of their healthy first child. The aborted embryo might have been an affected or a healthy male under the scenario of X-linked inheritance; alternatively the embryo might have been a healthy male carrying no mutation or a heterozygous male, under the scenario of autosomal inheritance.

## 7. Discussion-concluding remarks

One cannot escape the conclusion that molecular genetics is an extremely powerful tool to use in present day clinical medicine. In another two families we had in Cyprus that segregated *COL4A5* mutation P628L, none of the clinicians that cared for the patients had initially thought of X-linked Alport Syndrome. The variable expression, the very late onset of ESKD and the milder atypical symptoms of male and female patients, even in the presence of older patients with ESKD, did not prompt us to suspect at the beginning X-linked Alport syndrome. A renal biopsy in one patient established the presence of TBMN, thereby suggesting different explanations. Interestingly, the pedigree structure could not give a clear-cut information for X-linked or autosomal inheritance, considering that some females had symptoms of the disease<sup>10</sup>. The symptoms in six female carriers included microscopic hematuria while two of them exhibited additional non-nephrotic proteinuria. Also, a renal biopsy of a 19-year-old female showed TBMN with FSGS. At this setting, perhaps a skin biopsy and immunostaining for collagen IV might be enlightening if the staining came out negative for the alpha 5 chain. No such biopsy was attempted.

Molecular testing for the *COL4A5* was attempted based on the inheritance of microscopic hematuria and exclusion of linkage to the chromosome 2 locus. It was only the molecular approach that established the diagnosis and enabled proper counselling and treatment to the concerned members.

Another issue that complicates matters is the genetic heterogeneity observed in a number of diseases, including inherited kidney conditions. Molecular defects in more than one gene complicate things as it doubles or triples the effort and the cost for a definite diagnosis. Newer tools and more robust methods for gene re-sequencing are clearly making things easier. Next generation sequencing and exome sequencing aimed at analyzing specifically the coding exonic sequences, can accelerate *COL4A3/COL4A4* screening in 1-2 weeks instead of the 8-12 months needed with the conventional methods in small laboratories<sup>16</sup>. However, still not every routine clinical diagnostic or University research laboratory is equipped with or has easy access to this newer generation of technology and machinery.

In conclusion, as regards the Alport Syndrome and mutations in one of the *COL4* genes, one should be aware of a) the rare, milder cases of X-linked *COL4A5*, Alport syndrome that presents with TBMN and delayed ESKD in the 50's and b) the late development of CKD and ESKD in patients with heterozygous *COL4A3/COL4A4* mutations and TBMN, also referred to by some as autosomal dominant Alport. The spectrum of these collagen IV nephropathies extends from vary mild cases with isolated microscopic hematuria for life on one end, and patients reaching ESKD during adolescence on the other end. Professionals involved in offering treatment and genetic counselling should be aware of these wide scenarios and they should offer the best possible advice making use of all available tools of our generation, including molecular approaches. Finally, it should be realized that the aetiology of familial microscopic hematuria is even more heterogeneous genetically. Recently, another inherited glomerulopathy, CFHR5 nephropathy, was described by Gale et al (2010)<sup>17</sup> and Athanasiou et al (2011)<sup>18</sup> that is mainly characterized by isolated C3 deposits in the mesangium and the sub-endothelial GBM area of the glomerulus. This nephropathy presents usually in childhood with persistent microscopic hematuria and 25% of such patients also show episodes of macroscopic hematuria that usually follow upper respiratory tract infections. Mostly affected are the male patients who can also progress to CKD and ESKD at ages over 30-40. Therefore, a useful algorithm is presented as a guideline for molecular testing of patients belonging to families segregating glomerular microscopic hematuria. A kidney or a

skin biopsy may be performed before or after the molecular analysis depending on the clinical status or disease progression of the patient, for histological evaluation<sup>19</sup> (Figure 3).

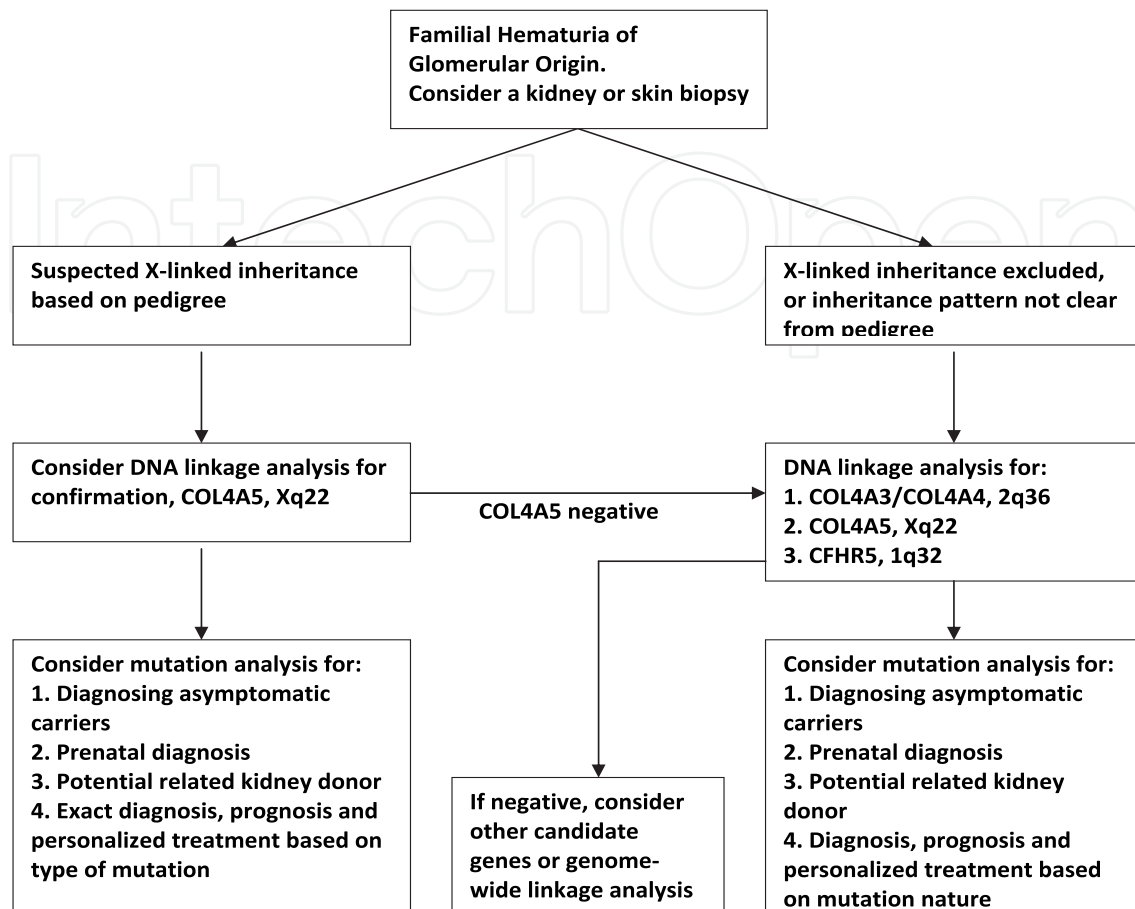

Fig. 3. Algorithm for molecular testing of patients belonging to families segregating microscopic hematuria of glomerular origin. A histological evaluation via a skin or renal biopsy accompanied by immunostaining before or after molecular investigations are performed, may assist in the diagnosis or provide useful clues for the direction of molecular analysis. When a causative germinal mutation is identified, it becomes feasible to offer genetic counseling as well as a reliable molecular diagnosis and prenatal testing with much easier and much less costly approaches (From ref. 19, with permission from Springer Publisher).

## 8. Acknowledgements

The authors express their gratitude to all patients and relatives who participated and made this study possible. The authors also thank Dr M. Petersen of Eurogenetica, Greece, for preparing and providing the foetal CVS sample. The work was partly supported from the Cyprus Research Promotion Foundation, through the grants ΠΕΝΕΚ/ΕΝΙΣΧ/0308/08 and ΝΕΥ ΙΝΦΡΑΣΤΡΟΤΥΡΕ/ΣΤΡΑΤΕΓΙΚ/0308/24 to CD and through the University of Cyprus articles 3/311 and 3/346 (CD).

## 9. References

- [1] Mochizuki T, Lemmink HH, Mariyama M, Antignac C, Gubler MC, Pirson Y, Verellen-Dumoulin C, Chan B, Schröder CH, Smeets HJ, et al: Identification of mutations in

- the  $\alpha 3(\text{IV})$  and  $\alpha 4(\text{IV})$  collagen genes in autosomal recessive Alport syndrome. *Nat Genet* 8:77-81, 1994.
- [2] Hudson BG, Tryggvason K, Sundaramoorthy M, Neilson EG: Alport's syndrome, Goodpasture's syndrome, and type IV collagen. *N Engl J Med* 348:2543-2556, 2003.
- [3] LeBleu VS, Macdonald B, Kalluri R: Structure and function of basement membranes. *Exp Biol Med (Maywood)* 232:1121-1129, 2007.
- [4] Khoshnoodi J, Pedchenko V, Hudson BG: Mammalian collagen IV. *Microsc Res Tech* 71:357-1370, 2008.
- [5] Kashtan CE: Familial hematurias: what we know and what we don't. *Pediatr Nephrol*, 20: 1027-1035, 2005.
- [6] Thorner PS: Alport syndrome and thin basement membrane nephropathy. *Nephron Clin Pract*, 106: c82-88, 2007.
- [7] Haas M: Alport syndrome and thin glomerular basement membrane nephropathy: a practical approach to diagnosis. *Arch Pathol Lab Med*, 133: 224-232, 2009.
- [8] Pierides A, Voskarides K, Athanasiou Y, Ioannou K, Damianou L, Arsali M, Zavros M, Pierides M, Vargemezis V, Patsias C, Zouvani I, Elia A, Kyriacou K, Deltas C: Clinico-pathological correlations in 127 patients in 11 large pedigrees, segregating one of three heterozygous mutations in the COL4A3/ COL4A4 genes associated with familial haematuria and significant late progression to proteinuria and chronic kidney disease from focal segmental glomerulosclerosis. *Nephrol Dial Transplant*, 24: 2721-2729, 2009.
- [9] Voskarides K, Damianou L, Neocleous V, Zouvani I, Christodoulidou S, Hadjiconstantinou V, Ioannou K, Athanasiou Y, Patsias C, Alexopoulos E, Pierides A, Kyriacou K, Deltas C: COL4A3/COL4A4 mutations producing focal segmental glomerulosclerosis and renal failure in thin basement membrane nephropathy. *J Am Soc Nephrol*, 18: 3004-3016, 2007.
- [10] Demosthenous P, Voskarides K, Stylianou K, Hadjigavriel M, Arsali M, Patsias C, Georgaki E, Ziropiannis P, Stavrou C, Daphnis E, Pierides A, Deltas C: X-linked Alport syndrome in Hellenic families: Phenotypic heterogeneity and mutations near interruptions of the collagen domain in COL4A5. *Clin Genet*, 2011 (doi: 10.1111/j.1399-0004.2011.01647).
- [11] Martin P, Heiskari N, Zhou J, Leinonen A, Tumelius T, Hertz JM, Barker D, Gregory M, Atkin C, Styrkarsdottir U, Neumann H, Springate J, Shows T, Pettersson E, Tryggvason K: High mutation detection rate in the COL4A5 collagen gene in suspected Alport syndrome using PCR and direct DNA sequencing. *J Am Soc Nephrol*, 9: 2291-2301, 1998.
- [12] Barker DF, Denison JC, Atkin CL, Gregory MC: Efficient detection of Alport syndrome COL4A5 mutations with multiplex genomic PCR-SSCP. *Am J Med Genet*, 98: 148-160, 2001.
- [13] Slajpah M, Gorinsek B, Berginc G, Vizjak A, Ferluga D, Hvala A, Meglic A, Jaksic I, Furlan P, Gregoric A, Kaplan-Pavlovic S, Ravnik-Glavac M, Glavac D: Sixteen novel mutations identified in COL4A3, COL4A4, and COL4A5 genes in Slovenian families with Alport syndrome and benign familial hematuria. *Kidney Int*, 71: 1287-1295, 2007.
- [14] Feingold J, Bois E, Chompert A, Broyer M, Gubler MC, Grunfeld JP: Genetic heterogeneity of Alport syndrome. *Kidney Int*, 27: 672-677, 1985.
- [15] Gubler MC, Antignac C, Deschenes G, Knebelmann B, Hors-Cayla MC, Grunfeld JP, Broyer M, Habib R: Genetic, clinical, and morphologic heterogeneity in Alport's syndrome. *Adv Nephrol Necker Hosp*, 22: 15-35, 1993.



- [16] Artuso R, Fallerini C, Dosa L, Scionti F, Clementi M, Garosi G, Massella L, Carmela Epistolato M, Mancini R, Mari F, Longo I, Ariani F, Renieri R, Bruttini M: Advances in Alport syndrome diagnosis using next-generation sequencing. *Eur J Hum Genet* advanced online publication, September 7, 2011; doi:10.1038/ejhg.2011.164.
- [17] Gale DP, Goicoechea de Jorge E, Cook T, Martinez-Barricarte R, Hadjisavvas A, McLean AG, Pusey CD, Pierides A, Kyriacou K, Athanasiou Y, Voskarides K, Deltas C, Palmer A, Frémeaux-Bacchi V, de Cordoba SR, Maxwell PH, Pickering MC: Complement Factor H-Related protein 5 (CFHR5) Nephropathy: an endemic cause of renal disease in Cyprus. *The Lancet* 376(9743):794-801, 2010.
- [18] Athanasiou Y, Voskarides K, Gale DP, Damianou L, Patsias C, Zavros M, Maxwell PH, Cook HT, Demosthenous P, Hadjisavvas A, Kyriacou K, Zouvani I, Pierides A, Deltas C: Familial C3 glomerulopathy associated with CFHR5 mutations: Clinical characteristics of 91 patients in 16 pedigrees. *Clin J Am Soc Nephrol* 6(6):1436-1446, 2011.
- [19] Deltas C, Pierides A, Voskarides K: The role of molecular genetics in diagnosing familial hematuria(s). *Pediatr Nephrol*. DOI: 10.1007/s00467-011-1935-5, 2011.
- [20] Gould DB, Phalan FC, Breedveld GJ, van Mil SE, Smith RS, Schimenti JC, Aguglia U, van der Knapp MS, Heutink P, John SWM: Mutations in Col4a1 cause perinatal cerebral hemorrhage and porencephaly. *Science* 308: 1167-1171, 2005.
- [21] Gould DB, Phalan FC, van Mil SE, Sundberg JP, Vahedi K, Massin P, Bousser MG, Heutink P, Miner JH, Tournier-Lasserre E, John SWM: Role of COL4A1 in small-vessel disease and hemorrhagic stroke. *New Eng J Med* 354: 1489-1496, 2006.
- [22] Plaisier E, Gribouval O, Alamowitch S, Mougénot B, Prost C, Verpont MC, Marro B, Desmettre T, Cohen SY, Rouillet E, Dracon M, Fardeau M, Van Aghtmael T, Kerjaschki D, Antignac C, Ronco P: COL4A1 mutations and hereditary angiopathy, nephropathy, aneurysms, and muscle cramps. *New Eng J Med* 357: 2687-2695, 2007.
- [23] van der Loop FTL, Heidet L, Timmer EDJ, van den Bosch BJC, Leinonen A, Antiganc C, Jefferson JA, Maxwell AP, Monnens LAH, Schroder CH, Smeets HJM: Autosomal dominant Alport syndrome caused by a COL4A3 splice site mutation. *Kidney Int* 58:1870-1875, 2000.
- [24] Badenas C, Praga M, Tazon B, Heidet L, Arrondel C, Armengol A, Andres A, Morales E, Camacho JA, Lens X, Davila S, Mila M, Antignac C, Darnell A, Torra R: Mutations in the COL4A4 and COL4A3 genes cause familial benign hematuria. *J Am Soc Nephrol* 13: 1248-1254, 2002.
- [25] Ciccarese M, Casu D, Wong FK, Faedda R, Arvidsson S, Tonolo G, Luthman H, Satta A. Identification of a new mutation in the  $\alpha 4(\text{IV})$  collagen gene in a family with autosomal dominant Alport syndrome and hypercholesterolaemia. *Nephrol Dial Transpl* 16:2008-2012, 2001.
- [26] Lemmink HH, Nillesen WN, Mochizuki T, Schroder CH, Brunner HG, van Oost BA, Monnens LA, Smeets HJ: Benign familial hematuria due to mutation of the type IV collagen  $\alpha 4$  gene. *J Clin Invest* 98: 1114-1118, 1996.
- [27] Barker DF, Hostikka SL, Zhou J, Chow LT, Oliphant AR, Gerken SC, Gregory MC, Skolnick MH, Atkin CL: Identification of mutations in the COL4A5 collagen gene in Alport syndrome. *Science* 248:1224-1227, 1990.
- [28] Zhou J, Mochizuki T, Smeets H, Antignac C, Laurila P, de Paepe A, Tryggvason K, Reenders ST: Deletion of the paired  $\alpha 5(\text{IV})$  and  $\alpha 6(\text{IV})$  collagen genes in inherited smooth muscle tumors. *Science* 261:1167-1169, 1993.

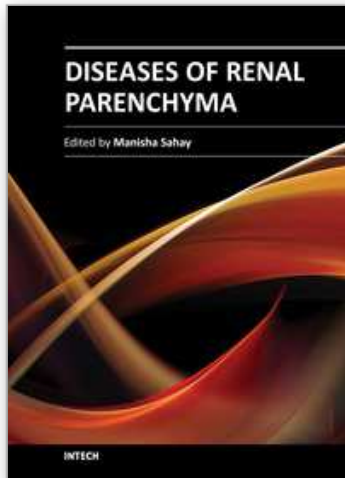

## **Diseases of Renal Parenchyma**

Edited by Prof. Manisha Sahay

ISBN 978-953-51-0245-8

Hard cover, 304 pages

**Publisher** InTech

**Published online** 16, March, 2012

**Published in print edition** March, 2012

Clinical nephrology is an evolving speciality in which the amount of information is growing daily. This book gives quick access to some important clinical conditions encountered in nephrology including the diseases of glomeruli, tubules and interstitium. It presents the latest information on pathophysiology, diagnosis and management of important diseases of renal parenchyma. The information is presented in a very user friendly and accessible manner while the treatment algorithms enable the reader to quickly access expert advice on arriving at the most appropriate treatment regimen. The book discusses the renal involvement in various systemic diseases including diabetes and autoimmune diseases. Diabetic nephropathy is fast becoming the commonest cause of end stage renal disease all over the globe and is discussed in this book. The editors believe that this book will be a valuable addition to the reader's library.

### **How to reference**

In order to correctly reference this scholarly work, feel free to copy and paste the following:

Constantinos Deltas, Konstantinos Voskarides, Panagiota Demosthenous, Louiza Papazachariou, Panos Ziropiannis and Alkis Pierides (2012). The Power of Molecular Genetics in Establishing the Diagnosis and Offering Prenatal Testing: The Case for Alport Syndrome, Diseases of Renal Parenchyma, Prof. Manisha Sahay (Ed.), ISBN: 978-953-51-0245-8, InTech, Available from: <http://www.intechopen.com/books/diseases-of-renal-parenchyma/the-power-of-molecular-genetics-in-establishing-the-diagnosis-and-offering-prenatal-testing-the-case>

**INTECH**  
open science | open minds

### **InTech Europe**

University Campus STeP Ri  
Slavka Krautzeka 83/A  
51000 Rijeka, Croatia  
Phone: +385 (51) 770 447  
Fax: +385 (51) 686 166  
[www.intechopen.com](http://www.intechopen.com)

### **InTech China**

Unit 405, Office Block, Hotel Equatorial Shanghai  
No.65, Yan An Road (West), Shanghai, 200040, China  
中国上海市延安西路65号上海国际贵都大饭店办公楼405单元  
Phone: +86-21-62489820  
Fax: +86-21-62489821



© 2012 The Author(s). Licensee IntechOpen. This is an open access article distributed under the terms of the [Creative Commons Attribution 3.0 License](#), which permits unrestricted use, distribution, and reproduction in any medium, provided the original work is properly cited.

IntechOpen

IntechOpen