

We are IntechOpen, the world's leading publisher of Open Access books Built by scientists, for scientists

4,800

Open access books available

122,000

International authors and editors

135M

Downloads

Our authors are among the

154

Countries delivered to

TOP 1%

most cited scientists

12.2%

Contributors from top 500 universities



WEB OF SCIENCE™

Selection of our books indexed in the Book Citation Index
in Web of Science™ Core Collection (BKCI)

Interested in publishing with us?
Contact book.department@intechopen.com

Numbers displayed above are based on latest data collected.

For more information visit www.intechopen.com



Hardware Design of Embedded Systems for Security Applications

Camel Tanougast, Abbas Dandache,
Mohamed Salah Azzaz and Said Sadoudi
*University Lorraine of Metz
France*

1. Introduction

Embedded systems are electronic computer systems designed for dedicated operating functions, often while respecting several constraints like real-time computing, power consumption, size and cost, etc. Embedded systems control many devices in common use today such as *smartphones*, *GPS*, *codec GSM*, *decoders*, *MP3*, *MPEG62*, *MPEG4*, *PDA*s, *RFID*s, *smart cards* and *networked sensors* etc. Generally, they are controlled by one or more main processing cores that are typically either *Microcontrollers*, *Digital Signal Processors (DSPs)* or *Field Programmable Gate Arrays (FPGAs)*. These systems are embedded as part of a complete electronic system, often including software, hardware, and communication and sensor parts. By contrast, a general-purpose computer - such as a *Personal Computer (PC)* - is designed to be flexible and to meet a wide range of end-user needs. The key characteristic of an embedded system is that it is dedicated to the handling of a particular task. They may require very powerful processors and extensive communications. Ideally, these embedded systems are completely self-contained and will typically run off a battery source for many years before the batteries need to be changed or charged. Since such systems are embedded and dedicated to specific tasks, design engineers search to optimise them by reducing their size (miniaturisation made possible by advanced *IC* design in order to couple full communication subsystems to sophisticated sensors) and cost in terms of energy consumption, memory and logic resources, while increasing their reliability and performance. Consequently, embedded systems are especially suited for use in transportation, medical applications, safety and security. Indeed, in dealing with security, embedded systems can be self-sufficient and should be able to deal with communication systems. Considering these specific conditions, in the fields of information and communication technology, embedded systems designers are faced with many challenges in terms of both the trade-off between cost/performance/power and architecture design. This is especially true for embedded systems designs, which often operate in non-secure environments, while at the same time being constrained by such factors as computational capacity, memory size and - in particular - power consumption. One challenge is in the design of hardware architecture able to meet the appropriate level of security and - consequently - the best trade-off between hardware resources and the best throughput rates for real-time embedded applications.

A digital implementation of chaotic generators presents certain advantages and provides accuracy and a significant hope for integration in embedded applications, especially for data

encryption and secure communications between embedded systems. Unlike analogue implementations, which exhibit various practical difficulties in ensuring information recovery and dealing with the problem of chaotic synchronisation (since the component values vary with age and temperature, etc.), a digital implementation avoids the parameter mismatch between transmitter and receiver. Indeed, a programmable hardware fabric like a *FPGA (Field Programmable Logic Array)* is taking an increasingly important place in the design of embedded digital systems. This is due to the excellent trade-off between computational power and the flexibility of processing which it provides.

This chapter is organised as follows: In Section 2, the related embedded design approaches suitable for embedded secure application (encryption) are briefly described. Section 3 explores the architecture of a hardware implementation for helping system designers who are faced with many challenges with regards to the trade-off between *cost/performance/power/security* and architecture design. Section 4 gives an overview, namely a characterisation of three dimensional (3-D) continuous chaotic systems used for embedded encryption applications. In this section, the background of the digital design based on a numerical resolution method of the 3D chaotic systems is given. Section 5 presents and discusses in detail the various steps involved in the design of a chaotic system as well as the design of its programmable hardware technology, and it illustrates this with the *Genesisio's* chaotic system designed in a *FPGA*. Finally, Section 6 summarises and concludes the chapter.

2. Overview of the hardware design of embedded systems

The electronic computing architecture of embedded systems is often composed of embedded blocks as parts of a complete device, often including hardware, an interface and mechanical parts. Usually, these systems are designed digitally in order to be flexible and to meet a wide range of application constraints. Therefore, embedded systems contain processing cores (*CPUs*) associated with several peripherals (integrated peripherals like *Analogue-to-Digital Converters (ADCs)*, *Digital-to-Analogue Converters (DACs)*, analogue signal conditioning blocks allowing them to operate as a *System-on-Chip*) that typically consist of *Microcontrollers*, *Digital Signal Processors (DSPs)* or else *hardware specific cores* tailored for dedicated tasks. These embedded architectures allow a good trade-off between performance, cost and application constraints (real-time processing, power consumption, etc.). Usually, these embedded systems are defined as *Systems on Chip (SoC)* and presented in a hand-format. Figure 1 provides an overview of one embedded *System on Chip* (a *Bluetooth System on Chip*).

However, the significant requirements and different constraints for an embedded application and the characteristics of the embedded system dedicated to handling a particular task must be taken into account. Their requirements often lead to the design of a specific embedded system for application in just one field. In this context, a methodological approach based on embedded design flow and available technologies must be considered by taking into account the advantages and main drawbacks for meeting the application constraints of the embedded application under consideration. Since embedded systems are dedicated to certain specific tasks, design engineers can optimise them in order to reduce their size and their cost, as well as increasing their reliability and performance by considering the following hardware design approach.

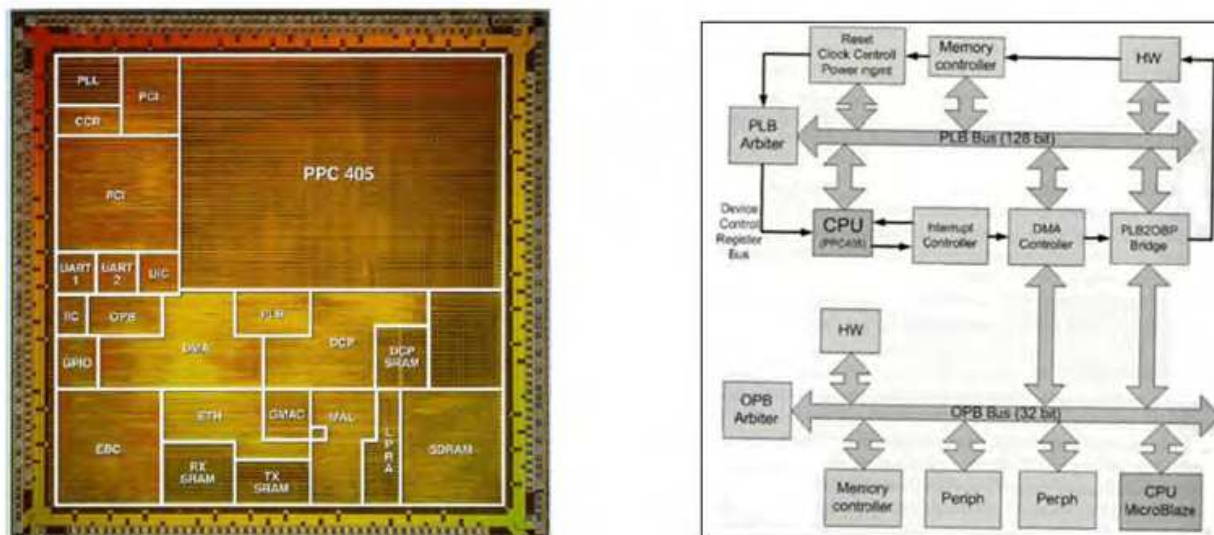

Fig. 1. Bluetooth embedded System on Chip.

The embedded system design specification stage includes successive analysis steps which will impact on the performance of the system - depending on the choice of technology used - which must comply with the application constraints. Thus, we adopt a definition of a system's specifications (the required functions, environment, input/output system, etc.) which focuses on the selection of the available technology. In this context - and depending, for example, of the system timing requirements or other timing constraints, limitations of size or the logic area and memory requirements - the development of new embedded systems products is not trivial for electronics designers. Therefore, depending on the choice of the technology used, the application requirements may not be respected.

Among the technology available for the design of embedded systems, we find:

- The processor or microcontroller (corresponding to one core processor associated with a peripheral), often defined as a software solution.
- The specific integrated circuit and the programmable circuit, such as a CPLD (*Complex Programmable Logic Device*) or now a FPGA, often defined as a hardware solution.

All of these present specific advantages and drawbacks. Thus, an *Application-Specific Integrated Circuit (ASIC)* - which is an integrated circuit customised for particular tasks - is not intended for general-purpose use. Similarly, an *Application-Specific Standard Product (ASSP)* - which is a custom product for a specific application designed for use by more than one customer - is not adapted. Indeed, the flexibility of the embedded system is required, where changes continue even after the embedded system was designed. Moreover, although the ASIC presents the best performance with low power consumption, the main drawbacks of an *Integrated Circuit (IC)* are its very high cost (which is always increasing) and lengthened development time, which is unsuitable for the design of an embedded system where evolution occurs quickly.

Software solutions based on a micro-programmed system, such as a CPU, a *Microcontroller* or a *DSP*, present the very best flexibility since they are only based on the change of instructions in the memory. However, their main drawback is that their computation is weakly intensive, especially for some embedded applications where the process requires a

long computation time. Therefore, for most applications the computation time will be prohibitive if a software solution is adopted. This effect is directly related to the nature of *Von Neumann's* architecture of a *CPU* which cannot operate in a parallel fashion.

FPGAs have been taking an increasingly significant place in the design of embedded digital systems thanks to their excellent trade-off between computing power and the flexibility of processing that they provides [Tanougast et al., 2003]. This is particularly true for embedded system design, which can be used for quality evaluation or protocol communication in a network of data diffusion [Compton & Hauck, 2002]. Thus, *FPGAs* are increasingly used in conventional high performance computing applications where computations are performed on the *FPGA* instead of on a microprocessor. Indeed, the logic implementation based on *FPGAs* offers performance improvements an order of magnitude over microprocessors. For example, take the implementation of the *Advanced Encryption Standard (AES)* encryption on a *Xilinx Virtex5 FPGA* [Xilinx, 2008], which runs at 100MHz – this is 10 times faster than a highly optimised *AES* encryption running on the latest *CPU* [Burr, 2003; Liu, 2005]. Other benefits are in terms of the power used, where a *FPGA* implementation of applications is expected to consume less power than a microprocessor. Low-power usage is due to a lower clock rate and the absence of wasted cycles for the fetch/decode instruction in *FPGAs*. In this context, the use of *FPGA* technology makes it possible to optimise the hardware resources required while allowing for real-time computing. Moreover, an alternate approach based on a *FPGA* is to use soft processor cores that are implemented within the *FPGA* logic. *MicroBlaze* and *Nios II* are the most popular softcore examples provided by the main *FPGA* companies (*Altera* and *Xilinx*) [Xilinx1, 2008; Altera, 2011]. Figure 2 presents comparisons in terms of flexibility versus performance between the available technologies dedicated for embedded system design.

Usually, designs implemented on *FPGAs* require on average 18 times as much logic area, 7 times as much dynamic power and are 3 times slower than the corresponding *ASIC* implementations. Although *FPGAs* have been slower, less energy efficient and have generally achieved less functionality than their *ASIC* counterparts, their main advantages lie in their ability to reprogram in order to fix bugs, their shorter design time and the lower non-recurring engineering costs suitable for a faster embedded system design. Therefore, one solution for embedded designers is in reconfigurable systems based on *FPGAs* that can be reprogrammed to accommodate changing standards and protocols in the design process. Moreover, *FPGA* technology allows the designer to control all the phases of the design from the prototype.

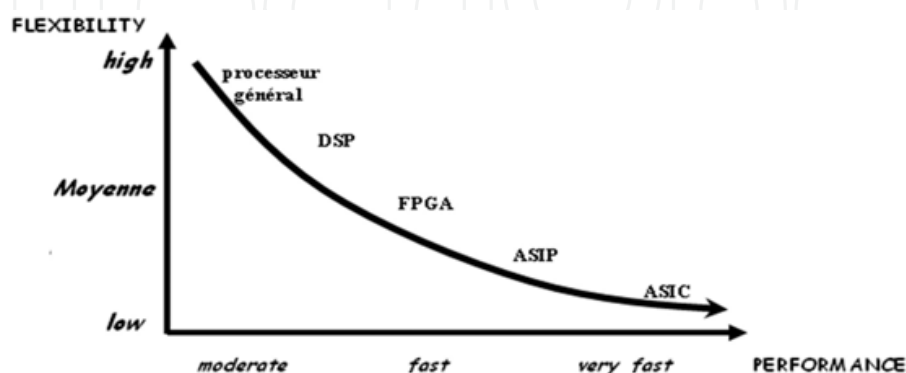

Fig. 2. Flexibility versus performance of the main technologies suitable for an embedded digital system.

A recent trend has been to take a coarse-grained architectural approach by combining the logic blocks and interconnections of traditional *FPGAs* with embedded microprocessors and related peripherals. The goal is to form a complete "System on a Programmable Chip" suitable for a large performing embedded system. In this context, advances in *Very-large-Scale Integration (VLSI)* technology have been employed to the manufacturing of reconfigurable logic for *FPGA* chips; and helped with their rapid growth in logic capacity, performance and popularity. In summary, a *FPGA*-based architecture is suitable for efficient computing of embedded applications with high data rate to compute. It is an excellent alternative to performing fast processing in order to reduce the total processing time, while maintaining a good level of flexibility in allowing any modifications in the run time required for current embedded systems.

3. Architecture exploration

The objective of an architecture exploration is to find an efficient matching between an algorithm and the architecture. The aim is to realise an optimal implementation that satisfies the various constraints (real-time, logic area, etc.). Therefore, digital hardware techniques can be used to implement efficiency in embedded applications like chaotic generators for embedded encryption by using digital devices such as *microcontrollers*, *DSPs*, *ASICs*, *processors* and *FPGA* technologies. The choice of implementation in a digital system is driven by many criteria and is heavily dependent on the application area. Table 1 gives the main contrasting features of current digital technologies for the design of embedded systems.

Features	Processors / DSP / Microcontroller (Software)	FPGA (Hardware programmable)	ASICs (Hardware)
Silicon area	Fixed	Variable	Fixed and low
Speed	Moderate	Fast	Very fast
Consumption	Moderate	High	Weak
Cost	Low	Moderate	High
Prototyping	Yes	Yes	No

Table 1. Features of the main technologies available for the design of embedded systems.

As mentioned previously, the designer can realise any embedded system (based on either the logic design and/or software design thanks to the embedded *softcore* processor) by utilising programmable logic devices in the form of *FPGAs* and *CPLDs* [Brown & Rose, 1996]. In the design context, the objective of *Algorithm/Architecture Adequation* (architecture exploration based on *A³* methodology [Sorel, 1994]) is to realise an optimal implementation which satisfies the constraints (real-time, logic area, etc.). In this Section, we illustrate an analysis of the costs and benefits of the use of reconfigurable technology such as *FPGAs*.

In practice, the actual embedded system is composed inside the chip of a high coupled processor with a *Programmable Array (FPGA, CPLD, etc)*. Indeed, such a hardware structure allows the combination of the advantages of these two technologies inside the same circuit. Consequently, coupling can reduce the main drawbacks of these technologies when they are used individually. Figure 3 illustrated one such embedded programmable hardware core which is usually associated with peripheral modules.

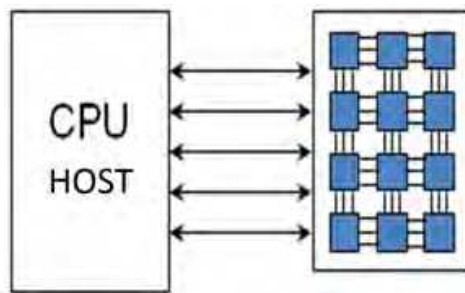

Fig. 3. High coupled processor - *FPGA* - on a chip core of a current embedded programmable hardware system.

With regard to the task of implementing an algorithm on a similar embedded programmable hardware system, we can distinguish two approaches [Tanougast et al., 2003]. The most common is what we call *the application development approach* and the other is what we call *the system design approach*. In the first case, we have to fit an algorithm with an optional time constraint in an existing system made from a host *CPU* connected to a reconfigurable logic array. In this case, the goal of an optimal implementation is to minimise one or more of the following criteria: processing time, memory bandwidth and power consumption. In the second case, we have to implement an algorithm with a required time constraint on a system which is still in the design exploration phase. The design parameter is the size of the logic array, which is used to implement the data path part of the algorithm. Here, an optimal implementation is that which leads to the minimal logic area of the reconfigurable array, memory resources and input/output port number. Figure 4 depicts an overview of the hardware design approaches of embedded systems.

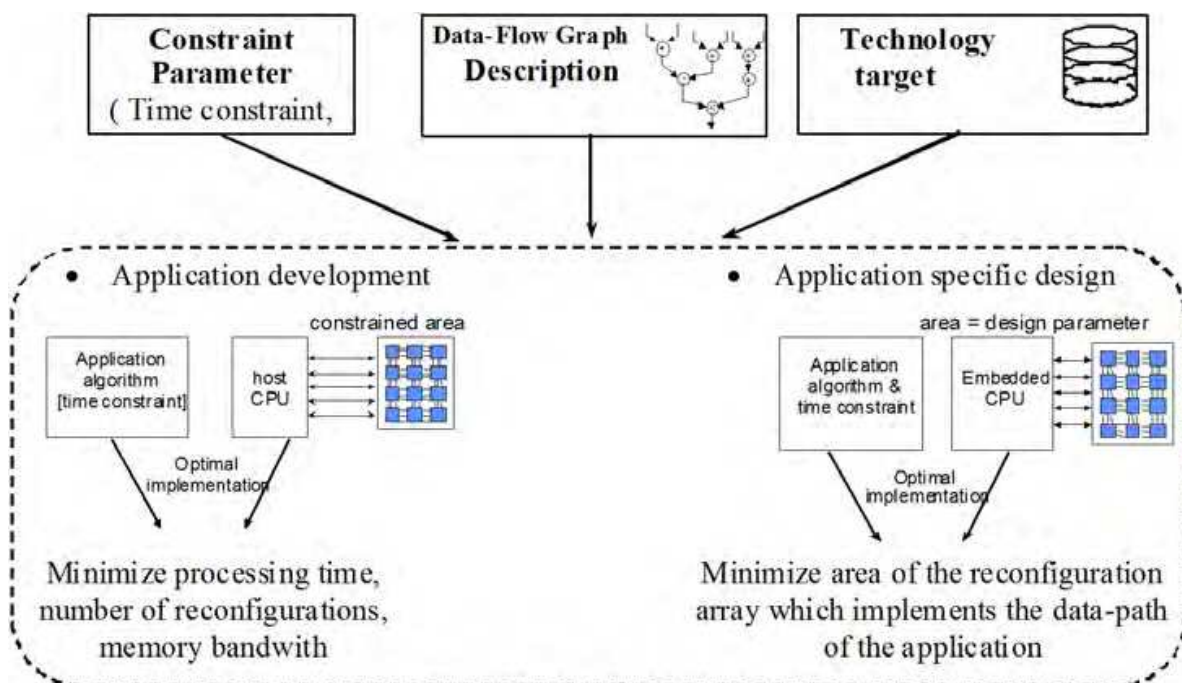

Fig. 4. The two approaches used to implement an algorithm on reconfigurable hardware.

Embedded systems exhibit several advantages through the use of *FPGAs*. The most obvious is the possibility for frequently updating the digital hardware functions. However, we can

also use the dynamic resources allocation feature in order to instantiate each operator for the strict required time. This permits the enhancement of silicon efficiency by reducing the reconfigurable array's area. Consequently, the goal of the embedded system designers in architectural design flow is to minimise the *FPGA* resources needed for the implementation of a time constrained algorithm. So, the challenge is twofold. Firstly, to find a trade-off between flexibility and algorithm implementation efficiency through the programmable logic-array coupled with a *CPU* host (processor, *DSP*, etc.). Secondly, to obtain an optimal architecture synthesis allowing the best hardware implementation trade-off required for embedded applications.

In the rest of this chapter, we describe the main steps in the hardware design of embedded systems for security applications. We will consider an encryption process based on key chaotic generators and a mechanism for mixing the key with plaintext (*encryption/decryption* process).

4. Embedded digital chaotic cryptosystem

Chaos-based encryption suggests a new and efficient way of dealing with the problem of fast and highly secure data encryption. To implement the chaotic behaviour generators and the chaotic attractors associated with certain practical applications, many methods based on analogue circuits are used, such as switched capacitors or analogue *Complementary Metal Oxide Semiconductor* (*CMOS*) technology [Matsumoto, 1987; Giannakopoulos et al., 2007; Ozoguz et al., 2005; Cha & Lee, 2005]. However, these methods exhibit some practical difficulties since the component values vary with age and temperature, etc. [Aseeri et al., 2002; Sobhy et al., 1999]. To overcome this problem, a digital implementation of chaotic generators can be used, since the problem of parameter mismatch does not exist and it provides accuracy and a significant possibility of integration in the embedded system, allowing many possibilities for embedded applications. The originality of this cipher scheme is that it allows for low cost data encryption for embedded systems while still providing a good trade-off between performance and hardware resources. The experimental results have demonstrated the feasibility and efficiency of this secure solution for *FPGA* technology. In the rest of this chapter, thorough experimental tests are presented with detailed analysis, demonstrating the high security and fast encryption speed suitable for embedded cryptosystems where resource optimisation is required in the field of embedded applications.

4.1 Chaotic generators-based encryption

In recent years, a variety of encryption schemes have been proposed for real-time secure data transmission over the Internet and through wireless networks by embedded systems. Among them, chaos-based algorithms have shown some attractive properties in terms of security, complexity, speed, computing power and computational overheads, etc. More precisely, although chaotic systems are characterised by specific attractors, their generated chaotic signals are non-periodic, uncorrelated and appear random in the time domain. These properties increase the complexity of a cryptanalysis attack in terms of the visualisation and identification of the signals used for key generation through a key space analysis. Hence, embedded cryptosystems for secure communications based on chaos theory have been proposed and developed while showing that these embedded systems can be controlled

[Lorenz, 1963; Yang, 2004]. Indeed, the synchronisation between two identical chaotic embedded systems corresponding to the data encryption transmission module and the decryption reception module has been reported [Carroll & Pecora, 1990]. Consequently, it was concluded that a key generator based on chaos theory could be useful with regard to secure communication systems because chaos is extremely sensitive to initial conditions and parameters [Azzaz et al., 2011].

Usually, the embedded cryptosystems are based on the design of a real-time secure symmetric encryption scheme. According to the basic principles of cryptology, a cryptosystem should be sensitive to the key - i.e., the cipher-text should have a close correlation with the key. To accomplish this requirement, we can use an efficient (ideally, genuinely random) key generation mechanism and then mix the key thoroughly into the plain-text through the encryption process. One data encryption scheme is based on embedded chaotic key generators. Therefore, the complete *encryption/decryption* scheme consists of two operational steps, as shown for example by the Figure 5 for real time image encryption scheme.

- Step 1.** *Chaotic key generation and selection.* A key is generated from the previous key and one sequence of word-length bits as the key is selected in a chaotic manner.
- Step 2.** *Cipher operations are performed.* For example, the basic cipher that is performed is the XOR or NXOR operation.

According to the key binary sequence generated, each section of data is then operated on with the selected key. For instance, in an image encryption stream (see figure 5), each data image pixel is then *XORed* with the selected key. The decipher procedure is similar to that of the encipher process illustrated above, but with a reverse operation sequence to that described in *Steps 1* and *2* above. Since both the decipher and encipher procedures have similar structures, they have essentially the same algorithmic complexity and duration of operation.

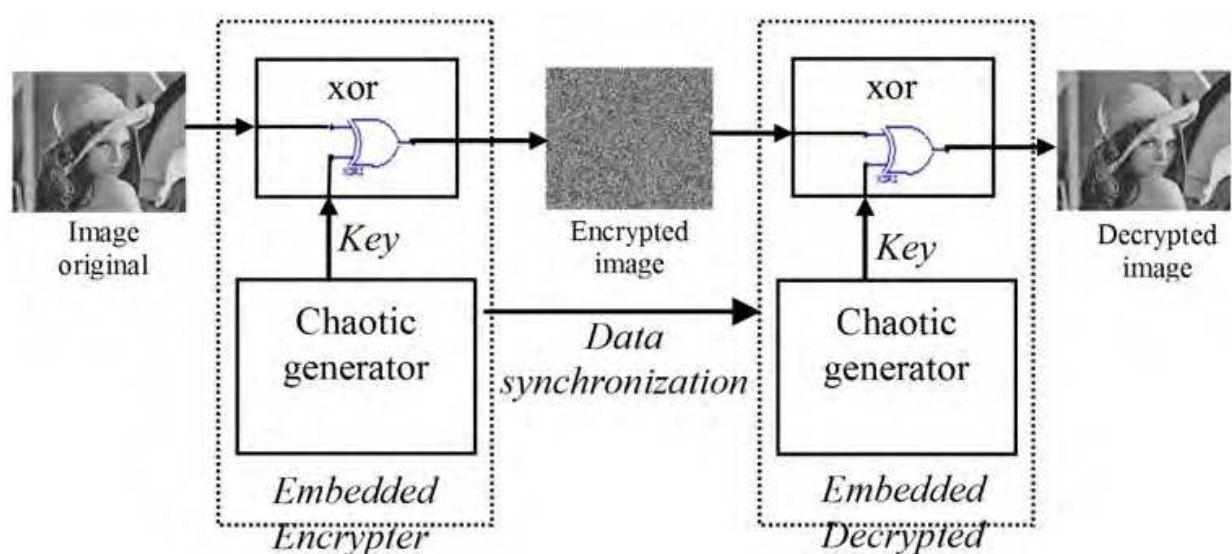

Fig. 5. Example of an embedded encryption scheme: real time image encryption based a chaotic key generator.

4.2 Tri-dimensional chaotic systems: chaos behavioural modelling and software simulation

Among chaotic systems, we find the continuous chaotic systems characterised by a system of differential equation systems. Most of the continuous chaotic systems can be expressed by an equivalent form of a three-dimensional system. Among them, we cite the tri-dimensional (3D) chaotic system, exemplified by such as *Lorenz's*, *Chen's*, *Lü's*, *Colpitts*, *Chua's*, *Rössler's*, *Linz* and/or *Sprott's* systems, etc. [Kvarda, 2002; Chen et al., 2007; Lü & Chen, 2002; Kennedy, 1994; Indrusiak, 2005; Genesio, 1993; Genesio & Tesi, 1992; Park, 2007]. These 3D systems provide chaotic behaviours which depend on the initial conditions and parameter values characterising them. In particular, the *Lorenz* system is a famous example of a chaotic system [Lorenz, 1963]. It is represented by the following simplified nonlinear equation system [Cuomo, 1993] which can be understood in terms of chaotic behaviour, depending of the parameter values:

$$\begin{cases} \frac{dx}{dt} = \sigma(y-x) & (1a) \\ \frac{dy}{dt} = -xz + rx-y & (1b) \\ \frac{dz}{dt} = xy-bz & (1c) \end{cases}$$

The solution of this nonlinear equation system depends mainly on the initial conditions specified by the initial values of $x = x_0$, $y = y_0$ and $z = z_0$. For instance, a numerical solution to this system with Lorenz's parameters' values ($\sigma = 10$, $r = 28$ and $b = 8/3$) and initial conditions ($x_0 = 0$, $y_0 = 5$, $z_0 = 25$) gives the corresponding chaotic signals x , y and z , and the two different attractors of the chaotic system are shown in Figure 6 (obtained under the *MatLab* simulation environment tool [Mathworks, 2006]).

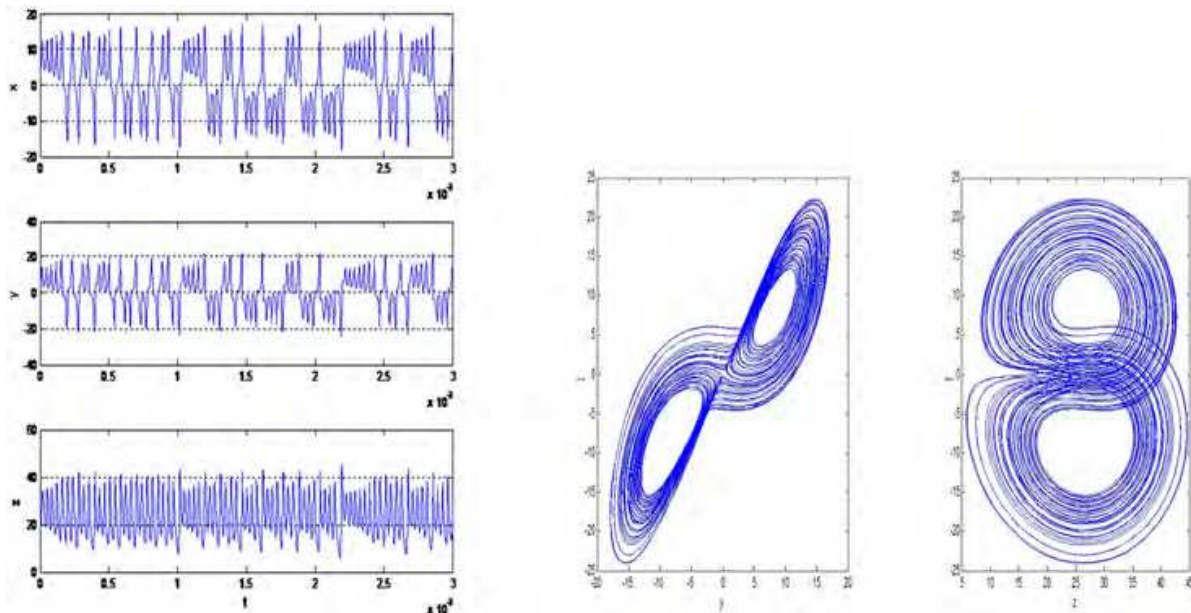

Fig. 6. *MatLab* simulation results of *Lorenz's* chaotic signals and attractors in a phase plane: $(x-y)$ and $(y-z)$.

4.3 Digital implementation based on the numerical resolution of 3D chaotic systems

One efficient and optimised solution for implementing a 3D chaotic embedded system is to design a specific logic hardware architecture tailored for a digital numerical resolution method. Among these, we can cite both *Euler's* and *Runge-Kutta's* numerical resolution methods [Yang et al., 2005; Cartwright & Piro, 1992]. Unlike the *Euler* method - a numerical procedure for solving the simplest approximation by the first-order differential equations with initial conditions - the *Runge-Kutta* method allows for the most accurate solutions. Indeed, in numerical analysis, the *Runge-Kutta* method characterises an important family of implicit and explicit iterative methods for the approximation of solutions for *Ordinary Differential Equations (ODEs)* [Cartwright & Piro, 1992]. These numerical methods are based on the principle of iteration, which is to say that the first estimate of the solution is used to calculate a second estimate, more precisely, and so on. One member of the family of *Runge-Kutta* methods used is the fourth-order *Runge-Kutta* equation method, often referred to as the "classical *Runge-Kutta* method" or simply "*RK-4*". Hereafter, we focus here on the *RK-4* method.

Let us consider the following first-order nonlinear differential equation system modelling the behaviour of a 3D chaotic system:

$$\begin{cases} \frac{dx}{dt} = F(x, y, z) \\ \frac{dy}{dt} = G(x, y, z) \\ \frac{dz}{dt} = Q(x, y, z) \end{cases} \quad (2)$$

where $x(t_0) = x_0$, $y(t_0) = y_0$ et $z(t_0) = z_0$ and F , G , Q are nonlinear functions. The *RK-4* method uses several intermediate points to calculate the next value, starting from the initial value and the step length h in t , as specified by the following equations:

$$x_{n+1} = x_n + \frac{h}{6}(k_0 + 2k_1 + 2k_2 + k_3) \quad (3)$$

$$y_{n+1} = y_n + \frac{h}{6}(m_0 + 2m_1 + 2m_2 + m_3) \quad (4)$$

$$z_{n+1} = z_n + \frac{h}{6}(n_0 + 2n_1 + 2n_2 + n_3) \quad (5)$$

where at the initial t_0 instant:

$$k_0 = F(t_n, x_n) \quad (6)$$

$$m_0 = G(t_n, y_n) \quad (7)$$

$$n_0 = Q(t_n, z_n) \quad (8)$$

at $t_0 + h/2$ instant:

$$k_1 = F\left(t_n + \frac{h}{2}, x_n + \frac{h}{2}k_0\right) \quad (9)$$

$$m_1 = G\left(t_n + \frac{h}{2}, y_n + \frac{h}{2}m_0\right) \quad (10)$$

$$n_1 = Q\left(t_n + \frac{h}{2}, z_n + \frac{h}{2}n_0\right) \quad (11)$$

$$k_2 = F\left(t_n + \frac{h}{2}, x_n + \frac{h}{2}k_1\right) \quad (12)$$

$$m_2 = G\left(t_n + \frac{h}{2}, y_n + \frac{h}{2}m_1\right) \quad (13)$$

$$n_2 = Q\left(t_n + \frac{h}{2}, z_n + \frac{h}{2}n_1\right) \quad (14)$$

and at $t_0 + h$ instant:

$$k_3 = F(t_n + h, x_n + hk_2) \quad (15)$$

$$m_3 = G(t_n + h, y_n + hm_2) \quad (16)$$

$$n_3 = Q(t_n + h, z_n + hn_2) \quad (17)$$

5. Digital programmable hardware implementation

Since the introduction of *FPGAs*, the process of digital systems design has changed radically [Hauck, 1998]. This technology allows the appearance of hardware that is as flexible as the programming paradigm in the realisation of real-time applications. In the case of the implementation of a digital chaotic system, most approaches based on *FPGA* are designed using a non-optimal description embedded architecture by using automatic code generation tools as in [Aseeri et al., 2002; Sobhy et al., 1999]. However, the “high level” aspect of these methods keeps the user far away from the realities of the physical implementation (the low level corresponding to the *Register Transfer Level (RTL)*) required for the performance of a design analysis allowing the best hardware implementation. Consequently, in terms of performance and density of resources used, the result remains out of the designer’s reach, which cannot be accepted by embedded electronic designers, where optimisation and efficient implementation form a primary purpose.

In the rest of this section, we present a case study of the specific design implementation of one chaotic embedded cryptosystem based on the *RTL* architecture described as structural *VHDL (VHSIC - Very High Speed Integrated Circuits - Hardware Description Language)* suitable for a high data encryption rate.

5.1 Case study: *Genesis-Tesi's system*

The *Genesis-Tesi* system, proposed by *Genesis* and *Tesi* [Sadoudi et al., 2010], is one of the paradigms of chaos since it captures many of the features of chaotic systems. The *Genesis-Tesi* chaotic oscillator is one of the most famous and well-studied continuous nonlinear and non-autonomous chaotic systems, exhibiting various dynamic behaviours, including chaos and bifurcations [Genesis, 1993; Genesis & Tesi, 1992]. The chaotic system includes a simple square part and three simple ODEs that depend on three positive parameters [Park, 2007]. The nonlinear dynamic equations of the system are as follows:

$$\begin{cases} \frac{dx}{dt} = y & \text{(a)} \\ \frac{dy}{dt} = z & \text{(b)} \\ \frac{dz}{dt} = -az - by + x^2 - cx & \text{(c)} \end{cases} \quad (18)$$

where x , y and z are the state variables, and a , b and c are the positive real constants satisfying $ab < c$. The chaotic regime of the equation (18) is obtained by the following bifurcation parameter values $a = 1.2$, $b = 2.92$ and $c = 6$ with the initial conditions $x_0 = 0.2$, $y_0 = 0.2$ and $z_0 = 0$ [Sadoudi et al., 2010]. The *MatLab* [Mathworks, 2006] simulation results of this chaotic system are given by Figures 7 and 8 where the chaotic signals x , y and z and the three-dimensional (3D) chaotic attractors (x - y and x - z chaotic attractors) are presented, respectively. These results will be useful as references for the implementation of the hardware results detailed in Section 5.8.

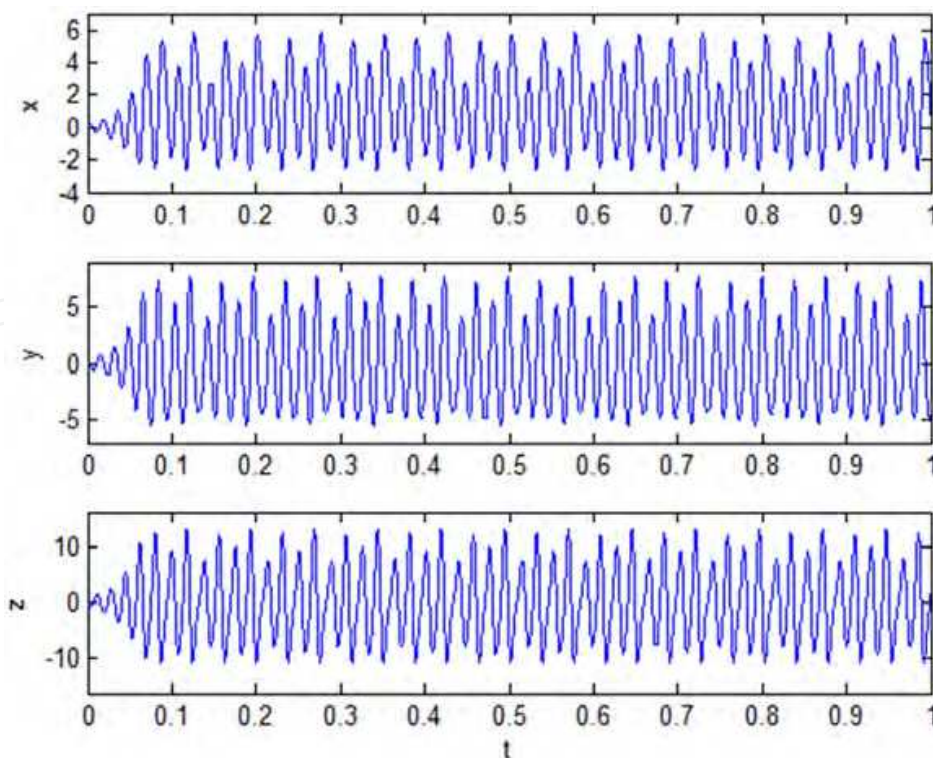

Fig. 7. *MatLab* simulation results of the x , y and z chaotic signals.

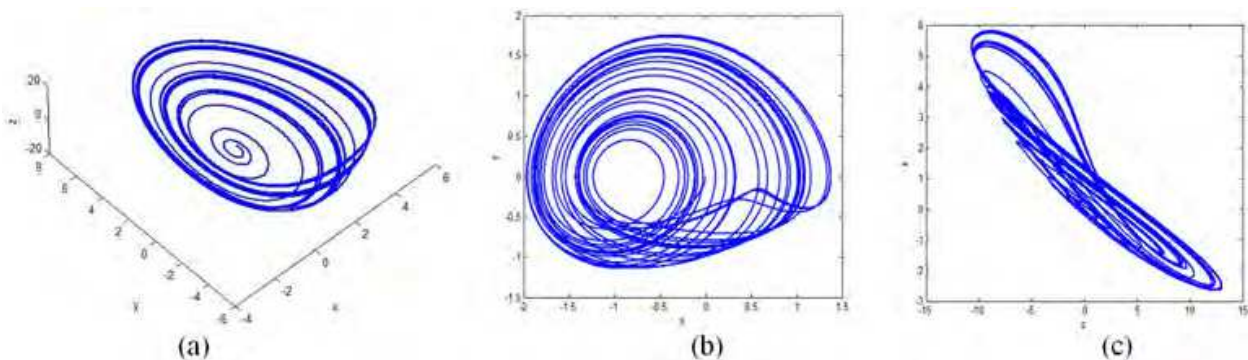

Fig. 8. *MatLab* simulation results: (a) the 3D chaotic attractor; (b) the x - y chaotic attractor; (c) the x - z chaotic attractor.

5.2 FPGA technology

FPGA is an integrated circuit designed to be configured by the customer or the designer. Embedded systems design can have several advantages for our approach based on *FPGAs* [Tanougast et al., 2003; Compton & Hauck, 2002; Hauck, 1998]. The most obvious is the possibility of frequently updating the digital hardware's functions. The challenge is then to find trade-offs between flexibility and algorithm implementation efficiency through the programmable logic-array. They are used in various applications requiring digital electronic functions (signal processing, telecommunications, embedded systems, etc.). They are generally slower, more expensive by unit and consume more energy than their equivalents in *ASIC* (*IC* dedicated to an application) technology. However, as mentioned in the previous section, the reconfigurable embedded systems based on *FPGA* are interesting for embedded chaotic generators in the way that they ensure better computing performance in comparison with a *CPU* core and in the way that they allow the flexibility necessary for multi-standard encryption applications. Indeed, with such embedded systems, it is easy to update a suitable cipher encryption at a lower cost as compared with silicon *IP* (*Intellectual Property*) corresponding to one specific *ASIC* encryption bloc. More precisely, suppose that we have to implement a cryptosystem design requiring P equivalent gates and taking an area S_{area} of silicon in the case of a full custom *ASIC* design. We will need about $100 \times S_{area}$ if we decide to use a *FPGA*. However, the significant advantage of the *FPGA* is, of course, its high flexibility and the speed of the associated design flow. This is probably the main reason for including a *FPGA* array on an embedded *System on Chip*. In summary, *FPGAs* present several advantages:

- The time to market is shorter because they are standard components.
- They have a shorter development and design period because they reuse basic functions and their circuit configuration is made on site.
- They present a lower cost for small quantities (less than 10,000 units). With technological evolution, this quantity tends to increase. Indeed, the cost of a chip is proportional to its logic area, which decreases with fine engraving, while the initial costs of producing an *ASIC* (design, testing and etching masks) are rapidly increasing.

Physically, a *FPGA* is a programmable logic device which can be programmed once or several times, depending on the technology used (*SRAM*, *EPROM*, and *ANTIFUSE*). Generally, one *FPGA* contains an array of *Programmable or Configurable Logic Blocks* (often

called "Logic Blocks" and depending on a vendor denoted by *CLB* - *Configurable Logic Block* - by the *Xilinx* company, or by *LAB* - *Logic Array Block* - by the *Altera* company) and a hierarchy of reconfigurable interconnects through "Router Matrix Blocks" that allow the *Logic Blocks* to be inter-wired in different configurations (routing channels). Locally around the periphery of the device, the input and output cells (*I/O pads*) allow the logical connection interfaces between the design inside the *FPGA* and off-chip modules external to the device. These *I/O* components can be configured as an input, output or bidirectional interface pin. The resulting structure is vendor-dependant (*Altera*, *Actel*, *Xilinx* companies, etc.). According to the arrangement of the *Logic Blocks* and their interconnections on the device, *FPGAs* can be classified according to several categories, such as a *symmetrical array*, a *hierarchy-based array* and a *row-based array*, etc. Figure 9 describes an overview of a *symmetrical array* based the *FPGA* currently used (*Xilinx's Virtex FPGA* technology) [Xilinx2, 2007].

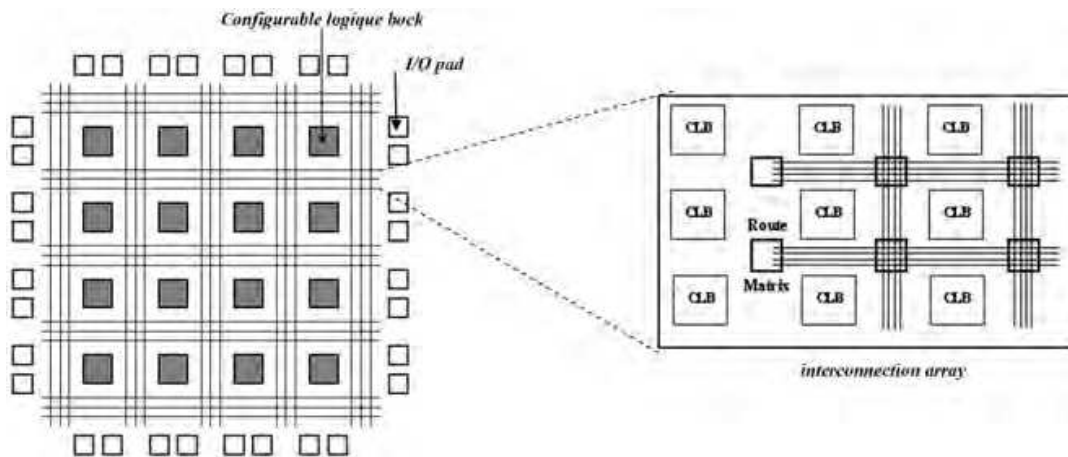

Fig. 9. Overview of the inner architecture of a FPGA.

Currently, *Logic Blocks* (*CLB* or *LAB*) consist of *logical cells* (denoted *LEs*, *Slices*, etc.) which are typically cells based on an *n-inputs function generator* (usually denoted as *Look-Up Tables (LUTs)*) associated with registers through local select interconnects. An *LUT* is generally made up of 4 to 6 inputs - according to the manufacturer or the *FPGA* family - and one output, which is used to implement logic equations by the combination of input values. One *LUT* acts as a truth table and then specifies its output based on its inputs and the contents of the table. The advantage of such a logic structure is in replacing a tree of logic operators with an easier consultation operation. Consequently, the speed gain increases and can be significant because one read logic value is often faster than one logic operation. Figure 10 illustrates the principle of a four-input *LUT*.

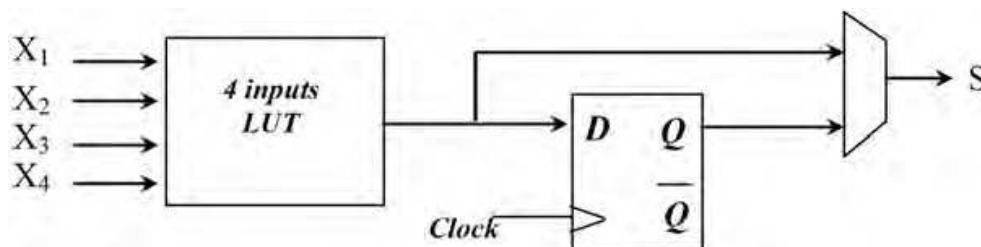

Fig. 10. Generic overview of a 4-input Look-Up Table.

Thanks to programmable *LUTs*, *Logic blocks* can be configured to perform complex combinational functions, or merely simple logic gates such as *AND* and *XOR*. In most *FPGAs*, the logic blocks also include memory elements, which may be simple flip-flops or more complete blocks of memory. Therefore, depending of the *FPGA* technology and family, the logical cells can also include other logic functions. For instance, Figure 11 describes one *Logic Block* involving *Virtex* technology [Xilinx3, 2000] which consists of two 3-input *LUTs*, a *Full Adder (FA)* and a *D-type flip-flop*. In this example, depending of the mode of the cell, there are several possible configurations. In normal mode, the two 3-input *LUTs* are combined into a 4-input *LUT* through one multiplexer operator [Xilinx3, 2000] (*Mux* operator block in Figure 11) while in the arithmetic mode, their outputs are fed to the *FA* block. The selection of the mode is programmed thanks to one multiplexer (the middle *Mux*). Similarly, the output of the *LUT* can be either synchronous or asynchronous, depending on the programming of one of the multiplexers at the output cell. In practice, entire or parts of the *FA* are placed as functions into the *LUTs* in order to save on the costs of the logic area.

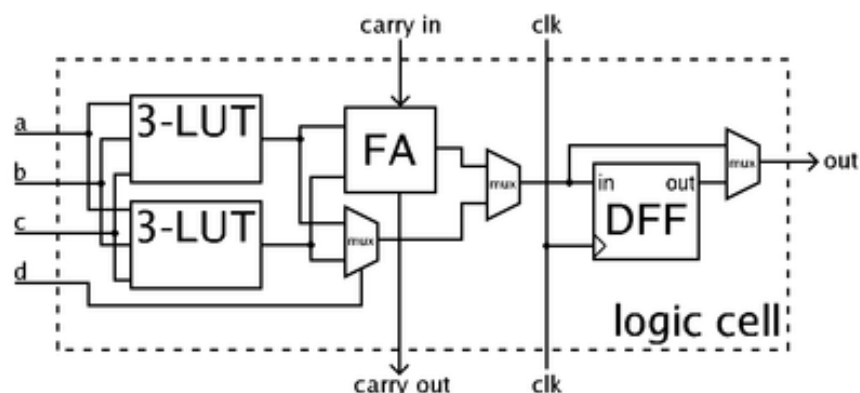

Fig. 11. Structure one *Programmable Logic Component* based on two 3-input *LUTs* involving *Virtex FPGA* technology [Xilinx3, 2000].

In the current trend, modern *FPGAs* contain embedded components such as memory blocks, multipliers and even processors cores. These *FPGA* families expand upon the above capabilities to include higher level functionality fixed into the silicon. Having these common functions embedded into the silicon reduces the area required and gives those functions increased speed when compared with building them from primitives. Thus, the *Virtex II* technology includes two *IBM 405 PowerPC* processor cores in the *Xilinx Virtex II Pro device*, as described by Figure 12, which gives an overview of this *FPGA* chip [Xilinx2, 2007]. By including one or more hardcore processor cores on the *FPGA* chip, this allows the preservation of the configurable logic resources.

Similarly, some *Logic Blocks* can include complex arithmetic and logic units, such as embedded processors, depending on the type or family of the *FPGA* technology used (commonly referred to as the size granularity of the *Logic Cells*). Examples of these include *multipliers*, generic *DSP (digital signal processing)* blocks, high speed *I/O* logics and *embedded memories*. For example, a number of complex operations are performed using a specific arithmetic *FPGA* block called a *DSP-Block*. This type of arithmetic structure is frequently implemented onto a *Virtex FPGA* chip in order to implement digital signal processing operations. One *DSP-block* contains a multiplier of 18×25 bits and one accumulator to store

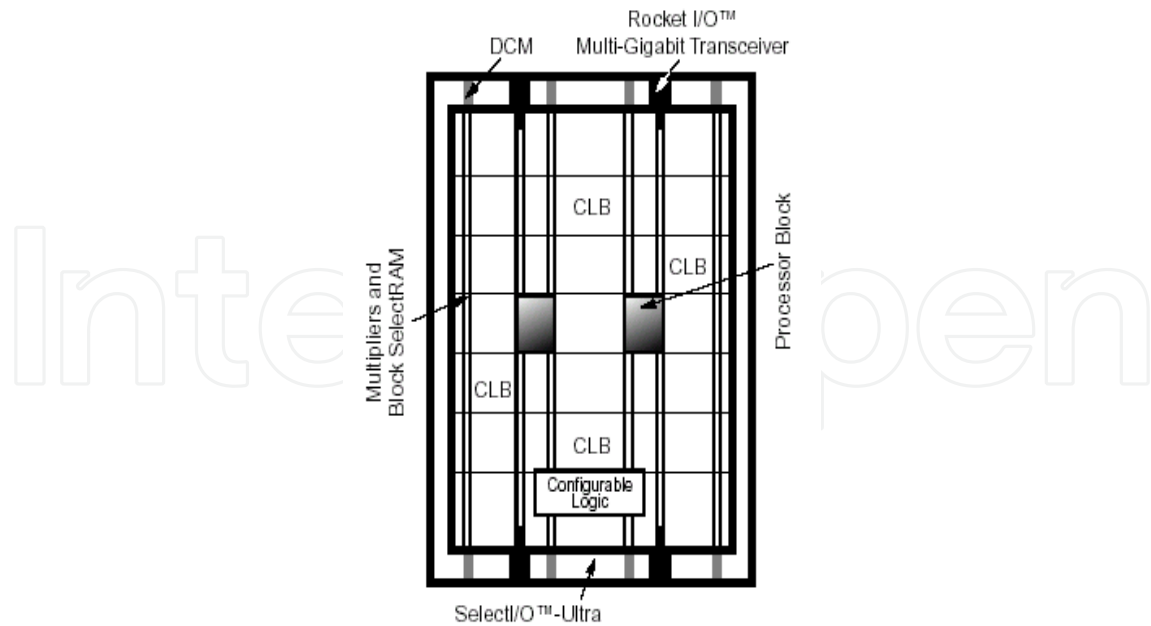

Fig. 12. Overview of the *Xilinx Virtex II FPGA* chip [Xilinx2, 2007].

the operational results [Xilinx2, 2007; Xilinx3, 2000; Xilinx, 2008]. Figure 13 presents one *DSP*-block.

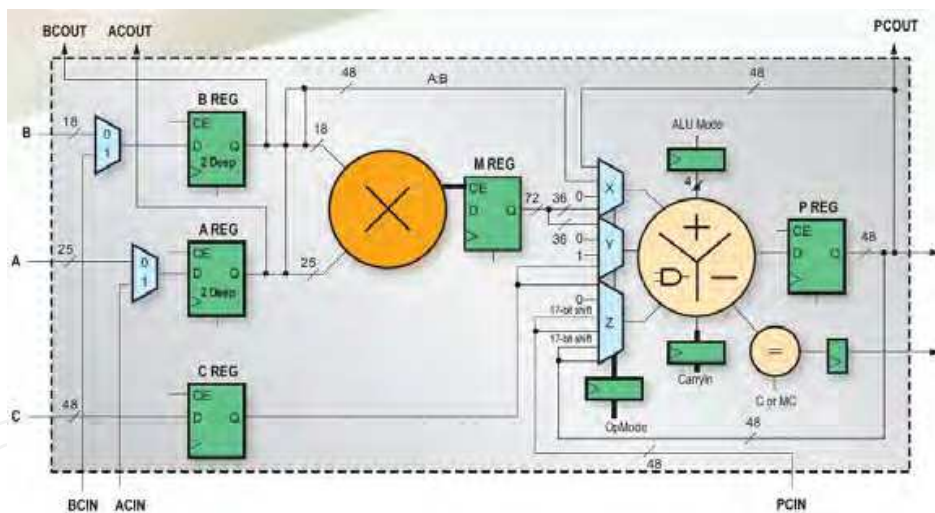

Fig. 13. Overview of the data-path of one *DSP*-Block using the *Xilinx Virtex II* and *V* technologies [Xilinx2, 2007; Xilinx3, 2000; Xilinx, 2008].

In fact, modern *FPGAs* are large enough and contain enough memory to be configured with either a generic or specific processor in order to execute software code. These configured processor units are called *softcore* processors as opposed to *hardcore* processors, which are buried in the silicon of the *FPGA*. As an example of such a *softcore* processor, we can cite the *MicroBlaze* or *Nios* processors of the *Xilinx* and *Altera* companies, respectively [Xilinx1, 2008; Altera, 2011]. Of course, this trend does not preclude the use of *softcore* processors in addition to the already embedded *hardcore* processors. However, it tends to increase the integration complexity of systems in the *FPGA* silicon chip.

To define the behaviour and configuration of the *FPGA*, the user provides a *Hardware Description Language (HDL)* or a schematic design. Generally, the designers of digital embedded applications use a *HDL* - such as *Verilog* or *VHDL* (*VHSIC - Very High Speed Integrated Circuits - Hardware Description Language*) - to describe the functionality of *FPGAs*. Indeed, in the field of electronic design, *HDL* acts as specification and modelling languages for the description and design of electronic logic circuits. Therefore, designers can describe the operations, design and organisation of their digital circuit, and test it to verify their operation by means of simulation. In a typical design flow, a *FPGA* application developer will describe and simulate the design at multiple stages throughout the design process. The *FPGA* design flow comprises of several steps, namely design entry, design synthesis, design implementation (mapping place and route) and device programming. Figure 14 gives an overview of the *FPGA* design flow carried out by specific automation tools.

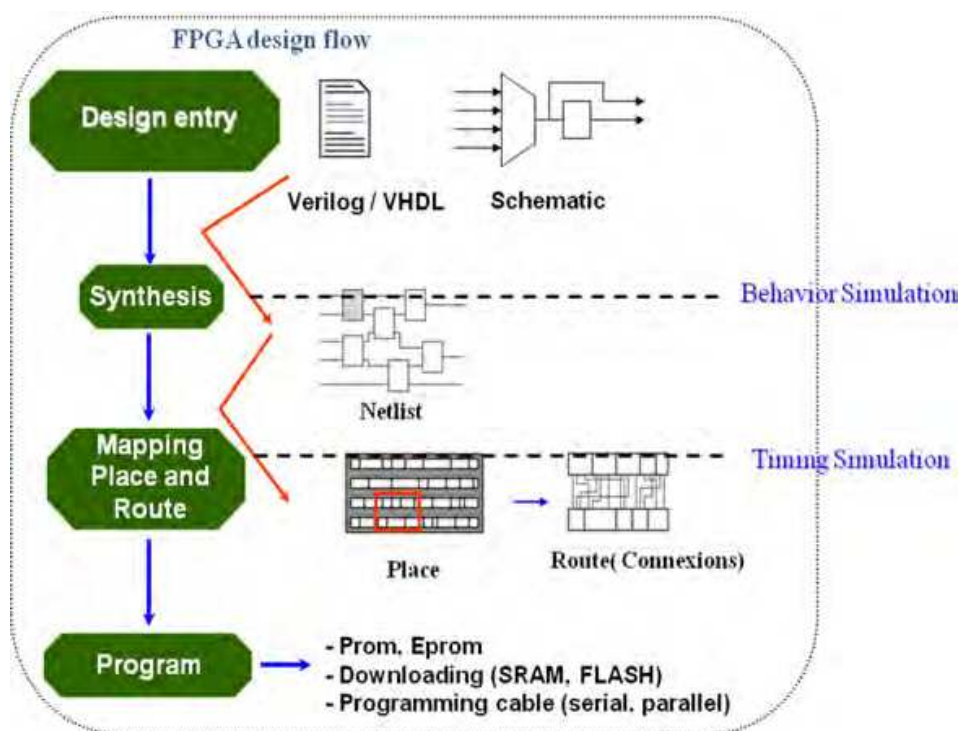

Fig. 14. *FPGA* design flow overview.

During every step of design flow, and by using an automation tool, a technology-mapped netlist is generated. The netlist can be fitted to the *FPGA* architecture using a process called *place-and-route*. Usually these steps are performed by the *FPGA* company's proprietary place-and-route software, such as the *ISE* and *Quartus* tools of the *Xilinx* and *Altera* companies, respectively [Altera2, 2011; Xilinx4, 2008].

The embedded digital system's designers will validate the map, place and route results via simulations for verification and timing analysis obtained during the design process. Furthermore, design verification - which includes both functional verification and timing verification - takes places at different points in the design flow. As mentioned in Figure 14, the functional verification of the design is done before synthesis, corresponding to the running of a behavioural simulation (*RTL* simulation), and after synthesis translation, corresponding at the running of a functional simulation (*gate-level* simulation). Thus, the

RTL description in *VHDL* or *Verilog* is initially simulated by creating test benches to simulate the system and observe the results. Next, the synthesis engine maps the design to a netlist. This netlist is translated to a gate-level description where simulation is repeated to confirm that the synthesis has proceeded without errors. Finally, the design is laid out in the *FPGA*, at which point propagation delays can be added and the simulation then runs again with these values back-annotated into the netlist. Once the design and validation process is complete, a binary file called *bitstream* is generated (also using the *FPGA* company's proprietary software) in order to (re)configure the *FPGA*. Therefore, the programming of the device is made from this programming file, containing the bits to program the specific *FPGA* by using a programming cable or by downloading into the device one memory file containing the *bitstream*. More precisely, the *bitstream* is transferred to the *FPGA/CPLD* via a serial interface (*JTAG - Joint Test Action Group* - standard support) or to an external memory device, such as an *EEPROM* or a *PROM*. Generally, after the device's programming, a circuit verification is done in order to verify the real and final functionality of the design. This final step allows for the specification of real performance in terms of power consumption, work frequency and the required logic, as well as memory hardware resources. Furthermore, in order to simplify the design of complex systems in *FPGAs*, there exist libraries of predefined complex functions and circuits that have been tested and optimised so as to speed up the design process. These predefined circuits are commonly called *IP cores*, and are available from *FPGA* vendors and third-party *IP* suppliers (under proprietary licenses). These modules are available for targeting and programming *FPGA* hardware. Other predefined circuits are also available from developer communities, such as the *OpenCores* site (typically released under free and open-source licenses) [Opencores].

Thanks to such structures, a *FPGA* can be used to implement any logical function that an *ASIC* could perform. The ability to update their functionality after shipping (defined as total or partial chip reconfiguration of a portion of the design and the low non-recurring engineering costs relative to an *ASIC* design) offers advantages for many embedded applications. Thus, the *FPGA* allows for even higher performance by trading off precision and an increased number of parallel arithmetic units. Indeed, the inherent parallelism of the logic resources on a *FPGA* allows for considerable computational throughput, even at low MHz clock-rates. The adoption of *FPGAs* in high performance computing is currently limited by the complexity of *FPGA* design compared with conventional software. Indeed, the *place and route* steps for a complex design may take a long time to succeed.

In the case of the implementation of an embedded chaotic system, an optimised hardware design coded into a *VHDL* with a structural description logic is required. Indeed, the "high level" aspect of one non-optimal *VHDL* code generation keeps the embedded designer far removed from the realities of physical implementation, which does not allow for the optimised performance of the design. Consequently, a result in terms of performance and the density of resources used remains out of the designer's reach. Therefore, the designers of embedded system based on *FPGAs* must find applications in any area or with any algorithm which can make use of the massive parallelism offered by the architecture. One such area is to design one cryptosystem allowing the avoidance of the breaking of the code - in particular brute-force attacks - of cryptographic algorithms carried out by the digital circuit. In this context, and in considering our embedded ciphering application, hardware implementation is designed and coded in *VHDL* with a structural description logic. This *low level* form of design seeks for resolving the *Genesisio-Tesi* differential equation (18) through the

RK-4 numerical resolution method in order to produce a more accurate estimate of the solution [Cartwright & Piro, 1992].

The FPGA implementation presented in the remainder of this section will simulate the correct operation with test vectors returned by the software’s implementation.

5.3 RTL architecture

As to logic exploration architecture, one proposed RTL architecture of the *Genesis-Tesi* chaotic system is depicted by Figure 15. Note that the architecture depends on the three bifurcation parameters a , b and c and is based on the structural feedback of three main blocks: F , G and Q . These three functional units realise the nonlinear functions of the equations (18.a), (18.b) and (18.c), respectively. These units are composed by an adder, a subtractor and multiplier logic arithmetic operators. Consequently, the F and G units correspond to logic assignments while the Q unit is simply composed of an adder, a subtractor and multiplier logic arithmetic operators in accordance with the set of equations (18) and the RK-4 resolution method. The data-path processing architecture of the Q units is depicted by Figure 16.

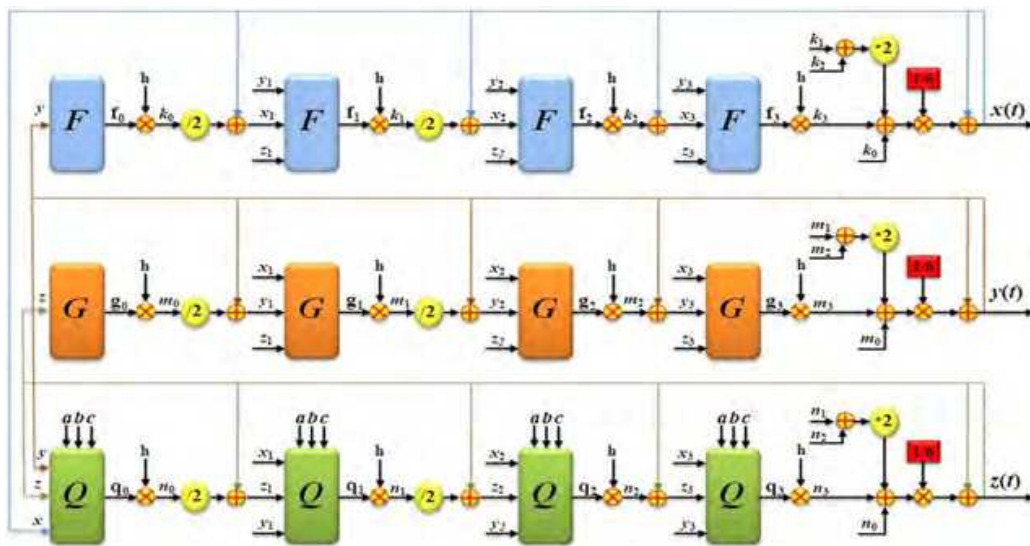

Fig. 15. RTL architecture of the *Genesis-Tesi* chaotic system.

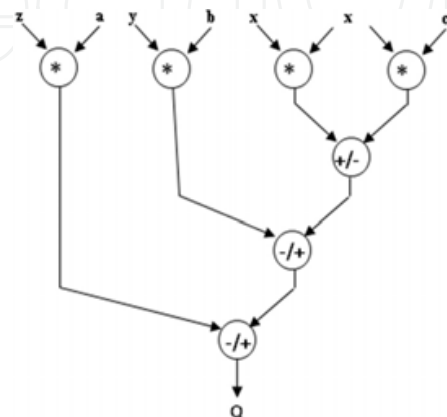

Fig. 16. RTL architecture of the Q functional units.

5.4 Logic hardware modelling and simulation

To test the effectiveness of this microelectronic solution, the *RTL* architecture of the *Genesis-Tesi* generator has been simulated with the *ModelSim* simulator tool [Mentor Graphics, 2008]. Unlike the use of *VHDL* automatic code generation [Aseeri et al., 2002; Sobhy et al., 1999], the data-path processing architecture has been implemented in the structural description in the manner depicted by Figure 15. It should be noted that the continuous chaotic signals are real, which is why the embedded proposed architecture treats a finite resolution of numbers using a binary representation. Indeed, in embedded electronic design, a fixed-point number representation is a real data-type for a number that has a fixed number of digits after the radix point. Fixed-point formats are useful for representing fractional values - usually in base 2 or base 10 - when the executing processor has no *floating point unit (FPU)*, or else if the fixed-point provides improved performance or accuracy for the application. Moreover, most low-cost embedded systems do not have an *FPU*.

In the case study, the data-path architecture adopted one hardware implementation based on a finite solution of numbers with a fixed point representation of the real data in 32 bits (*16Q16*) - i.e., all the data is in a fixed-point format with 16 bits for the integer and fraction parts. This fixed-point arithmetic format allows for a very useful and attractive trade off between high speed and low area cost because the presentation on 32 bits (*16Q16*) provides greater precision for the representation of the real data while preserving the dynamic of the generated chaotic signals. The obtained results are shown by Figure 17, where the chaotic signals *x*, *y* and *z* of the *Genesis-Tesi* generator are presented. Note that all of these results are represented with 32 bits using the bifurcation parameter values as defined in Section 5.1. It can be seen that the *ModelSim* simulation results are very similar to those obtained with the *MatLab* simulations shown in Figure 7.

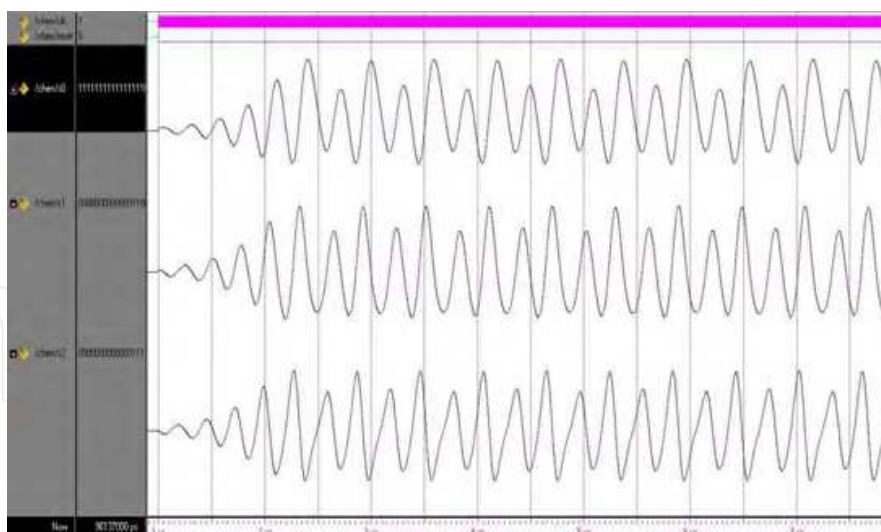

Fig. 17. *ModelSim* simulation results of the chaotic signals *x*, *y* and *z*.

5.5 Logic synthesis results

The *FPGA* synthesis results (after the *place* and *route* steps) in terms of logic resources and performance analysis of the implementation of the architecture inside the *FPGA* are detailed in Table 2. The maximum frequency and hardware resources consumption in terms of the

slices and multipliers required are specified there. The results demonstrate that the proposed *Genesisio-Tesi* chaotic generator can be efficiently implemented through *FPGA* technology by providing real-time chaotic signals. It can be seen that an attractive trade-off between high speed and low logic resources has been achieved. Indeed, their implementation on a Xilinx *Virtex-II* device uses only 1359 *CLB-Slices* (9% of the circuit size), 22 multipliers (16%) and no block *RAMs*. This justifies the advantages of the weak nonlinearity of the *Genesisio-Tesi* chaotic system. To evaluate the behaviour of the proposed hardware implementation, we use certain evaluation metrics. The metrics are the *Throughput rate* and the *Time latency*. The *throughput rate* is defined as the number of bits by unit of time. In our case, this rate corresponds to 32 bits wordlength during one operating clock frequency. From the performance results (see Table 2) we achieved a maximal throughput of 806.62 Mbps. This throughput rate is computed after the initialisation phase at the output of the *FPGA* circuit. Meanwhile, at the input of the *DAC*, the rate corresponds to 18 bits wordlength during one operating clock frequency, and the maximum throughput achieved is 454.64 Mbps. *Latency* is defined as the time necessary to generate one single wordlength signal after the start of the generator. The optimised implementation of the *Genesisio-Tesi* chaotic system requires 8 clock cycles to generate one wordlength chaotic signal. In this case, we obtain a time latency of 316.73 ns. These results are very attractive for the security of communications between embedded systems.

Device utilization summary		
Selected Device : 2vp30ff896-7		
Number of Slices:	1359 out of 13696	9%
Number of Slice Flip Flops:	865 out of 27392	3%
Number of 4 input LUTs:	2591 out of 27392	9%
Number of bonded IOBs:	98 out of 556	17%
Number of MULT18X18s:	22 out of 136	16%
Number of GCLKs:	1 out of 16	6%
Maximum Frequency:	25.258MHz	

Table 2. Synthesis results.

5.6 Physical hardware implementation

In this section, we consider the *XUP Xilinx Virtex-II Pro* Development embedded platform for physical hardware implementation [Xilinx4, 2008]. The *XUP* System consists of a high performance *Virtex-II Pro* *FPGA* (XCV2PFF896-7) surrounded by peripheral components that can be used to create a complex hardware system. Figure 18 displays a photo of the *XUP Xilinx Virtex-II Pro* platform. Note that an audio *CODEC* (AC97) and stereo power amplifier are included on the *XUP* platform so as to provide complete analogue functionality, allowing the external generation of chaotic signals in analogue form for real measurements [Analog Device, 2000].

An overview of the hardware architecture of the key data chaotic generator - implemented on the *XUP Virtex-II Pro* development system - is depicted by Figure 19. The *RTL* architecture has been implemented on *Xilinx Virtex-II Pro* XC2VP30 *FPGA* [Xilinx2, 2007]. This hardware description was designed with the *ISE 10.1 Xilinx* tools [Xilinx4, 2008].

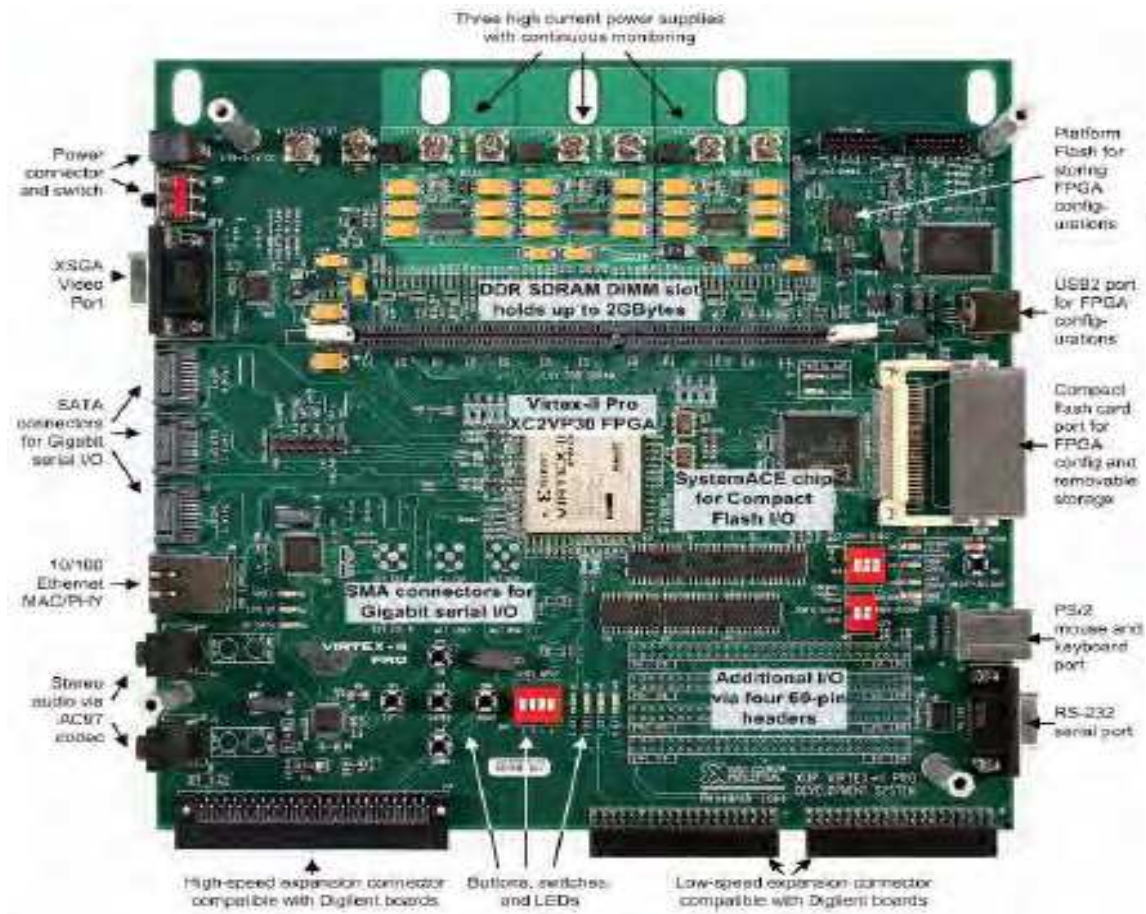

(4pt)

Fig. 18. XUP Xilinx Virtex-II Pro embedded platform.

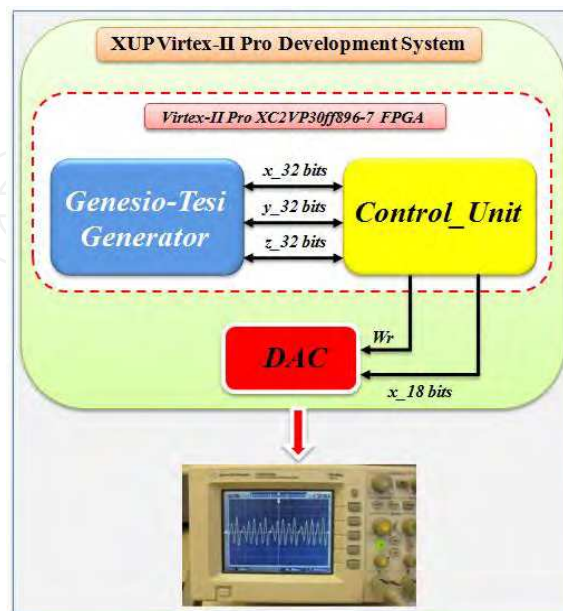

Fig. 19. Digital hardware architecture of the *Genesio-Tesi* chaotic system.

The architecture system consists of two main modules: the *Control_Unit* and the *Genesio-Tesi-Generator* module. The *Control_Unit* module is a *Moore*-state machine which manages and schedules the different operations and functions of the chaotic system. The *Genesio-Tesi-Generator* module generates the chaotic signals as described in Section 5.4. Once the chaotic signals (x , y and z) with 32 bits wordlength are obtained, they are truncated to 18 bits and converted to an analogue format using a *Digital-to-Analogue Converter (DAC)*, and this process is then repeated. Next, the real-time chaotic signals obtained at the output of the *DAC* are visualised via a digital oscilloscope [Agilent, 2007]. Note that this proposed architecture offers two different means for using the obtained real-time chaotic signals. Indeed, it permits the use of them in their analogue form at the output of the *DAC* or their use in their digital form directly at the output of the *FPGA* circuit. This will permit the easy exploitation of the richness of the dynamical behaviour of the embedded *Genesio-Tesi* chaotic generator for such embedded applications as communications security.

To view the real-time chaotic signals generated by the *Genesio* system, we implemented the proposed digital architecture in the *FPGA* Chip of the *XUP Virtex-II Pro FPGA* platform development, and prototyping was then performed. The functional Blocks implemented in the *FPGA* chip are shown by Figure 20. This architecture is mainly composed of three modules, the *clk_generator*, the *genesio_generator* and a digital interface (*BASIC_AC97_INTERFACE*) of the *DAC* available on the *XUP Virtex-II* platform. The functions of each module are:

- *clk_generator*: it generates and distributes the clock and reset signals required for all of the modules. Thus, the signal *clk_AC97* drives the *AC97* codec at 12.5 MHz while the signal *clk_genesio* cadences the *Genesio_generator* module at 25,254 MHz. These signals are generated from the 100 MHz clock embedded on the board system.
- *Genesio_generator*: it generates the chaotic signals x , y and z of 32 wordlength bits and controls the *DAC* operations with a specific control signal (*cmd*).
- *BASIC_AC97_INTERFACE*: this block - after analogue conversion - transmits signals to a chaotic oscillator for digital real-time display.

Note that no block of *RAM* is used in this hardware architecture.

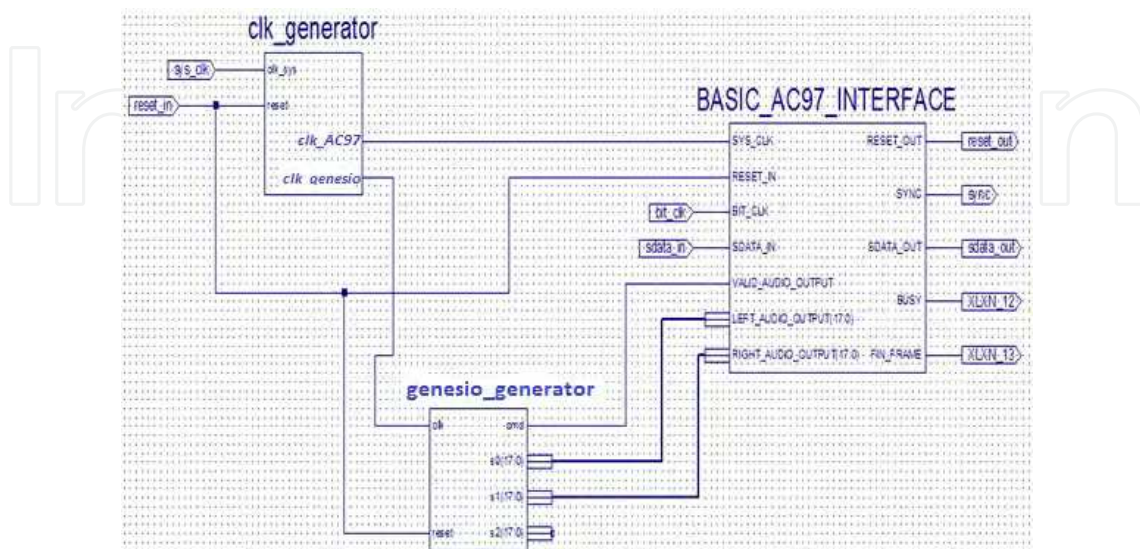

Fig. 20. Functional blocks implemented in the *FPGA* chip.

5.7 Real time measurements

Figures 21 and 22 show the real time measurements of the chaotic signals x , y and z and the strange attractors obtained in the plans $(x-y)$ and $(x-z)$, respectively, which were obtained simultaneously with the presented hardware system. These snapshots are provided by a digital oscilloscope (Tektronix oscilloscope [Agilent, 2007]) at the output of the DAC. The x , y and z real-time chaotic signal measurements of the embedded generator, obtained by the direct implementation of the RTL-optimised architecture, are given by Figures 21.a, 21.b and 21.c, respectively. The measured real-time attractors $(x-z)$ and $(x-y)$ are presented by Figures 22.a and 22.b, respectively. We can compare these real results with those obtained using the *MatLab* and *ModelSim* simulation tools presented in Sections 5.1 and 5.4 in order to ascertain whether or not these results are similar. These results clearly confirm that the implemented chaotic system works well in the chaotic mode. In addition, these measurements show that the proposed approach provides an efficient chaotic generator. Consequently, the hardware implementation validates this approach for the development of embedded chaotic generators based on chaotic nonlinear systems.

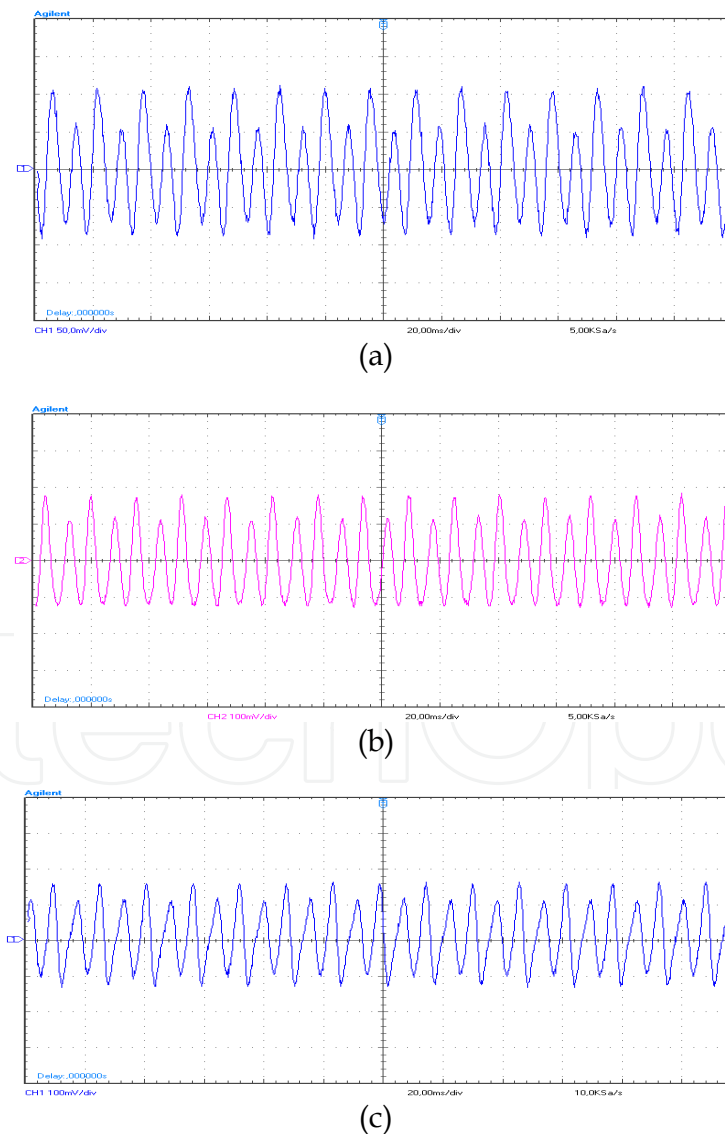

Fig. 21. Real-time measurement results of the chaotic signals x (a), y (b) and z (c).

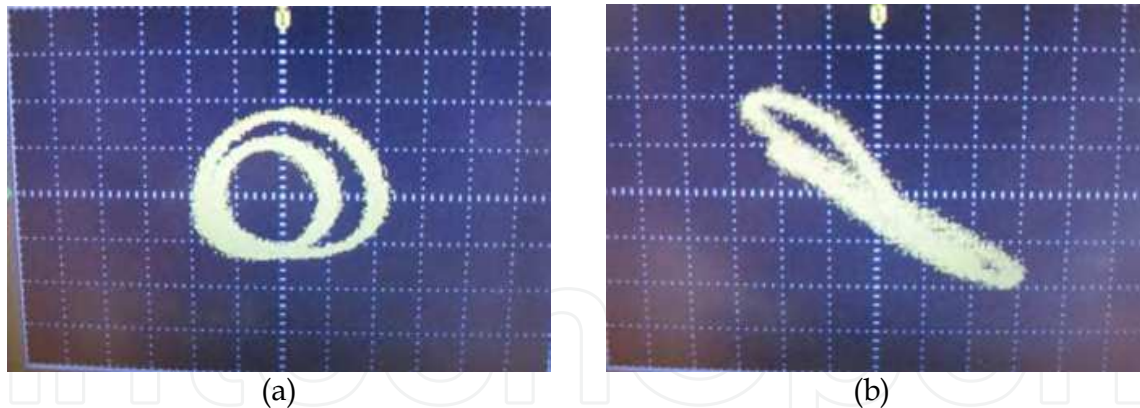

Fig. 22. Real-time measurement results of (a) the $(x-y)$ chaotic attractor, and (b) the $(x-z)$ chaotic attractor.

Figure 23 provides a view of the experimental hardware implementation and measurements of the *Genesisio* $x-y$ chaotic attractor. Real-time measurements and digital acquisition can be made.

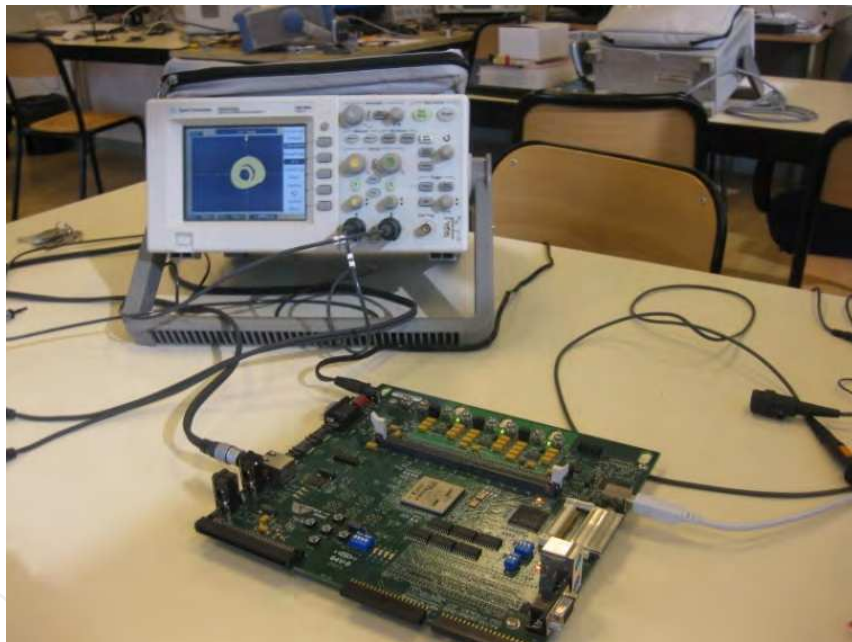

Fig. 23. Photo of the experimental hardware implementation and measurements of the *Genesisio-Tesi* $x-y$ chaotic attractor.

6. Conclusion

Following a general overview of the embedded digital system design based on programmable technology and its associated tools, this chapter presents a hardware design of the embedded system for security applications. One *FPGA* implementation of an embedded chaotic cryptosystem has already been detailed. The implemented embedded system is based on a *3D* chaotic key generator for a high data stream encryption rate suitable for real-time image encryption. The proposed case study provides an efficient approach for conceiving an embedded *Genesisio-Tesi* chaotic generator based on the

implementation of reconfigurable technology. The hardware implementation of this embedded generator gave attractive performances. More precisely, the implementation requires only 1359 CLB-slices, 22 multipliers and no blocks of RAM, and achieves a throughput rate of 808.26 Mbps at the output of the FPGA circuit and 454.64 Mbps at the input of the DAC, with a clock frequency of 25.258 MHz and with a low latency time of 316.73 ns. Thus, the signal generator performs well for embedded applications, such as secure communications based on chaos approach. The random key generator architecture that was presented is particularly attractive, since it provides low-cost secure communications solutions for embedded systems. This approach at hardware design is validated by showing that the real-time *Genesio-Tesi* chaotic signals obtained with the RTL architecture are similar to the software simulations as its counterparts. Moreover, embedded cipher systems can have several advantages over the use of FPGAs. Indeed, the experimental results using the *Xilinx Virtex* technology have demonstrated that the design approach presented can lead to designs with a small logic area, satisfactory throughput rates and low latency for embedded applications.

7. References

- Agilent, (2007). 3000 Series Oscilloscopes data Sheet, Agilent Technologies, 5989-2235.
- Altera. (2011). Nios II Processor, *Reference Handbook*; Available from <http://www.altera.com>
- Altera2, (2011). Quartus II Handbook Version 11.1. Available from http://www.altera.com/literature/hb/qts/quartusii_handbook.pdf
- Analog Device, (2000), AC'97 SoundMAX Codec, *AD1881A Datasheet*.
- Aseeri, M. A.; Sobhy, M. I.; Lee, P. (2002). Lorenz Chaotic Model Using Field Programmable Gate Array (FPGA), *Midwest Symposium on Circuit and Systems*, pp. 686-699.
- Azzaz, M. S.; Tanougast, C.; Sadoudi, S.; Dandache, A. (2011). Robust Chaotic Key Stream Generator for Real Time Images Encryption, *Journal of Real-Time Image Processing*, Springer Verlag, Vol. 6.
- Brown, S.; Rose, J. (1996). FPGA and CPLD architectures: a tutorial, *IEEE Design and Test of Computers*, 13 (2), pp. 42-57.
- Burr, W. E. (2003). Selecting the advanced Encryption Standard, *IEEE Security & Privacy, IEEE Computer Society*, pp. 43-52.
- Carroll, P. L.; Pecora, L. M. (1990). Synchronization in chaotic systems, *Phy. Rev. Lett.*, 64 (8), pp. 821-824.
- Cartwright, J. H. E.; Piro, O. (1992). The Dynamics of Runge-Kutta Methods, *Int. J. Bifurcation and Chaos*, Vol. 2, pp. 427-449.
- Cha, C. Y.; Lee, S. G. (2005). Complementary Colpitts Oscillator in CMOS Technology', *IEEE Transaction on microwave theory and techniques*, 53 (3).
- Chen, H. H ; Chiang, J. S. ; Lin, Y. L. ; Lee, C. I. (2007). Chaos synchronization of general Lorenz, Lü, and Chen systems, *HSIUPING Journal*, Vol. 15, pp. 159-166.
- Compton, K.; Hauck, S. (2002). Reconfigurable computing : a survey of systems and software, *ACM Comput. Surv.*, 34 (2), pp. 171 - 210.
- Cuomo, K. M.; Oppenheim, A. V.; Strogatz, S. H. (1993). Synchronization of Lorenz-Based Chaotic Circuits with Applications to Communications, *IEEE transactions on circuits and systems-11: analog and digital signal processing*, 40 (1), pp. 626-633.

- Genesio, R.; Tesi, A.; Villoresi, F. (1993). A frequency approach for analyzing and controlling chaos in nonlinear circuits, *IEEE Trans. on Circuits Systems I: Fundamental Theory and Applications*. Vol. 40, pp. 819-828.
- Genesio, R.; Tesi, A. (1992). Harmonic balance methods for the analysis of chaotic dynamics in nonlinear systems, *Automatica*, Vol. 28, pp. 531-548.
- Giannakopoulos, K.; Souliotis, G.; Fragoulis, N. (2007). An integratable chaotic oscillator with Current Amplifiers, *IEEE Int Symp. on Signals, Circuits and Systems*, Vol. 1, pp. 1-4.
- Hauck, S. (1998). The role of FPGA in reprogrammable systems, *Proceedings of IEEE*, Vol. 86 (4), pp. 615-638.
- Indrusiak, L. S.; Dutra Silva Junior, E.C. ; Glesner, M. (2005). Advantages of the Linz-Sprott weak nonlinearity on the FPGA implementation of chaotic systems: a comparative analysis, *Proc. Int. Symp. Signals, Circuits and Sys. 2*, pp. 753 - 756.
- Kennedy, M. P. (1994). Chaos in the Colpitts oscillator, *IEEE Trans. Circuits Syst. I*, Vol. 41, pp. 771-774.
- Kvarda, P. (2002). Investigating the Rössler attractor using Lorenz plot and Lyapunov exponents, *Radio Engineering*. 11 (3), pp. 22-23.
- Liu, T.; Tanougast, C.; Brunet, P.; Berviller, Y.; Rabah H.; Weber, S. (2005). An Optimized FPGA Implementation of an AES Algorithm for Embedded Applications, *The International Workshop on Applied Reconfigurable Computing*, pp. 111-118.
- Lorenz, T E.N. (1963). Deterministic nonperiodic flow, *Journal of the Atmospheric Sciences*, 20 (2), pp. 130-141.
- Lü, J.; Chen, G. (2002). A new chaotic attractor coined, *Int. Journal of Bifurcation and Chaos*, 12 (3), pp. 659-661.
- Mathworks (2006), MatLab Software, Version 7.3, *Mathworks*.
- Matsumoto, T. (1987). Chaos in electronic circuits, *Proc of the IEEE*, Vol. 75 (8), pp. 1033-1046.
- Mentor Graphics, (2008). Modelsim SE User's Manuel, Software, Version 6. 4, Mentor Graphics.
- Opencores, Available from <http://opencores.org>.
- Ozoguz, S. ; Ates, O.; Elwakil, A. S. O. (2005). An integrated circuit chaotic oscillator and its application for high speed random bit generation, *ISCAS 2005*, Vol. 5, pp. 4345-4348.
- Park, J. H. (2007). Exponential Synchronization of the Genesio-Tesi Chaotic System via a Novel Feedback Control," *Phys.Scr.*, Vol. 76, pp. 617-622.
- Sadoudi, S.; Tanougast, C.; Azzaz, M.; Bouridane, A. Dandache, A. (2010). Embedded Genesio-Tesi Chaotic Generator for cipher communications, *7th IEEE, IET International Symposium on Communication Systems, Networks and Digital Signal Processing*, pp. 234 - 238.
- Sobhy, M. I.; Aseeri, M. A.; Shehata, A. E. R. (1999). Real Time Implementation Of Continuous (Chua And Lorenz) Chaotic Generator Models Using Digital Hardware, *Proc. of the Third International Symposium on Communication Systems Networks and Digital Processing*, pp. 38-41.
- Sorel, Y. (1994). Massively parallel systems with real time constraints, the algorithm architecture adequation methodology, *In Proceedings of Conference on Massively Parallel Computing Systems*, May 1994, pp. 44 - 53.

- Tanougast, C.; Berviller, Y.; Weber, S.; Brunet, P. (2003). A partitioning methodology that optimises the area on reconfigurable real-time embedded systems, *EURASIP Journal On Applied Signal Processing, Special Issue on Rapid Prototyping of DSP Systems*, Vol. (6), pp. 494-501.
- Tanougast, C.; Berviller, Y.; Brunet, P.; Weber, S.; Rabah, H. (2003). Temporal partitioning methodology optimizing FPGA resources for dynamically reconfigurable embedded real-time system, *Microprocessors and Microsystems, Elsevier*, 27 (3), pp. 115-130.
- Yang, T. (2004). A survey of chaotic secure communication systems, *International Journal of Computational Cognition*, 2 (2), pp. 81-130.
- Yang, Cao, Chung and Morris, (2005). *Applied Numerical Methods Using MATLAB*, John Wiley, and Sons, Inc.
- Xilinx1. (2008). MicroBlaze Processor, *Reference Guide Embedded Development Kit EDK 10.1i*, UG081 (v9.0). Available from http://www.xilinx.com/support/documentation/sw_manuals/mb_ref_guide.pdf
- Xilinx2, (2007). VirtexII complete Datasheet. Available from http://www.xilinx.com/support/documentation/data_sheets/ds031.pdf.
- Xilinx3, (2000). Xilinx Data Sheet DS003 (v.2.2).
- Xilinx, (2008). Virtex5 FPGA Data Sheet, 2008. Available from http://www.xilinx.com/support/documentation/data_sheets/ds202.pdf.
- Xilinx4, (2008). Integrated Software Environment (ISE), Version 10.1, Available from <http://www.xilinx.com/support/documentation>
- Xilinx4, (2008). Xilinx University Program Virtex-II Pro Development System, *Xilinx, UG069 (v1.1)*.

IntechOpen

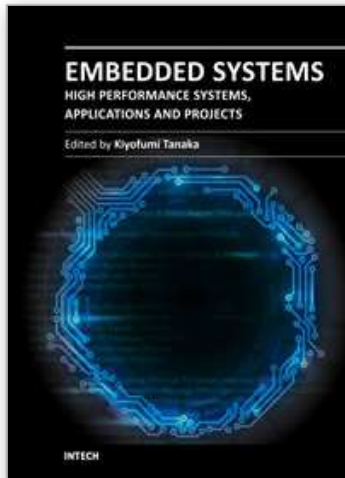

Embedded Systems - High Performance Systems, Applications and Projects

Edited by Dr. Kiyofumi Tanaka

ISBN 978-953-51-0350-9

Hard cover, 278 pages

Publisher InTech

Published online 16, March, 2012

Published in print edition March, 2012

Nowadays, embedded systems - computer systems that are embedded in various kinds of devices and play an important role of specific control functions, have permeated various scenes of industry. Therefore, we can hardly discuss our life or society from now onwards without referring to embedded systems. For wide-ranging embedded systems to continue their growth, a number of high-quality fundamental and applied researches are indispensable. This book contains 13 excellent chapters and addresses a wide spectrum of research topics of embedded systems, including parallel computing, communication architecture, application-specific systems, and embedded systems projects. Embedded systems can be made only after fusing miscellaneous technologies together. Various technologies condensed in this book as well as in the complementary book "Embedded Systems - Theory and Design Methodology", will be helpful to researchers and engineers around the world.

How to reference

In order to correctly reference this scholarly work, feel free to copy and paste the following:

Camel Tanougast, Abbas Dandache, Mohamed Salah Azzaz and Said Sadoudi (2012). Hardware Design of Embedded Systems for Security Applications, Embedded Systems - High Performance Systems, Applications and Projects, Dr. Kiyofumi Tanaka (Ed.), ISBN: 978-953-51-0350-9, InTech, Available from: <http://www.intechopen.com/books/embedded-systems-high-performance-systems-applications-and-projects/hardware-design-of-embedded-systems-for-security-applications>

INTECH
open science | open minds

InTech Europe

University Campus STeP Ri
Slavka Krautzeka 83/A
51000 Rijeka, Croatia
Phone: +385 (51) 770 447
Fax: +385 (51) 686 166
www.intechopen.com

InTech China

Unit 405, Office Block, Hotel Equatorial Shanghai
No.65, Yan An Road (West), Shanghai, 200040, China
中国上海市延安西路65号上海国际贵都大饭店办公楼405单元
Phone: +86-21-62489820
Fax: +86-21-62489821

© 2012 The Author(s). Licensee IntechOpen. This is an open access article distributed under the terms of the [Creative Commons Attribution 3.0 License](#), which permits unrestricted use, distribution, and reproduction in any medium, provided the original work is properly cited.

IntechOpen

IntechOpen