

# We are IntechOpen, the world's leading publisher of Open Access books Built by scientists, for scientists

**4,800**

Open access books available

**122,000**

International authors and editors

**135M**

Downloads

Our authors are among the

**154**

Countries delivered to

**TOP 1%**

most cited scientists

**12.2%**

Contributors from top 500 universities



**WEB OF SCIENCE™**

Selection of our books indexed in the Book Citation Index  
in Web of Science™ Core Collection (BKCI)

Interested in publishing with us?  
Contact [book.department@intechopen.com](mailto:book.department@intechopen.com)

Numbers displayed above are based on latest data collected.

For more information visit [www.intechopen.com](http://www.intechopen.com)



# Integration of Small Hydro Turbines into Existing Water Infrastructures

Aline Choulot<sup>1</sup> Vincent Denis<sup>1</sup>, and Petras Punys<sup>2</sup>

<sup>1</sup>Mini-Hydraulics Laboratory (Mhylab),

<sup>2</sup>Water & Land Management Faculty,  
Lithuanian University of Agriculture,

<sup>1</sup>Switzerland,

<sup>2</sup>Lithuania

## 1. Introduction

Climate change due to CO<sub>2</sub> emissions has been defined as the major environmental challenge to be faced nowadays by the International Community. The European Directive 2009/28/EC of 23 April 2009 on the Promotion of Renewable Energy aims at achieving by 2020 a 20% share of energy from renewable sources in the EU's final consumption of energy. Each EU Member State adopted a national renewable energy action plan (NREAP) setting out its national targets for the share of energy from renewable sources consumed in transport, electricity, heating and cooling in 2020.

The public awareness on environmental topics has improved significantly, leading to a European environmental awareness. One of the latest manifestations of this awareness is the European Water Framework Directive (2000/60/EC), aiming at an overall protection of water. But this Directive tends to be in contradiction with the above mentioned directive, slowing down the development of hydropower including small hydropower plants (SHP). However, there is no doubt about the benefits of converting energy by SHP plants that means climate change mitigation and security of energy supply. Then, it implies regional development and employment. On a local level, SHP integration into the local environment, optimal use of water resource and mitigation measures are now key words for SHP design and implementation, which can lead to creation of positive impacts on the local ecosystem (Chenal et al. 2009).

Multipurpose hydro schemes, which lead to energy recovery in existing infrastructures thanks to hydropower plants, are one of the rare issues that may perfectly respect both the "Renewable Energy Directive" and the "Water Framework Directive". In addition, it can offer a solution to many potential issues discussed on water policy when it comes to sustainable management of the resource in sectors like agriculture, inland navigation, wastewater treatment or drinking water supply. In other words there is a significant market niche of this "sleeping" hydro potential. Even extremely small water infrastructures can generate hydropower - including the systems that deliver water to homes or subsequently scrub it of pollutants. Anywhere there is excess head pressure in a infrastructure dealing with water; there can be a good opportunity to generate electricity.

This chapter is meant to answer two main questions:

- Where are the potentials stemming from a water infrastructure?
- How (technically) can energy be recovered by a small turbine or unconventional small hydropower plant?

To answer these questions the overall objectives were to:

- Identify potentials for non traditional hydropower installations,
- Review main steps for development of a multipurpose project,
- Provide typical recommendations for installing SHP plants into existing infrastructures,
- Summarise good practices of these technologies based on cases studies,

Main findings of this study are based on a specific Swiss experience and the expertise of Mhylab (Mini-Hydraulics Laboratory). The SHAPES project outcome - Energy recovery in existing infrastructures with small hydropower plants (ESHA et al., 2010) is here used extensively, with some to the most relevant cases studies, collected all over the European Union and Switzerland. Table 1 presents these 16 case studies, with their main characteristics (nominal discharge, gross head, electrical output and electrical production), while their description and main peculiarities will be developed through different sections as referred in the last column of this Table 1.

Moreover, a variety of information resulting from a range of publications in open sources, conference proceedings, internet resources and case studies on the application of energy recovery were collected and analysed.

## 2. Overview of small hydropower

Hydropower plants are divided into two main areas: the "large" and the "small" ones. At present time there is no satisfying definition to determine if a hydropower plant is small or large. This differentiation depends on a multitude of criteria, such as the output of the scheme and its size or technical or economic characteristics.

The criterion currently used for defining small hydropower plants is that of output, but many variants are in use. Eurelectric, the European Commission, ESHA (European Small Hydropower Association) as well as several other countries have defined a scheme of less than 10 MW as being small (Chenal et al., 2009).

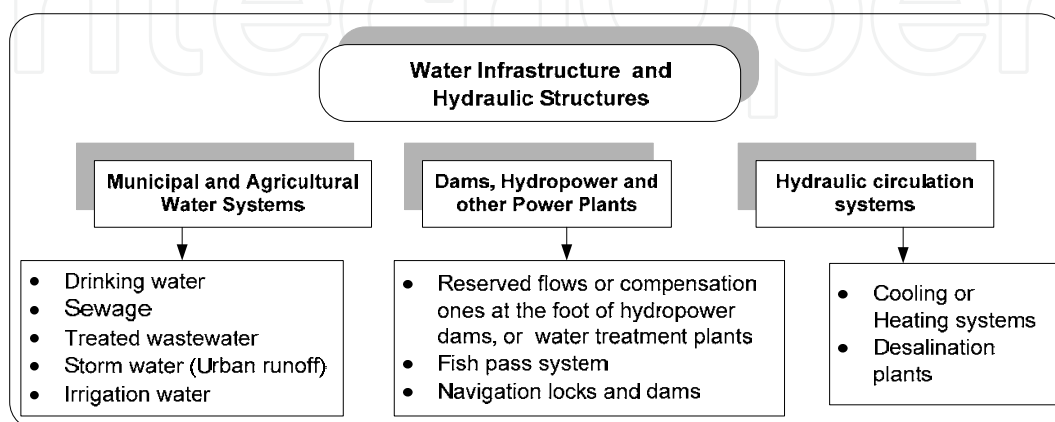

Fig. 1. Components of the water industry covered by this analysis.

Existing infrastructures	Power plant name and Country	Nominal discharge (m <sup>3</sup> /s)	Gross head (m)	Electrical output (kW)	Electrical production (GWh/year)	Section
Drinking water network	La Zour, CH	0.30	217	465	1.8	3.2.1
	Mühlau, AT	1.60	445	5750	34.0	3.2.1
	Poggio Cuculo, IT	0.38	28	44	0.36	3.2.1, 5.3.2, 5.3.5
Irrigation network	Armary, CH	0.09	105	68	0.45	3.2.2
	Marchfeldkanal, AT	6.00	2	70	0.50	3.2.2
	Rino, IT	0.78	446	2800	14.00	3.2.2
Raw wastewater network	Le Châble, Profray, CH	0.10	449	380	0.85	3.2.3, 5.3.2, 5.5
Treated wastewater network	Seefeld, AT	0.25	625	1192	5.50	3.2.3
	Nyon, CH	0.29	94	220	0.70	3.2.3, 5.3.2
Hydropower dam and reserved flow	Llys y Fran, UK	0.16	25	29	0.22	3.2.5, 5.3.2
	Le Day, CH	0.60	27	126	0.58	3.2.5
Hydropower dam and fish pass	Aire-la-Ville, CH	2.00	21	348	2.72	3.2.6, 5.3.2
Navigation lock	L'Ame, FR	10.80	2	145	0.65	3.2.7
Desalination plant	Tordera, ES	0.11	685	720		3.2.8
Cooling system	Sangüesa, ES	1.16	11	75	0.50	3.2.9
	Skawina, PL	23.30	8	1560	6.39	3.2.9

Table 1. Selected European case studies of multipurpose schemes (ESHA et al., 2010).

Here the chapter deals with small hydropower plants that can operate as auxiliary installations into municipal and agricultural water systems, hydraulic structures, power plants, desalination plants, heating or cooling systems, while guarantying their primary functions (Fig. 1).

### 3. Where are the potentials?

#### 3.1 Potential estimation

Hydropower depends on two main parameters: the head (or the pressure), and the discharge. Therefore any process implying a water discharge, steady or not, and an unused pressure, is a potential energy source.

Nowadays and worldwide, the multipurpose schemes operating in the water industry equipped with small hydropower plants are limited. For example, no one has been identified in the Baltic countries. Moreover there is a lack of data in Europe concerning the

operating and remaining potential, apart from Switzerland, as shown in Table 2. Can it be then implied that the remaining potentials can be interesting?

Water network type	Potential type	Number of sites	Output (MW)	Production (GWh/year)	Electricity consumption equivalent households
Drinking water	Operating	90	17.8	80	17780
	Remaining	380	38.9	175	38890
Untreated wastewater	Operating	3	0.4	1,4	310
	Remaining	86	7.1	32	7110
Treated wastewater	Operating	6	0.7	2.9	640
	Remaining	44	4.2	19	4220

Table 2. Hydropower schemes in the water industry in Switzerland: operating and remaining potential (Chenal et al., 1994; SFOE, 1995).

To better promote energy recovery within water networks, the Swiss Federal Office of Energy has produced guidelines for installing SHP plants (SFOE, 1996). It can be noted that the Swiss software tool TURBEAU can help in estimating the cost efficiency of the identified potentials (Boillat et al., 2010).

### 3.2 Typical potential sites

These potentials, for which electricity generation is not their primary priority, but the second, are so called **multipurpose schemes**. This implies the integration of the power plant in the existing infrastructure while guaranteeing its primary function. For example, for a drinking water network, the primary priority is to supply in quantity and quality the needed water; whilst for a desalination plant, it is to generate drinking water from sea water. Most of the time the respect of the primary function will imply the setting of a bypass of the turbine as mentioned in chapter § 5.7.

As multipurpose schemes are characterized by a wide range of water quality, from drinking water to wastewater, there is a need for an overview of different techniques.

#### 3.2.1 Drinking water network

A simple drinking-water network can be described as follows (Fig. 2):

- a spring at altitude,
- a forebay,
- a penstock,
- a reservoir,
- a water supply network.

From the elevation of the sources, and as the pressure at the consumers cannot generally exceed 4 bars, there can be an excess of pressure in the networks to recover. The main idea here is to replace the pressure breakers, used traditionally to waste the excess pressure, by turbines so as to generate electricity.

Different energy recovery possibilities can be identified and defined by the turbine positions:

- on a reservoir:

Water passes through the turbine before being accumulated in a reservoir. This method is the most flexible, as it permits disconnection of the turbine operation from the water supply network to guarantee at any time the primary function of the existing infrastructure.

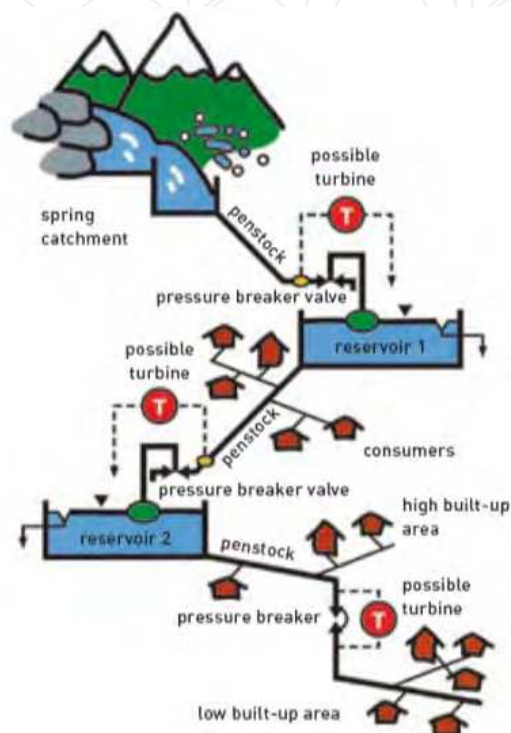

Fig. 2. Layout of a drinking-water network and possible positions of the turbines.

- within the supply network:

Water passes through the turbine and carries on its way through the pipe. This setting means that a pressure defined by the network requirements has to be maintained at the turbine outlet, which reaction turbines and counter pressure Pelton can achieve (cf. section § 5.3).

- before restitution to the environment:

Excess water that is not supplied to the consumers passes through the turbine before restitution to the environment.

When the drinking water source is underground and has to be pumped to the reservoir, no turbine integration will be possible.

- Case study, La Zour, Switzerland<sup>1</sup>: The drinking water system of Savièse commune had to be upgraded in anticipation of population growth, increases in per-capita water

<sup>1</sup> All the characteristics (nominal discharge, gross head, electrical output, electrical production) of the case studies are presented in Table 1.

consumption, and glacier retreat. In the scope of this project, two small hydro schemes (250 kW and 330 kW) were commissioned in 2001, La Zour scheme in 2004 (cf. Photo 1 and Photo 29) and a fourth one in 2009. The performances of the three first hydro plants are to the expected level. The fact that the commune has recently ordered a fourth turbine demonstrates the technical and economic attractiveness of these kinds of SHP developments.

- Case study, Mülhau, Austria: The plant that collects water in a tunnel more than 1.6 km long (the average time the water takes to pass through the rock mass and into the tunnel is estimated at 10 years), supplies drinking water for the major part of Innsbruck. With a generating capacity of 6 MW (cf. Photo 2), it is one of the biggest drinking water power plants in Austria.
- Case study, Poggio Cuculo, Italy: The Poggio Cuculo water treatment plant, which supplies drinking water to Arezzo main reservoir, operates with three different raw water discharges supplied by a large upstream reservoir, depending on the electricity price: 280 l/s during the day, 360 l/s during the winter night and 380 l/s during the summer night.

As the difference of levels between an intermediate reservoir and the water treatment plant is 28 meters, a turbine has been set as a by-pass of the former regulation valve (cf. Fig. 7). This means that the raw water discharges through the hydro turbine before entering the water treatment works for processing.

Although the pipeline related head loss is considerable for the 3 operational discharges (the efficiency of the penstock is 45% only for 380 l/s), the existing pipe work could not be changed for administrative and cost reasons. However, thanks to a runner with 8 adjustable blades (cf. Photo 28) and a variable turbine rotation speed, the turbine can be operated with good hydraulic efficiency under any of the three operating discharges. Moreover the turbine has become the discharge regulation device for the treatment plant inlet, thanks to automation of the runner blade adjustment.

The water treatment plant consumes more than 2 GWh/year of electrical energy, to be compared to the 0.36 GWh/year generated by the small hydropower plant.



Photo 1. La Zour: the setting of the runner and the generator.



Photo 2. Mülhau: Drinking water turbine (2-nozzle Pelton turbine).

One of the first hydropower plants on the drinking-water network in Europe was erected on the drinking water pipe running down to Lausanne, Switzerland, in 1901. The power plant, Sonzier, still operates nowadays, with an output of 1.6 MW and a yearly production of 6.6 GWh, or the electricity consumption of 1470 European households<sup>2</sup>.

On the agenda of a recent SHP conference organised in Lausanne (Switzerland, 2010) , one of many items discussed was the multipurpose hydro schemes under which electricity generation in drinking water supply networks were deeply analysed. A number of case studies were presented (Krasteva, 2010; Toader et al., 2010; Bischoff, V. & Salamin, 2010). Conception and design of a micro-hydro in a water supply system are discussed in Ramos et al. (2010). A US based company proposed a turbine that can be used instead of the pressure-reducing valves found throughout municipal water systems (Bodin, 2008). Rather than overcoming the resistance of a valve's spring-loaded diaphragm, the energy of the water drives the turbine. A similar project was realised at another water supply system with installation of a hydropower system by replacing a pressure reducing valve (White, 2011).

### 3.2.2 Within an irrigation network

The potentials available within an irrigation network are similar to the ones on a drinking water network. The SHP project has to be flexible enough to maximise the electricity production the whole year and not only during the irrigation period (Giacopelli & Mazzoleni, 2009).

- Case study Armary, Switzerland: Historically, the Armary, a small water stream, was used to irrigate the lands of Allaman castle. Before the hydro scheme implementation, the farmers used diesel driven pumps to irrigate their fields during the summer season. In 2006, a penstock was installed as a by-pass to the stream, still fed with a reserved flow, connected to a turbine and to spraying devices in the fields (145 hectares) for irrigation.

The turbine discharge regulation is the water level of the forebay. Using this parameter allows the turbine to operate automatically even during the irrigation season. When the farmers are irrigating their fields, the forebay level drops causing the turbine discharge to be reduced or even stopped. As the turbine is equipped with two jets, it operates with good efficiency even on low part-flow discharges.

In this way, water is available for the farmers at the pressure directly suitable for their spraying equipment (10 bars). Therefore, pumping is no longer necessary, which has reduced CO<sub>2</sub> related emissions. Water is also available all year round for the hydro plant (cf. Photo 3).

- Case study Marchfeldkanal, Austria: The existing irrigation channel system is about 20 km long and comprises 8 weirs equipped with flap gates to regulate the water level. The highest weir was selected to implement a small hydropower plant upon (cf. Photo 4). All the irrigation operational requirements have been safeguarded. The system is an unusual one in that it uses a so-called "hydraulic coupling". Both turbines

---

<sup>2</sup> The average electrical consumption of a European household is estimated here at 4,500 kWh/year.



are connected indirectly to a unique generator via oil hydraulic pumps. The hydraulic pumps drive a hydraulic motor, which then drives the electrical generator.

The purpose of the hydraulic coupling is to replace the two-speed increasers and two generators by two pumps, one motor/generator and an oil pressure unit. The hydraulic circuit gives freedom to locate the motor/generator at a distance of 10 meters from the turbines, on the bank of the water course. The first advantage of this arrangement is that the size of the complete installation is substantially reduced. The second advantage is that the location of all the electrical equipment is on the bank well clear of flooding and easily accessible. Due to the additional stages in the energy conversion process, losses are increased, something that was underestimated at the start of the project. The overall efficiency may be between 60 - 70%. The annual output (0.5 GWh/year) is due to the considerable discharges available in the channel, which is itself fed by the Danube River.



Photo 3. Armary: the power house.



Photo 4. Marchfeldkanal: the turbines.



Photo 5. Rino: recreation area around the basin.



Photo 6. Rino: a view of the power station.

- Case study Rino, Italy: The multipurpose use of water in an Alpine Park (hydroelectric production + tourist attraction + irrigation) makes the Rino hydroelectric plant (cf. Photo 6) an interesting example of how to balance the temporary use of natural resources with considerable environmental constraints. The small basin permits transfer part of the daily production from the off-peak hours to the peak ones. This has been designed to be an attractive place for the tourist activities (angling, picnic, recreation).

The plant was designed to exploit the variation of water levels in the basin, which is kept between precise limits in July and August so that it can be utilised for angling. The tourist use of the basin has been improved by the construction of a recreation area nearby (wood, picnic sites, fountains, toilets block) (cf. Photo 5). The tail race of the hydroelectric plant supplies screened de-silted and regulated water to a sprinkler irrigation plant.

The success of this project, being in a park environment, shows that carefully designed small hydro development is compatible with sensitive management of the environment and with other enterprises (such as agriculture and tourism). The aim of the project was not only to respect these activities but, when possible, to enhance them.

### 3.2.3 Wastewater treatment plant

There are two possibilities to generate electricity from wastewaters (Fig. 3). The first one is before the wastewater treatment plant (WWTP). In such case, the wastewater network of a built-up area will lead to a forebay equipped with a thin trash rack and a rack cleaner. The wastewater is then led through a penstock to the WWTP, situated at a lower elevation, where it passes through the turbine before being treated through the usual process.

The turbine has to be set as close as possible to the elevation of the treatment basin to maximise the head.

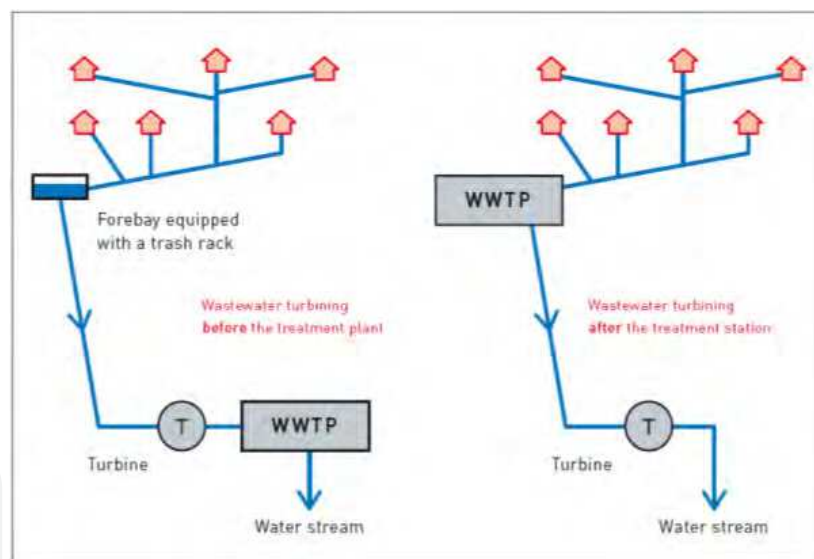

Fig. 3. Turbine setting before and after the wastewater treatment plant (WWTP).

Case study Le Châble Profray, Switzerland: The wastewater from the outlets of the Verbier ski resort is collected in a storage basin of 400 m<sup>3</sup>, equipped with a 6 mm trash rack to remove floating material. This basin is now also used as a forebay for a hydro scheme where the power house is located at a distance of 2.3 km below within the treatment plant (cf. Photo 7). After passing through the hydro turbine (cf. Photo 8, Photo 37 and Photo 38), the wastewater discharges into the treatment plant inlet before finally being re-introduced to a nearby water stream. A bypass is incorporated to guarantee the wastewater treatment operation, whether or not the hydro plant is operational, and for times when the plant operational discharges need to be greater than the turbine maximum discharge.



Photo 7. Le Châble Profray: The valley and the wastewater treatment plant where the turbine is set.



Photo 8. Le Châble Profray: The turbine and its runner and the alternator, during the erection.

The second possibility is after the WWTP. In this case, the treated water that comes out of the WWTP is led down through a penstock to a turbine before being discharged to a lake or a water stream. To maximize the head, the turbine will then be close to this restitution.

For some sites, the hydropower project can lead to improving the cost efficiency of a longer penstock to reach a water stream where dilution can be more significant.

- Case study Seefeld, Austria: To reach the Inn River, the treated wastewater from Seefeld wastewater treatment plant needs to be pumped to pass over a hill and then discharges to the hydropower plant. After the turbine (cf. Photo 10), the water passes through a de-foaming plant and then is discharged into the Inn River, meeting the dilution criteria for treated wastewaters. To guarantee these discharges, a permanently available bypass with energy dissipation is installed. The turbine and its bypass are integrated in a central process control system for automatic operation.  
The project feasibility is justified by the site topology. The hill between the sewage plant and the Inn River is a relatively small percentage of the over gross head available (head for the pumps: 94 m / head for the turbine: 625 m). Note that the electricity generation from this scheme exceeds both the pump energy consumption (1.5 GWh/year) as well as the wastewater treatment plant consumption (0.5 GWh/year) so that excess local generation can be exported onto the grid network. Additionally, by discharging the treated wastewater into a larger receiving stream, the local ecology is improved. A creative approach has been to the architecture of the power house: a water droplet shape creates a thought provoking image for the general public (cf. Photo 9).
- Case study Nyon, Switzerland: In the 1990's, due to a lack of space near Geneva Lake, the new wastewater treatment plant (WWTP) of Nyon City was built 110 meters higher on the plateau. Since then wastewaters are collected in a basin close to the lake, pre-treated, and then pumped to the WWTP where they are treated. Then they pass through a turbine before their discharge to the lake.

The electricity production (0.7 GWh/year) represents half of the pumps consumption, and the third of the water treatment one.



Photo 9. Seefeld: the power house.



Photo 10. The turbine using treated wastewaters.

It can be noted that both possibilities can be technically implemented. As Samra project in Jordan is an example of electricity production from wastewaters before and after the water treatment plant (cf. Photo 11-14). This project at the time was one of the largest of its kind in the world considering the output (2 x 830 kW and 2 x 807 kW). The electrical energy balance can also be pointed out: 90 % of the electrical consumption of the wastewater treatment plant is covered by these hydropower plants and an anaerobic digestion process (Denis, 2007; 2008).

Using wastewater flows to make power is a relatively new idea, but not unprecedented. As for drinking water networks, hydropower production from wastewater flows is also popular in Switzerland (Chenal et al., 1994; SFOE, 1995).

Vienna's main wastewater treatment plant is one of the biggest and most technically advanced sewage treatment facilities in Europe and this requires an enormous input of energy. The concept made use of the existing gradient between the plant outlet and the receiving water – the Danube Canal, along which some 6.5 m<sup>3</sup>/s of purified effluents are discharged from the treatment plant per day. Based on the current amount of effluents and a level difference of 5 m between headwater and tail water, the use of a turbine typically designed for small hydropower plants presented itself as a viable option (some 400 kW capacity) (Hahn, 2009).

The US based the Low Impact Hydropower Institute's (LIHI) highly certified the Massachusetts Water Resource Authority's Deer Island hydroelectric project at its WWTP (LIHI, 2009). Once treated wastewater is disinfected, it is discharged into effluent channels and transmitted through to two corresponding hydro turbines (each 1 MW Kaplan).

Australia's North Head Sewage Treatment Plant started up a 4.5-MW small hydro unit that harvests power from treated wastewater falling down a 60-meter shaft. Along with a methane gas cogeneration unit that was also recently installed, this plant now generates nearly 40% of its own power (Patel, 2010).



Photo 11. As Samra hydropower plant and wastewater treatment plant inlet structure.



Photo 12. As Samra hydropower plant on the treated wastewater.



Photo 13. Two 5 nozzle Pelton turbines set on the raw wastewaters of Amman City, As Samra plants (Jordan) ( $H = 104$  m,  $Q = 2 \times 1.25$  m<sup>3</sup>/s,  $P = 2 \times 830$  kW,  $E = 12.5$  GWh/year, 2007).



Photo 14. Two Francis turbine set on the treated wastewaters of Amman City, As Samra plants (Jordan) ( $H = 42$  m,  $Q = 2 \times 2.3$  m<sup>3</sup>/s,  $P = 2 \times 807$  kW,  $E = 8.6$  GWh/year, 2007).

### 3.2.4 Within a urban runoff collection system

The type of potentials available within a runoff collection system is similar to the ones on a drinking water network. The main issues are the particles carried by the water through the turbine and irregularity of the discharges, which can be managed by accumulation.

### 3.2.5 On a reserved flow or compensation discharge

In most developed countries, water withdrawal from a river goes by the definition of an environmental body of a minimal flow to be maintained in the river, the amount and variability depending on national laws. This flow, called reserved, environmental or compensation discharge, is discharged to the rivers at the foot of weirs or dams built for

hydropower schemes or water treatment works. Thus this implies a loss of electricity for the hydropower schemes (Pelikan, 2005). But an energy recovery is possible by setting a SHP plant at the foot of the weir or dam to use this reserved flow and the difference of levels between the upstream water level in the basin and the level of the water restitution to the river.

- Case study Llys y Fran, United Kingdom: In the United Kingdom, abstractors of water normally have an abstraction license from the Environment Agency, that defines a compensation flow to be maintained in the river at all times. Llys y Fran water treatment scheme, located near the Preseli Mountains in Pembrokeshire, is composed of a dam built on a river (cf. Photo 15) to accumulate water that will be then treated before consumption. As a compensation discharge of 160 l/s is required, and thanks to the difference of levels between the reservoir water levels and the foot of the dam, a turbine has been set that generates around 0.2 GWh/year.

The existing hydro scheme commissioned in the early 1970s was underutilised, mainly because of a lack of automation. The main issues dealt with working on an operational site where the priority lay with delivering raw water for treatment, whilst at the same time, making sure that the compensation discharge was not affected. In 2008, the hydro plant operation was refurbished and automated, whilst the compliant grid connection was facilitated.



Photo 15. Llys y Fran: the dam.



Photo 16. Le Day: The foot of the dam where the small power plant will be set.

- Case study Le Day, Switzerland: Le Day dam (cf. Photo 16) was built in the 1950s on the Orbe River to feed the underground power plant of Les Clées (27 MW) and Montcherand (14 MW). At the foot of the dam are located the valve chamber and the penstock that leads to Les Clées power plant. In Switzerland, from the federal law on water power use (from 1916 and revised in 2008), to let a reserved flow at the foot of dams becomes mandatory five years at the latest after the concession expiry. Although the concession is here valid until 2034, the operator applies already the recommendations from the cantonal water authority by letting a reserved flow of 400 l/s to the water stream. Recently the authority has defined again the reserved flow regarding the seasons. Finally, it will be 600 l/s from July to September and 300 l/s the rest of the year, which represents the same annual amount of water as the current situation. The project is then to use this reserved flow and the gross head between the back water level and the foot of the dam to produce electricity.

As the head varies between 17 and 27 meters, a Kaplan turbine (cf. § 5.3.1 and 5.3.2) with variable speed will be set. The hill chart of the turbine is here an essential tool as it permits to optimise the production by guaranteeing high performance and operation with cavitation erosion for the two discharges and head variations. This project has then two positive impacts: it permits to recover a part of the green electricity production lost by the large power plant while favouring the local ecosystem.

### 3.2.6 On a fish pass system

Fish passes and bypass systems at hydropower plants can cause losses in electricity generation from a few percent to more than 10%. Modern technologies as well as unusual design solutions allow to transform the water energy lost as reserved flow in a new resource available downstream of weirs and dams of existing hydro power plants (Papetti & Frosio, 2010; Rizzi et al, 2010).

To help fish to locate and navigate their way to the fish pass entrance, an additional discharge is necessary at its entrance downstream. The idea is to exploit this discharge and the head in the dam with a small hydro scheme, by arranging for an intake upstream of the dam with a penstock pipe routed parallel to the fish pass, and the turbine discharging near the entrance to the fish pass.

- Case study Aire-La-Ville, Switzerland: The Verbois large hydropower plant (100 MW, 466 GWh/year) is sited on a dam across the river Rhône near Geneva. The maximum head achievable in the dam is 21m. In 1999 a fish pass (cf. Photo 17) was installed (the longest of Switzerland with 350m), comprising 107 pools, supplied by a discharge of 710 l/s. To help fish to locate and navigate their way to the fish pass entrance, an additional discharge of 2 m<sup>3</sup>/s was deemed to be necessary at its entrance downstream all year round. A proposal was made to exploit this discharge and the head in the dam with a small hydro scheme, by arranging for an intake upstream of the dam with a penstock pipe routed parallel to the fish pass, and the Francis turbine (cf. Photo 18) discharging near the entrance to the fish pass. Since 2003, the upstream fish migration has been guaranteed for 26 species, while the production of electricity has been facilitated.



Photo 17. Aire-La-Ville: Verbois fish pass and the SHP.



Photo 18. Aire-La-Ville: the Francis turbine set on the attraction discharge, close to the fish pass entrance.

### 3.2.7 In a navigation lock or dam

Navigation locks and dams cause water level fluctuations. Energy recovery consists then in using the difference of water levels by setting the turbine into the channel, even during the filling and emptying of the locks. As the flood passage capacity has to be maintained, the machine will have either to be set as a bypass of the channel, or to be lifted higher than the upstream flood level.

- Case study L'Ame, France: The Mayenne River is navigable and equipped with 16 locks & dams. The l'Ame project is the second fitted with a very-low-head turbine (Kaplan type) on this river (cf. Photo 19 and Photo 20). A program to equip the 14 remaining locations is being developed.

The main challenge in this case was to fit in 19th century infrastructures with a small visual impact and high fish friendliness due to the presence of silver eels.



Photo 19. L'Ame: downstream global view of the dam and the turbine.



Photo 20. L'Ame: upstream view of the turbine.

During ship locks operation depending on their construction and frequency of passage of the vessels 0.01 to 1% of annual flow volume must be available. This represents a loss in electricity generation if inland navigation is associated with a hydropower plant. To recover this type of energy, a pilot project was installed in a ship lock at Freudenuh hydropower plant in Vienna, Austria (Wedam et al, 1999). The 5 MW capacity module is designed to generate power during both the filling and emptying of lock operation. It is composed of 25 small and identical units of 200 kW each, arranged within a frame in the shape of a matrix (Wedam et al., 2004; Schlemmer et al. 2007). An alternative technology to recover energy lost for ship locks operation has been developed in the US. There is an opportunity to install low head hydro for over 230 locks and dams with auxiliary locks in the U.S (Krouse, 2009).

### 3.2.8 In a desalination plant

Desalination plants use reverse osmosis to separate water from dissolved salts through semi-permeable membranes under high pressures (from 40 to 80 bars).

The residue of liquid water containing salt, still at high pressure can be passed through a turbine in order to recover part of the energy used for the initial compression.



- Case study Tordera, Spain: Tordera desalination plant generates drinking water for Maresme Nord and for La Selva, situated on the North coast near Barcelona. The plant takes sea water from wells, which implies that less water is taken from the aquifer and sea intrusion can be stopped. The reverse osmosis is the process used to separate water from dissolved salts through semi-permeable membranes under high pressures. Here four groups are set (cf. Photo 21 and Photo 22), each one composed of a pump, a motor and a 1-jet Pelton turbine on the same axis. The pumps are used to increase the water pressure (up to 70 bars) so that the water (without salt) can cross the membranes, while the turbines recover the energy from the concentrate outlet of the reverse osmosis, inferring smaller motors. Finally 10 to 20 hm<sup>3</sup> of drinking water are generated per year.



Photo 21. Tordera: the four groups.



Photo 22. Tordera: a dismantled Pelton turbine.

Potentials for development of hydro-powered Red Sea water desalination in Jordan are discussed in Akash & Mohsen (1998). A paper dealing with a global environmental analysis of the integration of renewable energy – wind energy, photovoltaic energy and hydropower – with different desalination technologies is given by Raluy et al. (2005).

### 3.2.9 In a cooling or heating system

Cooling or heating systems can present a pressure difference that can be recovered by hydro turbines. A system designed by Frederiksen et al. (2008) recovers excess pressure from a district heating system to direct-drive the circulation pump within the building (typically rated around 1 kW) and a small generator. This not only maintains the hot water circulation, but also provides enough power to run the electrical control system so that the heating continues to operate even when there is a fault in the electricity network. Wollerstrand et al. (2009) gives a similar case of a small turbine set for energy recovery that can drive (directly or not) the circulation pump. Bansal & Marshalla (2010) investigated the feasibility of recovering lost energy from typical bio-gas upgrading facilities by means of a hydraulic turbine, and presented analysis of different types of hydraulic power recovery turbines.

- Case study Sangüesa, Spain: This hydropower project was part of a scheme to improve the cooling system at the Sangüesa Biomass plant. Condenser cooling needs a back pressure to operate, which necessitates a tower of balance of 10.5 meter high (cf. Photo 23). It can be noted that as the biomass plant and the turbine (cf. Photo 25) operate together, the turbine needs operate in continuous service for around 8'000 hours/year.

- Case study Skawina, Poland: The hydropower plant (HPP) was planned together with the thermal one (ThPP). The ThPP uses cooling water from Laczany Channel that bypasses a 20 km long segment of Vistula River and serves also for navigation purposes. After passing through the cooling system of the ThPP, water is led to the HPP (cf. Photo 24) by two concrete channels. The final portion of these channels is open with side walls used as spillways. The plant is equipped with a single hydraulic unit (Kaplan turbine and generator). After leaving the HPP, water is discharged through a 30 m long tailrace channel to Skawinka river.



Photo 23. Sangüesa: the biomass plant and its tower of 10.5 meters.



Photo 24. Skawina: the powerhouse during turbine overhaul.

## 4. How to start and develop a multipurpose scheme project

### 4.1 Main calculations

Here is a brief reminder on basic calculation. For more details, the reader is referred to the Guide on how to develop a small hydropower project (ESHA et al., 2005).

The electrical output power,  $P$ , of a hydropower plant is defined by:

$$P = \rho \cdot Q \cdot g \cdot H \cdot \eta_c \cdot \eta_t \cdot \eta_e \cdot \eta_{tr} \quad [W]$$

With:	$\rho$	=	specific weight of water $\cong 1000$ [kg/m <sup>3</sup> ]
	$Q$	=	discharge [m <sup>3</sup> /s]
	$g$	=	acceleration due to gravity [m/s <sup>2</sup> ]
	$H$	=	gross head [m]
	$\eta_c$	=	penstock efficiency $\geq 90\%$ at nominal discharge [-]
	$\eta_t$	=	turbine efficiency $88\% \leq \eta_t \leq 94\%$ at nominal discharge [-]
	$\eta_e$	=	generator efficiency $\geq 92\%$ at nominal discharge [-]
	$\eta_{tr}$	=	transformer $\geq 97\%$ [-]

The efficiencies mentioned above correspond to the present state of the art for a scheme that uses optimally the water resource.

Whereas for rivers, the yearly production (kWh/year) can usually be estimated by multiplying the maximal electrical output by 4500 hours/year, it is not possible to define this factor for multipurpose schemes. Regarding the collected case studies, the operation at full load varies between 2200 and 8700 hours/year.

## 4.2 Recommended steps for developing a SHP project

The following Table 3 lists the recommended steps of a SHP project from site identification to commissioning. Due to cost efficiency constraints, it may be reduced for sites which output is lower than 15 kW.

	Steps	Goal
1	Site identification	To define the main site characteristics and specificities and to involve the main entities concerned by the existing infrastructure (cf. § 4.3)
2	Preliminary analysis	To evaluate the technical, environmental and economic (with an accuracy of circa 30 %) feasibility of the project: is it worth going further?
3	Feasibility study	To evaluate the technical, environmental and economic (with an accuracy of circa 25 %) feasibility of the project and define the final solution
4	Implementation project	To achieve the specifications for the whole design of the SHP plant (equipments and civil works), and the final plans with a focus on the water quality and on the integration into the existing infrastructure (cf. § 4.4 and 5.1)
5	Public information	To reduce the risk of future public opposition
6	Public inquiry	To obtain the necessary authorisations peculiar to each country
7	Call for tenders and final design	To achieve a call for tenders to equipment suppliers and civil engineering firms, to propose the award, to achieve the final drawings of the schemes
8	Implementation and commissioning	Turbine manufacturing, civil works, erection on site

Table 3. Recommended steps of a SHP project in an existing infrastructure, for an output higher than 15 kW.

## 4.3 Site identification

As mentioned in the previous table, the first step to start a multipurpose project consists in creating collaboration between the infrastructure owner and SHP specialists and collecting information. Here is a first checklist:

- Definition of the primary function of the existing infrastructure,
- Maps and drawings,
- Head or pressure definition:
  - What is the upstream water level?
  - What is the downstream water level?
  - What are their yearly evolutions?
- Pipes characteristics: length, internal diameter, nominal pressure, roughness, age, state, head losses regarding discharges,
- Hydrology:
  - Are there any flow meters in the water network?
  - Definition of the flow duration curve with daily data, the compilation on 10 years being an optimum (cf. Fig. 4),

- Are there any seasonal variations?
- For water networks: evolution of the inhabitants
- For drinking water networks: sources discharges, number of consumers, consumption data and their evolution,

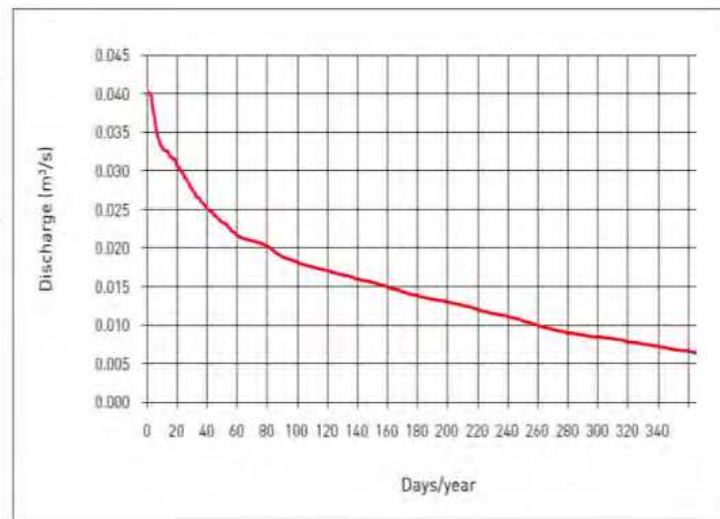

Fig. 4. Example of a flow duration curve.

- Water quality, as defined in section § 5.1
- Evolution of the existing infrastructure (projects? extension?)
- Where could the power house be set?
- Is there a grid close to the existing infrastructure?

Each SHP project is specific to the scheme where it has to be integrated. It is mainly defined by a nominal discharge, a gross head and head losses in the infrastructure as detailed in the Table 4. Then, the yearly average evolutions of the discharges and heads will lead to the production calculation.

Topic	Symbol	Units	Definition
Nominal discharge	Q	m <sup>3</sup> /s	The nominal discharge depends on the flow duration of the site, so as to optimise the production all over the years (cf. Fig. 4).
Gross head	H	m	The gross head is defined by the difference in levels between the upstream water level at the collecting chamber or reservoir or penstock forebay and the downstream water level (at the reservoir, at the treatment plant).
Head losses	Hr	m	Head losses are a loss of energy within the infrastructure (penstock, channels) (cf. § 5.2).

Table 4. Main parameters to define a hydropower site.

#### 4.4 Main requirement: integration to the existing infrastructure

Once the feasibility study has demonstrated the project viability, the implementation project will lead to define the whole design of the SHP plant, with a focus on the integration to the existing infrastructure. In other words, the SHP plant must not impact on the primary function of the site. Table 5 gives a list of basic recommendations.

Infrastructure requirements	Recommended technique
Water quality	The SHP plant must not impact on the water quality, unless it leads to its improvement, while optimising the equipment efficiencies and lifetime (cf. § 5.1).
Discharges at the turbine outlet	The turbine is designed from the flow duration curve of the scheme (cf. figure 3) so as to optimise the production. A bypass is set to reach the infrastructure discharge requirements at any times. Storage is avoided, apart when required for the existing infrastructures (cf. § 5.3.2 and 5.8).
Pressure at the turbine outlet	For heads > 60 meters, if the needed turbine outlet pressure has to be higher than the atmospheric one, the Pelton turbine is at a higher elevation, or a counter pressure Pelton turbine is set (cf. § 5.3.5).
Flexibility	The turbine has high efficiencies for the optimal range of pressure and discharges, defined by the existing scheme (cf. § 5.3.2).

Table 5. Technical recommendations for the integration of the SHP plant into the existing infrastructure.

#### 4.5 Economic aspects specific to multipurpose schemes

The selected case studies show a wide range of investment: from €90,000 to 3,945,000, showing how each multipurpose project is specific. However, a few common principles can be mentioned.

First, the economic calculations distinguish the investments due only to the hydropower plant from the ones due to the primary function of the existing infrastructure. For example, a 100 mm diameter penstock can be sufficient for a water network, but as it may result in high head losses (cf. § 5.2), a 150 mm diameter pipe will be necessary for the hydropower project. Then only the cost difference between both penstocks (supply and setting) will be considered in the economic analysis of the SHP project.

Then, maintenance and operation costs will be reduced with sustainable equipment especially designed for the site. If the generator is connected to the national grid, the selling price will depend on the small-hydropower regulation proper for each country. Finally, by creating a source of income, a hydropower project can be a good opportunity to improve the existing scheme.

### 5. Technical recommendations for SHP plants set in existing infrastructures

The first recommendation, as for any projects, is the design as a whole at an early stage. In addition to this general principle, this section has the objective to list a selection of technical recommendations for multipurpose schemes, with a focus on integration to the existing infrastructures.

#### 5.1 Water quality and its impacts on the scheme design

A SHP plant must not impact on the water quality, unless it leads to its improvement, while optimising the equipment efficiencies and lifetime. Especially while defining the penstock and turbine, attention will be paid on the mechanical resistance and manufacturing easiness of the selected materials but also on their corrosion and abrasive behaviour. Table 6 lists some technical consequences of the water characteristics on the SHP plant design.

Water quality	Recommended technique	Existing infrastructure									
		Drinking water network	Irrigation water network	Raw wastewater network	Treated wastewater network	Runoff collection system	Reserved flow	Fish pass	Navigation lock	Desalination plant	Cooling / heating system
Gravels and stones	Setting of a grid at the forebay	X	X	X		X	X	X	X		
Sand particles	Setting of a de-silted set before the forebay	X	X	X		X	X	X	X		
	Pelton runner built with mounted buckets to unset and replace the buckets										
Drinking water	All parts in contact with water in stainless steel	X									
	Electrical actuators to replace all oil ones	X									
Chlorinated water	Sacrificed anodes to prevent from erosion	(X)		X	X						
Salt	All parts in contact with water in a high quality stainless steel									X	
Organic wastes (bacteria)	Increase of the penstock internal diameter, to limit head losses due to the deposits on the wall created by bacteria			X	X						
Fat	Fat removing system at the forebay			X							
Fibrous and filamentous matter (plants, strings, ...)	Setting of a screening system equipped with a trash rack at the forebay to limit the wastes that enter the penstock and the turbine.		X	X		X			X		
	Suppression of all obstacles where the materials could accumulate. For Pelton turbines, it means no x-cross liner for the nozzles and no deflector.			X							
	Progressive flow speed increase within the turbine, to avoid trash accumulation			X							
	Integration of hand holes in the casing to clean the machine			X							
	For small Kaplan and diagonal turbines, special cleaning programme based on the closure of the downstream valve.		X	X			X		X		
Wastewater	All parts in contact with water in stainless steel			X							

Table 6. Technical recommendations due to water quality on SHP plant design.

It can be noted that the following infrastructures use water which quality is similar to rivers:

- irrigation water network
- reserved flows or compensation ones at the foot of hydropower dams, or of water treatment plants
- fish pass system
- navigation locks and dams

For cooling/heating systems, a priori the water quality does not imply a specific design for the turbine. Nevertheless, its temperature has to be considered.

## 5.2 Penstock and head losses

At the start of a SHP project in an existing infrastructure, a first issue is to define if the existing penstocks and channels are suitable to electricity production, which implies mainly to check their mechanical resistance (nominal pressure for a penstock) and head losses.

In general, head losses are acceptable if at nominal discharge they are lower than 10 % of the difference in levels, or in other words if the penstock efficiency is higher than 90 %. Indeed, this corresponds to the present state of the art for equipment that uses optimally the water resource.

To sum up, head losses in a penstock depend on:

- Its shape: singularities as elbows or forks tend to increase head losses
- Its internal diameter
- Its wall roughness and its evolution due to its degradation or/ and to wall deposits.

It may be recalled here that energy loss due to friction in a penstock can be estimated as being inversely proportional to its diameter to the power of five. For instance, a diameter increase of 20% leads to a head losses decrease of 60%.

When considering a wastewater network, the pressure due to the difference of levels between the forebay and the treatment plant (WWTP) has to be reduced, which tends to select a penstock with a small diameter. Thus this will transport wastewaters while wasting the pressure useless for the treatment process. On the contrary, if the objective is to produce electricity, the pressure has to be maximal where the turbine will be set. Therefore, a penstock with a larger diameter will be selected to minimise head losses.

When dealing with raw or treated wastewaters, a possible deposit of polluting loads on the penstock walls due to organic wastes has to be considered. Observations show that this deposit can easily exceed 1 to 2 mm.

Table 7 presents how important the choice of the penstock diameter is, and points out its clogging impact. Calculations have been achieved using Colebrook formula for an 860 m length penstock, a discharge of 280 l/s and a gross head of 115 m. The results are expressed as the penstock energy efficiency, ratio between the gross and net heads.

Penstock diameter (mm)	Polluting load scale thickness (mm)	Head losses (m)	Penstock energy efficiency (%)
312	0	22.7	80.3
312	2	44.2	61.6
380	0	8.5	92.6
380	2	15.5	86.5

Table 7. Head losses in a penstock regarding its diameter and clogging.

Turbine type	Operation range	Multipurpose schemes									
		Drinking water network	Irrigation network	Raw wastewater network	Treated wastewater network	Runoff collection system	Reserved flows and compensation discharges	Fish bypass system	Navigation locks and dams	Desalination plants	Cooling/heating systems
Pelton	60 –1000 m	X	X	X	X	X				X	
Francis	20 – 100 m	X	X	X	X	X	X	X		X	
Diagonal (Deriaz)	25-100 m	X	X	X	X	X	X	X		X	
Kaplan	1.5 – 30 m	X	X	X	X	X	X	X	X	X	X
Reverse pump	< 30 kW	X	X	X	X	X	X	X	X	X	X

Table 8. The five main types of turbine (see also Photos 25-29).

As shown by the above-mentioned values, a small diameter change (+ 21 %) does not only result in reducing head losses (and thus the production loss), but also in reducing the dependency from the clogging thickness. It can be noted that 312 mm and 380 mm are standard diameters, and that excavation and setting costs will be similar for both variants. Moreover, the energy efficiency of the 380 mm penstock without clogging fulfils the SHP performance requirements.

Finally, as for the whole hydropower area, head losses in pipes or channels have to be considered in the cost efficiency of a multipurpose project. Indeed, only a technical and economic calculation, based on the production gain and the cost difference between the variants, will permit to select the optimal equipment.

## 5.3 Turbines

### 5.3.1 Main types of turbines

The above table 8 presents the five main types of turbines. It shows that they are suitable to all multipurpose schemes (considering that dams and locks higher than 60 meters are rare



for SHP to set a Pelton turbine). Reverse pumps (cf. Photo 26) are often found in drinking and other water networks, when the available output is lower than 30 kW, thanks to their affordable price (Williams, 2003; Williams, 2010, Budris, 2011; García et al., 2010; Steller et al, 2008; Sulzer Pumps, 2011). Another advantage of using pumps within the water industry is that a pump is a familiar piece of equipment, and maintenance requirements are well known (Orchard & Klos, 2009). However, as seen in section § 5.3.2, they are generally not suitable to multipurpose schemes.

IntechOpen



Photo 25. Francis turbine with a spiral casing (case study Sangüesa).



Photo 26. Reverse pump set on the treated wastewater (case study Nyon).



Photo 27. The Diagonal turbine set in Mhyllab's test bench.



Photo 28. Kaplan runner with 8 blades during manufacturing, to be set within a drinking-water network (case study Poggio Cuculo).



Photo 29. The Pelton runner and its 3 jets (case study La Zour).

### 5.3.2 Flexibility and performances

The SHP plant operation must not impact on the primary function of the existing infrastructure. Thus, the turbine has to be as flexible as possible regarding the available pressures and discharges, while guaranteeing high performances on the largest operation ranges (Table 9).

The turbine design is based on the site flow duration curve (cf. Fig. 4), a crucial tool to optimize the production and the viability of the project. Indeed, the discharges can evolve with the spring hydrology and/ or with human activities.

Turbine type	Discharge control device	Minimal discharge
Pelton	One to five adjustable nozzles	At least 15% of the nominal discharge of one nozzle
Francis	Adjustable guide vanes	Circa 50 % of the turbines' nominal discharge
Diagonal and Kaplan	Fixed or adjustable guide vanes, adjustable runner blades	At least 20 % of the turbines' nominal discharge
Reverse pump	No device	85 - 90 % of the machines' nominal discharge

Table 9. The five main turbines and their flexibility.

The case study le Châble-Profray set on raw wastewaters is an interesting example of over-dimensioned project. The first project, in 1993, was based on a nominal discharge of 240 l/s that considered the sudden discharge changes due to storms and snow melting, and also the important population increase due to the winter touristic activities. Therefore, the turbine was only working a few days per year at its nominal discharge. Moreover, during the dry season, the limited available discharge implied to be stored at the forebay to allow electricity production. This storage resulted in an important generation of decanted deposits. An accumulation of grease at the surface was also observed, leading to form a crust that had to be regularly removed. Furthermore, such wastewater storage makes the further treatment

more difficult. Finally, the new turbine was designed for 100 l/s, leading to a production increase of 45% (0.85 GWh/year instead of 0.58 GWh/year), although the nominal discharge is 2.4 times lower.

Some multipurpose schemes deal with steady discharges, as for the following case studies:

- Aire-la-Ville, dealing with an attraction discharge for fish to find the entrance of the upstream migration system,
- Llys y Fran, dealing with a compensation discharge for water treatment schemes

Then, SHP plants at the foot of large hydropower dams generally work with a steady reserved flow. However, the case study Le Day deals with a reserved flow that doubles during the summer season.

For the case study Poggio Cuculo, the turbine works with three different drinking water discharges throughout the year depending on the season and if it is day or night. This variation is due to the price of the electricity consumed by the water treatment plant.

High performances depend on the site definition and on the whole design of the SHP plant. Therefore the project manager is recommended to go through all the analysis steps listed in Table 3 in collaboration with small hydropower specialists, and to ask the suppliers to justify the efficiencies of their equipment.

As shown on Table 9 and Fig. 5, Pelton, Diagonal and Kaplan turbines are especially recommended for their flexibility regarding discharges.

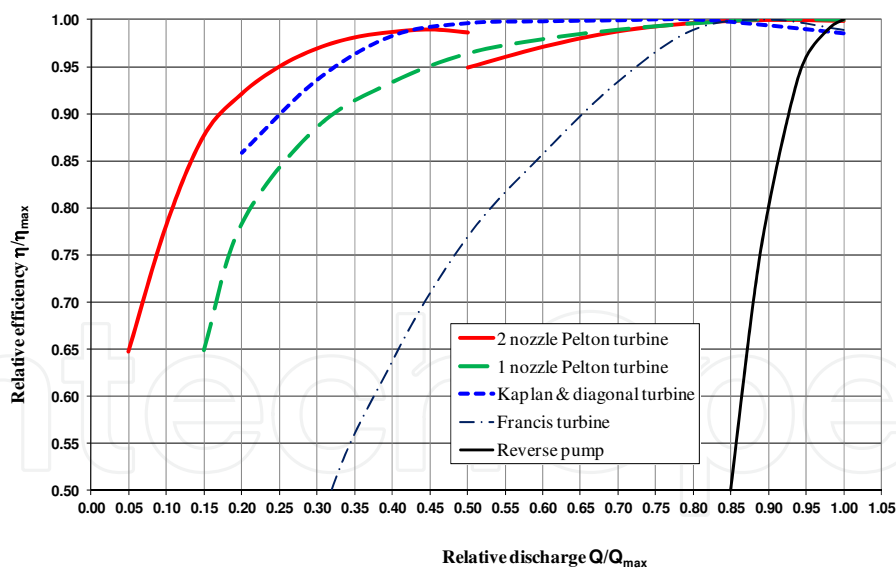

Fig. 5. Relative efficiencies regarding the discharges for Pelton, Diagonal and Kaplan, and Francis turbines, and reverse pump.

On the contrary, a **reverse pump** is not recommended regarding its lack of flexibility due to the absence of a regulation device, leading to:

- a cyclical operation:
  - it infers numerous starts and stops, leading to an untimely wear of the equipment,

- it requires a buffer reservoir designed for at least one operation hour,
- a problematical synchronisation,
- a specific design to operate with high performances as a turbine, which reduces its low investment advantage.

The case study Nyon commissioned in 1993 is composed of a reverse pump (cf. Photo 26) especially designed for the site. As it works with a fixed discharge, the frequent automatic operations to start up and shut down the reverse pump (circa 18 times per 24 hours) require especially sturdy drive systems that are relatively expensive. For example, the upstream butterfly valve has already been changed due to strong cavitation. Moreover, the neighbours complain about the noise and the vibrations due to these operations. Finally the operator has launched a study to replace the reverse pump with a Pelton turbine, with the objective to gain flexibility, reduce noise and vibrations and increase production.

### 5.3.3 Drinking water quality and turbines

To demonstrate that turbines can respect water quality, or in other words that drinking water can pass through the turbine before being consumed, a comparison with pumps can be achieved, as shown in Table 10.

	<b>Pumping station</b>	<b>Turbine station</b>
Inlet valve	yes	yes
<b>Discharge regulation device</b>	<b>no</b>	<b>yes</b>
Runner linked to a rotating shaft	yes	yes
Shaft gaskets	yes	yes
Casing and runner in contact with water	yes	yes
Greased-for-life roller bearings	yes	yes
<b>Electrical machine</b>	<b>yes (engine)</b>	<b>yes (generator)</b>
Electrical panels	yes	yes
Medium voltage / high voltage transformer	Yes, if needed	Yes, if needed
Usual building materials of the hydraulic machine	Cast, black steel, stainless steel, bronze	Cast, black steel, stainless steel, bronze
<b>Automatic by pass</b>	<b>no</b>	<b>yes</b>
Water access	Disassembly necessary	Disassembly necessary

Table 10. Comparison between a pump and a turbine station.

### 5.3.4 Adaptations to raw wastewater

The main difficulty with raw (untreated) wastewaters is linked with fibrous and filamentous residues that are not caught by the forebay grids (vegetal fibres, strings, threads, etc). Such

materials can block on any obstacles in the flow, as for example in the guide vanes of a reaction turbine. Then, some other wastes can cling at them and agglomerate, which can lead to a partial or total clogging of the turbine and of its control systems.

For a **Francis turbine**, the guide vanes and the fixed blades of the runner are obstacles for the wastes. The cleaning of a jammed turbine can imply its whole dismantling, and the replacement of damaged parts, reducing the production of the power plant, and thus, increasing the kWh cost price.

**Diagonal and Kaplan turbines** face the same set of problems. But it is possible to remove some fibrous wastes by closing regularly the downstream security valve, so as to create a wave back.

On the contrary, **Pelton turbine** geometry is ideal for these applications. Indeed, the simplification of the turbine shapes by choosing progressive flow acceleration reduces waste accumulation. Fig. 6 shows the principle of a 4-nozzle Pelton turbine with such a simplified manifold composed of standard pipes, elbows and tees.

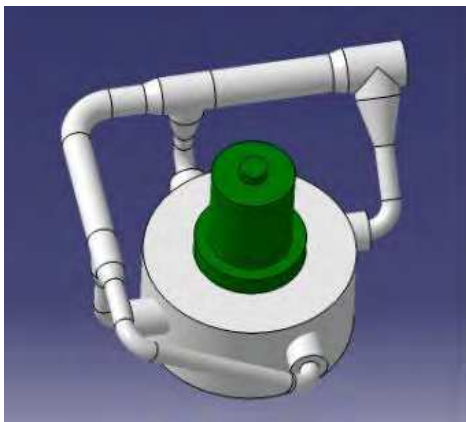

Fig. 6. 4-nozzle Pelton turbine with a progressive flow acceleration to avoid waste accumulation.



Photo 30. The x-cross liner for a nozzle, worn out by limestone.



Photo 31. Achievement of a Pelton runner with mounted buckets (St Jean SHP plant, Switzerland, set in a drinking water network,  $H = 373$  m,  $Q = 34$  l/s,  $P=102$  kW, 2009).



Photo 32. Pelton bucket worn out by sand particles (case study Le Châble-Profray).

Furthermore, it is recommended to avoid:

- the x-cross liners for the nozzles (cf. Photo 30)
- the deflectors (cf. § 5.5), which implies that the turbine and the generator must be able to bear runaway speed for at least the time needed to close the nozzles.

Once these usual design precautions are considered, the only possible clogging risk (but rare) concerns the nozzle tip liner. Finally, compared to a Francis turbine, the cleaning of a Pelton turbine is simple and can be achieved thanks to hand holes to get in the machine without dismantling it.

Regarding wear by abrasion, for **Pelton turbines**, it concerns the needle, the nozzle and, especially, the internal face of the buckets. As far as suitable manufacturing layouts have been achieved, the interchange ability of the needles and the nozzles should not be a problem. On the contrary the replacement and the repair of the buckets are not as simple. One solution is the runner with mounted buckets: the buckets are set together by screwing and pre-stress between two flanges (Photo 31 and 32).

### 5.3.5 Turbine setting

Whereas section § 3 described turbine setting regarding each multipurpose scheme, this section aims at detailing the possible positions of turbine regarding their types.

- **Pelton turbines and counter pressure turbines**

As a Pelton runner operates in the air, at atmospheric pressure, the reservoir which received the turbine outlet will be set high enough from the consumers to guarantee them a sufficient pressure.

When a higher outlet pressure is required for the existing infrastructure, a counter pressure turbine can be set. For this turbine type, the runner rotates in an air volume maintained at the requested downstream pressure (Photo 33).



Photo 33. Counter pressure Pelton turbine (Fällanden SHP plant, Switzerland, set in a drinking water network,  $H = 140$  m,  $Q = 16$  l/s,  $P = 17$  kW, 2008).

- **Diagonal, Kaplan, Francis turbines and cavitation**

Diagonal, Francis and Kaplan turbines can be directly set as a bypass of the pressure breaker or of a valve. Fig. 7 and Photo 34 shows a turbine directly set as a bypass of the initial regulating valve.

However, the setting of diagonal, Francis and Kaplan turbines is limited by cavitation (Cottin et al., 2011). Such phenomenon can appear for any turbine, but especially for Kaplan turbines (Photo 35 and 36). Cavitation is the transformation of liquid water into steam, through a pressure decrease (Franc et al., 2000). The phenomenon is usually noisy, and always fluctuates strongly. The vapour bubble implosion close to the blade is responsible for its erosion, and for the deterioration of the turbine performances. And the erosion will keep on growing, while the production will keep on decreasing.

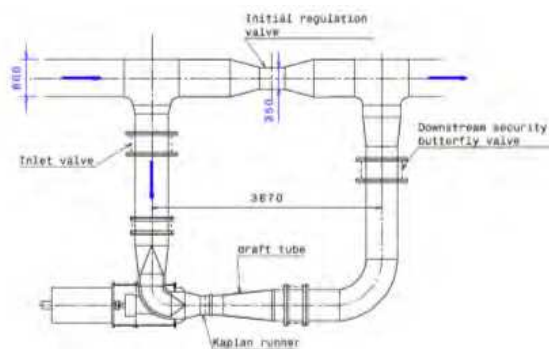

Fig. 7 and Photo 34. Setting of a Kaplan turbine as a bypass of an existing valve in a drinking water network (case study Poggio Cuculo).



Photo 35. Cavitation on blades for a Kaplan runner.



Photo 36. A Kaplan turbine blade, manufactured without hydraulic laboratory techniques, eroded by cavitation after a few months operation.

But cavitation is not a fatality. Laboratory tests permit to identify turbine cavitation behaviour, and to improve it by an appropriate design. Then manufacturers of laboratory-developed turbines can define with accuracy the maximal height regarding the downstream water level at which the runner can be set without cavitation damages.

For the case study Poggio Cuculo, with a head of 28 meters, cavitation could have been a strong constraint. But thanks to the water treatment configuration, the turbine could be set 2 meters under the downstream water level in the reservoir.

#### 5.4 Regulation

Generally, the turbine is regulated according to the upstream water level in the forebay tank, in order to keep it steady.

- When the upstream level tends to rise, the turbine opens up to increase its discharge up to the nominal one. If the upstream level keeps on rising, the surplus can pass through the by-pass.
- When the upstream level tends to go down, the turbine closes itself to take less discharge. If the upstream level keeps on going down, the turbine is shut down.

By controlling the needle stroke for Pelton turbines, the vanes or blades opening for Francis, Diagonal and Kaplan turbines, the turbine can turn to be an efficient and convenient device to regulate discharges.

#### 5.5 Security system

In case of load rejection (due to a storm for example) resulting in disconnection of the turbine from the grid, the machine has to stop automatically. Such shut down must be achieved so as to limit water hammer in the penstock and avoid runaway speed. Indeed, these phenomena could lead to important equipment damage.

The first requirement is that the SHP plant has to be equipped with an emergency power supply. The second depends on the type of turbines.

**Francis turbine** shut down is achieved by closing the guide vanes and the upstream valve with adapted speeds.



Photo 37. A deflector before the commissioning (case study le Châble Profray).



Photo 38. A deflector in the raw wastewater (case study le Châble Profray).



**Kaplan or Diagonal turbine** shut down is achieved by closing the adjustable guide vanes, the runner blades and the downstream valve with adapted speeds.

**Reverse pump** shut down is achieved by closing the upstream or downstream valve with adapted speeds.

For **Pelton turbines**, deflectors are a simple and secure solution. Nevertheless, they are not recommended for raw wastewater, as they may be clogged by wastes. In such cases, the turbine will be designed to resist runaway speed, and a special monitoring will be achieved to regulate the valves closures (Photos 37 and 38).

### 5.6 Maintenance

The maintenance and its cost depend on the water quality and on how the whole design of the SHP plant has been adapted to it, as described in Table 5.

For **drinking water networks**, the maintenance is limited, whereas it can be important for non-adapted SHP plants using **raw wastewater**. To make this maintenance easier, the machine design will integrate hand holes for a direct access to wastes.

It can be noted that most of time, the wastewater treatment plant staff will be in charge of the maintenance.

For the case study Le Châble Profray, in operation since 1993 on raw wastewater, the average usual maintenance amounts to about 40 hours per year. The interventions are linked to the electrical output. Indeed, when the output is lower than the foreseen one for the available discharge, it means that the waste accumulation is not acceptable anymore and the turbine has to be cleaned.

### 5.7 Bypass

A bypass of the turbine may be required to guarantee the primary function of the existing infrastructure at any time. For water networks for example, it has to be systematically set. It can be used when the turbine is not operating due, for example, to a too low discharge or to maintenance needs. It can also be used when the discharge needed for the existing scheme is higher than the turbine nominal one. In such situation, the turbine uses its maximal discharge, whereas the surplus flows through the bypass (if the head losses are still acceptable for the turbine).

As it replaces the turbine, the bypass has different functions: to regulate the discharges and/or the water levels, to reduce the pressure.

Different instruments exist for pressure reduction in a pipe. They have to be suitable for a continuous operation, and automatically and manually controllable.

For high heads, a Carnot pressure breaker may be the best tool (cf. Fig. 8). It is composed of an adjustable nozzle placed into a long tube immersed in a reservoir. Such device permits to maintain the upstream water level, to regulate the bypassed discharge, while wasting the excess pressure. The nozzle control system is integrated in the process control system of the existing infrastructure and the SHP plant.

When the SHP plant is equipped with a single jet Pelton turbine, the Carnot pressure breaker can be equipped with a similar nozzle, leading to regulation simplification and cost reduction.

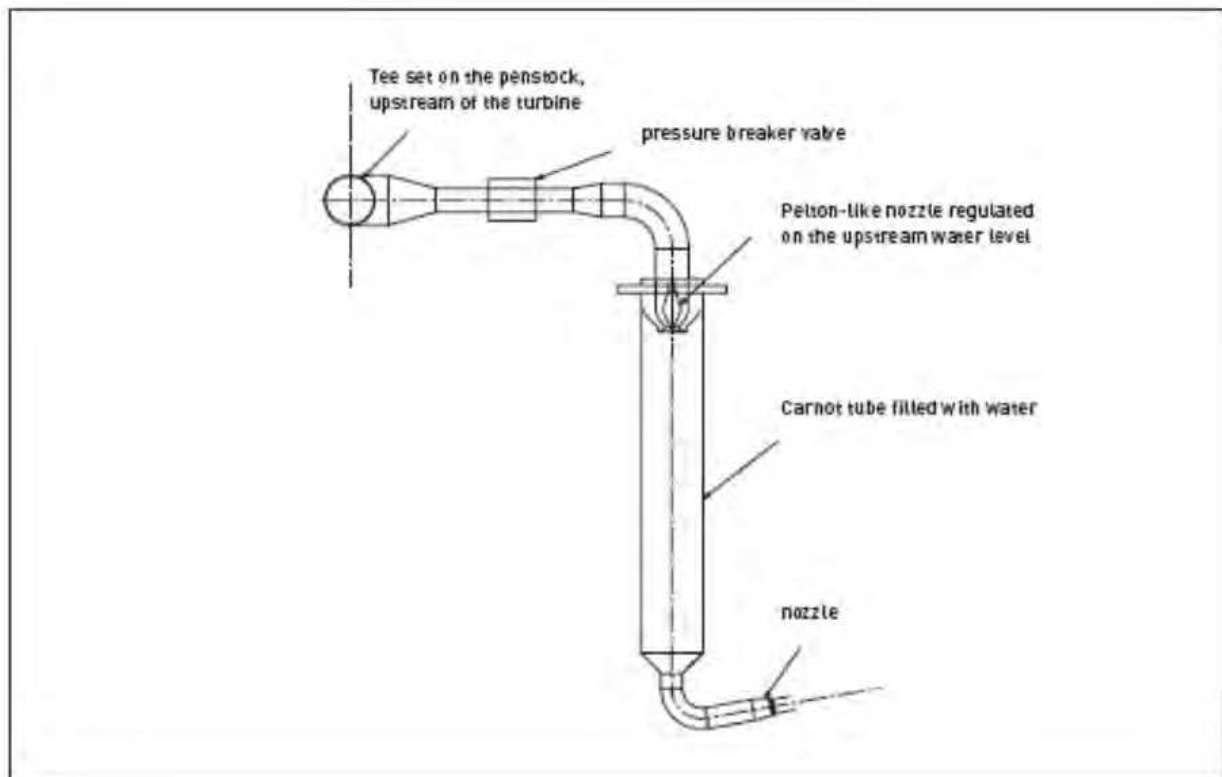

Fig. 8. Carnot pressure breaker.

## 6. Conclusions

The equipment used for multipurpose schemes does not differ much from the traditional ones used for water streams, apart from the specific conditions of each infrastructure that have to be considered all along the projects' steps.

Regarding environment, as the hydropower plant has to be integrated to the existing infrastructure, the impacts are mainly due to its primary function. One can even mention that the environmental impact is positive as the SHP plant implies an energy recovery.

However multipurpose schemes development is just at the beginning. This is mainly due to the **lack of information** on the possibility to recover energy. Moreover, in some countries, one second obstacle would be **the lack of administrative procedures** adapted to SHP. On the contrary, the procedure in Switzerland is simple. The water network is generally owned by the water office of the commune or city that will often be the plant operator, while the project has to be announced to the authority dealing with the sanitary field.

Small hydropower plants integrated into existing infrastructures is thus a promising environment-friendly market to develop.

## 7. Acknowledgements

This paper is based on the findings of the EU partially funded projects, Small Hydro Action for the Promotion of efficient solutions (SHAPES; 2007-2010; No TREN/07/FP6EN/S07.74894/038539) and Stream Map for Small Hydropower in the EU (SHP STREAMMAP; 2009-2012; No IEE/08/697/ SI2.52932), for which the coordinator was the European Small Hydropower Association (ESHA). The authors would like to thank Pamela Blome (Wasser Tirol, Austria), Raymond Chenal (Mhylab, Switzerland), Cédric Cottin (Mhylab, Switzerland), Jonathan Cox (Dulas, United Kingdom), Pierre-André Gard (Services Industriels de Bagnes, Switzerland), Jean-Bernard Gay (Mhylab, Switzerland), Marc Leclerc (MJ2 Technologies, France), Tony Leggett, Carmen Llansana Arnalot (Acciona, Spain), Jean Nydegger, Luigi Papetti (Studio Frosio, Italy), Prof. Bernhard Pelikan (BOKU, Austria; ESHA), Siegfried Ploner (Wasser Tirol, Austria), Bruno Reul (Mhylab), dr. Janusz Steller (IMP PAN, Poland), Francisco de Vicente (Acciona Energy, Spain), Andreas Walner (Wasser Tirol, Austria). The authors would like also to thank the reviewers for their valuable comments.

## 8. Illustrations copyright

Acciona Agua, Tordera: case study Tordera  
 Acciona Energy, Pamplona, Spain: case study Sangüesa  
 Blue Water Power, Schafisheim, Switzerland: Photo 33  
 Betriebsgesellschaft Marchfeldkanal, Austria: case study Marchfeldkanal  
 Commune de Savièse, Savièse, Switzerland: case study La Zour  
 Dulas, Wales, United Kingdom: case studies Llys y Fran  
 France Hydro Electricité: case study L'Ame  
 Gasa SA, Lausanne, Switzerland: case study La Zour, le Châble-Profray  
 IKB, Innsbruck, Austria: case study Mülhau  
 IMP PAN, Gdansk, Poland: case study Skawina  
 MHyLab, Montcherand, Switzerland: Photo 11, Photo 12, Photo 13, Photo 14, Photo 27, Photo 31, Fig. 5, Fig. 6, Fig. 7, Fig. 8, case studies Poggio Cuculo, Armary, Le Châble-Profray, Seefeld, Nyon, Le Day  
 MJ2 Technologies, Millau, France: case study L'Ame  
 Nuove Aquae, Arezzo, Italy: case study Poggio Cuculo  
 Services Industriels de Bagnes, Bagnes, Switzerland: case study Le Châble-Profray  
 Services Industriels de Genève, SIG, Geneva, Switzerland: case study Aire-La-Ville  
 Shema, France: case study L'Ame  
 Stanislaw Lewandoski & Emil Ostajewski, Poland: case study Skawina  
 Studio Frosio, Brescia, Italy: case study Rino  
 Wasser Tirol, Innsbruck, Austria: case studies Mülhau, Seefeld

## 9. References

Akash, B.A. & Mohsen, M.S. (1998). Potentials for Development of Hydro-Powered Water Desalination in Jordan. *Renewable Energy*, Vol. 13, No. 4, pp. 537-542, ISSN 0960-1481, 1998

- Bansal, P. & Marshalla, N. (2010). Feasibility of Hydraulic Power Recovery from Waste Energy in Bio-Gas Scrubbing Processes. *Applied Energy*. Vol. 87, Issue 3, pp. 1048-105, ISSN: 0306-2619, March 2010
- Bischoff, V. & Salamin, J. (2010). Combining Drinking Water Supply of Two Municipalities to Generate more than 1.4 MW. *Proceedings of the International Conference HIDROENERGIA 2010*, Lausanne, Switzerland, June 16-19, 2010.
- Bodin, M. (2008). U.S. Looks to Rediscover Hydropower as Untapped Energy Source. In: *Popular Mechanics*, 29.08.2011, Available from <http://www.popularmechanics.com/science/energy/hydropower-geothermal/4281705>
- Boillat, J.L; Bieri, M. & Dubois J. (2010). Economic Evaluation of Turbining Potential in Drinking Water Supply Networks. *Proceedings of the International Conference HIDROENERGIA 2010*, p.8, Lausanne, Switzerland, June 16-19, 2010.
- Budris, A.R. (2011). Using Pumps as Power Recovery Turbines. In: *Water World*, 29.08.2011, Available from <http://www.waterworld.com/index/display/article-display/366823/articles/waterworld/volume-25/issue-8/departments/pump-tips-techniques/using-pumps-as-power-recovery-turbines.html>
- Chenal, R.; Vuillerat, C.A. & Roduit, J. (1994). *L'eau usée génératrice d'électricité. : concept, réalisation, potential*. Office Fédéral de l'Energie, p.75, Berne (English and French)
- Chenal, R.; Choulot, A.; Denis, V. & Tissot N. (2009). Small Hydropower. In: *Renewable Energy Technologies*, Section 8, Ed. Sabonnadière C., ISBN: 978-1-84821-135-3, Iste, Wiley
- Cottin, C.; Reul, B. & Choulot, A. (2011). Laboratory results of the DIAGONAL project: a step towards an optimal small hydro turbine for medium head sites (25-100 m), *Proceedings of the International Conference HYDRO 2011*, Prague, Czech Republic, October 17-19, 2011.
- Denis, V. (2007). Wastewater Turbining Before and After Treatment: the Example of Amman City - Hashemite Kingdom of Jordan. *Proceedings of the International Conference "Hydro 2007"*. p.9, Granada, Spain, October 15-17, 2007
- Denis, V. (2008). Wastewater Turbining Before and After Treatment. An optimal use of existing infrastructures. *Proceedings of the International Conference HIDROENERGIA 2008*, p.10, Bled, Slovenia, June 12-13, 2008.
- European Small Hydropower Association [ESHA], Ademe; Mhylab; ISET;EPFL; LCH; IT power; Austrian Small Hydropower Association; SCTPH; SERO; Studio Frosio. (2005). Guide on How to Develop a Small Hydropower Plant. Thematic Network on Small Hydropower. In: *The European Small Hydropower Association*. 29.08.2011, Available from <http://www.esha.be/>
- ESHA ;Mhylab; Acciona Energy;Dulas; IMP PAN;IWHW; Studio Frosio; WMF; Wasser Tirol (2010). Energy Recovery in Existing Infrastructures with Small Hydropower Plants. Multipurpose Schemes - Overview and Examples. FP6, SHAPES, p. 53. In: *The European Small Hydropower Association*. 29.08.2011, Available from <http://www.esha.be/>

- Franc, J.P.; Avellan, F.; Karimi, A.; Michel, J.M.; Billard, J.Y.; Briançon-Marjollet, L.; Fréchou, D.; Fruman, D.H.; Kueny, J.L. (2000). *La Cavitation, Mécanismes physiques et aspects industriels*, p. 582, ISBN978 2 868834515. Collection Grenoble Sciences (in French).
- Frederiksen, S.; Wollerstrand, J. & Ljunggren, P. (2008). Un-interrupted District Heating Supply in the Event of an Electric Power Failure. *The 11th International Symposium on District Heating and Cooling*, Reykjavik, Iceland, August 31 - September 2, 2008.
- García, J.P., Marco, A.C & Santos, SN. (2010). Use of Centrifugal Pumps Operating as Turbines for Energy Recovery in Water Distribution Networks. Two Case Studies. *Advanced Materials Research*, Vol.107, No.87. pp.87-92, ISSN: 1022-6680, 2010
- Giacopelli, P. & Mazzoleni S. (2009). Lonato SHPP: a successful exploitation of an existing head on an irrigation canal in northern Italy pp.4. *Proceedings of the International Conference HYDRO 2009*, Lyon, France, October 26-28, 2009.
- Hahn, C. (2009). Vienna Wastewater Treatment Plant Receives SHP Unit. *Aqua press international*. No1. pp.40-41. (In German and English)
- Krasteva, M. (2010). Blagoevgradska Bistritsa: Public-Private Partnership for Turbining of Drinking Water. *Proceedings of the International Conference HIDROENERGIA 2010*, p.8, Lausanne, Switzerland, June 16-19, 2010.
- Krouse, W. (2009) Putting Hydrokinetic Power to Work for You. *Proceedings of the Small Hydro Conference 2009*, p.27, Vancouver, Canada, April 28-29, 2009
- Low Impact Hydropower Institute (LIHI) (2009). LIHI Certificate No 43. Deer Island Hydropower Project. Deer Island Wastewater Treatment Plant, Boston Harbor Boston, Massachusetts. In: *The Low Impact Hydropower Institute*, 29.08.2011, Available from <http://www.lowimpacthydro.org/lihi-certificate-43-deer-island-hydropower-project-deer-island-wastewater-treatment-plant-boston-harbor-boston-massachusetts.html>
- Orchard, B. & Klos S. (2009). Pumps as Turbines for Water Industry, *World Pumps*, Elsevier, Volume 2009, Issue 8, pp. 22-23, ISSN 0262-1762, August 2009
- Papetti, L. & Frosio, G. (2010). Use of Reserved Flow for Hydro Production: Recent Achievements. *16th International seminar on hydropower plants. Reliable Hydropower for a Safe and Sustainable Power Production*, p.6, University of Technology, Vienna, Austria, November 24-26, 2010
- Patel, S. (2010). Australia Gets Hydropower from Wastewater. In: *Power*, July 1, 2010, 29.08.2011, Available from [http://www.powermag.com/renewables/hydro/Australia-Gets-Hydropower-from-Wastewater\\_2789.html](http://www.powermag.com/renewables/hydro/Australia-Gets-Hydropower-from-Wastewater_2789.html)
- Pelikan, B. (2005). SHP Engineering: a New Approach and a Key for the Future. *The International Journal on Hydropower & Dams*, 2005, 12(3), pp.57-60, ISSN1352-2523
- Raluy, R.G.; Serra, L. & Uche, J. (2005). Life Cycle Assessment of Desalination Technologies Integrated with Renewable Energies. *Desalination*, 183, pp.81-93. ISSN 0011-9164

- Ramos, H.M.; Mello, M. & De, P.K. (2010) Clean Power in Water Supply Systems as a Sustainable Solution: from Planning to Practical Implementation. *Water Science & Technology: Water Supply – WSTWS*. Vol.10. No1, pp. 39-49. ISSN 1606-9749, 2010
- Rizzi, S.; Papetti, L. & Frosio, G. (2010). Chievo Small Hydro Plant - from the Obligation of Environmental Flow to the Opportunity of Renewable Energy Production. *Proceedings of the International Conference HYDRO 2010*, p.5 Lisbon, Portugal, September 27-29, 2010
- Schlemmer, E.; Ramsauer, F.; Cui, X. & Binder, A. (2007). HYDROMATRIX® and StrafloMatrix. Electric Energy from Low Head Hydro Potential. *International Conference on Clean Electrical Power, ICCEP '07*, pp. 329 - 334, ISBN: 1-4244-0632-3, May 21-23, 2007.
- Steller, J.; Adamkowski, A.; Stankiewicz, Z.; Lojek, A.; Rduch, J. & Zarzycki, M. (2008). Pumps as Turbines for Hydraulic Energy Recovery and Small Hydropower Purposes in Poland. *Proceedings of the International Conference HIDROENERGIA*, p. 10, Bled, Slovenia, June 12-13, 2008.
- Sulzer Pumps (2011). Reducing Pressure - Increasing Efficiency. Sulzer Technical Review. No 1. pp. 26-29
- Swiss Federal Office of Energy [SFOE]. (1995). *L'eau usée génératrice d'électricité, Dossier technique et étude du potentiel*, Diane 10, Petites centrales hydrauliques, 1995. In: Swiss Federal Office of Energy, 29.08.2011, Available from <http://www.bfe.admin.ch/kleinwasserkraft/03834/04171/index.html?lang=en> (only in French).
- Swiss Federal Office of Energy [SFOE]. (1996). Small Hydropower Programme *Trinkwasserkraftwerke, Technische Anlagendokumentation / Petites centrales hydrauliques sur l'eau potable, Documentation technique*, Diane 10, Petites centrales hydrauliques (only in French and German). In: Swiss Federal Office of Energy, 29.08.2011, Available from <http://www.bfe.admin.ch/kleinwasserkraft/03834/04171/index.html?lang=en>
- Toader, S; Praisach, Z. & Pop, F. (2010) Energy Recovery System on Drinking Water Pipe at Cluj-Napoca, Romania. *Proceedings of the International Conference HIDROENERGIA 2010*, p.8, Lausanne, Switzerland, June 16-19, 2010.
- Wedam, G.M; Materazzi-Wagner, C. & Winkler S. (1999). Implementation of a Matrix Turbine at Freudenua Ship Lock. *Proceedings of the International Conference Hydropower into the next century-III* pp.117-124, ISBN 0952264293. Gmunden, Austria, October 18-20, 1999.
- Wedam, G.M.; Kellner, R. & Braunshofer R. (2004). Innovative Hydropower Development in an Urban Environment. *19th World Energy Congress. Congress Papers*. 19p. Sydney, Australia, September 5-9, 2004
- White, J. (2011). Recovering energy from an existing conduit. *International Water Power & Dam Construction*. pp.18-20, 0306-400X. May, 2011
- Williams A. (2003). Pumps as Turbines – A User's Guide. ITDG Publishing, London, 2nd Edition, ISBN 9781853395673, 2003.

- Williams, A. (2010) Centrifugal Pumps as Turbines: A Review of Technology and Applications. *Proceedings of the International Conference HIDROENERGIA 2010*, p.6, Lausanne, Switzerland, June 16-19, 2010.
- Wollerstrand, J.; Lauenburg, P. & Frederiksen, S. (2009). *A Turbine-Driven Circulation Pump in a District Heating Substation. Conference proceedings ECOS 2009, 22<sup>nd</sup> International Conference on Efficiency, Cost, Optimization, Simulation and Environmental Impact of Energy Systems*, p.9, Foz do Iguaçu, Paraná, Brazil, August 31 - September 3, 2009.

IntechOpen

IntechOpen

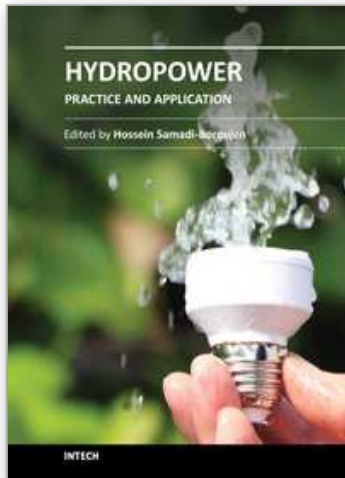

## **Hydropower - Practice and Application**

Edited by Dr. Hossein Samadi-Boroujeni

ISBN 978-953-51-0164-2

Hard cover, 320 pages

**Publisher** InTech

**Published online** 09, March, 2012

**Published in print edition** March, 2012

Hydroelectric energy is the most widely used form of renewable energy, accounting for 16 percent of global electricity consumption. This book is primarily based on theoretical and applied results obtained by the authors during a long time of practice devoted to problems in the design and operation of a significant number of hydroelectric power plants in different countries. It was preferred to edit this book with the intention that it may partly serve as a supplementary textbook for students on hydropower plants. The subjects being mentioned comprise all the main components of a hydro power plant, from the upstream end, with the basin for water intake, to the downstream end of the water flow outlet.

### **How to reference**

In order to correctly reference this scholarly work, feel free to copy and paste the following:

Aline Choulot Vincent Denis, and Petras Punys (2012). Integration of Small Hydro Turbines into Existing Water Infrastructures, *Hydropower - Practice and Application*, Dr. Hossein Samadi-Boroujeni (Ed.), ISBN: 978-953-51-0164-2, InTech, Available from: <http://www.intechopen.com/books/hydropower-practice-and-application/integration-of-small-turbines-into-water-infrastructure>

# **INTECH**

open science | open minds

### **InTech Europe**

University Campus STeP Ri  
Slavka Krautzeka 83/A  
51000 Rijeka, Croatia  
Phone: +385 (51) 770 447  
Fax: +385 (51) 686 166  
[www.intechopen.com](http://www.intechopen.com)

### **InTech China**

Unit 405, Office Block, Hotel Equatorial Shanghai  
No.65, Yan An Road (West), Shanghai, 200040, China  
中国上海市延安西路65号上海国际贵都大饭店办公楼405单元  
Phone: +86-21-62489820  
Fax: +86-21-62489821



© 2012 The Author(s). Licensee IntechOpen. This is an open access article distributed under the terms of the [Creative Commons Attribution 3.0 License](#), which permits unrestricted use, distribution, and reproduction in any medium, provided the original work is properly cited.

IntechOpen

IntechOpen