

We are IntechOpen, the world's leading publisher of Open Access books Built by scientists, for scientists

4,800

Open access books available

122,000

International authors and editors

135M

Downloads

Our authors are among the

154

Countries delivered to

TOP 1%

most cited scientists

12.2%

Contributors from top 500 universities



WEB OF SCIENCE™

Selection of our books indexed in the Book Citation Index
in Web of Science™ Core Collection (BKCI)

Interested in publishing with us?
Contact book.department@intechopen.com

Numbers displayed above are based on latest data collected.
For more information visit www.intechopen.com



Thermal Design of Cooling and Dehumidifying Coils

M. Khamis Mansour and M. Hassab
*Mechanical Engineering Department, Faculty of Engineering,
Beirut Arab University,
Lebanon*

1. Introduction

The cooling and dehumidifying coil is a critical component of air conditioning. Its performance has a strong bearing on the ultimate indoor environmental conditions, which in turn, has a significant impact on the indoor air quality. Decisions made to select a cooling coil influence the initial investment as well as the costs of installing, providing, and maintaining thermal comfort. The efficient thermal design of the cooling coil leads to a crucial reduction in the coil surface heat transfer area and of course, its capital cost and its weight. On the other hand, the enhancement in the coil thermal performance will usually be established at expense of the hydraulic performance of the cooling coil and in turn, its running cost. Because the cooling coil is an integral part of the air distribution system, its geometry – size, number of rows, fin spacing, and fin profile – contributes to the airside pressure drop and affects the sound power level of the fans. (Fan power needed to circulate air through the duct system may warrant extra sound attenuation at the air handler.) Cooling coils are an integral part of the chilled water system or the refrigeration unit, too. The extent to which coils raise the chilled water temperature or the evaporation temperature dramatically affects both capital investment in the cooling coil or the pumping power. Coil performance can even influence the efficiency of the chiller or Dx-unit. The focus of this chapter is on the description of the methodology should be used in thermal design of the cooling coil either chilled water coil or Dx-coil.

Methods to design the cooling and dehumidifying coil either chilled water coil or Dx evaporator coil are usually based on log mean enthalpy or log equivalent dry-bulb temperature difference [1]. In both methods, the cooling coil is treated as a single zone/region and hence the required surface area is determined [2]. This manner of the cooling coil design could lead to an imprecise design particularly when the cooling coil is partially wet. In this chapter, the numerical calculation using a discrete technique "row-by-row method" will be presented to calculate the detailed design of the cooling coil in order to enhance the calculation accuracy and trace the air and coil surface temperature locally.

2. Types of cooling coils

Cooling coils are classified to direct-expansion (DX) coils and chilled water coils as shown in Figure 1. Some coil manufacturers fabricate coils from 5/8 inch OD copper tubes, others

from 1/2 inch copper tube and still others use 3/8 inch tubes. Selection of the tube size is a matter of manufacturer's choice and market demand. Price, as always, plays a major part in the tube size selection.



Fig. 1. Description of the cooling coil for a)- Dx-cooling; b)- Chilled water coil (Aerofin heat transfer products).

3. Coil construction and geometry

In a coil, copper tubes are arranged parallel to one another, either in staggered pattern or non-staggered pattern, along the length L of the coil. A staggered pattern is more commonly used. For 5/8 inch tubes, the triangular pitch is 1.75 inch or 1.5 inch. For 1/2 inch tubes it is 1.25 inch. Plate or ripple fins are used to enhance the heat transfer area. Thus the primary surface area (outside area of bare copper tubes) is enhanced greatly by adding a secondary area of fins. The total area including fins is called outside surface area. The cross-section ($L \times H$) which the air flows is called the face area or the finned area. Thus L is finned length and H is fin height (see Figure 2). Fins are arranged perpendicular to the tubes. Where, the fin spacing varies between 8 and 16 fins per inch of tube.

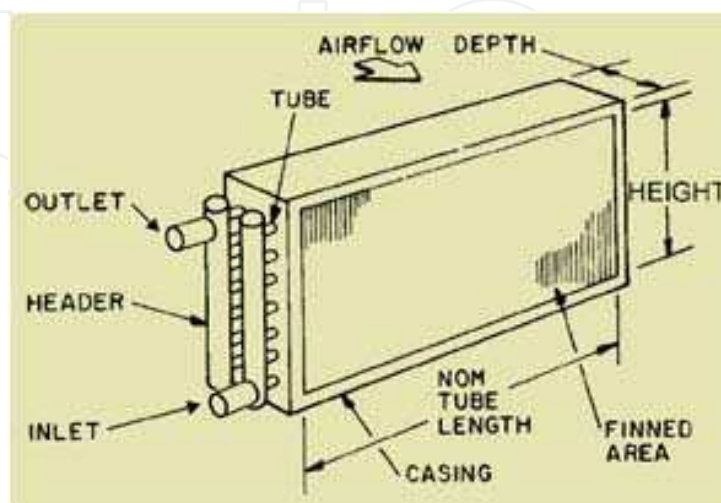

Fig. 2. Geometry configuration of the cooling coil (Aerofin heat transfer products).

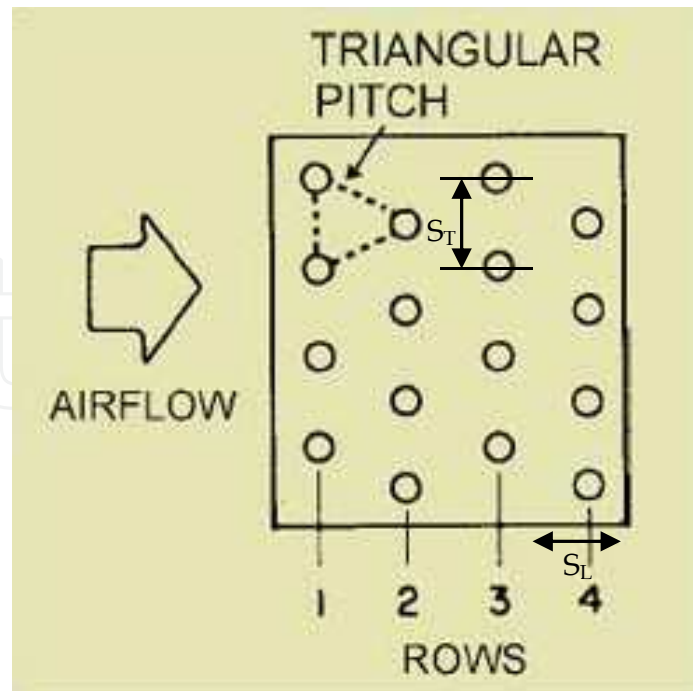

Fig. 3. A 4-row coil with a 4-tube face.

The average air velocity across the face area is called the coil face/frontal velocity and it is calculated as follows [3]:

$$\text{Face Velocity (m/s)} = \frac{\text{Air flow rate (kg/s)}}{\text{Face area (m}^2\text{)}}$$

The number of rows of tubes in the direction of air flow is termed as depth of coil (rows deep, D). Coils with 3, 4, 6 or 8 rows are commonly used. Refrigerant or chilled water enters the first row and leaves the coil from the last row. A coil in which chilled water or refrigerant is supplied to all the tubes in the first row (also referred to as tubes high or tubes in face) is called a maximum or full circuit coil (see Figure 3). Thus a typical coil of 17.5 inch (0.44 m) height which has 10 tubes in face (based on 1.75 inch (0.044 m) pitch) will have a maximum of 10 circuits. If the supply is given to alternate tubes in face, we get a half-circuit coil with 5 circuits as against 10 circuits. The U-bends at the end of the tubes can be arranged, at the time of manufacturing, to obtain the number of circuits desired. See Figure 4 for full and half circuit coils with 4 tube face.

Face velocity is restricted to 500 fpm (2.5 m/s) to avoid carryover of condensate from the coil. The value of 500 fpm (2.5 m/s) is very commonly used for coil sizing and it works very well for cfm/ton in the range of 500 to 600 (2.5 to 3 m³/s per ton). If cfm/ton ratio falls below 500 (2.5 m³/s per ton), this generally happens when room sensible heat factor goes below 0.8 due to high room latent load, a 4-row coil at 500 fpm (2.5 m/s) becomes inadequate. A 5-row coil is not very common. Hence by lowering face velocity, a 4-row deep coil can be selected at 400 fpm (2 m/s), when cfm/ton is about 400 (2 m³/s per ton).. As cfm/ton ratio reduces further, 6-row or 8-row coils have to be selected. This situation is encountered when the occupancy and/or fresh air components are high.

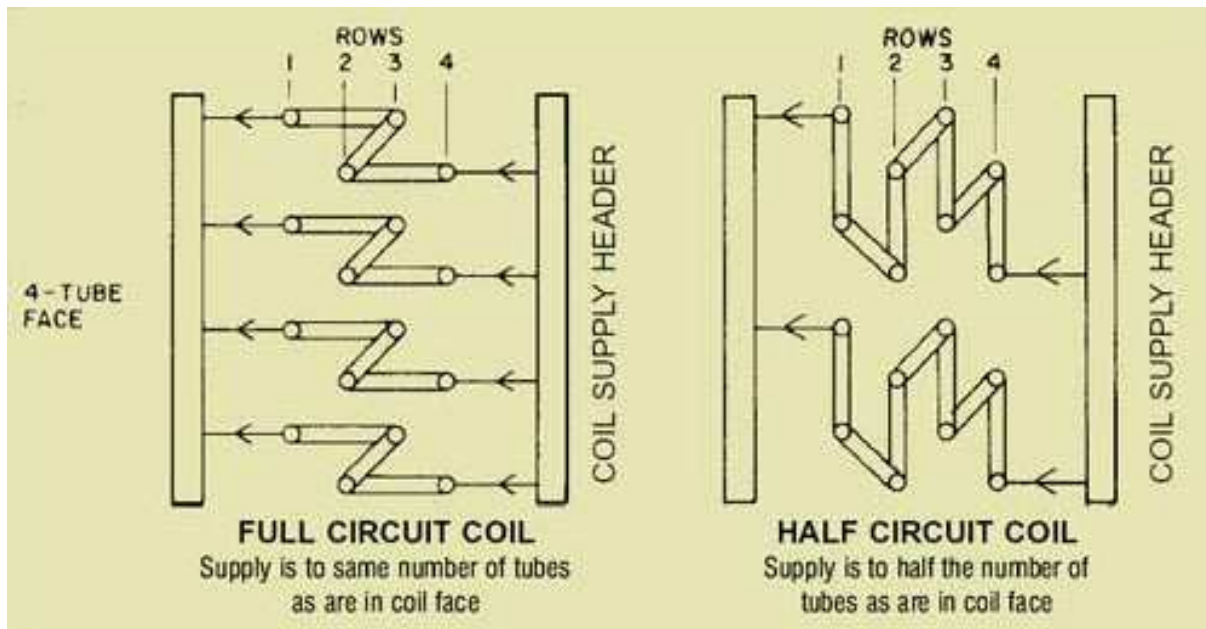

Fig. 4. Full circuit and half circuit four row coils with 4-tube face.

3.1 Fin patterns

There are three standard plate fin patterns that are usually used in the cooling coil: flat-plate, wavy-plate, and star-plate fin patterns, as shown in Figure 5. They are made of Aluminum, copper, and stainless steel or carbon steel. The fins are permanently attached to the tubes by expansion of each tube. Full fin collars allow for both precise fin spacing and maximum fin-to-tube contact. The flat-plate fin type has no corrugation, which results in the lowest possible air friction drop and lowest fan horsepower demands while the wavy-plate fin corrugation across the fin provides the maximum heat transfer for a given surface area, and is the standard fin configuration used. The star-plate fin pattern corrugation around the tubes provides lower air friction. This pattern is used when lower air friction is desired without a large decrease in heat transfer capacity.

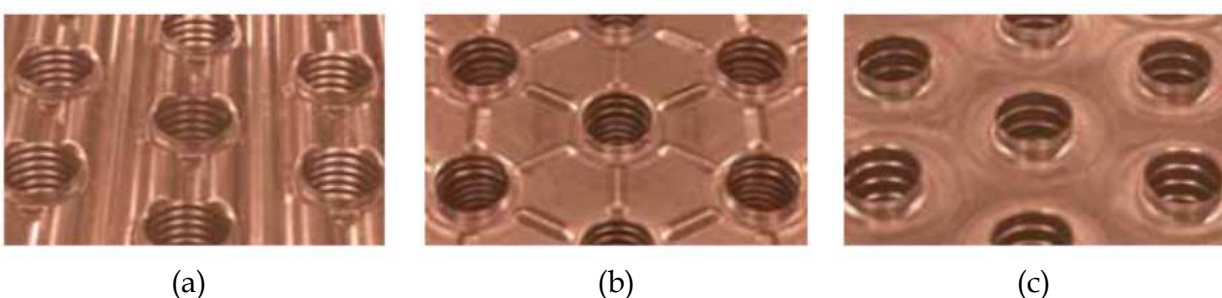

Fig. 5. (a) Wavy-plate fin; (b) Star-plate fin; (c) Flat-plate fin (*Aerofin heat transfer products*).

4. Simultaneous heat and mass transfer in cooling and dehumidifying coils

In the cooling coil, the coolant fluid “chilled water or refrigerant” flows inside the tubes and the air passes across the tube bundle. Since the coolant fluid temperature is less than the dew point temperature to ensure the dehumidification process there is possibility of heat

and moisture transfer between them. The directions of heat and moisture transfer depend upon the temperature and vapor pressure differences between air and wetted surface. As a result, the direction of the total heat transfer rate, which is a sum of sensible heat transfer and latent heat transfers. The concept of enthalpy potential [4] is very useful in quantifying the total heat transfer in these processes and its direction.

The sensible (Q_S) and latent (Q_L) heat transfer rates are given by:

$$Q_S = h_o A_S (t_i - t_a)$$

$$Q_L = h_{\text{mass}} A_S (W_i - W_a) h_{\text{fg}}$$

the total heat transfer Q_T is given by:

$$Q_T = Q_S + Q_L = h_o A_S (t_i - t_a) + h_{\text{mass}} A_S (W_i - W_a) h_{\text{fg}}$$

Where:

t_a = dry-bulb temperature of air, °C

t_i = temperature of water/wetted surface, °C

W_a = humidity ratio of air, kg/kg

W_i = humidity ratio of saturated air at t_i , kg/kg

h_o = convective heat transfer coefficient, W/m².°C

h_{mass} = convective mass transfer coefficient, kg/m²

h_{fg} = latent heat of vaporization, J/kg

Since the transport mechanism that controls the convective heat transfer between air and water also controls the moisture transfer between air and water, there exists a relation between heat and mass transfer coefficients, h_C and h_D as discussed in an earlier chapter. It has been shown that for air-water vapor mixtures,

$$H_{\text{mass}} \approx h_o / c_{\text{pm}} \text{ or } h_o / h_{\text{mass}} \cdot c_{\text{pm}} = \text{Lewis number} \approx 1.0$$

Where c_{pm} is the humid air specific heat ≈ 1.0216 kJ/kg.K. Hence the total heat transfer is given by:

$$Q_T = Q_S + Q_L = h_o A_S (t_i - t_a) + h_{\text{mass}} A_S (W_i - W_a) h_{\text{fg}} = (h_o A_S / c_{\text{pm}}) [(t_i - t_a) + (W_i - W_a) h_{\text{fg}}]$$

by manipulating the term in the parenthesis of RHS, it can be shown that:

$$Q_T = Q_S + Q_L = (h_o A_S / c_{\text{pm}}) [(h_i - h_a)]$$

The air heat transfer coefficient, h_o has been computed from the experimental correlations derived in [3]. The heat transfer parameter is written as Stanton number, St times Prandtl number, Pr to the 2/3 power. It is given as a function of Reynolds number, Re where the function was established through curve-fitting of a set of the experimental data as follow:

$$St \times Pr^{(2/3)} = 0.1123 \times Re^{-0.261}$$

Where these three dimensionless parameters are defined as:

$$St = \frac{(A_{\text{min}} \times h_o)}{(m_a \times c_{\text{pm}})}, Pr = \frac{(\mu_a \times c_{\text{pm}})}{k_a}, \text{ and } Re = \frac{(m_a \times d_o)}{(A_{\text{min}} \times \mu_a)}$$

Where,

- A_{\min} = minimum free-flow air area, (m²)
 m_a = mass flow rate of air through the cooling coil, (kg/s)
 μ_a =dynamic viscosity of air (kg/m.s)
 k_a =thermal conductivity of air (W/m. °C)
 d_o =outside diameter, (m)

5. Governing equations and methodology

The sizing of cooling coil requires solving the two energy equations of the air-side and coolant sides coupling with the heat and mass transfer equations. The design is accomplished through discretizing the cooling coil into N segments according to the number of the coil rows. The three governing equations are applied to each segment. By knowing the process data, coil geometry, and the design cooling load imposed on the coil the required surface area can be computed. The coil sizing is expressed by the face area and number of rows of a finned-tube coil for satisfying the design coil cooling load.

Process data:

- Room dB temperature/Return air dB temperature (°C)
- Fresh air dB temperature (°C)
- Dehumidified air flow (cfm or m³/s)
- Fresh air quantity (cfm or m³/s)
- Grand sensible heat factor (GSHF)
- Coil cooling load (kW)
- Apparatus dew point ADP (°C) (This denotes the average outside surface temperature of the coil.)

Coil geometry :

- Outside tube diameter, d_o (mm)
- Inside tube diameter, d_i (mm)
- Longitudinal tube spacing, S_L (mm) (see Figure 3)
- Transverse tube spacing, S_T (mm) (see Figure 3)
- No. of fins/m, N_f
- Aluminum fin thickness, t_f (mm)
- Exchanger compactness, surface area over exchanger volume, β (m²/m³)

Air-Side

$$\Delta Q_{ci} = m_a(h_{a_i} - h_{a_{i+1}}) \quad (1)$$

$$\Delta Q_{ci} = \frac{\eta_s}{c_{pm}} h_o \Delta A_o (h_{a_{mi}} - h_{s_{mi}}) \quad (2)$$

Water-Side

$$\Delta Q_{ci} = m_w C_{pw} (T_{w_{i+1}} - T_{w_i}) \quad (3)$$

$$\Delta Q_{ci} = h_i \Delta A_i (T_{s_{mi}} - T_{w_{mi}}) \quad (4)$$

Here,

$$ha_{mi} = \frac{(ha_i + ha_{i+1})}{2}, \quad ha_{i+1} = 2ha_{mi} - ha_i \quad (5)$$

$$Tw_{mi} = \frac{(Tw_i + Tw_{i+1})}{2}, \quad Tw_{i+1} = 2Tw_{mi} - Tw_i \quad (6)$$

Eliminate ha_{i+1} and Tw_{i+1} from Equation (1) & (3) respectively, the energy equations can be formulated;

$$\Delta Q_{ci} = 2m_a(ha_i - ha_{mi}) \quad (7)$$

$$\Delta Q_{ci} = 2m_w c_{pw}(Tw_{mi} - Tw_i) \quad (8)$$

Eliminate ha_{mi} between equations (2) & (7), it is yielded:

$$\Delta Q_{ci} = \frac{\eta_s h_o \Delta A_o / c_{pm}}{1 + \Delta NTU_o / 2} * (ha_i - hs_{mi}) \quad (9)$$

Similarly, eliminate Tw_{mi} between equations (4) and (8):

$$\Delta Q_{ci} = \frac{h_i \Delta A_i}{1 + \Delta NTU_i / 2} * (Ts_{mi} - Tw_i) \quad (10)$$

Now, by dividing equation (9) over equation (10):

$$\frac{ha_i - hs_{mi}}{Ts_{mi} - Tw_i} = R \quad (11)$$

Where,

$$R = \left[\frac{h_i c_{pm}}{h_o \eta_s} \left(\frac{\Delta A_i}{\Delta A_o} \right) \right] * \left[\frac{\left(1 + \frac{\Delta NTU_o}{2} \right)}{\left(1 + \frac{\Delta NTU_i}{2} \right)} \right] \quad (12)$$

$$\Delta NTU_o = \frac{\eta_s h_o \Delta A_o}{m_a c_{pm}}, \quad \Delta NTU_i = \frac{h_i \Delta A_i}{m_w c_{pw}}$$

Relation between hs and Ts :

a. Dry-Surface ($Ts > T_{dew}$ point)

$$hs_{mi} = h_a + c_p (Ts_{mi} - T_a) \quad (13)$$

b. Wet-Surface ($Ts < T_{dew}$ point)

When the coil is wet the enthalpy of saturated air hs_{mi} is a function of the temperature of the wetted surface Ts_{mi} , by curve fitting for psychometric chart [2] of the saturated air enthalpy at different air temperatures of a range 3 to 11°C. The quadric equation is expressed as :

$$hs_{mi} = 10.76 + 1.4 Ts_{mi} + 0.046 Ts_{mi}^2 \quad (14)$$

Solution for Ts_{mi} :

Substituting for hs_{mi} from equations (14) into equation (11), we obtain a solution for Ts_{mi} as follows:

Wet Surface:

$$ha_i - hs_{mi} = R(Ts_{mi} - Tw_i)$$

$$ha_i - (10.76 + 1.4 * Ts_{mi} + 0.046 * Ts_{mi}^2) = R(Ts_{mi} - Tw_i) ,$$

$$0.046 Ts_{mi}^2 + (R + 1.4) * Ts_{mi} - (ha_i + R * Tw_i - 10.76) = 0$$

The above equation can write as:

$$aTs_{mi}^2 + bTs_{mi} - c = 0$$

This quadratic equation can now be solved for Tsm as

$$Ts_m = \frac{-b \pm \sqrt{b^2 - 4ac}}{2a} \quad (15)$$

Where,

$$a = 0.046 \quad , \quad b = R + 1.4 \quad \text{and} \quad c = ha_i + R * Tw_i - 10.76$$

Solution of ΔQ_{ci} , ha_{i+1} , Tw_{i+1}

$$\Delta Q_{ci} = \frac{h_i \Delta A_i}{1 + \Delta NTU_i / 2} * (Ts_{mi} - Tw_i), \quad ha_{i+1} = ha_i - \frac{\Delta Q_{ci}}{m_a} \quad , \quad Tw_{i+1} = Tw_i - \frac{\Delta Q_{ci}}{m_w C_{pw}}$$

Calculation of air dry-bulb temperature, Ta_{i+1}

The sensible heat transferred to the dry coil surface is written as:

$$\Delta Q_{ci} = m_a c_{pa} (Ta_i - Ta_{i+1}) \quad (16)$$

$$\Delta Q_{ci} = \eta_s h_o \Delta A_o (Ta_{mi} - Ts_{mi}) \quad (17)$$

or,

$$Q_{ci} = \eta_s h_o \Delta A_o \left(\frac{Ta_{i+1} + Ta_i}{2} - Ts_{mi} \right) \quad (18)$$

Eliminate ΔQ_{si} between equations (15) & (16) and Solving for Ta_{i+1}

$$Ta_{i+1} = \left[\frac{\left(1 - \frac{\Delta NTU_o}{2}\right)}{\left(1 + \frac{\Delta NTU_o}{2}\right)} \right] \times Ta_i + \left[\frac{\left(\frac{\Delta NTU_o}{2}\right)}{\left(1 + \frac{\Delta NTU_o}{2}\right)} \right] \times Ts_{mi} \quad (19)$$

Calculation of Wa_{i+1} :

$$Wa_{i+1} = \left[\frac{(ha_{i+1} - c_{pa} \times Ta_{i+1})}{(2501 + 1.8 \times Ta_{i+1})} \right] \quad (20)$$

Summary of final solution:

The final solutions for the coil capacity per row and for the states of air and water at the exit of any row within a chilled-water coil are given, in terms of the mean outer surface temperature of this row, as:

$$Ts_{mi} = \frac{-(R+1.4) + \sqrt{(R+1.4)^2 + 0.184 \times (ha_i + R \times Tw_i - 10.76)}}{0.092} \quad (21)$$

$$\Delta Q_{ci} = \frac{h_i \Delta A_i}{1 + \Delta NTU_i / 2} * (T_{s_{mi}} - T_{w_i})$$

$$T_{w_{i+1}} = T_{w_i} - \frac{\Delta Q_{ci}}{m_w C_{p_w}} \quad (22)$$

$$h_{a_{i+1}} = h_{a_i} - \frac{\Delta Q_{ci}}{m_a} \quad (23)$$

$$T_{a_{i+1}} = \left[\frac{\left(1 - \frac{\Delta NTU_o}{2}\right)}{\left(1 + \frac{\Delta NTU_o}{2}\right)} \right] * T_{a_i} + \left[\frac{\left(\Delta NTU_o\right)}{\left(1 + \frac{\Delta NTU_o}{2}\right)} \right] * T_{s_{mi}} \quad (24)$$

$$W_{a_{i+1}} = \left[\frac{(h_{a_{i+1}} - c_{pa} * T_{a_{i+1}})}{(2501 + 1.8 * T_{a_{i+1}})} \right] \quad (25)$$

Where,

$$R = \left[\frac{h_i c_{pa}}{h_o \eta_s} \left(\frac{\Delta A_i}{\Delta A_o} \right) \right] * \left[\frac{\left(1 + \frac{\Delta NTU_o}{2}\right)}{\left(1 + \frac{\Delta NTU_i}{2}\right)} \right] \quad (26)$$

$\Delta NTU_o = \frac{\eta_s h_o \Delta A_o}{m_a c_{pm}}$, $\Delta NTU_i = \frac{h_i \Delta A_i}{m_w C_{p_w}}$, and the total coil cooling load Q_C is: $Q_C = \sum_{i=1}^{N_r} \Delta Q_{ci}$

Calculation of the Number of Coil Rows, N_r :

The calculations of $(T_{w_{i+1}}, h_{a_{i+1}}, T_{a_{i+1}},$ and $\Delta Q_{ci})$ are started from the first row until reaching the row number N_r at which its outlet water temperature is nearly equal to the given inlet water temperature to the coil, i.e. $T_{w_{N_r+1}} \cong T_{w_{in}}$.

Procedure of cooling coil design at a given cooling load Q_C :

1. The condition of the air leaving a chilled-water coil is nearly saturated, therefore, the relative humidity of the outlet air, ϕ_{out} from the coil can be assumed as 95 %.
2. Knowing [inlet air state, $CSHF = Q_s / Q_C$, and ϕ_{out} , the enthalpy of the outlet air $h_{a_{out}}$ from the coil can then be determined from the Psychrometric Chart.
3. Knowing [Q_C , $h_{a_{in}}$, and $h_{a_{out}}$], then the air flow rate can be determined as:

$$m_a = \frac{Q_C}{(h_{a_{in}} - h_{a_{out}})} \quad \text{kg/s}$$

4. Knowing [Q_C , $T_{w_{in}}$, and $T_{w_{out}}$], the water flow rate can be determined as:

$$m_w = \frac{Q_C}{C_{p_w}(T_{w_{out}} - T_{w_{in}})} \quad \text{kg/s}$$

5. Knowing [m_a , V_{face} , ρ_a , β , and S_L], the outer surface area per row ΔA_o can be determined as:

$$\Delta A_o = \left[\frac{(\beta * S_L * m_a)}{(\rho_a * V_{face})} \right] \text{ m}^2$$

6. Starting the calculations of the unknowns [$T_{s_{mi}}$, ΔQ_{ci} , $h_{a_{i+1}}$, $T_{w_{i+1}}$, $T_{a_{i+1}}$, $W_{a_{i+1}}$] using in order equations (14, 10, 3, 1, 17, and 18), from the first row, $i=1$ to the row $i=N_r$ at which $T_{w_{N_r+1}} \cong T_{w_{in}}$. The calculations are then completed and as a final check, calculate the $CSHF$ and compare it with the given one.

6. Worked example of chilled-Water coils

Cross-counter flow chilled water cooling coil using corrugated plate-fins, has the flowing construction and operating design parameters:

Coil construction parameters:

Outside tube diameter, d_o	=13.41 mm
Inside tube diameter, d_i	=12.09 mm
Longitudinal tube spacing, S_L	=26.16 mm
Transverse tube spacing, S_T	=31.75 mm
No. of fins/m, N_f	=554
Aluminum fin thickness, t_f	=0.15 mm
Exchanger compactness, β	= 1060 m ² /m ³
Outside area/inside area, (A_o/A_i)	=23
A_{flow}/A_{face} on the air-side, σ	=0.529
Finned-surface weighted efficiency, η_s	= 0.85
Number of tube-passes per water loop, N_p	= 6

Design operating Data:

Moist air

Total cooling load at full load, Q_c	=60 kW
Latent Load at full load, Q_L	=20 kW
Inlet air conditions	= t =Dry and wet bulb temperatures are: 26 °C, and 19 °C
Air face velocity, V_{face}	=2.8 m/s
Air heat transfer coefficient, h_c	=60 W/ (m ² °C)
Air mean specific heat, c_{pm}	=1.001 kJ/(kg. K)

Chilled water

Inlet water temperature, $T_{w_{in}}$	=6 °C
Water mass flow rate, m_w	=2.9 kg/s
Water inlet velocity, V_w	=1.25 m/s
Heat transfer coefficient on water side, h_i	=4000 W/ (m ² °C)
Number of tube-passes per water loop, N_{tp}	= 6
Exit water temperature, $T_{w_{out}}$	=11 °C
Water specific heat, CP_w	=4.14 kJ/(kg. K)

Under the above design full load conditions, calculate:

- The coil dimensions (tube length, finned width and coil depth).
- The number of coil rows and the total number of tubes.
- The exit air temperature.

Calculation Procedures

From psychometric chart at inlet air conditions the inlet air properties are obtained represented by $h_{a_{in}}=54$ kJ/kg, $W_{a_{in}}=0.011$ kg_v/kg_a. and dew point temperature, $d_{pt} = 15.5^\circ\text{C}$. By knowing $Q_c=60$ kW, $CSHF=0.75$ ($=1- Q_L/Q_c$), and $\phi_{out} = 95\%$ using information from inlet point, the exit conditions can be determined as $h_{a_{out}}=33$ kJ/kg, $T_{a_o}=10.5$ °C, $W_{a_o} = 0.008936$ kg_v /kg_a

$$- m_a = \frac{Q_c}{(h_{a_{in}} - h_{a_{out}})} = \frac{60}{(54 - 33)} = 2.857 \text{ kg/s}$$

$$- m_w = \frac{Q_c}{Cp_w(Tw_{out} - Tw_{in})} = \frac{60}{4.14 \times 5} = 2.90 \text{ kg/s}$$

Calculations of the coil design parameters:

$$\Delta A_o = \frac{\beta \times S_L \times m_a}{\rho_a \times V_{face}} = \frac{1060 \times 0.02616 \times 2.857}{1.16 \times 2.8} = 24.39 \text{ m}^2$$

$$\Delta NTU_o = \frac{\eta_s h_o \Delta A_o}{m_a c_{pm}} = \frac{0.85 \times 60 \times 24.39}{2.857 \times 1001} = 0.435$$

$$\Delta A_i = \left(\frac{A_i}{A_o} \right) \times \Delta A_o = \frac{24.39}{23} = 1.06 \text{ m}^2$$

$$\Delta NTU_i = \frac{h_i \Delta A_i}{m_w c_{pw}} = \frac{4000 \times 1.06}{2.9 \times 4114} = 0.355$$

$$R = \left[\frac{h_i c_{pa}}{h_o \eta_s} \left(\frac{\Delta A_i}{\Delta A_o} \right) \right] * \left[\frac{\left(1 + \frac{\Delta NTU_o}{2} \right)}{\left(1 + \frac{\Delta NTU_i}{2} \right)} \right] = 3.525 \text{ KJ/kg.K}$$

Row i=1:

$$T_{sm1} = \frac{-(R+1.4) + \sqrt{(R+1.4)^2 + 0.184 \times (h_{a1} + R \times Tw_1 - 10.76)}}{0.092} = 14.65 \text{ }^\circ\text{C}$$

$$\Delta Q_{c1} = \frac{h_i \Delta A_i}{1 + \Delta NTU_i / 2} \times (T_{sm1} - Tw_1) = 13.15 \text{ kW}$$

Where, $h_i = 4000 \text{ W/m}^2 \cdot \text{C}$

$$Tw_2 = Tw_1 - \frac{\Delta Q_{c1}}{m_w c_{pw}} = 11 - \frac{13.15}{2.9 \times 4.14} = 9.9 \text{ }^\circ\text{C}$$

$$h_{a2} = h_{a1} - \frac{\Delta Q_{c1}}{m_a} = 49.4 \text{ kJ/kg}$$

$$Ta_{i+1} = \left[\frac{\left(1 - \frac{\Delta NTU_o}{2} \right)}{\left(1 + \frac{\Delta NTU_o}{2} \right)} \right] \times Ta_1 + \left[\frac{\left(\Delta NTU_o \right)}{\left(1 + \frac{\Delta NTU_o}{2} \right)} \right] \times T_{sm1} = 21.87 \text{ }^\circ\text{C}$$

$$Wa_2 = \frac{h_{a2} - c_{pa} Ta_2}{2501 + 1.8 \times Ta_2} = \frac{49.4 - 1(21.87)}{2501 + 1.8(21.87)} = 0.01083 \text{ kg}_v/\text{kg}_a$$

Row i=2

$$T_{sm2} = \frac{-(R+1.4) + \sqrt{(R+1.4)^2 + 0.184 \times (h_{a2} + R \times Tw_2 - 10.76)}}{0.092} = 13.28 \text{ }^\circ\text{C}$$

$$\Delta Q_{c2} = \frac{h_i \Delta A_i}{1 + \Delta NTU_i / 2} \times (T_{sm2} - Tw_2) = 12.17 \text{ kW}$$

$$Tw_3 = Tw_2 - \frac{\Delta Q_{c2}}{m_w c_{pw}} = 9.9 - \frac{12.17}{2.9 \times 4.14} = 8.89 \text{ }^\circ\text{C}$$

$$h_{a3} = h_{a2} - \frac{\Delta Q_{c2}}{m_a} = 45.14 \text{ kJ/kg}$$

$$Ta_3 = \left[\frac{\left(1 - \frac{\Delta NTU_o}{2}\right)}{\left(1 + \frac{\Delta NTU_o}{2}\right)} \right] \times Ta_2 + \left[\frac{\left(\Delta NTU_o\right)}{\left(1 + \frac{\Delta NTU_o}{2}\right)} \right] \times Ts_{m2} = 18.74 \text{ }^\circ\text{C}$$

$$Wa_3 = \frac{ha_3 - CpaTa_3}{2501 + 1.8 \times Ta_3} = \frac{45.14 - 1(18.74)}{2501 + 1.8(18.74)} = 0.0104 \text{ kg}_v/\text{kg}_a$$

Row i=3

$$Ts_{m3} = \frac{-(R+1.4) + \sqrt{(R+1.4)^2 + 0.184 \times (ha_3 + R \times Tw_3 - 10.76)}}{0.092} = 12.0 \text{ }^\circ\text{C}$$

$$\Delta Q_{c3} = \frac{h_i \Delta A_i}{1 + \Delta NTU_i/2} \times (Ts_{m3} - Tw_3) = 11.2 \text{ kW}$$

$$Tw_4 = Tw_3 - \frac{\Delta Q_{c3}}{m_w C p_w} = 8.89 - \frac{11.2}{2.9 \times 4.14} = 7.96 \text{ }^\circ\text{C}$$

$$ha_4 = ha_3 - \frac{\Delta Q_{c3}}{m_a} = 41.22 \text{ kJ/kg}$$

$$Ta_4 = \left[\frac{\left(1 - \frac{\Delta NTU_o}{2}\right)}{\left(1 + \frac{\Delta NTU_o}{2}\right)} \right] \times Ta_3 + \left[\frac{\left(\Delta NTU_o\right)}{\left(1 + \frac{\Delta NTU_o}{2}\right)} \right] \times Ts_{m3} = 16.27 \text{ }^\circ\text{C}$$

$$Wa_4 = \frac{ha_4 - CpaTa_4}{2501 + 1.8 \times Ta_4} = \frac{41.22 - 1(16.27)}{2501 + 1.8(16.27)} = 0.00986 \text{ kg}_v/\text{kg}_a$$

Row i=4

$$Ts_{m4} = \frac{-(R+1.4) + \sqrt{(R+1.4)^2 + 0.184 \times (ha_4 + R \times Tw_4 - 10.76)}}{0.092} = 10.8 \text{ }^\circ\text{C}$$

$$\Delta Q_{c4} = \frac{h_i \Delta A_i}{1 + \Delta NTU_i/2} \times (Ts_{m4} - Tw_4) = 10.22 \text{ kW}$$

$$Tw_5 = Tw_4 - \frac{\Delta Q_{c4}}{m_w C p_w} = 7.96 - \frac{10.22}{2.9 \times 4.14} = 7.11 \text{ }^\circ\text{C}$$

$$ha_5 = ha_4 - \frac{\Delta Q_{c4}}{m_a} = 37.64 \text{ kJ/kg}$$

$$Ta_5 = \left[\frac{\left(1 - \frac{\Delta NTU_o}{2}\right)}{\left(1 + \frac{\Delta NTU_o}{2}\right)} \right] \times Ta_4 + \left[\frac{\left(\Delta NTU_o\right)}{\left(1 + \frac{\Delta NTU_o}{2}\right)} \right] \times Ts_{m4} = 14.27 \text{ }^\circ\text{C}$$

$$Wa_5 = \frac{ha_5 - CpaTa_5}{2501 + 1.8 \times Ta_5} = \frac{37.64 - 1(14.27)}{2501 + 1.8(14.27)} = 0.00925 \text{ kg}_v/\text{kg}_a$$

Row i=5

$$Ts_{m5} = \frac{-(R+1.4) + \sqrt{(R+1.4)^2 + 0.184 \times (ha_5 + R \times Tw_5 - 10.76)}}{0.092} = 9.68 \text{ }^\circ\text{C}$$

$$\Delta Q_{c5} = \frac{h_i \Delta A_i}{1 + \Delta NTU_i/2} \times (Ts_{m5} - Tw_5) = 9.25 \text{ kW}$$

$$Tw_6 = Tw_5 - \frac{\Delta Q_{c5}}{m_w C p_w} = 7.11 - \frac{9.25}{2.9 \times 4.14} = 6.34 \text{ }^\circ\text{C}$$

$$ha_6 = ha_5 - \frac{\Delta Q_{c5}}{m_a} = 34.40 \text{ kJ/kg}$$

$$Ta_6 = \left[\frac{\left(1 - \frac{\Delta NTU_0}{2}\right)}{\left(1 + \frac{\Delta NTU_0}{2}\right)} \right] \times Ta_5 + \left\{ \left[\frac{(\Delta NTU_0)}{\left(1 + \frac{\Delta NTU_0}{2}\right)} \right] \right\} \times Ts_{m5} = 12.59 \text{ }^\circ\text{C}$$

$$Wa_6 = \frac{ha_6 - c_p a Ta_6}{2501 + 1.8 \times Ta_6} = \frac{34.40 - 1(12.59)}{2501 + 1.8(12.59)} = 0.00864 \text{ kg}_v/\text{kg}_a$$

Row i=6

$$Ts_{m6} = \frac{-(R+1.4) + \sqrt{(R+1.4)^2 + 0.184 \times (ha_6 + R \times Tw_6 - 10.76)}}{0.092} = 8.645 \text{ }^\circ\text{C}$$

$$\Delta Q_{c6} = \frac{h_i \Delta A_i}{1 + \Delta NTU_i/2} \times (Ts_{m6} - Tw_6) = 8.3 \text{ kW}$$

$$Tw_7 = Tw_6 - \frac{\Delta Q_{c6}}{m_w c_{p_w}} = 6.34 - \frac{8.3}{2.9 \times 4.14} = 5.65 \text{ }^\circ\text{C}$$

$$ha_7 = ha_6 - \frac{\Delta Q_{c6}}{m_a} = 31.50 \text{ kJ/kg}$$

$$Ta_7 = \left[\frac{\left(1 - \frac{\Delta NTU_0}{2}\right)}{\left(1 + \frac{\Delta NTU_0}{2}\right)} \right] \times Ta_6 + \left\{ \left[\frac{(\Delta NTU_0)}{\left(1 + \frac{\Delta NTU_0}{2}\right)} \right] \right\} \times Ts_{m6} = 11.14 \text{ }^\circ\text{C}$$

$$Wa_7 = \frac{ha_7 - c_p a Ta_7}{2501 + 1.8 \times Ta_7} = \frac{31.50 - 1(11.14)}{2501 + 1.8(11.14)} = 0.0081 \text{ kg}_v/\text{kg}_a$$

$$Q_c = \sum_{i=1}^{N_r} \Delta Q_{ci} = (13.15 + 12.17 + 11.12 + 10.22 + 9.25 + 8.3)$$

The total calculated cooling load for 6-rows coil is: $Q_c = 64.31 \text{ kW}$

And coil sensible heat factor, $CSHF = \frac{Q_s}{Q_c} = \frac{m_a c_p (Ta_1 - Ta_7)}{64.31} = 0.66$

The calculated unknowns are listed row-by-row in the next Table; and the psychrometric process for the cooling and dehumidification process is represented by Figure 6.

Row number	Surface condition	$T_{s_{mi}}$ $^\circ\text{C}$	ΔQ_{Ci} kW	Tw_{i+1} $^\circ\text{C}$	ha_{i+1} kJ/kg	Ta_{i+1} $^\circ\text{C}$	Wa_{i+1} g_v/kg_a
Coil inlet	wet		0	11	54	26	11
1	wet	14.65	13.15	9.9	49.4	21.87	10.83
2	Wet	13.28	12.17	8.89	45.14	18.74	10.4
3	Wet	12	11.2	7.96	41.22	16.27	9.86
4	Wet	10.8	10.22	7.11	37.64	14.27	9.25
5	Wet	9.68	9.25	6.34	34.40	12.59	8.64
6	Wet	8.65	8.3	5.65	31.5	11.14	8.1

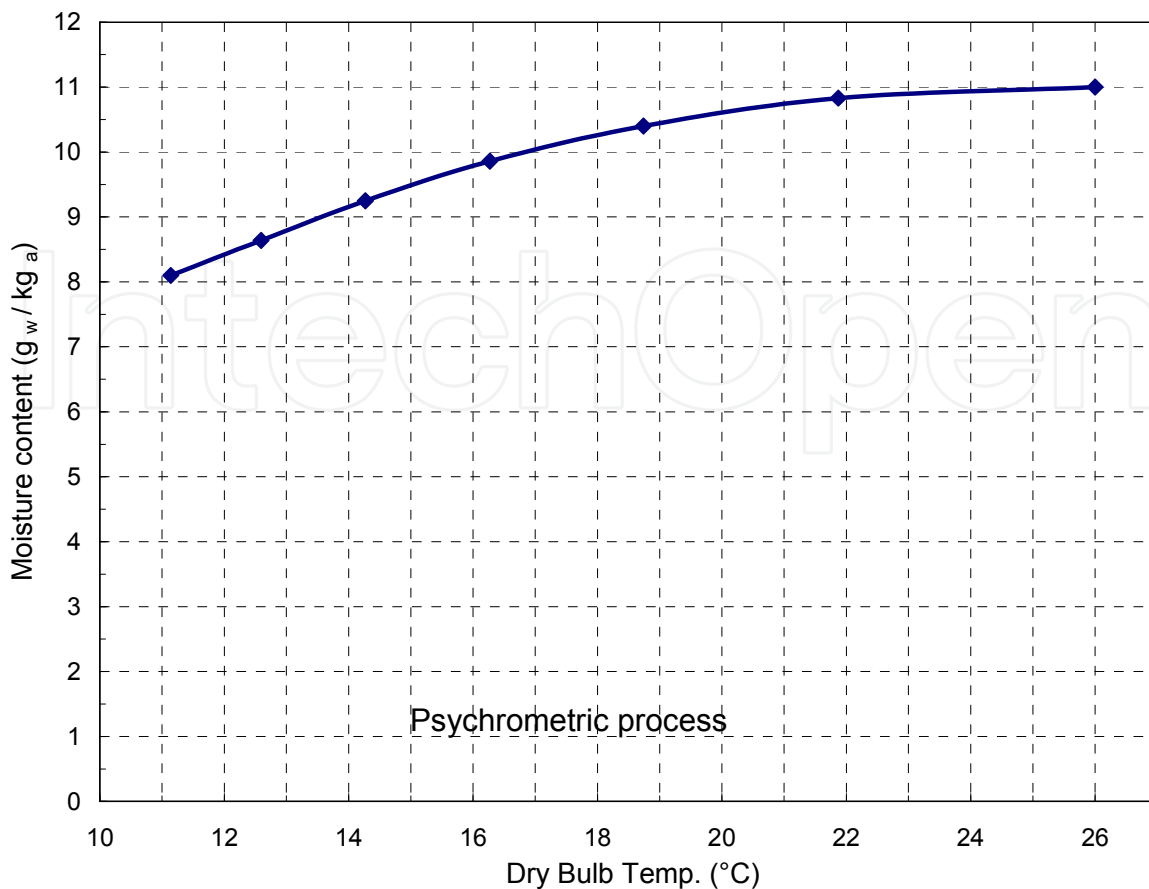

Fig. 6. Presentation of Cooling and dehumidifying process.

- a. Calculation of Coil number of tubes, N_t

$$N_r = \text{Number of coil rows} = 6$$

$$m_w = \frac{N_t}{N_p} \rho_w \left(\frac{\pi}{4} d_i^2 \right) V_w$$

$$N_t = \frac{4N_p m_a}{\pi \rho_w d_i^2 V_w} = 120 \text{ tubes}$$

- b. Calculation of Coil dimension (D, H, L)

$$N_t = N_r * N_c$$

$$N_c = \frac{120}{6} = 20$$

Height of the coil, $H = S_t * N_c = 0.635 \text{ m}$

$$A_o = \sum_{i=1}^{N_r} \Delta A_o = N_r * \Delta A_o = 6 * 24.39 = 146.34 \text{ m}^2$$

Given: $\frac{A_o}{A_i} = 23$

$$A_i = 6.363 \text{ m}^2 = N_t (\pi d_i L)$$

$$L = \text{Length of the coil} = \frac{A_i}{\pi N_t d_i} = 1.4 \text{ m}$$

$$D = \text{Coil depth} = N_c * S_L = 0.157 \text{ m}$$

c. Exit air temperature

$$T_{a_{out}} = 11.14 \text{ }^\circ\text{C}$$

Design of the cooling coil as single Region

In calculating the surface area of the cooling coil, the heat and mass transfer equations are applied on the entire coil surface. This approximation will greatly simplify the analysis. The obtained results (A_o , $T_{a_{out}}$) for one-section coil will be compared with the corresponding results obtained for N_r -sections coil.

Air-side

$$Q_c = m_a(ha_1 - ha_2) \quad (1)$$

$$Q_c = \frac{\eta_s}{c_p} h_o A_o (ha_m - hs_m) \quad (2)$$

Water-side

$$Q_c = m_w C p_w (T w_2 - T w_1) \quad (3)$$

$$Q_c = h_i A_i (T s_m - T w_m) \quad (4)$$

Applying the heat transfer equations for the air and water at the inlet and exit sections of the coil, this leads to the following equation for T_s at these sections:

$$R = \frac{ha_1 - hs_1}{T s_1 - T w_1} = \frac{ha_2 - hs_2}{T s_2 - T w_2} \quad (5)$$

For an entire wet-surface, the saturated air temperature at the inlet and exit of the coil surfaces T_{s_1} and T_{s_2} are obtained, in a similar manner as done before for N -sections coil, as:

$$T_{s_1} = \frac{-(R+1.4) + \sqrt{(R+1.4)^2 + 0.184 * (ha_1 + R * T w_1 - 10.76)}}{0.092} \quad (6)$$

$$T_{s_2} = \frac{-(R+1.4) + \sqrt{(R+1.4)^2 + 0.184 * (ha_2 + R * T w_2 - 10.76)}}{0.092} \quad (7)$$

Where,

$T w_1$ = inlet water temperature

$T w_2$ = exit water temperature

$$R = \left[\frac{c_{pa} h_i}{\eta_s h_o} \left(\frac{A_i}{A_o} \right) \right] \quad (8)$$

Knowing (T_{s_1} & $T w_1$) and (T_{s_2} & $T w_2$), the mean temperature difference between the chilled water and the coil surface can be assumed equal to the logarithmic mean temperature difference. ΔT_m can be determined from:

$$\Delta T_{W_m} = (T_{S_m} - T_{W_m}) = \frac{[(T_{S_1} - T_{W_1}) - (T_{S_2} - T_{W_2})]}{\ln\left[\frac{(T_{S_1} - T_{W_1})}{(T_{S_2} - T_{W_2})}\right]} \quad (9)$$

The area of the coil can now be determined from equation (4) as:

$$A_i = \frac{Q_c}{h_i \Delta T_m} \quad (10)$$

The outer coil surface area A_o is determined from

$$A_o = \left(\frac{A_o}{A_i}\right) A_i \quad (11)$$

The volume of the cooling coil is given as:

$$\text{Volume} = \text{DHL}$$

$$\text{DHL} = \beta A_o \quad (12)$$

Number of Coil Tubes N_t :

$$m_w = \frac{N_t}{N_p} \rho_w \left(\frac{\pi}{4} d_i^2\right) V_w$$

$$N_t = \frac{4N_p m_a}{\pi \rho_w d_i^2 V_w} \quad (13)$$

The Length of the Tube (Coil), L:

$$L = \frac{A_i}{N_t \pi d_i} \quad (14)$$

The Coil Face Area, A_{face} :

$$A_{face} = HL = \frac{m_a}{\rho_a V_{face}} \quad (15)$$

From Equations (14) and (15) H can be determined as:

$$H = \left(\frac{m_a}{\rho_a V_{face}}\right) * \left(\frac{N_t \pi d_i}{A_i}\right) \quad (16)$$

Number of Rows, N_r :

$$N_r = \frac{W}{S_r} \quad (17)$$

Depth of the Coil D:

$$D = N_r * S_L \quad (18)$$

Calculation of exit air Temperature:

The temperature difference between the air stream and the coil surface is approximated as arithmetic mean temperature difference as shown from the heat transfer equation for the dry air.

$$Q_s = m_a C_{p_a} (T_{a_1} - T_{a_2}) \quad (19)$$

$$Q_s = \eta_s h_o A_o \left[\frac{Ta_1 + Ta_2}{2} - \frac{Ts_1 + Ts_2}{2} \right] \quad (20)$$

$$Ta_2 = \left[\frac{\left(\frac{1 - \Delta NTU_o}{2} \right)}{\left(\frac{1 + \Delta NTU_o}{2} \right)} \right] \times Ta_1 + \left[\frac{\left(\frac{\Delta NTU_o}{2} \right)}{\left(\frac{1 + \Delta NTU_o}{2} \right)} \right] \times \left(\frac{Ts_1 + Ts_2}{2} \right) \quad (21)$$

Worked Example

We will solve the previous worked problem using principal of treating the coil as single zone/section instead of multi-sections and compare the two results.

Calculation Procedures:

1. Knowing: [$ha_{in}=54$ kJ/kg, $Wa_{in}=0.011$ kg_v/kg_a, $Q_c=60$ kW, $CSHF=0.75$, $\phi_{out} = 95\%$], from the Psychrometric-chart we obtain:

Air Exit Condition: [$ha_{out}=33$ kJ/kg, $Ta_o=10.5$ °C, $Wa_o=0.86 \cdot 10^{-3}$ kg_v/kg_a]

2. $m_a = \frac{Q_c}{(ha_{in} - ha_{out})} = \frac{60}{54 - 33} = 2.857$ kg/s
3. $m_w = \frac{Q_c}{Cp_w(Tw_{out} - Tw_{in})} = \frac{60}{4.14 \cdot 5} = 2.90$ kg/s

$$R = \left[\frac{h_i Cp_a \left(\frac{A_i}{A_o} \right)}{\eta_s h_o} \right] = 3.41 \text{ KJ/kg.K}$$

$$Ts_1 = \frac{-(R + 1.4) + \sqrt{(R + 1.4)^2 + 0.184 * (ha_1 + R * Tw_1 - 10.76)}}{0.092}$$

$$Ts_1 = 14.71 < T_{d.point} = 15 \quad [\text{Coil surface is wet}]$$

$$Ts_2 = \frac{-(R + 1.4) + \sqrt{(R + 1.4)^2 + 0.184 * (ha_2 + R * Tw_2 - 10.76)}}{0.092}$$

$$Ts_2 = 8.22 \text{ °C}$$

Calculation of ΔTw_m

$$\Delta Tw_m = (T_{sm} - Tw_m) = \frac{[(Ts_1 - Tw_1) - (Ts_2 - Tw_2)]}{\ln \left[\frac{(Ts_1 - Tw_1)}{(Ts_2 - Tw_2)} \right]}$$

$$\Delta Tw_m = 2.52 \text{ °C}$$

Calculation of A_i & A_o

$$A_i = \frac{Q_c}{h_i * \Delta T_m} = 5.95 \text{ m}^2$$

$$A_o = \left(\frac{A_o}{A_i} \right) A_i = 136.85 \text{ m}^2$$

Number of Coil Tubes N_t

$$N_t = \frac{4N_p m_w}{\pi \rho_w d_i^2 V_w} = 120 \text{ tubes}$$

The Length of the Tube (Coil), L:

$$L = \frac{A_i}{N_t \pi d_i} = 1.30 \text{ m}$$

Height of the Coil, H:

$$W = \left(\frac{m_a}{\rho_a V_{face}} \right) * \left(\frac{N_t \pi d_i}{A_i} \right) = 0.88 * 0.766 = 0.674 \text{ m}$$

Number of Rows, N_r

$$N_r = \frac{N_t}{N_c} = \frac{N_t * S_n}{W} = 5.65 \approx 6 \text{ rows}$$

Depth of the Coil, D:

$$D = N_r * S_L = 0.157 \text{ m}$$

Calculation of Exit air condition

$$T_{a_2} = \left[\frac{\left(1 - \frac{\Delta NTU_0}{2}\right)}{\left(1 + \frac{\Delta NTU_0}{2}\right)} \right] \times T_{a_1} + \left[\frac{\left(\Delta NTU_0\right)}{\left(1 + \frac{\Delta NTU_0}{2}\right)} \right] \times \left(\frac{T_{S_1} + T_{S_2}}{2} \right) = 10.95 \text{ }^\circ\text{C}$$

$$W_{a_2} = \frac{h_{a_2} - C_{pa} T_{a_2}}{2501 + 1.8 * T_{a_2}} = 0.00874 \text{ kg}_v / \text{kg}_a$$

Calculation of Latent load and CSHF

$$Q_L Q_S = 60 - 2.857 * (26 - 10.95) = 17 \text{ kWkW}$$

$$CSHF = \frac{60 - 17}{60} = 0.717$$

Table-1 illustrates a comparison of the dimensions and exit air conditions for 60 kW cooling coil analyzed as only single-section and cooling coil divided to N_r -sections ($N_r=6$).

Physical quantity	Single-section coil	6-sections coil
Air exit temperature, °C	10.95	11.14
Number of tubes	120	120
Number of rows	6	6
Coil width ,m	0.674	0.635
Coil depth, m	0.157	0.157
Coil length, m	1.3	1.4
Coil SHF	0.717	0.67
Design cooling load, kW	60	60
Actual cooling load, kW	60	64.3

Table 1.

The results presented in Table-1 indicate that cooling coil analyzed as only one-section gives results with good agreement with those obtained with the coil analyzed as 6-sections. The maximum error is 7%.

7. Worked example of partially dry chilled-water coils

Cross-counter flow chilled water cooling coil using corrugated plate-fins, has the flowing construction and operating design parameters:

Coil construction parameters:

Outside tube diameter, d_o	=12.7 mm
Inside tube diameter, d_i	=12.0 mm
Longitudinal tube spacing, S_L	=26.16 mm
Transverse tube spacing, S_T	=31.75 mm
No. of fins/m, N_f	=554
Aluminum fin thickness, t_f	=0.38 mm
Exchanger compactness, β	= 1060 m ² /m ³
Outside area/inside area, (A_o/A_i)	=23
A_{flow}/A_{face} on the air-side, σ	=0.529
Finned-surface weighted efficiency, η_s	= 0.85
Number of tube-passes per water loop, N_p	= 6

Design operating Data:

Moist air

Total cooling load at full load, Q_c	=60 kW
Latent Load at full load, Q_L	=20 kW
Inlet air conditions	= t = Dry and wet bulb temperatures are: 27 °C, and 17 °C
Air face velocity, V_{face}	=2.8 m/s
Air heat transfer coefficient, h_c	=60 W/ (m ² °C)
Air mean specific heat, c_{pm}	=1.001 kJ/(kg. K)

Chilled water

Inlet water temperature, $T_{w_{in}}$	=6 °C
Water mass flow rate, m_w	=2.9 kg/s
Water inlet velocity, V_w	=1.25 m/s
Heat transfer coefficient on water side, h_i	=4000 W/ (m ² °C)
Number of tube-passes per water loop, N_{tp}	= 6
Exit water temperature, $T_{w_{out}}$	=11 °C
Water specific heat, CP_w	=4.14 kJ/(kg. K)

Under the above design full load conditions, calculate:

- The coil dimensions (tube length, finned width and coil depth).
- The number of coil rows and the total number of tubes.
- The exit air temperature.

Calculation Procedures

From psychometric chart at inlet air conditions the inlet air properties are obtained represented by $h_{a_{in}}=48$ kJ/kg, $W_{a_{in}}=0.0081$ kg_v/kg_a, dew point temperature, $d_{pt} = 10^\circ\text{C}$. By knowing $Q_c=60$ kW, $CSHF=0.75$ ($=1- Q_L/Q_c$), and $\phi_{out} = 95\%$ using information from inlet point, the exit conditions can be determined as $h_{a_{out}}=30.6$ kJ/kg, $T_{a_o}=10.5$ °C, $W_{a_o}= 0.0078$ kg_v/kg_a

$$- m_a = \frac{Q_c}{(h_{a_{in}} - h_{a_{out}})} = \frac{60}{(48 - 30.6)} = 3.53 \text{ kg/s}$$

$$- m_w = \frac{Q_c}{Cp_w(Tw_{out} - Tw_{in})} = \frac{60}{4.14 \times 5} = 2.90 \text{ kg/s}$$

Calculations of the coil design parameters:

$$\Delta A_o = \frac{\beta \times S_L \times m_a}{\rho_a \times V_{face}} = \frac{1060 \times 0.0261 \times 3.53}{1.16 \times 2.8} = 29.95 \text{ m}^2$$

$$\Delta NTU_o = \frac{\eta_s h_o \Delta A_o}{m_a c_{pm}} = \frac{0.85 \times 60 \times 29.95}{3.53 \times 1001} = 0.432$$

$$\Delta A_i = \left(\frac{A_i}{A_o}\right) \times \Delta A_o = \frac{29.95}{23} = 1.3 \text{ m}^2$$

$$\Delta NTU_i = \frac{h_i \Delta A_i}{m_w c_{pw}} = \frac{4000 \times 1.3}{2.9 \times 4114} = 0.435$$

$$R = \left[\frac{h_i c_{pa}}{h_o \eta_s} \left(\frac{\Delta A_i}{\Delta A_o} \right) \right] * \left[\frac{\left(1 + \frac{\Delta NTU_o}{2} \right)}{\left(1 - \frac{\Delta NTU_i}{2} \right)} \right] = 5.3 \text{ KJ/kg.K}$$

Row i=1:

$$T_{Sm1} = \frac{-(R+1.4) + \sqrt{(R+1.4)^2 + 0.184 * (h_{a1} + R * Tw_1 - 10.76)}}{0.092} = 13.5 \text{ }^\circ\text{C}$$

Since the mean coil surface temperature at the 1st row is 13.5 and it is larger than the inlet dew point temperature of the entering air, $d_{pt} = 10^\circ\text{C}$ the coil will be partially dry until the coil surface temperature reaches at least the dew point temperature. Therefore, the dry coil equations will be used here.

$$T_{Sm1} = \frac{(Ta_1 + R * Tw_1)}{(R+1)} = 13.6 \text{ }^\circ\text{C}$$

$$\Delta Q_{c1} = \frac{h_i \Delta A_i}{\left(1 - \frac{\Delta NTU_i}{2} \right)} \times (T_{Sm1} - Tw_1) = 17.27 \text{ kW}$$

Where, $h_i = 4000 \text{ W/m}^2.\text{C}$

$$Tw_2 = Tw_1 - \frac{\Delta Q_{c1}}{m_w c_{pw}} = 11 - \frac{14.5}{2.9 \times 4.14} = 9.8 \text{ }^\circ\text{C}$$

$$Ta_2 = Ta_1 - \frac{\Delta Q_{c1}}{m_a \times C_{pa}} = 22.2 \text{ }^\circ\text{C}$$

$$Wa_2 = Wa_1 = 0.0081 \text{ kg}_v/\text{kg}_a$$

Row i=2

$$T_{Sm2} = \frac{(Ta_2 + R * Tw_2)}{(R+1)} = 11.81 \text{ }^\circ\text{C}$$

$$\Delta Q_{c2} = \frac{h_i \Delta A_i}{\left(1 - \frac{\Delta NTU_i}{2} \right)} \times (T_{Sm2} - Tw_2) = 13.35 \text{ kW}$$

$$TW_3 = TW_2 - \frac{\Delta Q_{c2}}{m_w C p_w} = 9.8 - \frac{11.2}{2.9 \times 4.14} = 8.86 \text{ }^\circ\text{C}$$

$$Ta_3 = Ta_2 - \frac{\Delta Q_{c1}}{m_a \times C p_a} = 18.5 \text{ }^\circ\text{C}$$

$$Wa_3 = Wa_2 = 0.0081 \text{ kg}_v/\text{kg}_a$$

Row i=3

$$T_{sm3} = \frac{(Ta_3 + R \cdot TW_3)}{(R+1)} = 10.42 \text{ }^\circ\text{C}$$

$$\Delta Q_{c3} = \frac{h_i \Delta A_i}{\left(1 - \frac{\Delta NTU_i}{2}\right)} \times (T_{sm3} - TW_3) = 10.36 \text{ kW}$$

$$TW_4 = TW_3 - \frac{\Delta Q_{c3}}{m_w C p_w} = 8.86 - \frac{8.7}{2.9 \times 4.14} = 8.13 \text{ }^\circ\text{C}$$

$$Ta_4 = Ta_3 - \frac{\Delta Q_{c1}}{m_a \times C p_a} = 15.6 \text{ }^\circ\text{C}$$

$$Wa_4 = Wa_3 = 0.0081 \text{ kg}_v/\text{kg}_a$$

Row i=4

$$T_{sm4} = \frac{(Ta_4 + R \cdot TW_4)}{(R+1)} = 9.34 \text{ }^\circ\text{C}$$

$$\Delta Q_{c4} = \frac{h_i \Delta A_i}{\left(1 - \frac{\Delta NTU_i}{2}\right)} \times (T_{sm4} - TW_4) = 8 \text{ kW}$$

$$TW_5 = TW_4 - \frac{\Delta Q_{c4}}{m_w C p_w} = 8.13 - \frac{6.75}{2.9 \times 4.14} = 7.57 \text{ }^\circ\text{C}$$

$$Ta_5 = Ta_4 - \frac{\Delta Q_{c4}}{m_a \times C p_a} = 13.3 \text{ }^\circ\text{C}$$

$$Wa_5 = Wa_4 = 0.0081 \text{ kg}_v/\text{kg}_a$$

Row i=5

$T_{sm} < dpt$ therefore, the coil will act as a wet coil

$$ha_5 = 1.001 \times Ta_5 + Wa_5 \times (2501 + 1.8 \times Ta_5) = 33.76 \text{ kJ/kg}$$

$$T_{sm5} = \frac{-(R+1.4) + \sqrt{(R+1.4)^2 + 0.184 \times (ha_5 + R \cdot TW_5 - 10.76)}}{0.092} = 9 \text{ }^\circ\text{C}$$

$$\Delta Q_{c5} = \frac{h_i \Delta A_i}{\left(1 - \frac{\Delta NTU_i}{2}\right)} \times (T_{sm5} - TW_5) = 9.5 \text{ kW}$$

$$TW_6 = TW_5 - \frac{\Delta Q_{c5}}{m_w C p_w} = 7.57 - \frac{7.97}{2.9 \times 4.14} = 7 \text{ }^\circ\text{C}$$

$$ha_6 = ha_5 - \frac{\Delta Q_{c5}}{m_a} = 31.1 \text{ kJ/kg}$$

$$Ta_6 = \left[\frac{\left(1 - \frac{\Delta NTU_o}{2}\right)}{\left(1 + \frac{\Delta NTU_o}{2}\right)} \right] \times Ta_5 + \left\{ \left[\frac{(\Delta NTU_o)}{\left(1 + \frac{\Delta NTU_o}{2}\right)} \right] \times Ts_{m5} \right\} = 11.7 \text{ }^\circ\text{C}$$

$$Wa_6 = \frac{ha_6 - c_p a Ta_6}{2501 + 1.8 \times Ta_6} = \frac{31.1 - 1(11.7)}{2501 + 1.8(11.7)} = 0.0077 \text{ kg}_v/\text{kg}_a$$

Row $i=6$

$$Ts_{m6} = \frac{-(R+1.4) + \sqrt{(R+1.4)^2 + 0.184 \times (ha_6 + R \times Tw_6 - 10.76)}}{0.092} = 8.1 \text{ }^\circ\text{C}$$

$$\Delta Q_{c6} = \frac{h_i \Delta A_i}{\left(1 - \frac{\Delta NTU_i}{2}\right)} \times (Ts_{m6} - Tw_6) = 7.31 \text{ kW}$$

$$Tw_7 = Tw_6 - \frac{\Delta Q_{c6}}{m_w c_{p_w}} = 7 - \frac{6.37}{2.9 \times 4.14} = 6.4 \text{ }^\circ\text{C}$$

$$ha_7 = ha_6 - \frac{\Delta Q_{c5}}{m_a} = 30 \text{ kJ/kg}$$

$$Ta_7 = \left[\frac{\left(1 - \frac{\Delta NTU_o}{2}\right)}{\left(1 + \frac{\Delta NTU_o}{2}\right)} \right] \times Ta_6 + \left\{ \left[\frac{(\Delta NTU_o)}{\left(1 + \frac{\Delta NTU_o}{2}\right)} \right] \times Ts_{m6} \right\} = 10.3 \text{ }^\circ\text{C}$$

$$Wa_7 = \frac{ha_7 - c_p a Ta_7}{2501 + 1.8 \times Ta_7} = \frac{30 - 1(10.3)}{2501 + 1.8(10.3)} = 0.0076 \text{ kg}_v/\text{kg}_a$$

The total calculated cooling load for 6-rows coil is: $Q_C = \sum_{i=1}^{i=N_r} Q_{Ci} = 65.8 \text{ kW}$

And coil sensible heat factor,

$$CSHF = \frac{Q_S}{Q_C} = \frac{m_a c_p (Ta_1 - Ta_7)}{65.8} = 0.88$$

The calculated unknowns are listed row-by-row in the next Table; and the psychrometric process for the cooling and dehumidification process is represented by Figure 7.

Row number	Surface condition	$T_{s_{mi}}$ $^\circ\text{C}$	ΔQ_{Ci} kW	Tw_{i+1} $^\circ\text{C}$	Ta_{i+1} $^\circ\text{C}$	Wa_{i+1} g_v/kg_a
Coil inlet	Dry		0	11	27	8.1
1	Dry	13.6	17.3	9.8	22.2	8.1
2	Dry	11.8	13.3	8.86	18.5	8.1
3	Dry	10.4	10.36	8.13	15.6	8.1
4	Dry	9.3	8	7.57	13.3	8.1
5	Wet	9.0	9.5	7	11.7	7.7
6	Wet	8.1	7.3	6.4	10.3	7.6

a. Calculation of Coil number of tubes, N_t

$$N_t = \text{Number of coil rows} = 6$$

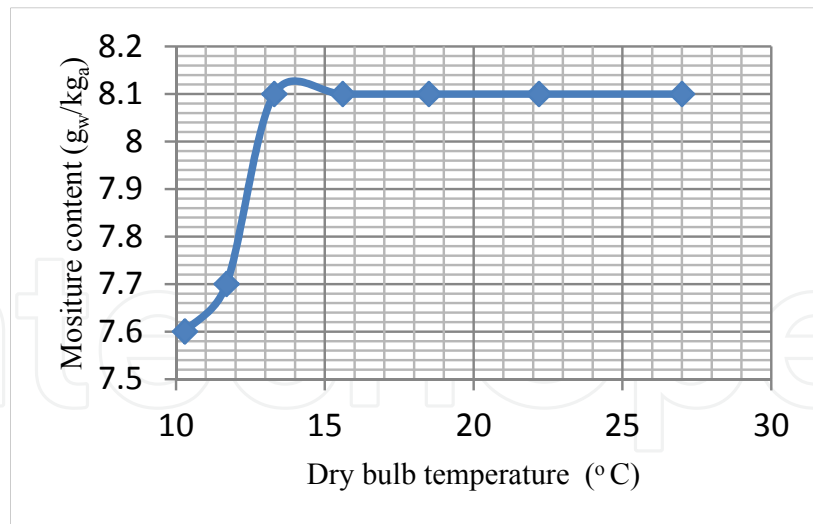

Fig. 7. Presentation of Cooling and dehumidifying process.

$$m_w = \frac{N_t}{N_p} \rho_w \left(\frac{\pi}{4} d_i^2 \right) V_w$$

$$N_t = \frac{4N_p m_a}{\pi \rho_w d_i^2 V_w} = 120 \text{ tubes}$$

b. Calculation of Coil dimension (D, H, L)

$$N_t = N_r * N_c$$

$$N_c = \frac{120}{6} = 20$$

Height of the coil, $H = S_t * N_c = 0.635 \text{ m}$

$$A_o = \sum_{i=1}^{N_r} \Delta A_o = N_r * \Delta A_o = 6 * 29.95 = 179.7 \text{ m}^2$$

Given: $\frac{A_o}{A_i} = 23$

$$A_i = 7.81 \text{ m}^2 = N_t (\pi d_i L)$$

$$L = \text{Length of the coil} = \frac{A_i}{\pi N_t d_i} = 1.71 \text{ m}$$

$$D = \text{Coil depth} = N_c * S_L = 0.157 \text{ m}$$

c. Exit air temperature

$$T_{a_{out}} = 10.3 \text{ } ^\circ\text{C}$$

Treating the cooling coil as a single zone "Worked Example"

We will solve the previous worked problem using principal treating the coil as single zone/section instead of multi-sections and compare the two results.

Calculation Procedures:

1. From psychrometric chart at inlet air conditions the inlet air properties are obtained represented by $h_{a_{in}} = 48 \text{ kJ/kg}$, $W_{a_{in}} = 0.0081 \text{ kg}_v/\text{kg}_a$, dew point temperature, $d_{pt} = 10^\circ\text{C}$.

By knowing $Q_c=60$ kW, $CSHF=0.75$ ($=1- Q_L/Q_c$), and $\phi_{out} = 95\%$ using information from inlet point, the exit conditions can be determined as $ha_{out}=30.6$ kJ/kg, $Ta_o=10.5$ °C, $Wa_o = 0.0078$ kg_v/kg_a

$$2. \quad m_a = \frac{Q_c}{(ha_{in}-ha_{out})} = \frac{60}{(48-30.6)} = 3.53 \text{ kg/s}$$

$$3. \quad m_w = \frac{Q_c}{Cp_w(Tw_{out}-Tw_{in})} = \frac{60}{4.14*5} = 2.90 \text{ kg/s}$$

$$R = \left[\frac{h_i C p_a}{\eta_s h_o} \left(\frac{A_i}{A_o} \right) \right] = 3.41 \text{ KJ/kg.K}$$

$$TS_1 = \frac{-(R + 1.4) + \sqrt{(R + 1.4)^2 + 0.184 * (ha_1 + R * Tw_1 - 10.76)}}{0.092}$$

$$TS_1 = 13.74 > T_{d.point} = 10 \quad [\text{Coil surface is dry}]$$

$$TS_1 = \frac{(Ta_1 + R * Tw_1)}{(R+1)} = 14.62^\circ \text{C}$$

$$TS_2 = \frac{(Ta_2 + R * Tw_2)}{(R+1)} = 7.02$$

Calculation of ΔTw_m

$$\Delta Tw_m = (Ts_m - Tw_m) = \frac{[(Ts_1 - Tw_1) - (Ts_2 - Tw_2)]}{\ln \left[\frac{(Ts_1 - Tw_1)}{(Ts_2 - Tw_2)} \right]}$$

$$\Delta Tw_m = 2.05 \text{ }^\circ\text{C}$$

Calculation of A_i & A_o

$$A_i = \frac{Q_c}{h_i * \Delta T_m} = 7.31 \text{ m}^2$$

$$A_o = \left(\frac{A_o}{A_i} \right) A_i = 168.3 \text{ m}^2$$

Number of Coil Tubes N_t

$$N_t = \frac{4N_p m_w}{\pi \rho_w d_i^2 V_w} = 120 \text{ tubes}$$

The Length of the Tube (Coil), L:

$$L = \frac{A_i}{N_t \pi d_i} = 1.62 \text{ m}$$

Height of the Coil, H:

$$H = \left(\frac{m_a}{\rho_a V_{face}} \right) * \left(\frac{N_t \pi d_i}{A_i} \right) = 0.683 \text{ m}$$

Number of Rows, N_r

$$N_r = \frac{N_t}{N_c} = \frac{N_t * S_t}{H} = 5.5 \approx 6 \text{ rows}$$

Depth of the Coil, D:

$$D = N_r * S_L = 0.157 \text{ m}$$

$$NTU_o = \frac{h_o A_o \eta_s}{m_a c_{p_a}} = 2.43$$

Calculation of Exit air condition

$$T_{a_2} = \left[\frac{\left(1 - \frac{NTU_o}{2}\right)}{\left(1 + \frac{NTU_o}{2}\right)} \right] \times T_{a_1} + \left[\frac{\left(\frac{NTU_o}{2}\right)}{\left(1 + \frac{NTU_o}{2}\right)} \right] \times \left(\frac{T_{s_1} + T_{s_2}}{2} \right) = 9.2^\circ\text{C}$$

$$W_{a_2} = \frac{h_{a_2} - c_{p_a} T_{a_2}}{2501 + 1.8 * T_{a_2}} = 0.008 \text{ kg}_v / \text{kg}_a$$

Calculation of Latent load and CSHF

$$Q_L Q_S = m_a (W_{a_2} - W_{a_1}) \times 2501 = 0.88 \text{ kW}$$

$$CSHF = \frac{60 - 0.88}{60} = 0.98$$

Table-2 illustrates a comparison of the dimensions and exit air conditions for 60 kW cooling coil analyzed as only single-section and cooling coil divided to N_r -sections ($N_r=6$).

Physical quantity	Single-section coil	6-sections coil
Air exit temperature, °C	9.2	10.3
Number of tubes	120	120
Number of rows	6	6
Coil width, m	0.683	0.635
Coil depth, m	0.157	0.157
Coil length, m	1.62	1.71
Coil SHF	0.98	0.71
Design cooling load, kW	60	60
Actual cooling load, kW	60	65.8

Table 2.

The results presented in Table-2 indicate that cooling coil analyzed as only one-section gives results with good agreement with those obtained with the coil analyzed as 6-sections. The maximum error is 12%.

8. Worked problem on the thermal design of Dx-coils

Cross-counter flow Dx- evaporator coil using corrugated plate-fins, has the flowing construction and operating design parameters:

Coil construction parameters:

Outside tube diameter, d_o	=13.41 mm
Inside tube diameter, d_i	=12.09 mm
Longitudinal tube spacing, S_L	=26.16 mm
Transverse tube spacing, S_T	=31.75 mm

No. of fins/m, N_f	=554
Aluminum fin thickness, t_f	=0.15 mm
Exchanger compactness, β	= 1060 m ² /m ³
Outside area/inside area, (A_o/A_i)	=23
A_{flow}/A_{face} on the air-side, σ	=0.529
Finned-surface weighted efficiency, η_s	= 0.85
Number of tube-passes per water loop, N_p	= 6

Design operating Data:

Moist air

Total cooling load at full load, Q_c	=60 kW
Latent Load at full load, Q_L	=20 kW
Inlet air conditions	= t = Dry and wet bulb temperatures are: 26 °C, and 19 °C
Air face velocity, V_{face}	=2.8 m/s
Air heat transfer coefficient, h_c	=60 W/ (m ² °C)
Air mean specific heat, c_{pm}	=1.001 kJ/(kg. K)

R-134a

Evaporating temperature, T_{ev}	=7 °C
Heat transfer coefficient on refrigerant side, h_i	=2000 W/ (m ² °C)
Number of tube-passes per water loop, N_{tp}	= 6

Under the above design full load conditions, calculate:

- The coil dimensions (tube length, finned width and coil depth).
- The number of coil rows and the total number of tubes.
- The exit air temperature.

Calculation Procedures

- Knowing: [$h_{a_{in}}=54$ kJ/kg, $W_{a_{in}}=0.011$ kgv/kg, $Q_c=60$ kW, $CSHF=0.75$, $\phi_{out} = 95\%$], from the Psychrometric-chart we obtain:

Air Exit Condition: [$h_{a_{out}}=33$ kJ/kg, $T_{a_o}=10.5$ °C, $W_{a_o}=0.86*10^{-3}$ kgv/kg]

$$2. \quad m_a = \frac{Q_c}{(h_{a_{in}} - h_{a_{out}})} = \frac{60}{(54 - 33)} = 2.857 \text{ kg/s}$$

$$3. \quad R = \left[\frac{h_i C_{p_a} \left(\frac{A_i}{A_o} \right)}{\eta_{s h_o}} \right] = 1.7 \text{ KJ/kg.K}$$

$$T_{s_1} = \frac{-(R + 1.4) + \sqrt{(R + 1.4)^2 + 0.184 * (h_{a_1} + R * T_{ev} - 10.76)}}{0.092}$$

$$T_{s_1} = 14.23 < T_{d,point} = 15 \quad [\text{Coil surface is wet}]$$

$$T_{s_2} = \frac{-(R + 1.4) + \sqrt{(R + 1.4)^2 + 0.184 * (h_{a_2} + R * T_{ev} - 10.76)}}{0.092}$$

$$T_{s_2} = 9.21 \text{ °C}$$

Calculation of ΔT_{ev_m}

$$\Delta T_{ev_m} = (T_{s_m} - T_{ev_m}) = \frac{[(T_{s_1} - T_{ev}) - (T_{s_2} - T_{ev})]}{\ln \left| \frac{(T_{s_1} - T_{ev})}{(T_{s_2} - T_{ev})} \right|}$$

$$\Delta T_{ev_m} = 5.33 \text{ } ^\circ\text{C}$$

Where, ΔT_{ev_m} = mean temperature difference on the refrigerant-side.

Calculation of A_i & A_o

$$A_i = \frac{Q_c}{h_i \cdot \Delta T_{ev_m}} = 5.63 \text{ m}^2$$

$$A_o = \left(\frac{A_o}{A_i} \right) A_i = 129.5 \text{ m}^2$$

Calculation of Exit air condition

$$T_{a_2} = \left[\frac{\left(1 - \frac{\Delta NTU_o}{2}\right)}{\left(1 + \frac{\Delta NTU_o}{2}\right)} \right] \times T_{a_1} + \left[\frac{\left(\frac{\Delta NTU_o}{2}\right)}{\left(1 + \frac{\Delta NTU_o}{2}\right)} \right] \times \left(\frac{T_{s_1} + T_{s_2}}{2} \right) = 10.75 \text{ } ^\circ\text{C}$$

$$\Delta NTU_o = \frac{\eta_s h_o A_o}{m_a c_{p_a}} = 2.30$$

Air is saturate at this temperature with $h_{a_2} = 31.5 \text{ kJ/kg}$

$$W_{a_2} = \frac{h_{a_2} - c_{p_a} T_{a_2}}{2501 + 1.8 T_{a_2}} = 0.00823 \text{ Kgv / kga}$$

Calculation of Latent load and CSHF

$$Q_c = m_a (h_{a_1} - h_{a_2}) = 64.28 \text{ kW}$$

$$Q_L = Q_c - Q_s = 64.28 - 2.857 * (26 - 10.72) = 20.62 \text{ kW}$$

$$\text{CSHF} = \frac{64.28 - 20.6}{64.28} = 0.68$$

Calculation of Dx-Coil Size

Number of Coil Tubes N_t

For DX-coil the number of tubes is determined by applying the continuity equation for the refrigerant at the exit of the coil where the velocity attains its maximum value at this exit section. Assuming the refrigerant as saturated vapor, and the maximum velocity of vapor $V_g \approx 10 \text{ m/s}$, N_t is given as:

$$m_r = \frac{Q_c}{x \cdot h_{fg}} = 0.33 \text{ kg/s} \quad [\text{Assume inlet dryness fraction, } x = 0.9]$$

$$N_t = \frac{4 N_p m_r}{\pi \rho_g d_i^2 V_g} \approx 96 \text{ tube}$$

The Length of the Tube (Coil), L

$$L = \frac{A_i}{N_t \pi d_i} = 1.54 \text{ m}$$

Height of the Coil, H

$$\text{Air face area, } A_{\text{face}} = \frac{\dot{m}_a}{\rho_a V_{\text{face}}} = 0.88 \text{ m}^2$$

$$A_{\text{face}} = HL$$

$$H = \frac{A_{\text{face}}}{L} = 0.57 \text{ m}$$

Number of Rows, N_r

$$N_r = \frac{N_t}{N_c} = \frac{N_t * S_t}{W} = 5.35 \approx 6 \text{ rows}$$

Depth of the Coil, D:

$$D = N_r * S_L = 0.157 \text{ m}$$

9. Conclusion

In this chapter, simulation of the cooling coil using a discrete technique "row-by-row method" has been presented. The main advantage of this method is to trace the air and coil surface temperature locally. In addition, this method gives more accurate results for the cooling coil design or simulation compared with those given by ordinary method such as log mean enthalpy method. Step-by-step procedure has been introduced and worked examples are presented. The deviation between the two methods "numerical discrete method and treating the coil as a single zone" is around of 12%.

10. Nomenclature

A	= surface area, m ²
C _p	= specific heat, kJ/kg. C
h	= heat transfer coefficient, W/m ² . C
h _{mass}	= mass transfer coefficient, kg/m ² .S
NTU	= number of transfer unit
Q	= heat transfer, W
T	= temperature, °C
W	= humidity ratio, kg _v /kg _a

11. References

- [1] ASHRAE Systems and Equipment Handbook (SI), 2000, Chapter 21
- [2] Wibert Stoecker, and Jerold Jones. "Refrigeration & air-conditioning", 2nd, Ed., 1982, McGraw-Hill
- [3] ASHRAE Fundamental Handbook (SI), 2001, Chapter 6
- [4] Kays, W.M., and London A.L. Compact Heat Exchangers, 3rd edition, McGraw-Hill, New York. 1984
- [5] Threlkeld, J.L. Thermal Environment Engineering, Prentice-Hall Inc., New York, NY. 1970.



Heat Exchangers - Basics Design Applications

Edited by Dr. Jovan Mitrovic

ISBN 978-953-51-0278-6

Hard cover, 586 pages

Publisher InTech

Published online 09, March, 2012

Published in print edition March, 2012

Selecting and bringing together matter provided by specialists, this project offers comprehensive information on particular cases of heat exchangers. The selection was guided by actual and future demands of applied research and industry, mainly focusing on the efficient use and conversion energy in changing environment. Beside the questions of thermodynamic basics, the book addresses several important issues, such as conceptions, design, operations, fouling and cleaning of heat exchangers. It includes also storage of thermal energy and geothermal energy use, directly or by application of heat pumps. The contributions are thematically grouped in sections and the content of each section is introduced by summarising the main objectives of the encompassed chapters. The book is not necessarily intended to be an elementary source of the knowledge in the area it covers, but rather a mentor while pursuing detailed solutions of specific technical problems which face engineers and technicians engaged in research and development in the fields of heat transfer and heat exchangers.

How to reference

In order to correctly reference this scholarly work, feel free to copy and paste the following:

M. Khamis Mansour and M. Hassab (2012). Thermal Design of Cooling and Dehumidifying Coils, Heat Exchangers - Basics Design Applications, Dr. Jovan Mitrovic (Ed.), ISBN: 978-953-51-0278-6, InTech, Available from: <http://www.intechopen.com/books/heat-exchangers-basics-design-applications/thermal-design-of-cooling-and-dehumidifying-coils>

INTECH
open science | open minds

InTech Europe

University Campus STeP Ri
Slavka Krautzeka 83/A
51000 Rijeka, Croatia
Phone: +385 (51) 770 447
Fax: +385 (51) 686 166
www.intechopen.com

InTech China

Unit 405, Office Block, Hotel Equatorial Shanghai
No.65, Yan An Road (West), Shanghai, 200040, China
中国上海市延安西路65号上海国际贵都大饭店办公楼405单元
Phone: +86-21-62489820
Fax: +86-21-62489821

© 2012 The Author(s). Licensee IntechOpen. This is an open access article distributed under the terms of the [Creative Commons Attribution 3.0 License](#), which permits unrestricted use, distribution, and reproduction in any medium, provided the original work is properly cited.

IntechOpen

IntechOpen