

We are IntechOpen, the world's leading publisher of Open Access books Built by scientists, for scientists

4,800

Open access books available

122,000

International authors and editors

135M

Downloads

Our authors are among the

154

Countries delivered to

TOP 1%

most cited scientists

12.2%

Contributors from top 500 universities



WEB OF SCIENCE™

Selection of our books indexed in the Book Citation Index
in Web of Science™ Core Collection (BKCI)

Interested in publishing with us?
Contact book.department@intechopen.com

Numbers displayed above are based on latest data collected.

For more information visit www.intechopen.com



Seismic Performance of Masonry Building

Xiaosong Ren, Pang Li, Chuang Liu and Bin Zhou
*Institute of Structural Engineer and Disaster Reduction, Tongji University,
 China*

1. Introduction

The frequent occurrence of huge earthquake in the recent years results catastrophic losses to the people's life and property, which is mainly caused by the devastation of many buildings. The Tangshan Earthquake (Ms 7.8,1976) and Wenchuan Earthquake (Ms 8.0,2008) should be mentioned here for the destructive influence on the development of China in the recent ages(Housner & Xie, 2002; Liu & Zhang,2008; Wang,2008). After the trial version of seismic design code as TJ 11-74, the Chinese seismic design code was published first in 1978 (as TJ 11-78), revised in 1989 (as GBJ 11-89) , 2000 (as GB 50011-2001) and 2010 (as GB 50011-2010). The minor earthquake, moderate earthquake and major earthquake are concerned in the seismic fortification. The moderate earthquake is defined to be of local fortification intensity. The minor earthquake means the frequent earthquake, whose intensity is about 1.5 degree lower, while the major earthquake means the rare earthquake, whose intensity is about 1 degree higher. The exceeding probability during 50 years as P_f , the maximum acceleration of ground a_{\max} and the maximum coefficient of horizontal earthquake action as α_{\max} for local fortification intensity 7 are summarized in Table 1. It is seen that the relative major earthquake action, which is defined as the ratio of major earthquake action and minor earthquake action is 6.3 for local fortification intensity 7.

Condition	P_f	a_{\max} (cm/s ²)	α_{\max}
Minor earthquake	63.2%	35	0.08
Moderate earthquake	10%	100	0.23
Major earthquake	2-3%	220	0.50

Table 1. Main parameters for local fortification intensity 7 according to the Chinese code.

In order to realize the seismic objective in China, which is defined as no failure under minor earthquake, repairable damage under moderate earthquake and no collapse under major earthquake, the seismic design procedure should be finished in two steps. The strength and lateral deformation in the elastic range must be checked under minor earthquake action, while for some specified structures, the elasto-plastic deformation analysis should also be done to verify the collapse-resistant capacity of structures under major earthquake action. Because of the relative low construction cost, masonry building is the widely used structural type in China. For this reason, the seismic damage of masonry buildings was specially investigated by the first author just after the 5.12 Wenchuan Earthquake of 2008. Based on

the seismic damage collected in the disaster area, the seismic performance of masonry building is discussed. In order to ensure the collapse-resistant capacity, the ductility of structures should be involved. It is necessary to set more margin of shear strength in the design. The method of parcelling masonry structure with reinforced concrete members is suggested to retrofit the existing masonry buildings.

2. Seismic damage caused by 5.12 Wenchuan earthquake

The severe damage of buildings caused by 5.12 Wenchuan Earthquake of 2008 is really a good lesson for engineering community to understand more about the seismic performance of structures. The first author took part in the work of site urgent structural assessment in a small mountainous county, Qingchuan County. Among the concerned 133 buildings, there are 6 buildings of reinforced concrete structure and 127 masonry buildings. Till now, there are 44 big after-shocks of magnitudes larger than Ms 5.0, while 9 big after-shocks took place in Qingchuan County, including the largest one (Ms 6.4, 16:21, May 25th, 2008). Qingchuan County belongs to the extremely heavy disaster area. The actual seismic intensity of Qingchuan County is 9, which exceeds the level of major earthquake (about intensity 8.5) of the previous fortification intensity 7 in this region.

No steel structure was found in Qingchuan County. The amount of the reinforced concrete structure is about 10% and the others are masonry buildings. The masonry buildings were constructed mainly after 1980 and seismic proof was generally considered by the previous design code. About 50% of masonry buildings collapsed or nearly collapsed while the ratio of reinforced concrete structure is about 20%. The seismic damage of masonry buildings investigated in this area is mainly stated (Lu and Ren, 2008).

2.1 Through diagonal cracks or through X-shape cracks on the wall

Through diagonal cracks or through X-shape cracks are the common earthquake induced damages on the walls of the masonry buildings, as shown in Fig.1. This kind of earthquake damage belongs to shear failure, which is caused by the principal tensile stress exceeding shear strength of masonry. The through X-shape cracks are very popular on the longitudinal walls, especially between the door or window openings of nearly every floor. The diagonal cracks usually appear mostly on the bearing transverse walls. These cracks may lead to the obvious decrease of structural capacity and even collapse of the buildings.



Fig. 1. Through diagonal or X-shape cracks on the wall

2.2 Horizontal crack on the wall

Another main seismic damage is the horizontal crack on the wall. Horizontal cracks usually appear at the wall near the elevation of floor or roof, which enlarges the damage and results in collapse of pre-cast hollow slab. Meanwhile, horizontal cracks also appear on the end of some bearing brick columns, which lead to the decrease and even loss of the structural capacity. This kind of cracks means horizontal shear failure of walls. It is deduced that the large vertical ground motion may lead to this kind of earthquake damage. Typical phenomenon of horizontal cracks on the wall is shown in Fig. 2.



Fig. 2. Horizontal cracks on the wall or the bearing brick column

2.3 Damage of the stair part

Comparing with the other parts, the damage of stair part is relative severe because of the relative large stiffness of the slope structural members. Fig. 3 shows the severe damage of the stair part in the building with irregular plan. From the layout of this building, it is seen that the stair part is the convex part of the T-shaped plan.

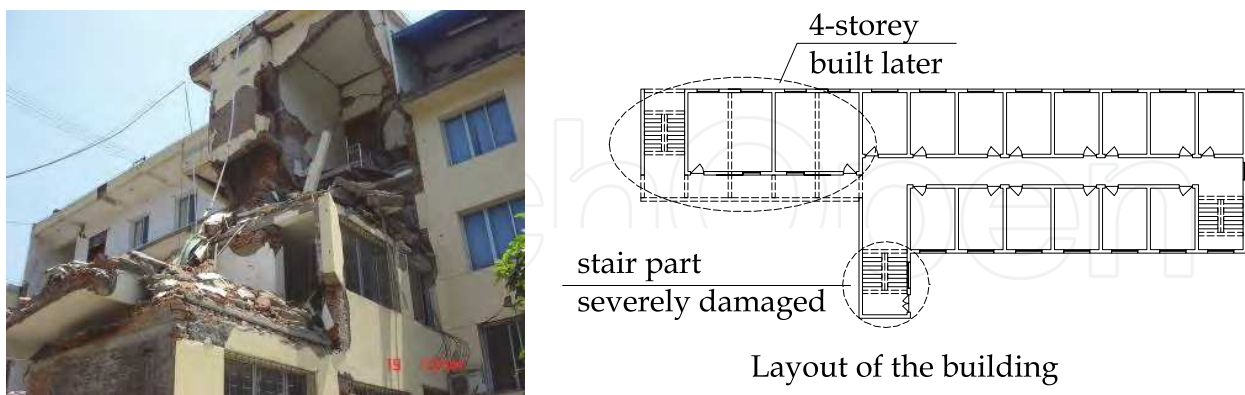

Fig. 3. Partial collapse of stair part

2.4 Damages of nonstructural components

Severe damages on nonstructural components, such as horizontal crack, diagonal crack, even partial collapse can be easily found due to no reliable connections with the main structures. Fig.4 shows the partial collapse of the parapet, which even leads to the damage of the roof slab. Fig. 5 shows the falling of the corridor fence, severe damage of the

protruding member in the roof. These are typical phenomena of the seismic induced damage of the nonstructural components.



Fig. 4. Failure of the parapet wall



Fig. 5. Falling of the corridor fence and horizontal crack of the protruding member

2.5 Damage caused or aggravated by structural irregularity

Two examples are given here to show the harmful influence of structural irregularity on the building damage. Fig. 6 shows the severe damage of the L-shaped building with unequal height. Fig.7 shows the severe damage in the part of staggered elevation.

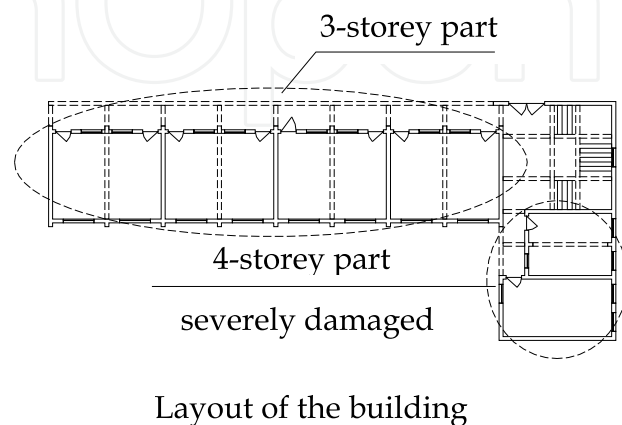

Fig. 6. Severe damage of masonry buildings with plan irregularity

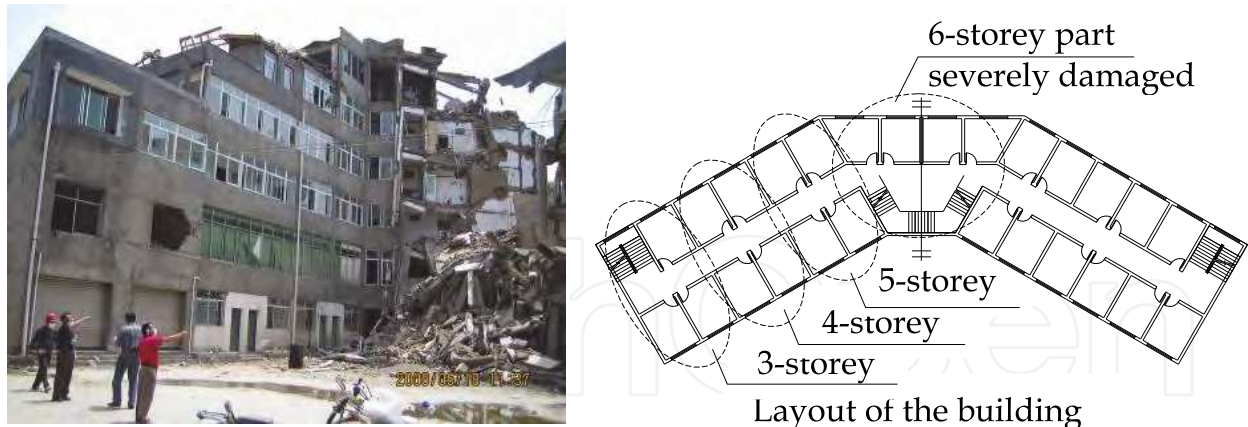

Fig. 7. Severe damage of masonry buildings with elevation irregularity

3. Discussion on the current seismic design method

3.1 Conceptual design

In order to get better seismic performance, the conceptual design is always very important to achieve besides the seismic analysis, especially in the early stage of architectural scheme. The current seismic code GB50011-2010 stipulates regulations for seismic conceptual design in detail. The consensus is reached by the engineering community that strictly following the seismic conceptual requirement should perform better seismic performance and at least minimize the possibility of the structural collapse (Wang, 2008; Zhang et al., 2008; Ren et al., 2008). The main key points for seismic conceptual design are emphasized here.

3.1.1 Structural regularity

Reasonable architecture arrangement may play an important role in the seismic conceptual design, with emphasis on the simplicity and symmetry in plan and elevation for uniform stiffness distribution of structures. Detailed description for regularity is given in the code.

More attention to enhance the structural ductility should be paid to the irregular structures if the seismic joint is not feasible to set, although separating the irregular structure into regular parts by seismic joint is a simple and good way in usual condition. Try to avoid the structural system of one bay transverse bearing wall with outside corridor supported by the cantilever beam.

3.1.2 Structural integrity

In order to get the largest possible number of redundancies subjected to earthquake action, structures should be fully integrated by structural members. Good structural integrity will guarantee the good seismic performance of structures.

The measure for structural integrity of masonry buildings should be the reinforced concrete members, such as tie beam, column and cast-in-site slab. The enhancement of the small size masonry wall segments for seismic protection is very important, as these segments are proved to be the weak parts subjected to earthquake in practice. The valid connection between the nonstructural components and the main structure should also be set properly.

3.2 Shear strength check

In the current seismic design code, only the shear strength check under minor earthquake is stipulated for seismic design analysis of masonry buildings.

The seismic shear capacity is contributed not only by the masonry wall segment but also by reinforced concrete member. It is checked by

$$V \leq R = \frac{1}{\gamma_{RE}} \left[\eta_c f_{VE} A + \xi f_t A_c + 0.08 f_y A_s \right] \quad (1)$$

In Equation (1), V is the shear force on the wall, R is the structural resistance, γ_{RE} is the seismic adjusting factor which is taken as 1 for bearing wall and 0.75 for self-bearing wall, η_c is the confined factor of wall which is usually taken as 1, f_{VE} is the design value for seismic shear strength of wall, A is the net cross area of the wall, ξ is the participation factor of reinforced concrete tie column in the middle which is taken as 0.4 or 0.5 by the number of tie column, f_t and A_c is the design tensile strength of concrete and the cross area of the tie column in middle, f_y and A_s is the design tensile strength and the total area of reinforcements of tie column in middle.

It should be mentioned here that the design value of the shear strength f_{VE} is got by the primary design value of shear strength f_V and the normal stress influence factor ξ_N , i.e.

$$f_{VE} = \xi_N f_V \quad (2)$$

The normal stress influence factor is determined by the pressure of the cross section corresponding to the gravity load. It is in the range of 1.0 to 4.8. The beneficial influence of normal stress on the shear strength is caused by the friction in the wall.

For convenience, the strength check parameter, which is defined as the structural resistance divided by the shear force, is set for shear strength check for the wall segment. Satisfactory result means the strength check parameter is no less than 1 as

$$SI = \frac{R}{V} \geq 1 \quad (3)$$

3.3 Introspection on the design analysis

The engineering practice showed that strength and deformation are two important factors to evaluate the structural performance. The deformation check is valuable to proceed. The elastic deformation analysis is quite helpful to find some seismic weak parts, such as the torsional irregularity, discontinuous displacement. And the elasto-plastic deformation check can directly verify the structural performance under major earthquake action.

The seismic design of masonry structure is dominated by the shear strength check under minor earthquake. As neither elastic nor elasto-plastic deformation check is involved, it is somewhat questionable to guarantee the collapse resistant capacity under major earthquake (Ren, Weng & Lu, 2008).

1. The investigated seismic damage shows the two way relationship between shear strength and axial strength of the wall. It is different from the theoretical assumption in the current design code that only the shear strength is affected by the axial strength. Once the shear failure happened, the mortar will break and have crack on it, which means that the axial strength will decrease. For the difference of masonry block or mortar and the influence of

construction quality, it is difficult to get the unified model for elasto-plastic deformation analysis. As no convincing progress in the elasto-plastic analysis of masonry structure, the current strength check method should be improved.

2. In practice, the structural ductility is proved to be the key for the collapse-resistant capacity of masonry buildings under the major earthquake. As the ductility of masonry structure is about 1-3, which is less than the normal range as 3-5 and 5-10 for the ductility of reinforced concrete structure and steel structure, the masonry structure is more like the brittle structure. In usually condition, the major earthquake action is about 4.5 to 6.3 times the minor earthquake action. If the strength check parameter is close to 1, which means not many margins for strength, severe damage and even collapse will happen on the structure. It is conflicted with the demand of no collapse under the major earthquake and necessary for more margins of shear strength in the seismic design.
3. The seismic design code emphasizes on the design details such as tie columns and beams for better structural regularity and integrity. Although the shear strength check method in current code can take these factors into consideration, no quantitative index can be got to evaluate the collapse resistant capacity under major earthquake action. To process the shear strength with the demand of deformation capacity may be the feasible way to evaluate the collapse resistant capacity of masonry structure.
4. The earthquake action on the structure is in any arbitrary direction. The earthquake damage shows that once the failure or partial failure of the wall happens in one direction, the wall will easily be broken in another direction due to the out-of-plan stability problem. Hence it is important to keep uniform seismic capacity in two directions. In usual conditions, the door and window will bring very different seismic capacity in two directions. These wall segments near the door and windows are usually the weak parts of the structure. The ratio of seismic capacity in two directions should be limited to a certain value.

4. Analysis of a severely damaged building

A typical severely damaged 3-storey masonry school building is found in Qingchuan County (Ren & Tao, 2011). Typical damaged longitudinal and transverse walls in first storey are shown in Fig. 8. The detailed position of damaged walls is marked in the layout (Fig. 9). As the through cracks are on the load-bearing walls, the structural capacity of this building decreases remarkably. Specially mentioned here, the damaged wall segment in longitudinal direction is in a quite dangerous state as it may collapse or partially collapse in the strong after-shock.



Fig. 8. Through cracks on the longitudinal and transverse load-bearing wall

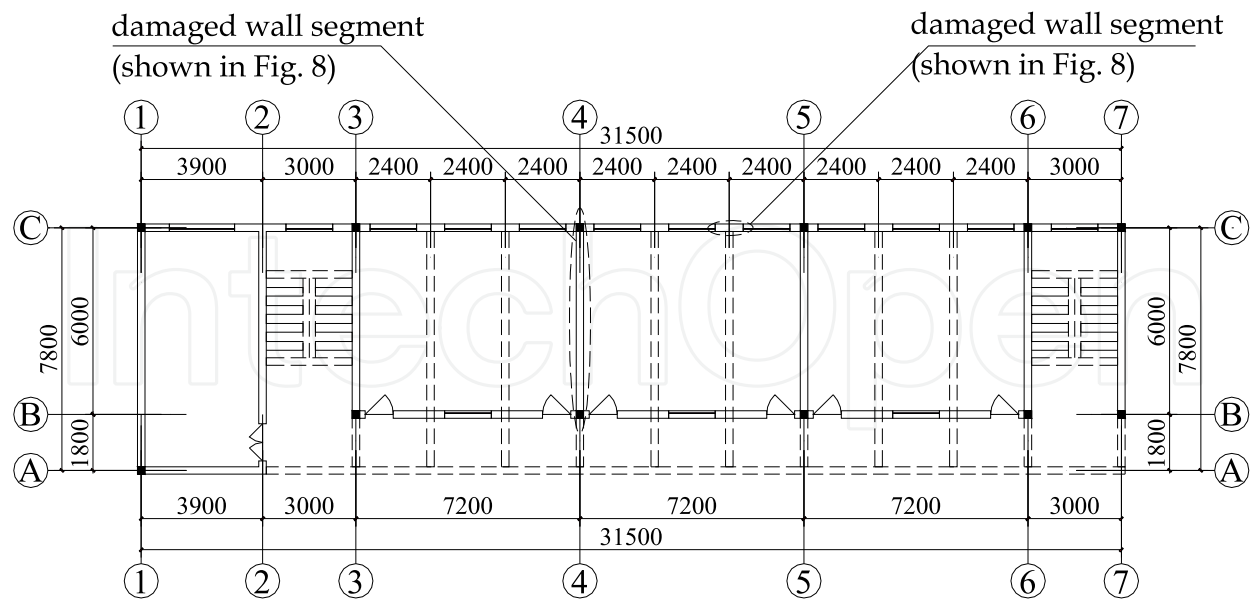

Fig. 9. Structural layout and the position of the severely damaged wall segments

4.1 Shear strength check under minor earthquake

An authorized design and analysis software PMCAD/PKPM is used for shear strength check of masonry structure (<http://www.pkpm.com.cn/>). In site, the mortar, the brick and the concrete are deduced to be M5, MU7.5 and C20. The wall thickness is 240mm. The storey height is 3.2m. The live and dead load on the floor is 2.0 and 4.0kN per square meter respectively.

Qualified result under minor earthquake is shown in Fig.10, as the strength check parameter is larger than 1. The damaged wall segments as shown in Fig. 9 are verified to be the most dangerous segment in transverse and longitudinal direction because of the smallest value of shear strength check parameter, which are 1.26 and 2.19 respectively.

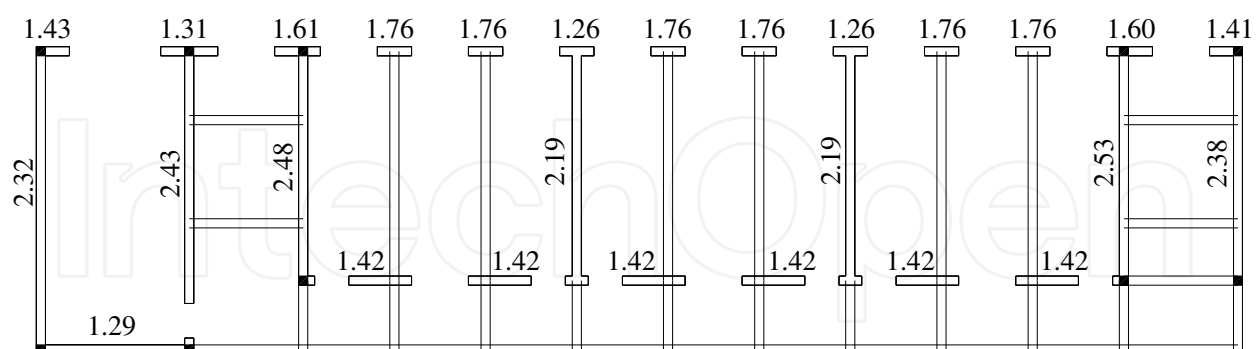

Fig. 10. Shear strength check parameter of the bottom storey

4.2 Further analysis

Although satisfactory check for intensity 7 is found according to the current design code, why so severe damage happened on the wall segments? The poor ductility of the masonry structure is the main reason. Here give a simple explanation for it.

Assuming the masonry structures has an idealized curve for shear force V and storey drift Δ as shown in Fig. 11, line 1-2-3 means the elasto-plastic behaviour while line 1-2-4 represents

the elastic model. Here point 1, 2 indicate the design state and the yield state of the structure. Point 4 can be determined by point 1 multiplying the relative real earthquake, which is the ratio of the real earthquake action vs. the design earthquake action (or the minor earthquake action). The failure point 3 can be determined by the equal area of two shadowed region in Fig. 11. The deformation ratio of point 3 vs. point 2 is defined as the ductility.

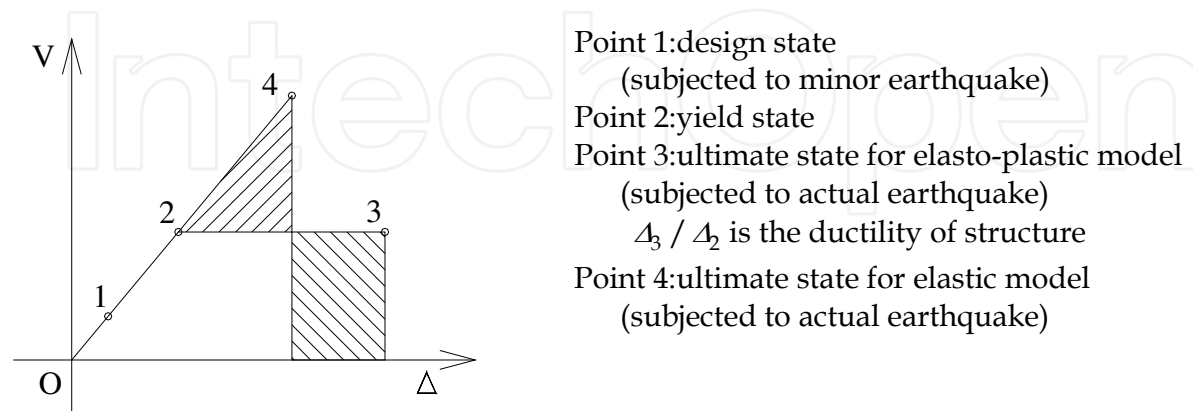

Fig. 11. Idealized curve of storey shear force vs. storey drift

When subjected to major earthquake, point 3 can be determined by the equal area of two shadowed regions in Fig. 11. The ratio of ultimate strength vs. design strength (V_3 / V_1 or V_2 / V_1) is usually about 2.5 to 3, an average value 2.7 is used here. For different fortification intensity, the minimum ductility can be got. From Table 2, it is found that the objective of no collapse under major earthquake may not be easily realized by the shear strength check under minor earthquake, as the ductility of masonry buildings is usually about 1-3.

Local fortification intensity	7	8	9
Relative major earthquake action	6.3	5.6	4.4
Minimum ductility required	3.22	2.65	1.83

Table 2. Minimum ductility required for different local fortification intensity

In usual condition, the ductility for this kind of masonry buildings with not many reinforced concrete members is no large than 2, the severe damage will happen in the condition of an earthquake action at the level of 5 to 6 times the minor earthquake action, which is smaller than the major earthquake action. This means the possibility of losing structural capacity under major earthquake action, which is about 6.3 times the design earthquake action (minor earthquake action) for fortification intensity 7. So it is not difficult to understand the severe damage on the load bearing walls, as shown in Fig. 8.

5. Suggestion for more margin

5.1 Improved shear strength check under minor earthquake

As the difficulty to make the elasto-plastic deformation check of masonry buildings, the feasible way for better seismic performance is to set more margin of shear strength under minor earthquake action. Enough shear resistant capacity may be got under the major earthquake action to prevent the loss on axial strength due to the horizontal crack.

For the improvement on Equation (3), the shear strength check under minor earthquake is suggested to satisfy

$$SI = \frac{R}{V} \geq \psi \quad (4)$$

Where, ψ is the modified limitation with consideration of the structural ductility. Equation (4) means higher requirement of structural capacity comparing with Equation (3). By the simplified model, the suggested parameter ψ can be got by the equal area of two shadowed regions in Fig. 11. It is seen that larger modified limitation should be set for the structure with smaller ductility.

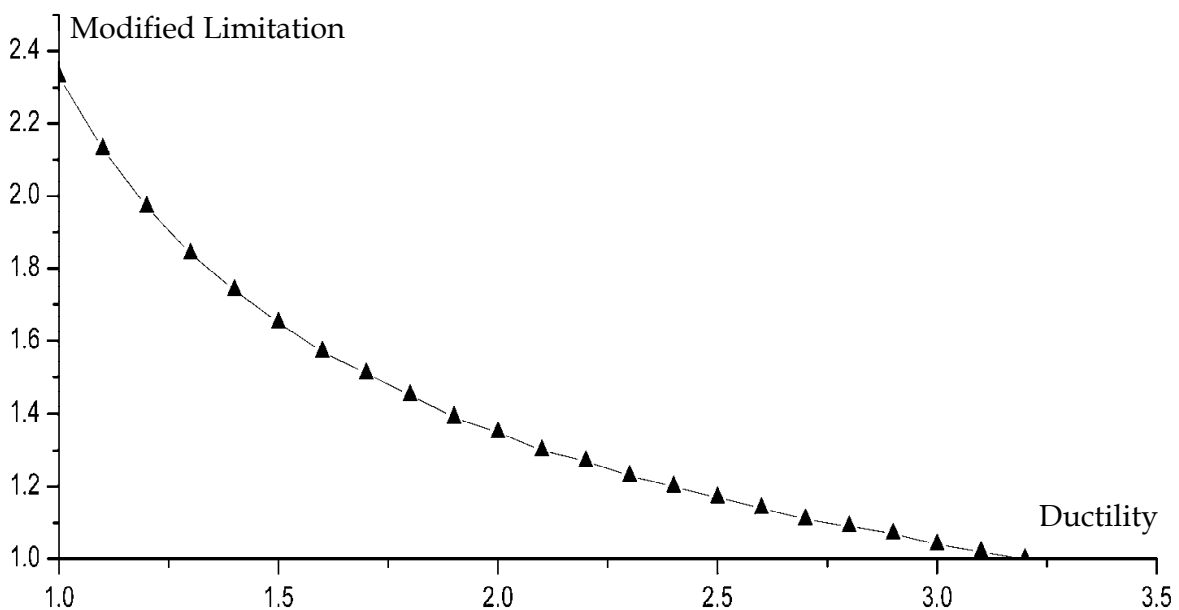

Fig. 12. Modified limitation of shear strength check for different ductility

In the meanwhile, to keep uniform seismic capacity in two directions is also very important for better seismic performance. The strength check parameter in two directions should be close to each other. Referring to regulations concerning the stiffness regularity in the current seismic design code, the ratio of the strength check parameter in two directions should be no less than 0.8. Considering the openings on the wall in the actual condition, some reinforced concrete members should be used to replace the small masonry wall segment. The structure is transformed to the composite structure of masonry and reinforced concrete, which is quite different from the ordinary masonry structure. Due to the large number and section size of the reinforced concrete member, the structure has more strength along with more ductility. The collapse resistant capacity of masonry buildings should be greatly improved.

5.2 Illustrative analysis

The damaged school building is illustrated here as an example here to demonstrate the authors' suggestion. As less tie columns are set, it is suggested to strengthen the structure in the longitudinal direction. As shown in Fig. 13, the small wall segments in axis B and C

should be substituted by reinforced concrete member with section 900mmX240mm, while the reinforced concrete tie-columns should be set in axis A at the outside corridor part. Similar structural analysis by PKPM software is done for strength check under minor earthquake. The main results are shown in Fig. 14 and Table 3. By comparison with Fig.10, it can be seen that the shear strength check ratio along transverse direction is raised from 2.19-2.53 to 2.68-2.80 and the parameter along longitudinal direction is raised from 1.26-1.76 to 1.74-3.07. The strengthened scheme can greatly enhance the seismic capacity.

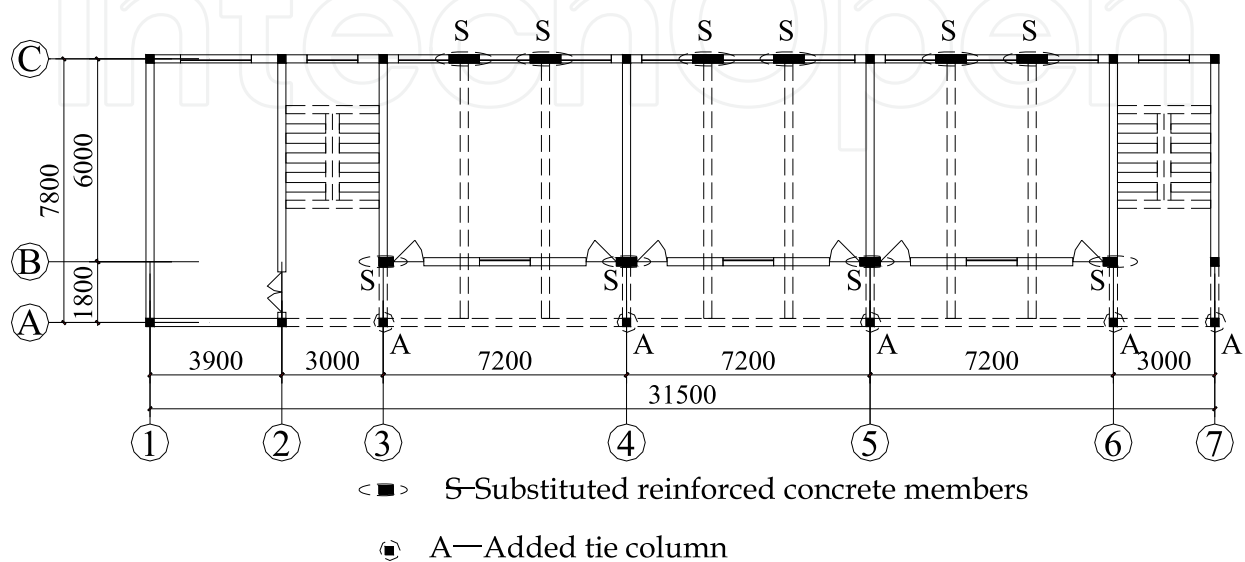

Fig. 13. Strengthened structural layout

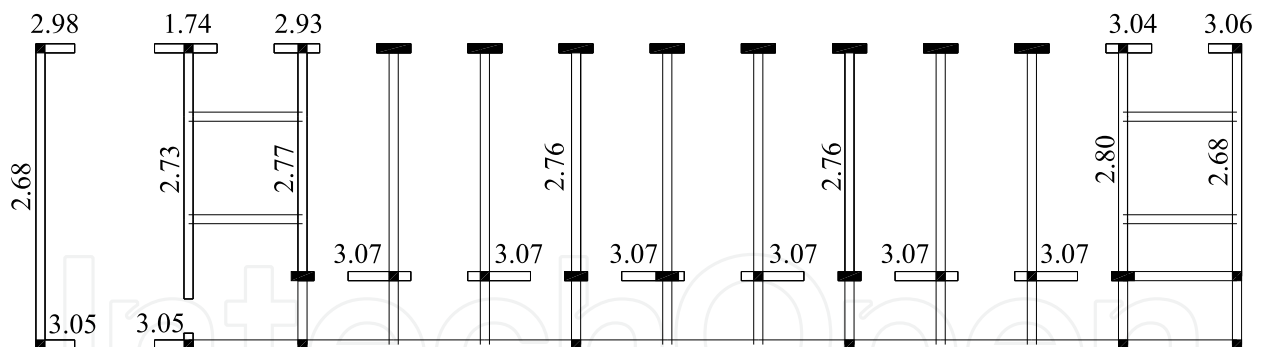

Fig. 14. The shear strength check parameter of the bottom storey of strengthened scheme

Item	Original	Strengthened
Average strength check parameter in transverse direction	2.37	2.74
Average strength check parameter in longitudinal direction	1.65	3.05
Ratio of average strength check parameter in two directions	0.70<0.8	0.89>0.80

Table 3. Average shear strength check parameter for the original and strengthened structure

5.3 Ductility evaluation

A simplified finite element plane model with two reinforced tie columns in the edge is used for ductility evaluation of the original and strengthened structure. It is used to simulate the longitudinal wall. The width of the wall is determined as 2.2m. The width of the reinforced concrete member is determined as 60mm and 300mm for. The area of the steel bar in the tie column is also determined as the average area of steel bar for the wall segment.

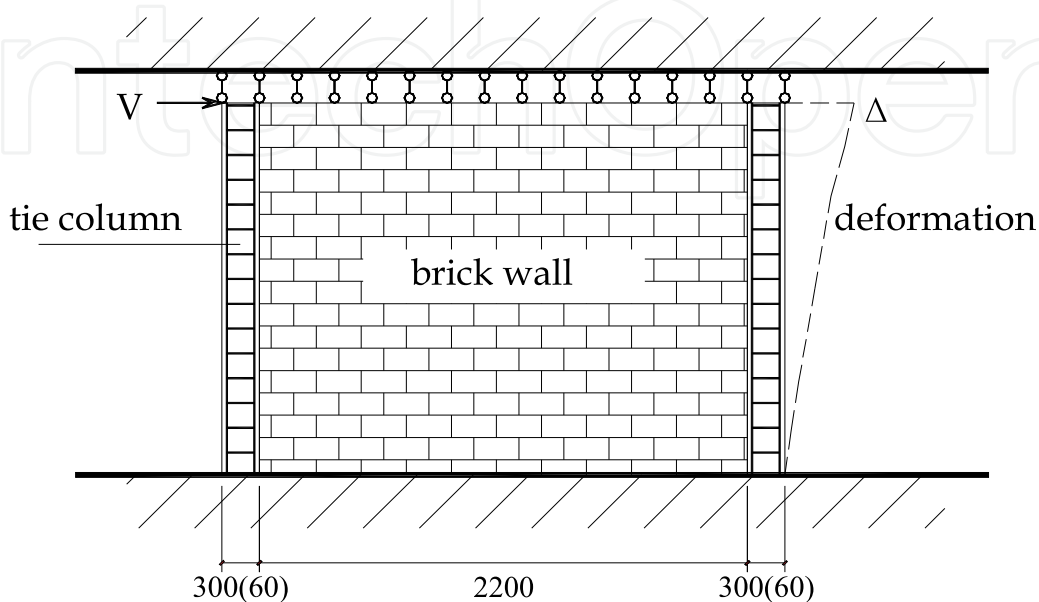

Fig. 15. Finite element model for ductility evaluation

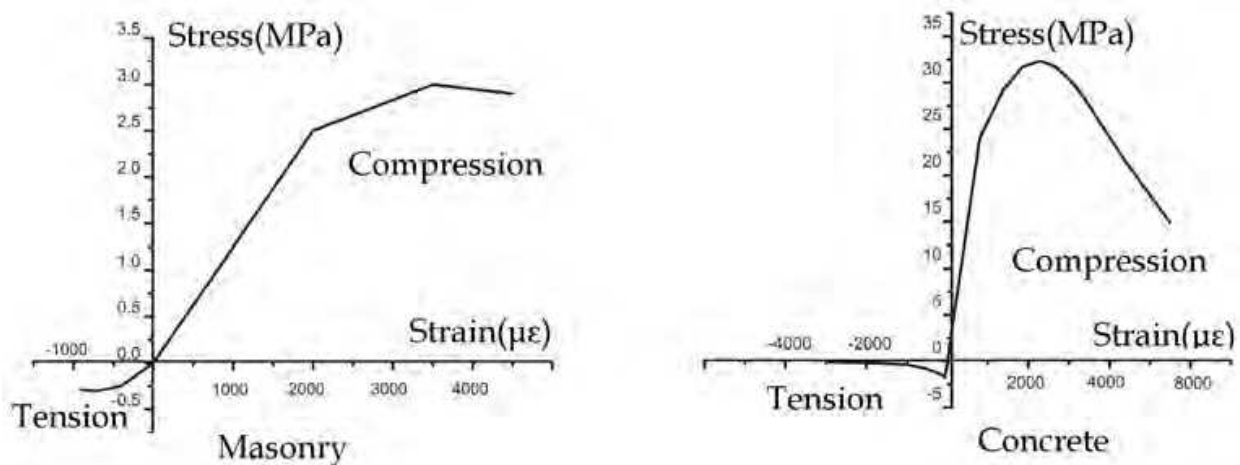

Fig. 16. Constitutive model for masonry and concrete

From the skeleton curve shown in Fig. 17, it is seen that the yield load and ultimate load of the strengthened structure is about twice the value of the original structure. Moreover, the ductility of the structure should be deduced from the hysteretic curve by the principle of no obvious decrease of the primary strength. The ductility is raised from 1.65 to 2.50. From Fig.12, the corresponding modified limitation is determined as 1.55 and 1.17 respectively. The original and the strengthened structure can not and can meet the authors' suggestion.

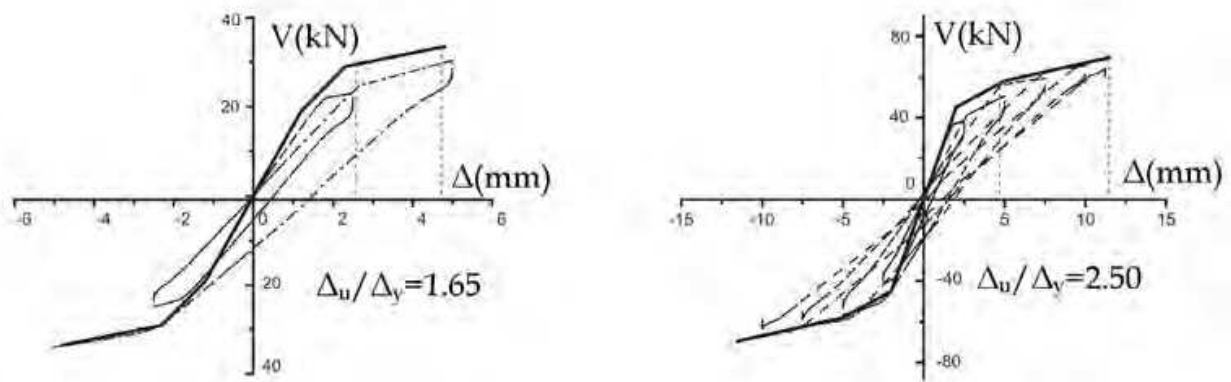

Fig. 17. Hysteretic curve and deduced skeleton curve for the different condition

Item	Original condition	Strengthened condition
Elastic stiffness(N/mm)	1.58×10^5	2.25×10^5
Yield displacement(mm)	1.20	2.00
Crack load(N)	1.90×10^5	4.5×10^5
Ultimate load(N)	3.10×10^5	6.95×10^5

Table 4. Main results for finite element analysis

6. Seismic retrofit by parcelled reinforced members

In 2001, a six storey masonry building in Shanghai was chosen as the first engineering case for the comprehensive transformation of residence. Duplex apartments with slope roof were added in the seventh floor. The ground floor residents moved to the corresponding apartment in the seventh floor. And the ground floor was used to be the space for public community. Elevators were also set. It is an active attempt to aim at the improvement on the residential function along with raising the level of seismic protection (Ren & Liu,2010).

6.1 Engineering background and strength check

The original structure was built in 1986. The building was found in a good condition by site test. The grade of masonry and mortar could meet the design demands of MU10 and M10, while the strength of concrete is deduced to be of grade C25.

The structure is a supported-on-transverse-wall system while the stair part is a supported-on-longitudinal-wall subsystem. Reinforced concrete ring beams are set in every floor, but no tie column is set. And prefabricated slab is used for floor. It is found that the potential capacity in vertical direction is exerted for the static strength demand of adding storey while the capacity of seismic resistance is insufficient, especially in longitudinal direction. For the difficulty to retrofit the structure by direct method, the strengthening strategy of load transferring is applied here for the improvement of poor seismic capacity. In Fig.18, the dashed lines represent the demolished walls while the black lines represent the parcelled reinforced concrete members.

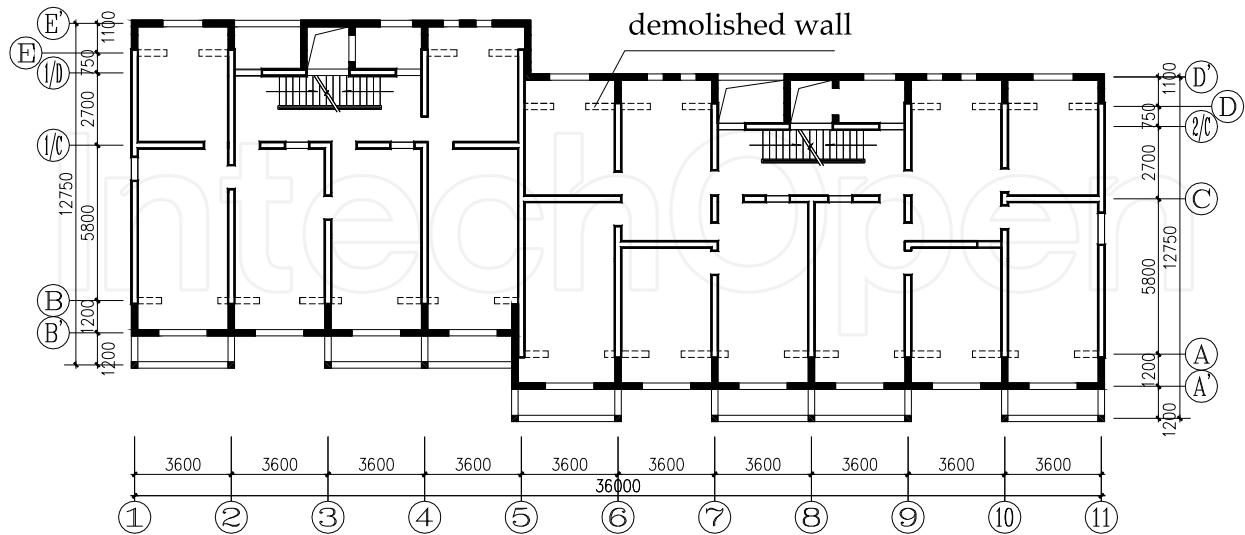

Fig. 18. Structural layout after comprehensive transformation

An eight storey model is established by PKPM software. The overhead floor is treated as the first storey in the model, and the added floor including the duplex part is treated as the eighth storey in the model with the load of one and half storey on it. Detailed results of shear strength check are got. The weakest structural member is located in the 2nd floor, which is shown in Fig. 19. The seismic performance is effectively enhanced.

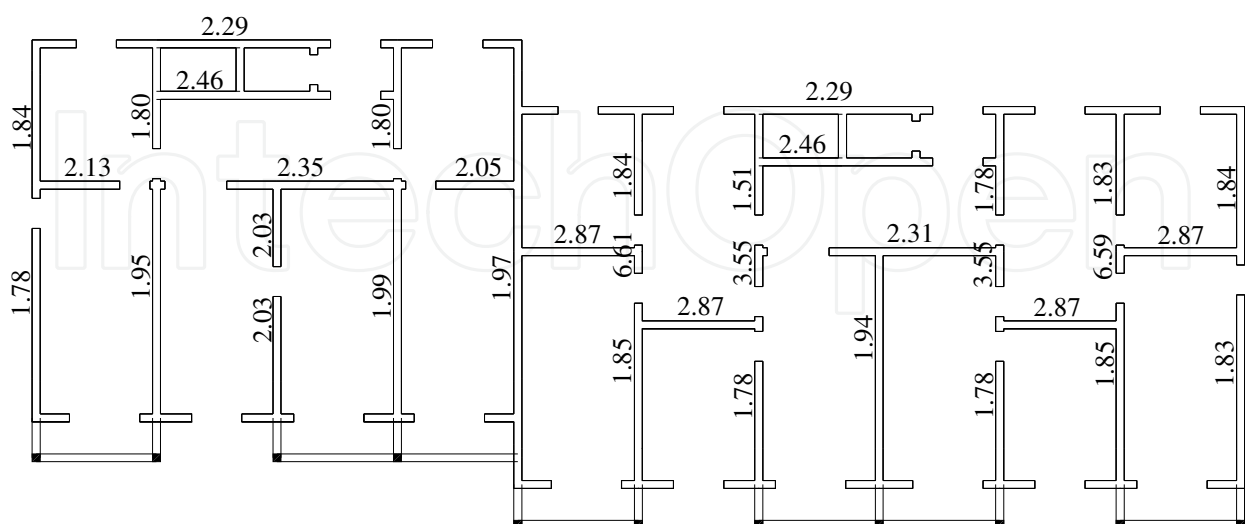

Fig. 19. The shear strength check parameter of the second storey

Moreover, the average parameter for the shear strength check under minor earthquake can be got. From Table 5, the satisfactory shear strength check can be found according to the authors' suggestion.

Model storey	Transverse direction	Longitudinal direction	Ratio of two directions
1	2.70	3.82	0.71
2	2.72	2.67	0.98
3	2.70	2.65	0.98
4	2.70	2.73	0.99
5	2.92	2.89	0.99
6	3.30	3.32	0.99
7	4.07	4.18	0.97
8	7.80	8.41	0.93

Table 5. The average shear strength check parameter under minor earthquake

Using the SATWE/PKPM program for further analysis under minor earthquake, the lateral storey stiffness can be got. (<http://www.pkpm.com.cn>). For comparison, another eight storey masonry model without the outside reinforced concrete walls is also established. The longitudinal analytical results are summarized in Table 6. Making comparison between the storey stiffness with and without reinforced concrete walls, the proportion of RC (reinforced concrete) part stiffness is got. It is seen that the earthquake action on the masonry part is greatly reduced. The first 3 natural modes are longitudinal, horizontal and torsional modes, and the corresponding periods are 0.46s, 0.35s, 0.30s. For the little influence of the mode of torsion, the analysis of longitudinal and transverse directions could be made separately. The largest storey drift is 1/2691, which is in fourth model storey or the third storey of actual structure.

Model storey	Masonry stiffness (kN/m)	Storey stiffness (kN/m)	Proportion of RC part stiffness	Storey drift
1	1.56×10^7	1.39×10^8	88.7%	<1/9999
2	1.19×10^6	5.09×10^6	76.6%	1/4474
3	8.61×10^5	3.45×10^6	75.0%	1/2946
4	7.54×10^5	3.00×10^6	74.8%	1/2691
5	6.93×10^5	2.76×10^6	74.9%	1/2780
6	6.47×10^5	2.61×10^6	75.3%	1/3174
7	6.06×10^5	2.52×10^6	75.9%	1/4126
8	3.64×10^5	2.04×10^6	82.2%	1/10500

Table 6. Analytical results along the longitudinal direction

6.2 Lumped storey model for elasto-plastic analysis

For the status of more margins along transverse direction, the elasto-plastic analysis in longitudinal direction is done to verify the collapse resistant capacity under major earthquake.

The masonry part and RC (reinforced concrete) part of every storey are represented by two lumped joints connected by a rigid rod. The lumped storey model is shown in Fig. 20. As

stated before, the stress-strain relationship for masonry part is a multi-line curve while it is a curve for reinforced concrete part. Here the proposed skeleton curves for the masonry and reinforced concrete part are demonstrated in Fig. 20.

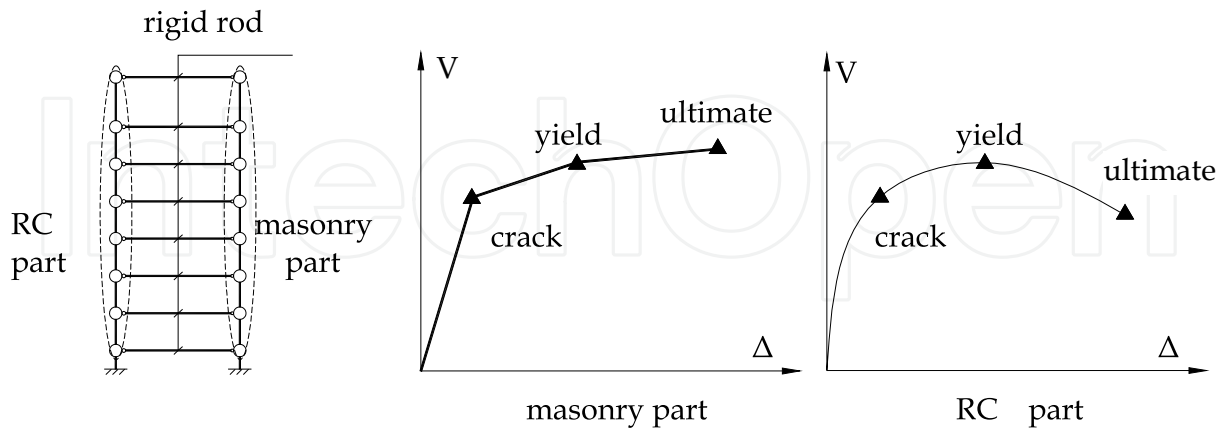

Fig. 20. Lumped storey model and proposed skeleton curve for two parts

From the past work carried out mainly by shaking table test and static push test (Zhu et al. 1980,1983; Xia, et al.,1989; Tomazevic, et al. 1996,1997; Benedett, et al. 1998,2009;Weng et al. 2002; Hori, et al. 2006;), three key points in the curve are denoted as primary crack, yield and ultimate. Although reaching the state of ultimate usually does not mean the complete failure of the structure, the descending stage from the ultimate state to the complete failure state is remarkably different from each other and usually neglected in the analysis. The values of storey drift of three key points are 1/1200, 1/500, 1/250, while the three key points' shear forces are 50%, 90%, 100% of the ultimate shear force. Detailed parameters for the skeleton curve will be gotten by the elastic storey stiffness resulted in the SATWE/PKPM analysis.

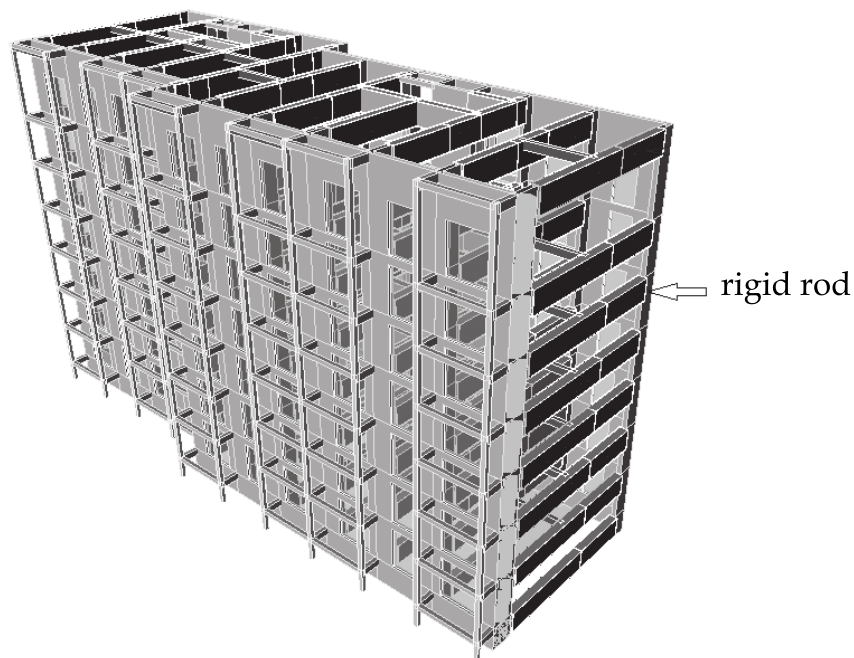

Fig. 21. Equivalent structure model for the analysis of skeleton curve of the RC part

An equivalent the PMCAD/PKPM model is established for the deduced skeleton curve of reinforced concrete part by the EPDA/PKPM software (<http://ww.pkpm.com.cn>). The masonry members are treated as the rigid rods with lumped mass on the model, which is marked as dark beam in Fig.21. The dynamic characteristic of this equivalent model is proved to be nearly the same as the actual structural model. In order to fit the actual case, the skeleton curve will be described as symmetric curve artificially. The three key points as crack point, yield point and ultimate point can be determined by the characteristics as obvious decrease in stiffness, stiffness degrading and the maximum deformation. The results are summarized in Table 7.

Model storey	Crack deformation (mm)	Crack load (kN)	Yield deformation (mm)	Yield load (kN)	Ultimate deformation (mm)	Ultimate load (kN)
1	0.14	1.4×10^4	0.5	2.2×10^4	0.7	2.4×10^4
2	2.0	1.5×10^4	11.0	2.2×10^4	18.0	2.4×10^4
3	2.8	1.5×10^4	7.5	2.0×10^4	11.0	1.6×10^4
4	3.2	1.4×10^4	7.5	1.8×10^4	10.0	1.4×10^4
5	3.0	1.2×10^4	8.0	1.5×10^4	10.0	1.3×10^4
6	3.2	1.5×10^4	7.0	1.3×10^4	11.0	1.0×10^4
7	2.2	8.0×10^3	7.0	9.0×10^3	10.0	7.0×10^3
8	2.0	4.4×10^3	5.5	5.5×10^3	10.0	4.2×10^3

Table 7. Key parameters for skeleton curve of reinforced concrete part

The lumped storey model has similar structural characteristics of the space model by PKPM software. The first vibration mode is of the first grade transversal vibration mode with natural period 0.44s, while the result of space structural model is 0.45s. And the story drift by the method of earthquake spectrum for Shanghai region (maximum horizontal influence coefficient 0.08) is quite close to the results by PKPM software, which is shown in column "response spectrum" of Table 8.

6.3 Elasto-plastic analysis under major earthquake

Two artificial records and a natural record are used as the ground acceleration input for the lumped storey model. The peak acceleration is 220 cm/s^2 . The response spectrum for the input seismic record and the design spectrum for Shanghai code are also shown in Fig.22. The symbol A-1, A-2 and N-1 in the following paragraphs represent the condition of two artificial seismic records and the natural seismic record.

The storey drift in different conditions is summarized in Table 8. The data in column "A-1", "A-2" and "N-1" is the elasto-plastic storey drift under three input ground acceleration. The data in column "average" is the average storey drift under three records. The data in column "response spectrum" is the elastic storey drift under minor earthquake action. Using the ratio of average storey drift divided by the elastic storey drift under major earthquake action, which the data in column "response spectrum" multiply 6.3, the amplifying factor for storey drift is listed in the last column of Table 8.

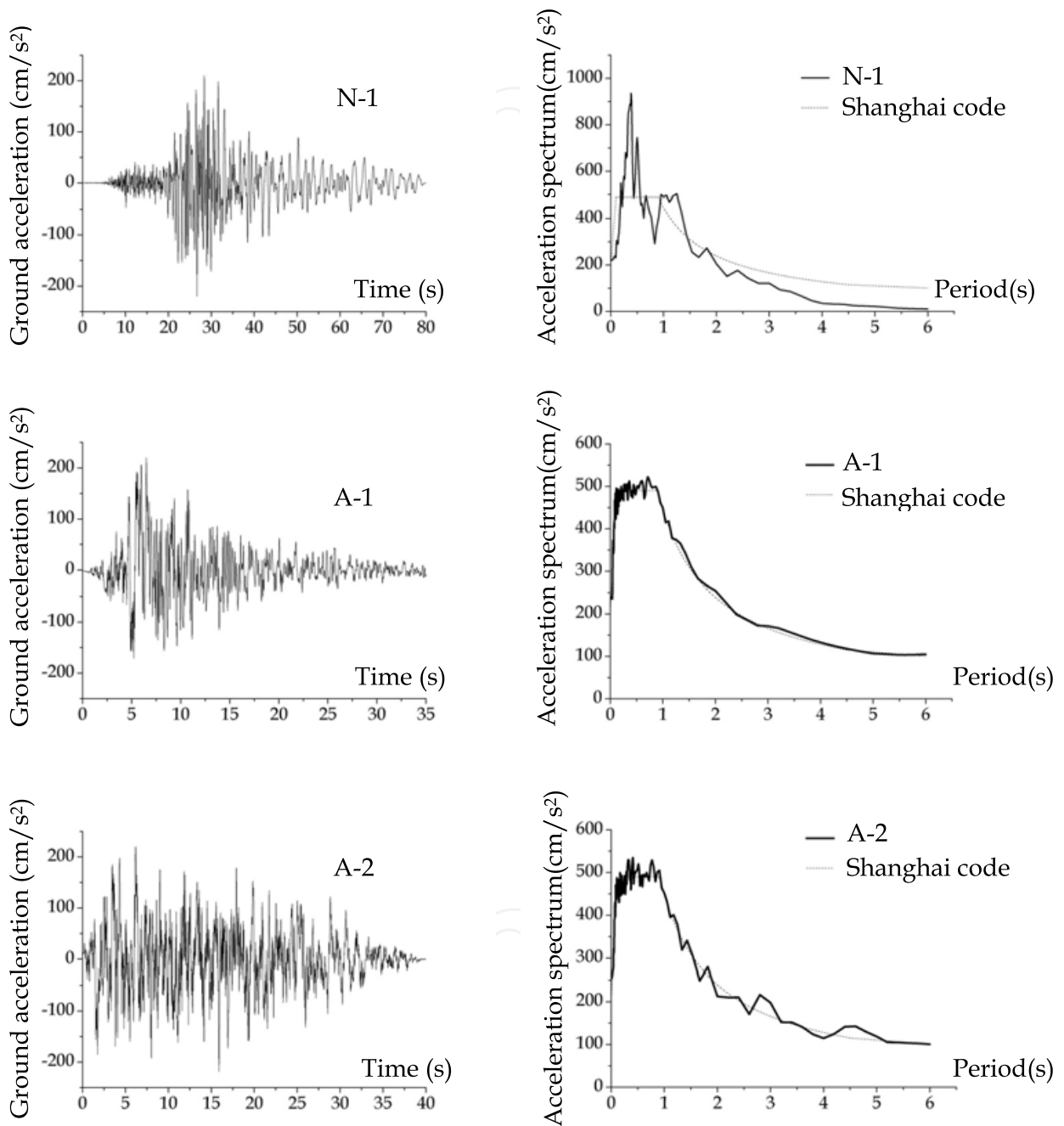

Fig. 22. Input ground acceleration and the response spectrum

Model storey	A-1	A-2	N-1	Average	Response spectrum	Amplifying factor for storey drift
1	1/6292	1/5450	1/4846	1/5467	1/51395	1.12
2	1/572	1/418	1/322	1/414	1/4071	1.20
3	1/511	1/433	1/311	1/401	1/3141	1.11
4	1/453	1/399	1/304	1/375	1/2812	1.23
5	1/427	1/372	1/284	1/351	1/2919	1.34
6	1/491	1/449	1/407	1/446	1/2979	1.06
7	1/660	1/633	1/478	1/578	1/4000	1.10
8	1/579	1/676	1/509	1/580	1/3784	1.03

Table 8. Elasto-plastic storey drift, elastic storey drift and the amplifying factor

From Table 8, it is seen that the strengthened structure can satisfy the demand of no collapse under major earthquake as the maximum storey drift is less than 1/250, which is the drift of ultimate point of masonry part. It is shown that the fourth and fifth storey have more plastic deformation than other storeys for the relative large values of amplifying factor for storey drift. The whole degree of structural plasticity is not very large. Moreover, the structural response under natural record is large than the response in artificial records due to the resonant period near the structural period, which can be found on its curve of response spectrum in Fig. 22.

The distribution of storey shear can also be obtained. Table 9 is the result of the proportion of storey shear on the reinforced concrete walls. The column "A-1", "A-2", and "N-1" is the proportion under three input ground acceleration, while the last column represents the average data of storey shear proportion. It is seen that the values are about 84%~90% and larger than the corresponding values in elastic range. This means that parcelled reinforced concrete walls contribute much more strength in plastic stage than in elastic stage. And the small changes in the condition of A-1, A-2 and N-1 demonstrate the re-distribution of storey shear in the plastic range.

Model storey	A-1	A-2	N-1	Average
1	86.2%	89.7%	86.9%	87.6%
2	86.0%	86.0%	86.1%	86.0%
3	86.2%	86.2%	86.1%	86.2%
4	85.7%	85.1%	85.4%	85.4%
5	85.3%	85.3%	85.2%	85.3%
6	84.1%	84.3%	84.3%	84.2%
7	85.7%	85.7%	85.7%	85.7%
8	85.4%	85.1%	86.2%	85.6%

Table 9. Proportion of storey shear distribution for reinforced concrete part

Although the earthquake action on the masonry part is limited after the adding of reinforced concrete walls, the masonry part is still the key for satisfying the demand of no collapse under major earthquake.

7. Conclusion

The discussion of the seismic performance of masonry building is presented here. The collapse-resistant capacity under major earthquake action is somewhat questionable according to the current design code. It is of great importance for better structure performance subjected to major earthquake. For the purpose of “no failure under minor earthquake, repairable damage under moderate earthquake and no collapse under major earthquake”, the structural ductility should be improved. More shear strength margin along with structural regularity and integrity are suggested in order to get better seismic performance. The suggestion can be easily realized in the current design analysis procedure. Besides a typical damaged masonry building illustrated, a success engineering case of retrofitting existing masonry building by parcelled reinforced concrete members is also presented to proceed seismic design by the authors’ suggestion. The seismic retrofit by parcelled reinforced concrete member is quite effective for the increment of the strength and the enhancement of the ductility. As a lot of masonry buildings exist in China and will not be demolished in a short time, parcelling reinforced members is the feasible and practical way for better seismic performance of existing masonry buildings.

8. Acknowledgment

Financial support from Shanghai Natural Science Foundation (No. 09ZR1433400) is gratefully acknowledged.

9. References

- Benedett, D. Carydis, P. and Pezzoli, P. (1998), Shaking Table Test on 24 Simple Masonry Buildings, *Earthquake Engineering and Structural Dynamics*, Vol.27, No.1, pp. 67-90
- Benedett, D. Carydis, P. and Pezzoli, P. (2009), Cyclic Behavior of Combined and Confined Masonry Walls, *Engineering Structures*, Vol.38, No.1, pp. 240-259
- Bruneau, M. (1994) State-of-the-art Report on Seismic Performance of Unreinforced Masonry Building. *Journal of Structural Engineering*, ASCE, Vol. 120, No.1, pp.230-251.
- Hori, N. Inoue, N. Purushotam, D. and Kobayashi, T. (2006), Experimental and Analytical Studies on Earthquake Resistant Behavior of Confined Concrete Block Masonry Structures, *Earthquake Engineering and Structural Dynamics*, Vol.35, No.1, pp.1699-1719
- Housner, G. W. and Xie, L. L. ed. (2002), *The Great Tangshan Earthquake of 1976*, Technical Report EERL 2002.001. California Institute of Technology, Pasadena, California.
- <http://www.pkpm.com.cn/>

- Liu, X. H., Zhang H.X.(1981) A Study of Aseismic Characteristics of Masonry Buildings with Reinforced Concrete Tie-columns , *Journal of Building Structures*, Vol. 2,No.6,pp.47-55. (in Chinese)
- Lu, X.L. and Ren, X.S.(2008), Site Urgent Structural Assessment of Buildings in Earthquake-hit Area of Sichuan and Primary Analysis on Earthquake Damages, *Proceedings of 14th World Conference on Earthquake Engineering*, No. S31-034, Beijing, China,Oct. 2008.
- National Standards of the People's Republic of China (2001). *Code for Design of Masonry Structures (GB 50003-2001) (English version)*, Architecture & Building Press. Beijing, China
- National Standards of the People's Republic of China (2001). *Code for Design of Concrete Structures (GB 50010-2001) (English version)*, China Architecture & Building Press. Beijing, China
- National Standards of the People's Republic of China (2001). *Code for Seismic Design of Buildings (GB 50011-2001) (English version)*, China Architecture & Building Press. Beijing, China
- Ren X. S., Liu C. (2010). Seismic Analysis of Multi-story Masonry Structure Parceled with Reinforced Concrete Wall [J], *Journal of Building Structures*,2010,31 (Supplementary Issue No.2): 334-339. (in Chinese)
- Ren X. S., Weng D.G., Lu X.L.(2008). Earthquake Damage of Masonry Buildings in Sichuan Province and Discussion on Seismic Design of Pimary and Middle School Buildings, *Earthquake Engineering and Retrofitting*, Vol.30,No.4,pp.71-76. (in Chinese)
- Ren X. S., Tao Y.F.(2011),Discussion on The Seismic Design Analysis Method of masonry Building,*Proceedings of International Conference on Structure and Building Material*, pp.3952-3957, Guangzhou,China, Jan. 2011
- Tomazevic, M. Lutman, M. and Petkovic, L. (1996), Seismic Behavior of Masonry Walls: Experimental Simulation, *Journal of Structural Engineering*, ASCE, Vol.122,No.9, pp.1040-1047.
- Tomazevic, M. and Klemenec, I. (1997), Seismic Behavior of Masonry Walls: Experimental Simulation, *Earthquake Engineering and Structural Dynamics*, Vol.26,No.1, pp.1059-1071
- Wang Y.Y. (2008). Lessons Learned from the "5.12" Wenchuan Earthquake: Evaluation of Earthquake Performance Objectives and the Importance of Seismic Conceptual Design Principles, *Earthquake Engineering and Engineering Vibration*, Vol.7,No.3,pp. 255-262.
- Weng D.G., Lu X.L., Ren X.S. et al. (2002), Experimental Study on Seismic Resistant Capacity of Masonry Walls, *Proceedings of 4th Multi-lateral Workshop on Development of Earthquake Technologies and their Integration for the Asia-Pacific Region(EQTAP)*,Tokyo, Japan,Sept. ,2002
- Xia J. Q., Huang Q. S.(1989), Model Test of Brick Masonry Buildings Strengthened with Reinforced Concrete Tie Columns, *Earthquake Engineering and Engineering Vibration*, Vol. 9, No.2,pp. 83-96. (in Chinese)

- Zhu B.L., Wu M.S., Jiang Z.X. (1980) , The Test Study on the Behavior of Masonry under the Reversed Load, *Journal of Tongji University*, No.2,pp.1-14. (in Chinese)
- Zhu B.L., Jiang Z.X., Wu M.S. (1983). Study on the Seismic Behavior of Masonry Buildings with Reinforced Concrete Tie-columns, *Journal of Tongji University*, No.1,pp.21-43. (in Chinese)

IntechOpen

IntechOpen

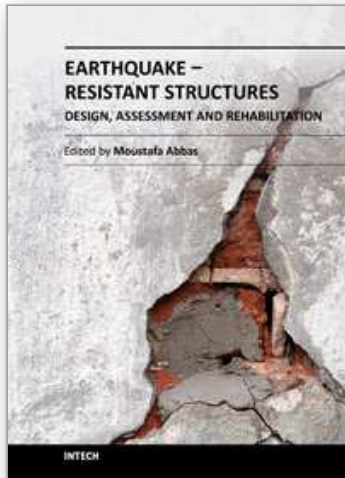

Earthquake-Resistant Structures - Design, Assessment and Rehabilitation

Edited by Prof. Abbas Moustafa

ISBN 978-953-51-0123-9

Hard cover, 524 pages

Publisher InTech

Published online 29, February, 2012

Published in print edition February, 2012

This book deals with earthquake-resistant structures, such as, buildings, bridges and liquid storage tanks. It contains twenty chapters covering several interesting research topics written by researchers and experts in the field of earthquake engineering. The book covers seismic-resistance design of masonry and reinforced concrete structures to be constructed as well as safety assessment, strengthening and rehabilitation of existing structures against earthquake loads. It also includes three chapters on electromagnetic sensing techniques for health assessment of structures, post earthquake assessment of steel buildings in fire environment and response of underground pipes to blast loads. The book provides the state-of-the-art on recent progress in earthquake-resistant structures. It should be useful to graduate students, researchers and practicing structural engineers.

How to reference

In order to correctly reference this scholarly work, feel free to copy and paste the following:

Xiaosong Ren, Pang Li, Chuang Liu and Bin Zhou (2012). Seismic Performance of Masonry Building, Earthquake-Resistant Structures - Design, Assessment and Rehabilitation, Prof. Abbas Moustafa (Ed.), ISBN: 978-953-51-0123-9, InTech, Available from: <http://www.intechopen.com/books/earthquake-resistant-structures-design-assessment-and-rehabilitation/seismic-performance-of-masonry-building>

INTECH
open science | open minds

InTech Europe

University Campus STeP Ri
Slavka Krautzeka 83/A
51000 Rijeka, Croatia
Phone: +385 (51) 770 447
Fax: +385 (51) 686 166
www.intechopen.com

InTech China

Unit 405, Office Block, Hotel Equatorial Shanghai
No.65, Yan An Road (West), Shanghai, 200040, China
中国上海市延安西路65号上海国际贵都大饭店办公楼405单元
Phone: +86-21-62489820
Fax: +86-21-62489821

© 2012 The Author(s). Licensee IntechOpen. This is an open access article distributed under the terms of the [Creative Commons Attribution 3.0 License](#), which permits unrestricted use, distribution, and reproduction in any medium, provided the original work is properly cited.

IntechOpen

IntechOpen