

We are IntechOpen, the world's leading publisher of Open Access books Built by scientists, for scientists

4,800

Open access books available

122,000

International authors and editors

135M

Downloads

Our authors are among the

154

Countries delivered to

TOP 1%

most cited scientists

12.2%

Contributors from top 500 universities

**WEB OF SCIENCE™**Selection of our books indexed in the Book Citation Index
in Web of Science™ Core Collection (BKCI)

Interested in publishing with us? Contact book.department@intechopen.com

Numbers displayed above are based on latest data collected.

For more information visit www.intechopen.com

Beneficial Effects of Fragrances in Beverages on Human Health

Hitoshi Aoshima
Yamaguchi University
Japan

1. Introduction

Foods contain proteins, carbohydrates, lipids and vitamins, among others, and are essential to human life. Beverages such as tea, coffee and liquor however are not essential to life, but are consumed in most countries around the world for mental and physical arousal, or rest and relaxation. Beverages usually contain a physiologically active component such as caffeine or ethanol, which acts mainly on neurotransmitter receptors in the brain, affects mental state, emotion and consciousness, and activates the reward system. It is thought in general that foods and beverages are appreciated for their taste, but the olfactory and somatic sensory systems are also important. The aromas in coffee, teas and liquors induce a desire to drink them. Aromas in beverages are especially important for mental relaxation.

Scent is not essential to human life, though pheromones are used by insects such as ants and bees to maintain social systems, and by some moths and animals to attract partners for copulation. However, fragrances in essential oils have been used as antibacterial compounds and perfumes since very early times. Various leaves have been used to wrap foods in order to protect them from bacteria and to add flavor. Recently, aromatherapy has become popular for mental relaxation, to combat the mental and physical stress due to busy modern lifestyles. Most people feel some emotional effect of aroma. The effects of aromatic compounds have not been clarified well from a scientific perspective, since they are quite weak compared with those of medical drugs.

Smells are thought to stimulate the olfactory system and produce signals that project to the olfactory bulb, where smell images are produced, analyzed and recognized by the brain (Buck, 2000). The olfactory bulb is part of the limbic system, along with the hippocampus, amygdala and hypothalamus. Olfactory stimulation is likely to have some effect on these organs. The hippocampus is important for memory establishment and recollection, while the amygdala is related to fear and stress responses. The hypothalamus controls the autonomic nervous, endocrine and immune system. Thus, fragrances have some effect on our mental state, mood or consciousness, through stimulation of the olfactory system (Shepherd, 2006). Reportedly, some fragrances enhanced sympathetic nervous activity and suppressed parasympathetic activity, while others have the opposite effect on autonomic nervous systems in rats.

Most fragrant substances are lipophilic, absorbed into blood through the skin, lungs, stomach and intestines, and enter the brain through the blood-brain barrier non-selectively.

Many fragrant compounds in essential oils and beverages potentiate the response of ionotropic γ -aminobutyric acid receptors (GABA_A receptors) caused by γ -aminobutyric acid (GABA), though they do not act as agonists. Since drugs such as benzodiazepine tranquilizers, barbiturate central nervous depressants, neuro-steroids, general anesthetics and ethanol, also potentiate the response of GABA_A receptors and induce their activity, fragrant compounds may also affect mental state, mood or consciousness, when incorporated into the brain (Aoshima & Hamamoto, 1999). The GABAergic nervous system projects to the hypothalamus, which controls the autonomic nervous, endocrine and immune systems and has some effect on the functions of these systems. For example, potentiation of the GABAergic nervous system suppresses the release of corticotropin-releasing hormone (CRH) from hypothalamus.

Fragrant compounds have psychological effects, stimulating the limbic system and triggering memories, a phenomenon known as the "Proust effect". Proust vividly described how a tea-soaked madeleine brought back powerful childhood memories (Chu & Downes, 2000). Smell is usually perceived together with visual, auditory or tactile stimulation. These sensory systems work synergistically to affect the mental and physical state of humans. For physical and mental health, it is essential to balance the sympathetic and parasympathetic nervous systems in the autonomic nervous system, since this balance is closely related to the endocrine and immune systems. Beverages can be used to balance these systems. Some fragrances in beverages play an important role in enhancing the parasympathetic nervous system and inducing physical and mental relaxation, while others enhance the sympathetic nervous system and induce mental arousal. Moreover, most fragrant compounds in beverages potentiate the response of GABA_A receptors, which induces a tranquilizing effect on the human mind. Thus, the fragrant compounds in beverages affect the homeostasis of mental and physical conditions together with active components such as caffeine and ethanol. Recent studies on the olfactory system are summarized in detail, and the physiological activities of aromatic (fragrant) compounds in beverages are discussed in this review.

2. Production of fragrant compounds

More than twenty thousand compounds, which have a molecular weight of less than about 400 and stimulate the olfactory system are estimated to be present in the world. Most fragrant compounds are produced by plants through two major pathways as described below. Beverages contain many fragrant compounds derived from raw materials. Liquors are produced from fruits, grains and sweet potatoes, teas such as green tea, oolong tea and black tea are produced from tea (*Camellia sinensis*) leaves, and coffee is produced from coffee (*Coffea arabica*) beans.

2.1 Fragrances from plants

Terpene compounds in essential oils are produced from isoprene (2-methyl-1,3-butadiene) derivatives in plants. Condensation of isopentenyl diphosphate (IPP) and dimethylallyl diphosphate (DMAPP) produces geranyl diphosphate. IPP is produced from mevalonate or deoxyxylulose phosphate, while DMAPP is produced from IPP by an isomerase. Isomerization, oxidation, cyclization and dephosphorization produce various monoterpenes. Then, sesquiterpene, diterpene, and sesterterpene are produced by the

addition of an isoprene residue from IPP (Dewick, 2002). Triterpene and tetraterpene are produced from the dimerization of sesquiterpenes and diterpenes, respectively.

The other pathway involves oxylipin. Leaf aldehyde ((*E*)-2-hexenal), leaf alcohol ((*Z*)-3-hexanol), and (*Z,Z*)-3,6-nonadienal are produced by the oxygenation of unsaturated fatty acids by lipoxygenase and their scission by lyase (Hatanaka, 1993). Jasmonic acid is produced from lipid hydroperoxide by enzymes such as allene oxide synthase (Matsui, 20066). The structural formulae of popular fragrant compounds produced through these two pathways are shown in Fig. 1.

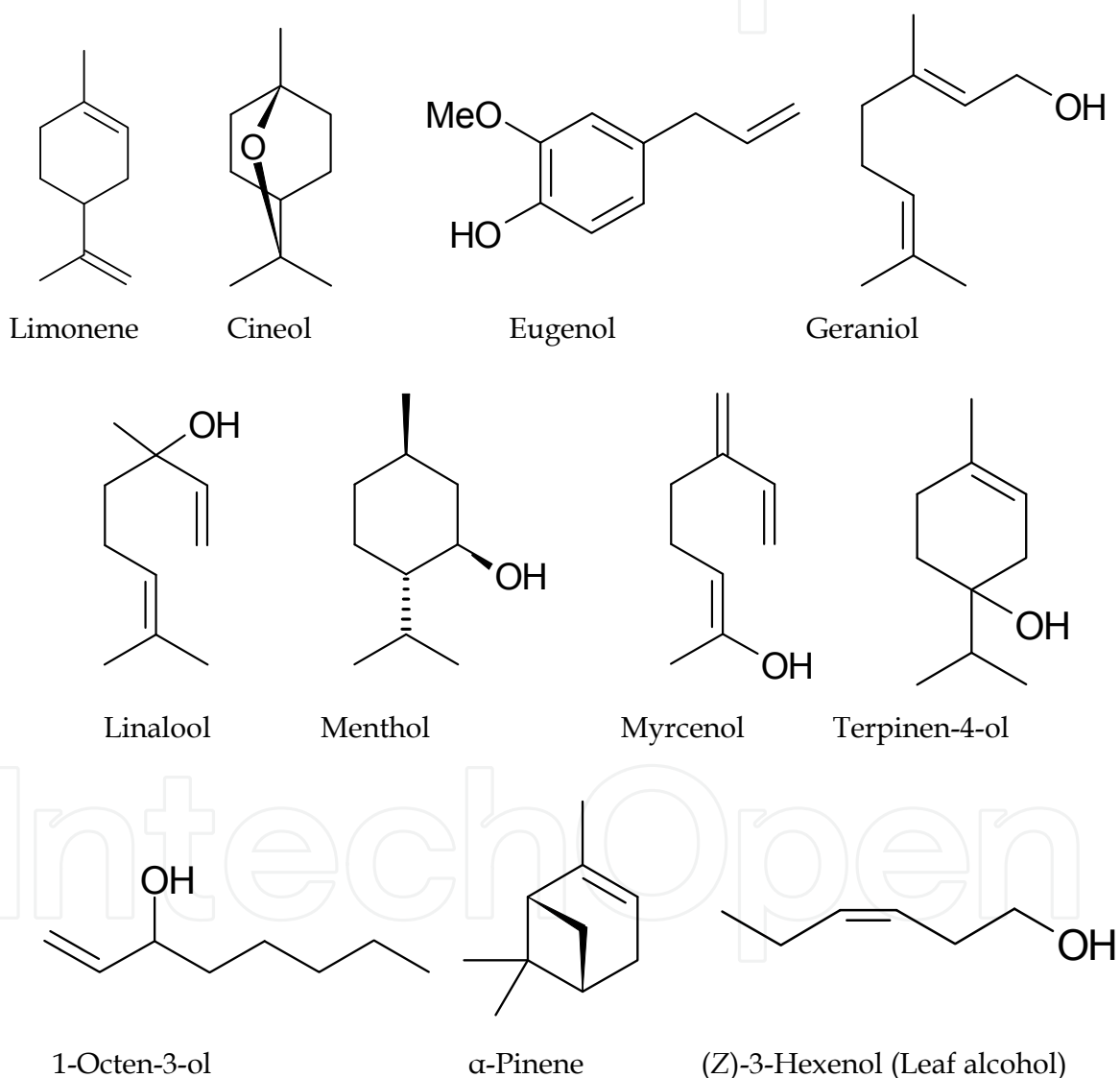

Fig. 1. Chemical structure of several popular fragrant compounds.

2.2 Fragrances in beverages

Many fragrant compounds in beverages origin from raw materials such as tea leaves, coffee beans, fruits or grains (Maase, 1991). Many fragrant compounds are also produced during

the processing of beverages (Maase, 1991). Not only ethanol, but also other alcohols such as *n*-propanol, *iso*-butanol and *iso*-amyl alcohol are produced during fermentation by yeast when liquors are made from fruits and grains. During the fermentation process, fusel aldehydes and carboxylic acids are also produced by the oxidation of fusel alcohols, and esters such as ethyl acetate and *iso*-amyl acetate are produced by condensation between the alcohols and carboxylic acids. Whiskey and red wines are stored in oak barrels for many years for aging, during which aromas (Fig. 2) and pigments move into the liquors from oak wood. Hops are added to the beer to give it a characteristic bitter taste and many fragrant compounds. Hops have floral fragrances such as linalool, geraniol and 1-octen-3-ol. Higher alcohols such as myrcenol and humulenol from myrcene and humulene in hops are produced during the boiling of sweet wort, the extract of the mixture of malt and hops. Liqueurs are produced from liquors by addition of various herbs, fruits or nuts, which contain many fragrant compounds.

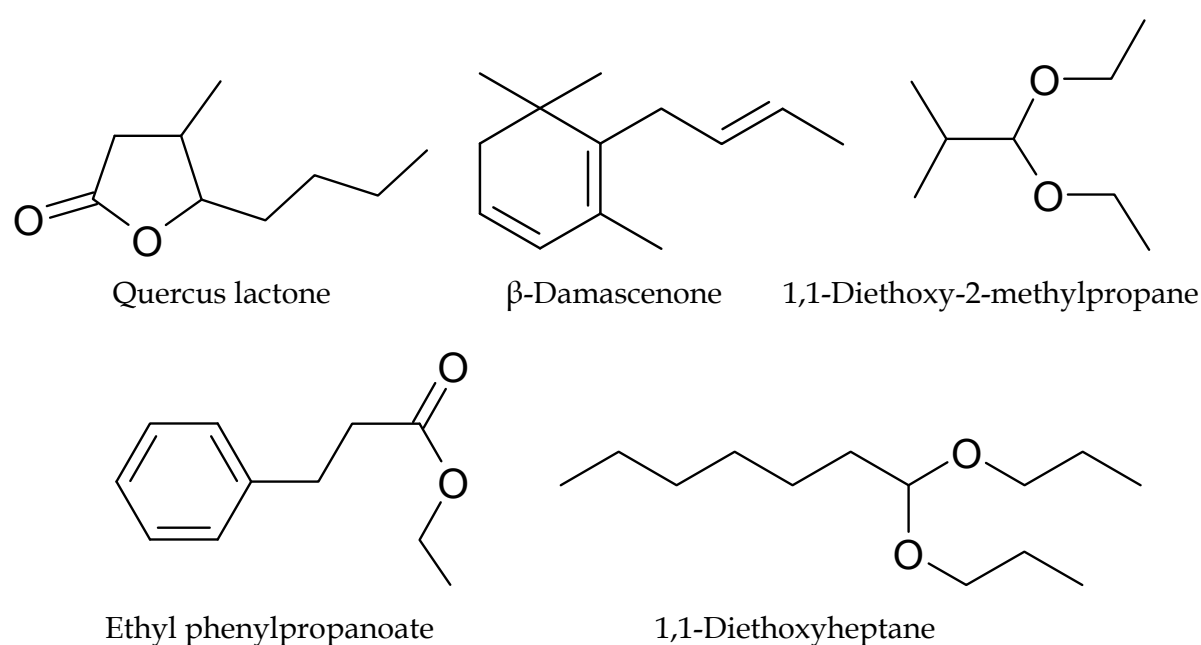

Fig. 2. Some fragrant compounds in whiskey (or whisky).

Green, oolong and black teas are produced from tea (*Camellia sinensis*) leaves, which contain caffeine as an active component, by heating, crumpling and drying (Maase, 1991). To produce green tea, tea leaves are heated first to stop the enzymatic reaction in tea leaves by applying hot steam or heating in a caldron, then crumpled and dried. Tea leaves are crumpled without destroying the cells in the production of oolong tea, while they are crumpled to destroy the cells in the production of black tea. During the crumpling, enzymes such as oxidases or polymerases of catechins and glucosidases of glycosides of fragrant compounds catalyze various reactions. The composition of fragrant substances, polyphenols and pigments in different teas changes and is dependent on the processing. Then these teas are heated and dried to produce oolong tea or black tea. Typical fragrant compounds in green tea and black tea are summarized in Table 1. Herbal teas are produced from herbs by drying and contain many fragrant components (Nagashima, 2010). Herbal teas do not usually contain bio-active compounds such as caffeine, but their aromatic substances may act on GABA_A receptors. It is thought that herbal teas induce mental relaxation through both

olfactory stimulation and potentiation of the response of GABA_A receptors. It has been also found that green tea polyphenol (-)-epigallocatechin gallate (EGCG) has anxiolytic-like effects by interacting with the GABA_A receptor (Vignes, et al., 2006).

Coffee is produced from coffee beans, which contain caffeine as an active component, by roasting and crushing. During roasting, phenol derivatives, which are smoky, spicy or burnt, are produced from thermal degradation of lignin. The following compounds are also produced during roasting and play an important role in determining the flavors of coffee (Table 2) (Maase, 1991). Furfural derivatives are produced by a caramelization of sugars and

Compound	Green tea	Black tea	Characteristic
<i>cis</i> -3-Hexen-1-ol	++	++	Green odor
Nerolidol	+++	+++	Woody, milky and deep odor
α -Cadinol	+++	NM	Woody, milky and deep odor
Benzyl alcohol	+++	++	Jasmine and ylang-ylang like odor
<i>cis</i> -Jasmone	+++	+++	Jasmine like odor
β -Ionone	+++	+++	Fragrant orange-colored olive like odor
Linalool	++	+++	Lavender and daphne like odor
Phenylethyl alcohol	+	++	Roselike odor
Geraniol	+	+++	Roselike odor
Indole	+++	NM	Floral odor at low concentration
Pyrrole	++	NM	Floral odor at low concentration

+: small amount, ++: middle amount, +++: large amount, NM: not determined. Amount of fragrant compounds in teas are expressed qualitatively, since they are very variable and depend on tea leaves and their processing.

Table 1. Fragrances in green and black tea. (Yamanishi, 1992)

Compound	Character
Limonene	Weak good odor
β -Myrcene	Pleasant odor
1-Octen-3-ol	Mushroom like odor
(E)-2-Nonenal	Green cucumber like odor
2-Methylbenzaldehyde	Plum like odor
Methyl phenyl acetate	Honey or jasmine like odor
4-Butanolide	Weak sweet odor
Maltol	Sweet caramel like odor
Phenol derivatives	Smoky, spicy and burnt odor
Furane, thiophen derivatives	Toasted, caramel-like and nutty burnt odor
Pyrrole derivatives	Caramel like odor
Oxazole derivatives	Natty, sweet and green odor
Pyridine derivatives	Green, bitter, roasted and burnt odor
Pyrazine derivatives	Sweet and toasted odor

Table 2. Fragrances in coffee beverages (Maase, 1991)

have a toasted penetrating odor and (or) caramel-like and nutty burnt flavor. Sulfur-containing furfural compounds are important to the flavor of roasted coffee. Thiophene, pyrrole, oxazole, thazole, pyridine and pyrazine derivatives also contribute to the complex and attractive flavors of coffee. Arabica coffees have better, milder and sweeter fragrances than Robusta ones.

3. Olfactory system

3.1 Olfactory system and smell images

The olfactory system has been studied extensively ever since Buck and Axel first reported the olfactory receptors (Buck & Axel, 1991), G protein-coupled receptors whose genes have seven trans-membrane domains. These receptors are thought to activate adenylate cyclase, increasing the cyclic adenosine monophosphate (cAMP) concentration. The family of olfactory receptors has about 1000 members in rodents, and 380 members in humans. The olfactory cell has only one type of olfactory receptor. Fragrant compounds bind to several olfactory receptors differing in affinity. The axons of about ten thousand sensory neurons in olfactory cells with the same species of receptors project to the same glomerulus in the olfactory bulb. The glomeruli are excited dependent on the concentration of the fragrant compounds and the affinity for the receptors. Thus, information on aromas received in the olfactory epithelium is converted to topological maps of activated glomeruli, *i.e.* smell images, which are analyzed and perceived by the brain (Fig. 3) (Buck, 2000; Shepherd, 2006). The existence of smell images was confirmed directly using high-resolution functional magnetic resonance imaging (fMRI) in mice (*Mus musculus*). A homologous chemical series such as aldehydes with different chain lengths elicits patterns that overlap but have different spatial patterns of activity in the glomerular layer of the olfactory bulb (Xu et al., 2003).

The smell images in the olfactory bulb are subjected to processing by the olfactory cortex and relayed to the primary olfactory cortex in the orbitofrontal cortex, a part of the prefrontal lobe, through mitral cells and the piriform (Fig. 3). The signals in the piriform are also relayed to the entorhinal cortex, hippocampus, amygdala, and hypothalamus in the limbic system. Since the olfactory perceptual system is closely linked to systems for learning, memory, emotion and reward, aromas have various effects on mental state, *i.e.* consciousness, emotion and instinct. Aromas also influence the autonomic nervous system, endocrine system and immune system, which are controlled by the hypothalamus (Julius & Katz, 2004).

It is important to clarify how the smell images in the olfactory bulb are interpreted in the brain. However, it is reported that stimulation of a specific glomerulus by an odor induces a specific behavior in fruitflies or mice, suggesting the presence of specific circuits from the olfactory cells, *i.e.* olfactory receptors to the brain.

3.2 Innate and learning pathways

The fruitfly (*Drosophila melanogaster*) exhibits robust and innate olfactory-based avoidance behavior in response to CO₂. Specialized neurons with Gr21a/Gr63a CO₂ receptors in the antenna and a dedicated neuronal circuit in the higher olfactory system mediate CO₂ detection and avoidance. Both 1-hexanol and 2,3-butanedione which are often emitted from bananas and yeasts inhibit the response of the CO₂ receptor, which allows fruitflies to find and eat their foods (Turner & Ray, 2009). Fruitflies are markedly attracted to food odors.

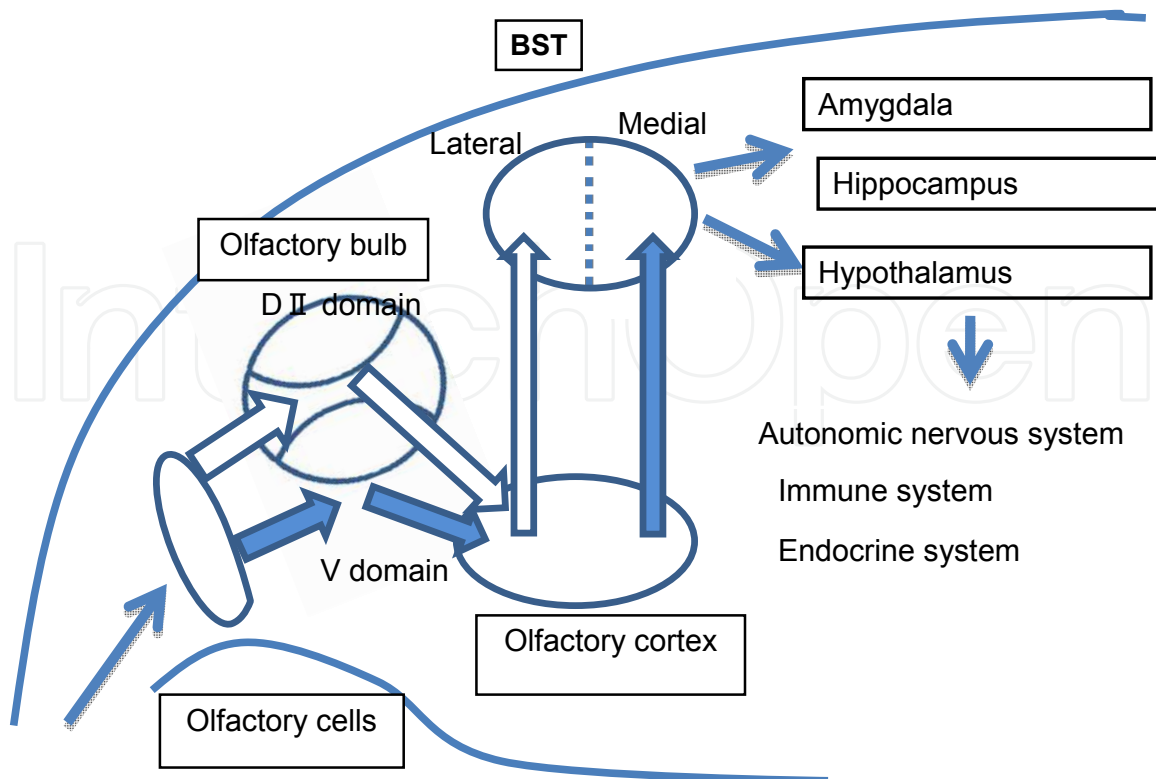

Fig. 3. Olfactory system and innate (gray arrays) and learning (white arrays) pathways. (Kobayakawa et al., 2007).

Semmelhack and Wang used genetic tools to dissect the contribution of each of six glomeruli activated by apple cider vinegar and found that an absence of activity in two glomeruli markedly reduced the attractive effect (Semmelhack & Wang, 2009). When each of these two glomeruli was selectively activated, the flies showed as robust an attraction to the vinegar as wild-type flies. A higher concentration of the vinegar excited an additional glomerulus and was less attractive to the flies. Activation of the extra glomerulus was necessary and sufficient to mediate the behavioral switch. These results indicate that individual glomeruli, rather than the overall pattern of activation (smell images), mediate the innate behavioral output of fruitflies.

Carey *et al.* expressed 72 odorant receptors of the mosquito *Anopheles gambiae* in mutant neurons of *Drosophila melanogaster* lacking endogenous odorant receptors, and characterized electrical responses to 110 chemically diverse odorants (Carey et al., 2010). The receptors of *A. gambiae* responded strongly to components of human odor and might aid in the process of human recognition. The odorants were differentially encoded by the two species in ways consistent with their ecological needs to find their foods.

Koyabakawa et al. (2007) generated mutant mice in which olfactory sensory neurons in a specific area of the olfactory epithelium are ablated by targeted expression of the diphtheria toxin gene. The mutant mice lacked innate responses to aversive odorants, even though they were capable of detecting them and could be conditioned for aversion with the remaining glomeruli. In mice, aversive information caused by trimethyl-thiazoline secreted from the anal gland of foxes was received in the olfactory bulb by separate sets of glomeruli, those dedicated to innate responses and those for learned responses. The aversive signals are transferred

through a dorsal domain for class II odorant receptors (D_{II} domain) in the olfactory bulb, the olfactory cortex, the medial aspect in the bed nucleus of the stria terminalis and hypothalamus (gray arrays), while the learned signals are transferred through a ventral domain for class II odorant receptors (V domain) in the olfactory bulb, the lateral division in the bed nucleus of the stria terminalis (white arrays) (Fig. 3). It is thought that humans have no pheromone, which affects the growth or behavior of creatures, since humans have no vomeronasal organ, which detects specifically pheromones and induces specific effects (Buck, 2000). However, humans may have innate olfactory circuits for dangerous compounds such as H_2S and NH_3 , which are present around active volcanoes or produced from rotten foods.

3.3 Orthonasal and retronasal stimulation

Smell is unique in having a dual nature, that is, it can sense signals originating outside (orthonasal) and inside (retronasal) the body (Shepherd, 2006). Orthonasal stimulation refers to sniffing in through the external nares of the nose to activate sensory cells in the olfactory epithelium. Good flavors attract people to beverages. Retronasal stimulation occurs during the ingestion of food and beverage, when volatile molecules released in the mouth are pumped, by movements of the mouth, from the back of the oral cavity up through the nasopharynx to the olfactory epithelium. This stimulation is especially important when foods are taken together with beverages such as tea and whiskey. The re-emergence of powerful childhood memories in response to a tea-soaked madeleine, so vividly described by Marcel Proust (Chu & Downes, 2000), would have occurred primarily through the retronasal pathway. It is likely that fragrant compounds in beverages are detected by the odor-reward association learning system, since humans feel better as they drink in part because of an addiction to caffeine or ethanol.

3.4 Adaptation and masking

Cilia in olfactory receptor cells produce electrical signals on the binding of aromatic compounds to olfactory receptors as shown in Fig. 4. It is thought that these receptors activate adenylate cyclase (\circ), increasing the cAMP concentration. The cAMP opens cyclic nucleotide-gated Ca^{2+} channels, causing the influx of Ca^{2+} into the cells and depolarization of the cell membrane. Then, Ca^{2+} opens Ca^{2+} -activated Cl^- channels and causes further membrane depolarization, since the olfactory cells have abnormal Cl^- concentrations between the inside and outside of the membrane, *i.e.*, almost equal Cl^- concentrations between the inside and outside. Thus the signals induced by aromas are amplified and produce action potentials in the cells. These action potentials are transferred to the glomeruli in the olfactory bulb.

Adaptation to odorants is thought to begin at the level of olfactory receptor cells, presumably through modulation of their transduction machinery. Kurahashi & Menini (1997) studied the adaptational mechanism in intact olfactory cells of newts by using a combination of odorants and caged cAMP photolysis which produces current responses. Odorant- and cAMP-induced responses showed the same adaptations in a Ca^{2+} -dependent manner, indicating that the adaptation occurs entirely downstream of the adenylate cyclase. The Ca^{2+} -activated Cl^- channels did not show adaptations when Ca^{2+} was applied to the cells by caged Ca^{2+} photolysis. Thus, the principal mechanism underlying odorant adaptation is actually modulation of the cAMP-gated channel by Ca^{2+} feedback, *i.e.*, a change in affinity of the channel for the ligand.

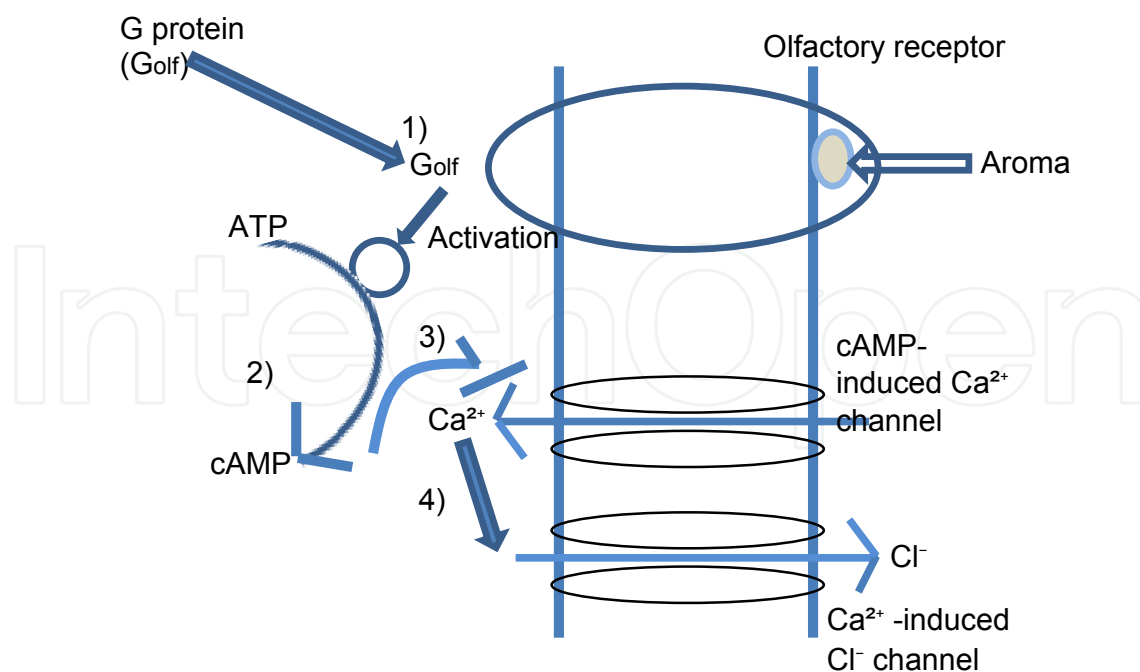

Fig. 4. Production of electrical signals in olfactory receptor cells (Takeuchi et al., 2009).

Other mechanisms of adaptation in the central nervous system were proposed by Linster et al. (2009), who showed that odor-specific adaptations in piriform neurons, mediated at least partially by synaptic adaptations between the olfactory bulb outputs and piriform cortex pyramidal cells, are highly odor specific, while those observed at the synaptic level are specific only to certain odors.

Olfactory masking has been used to erase unpleasant sensations by bad odorants. Takeuchi et al. (2009) measured the currents of both cAMP-gated Ca²⁺ channels and Ca²⁺-activated channels in the cilia of olfactory receptor cells by the photolysis of caged compounds, using the whole cell patch clamp method. They found that 16 odorants suppressed the response of the cAMP-gated Ca²⁺ channels with different sensitivities, but showed no effect on the response of the Ca²⁺-activated channels. Ringer's solution pre-exposed to odorant-containing air affected the cAMP-induced current of single cells. Using the same odorants, in parallel, they measured human olfactory masking with 6-rate scoring tests and obtained a correlation coefficient of 0.8 with the channel block. Thus olfactory masking in the sensory cilia is induced by the inhibition of cAMP-gated Ca²⁺ channels by odorants. Tripral, geraniol, linalool dihydromyrcenol and benzaldehyde among 16 chemicals showed strong adaptation in terms of both cAMP-gated Ca²⁺ channels and human olfactory masking tests. Since these compounds differ significantly in structure, adaptation of the olfactory system seems to occur for many types of odorants. These findings may facilitate the design of masking chemicals, targeting olfactory manipulation at the ciliary membrane. Geraniol, linalool or myrcenol in beverages such as tea and beer may induce masking of unpleasant odors such as amines or mercaptans produced in foods such as meat and fish.

Other mechanisms for olfactory masking are also proposed. Takahashi et al. (2004) mapped alkylamine-responsive glomeruli to a subregion of the aliphatic acid-responsive and aldehyde-responsive cluster in odor maps of the rat olfactory bulb and found that fennel

and clove, species known to add flavor and mask fatty, fish odors, activated glomeruli in the surrounding clusters and suppressed the alkylamine-induced and acid-aldehyde-induced responses of mitral cells, suggesting that the masking is mediated, in part, by lateral inhibitory connections in the maps.

4. Effects through the olfactory system

4.1 Positron emission tomography

Odors are believed to be identified based on patterns of glomerular activity from information encoded in the olfactory bulb. Shepherd's group studied the spatial patterns of activity elicited in the rat olfactory bulb by odors such as amyl acetate, camphor, cage air, dimethyl disulfide, and pure air, using the 2-deoxyglucose autoradiography technique (positron emission tomography: PET), and found them to be different but overlapping (Stewart et al., 1979). The regions of activity were greatest in extent and density with the highest odor concentrations. These results define the regions within which more restricted and isolated foci appear at lower concentrations. The results provide evidence for the specific role of spatial factors in the neural processing of the quality and concentration of an odor. Further, Johnson et al. (2005) studied whether interactions between fragrant functional groups and the hydrocarbon structure influence activity in glomerular response modules, and the effects of the positions of functional groups on spatial representations of aliphatic odorants and the chemotopic representations of aromatic odorants in the rat olfactory bulb. They concluded that different odors are represented by different patterns of spatial activity in the olfactory bulb.

4.2 Electroencephalography

The effects of fragrances on human mood have been studied by electroencephalography (EEG). It is known that α waves increase empirically when people close their eyes and are relaxed. Field et. al. (2005) measured EEG patterns and heart rate for 11 healthy adults who sniffed a cosmetic cleansing gel with a lavender fragrance. The lavender smell had a significant transient effect of improving mood, allowing the subjects to feel more relaxed and perform math computations faster. A specific cosmetic fragrance can have a significant role in enhancing relaxation. Reportedly, fragrances of wine, whiskey, beer and coffee also increased α waves of human subjects, suggesting relaxation (Yokogoshi, 2006). Sniffing of six red or white wines increased α waves from 12 to 13 Hz compared to a 12% ethanol aqueous solution. The increase in α wave caused by the wines had a close correlation with mental state. With the increase of wine aroma concentrations, different kinds of wines showed some difference in their effect on α waves. Spectral information on the frequency fluctuation of α waves calculated for each individual is related to psychologically evaluated values of positive-negative moods and feelings of arousal to identify correspondence between the values of fluctuation characteristics and psychological conditions. A mixture of ethyl acetate and isoamyl acetate significantly exhibited a relaxing (lowering arousal) effect on humans, suggesting that ester flavors contribute to the increase in relaxed feeling one experiences while drinking beer (Yokogoshi, 2006).

Event-related potential has been studied by electroencephalography as fragrances of whiskey or coffee are administered by inhalation. These fragrances increased the amplitude

of the late component at 300 msec (P300) of evoked potential change and decreased the latency, suggesting that they induced mental relaxation and improved the ability to manage information (Chuyen & Ishikawa, 2008; Yokogoshi, 2006).

4.3 Green grass odor

The equivalent mixture of (*Z*)-3-hexenol and (*E*)-2-hexenal (leaf alcohol and leaf aldehyde), “green odor”, is present in teas and known to have a healing effect on the psychological damage caused by stress. Behavioral studies in humans and monkeys have revealed that green odor prevents the prolongation of reaction time caused by fatigue. Nakashima et al. (2004) investigated the effect of the green odor on elevations in plasma adrenocorticotrophic hormone (ACTH) levels induced by restriction stress in male rats. Rats that inhaled the odor while under stress showed a significant reduction in plasma ACTH levels in comparison with the vehicle-treated group. Sasabe et al. investigated the regions of the brain activated by green odor using positron emission tomography (PET) with alert monkeys and found that not only the prepyriform area (the primary olfactory cortex) and the orbitofrontal cortex (the secondary olfactory cortex), but also the anterior cingulate gyrus were activated (Sasabe et al., 2003).

4.4 Effect of fragrances on the autonomic nervous system

Nagai's group measured the effect of olfactory stimulation with scents of essential oils and their main components on the autonomic nerves, lipolysis and appetite in urethane-anesthetized rats. They measured the effect on both renal sympathetic nervous activity (RSNA) and gastric vagal (parasympathetic) nervous activity (GVNA). They observed that olfactory stimulation with the scent of grapefruit oil and its major component, limonene, for ten minutes enhanced RSNA and suppressed GVNA, increased the plasma glycerol concentration, blood pressure and body temperature, and decreased appetite (Shen et al., 2005a), while stimulation with the scent of lavender oil and its major component, linalool, had the opposite effects on the autonomic nerves, the plasma glycerol concentration and appetite (Shen et al., 2005b). The effects of essential oils and their components on the autonomic nerves were induced through the olfactory system, since local anesthesia of the nasal mucosa with xylocaine or anosmic treatment using ZnSO₄ eliminated the autonomic changes. Intracerebral administration of diphenhydramine, a histaminergic H₁-antagonist, abolished the effect of olfactory stimulation with the grapefruit essential oil and limonene on RSNA, GVNA and blood pressure. Bilateral lesions of the hypothalamic suprachiasmatic nucleus (SCN) eliminated the aroma-mediated increases in RSNA and blood pressure and decrease in GVNA. These results suggest that the smell of grapefruit essential oil affects autonomic neurotransmission and blood pressure through central histaminergic nerves and the SCN (Tanida et al., 2005). The effects of essential oils of grapefruit and lavender, and their components, are summarized in Table 3. In further studies, essential oils of rosemary, lemon, fennel, estragon, ylang ylang, peppermint, geranium (Egypt), lemon grass and coriander, and cineol enhanced RSNA and suppressed GVNA as grapefruit oil did, while essential oil of chamomile suppressed RSNA and enhanced GVNA as lavender oil did (Nijima, 2008). Though aromatic compounds are usually thought to have tranquillizing effects, these results suggested that most essential oils acted on the sympathetic nervous activity in the autonomic nervous system. Herbal teas such as chamomile or lavender are

expected to exhibit tranquillizing activity, while herbal teas containing citrus peel, peppermint, lemon grass or coriander induce mental arousal.

Aroma	Sym. NS	Parasym. NS	BP	PGC	Temperature	Weight
Grapefruit essential oil (rich in limonene)	↑	↓	↑	↑	↑	↓
Lavender essential oil (rich in linalool)	↓	↑	↓	↓	↓	↑

Sym. NS: Sympathetic nervous system, Parasym. NS: Parasympathetic nervous system, BP: Blood pressure, PGC: Plasma glycerol concentration
↑: Increase, ↓: Decrease

Table 3. Effect of grapefruit and lavender essential oil on the autonomic nervous system in rats (Shen et al., 2005a,b).

The effect of fragrance of Scotch-type whiskey (Hibiki produced by Suntory Ltd., in Japan, and stored in an oak barrel for 17 years) on the autonomic nervous system was examined by a similar method (Nijima et al., 2009). Olfactory stimulation with fragrance of whiskey increased GVNA and inhibited RSNA. These observations suggest that fragrance of whiskey may activate gastric movement and secretion of gastric juice through the vagus nerve, and decrease energy expenditure through suppression of the sympathetic nerve activity. The effect of the administration of whiskey fragrance for ten minutes on the autonomic nerve system continued for 2 hours after the administration.

Fushiki's group studied the effect of inhaling the aroma of jasmine tea and lavender on the autonomic nervous system by conducting a power spectral analysis of heart rate variability in human subjects (Inoue et al., 2003; Kuroda et al., 2005). It is thought that parasympathetic nervous activity increases in relation to spectral integrated values for high-frequency components. The jasmine tea and lavender caused significant decreases in heart rate and significant increases in spectral integrated values for high-frequency components in comparison with the control, suggesting the activation of the parasympathetic nervous system which induces sedative effects. Dayawansa et. al. (2003) measured the effect of cedrol, the main component of the essential oil of cedar wood, on the autonomic function of healthy individuals. A spectral analysis of heart rate indicated an increase in high-frequency components (index of parasympathetic activity), and a decrease in the ratio of low-frequency to high-frequency components (index of sympathovagal balance) during inhalation, which is consistent with the idea of a relaxant effect of cedrol.

5. Effects of fragrances through incorporation into the body

It has been studied extensively how active components such as ethanol and caffeine act on neurotransmitter receptors and affect the mental state, inducing addiction. Ethanol potentiates the response of GABA_A receptors composed of $\alpha_4\beta_3\delta$ and $\alpha_6\beta_3\delta$ subunits in outer synaptic regions under physiological conditions (Martin & Olsen, 2000), though it may also inhibit NMDA receptors and voltage-dependent channels. Caffeine inhibits adenosinA2a receptors noncompetitively under physiological conditions (Yoshimura, 2006), though it may also inhibit both GABA_A receptors and phosphodiesterase. These activities are modulated further by the fragrant compounds in beverages.

5.1 Incorporation of fragrances into the body

Effects of aromatic compounds not only through stimulation of the olfactory system, but also through incorporation into the body are described in most technical books on aromatherapy. Incorporation into the body through the skin has been reported by some researchers. The rate at which compounds move through cell membranes generally increases with their hydrophobicity and a decrease in their molecular weight. Since one can feel the effects of ethanol on consciousness soon after drinking liquor, the idea that fragrances of higher alcohols are also incorporated into the brain makes sense. Reportedly, levels of fragrances such as linalool and its acetyl ester in blood reach a plateau 15-20 min after their administration to human skin by massage and decrease gradually for 2 h. Cal (2006) studied the percutaneous absorption of terpenes such as linalool, terpinen-4-ol, citronellol and α -pinene. Components of essential oils accumulated in the mouse brain following percutaneous absorption or exposure to vapor, since they are usually hydrophobic. Ylang ylang (*Cananga odorata*) oil caused a significant decrease in blood pressure and a significant increase in skin temperature when administered transdermally (Hongratanaworakit et al., 2006). At a behavioral level, subjects given ylang ylang oil dissolved in pure sweet almond oil rated themselves as calmer and more relaxed than subjects in the control group given only pure sweet almond oil. Linalool was applied percutaneously to 14 healthy subjects and induced deactivation with respect to physiology, that is, a decrease of systolic blood pressure and a smaller decrease of skin temperature, compared to the corresponding control group. However, the target of aromatic compounds after their incorporation into the body has not been clarified.

5.2 GABA_A receptors and their potentiation

We have found that many fragrant compounds potentiated the electrical response of GABA_A receptors expressed in *Xenopus* oocytes by injection of poly(A)⁺RNA or cRNA of the receptors (Fig. 5, Fig. 6 a and b) (Aoshima & Tenpaku, 1997; Hossain & Aoshima, 2008). GABA_A receptors are ligand-gated ion channels whose subunits have similar amino acid sequences to those of ionotropic nicotinic acetylcholine, serotonin (type 3), and glycine receptors (Chebib & Johnston, 2000; Johnston et al., 2006; Nicholls, 1994). They are thought to have heteropentamers made up of subunits likely derived from a common ancestor. The cDNAs of about 20 mammalian GABA_A receptor proteins have been cloned, including α , β , γ , δ , ϵ , π , and ρ subunit cDNAs, together with a few splice variants. There may be 50-100 combinations expressed in the brain. The different combinations may result in different pharmacological characteristics, for example, affinity for GABA. GABA_A receptors are mood-defining receptors and have a complex pharmacology, with binding sites for direct GABA agonists and antagonists, together with multiple allosteric sites for benzodiazepine tranquilizers, barbiturate central nervous system depressants, both synthetic and endogenous steroids, general anesthetics, and ethanol. Since many aromatic compounds are higher alcohols, it is not unusual that they also potentiate the response of GABA_A receptors.

The effects of the functional groups of various six-carbon hydrocarbons on the response of GABA_A receptors were studied by expressing the receptors in *Xenopus* oocytes (Aoshima et al., 2001). 1-Hexanol best potentiated the response. Hexanal, butyl acetate and hexylamine potentiated the response slightly, while hexanoic acid inhibited the response weakly in a competitive manner. The potentiating effect of alcohols increased along with chain length.

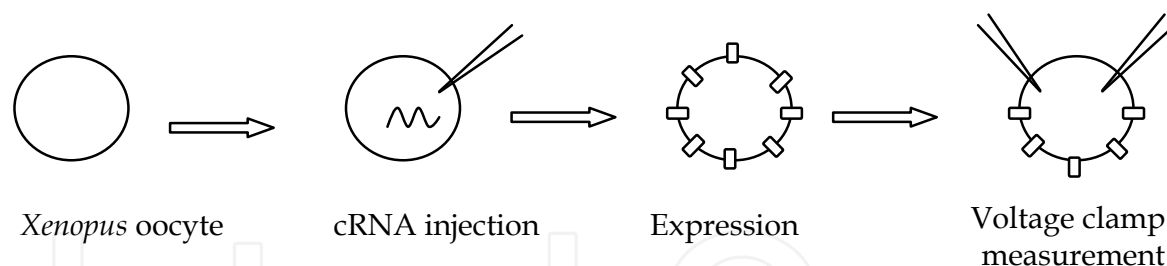

Fig. 5. The experimental procedures using the *Xenopus* oocyte expression system and electrophysiological measurements to examine the effects of fragrant compounds on the response of GABA_A receptors.

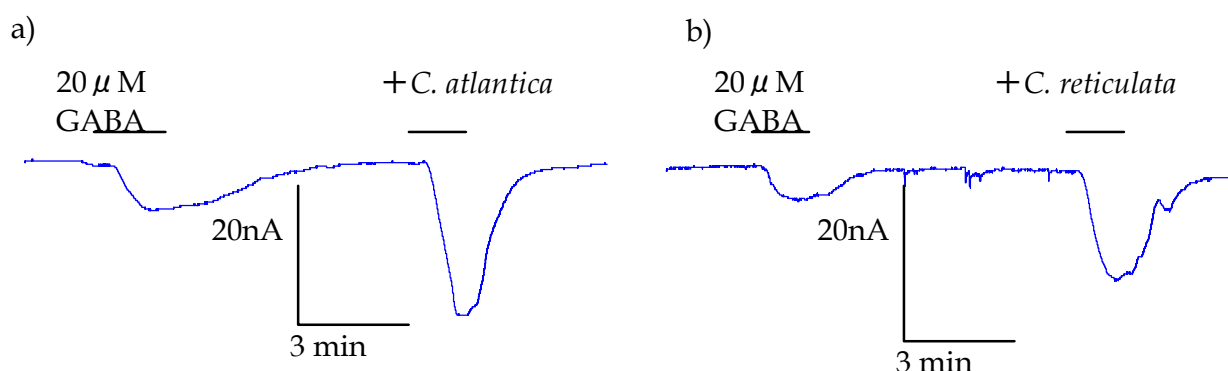

Fig. 6. Potentiation of the response of GABA_A receptors expressed in *Xenopus* oocytes when essential oil of a) *C. Atlantica* (*Atlas cedar*) or b) *C. Reticulate* (*Mandarin orange*) was co-applied with GABA (Aoshima et al., 2009), taken with permission from Fragrance Journal Ltd, Japan.

The potentiation of the response depended on the GABA concentration, that is, less than 20 μM potentiated the response, while more than 100 μM did not. The addition of aromatic compounds to GABA solutions shifted the dose-response curve of GABA to the lower concentrations, similar to anesthetics (Franks & Lieb, 1994).

Since ionotropic neurotransmitter receptors are thought to have evolved from a common ancestor, they have not only a similar structure but also a common functional mechanism. A minimum schematic model for nicotinic acetylcholine receptors (Hess et al., 1983) has been developed to explain the potentiation of the response of the GABA_A receptors as shown in Fig. 7. The binding of two agonist molecules to the receptor (RL_2) with a dissociation constant of K_1 is necessary to open the channel. The receptors with two bound agonists are converted to an open channel ($RL_2(\text{open})$), reaching equilibrium. The receptors occupied by the agonist(s) change their structure to a desensitized form (D) and close the channel, at a rate less than that of channel opening. The potentiator (P), *i.e.* aromatic compound, binds to the receptor with a dissociation constant of K_p . The receptor occupied by the potentiator (RP) binds the GABA molecule with a dissociation constant of K_{1p} . Since K_{1p} is less than K_1 , the open form of the receptor with the potentiator increases and the response is potentiated in the presence of the potentiator, when the GABA concentration is low (Aoshima et al., 2001).

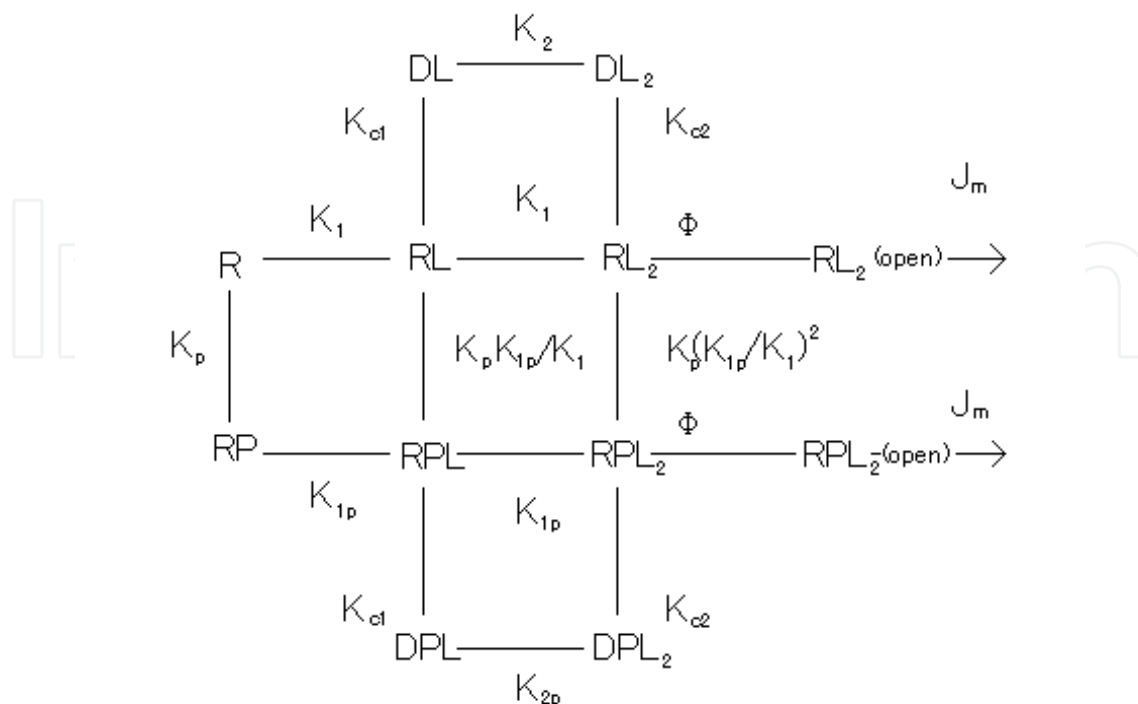

Fig. 7. The simplest schematic model accounting for the potentiation of the GABA_A receptor-response (Aoshima et al., 2001), taken with permission from the Japanese Biochemical Society. The affinity for GABA of the GABA_A receptors increases ($K_{1p} < K_1$) when aromatic compounds bind the receptor with a dissociation constant of K_p , increasing the open-form of the receptor and potentiating the response.

5.3 Target of ethanol against GABA_A receptors

It is reasonable to think that higher alcohols bind to the same site as ethanol. The potentiation site of ethanol is expected to be composed of α and β subunits, though the γ subunit is essential for potentiation of the response of the GABA_A receptors by benzodiazepine. By using chimeric receptor constructs, Mihic et al. (1997) identified a region of 45 amino-acid residues that is both necessary and sufficient for the enhancement of receptor function. Within this region, two specific amino-acid residues in trans-membrane domains 2 and 3 (TM2 and TM3) are critical for allosteric modulation of GABA_A receptors by alcohols and volatile anesthetics. The potentiation site of the receptors appears to have both hydrophobic and hydrophilic group-binding regions. The hydrophilic group-binding region, which recognizes the functional group, binds best to a hydroxyl group. Not only alcohols, but also phenol derivatives potentiated the response of the GABA_A receptors strongly, though polyphenols inhibited the response (Aoshima et al., 2001). The hydrophobic group-binding region is large enough to bind a hydrocarbon of at least 10 carbon atoms (Aoshima et al., 2001).

Wallner et al. (2003) reported that ethanol at low concentrations enhanced the response of $\alpha_4\beta_3\delta$ and $\alpha_6\beta_3\delta$ GABA_A receptors expressed in *Xenopus* oocytes. These receptors are usually present in extrasynaptic regions of neurons. Thus higher alcohols possibly bind to the same

site and receptors as ethanol, and enhance the response of the GABA_A receptors. However, effects of fragrant substances on the responses of GABA_A receptors composed of various combinations of subtypes have not been examined yet.

5.4 Potentiation of the response of GABA_A receptors by liquors

The potentiation of the GABA_A receptors by various compounds is summarized in Table 4 (Aoshima et al., 2008). Flavors in beverages are very important and determine their quality. Effects of flavors in tea, coffee, whiskey and beer on GABA_A receptor's responses have been studied using an *Xenopus* oocyte expression system and electrophysiological measurements (Hossain et al., 2007). Many components of the flavors in the beverages potentiated the response of the receptors. Since most of the aromatic compounds in essential oils and beverages are lipophilic, they are incorporated into the blood stream, cross the blood-brain barrier, and act on GABA_A receptors in the brain, which may modulate mental state, mood, or consciousness.

Compound: formula	K _p (mM)	V _m (%)	K _{1p} (μM)
Cineol: C ₁₀ H ₁₈ O	0.11	255	34
Citral: C ₁₀ H ₁₆ O	0.21	181	41
Eugenol: C ₁₀ H ₁₂ O ₂	0.18	284	32
Terpinen-4-ol: C ₁₀ H ₁₈ O	0.15	635	16
Linalool: C ₁₀ H ₁₈ O	0.32	332	31
Geraniol: C ₁₀ H ₁₈ O	0.78	258	34
1-Octen-3-ol: C ₁₀ H ₁₆ O	0.76	688	21
Myrcenol: C ₁₀ H ₁₆ O	0.35	353	31

K_p and V_m are the dissociation constant of the complex followed by the receptor and potentiator, and the maximum potentiation of the receptors in Figure 7 when all the potentiation sites were occupied by the potentiator (Aoshima et al., 2001, 2008). The chemical structures of the compounds are shown in Fig. 1.

Table 4. Estimated constants, K_p, V_m and K_{1p}, of several fragrant compounds.

Most flavors specific to matured whiskey potentiated the response of the receptors. Though fragrant components are much less numerous than ethanol in whiskey, the dose-potentiation relationship showed that they potentiated the response of GABA_A receptors a thousand times more than ethanol (Fig. 8) (Hossain et al., 2002a). The potentiation of the GABA_A receptor's response by whiskey can be measured by adding whiskey itself to the GABA solution, since whiskey is a distilled liquor and contained no GABA but various compounds are moved into whiskey from an oak barrel during aging. The whiskey, produced by Suntory Ltd. in Japan, also potentiated the response of GABA_A receptors more than did ethanol. The potentiation increased with the aging period of the whiskey in oak barrels (Fig. 9), with a very high correlation between the two (Koda et al., 2003). Various types of whiskies produced in different countries also potentiated the response, though the degree of the potentiation showed some variation. An aged whiskey with much fragrance may induce intoxication with less toxicity of ethanol than a less-aged whiskey, since whiskey amount consumed can be reduced.

Beer, brewed liquor, caused high GABA-like activity. An extract of beer was prepared using pentane (EXT) to examine the presence of modulators of GABA_A receptors in beer. Though

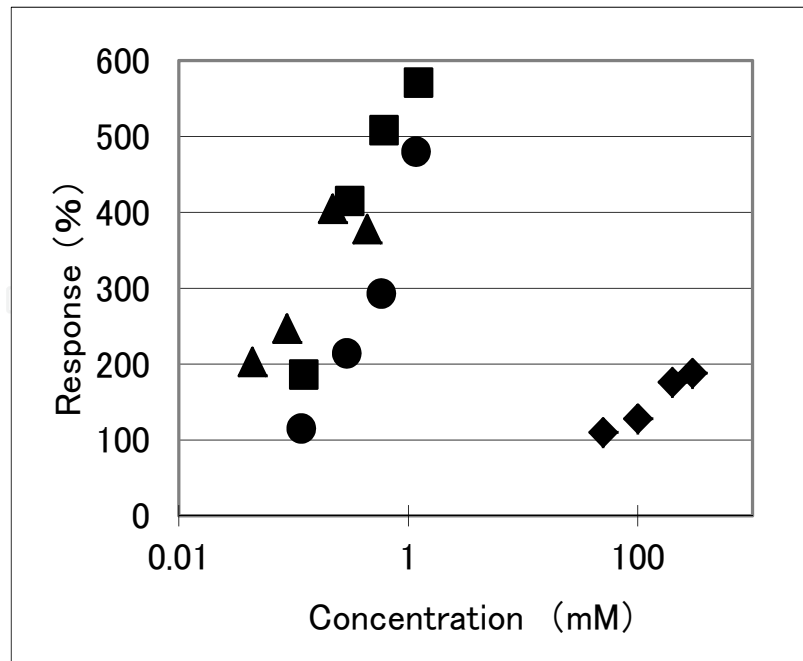

◆:ethanol, ●:quercus lactone, ▲:1,1-diethoxyheptane, ■:ethyl phenylpropanoate.

Fig. 8. Dose-potential relationship of some fragrances in whiskey and ethanol on the response of $GABA_A$ receptors expressed in *Xenopus* oocyte as shown in Fig. 5, $n = 4$ (Hossain et al., 2002a), taken with permission from the American Chemical Society. The response caused by $0.25 \mu M$ GABA was taken as a control (100%).

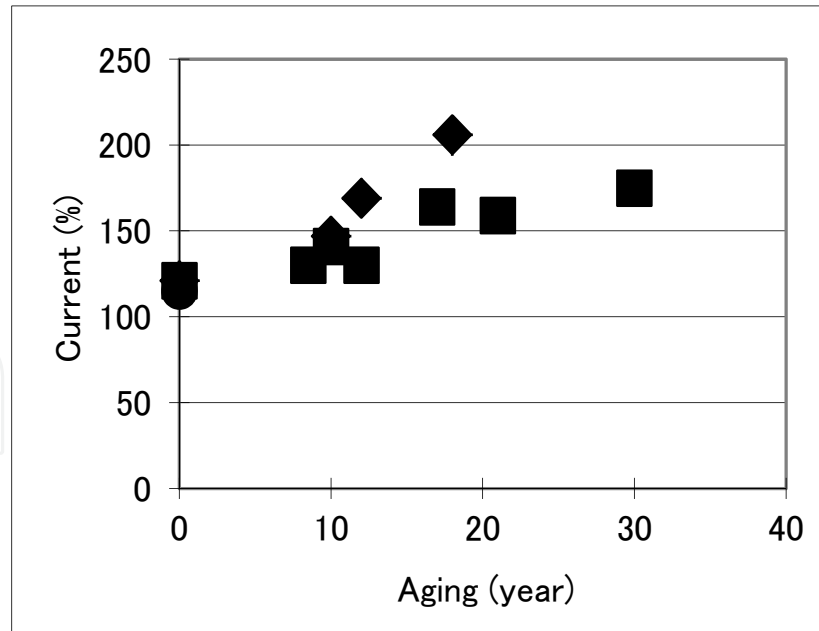

◆ : single malt whiskey, ■ : blended malt whiskey.

Fig. 9. Effect of aging period of whiskey on the response of the $GABA_A$ receptors caused by $0.25 \mu M$ GABA as shown in Fig. 5, $n = 4$ (Koda et al., 2003), taken with permission from the American Chemical Society. The response caused by $0.25 \mu M$ GABA was taken as a control (100%).

beer itself contains GABA-like activity, EXT induces no electrical response in the GABA_A receptor-expressing oocytes, indicating the absence of GABA-like activity in EXT. However, addition of this extract causes the potentiation of the GABA_A receptor-response elicited by 0.25 μ M GABA dose-dependently (Aoshima et al., 2006).

Beer is mostly produced from malted barley, water and hops, and is reported to contain fragrant compounds such as alcohols, esters, aldehydes, and hydrocarbons (Maarse, 1991). The fragrances in beer possibly come from two sources, fermentation and the addition of hops. Brewers' yeast produces not only ethanol, but also fusel alcohols such as various butanol and pentanol derivatives (Maarse, 1991), which potentiate the response of GABA_A receptors (Aoshima et al., 2001). These alcohols are oxidized to form aldehydes and carboxylic acids. Then various esters are synthesized between alcohols and carboxylic acids. Aliphatic esters potentiated the GABA_A receptor-response (Aoshima et al., 2006).

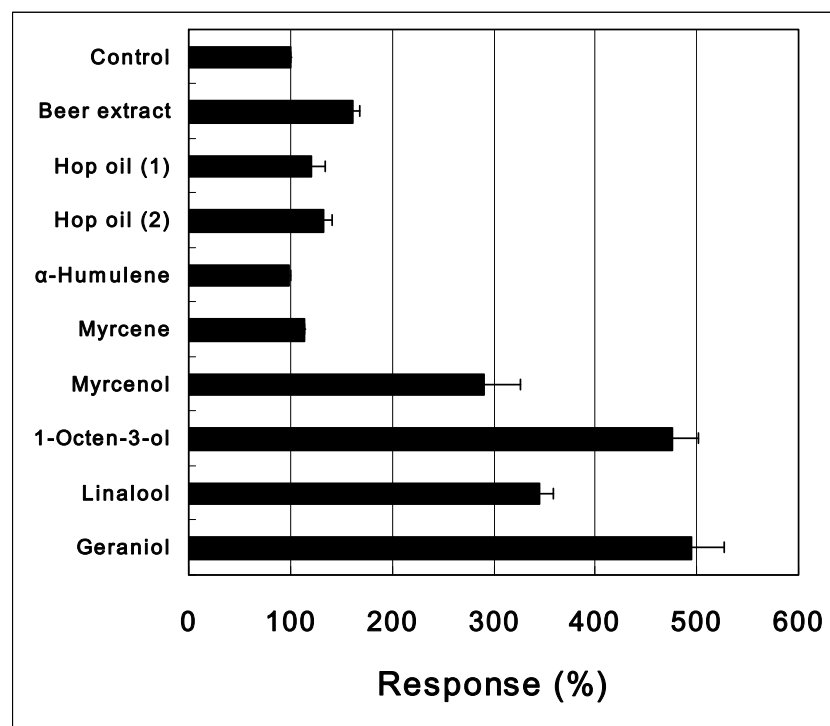

Fig. 10. Potentiation of the response of the GABA_A receptors by fragrances in beer as shown in Fig. 5, $n = 4$ (Aoshima et al., 2006), taken with permission from the American Chemical Society. The response caused by 0.25 μ M GABA was taken as a control (100%). Error bars represent the standard deviations.

The esters tended to potentiate the response less as their carbon chain length increased, though this may be attributed to the solubility of the esters. Propyl acetate and ethyl propanoate showed similar dose-dependency in the potentiation of the GABA_A receptor's response.

Sweet wort is boiled with hops to give its characteristic bitter taste. Hops includes various fragrances such as α -humulene, myrcene, linalool, geraniol and 1-octen-3-ol. α -Humulene and myrcene are typical hydrocarbons present in hops (Maarse, 1991) and humulenol and myrcenol are produced from α -humulene and myrcene during the boiling of wort with hops. α -Humulene and myrcene have little effect on the GABA_A receptor, but the alcohol

myrcenol potentiates the response strongly. Linalool, geraniol, and 1-octen-3-ol also potentiate the receptor's response strongly (Fig. 10). However these compounds do not induce the response of GABA_A receptors, that is, they do not act as an agonist. Reportedly, a hops' (*Humulus lupulus L.*) CO₂ extract exhibited pentobarbital sleep-enhancing properties and antidepressant activity in rats (Zanoli et al., 2005). However, Schellenberg et al. (2004) reported that the fixed combination of valerian and hops acts via a central adenosine mechanism which is possibly the reason for its sleep-inducing and -maintaining activity. So further studies are necessary to clarify how hops affect our mood.

5.5 Effects of components in tea and coffee on the response of GABA_A receptors

The effects of several components of brewed teas on the response of GABA_A receptors were measured as shown in Fig. 11 (Hossain et al., 2002b, 2004). Most fragrant components potentiated the response, while methyl xanthines such as caffeine and polyphenols such as catechin inhibited it. An extract of green tea made with diethyl ether, which contains lipophilic components such as caffeine and catechin in green tea thought to be incorporated into the brain, inhibited the response elicited by GABA, possibly because the amounts of caffeine and catechin derivatives were much larger than those of fragrant components. The responses of GABA_A receptors were measured as summarized in Fig. 5, and the control was the response by 1 μ M GABA without the other components in teas.

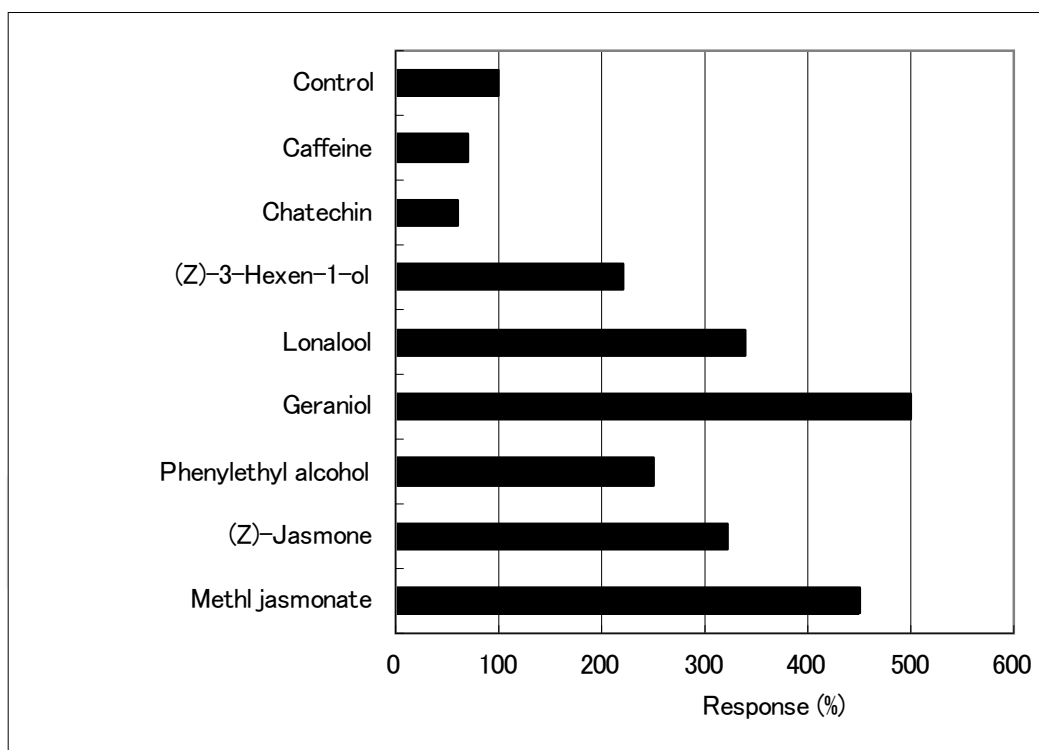

Fig. 11. Effects of compounds in teas on GABA-induced response of the GABA_A receptors as shown in Fig. 5, n = 4 (Hossain et al., 2002b, 2004) The response caused by 1 μ M GABA was taken as a control (100%), taken with permission from the American Chemical Society.

Effects of many components of coffee on the response of GABA_A receptors were measured as shown in Fig. 12 (Hossain et al., 2003). Most fragrant components potentiated the

response, but methyl xanthines and chlorogenic acid inhibited it. The extract of coffee obtained with diethyl ether slightly potentiated the response at low concentrations, but inhibited it at high concentrations. This result suggests that the extract contains two types of components: fragrant components that potentiated the response with high affinity for the receptors and components such as caffeine and chlorogenic acid that inhibited the response with low affinity for the receptors.

Herbal teas contain various fragrant compounds with pleasant smells (Nagashima, 2010). It is believed that they have beneficial effects such as tranquillizing, anti-stress, anti-bacterial, anti-oxidative, anti-inflammatory and anti-fatigue activities, though some of these properties may come from polyphenols or pigments. Reportedly, some herbal teas increase appetite, the digestion of food, blood flow in vessels and urination, while others stimulate arousal.

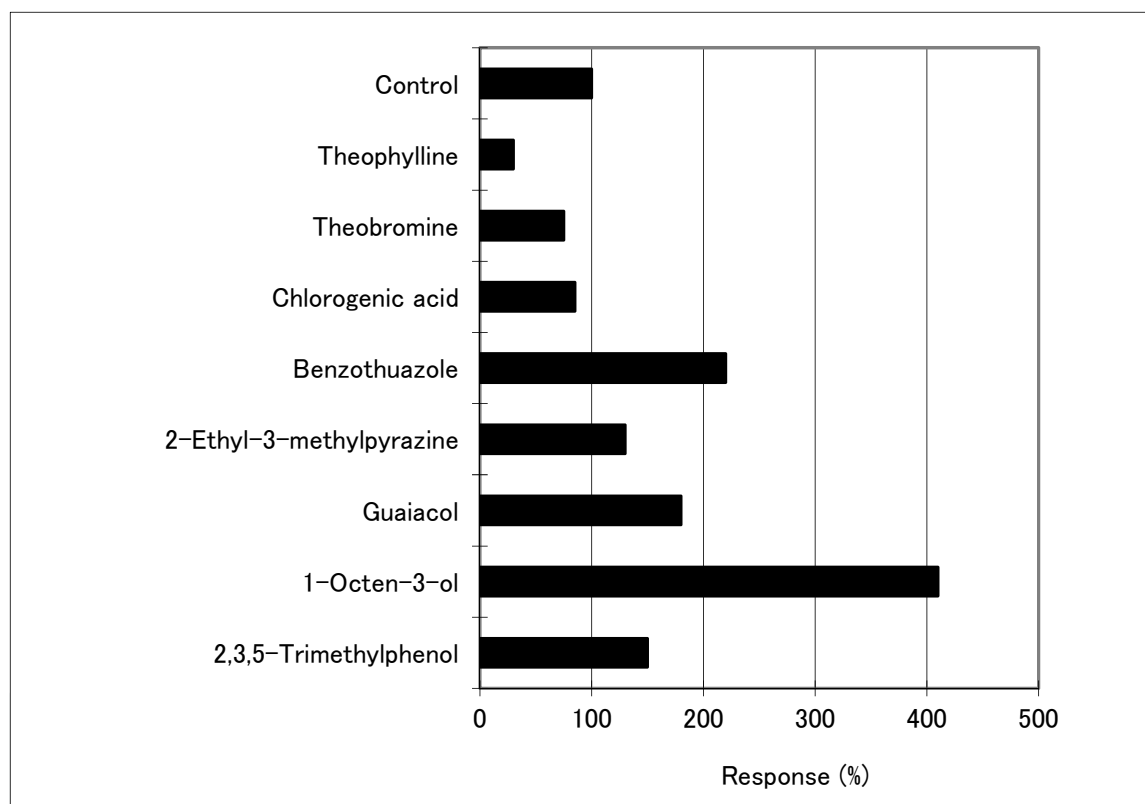

Fig. 12. Effects of compounds in coffee on GABA-induced response of the $GABA_A$ receptors as shown in Fig. 5, $n = 4$ (Hossain et al., 2003) The response caused by $0.25 \mu M$ GABA was taken as a control (100%), taken with permission from the American Chemical Society.

6. Pharmacological and animal behavioral studies

6.1 Extension of sleeping time and the block of convulsion in mice by fragrances

Pentobarbital potentiates the response of $GABA_A$ receptors and induces sleep in higher animals. The co-administration of aromas which potentiate the response of $GABA_A$ receptors in *Xenopus* oocytes, with pentobarbital is expected to extend sleeping time, since the pentobarbital and aromas have an additive effect on the receptors. A close relationship

has been observed between the potentiation of the response of GABA_A receptors expressed in *Xenopus* oocytes and the extension of sleeping time by essential oils of various trees (Aoshima et al., 2009). Extensions of sleeping time in mice by fragrances were induced by various methods such as intraperitoneal, inhalational and oral administration (Aoshima et al., 2009; Mubassara et al., 2008). Inhalation of whiskey by mice increased the sleeping time induced by pentobarbital more than did inhalation of ethanol (Fig. 13) (Koda et al., 2003).

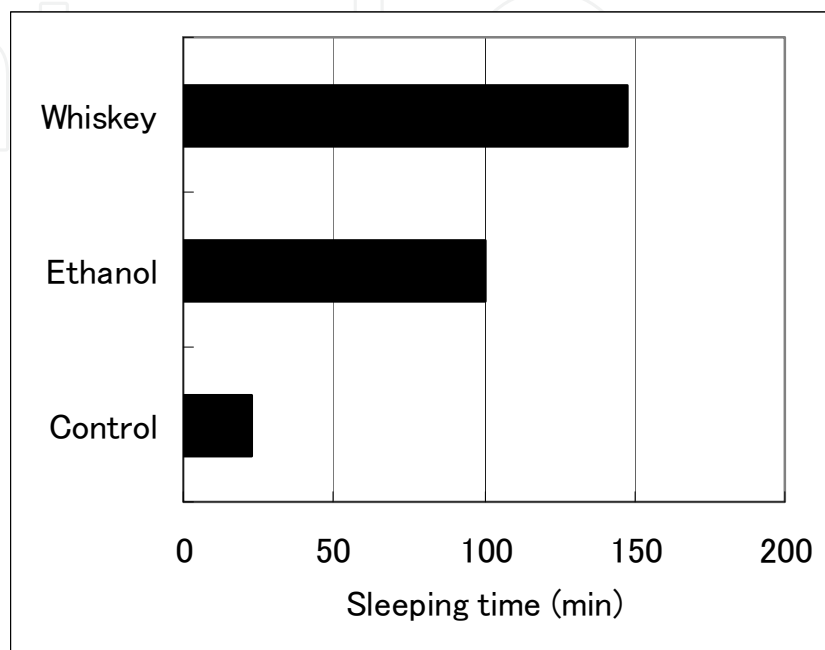

Fig. 13. Effect of ethanol (43%) and whiskey (Scotch-type whiskey made by Suntory Ltd. with 43% ethanol) on sleeping time induced by pentobarbital (sleeping drug) in mice, $n = 5$ (Koda et al., 2003), taken with permission from the American Chemical Society. Control means that only sodium pentobarbital (50 mg/kg) was injected intraperitoneally into rats.

Aromatic components of beverages, *cis*-jasmone and methyl jasmonate in oolong tea, 1-octen-3-ol in coffee, and myrcenol in beer, potentiated the response of the GABA_A receptors and extended sleeping time when they were co-administered with pentobarbital (Hossain et al., 2007). Therefore, aromatic compounds in beverages are possibly taken up by the brain, and thereby potentiate the response of the GABA_A receptors additively, and extend sleeping time, though the possibility that aromatic compounds inhibit the decomposition of pentobarbital in the liver cannot be excluded. Inhalation or intraperitoneal administration of compounds such as terpinen-4-ol, which potentiate the response of GABA_A receptors even without pentobarbital, could induce abnormal behavior similar to that caused by the administration of liquors or anesthetics (Aoshima et al., 2009).

Tsuchiya et al. (1992) reported that pentobarbital-induced sleeping time in mice was prolonged by terpinyl acetate and phenethyl alcohol, and shortened by lemon oil and jasmine oil, and that no effect of the aromatic compounds was observed on pentobarbital-induced sleep when using anosmic mice produced by intranasal zinc sulphate treatment, suggesting that the effect of odors on sleeping time is induced through the olfactory system. Thus, aromatic compounds at low concentrations may also affect sleep caused by pentobarbital through the olfactory system possibly via the autonomic nervous system.

Pentetrazole, an antagonist of GABA_A receptors, induces convulsions through inhibition of GABA_A receptor-elicited responses in the brain. Yamada et al. (1994) found that inhaling lavender oil vapor blocked pentetrazole-induced convulsions in mice, suggesting a potentiation of the GABA_A receptor's response by lavender oil. The intraperitoneal administration of ethyl phenylpropanoate, which is one of the fragrances in whiskey and potentiates the response of GABA_A receptors, delayed significantly convulsions caused by pentetrazole in mice, suggesting that ethyl phenylpropanoate potentiates the response of GABA_A receptors against inhibition of the response by pentetrazole (Hossain et al., 2002a).

6.2 Anti-stress and anti-conflict effects of fragrances

Mental or physical stress induces the release of stress hormones such as corticotrophin-releasing hormone (CRH) and adrenocorticotrophic hormone (ACTH) from the paraventricular nucleus or pituitary gland. Yamada et al. (1996) found that the intraperitoneal administration of diazepam, a benzodiazepine, suppressed plasma ACTH levels in ovariectomized rats under restriction-stress. Similar effects on the plasma ACTH level were observed in ovariectomized rats when chamomile, lemon and lavender oil, or their components were administered by inhalation. Inhalation of terpinen-4-ol and 1-octen-3-ol suppressed ACTH levels significantly (Fig. 14) (Aoshima et al., 2009). Inhalation of linalool, cineol, α -terpineol and mastic tree oil also suppressed ACTH levels, but not significantly. The plasma ACTH levels of ovariectomized rats under restriction stress were greater than those of normal rats, since the ovariectomized rats, used as an experimental menopausal model, are likely to be affected by the stress. Inhalation of whiskey fragrances by rats decreased restriction-stress-induced increases in the plasma adrenocorticotrophic hormone (ACTH) level, suggesting an anti-stress effect (Yokogoshi, 2006).

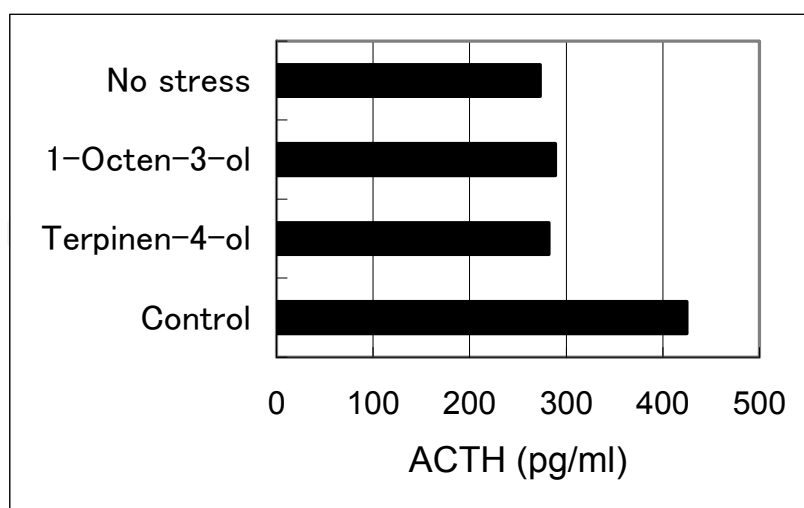

Fig. 14. Suppression of plasma ACTH levels in rats by inhaled aromas under restriction stress, $n = 10$ (Aoshima et al., 2009), taken with permission from Fragrance Journal Ltd., Japan. Rats were kept under restriction stress for 1 hour with inhalation of 1-octen-3-ol or terpinen-4-ol. Control rats were kept for 1 hour under restriction stress without inhalation of aromas. Plasma ACTH concentrations were measured by the immunoradiometric assay.

Anticonflict effects of rose oil and its components such as 2-phenethyl alcohol and citronellol were observed in Geller and Vogel conflict tests in mice administered intraperitoneally (Umezu, 1999, 2000). In mice, the intraperitoneal injection of fragrant compounds such as terpinen-4-ol significantly increased both the number of entries in open arms and time spent in the open arms in the elevated plus maze (Fig. 15), indicating anti-anxiety effects as did muscimol and diazepam, an agonist and a potentiator of GABA_A receptors, respectively. Effects of lavender and rose oils on rodents were also measured in the elevated plus maze and their anxiolytic effects were observed (Tsang & Ho., 2010).

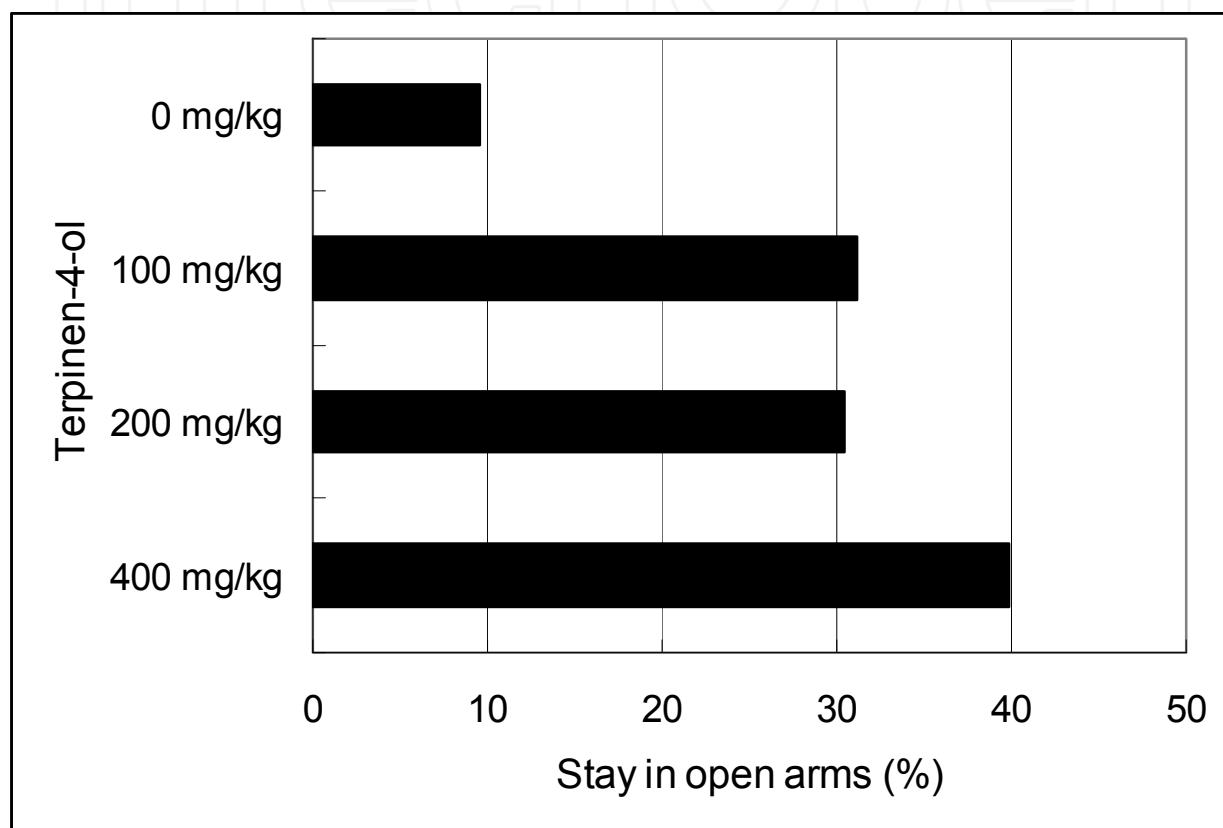

Fig. 15. Anti-anxiety-like effect of terpinen-4-ol in the elevated plus maze. The stay in the open arms of an elevated plus maze was measured for 15 min 30 min after the intraperitoneal administration of terpinen-4-ol dissolved in olive oil in mice. (n = 12). The control mice (0 mg/kg) were intraperitoneally injected with only olive oil. As a positive control, increase of stay in open arms in mice was confirmed by injection of diazepam.

6.3 Ambulatory activity in mice

Peppermint oil is believed to be effective at treating mental fatigue. Umezu et. al. (2001) administered peppermint oil intraperitoneally to mice and found that their ambulatory (locomotor and rearing) activities, which were measured using a tilting-type ambulometer consisting of 10 bucket-like Plexiglas activity cages 20 cm in diameter (SAM-10, O'hara Co., Tokyo), increased dramatically. Intravenous administration of 1,8-cineol, menthone, isomenthone, menthol, (*R*)-(+)-pulegone, menthyl acetate or caryophyllene, which are components of peppermint oil, also induced a significant increase in ambulatory activity at

much lower doses (20 mg/kg), Measurements of effects of a dopamine transporter-inhibitor, a tyrosine hydroxylase inhibitor, and antagonists of dopamine receptors on the ambulation of mice suggested that dopamine was involved in the ambulation-promoting effect of menthol (Umezu, 2009).

Fragrances in tea and coffee are expected to suppress the arousal effect of caffeine, since they potentiated the response of GABA_A receptors (Hossain & Aoshima, 2008). However, ethanol enhanced the ambulation-increasing effect of caffeine in mice, though diazepam and pentobarbital, which potentiate the response of GABA_A receptors specifically, reduce the effect of caffeine as expected (Kurihara, 1993). Terpinen-4-ol enhanced the ambulation-increasing effect of caffeine in mice similarly to ethanol (Fig. 16) (unpublished result). Since a antagonist of N-methyl-D-aspartate (NMDA) receptor, MK-801, also enhanced the ambulation-increasing effect of caffeine in mice (Kurihara et al., 1992), the enhancement is possibly caused by the inhibition of NMDA receptors in the brain of mice.

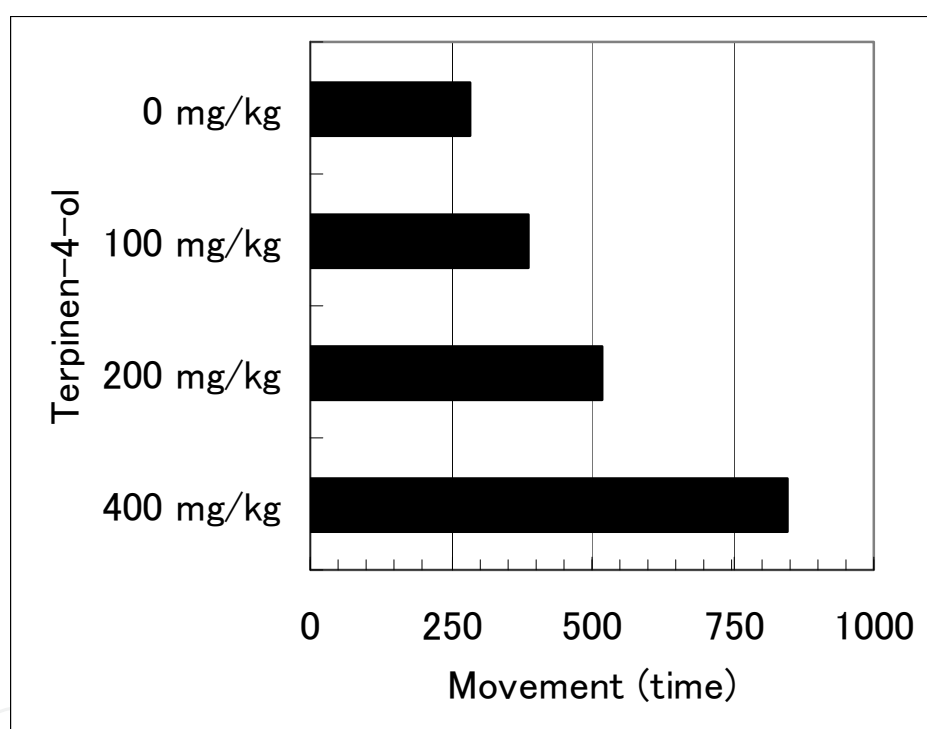

Fig. 16. Changes in ambulatory activity in mice after intraperitoneal administration of terpinen-4-ol and caffeine, measured by the tilting-type ambulometer for an hour, $n = 10$. Caffeine (10 mg/kg) was administered 30 min after administration of terpinen-4-ol dissolved in olive oil. As a control (0 mg/kg), caffeine was administered 30 min after administration of only olive oil.

7. Other activities

7.1 Anti-bacterial activity

Antibacterial activities of essential oils have been studied extensively. It is difficult to summarize these activities, since they vary in strength depending on the experimental conditions (Inoue, 2002). Terpenes derived from trees are named “phytoncids”, since most

of them have antibacterial activity. Until antibiotics were developed, essential oils have been used to disinfect medical equipment and to cure infective diseases, a practice known as medical aromatherapy. Some volatile compounds in herbs and spices have antibacterial activity and are used to preserve vegetables, fruits and foods (Yatagai, 2010).

One distinctive feature of essential oils or aromatic compounds is their very broad spectrum of activity, suppressing the growth of viruses, parasites, *mycoplasma*, bacteria and fungi, whereas antibiotics act on a certain range of species. Essential oils are more active against bacteria, which are aerobic, lipophilic and producing spores. Essential oils suppress growth generally in the following order: molds > Gram-positive bacteria and acid-fast bacillus > yeast > Gram-negative bacteria (Inoue, 2002).

It is widely thought that aromatic compounds act on the cell membrane. At low concentrations, they stabilize the membrane structure similar to anesthetics and suppress the flux of ions such as Na^+ and Ca^{2+} . At high concentrations, they disturb the membrane structure, increase the flux of ions through cell membranes and cause cell death. A vapor usually has higher antibacterial activity than a liquid at similar concentrations. Aromatic compounds can kill bacteria resistant to antibiotics such as Methicillin-resistant *Staphylococcus aureus* (Inoue, 2002).

Distilled liquors with high concentrations of ethanol were once used to sterilize wounds. However, the development of antibiotics has reduced this use. Fragrant compounds should increase the sterilizing activity of liquors. Teas, especially green tea, have anti-microbial and anti-viral activities, but it is likely that these effects come from catechin derivatives such as epigallocatechin 3-*O*-gallate (Uesato et al., 2003).

7.2 Immunological activity

The immunological system is associated with the endocrine and autonomic nervous systems. These three systems are controlled by the hypothalamus and maintain homeostasis. Aromas restored immunological activity which decreased under strong physical and mental stress, through stimulation of the olfactory system. Reportedly, a forest bathing trip increased human natural killer (NK) activity and expression of anti-cancer proteins in female subjects (Li et al., 2008). Exposure of phytoncides (wood essential oils) containing pinenes to humans significantly increased NK activity and the percentages of NK, perforin, granzyme, and granzyme A/B-expressing cells, and significantly decreased the percentage of T cells, and the concentration of adrenaline and noradrenaline in urine, suggesting that phytoncide exposure and decreased stress hormone levels partially contribute to increased NK activity (Li et al., 2006, 2009). In mice, a decrease in plaque-forming cells involving thymic involution induced by high-pressure stress (2.2 kg/cm²) caused by compressed air in a chamber was restored by long term inhalation of tuberose, lemon, oak-moss and labdanum for 24 h following the stress (Fujiwara et al., 1998). Inhalational treatment of rats with a citrus fragrance normalized neuroendocrine hormone levels and immune function and was rather more effective than antidepressants, imipramine (Komori et al., 1995).

Some essential oils suppress the release of histamine or leukotriene from mast cells or the production of cytokines. Lavender oil inhibited concentration-dependently cutaneous anaphylaxis induced by anti-dinitrophenyl (DNP) IgE in rats following both topical and

intradermal applications, the release of histamine from peritoneal mast cells by anti-DNP IgE, and the anti-DNP IgE-induced release of tumor necrosis factor-alpha (TNF α) from peritoneal mast cells, suggesting the suppression of immediate-type allergic reactions via the inhibition of mast cell degranulation in-vivo and in-vitro. The recruitment of leukocytes into the peritoneal cavity on the intraperitoneal injection of casein into mice was suppressed by intraperitoneal injections of geranium, lemongrass and spearmint oils at a dose of 5 μ L/mouse possibly because they suppress neutrophil recruitment (Aoshima et al., 2009; Wada & Yamazaki, 2004).

7.3 Action on TRP receptors

Menthol has specific targets, *i. e.* transient receptor potential vanilloid 3 (TRPV3) and transient receptor potential melastatin subfamily channel 8 (TRPM8) receptors. These receptors are non-selective cation channels with six trans-membrane domains and temperature-sensitive, that is, TRPM8 receptors open at below ca. 25 °C and TRPV3 receptors, at below ca. 32 °C. Thus, menthol acts as a cooling agent. Eucalyptol also opens the channels of TRPM8 receptors, and camphor and thymol open the channels of TRPV3 receptors (Palapoutian et al., 2003).

7.4 Inhibition of acetylcholinesterase

Acetylcholinesterase (AChE) inhibitors have been used in the treatment of Alzheimer's disease. Miyazawa et al. (1997, 2005) found that monoterpenoids with a *p*-menthane skeleton inhibited AChE. Essential oils of *Mentha* species such as *M. aquatica*, *M. gentiles*, and *M. avensis* also inhibited AChE (K_i = about 50 μ g/mL). The treatment of Alzheimer's disease is based on inhibition of the AChE, which hydrolyses acetylcholine, increasing acetylcholine available for transmission at the cholinergic synapse. Therefore, these essential oils and their components may be used for the treatment of Alzheimer's disease.

7.5 Effect on transcription

Hariya (2003) investigated the effect of inhaling odorants (estragon, grapefruit, fennel and pepper oil) on humans and found an increase in relative sympathetic activity (Shen et al., 2005a), which induced noradrenaline release. He found that noradrenaline (0.5 μ g/mL) acted on adipose tissue synergistically with percutaneously absorbed caffeine (1 mM) to promote uncoupling protein-3 gene expression of adipose tissue culture. He proposed that inhaling odorants together with caffeine increase noradrenaline release, expression of uncoupling protein-3, which promotes thermogenesis from free fatty acids produced by the decomposition of neutral fat, inducing a slimming effect.

Liang et al. (2007) studied the time-dependent effects of ethanol intoxication on GABA_A receptor composition and function in rats, and found decreases in the cell-surface fraction of $\alpha 4$ and δ , but not $\alpha 1$, $\alpha 5$, or $\gamma 2$, without changes in their total content. Chronic administration of terpinen-4-ol, α -terpineol or linalool to mice also increased the RNA expression of the $\alpha 4$ subunit, while decreasing that of the $\alpha 1$ subunit as did ethanol, when the expression of mRNAs of GABA_A receptor subunits was examined by the real-time RT-

PCR method (Tasaka & Aoshima, 2010). Change of the composition of GABA_A receptor subunits will influence human mind or consciousness, since GABA_A receptors play an important role in neural transmissions as main inhibitory neurotransmitter receptors and the receptors with different composition of subunits have different pharmacological characteristics (Martin & Olsen, 2000).

8. Fragrances and health

8.1 Homeostasis and the hypothalamus

Basic drives such as stress, sleep, temperature regulation, thirst and hunger are essential for survival (Thompson, 2000). They are aroused when internal conditions are less than optimal. For example, when metabolic energy is insufficient, the organism takes foods and optimizes its conditions. This is the basic notion of homeostasis. These basic motives are controlled by the hypothalamus, which makes up only a small proportion of the limbic system of the brain, but exerts profound effects on behavior and experience. Near the hypothalamus, other neural circuits including the medial forebrain bundle and the nucleus accumbens form a reward system. This common pleasure system in the mammalian brain functions for all basic drives, even that which results from addiction.

The hypothalamus controls the endocrine system, the autonomic nervous system and the immune system (Fig. 17) (Thompson, 2000). These systems interact with each other. Hans Selye developed the notion of a general adaptation syndrome in the 1930s. The basic idea he proposed is that the body shows a common, integrated set of responses in an attempt to adapt to many different kinds of stressors. The stressors are not only physical such as temperature change or hard exercise, but also psychological such as divorce or death in the immediate family. He showed that different severe stressors cause similar bodily harm, that is, enlargement of the adrenal cortex, shriveling of the thymus and lymphatic gland, and hemorrhaging from the stomach's inner wall. He proposed three stages: a shock phase involving decreased blood pressure, body temperature and muscle tone, then an adaptation response (a stage of resistance) when the body fights back, and finally a stage of exhaustion where the body's defenses break down because the stress is severe and continues for a long period. The third stage causes the bodily harm mentioned above, and a marked impairment of the immune system, which possibly causes severe illnesses such as cancer.

The adrenal gland is the major gland for coping with stress in humans. Stressors act on the hypothalamus, which releases corticotrophin-releasing hormone (CRH) and also enhances sympathetic nervous pathways. Then CRH reaches the pituitary, from which adrenocorticotrophic hormone (ACTH) is released into the general circulation. ACTH reaches the adrenal cortex and causes endocrine gland cells there to release cortisol (corticosterone, which is the rat analogue of human cortisol), a stress hormone, and a small amount of aldosterone. Cortisol enhances the sympathetic nervous activity of the autonomic nervous system, which releases noradrenalin as a neurotransmitter at the neuromuscular junctions between the postganglionic sympathetic neurons and smooth or cardiac muscle fibers. The sympathetic nervous pathway also releases adrenalin from adrenal medulla. Thus stressors trigger an arousal mechanism for the entire body, which prepares the animal to "fight or flight" in the face of perceived danger.

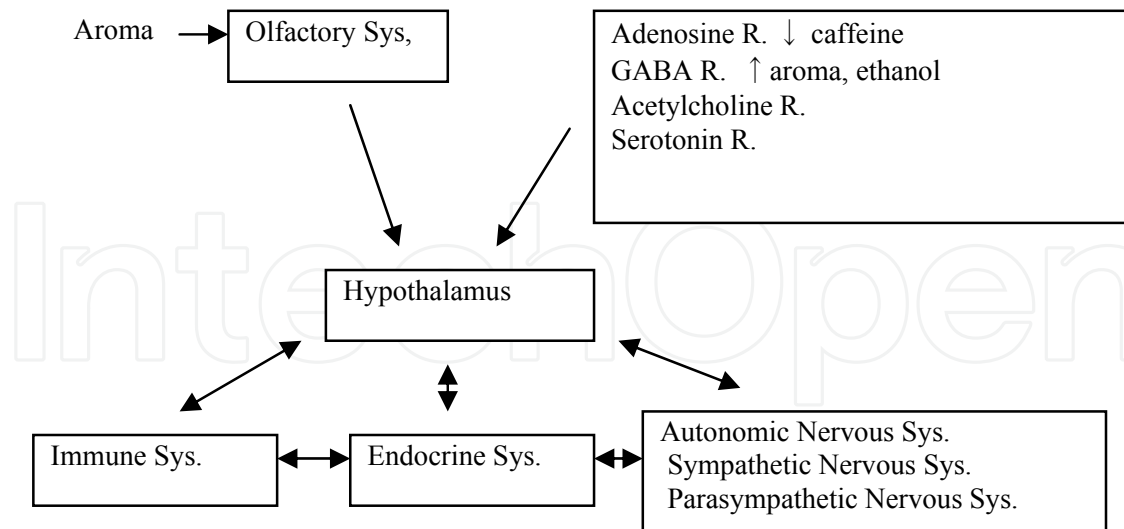

Sys.: system, SNSD: sympathetic nervous system dominant, PNSD: parasympathetic nervous system dominant, R: receptor. ↓: inhibition, ↑: potentiation.

Fig. 17. Schematic representation of interrelations of the olfactory system, the central nervous system, the hypothalamus, and the autonomic nervous, endocrine and immune system and alterations by several food derived components.

8.2 Relationship between stress and health

It has been known for many years that performances in various learning and skill tasks have an inverted-U relation to degree of arousal in both humans and other animals. If you are exhausted or very sleepy, your performances will be poor. If you are aroused properly at some intermediate level of stress, your performances will be optimum. However, if you are extremely aroused under a great deal of stress, your performances will deteriorate. In general, performance is impaired in proportion to the severity of stress *i.e.* the right side of the inverted U (Fig. 18) (Thompson, 2000).

Health, physicality and mentality also have an inverted-U relation to degree of stress or arousal (Fig. 18). It is important to maintain a balance between the sympathetic and parasympathetic nervous systems for optimum health. It is also important to keep a balance between granulocyte and lymphocyte numbers in the immune system. Immune function is affected by both the autonomic nervous system and the endocrine system. If the sympathetic nervous system dominates over the parasympathetic system for long periods, granulocyte numbers increase, while lymphocyte numbers decrease, which is likely to induce inflammation or even cancer (Ben-Elivahu. et al., 2007). Granulocytes destroy bacteria through phagocytosis, but produce reactive oxygen species, which may injure nearby cells and could cause inflammation. On the other hand, if the sympathetic nervous system is less dominant than the parasympathetic system for long periods, granulocyte numbers decrease, while lymphocyte numbers increase. Lymphocytes such as natural killer cells are very important to remove cancer cells. However, they can cause allergies when produced in excess. It is important to maintain homeostasis for our physical and mental health.

8.3 Fragrance and health

Mental and physical relaxation is particularly necessary on busy, stressful days. Reportedly, fragrances such as essential oil of lavender, linalool and whiskey enhanced the parasympathetic nervous system in rats by stimulating the olfactory system (Niiijima et al., 2009; Shen et al., 2005b). Many fragrant compounds such as terpinen-4-ol and ethanol potentiate the response of GABA_A receptors when they are incorporated into the brain, having tranquilizing, anti-anxiety and anti-stress effects (Aoshima et al., 2001; Wallner et al., 2003). So drinking whiskey or beer enhances the parasympathetic nervous system and causes relaxation even sedation. Herbal teas rich in fragrant compounds may induce similar effects. These beneficial activities will be enhanced even more when combined with other activities such as walking in a forest, massage with essential oils, light sports, bathing at mild temperature, listening to healing music or the intake of a balanced diet.

On the other hand, fragrances such as essential oils of grapefruit and limonene enhance sympathetic nervous activity through the olfactory system (Shen et al., 2005a). Active compounds such as caffeine in tea and coffee, and capsaicin in red pepper also enhance the sympathetic nervous system via the autonomic nervous system. Caffeine and polyphenols such as catechins in tea or chlorogenic acid in coffee inhibited the response of GABA_A receptors (Hossain et al., 2007). On the other hand, Bouayed et al. (2007) have found that intraperitoneally injection of mice by chlorogenic acid resulted in anxiolytic effects. They have also found that chlorogenic acid protected granulocytes from oxidative stress. Fruits and coffees may provide health-promoting advantages to consumers, since chlorogenic acid is one of the most abundant polyphenols in coffees and fruits such as plums, apples and cherries.

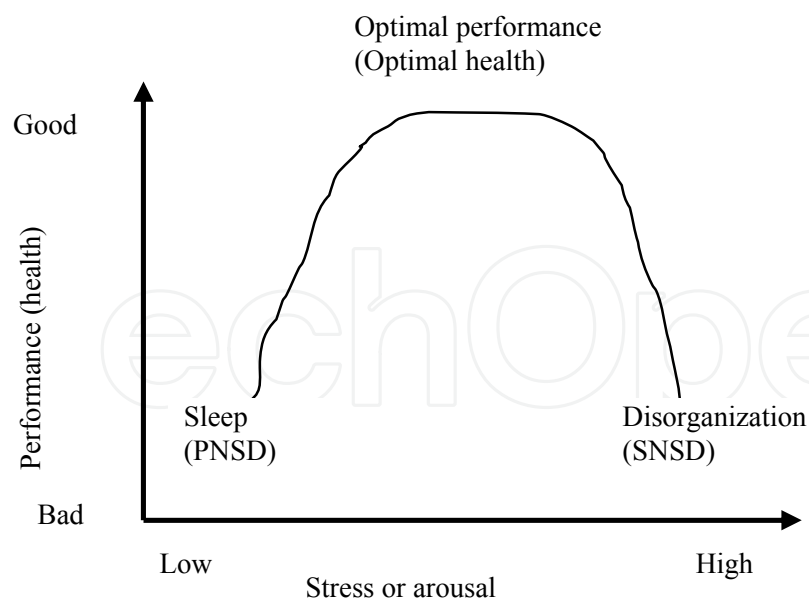

Fig. 18. The inverted-U function relating stress or arousal to performance and health.

Thus, these beverages are useful when we are very sleepy. The relationships among stressors, the autonomic nervous system, the immune system and GABA_A receptors are summarized in Table 5.

Increase	Stressor	Decrease
Sympathetic N. S. dominant	Autonomic N.S.	Parasympathetic N.S. dominant
Fright, anxiety	Situation	Laugh, peace
Granulocyte increase	Leukocyte	Lymphocyte increase
Increase	Reactive oxygen species	Decrease
Inflammation, cancer	Ills caused by excess	Allergy
Muscle	Increase of blood flow	Digestive organs
Increase	Energy consumption	Decrease
Decrease	Body weight	Increase
Limonene	Fragrance	Linalool
Suppression	GABA _A receptor response	Potentiation

Abbreviation used; N.S.: nervous system

Table 5. Stress, autonomic nervous system, immune system and GABA_A receptor.

9. Conclusion

Fragrant compounds and their physiological activities have been made use of since ancient times. However, relevant scientific studies have been slow to emerge, since these activities are very weak. In the last twenty years, studies on the olfactory system have developed extensively since olfactory receptors were clarified at a molecular level. Fragrant compounds bind to olfactory receptors in olfactory sensory neurons and produce smell images in the olfactory bulb, which are analyzed by the brain. These smell images influence the amygdale and hippocampus in the limbic system, which play an important role in emotion and memory, respectively. The signals through the olfactory system are also transferred to the hypothalamus, which controls the autonomic nervous, endocrine and immune systems. Terpens and higher alcohols such as leaf alcohols produced by trees and grasses or flavors from foods possibly induce attractive feelings for humans, while bad odors such as ammonia and hydrogen sulfide cause evasive behaviors. Thus odors affect mental state and emotion as well as peripheral systems. On the other hand, fragrant compounds are incorporated into the blood stream through the skin, lung, stomach and intestines. Since most are hydrophobic, they cross the blood-brain barrier, enter the brain and are possibly accumulated there. Many of them potentiate the response of GABA_A receptors and induce mental relaxation. Some of them inhibit acetylcholine esterase or affect the immune system directly.

Beverages such as tea, coffee and liquor contain physiologically active compounds such as caffeine and ethanol, which can cause addiction. Moreover, they contain flavors, which stimulate the olfactory system. Many of these flavors come from the beverage's raw materials, such as tea leaves, coffee beans, fruits or grain, others come from additives such as flowers or hops, or storage in oak barrels. Some flavors are produced during processing, such as crumpling and drying for teas, roasting for coffee, and fermentation for liquors. These flavors affect emotion and consciousness together with other active compounds and play an important role in a beverage's qualities. Fragrant compounds in beverages may

enhance the effects of active components such as caffeine. Fragrant compounds in liquors increase the potentiation of GABA_A receptors together with ethanol, and induce mental relaxation. On the other hand, flavors in tea and coffee may increase the arousal activity of caffeine, whose mechanism has not been clarified yet. Thus, beverages are useful for balancing the autonomic nervous system in terms of sympathetic and parasympathetic activity, which will help to maintain homeostasis and health. It is necessary to clarify the physiological activities of fragrant compounds at concentrations used under physiological conditions. Essential oils such as lavender, tea tree or eucalyptus have already been used for medical aromatherapy.

10. Acknowledgment

I thank my students and co-researchers, especially Prof. S. J. Hossain in Khulna University, and Dr. H. Koda and Dr. Y. Kiso in Suntory Ltd., for co-operation of these experiments.

11. References

- Aoshima, H. & Hamamoto, K. (1999). Potentiation of GABA receptors expressed in *Xenopus* oocytes by perfume and phytoncid. *Biosci Biotechnol Biochem* 63: 743-8
- Aoshima, H., Hossain, S.J., Hamamoto, K. et al. (2001). Kinetic analyses of alcohol-induced potentiation of the response GABA_A receptors composed of α 1 and β 1 subunits. *J Biochem*, 130: 703-9
- Aoshima, H., Hossain, S.J., Imamura, H. & Shingai, R. (2001). Effects of bisphenol A and its derivatives on the response of GABA_A receptors expressed in *Xenopus* oocytes. *Biosci. Biotechnol Biochem*, 65, 2070-7
- Aoshima, H., Hossain, S.J., Koda, H. & Kiso, Y. (2008). Beer and GABA receptors, In *Beer in Health and Disease Prevention*, Preedy, V.R. & Watson, R.R. (Eds.). pp. 193-201. Academic Press (Elsevier), ISBN 978-0123738912, London, UK
- Aoshima, H., Oda, K., Orihara, Y. et al. (2009). Effects of essential oils on the response of GABA_A receptors, sleeping time in mice induced by a sleeping drug and plasma adrenocorticotrophic levels of rats. *Aroma Res*, 10, 58-64
- Aoshima, H., Takeda, K., Okita, Y. et al. (2006). Effects of beer and hop on ionotropic γ -aminobutyric acid receptors. *J Agric Food Chem*, 54, 2514-19
- Aoshima, H. & Tenpaku, Y. (1997). Modulation of GABA receptors expressed in *Xenopus* oocytes by 13-L-hydroperoxylinoleic acid and food additives. *Biosci Biotechnol Biochem*, 61, 2051-7
- Ben-Elivahu, S., Page, G.G. & Schleifer, S.J. (2007). Stress, NK cells, and cancer: Still a promissory note. *Brain Behav Immun*, 21, 881-7
- Bouayed, J., Rammal, H., Dicko, A., Younos, C. & Soulimani, R. (2007) Chlorogenic acid, a polyphenol from *Prunus domestica* (Mirabelle), with coupled anxiolytic and antioxidant effects. *J Neurol Sci*, 262, 77-84.
- Buck, L.B. (2000). The molecular architecture of odor and pheromone sensing in mammals. *Cell*, 100, 611-8
- Buck, L. & Axel, R.A. (1991). A novel multigene family may encode odorant receptors: a molecular basis for odor recognition. *Cell*, 65, 175-87

- Cal, K. (2006). Skin penetration of terpenes from essential oils and topical vehicles. *Planta Med*, 72, 311-6
- Carey, A.F., Wang, G., Su, C.Y., Zwiebel, L.J. & Carlson, J.R. (2010). Odorant reception in the malaria mosquito *Anopheles gambiae*. *Nature*, 464, 66-72
- Chebib, M. & Johnston, G.A.R. (2000). GABA-activated ligand gated ion channels: medicinal chemistry and molecular biology. *J Med Chem*, 43, 1427-47
- Chu, S. & Dawnes, J.J. (2000) Review; Odour-evoked Autobiographical memories: Psychological investigations of Proustian Phenomena. *Chem Senses*, 25, 111-6
- Chuyen, N.V. & Ishikawa, T. (Eds.). (2008). *Science and function of coffee*. IK Co, Tokyo, Japan ISBN 978-4874922538
- Dayawansa, S., Umeno, K., Takakura, H. et al. (2003). Autonomic responses during inhalation of natural fragrance of Cedrol in humans. *Auton Neurosci*, 108, 79-86
- Dewick. P.M. (2002). *Medicinal Natural Products*. 2ed ed., John Wiley & Sons, ISBN 978-0470741672, Oxford, UK
- Field, T., Diego, M., Hernandez-Reif, M. et al. (2005). Lavender fragrance cleansing gel effects on relaxation. *Int J Neurosci*, 115, 207-22
- Franks, N.P. & Lieb, W.R. (1994). Molecular and cellular mechanisms of general anaesthesia. *Nature*, 367, 507-14
- Fujiwara, R., Komori, T., Noda, Y. et al. (1998). Effect of a long-term inhalation of fragrances on the stress-induced immunosuppression in mice. *Neuroimmunomodulation*, 5, 318-22
- Hariya, T. (2003). The possibility regulating the function of adipose cells by odorants. *Aroma Res*, 6, 72-8
- Hatanaka, A. (1993). The biogenesis of green odour by green leaves. *Phytochemistry*, 35, 1201-18
- Hess, G.P., Cash, D.J. & Aoshima, H. (1983). Acetylcholine receptor-controlled ion translocation: chemical kinetic investigations of the mechanism. *Ann Rev of Biophys Bioeng*, 12, 443-73
- Hongratanaworakit, T. & Buchbauer, G. (2006). Relaxing effect of ylang ylang oil on humans after transdermal absorption. *Phytother Res*, 20, 758-63
- Hossain, S.J. & Aoshima, H. (2008). Fragrant compounds in foods and beverages enhance the GABA_A receptor response, In: *Amino Acid Receptor Research*, Paley, B.F. & Warfield, T.E. (Eds.). pp. 269-291, Nova Science Pub Inc, New York, USA ISBN 978-1604562835
- Hossain, S.J., Aoshima, H., Koda, H. & Kiso, Y. (2002a). Potentiation of the inotropic GABA receptor response by whiskey fragrance. *J Agric Food Chem*, 50, 6828-34
- Hossain, S.J., Aoshima, H., Koda, H. & Kiso, Y. (2003). Effects of coffee components on the response of GABA_A receptor expressed in *Xenopus* oocytes. *J Agric Food Chem*, 51, 7568-75
- Hossain, S.J., Aoshima, H., Koda, H. & Kiso, Y. (2004). Fragrances in oolong tea that enhance the response of GABA_A receptor. *Biosci Biotechnol Biochem*, 68, 1842-8
- Hossain, S.J., Aoshima, H., Koda, H. & Kiso, Y. (2007). Review of functional studies of beverage components acting on the recombinant GABA_A neuroreceptor, and Na⁺/glucose cotransporter-response using the *Xenopus* oocyte expression system and electrophysiological measurements. *Food Biotechnol*, 21, 237-70

- Hossain, S.J., Hamamoto, K., Aoshima, H. & Hara, Y. (2002b). Effects of tea components on the response of GABA_A receptor expressed in *Xenopus* oocytes. *J Agric Food Chem*, 50, 3954-60
- Inoue, S. (2002). *Microorganisms and Aroma*, Flagrance Journal Ltd., ISBN 4-89479-057-2, Tokyo, Japan
- Inoue, N., Kuroda, K., Sugimoto, A., Kakuda, T. & Fushiki, T. (2003). Autonomic nervous responses according to preference for the odor of jasmine tea. *Biosci Biotechnol Biochem*, 67, 1206-14
- Johnson, B.A., Farahbod, H. & Leon, M. (2005). Interactions between odorant functional group and hydrocarbon structure influence activity in glomerular response modules in the rat olfactory bulb. *J Comp Neurol*, 483, 205-16
- Johnston, G.A.R., Hanrahan, J.R., Chebib, M. et al. (2006). Modulation of ionotropic GABA receptors by natural products of plant origin. *Advances in Pharmacol*, 54, 285-316
- Julius, D. & Katz, L.C. (2004). A Nobel for smell. *Cell*, 119, 747-52
- Kobayakawa, K., Kobayakawa, R., Matsumoto, H. et al. (2007). Innate versus learned odor processing in the mouse olfactory bulb. *Nature*, 450, 503-50
- Koda, H., Hossain, S.J., Kiso, Y. & Aoshima, H. (2003). Aging of whiskey increases the potentiation of GABA_A receptor response. *J Agric Food Chem*, 51, 5238-44
- Komori, T., Fujiwara, R., Tanida, M., Nomura, J. & Yokoyama, M.M. (1995). Effect of citrus fragrance on immune function and depressive state. *Neuroimmunomodulation*, 2, 174-80
- Kurahashi, T. & Menini, A. (1997). Mechanism of odorant adaptation in the olfactory receptor cell. *Nature*, 385, 725-9
- Kurihara, H. (1993). Enhancement of the behavioral toxicity induced by combined administration of ethanol with methylxanthines: evaluation by discrete avoidance in mice. *J Toxicol Sci*, 18, 95-101
- Kurihara, H., Asami, T. Ida, I. & Tadokoro S. (1992). Characteristics of the ambulation-increasing effect of the noncompetitive NMDA antagonist MK-801 in mice: assessment by the coadministration with central-acting drugs. *Jpn J Pharmacol*, 58, 11-8
- Kuroda, K., Inoue, N., Ito, Y., et al. (2005). Sedative effects of the jasmine tea odor and (R)-(-)-linalool, one of its major odor components, on autonomic nerve activity and mood states. *Eur J Appl Physiol*, 95, 107-14
- Li, Q., Kobayashi, M., Wakayama, Y. et al. (2009). Effect of phytoncide from trees on human natural killer cell function. *Int J Immunopathol Pharmacol*, 22, 951-9
- Li, Q., Morimoto, K., Kobayashi, M. et al. (2008) A forest bathing trip increases human natural killer activity and expression of anti-cancer proteins in female subjects. *J Biol Regul Homeost Agents*, 22, 45-55
- Li, Q., Nakadai, A., Matsushima, H. et al. (2006) Phytoncides (wood essential oils) induce human natural killer cell activity. *Immunopharmacol Immunotoxicol*, 28, 319- 33
- Liang, J., Suryanarayanan, A., Abriam, A. et al. (2007). Mechanisms of reversible GABA_A receptor plasticity after ethanol intoxication. *J Neurosci*, 27, 12367-77
- Linster, C., Menon, A.V., Singh, C.Y. & Wilson, D.A. (2009). Odor-specific habituation arises from interaction of afferent synaptic adaptation and intrinsic synaptic potentiation in olfactory cortex. *Learn Mem*, 16, 452-9

- Maarse, H. (Ed.). (1991). *Volatile compounds in foods and beverages*. Marcel Dekker Inc, ISBN 0-8247-8390-5, New York, USA
- Martin, D.L. & Olsen, R.W. (Eds.). (2000). *GABA the Nervous System: The View at Fifty Years*. Lippincott Williams & Wilkins, ISBN 0-7817-2267-5, Philadelphia, USA
- Matsui, K. (2006). Green leaf volatiles: hydroperoxide lyase pathway of oxylipin metabolism. *Curr Opin in Plant Biol* 9, 274-80
- Mihic, S.J., Ye, Q., Wick, M.J. et al. (1997). Sites of alcohol and volatile anesthetic action on GABA_A and glycine receptors. *Nature*, 389, 385-9
- Miyazawa, M., Watanabe, H. & Kameoka, H. (1997). Inhibition of acetylcholinesterase activity by monoterpenoids with a *p*-menthene skeleton. *J Agric Food Chem*, 45, 677-9
- Miyazawa, M. & Yamafuji, C. (2005). Inhibition of acetylcholinesterase activity by tea tree oil and constituent terpenoids. *Flavour Fragr J*, 20, 617-20
- Mubassara, S., Ushijima, A., Tan, N. & Aoshima, H. (2008). Effects of essential oils on the response of GABA_A receptors and sleeping time in mice induced by a sleeping drug. *Aroma Res*, 9, 257-63
- Nagashima, T. (2010). *Herbal tea*. Fraegurance Journal Ltd., ISBN 978-4-89479-189-3, Tokyo, Japan
- Nakashima, T., Akamatsu, M., Hatanaka, A. & Kiyohara, T. (2004). Attenuation of stress-induced elevations in plasma ACTH level and body temperature in rats by green odor. *Physiol Behav*, 80, 481-8
- Nicholls, D. G. (1994). *Proteins, Transmitters and Synapses*. Blackwell Scientific Publications, ISBN 0-632-03661-3, Oxford, UK
- Nijijima, A. (2008). Effect of scent stimulation on the autonomic nervous system and metabolic regulation of lipids: physiological base of aromatherapy. *Jiritushinnkei (Autonomic nervous system)*, 45, 178-86
- Nijijima, A., Koda, H., Kiso, Y. & Nagai, K. (2009). Moduration of autonomic nerve activity by whiskey aroma. *Aroma Res*, 10, 256-9
- Patapoutian, A., Peier, A.M., Story, G.M. & Viswanath, V. (2003). ThermoTRP channels and beyond: mechanisms of temperature sensation. *Nat Rev Neurosci*, 4, 529-39
- Sasabe, T., Kobayashi, M., Kondo, Y. et al. (2003). Activation of the anterior cingulate gyrus by 'Green Odor': a positron emission tomography study in the monkey. *Chem Senses*, 28, 565-72
- Schellenberg, R., Sauer, S., Abourashed, E.A., Koetter, U. & Brattström, A. (2004). The fixed combination of valerian and hops (Ze91019) acts via a central adenosine mechanism. *Planta Med*, 70, 594-7
- Semmelhack, J.L. & Wang, J.W. (2009). Select *Drosophila* glomeruli mediate innate olfactory attraction and aversion. *Nature*, 459, 218-23
- Shen, J., Nijijima, A., Tanida, M. et al. (2005a). Olfactory stimulation with scent of grapefruit oil affects autonomic nerves, lipolysis and appetite in rats. *Neurosci lett*, 380, 289-94
- Shen, J., Nijijima, A., Tanida, M. et al. (2005b). Olfactory stimulation with scent of lavender oil affects autonomic nerves, lipolysis and appetite in rats. *Neurosci lett*, 383, 188-93
- Shepherd, G.M. (2000). Smell images and the flavour system in the human brain. *Nature*; 444, 316-21
- Stewart, W.B., Kauer, J.S. & Shepherd, G.M. (1979). Functional organization of rat olfactory bulb analyzed by the 2-deoxyglucose method. *J Comp Neurol*, 185, 715-34

- Takahashi, Y.K., Nagayama, S. & Mori, K. (2004). Detection and masking of spoiled food smells by odor maps in the olfactory bulb. *J Neurosci*, 24, 8690-4
- Takeuchi, H., Ishida, H., Hikichi, S. & Kurahashi, T. (2009). Mechanism of olfactory masking in the sensory cilia. *J Gen Physiol*, 133, 583-600
- Tanida, M., Nijima, A., Shen, J. et al. (2005). Olfactory stimulation with scent of essential oil of grapefruit affects autonomic neurotransmission and blood pressure. *Brain Res*, 1058, 44-55
- Tasaka, T. & Aoshima, H. (2010). Effect of monoterpene alcohols on the expression of subunits in the brain of mice. *Aroma Res*, 11, 110-6
- Thompson, R.F. (2000). *The brain* (third edition), Worth Pub., ISBN 0-7167-3226-2, New York, USA
- Tsang, H.W. & Ho, T.Y. (2010). A systematic review on the anxiolytic effects of aromatherapy on rodents under experimentally induced anxiety models. *Rev Neurosci*, 21, 141-52
- Tsuchiya, T., Tanida, M., Uenoyama, S. & Nakayama, Y. (1992). Effects of olfactory stimulation with jasmine and its component chemicals on the duration of pentobarbital-induced sleep in mice. *Life Sci*, 50, 1097-102
- Turner, S.L. & Ray, A. (2009). Modification of CO₂ avoidance behaviour in *Drosophila* by inhibitory odorants. *Nature*, 461, 277-81
- Uesato, S., Taniguchi, K., Kumagai, A. et al. (2003). Inhibitory effects of 3-O-acyl-(+)-catechins on Epstein-Barr virus activation. *Chem Pharm Bull*, 51, 1448-50
- Umezu, T. (1999). Anti-conflict effects of plant-derived essential oils. *Pharmacol Biochem Behav*, 64, 35-40
- Umezu, T. (2000). Behavioral effects of plant-derived essential oils in the Geller type conflict test in mice. *Jpn J Pharmacol*, 83, 150-3
- Umezu, T. (2009). Evidence for dopamine involvement in ambulation promoted by menthone in mice. *Pharmacol Biochem Behav*, 91, 315-20
- Umezu, T., Sakata, A. & Ito, H. (2001). Ambulation-promoting effect of peppermint oil and identification of its active constituents. *Pharmacol Biochem Behav*, 69, 383-90
- Vignes, M., Maurice, T., Lante, F. et al. (2006) Anxiolytic properties of green tea polyphenol (-)-epigallocatechin gallate (EGCG). *Brai Res*, 1110, 102-15
- Wada, M. & Yamazaki, K. (Eds.). (2004). *Aroma and Medicine*, Fragrance Journal Ltd., ISBN 978-4894790766, Tokyo, Japan
- Wallner, M., Hancher, H.J. & Olsen, R.W. (2003). Ethanol enhances $\alpha_4\beta_3\delta$ and $\alpha_6\beta_3\delta$ γ -aminobutyric acid type A receptors at low concentrations known to affect humans. *Proc Natl Acad Sci USA*, 100, 15218-23
- Xu, F., Liu, N., Kida, I. et al. (2003). Odor maps of aldehydes and esters revealed by functional MRI in the glomerular layer of the mouse olfactory bulb. *Proc Natl Acad Sci USA*, 100, 11029-34
- Yamada, K., Miura, T., Mimaki, Y. & Sashida, Y. (1996). Effect of inhalation of chamomile oil on plasma ACTH level in ovari-ectomized-rat under restriction stress. *Biol Pharm Bull*, 19, 1244-6
- Yamada, K., Mimaki, Y. & Sashida, Y. (1994). Anticonvulsive effects of inhaling lavender oil vapour. *Biol Pharm Bull*, 17: 359-60
- Yamanishi, S. (1992) *Science of tea*, Shokabo, ISBN 978-4- 7853-8567-5, Tokyo, Japan

- Yatagai, M. (2010). *Physiological activities of plant aroma*, Fragrance Journal Ltd., ISBN 978-4-89479-184-8, Tokyo, Japan
- Yokogoshi, H. (Ed.). (2006). *Development and perspectives of anti-stress food*. CMC Pub. Co., ISBN 4-88231-589-0, Tokyo, Japan
- Yoshimura, H. (2006). The potential of caffeine for functional modification from cortical synapses to neuron networks in the brain. *Curr Neuropharmacol*, 3, 309-16
- Zanoli, P., Rivasi, M., Zavatti, M., Brusiani, F. & Baraldi, M. (2005). New insight in the neuropharmacological activity of *Humulus lupulus* L. *J Ethnopharmacol*, 102, 102-6

IntechOpen

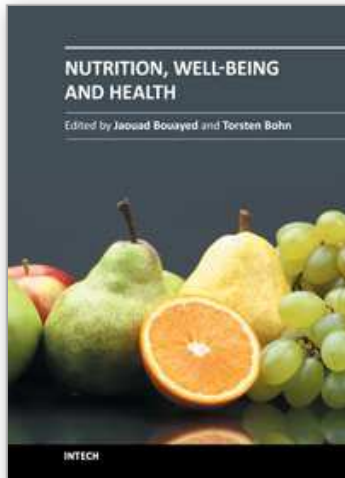

Nutrition, Well-Being and Health

Edited by Dr. Jaouad Bouayed

ISBN 978-953-51-0125-3

Hard cover, 224 pages

Publisher InTech

Published online 23, February, 2012

Published in print edition February, 2012

In our modern society, expectations are high, also with respect to our daily diet. In addition to being merely "nutritious", i.e. supplying a variety of essential nutrients, including macro-nutrients such as proteins or micro-nutrients such as minerals and vitamins, it is almost expected that a good diet offers further advantages - especially well-being and health and the prevention of chronic diseases, which are, as we generally tend to grow older and older, becoming a burden to enjoying private life and to the entire society. These additional qualities are often sought in diets rich also in non-nutritive components, such as phytochemicals. In contrast to drugs, which are taken especially to cure or ameliorate diseases, it is expected that a healthy diet acts in particular on the side of prevention, allowing us to become old without feeling old. In the present book, rather than trying to give an exhaustive overview on nutritional aspects and their link to well-being and health, selected topics have been chosen, intended to address presently discussed key issues of nutrition for health, presenting a reasonable selection of the manifold topics around diet, well-being, and health: from the antioxidants polyphenols and carotenoids, aroma-active terpenoids, to calcium for bone health, back to traditional Chinese Medicine.

How to reference

In order to correctly reference this scholarly work, feel free to copy and paste the following:

Hitoshi Aoshima (2012). Beneficial Effects of Fragrances in Beverages on Human Health, Nutrition, Well-Being and Health, Dr. Jaouad Bouayed (Ed.), ISBN: 978-953-51-0125-3, InTech, Available from:
<http://www.intechopen.com/books/nutrition-well-being-and-health/beneficial-effects-of-fragrances-in-beverages-on-human-health>

INTECH
open science | open minds

InTech Europe

University Campus STeP Ri
Slavka Krautzeka 83/A
51000 Rijeka, Croatia
Phone: +385 (51) 770 447
Fax: +385 (51) 686 166
www.intechopen.com

InTech China

Unit 405, Office Block, Hotel Equatorial Shanghai
No.65, Yan An Road (West), Shanghai, 200040, China
中国上海市延安西路65号上海国际贵都大饭店办公楼405单元
Phone: +86-21-62489820
Fax: +86-21-62489821

© 2012 The Author(s). Licensee IntechOpen. This is an open access article distributed under the terms of the [Creative Commons Attribution 3.0 License](#), which permits unrestricted use, distribution, and reproduction in any medium, provided the original work is properly cited.

IntechOpen

IntechOpen