

We are IntechOpen, the world's leading publisher of Open Access books Built by scientists, for scientists

4,800

Open access books available

122,000

International authors and editors

135M

Downloads

Our authors are among the

154

Countries delivered to

TOP 1%

most cited scientists

12.2%

Contributors from top 500 universities

**WEB OF SCIENCE™**Selection of our books indexed in the Book Citation Index
in Web of Science™ Core Collection (BKCI)

Interested in publishing with us?
Contact book.department@intechopen.com

Numbers displayed above are based on latest data collected.
For more information visit www.intechopen.com



Recent Advances in Pharmacogenomic Technology for Personalized Medicine

Toshihisa Ishikawa and Yoshihide Hayashizaki
*Omics Science Center, RIKEN Yokohama Institute,
Japan*

1. Introduction

Genetic polymorphisms and mutations in drug metabolizing enzymes, transporters, receptors, and other drug targets (*e.g.*, toxicity targets) are linked to inter-individual differences in the efficacy and toxicity of many medications as well as risk of genetic diseases. Validation of clinically important genetic polymorphisms and the development of new technologies to rapidly detect clinically important variants are critical issues for advancing personalized medicine.

Pharmacogenomics, which deals with heredity and response to drugs, is the scientific field that attempts to explain individual variability of drug responses and to search for the genetic basis of such variations or differences (Evans et al., 2001). The inter-individual variation in the rate of drug metabolism has been known for many years. Initially, the study of pharmacogenetics was only of academic interest, but today it is of major concern to the pharmaceutical industry as a means for documenting the metabolism of a new drug in development before registration. The knowledge of how a drug is metabolized and which enzymes are involved may help to predict drug-drug interactions and the rate at which individual patients may metabolize a specific drug. Such information is now required for registration by the U.S. Food and Drug Administration (FDA) and similar authorities (Salerno & Lesko, 2004a, 2004b). To improve drug safety, the FDA has started to update the labels and package inserts of previously approved drugs as new clinical and genetic evidence accrues (Frueh et al., 2008; Lesko, 2008).

The current important step is to incorporate pharmacogenomics data into routine clinical practice. As a means of implementing personalized medicine, it is critically important to understand the molecular mechanisms underlying inter-individual differences in the drug response, namely, pharmacological effect vs. side effect. The occurrence of personal variations in the response to a drug may result from many different causes, for example, genetic variations and expression levels of drug-targeted molecules, including membrane receptors, nuclear receptors, signal transduction components, and enzymes, as well as those of drug-metabolizing enzymes and drug transporters (Evans et al., 2001). Recently, tools such as next-generation sequencing technologies and genome-wide association studies (GWAS) have been used to uncover a number of variants that affect drug toxicity and efficacy as well as potential risk of diseases. The costs involved in carrying out GWAS and

sequencing have been dropping dramatically, while providing data at an unprecedented rate. The GWAS approach has been applied for identifying genetic contributions to variations in drug response (The SEARCH Collaborative Group, 2008; Kamatani et al., 2010; Cooper et al., 2008; Schuldiner et al., 2009; Ge et al., 2009; Daly et al., 2009). As a result, there have been dramatic increases in our understanding of the mechanisms of drug action and of the genetic determinants responsible for variable responses to both rarely and widely used drugs, such as warfarin, tomozifen, and clopidogrel.

Technologies are evolving to transform diagnostic devices for rapid genetic testing. Portable devices are being engineered for use in a range of settings to perform robust assays for the diagnosis of disease that will improve patient management, and result in greater convenience and speed to answer. The genetic diagnostics is a growing field that is gradually becoming more user-friendly with the introduction of portable devices and quicker nucleic acid detection. Successful genetic diagnostics require 4 major elements, such as rapid reaction, low cost, low energy consumption, and simple analysis (with minimal technical training and inclusion of controls but no off-instrument processing or reagent preparation). In this context, we decided to develop a point-of-care "POC" technology and to apply it to medical advances.

Development of personalized medicine including POC technology requires integration of various segments of biotechnology, clinical medicine, and pharmacology. A key requirement for advancing personalized medicine is the ability to rapidly and conveniently test for patients' genetic polymorphisms and/or mutations. To address this urgent need, we have recently developed a rapid and cost-effective method, named Smart Amplification Process (SmartAmp), which enables us to detect genetic polymorphisms or mutations in target genes within 30 to 45 minutes under isothermal conditions that do not require DNA isolation and PCR amplification (Mitani et al., 2007; Mitani et al., 2009; Ishikawa et al., 2010; Aw et al., 2011; Ota et al., 2010; Lezhava et al., 2010; Toyoda et al., 2009; Aomori et al., 2009; Watanabe et al., 2007; Okada et al., 2010; Azuma et al., 2011). In this book chapter, we will present the technological development and clinical applications of the SmartAmp method.

2. SmartAmp method

The SmartAmp method was developed based on the principal concept that DNA amplification itself is the signal for detection of a genetic mutation or SNP. Differing from the widely-used PCR, the SmartAmp method is an isothermal DNA amplification reaction (Mitani et al., 2007; Mitani et al., 2009). In the SmartAmp method, the entire DNA amplification process requires five primers: turnback primer (TP), boost primer (BP), folding primer (FP), and two outer primers (OP1 and OP2) (Fig. 1). Primers are selected based on those algorithms considering the free energy, probability of base-pairing, product size range, optimal melting temperature, and product size range. The design of these primers contributes to the specificity of SmartAmp. In particular two primers (TP and FP) are critically important for the amplification process. The genomic sequence between the annealing sites of the TP and FP primers is the target region that will be amplified by the SmartAmp reaction. The other primers (BP, OP1, and OP2) are additionally employed to accelerate the process and enhance specificity.

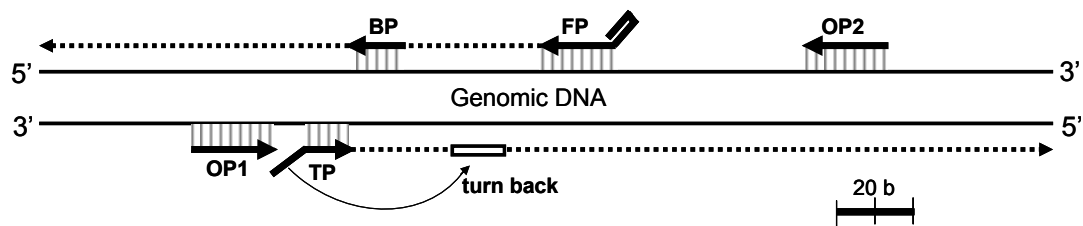

Fig. 1. Schematic illustration of five primers used for the SmartAmp method: turn-back primer (TP), boost primer (BP), folding primer (FP), and two outer primers (OP1 and OP2)

2.1 Molecular mechanism underlying isothermal DNA amplification

In isothermal DNA amplification by the SmartAmp method, the initial step of copying a target sequence from the genomic DNA is a prerequisite. FP and TP hybridize the template genomic DNA. Next, both products primed for the FP and TP are detached from template genomic DNA by strand-displacing DNA polymerase, whose extensions are primed by OP1 and OP2. Single-stranded DNA products, thus displaced, become templates in the second step for the opposing FP and TP. These single stranded DNA products are generated by the strand-displacement activity of the DNA polymerase, being primed from the flanking region of OP primers adjacent to the target sequence. The resulting DNA products are referred to as "intermediate products", IM1 and IM2, which play key roles in the subsequent amplification steps (Fig. 2).

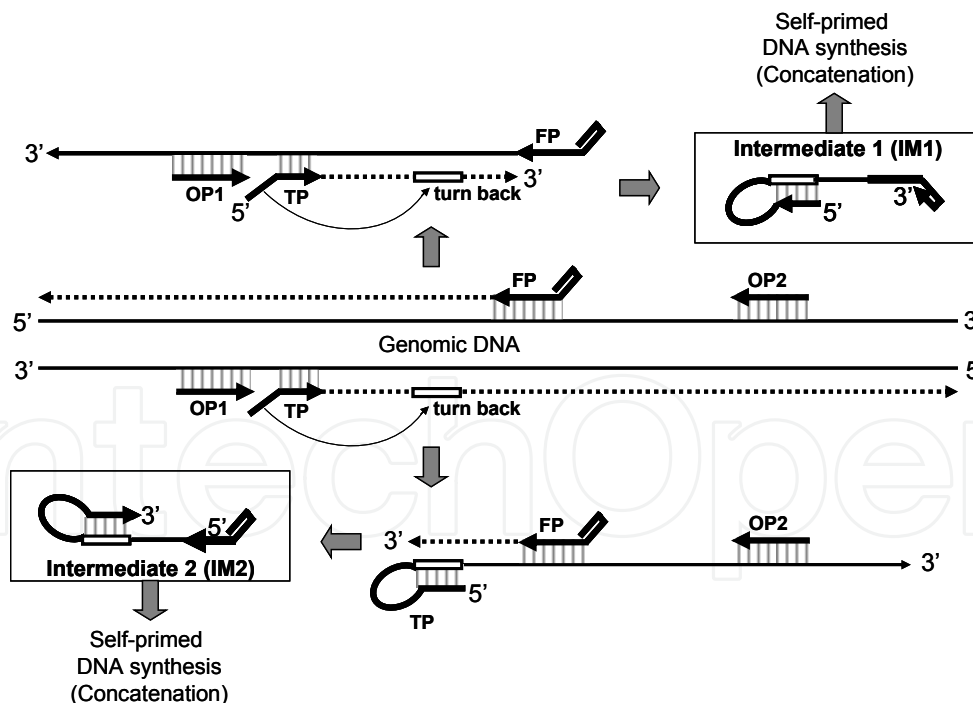

Fig. 2. Formation of intermediate products in the initial step of the SmartAmp reaction. The priming events of the SmartAmp reaction generate two intermediates (i.e., IM1 and IM2).

The formation of those intermediate products (IM1 and IM2) is the rate-limiting step in SmartAmp-based isothermal DNA amplification. IM1 has the TP sequence at the 5' end and the FP complementary sequence at the 3' end; and IM2 is complementary to IM1 (Fig. 3).

The initial self-priming site on IM1 is the 3'-end of the FP sequence of IM1. Concatenated products of IM1 are synthesized by an elongation process termed pathway A. The characteristic feature of the products of pathway A is that the free 5' and 3' ends carry TP and its complementary sequence, forming long double stranded hairpin DNA. The initial self-priming elongation site on IM2 is located at the 3' end of the TP sequence of IM2. Long concatenated DNA products are synthesized as in pathway A, but end products in pathway B are different. The long-hairpin DNA products of pathway B carry FP and its complementary sequence at the free 5' and 3' ends respectively. There is another elongation pathway which starts from the 3' end of a free TP-primer that hybridizes to the looping structure of the TP complementary sequence, which is located at the intermediate region of the long products of pathway A. Thus, concatenated DNA products are formed in the SmartAmp reaction. The resulting DNA products could be detected by conventional agarose gel electrophoresis, where DNA ladder patterns represented the formation of concatenated DNA products (Mitani et al., 2007) (Fig. 3).

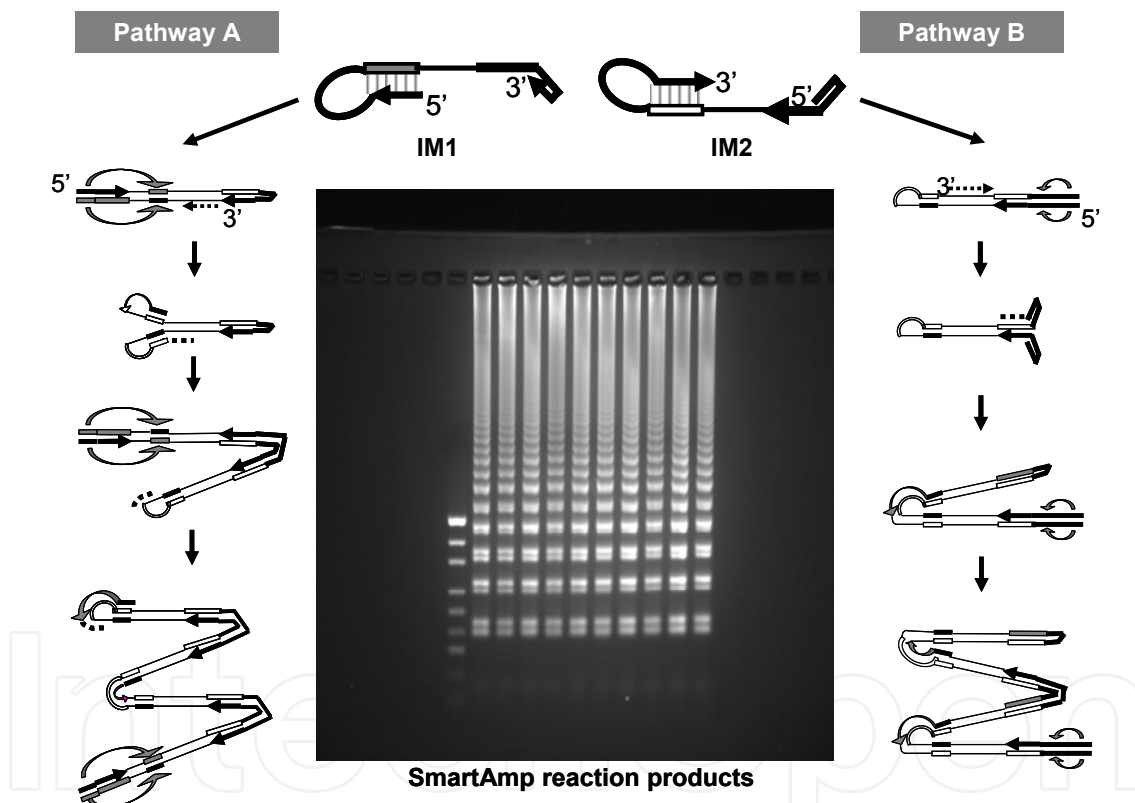

Fig. 3. The molecular mechanism underlying isothermal DNA amplification. Formation of concatenated DNA products in the SmartAmp reaction. Self-priming DNA synthesis from each of the intermediates, IM1 and IM2, creates hairpin molecules via pathway A or B. These structures lead to further self-primed DNA synthesis to create dimeric amplicons and then subsequently concatenated DNA products.

2.2 Molecular mechanism underlying SNP detection

To ensure the high fidelity of SNP detection by the SmartAmp method, exponential amplification of mis-primed DNA must be suppressed. In the original SmartAmp method,

this was achieved by adding either the mismatch binding protein (MutS) *Thermus aquaticus* (Mitani et al., 2009) or a competitive probe (Toyoda et al., 2009) to the reaction mixture. MutS inhibits background DNA from entering the amplification cycle by specifically binding to mis-primed amplification products (Fig. 4). In addition, a combination of the asymmetrical primers, *i.e.*, TP and FP is used to minimize alternative mis-amplification pathways (Mitani et al., 2007).

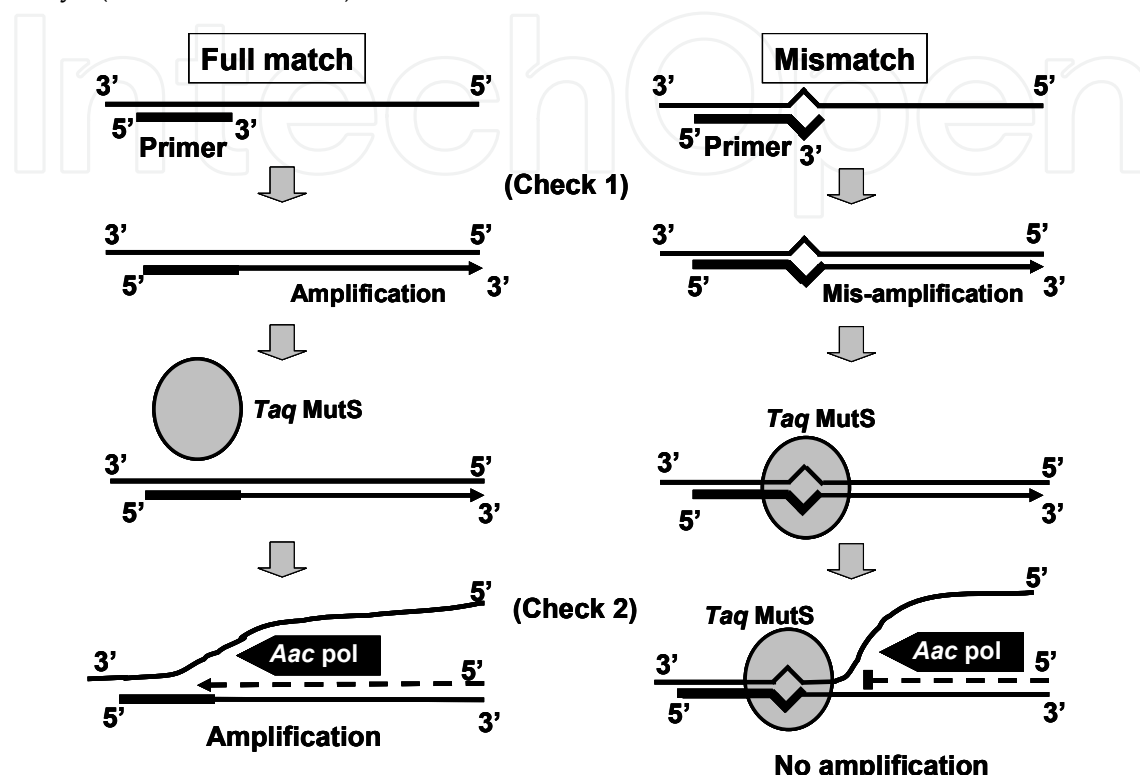

Fig. 4. The mechanism of allele discrimination as exercised by *Taq MutS*. SNP typing with a wild-type allele detection primer, using the wild-type allele (left) and the mutant-type allele (right) as templates. The wild-type allele detection primer is designed to encompass the SNP nucleotide site at each 3'-position. Amplification is not allowed when the primer mismatches with the mutant-type allele (Check 1). If check 1 fails, *Taq MutS* strongly binds to mismatched nucleotides and *Aac* DNA polymerase can not strand-displace or extend the newly synthesized strand (Check 2).

The SmartAmp method utilizes *Aac* polymerase as a DNA polymerase with strand-displacement activity. This DNA polymerase is highly resistant to cellular contaminants and hence works directly on blood samples, just after a simple heat treatment (98°C, 3 min) to degrade RNA and denature proteins. This is a great advantage of the SmartAmp method over the commonly used PCR-based techniques that require careful DNA extraction. In the conventional method, the enzymatic activity of *Taq* DNA polymerase is easily inhibited by impurities.

2.3 Example of SNP detection by SmartAmp method

Clinical application of SmartAmp to practical SNP detection should be evaluated with clinical samples (either blood or genomic DNA) according to the principle of amplification versus non-amplification as compared to threshold values. The amount of DNA-

intercalating SYBR Green I dye during the reaction can be monitored in a real-time PCR system (e.g., Mx3000P), and thereby SNP typing can be determined by referring to the intensity of fluorescence.

Each SmartAmp2 reaction is performed in a 25 μ l-volume tube at 60°C. The standard reaction mixture contains 3.2 μ M each of TP and FP, 0.4 μ M each of OP1 and OP2, 1.6 μ M BP, 1.4 mM dNTPs, 5% dimethyl sulfoxide (DMSO), 20 mM Tris-HCl (pH 8.8), 10 mM KCl, 10 mM (NH₄)₂SO₄, 8 mM MgSO₄, 0.1% Tween 20, SYBR Green I (1/100,000-diluted), 40 units of *Aac* DNA polymerase, 1.5-2.4 μ g of *Taq* MutS (optional) and 1 μ l of blood or genomic DNA sample. Each reaction mixture should be incubated at 60°C for 40 - 60 minutes under isothermal conditions in a real-time PCR model Mx3000P system (Stratagene, La Jolla, CA, USA) where changes in the fluorescence intensity of SYBR Green I dye is monitored to detect the DNA amplification. Fig. 5 presents the results of the SmartAmp method when applied to detection of a clinically important SNP 460G>A in exon 7 of the human thiopurine S-methyltransferase (*TPMT*) gene. Clinical importance of this SNP will be discussed in the following section.

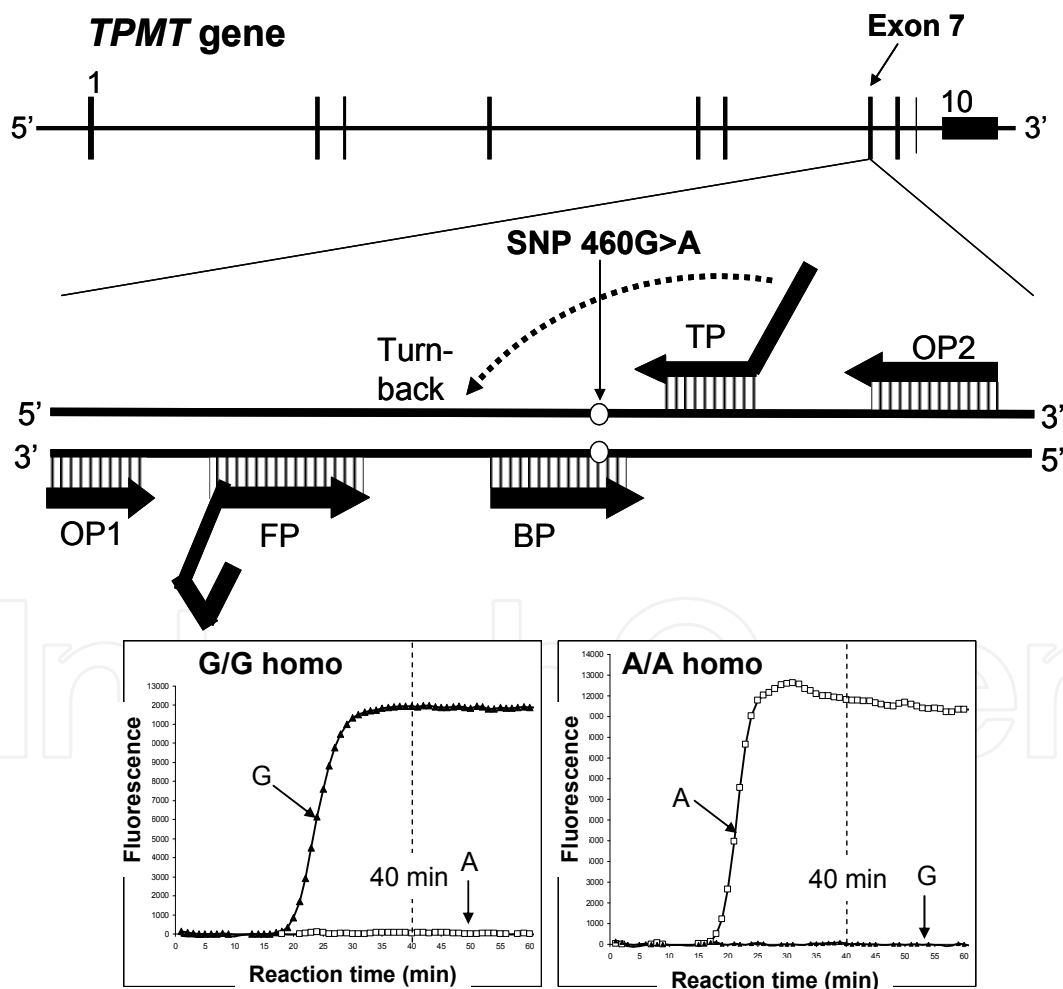

Fig. 5. Schematic illustration of the human *TPMT* gene and detection of the SNP 460G>A by the SmartAmp method. Two panels depict the time-courses of the SmartAmp assay reactions with *TPMT*-specific primers carrying WT (460G) or SNP (460A) alleles; namely, G/G homozygote and A/A homozygote.

3. Clinical applications of SmartAmp method

Hitherto, we have proven that the SmartAmp method is capable of detecting SNPs in drug transporter genes (*e.g.*, *ABCB1*, *ABCG2*, and *ABCC11*) (Ishikawa et al., 2010; Aw et al., 2011; Ota et al., 2010; Toyoda et al., 2009) as well as in drug metabolizing enzyme genes, including those of cytochrome P450s, vitamin K epoxide reductase (*VKORC1*), and UDP-glucuronosyltransferase *UGT1A1* (Aomori et al., 2009; Watanabe et al., 2007). Here we present other examples of SNP detection by the SmartAmp method, namely detection of genetic polymorphisms in human *TPMT* and *ABCC4* genes to predict thiopurine-induced adverse reactions in certain sub-populations of patients.

3.1 Thiopurine toxicity and genetic polymorphisms in *TPMT* gene

Thiopurines are effective immunosuppressants and anticancer agents used for treating childhood acute lymphoblastic leukemia, acute myeloblastic leukemia, autoimmune disease, rheumatoid arthritis, and inflammatory bowel diseases. The intracellular accumulation of such active metabolites as 6-thioguanine nucleotides (6-TGN), however, causes dose-limiting hematopoietic toxicity (Weinshilboum & Sladek, 1980). *TPMT* deficiency has been reported to exacerbate thiopurine toxicity (Fig. 6).

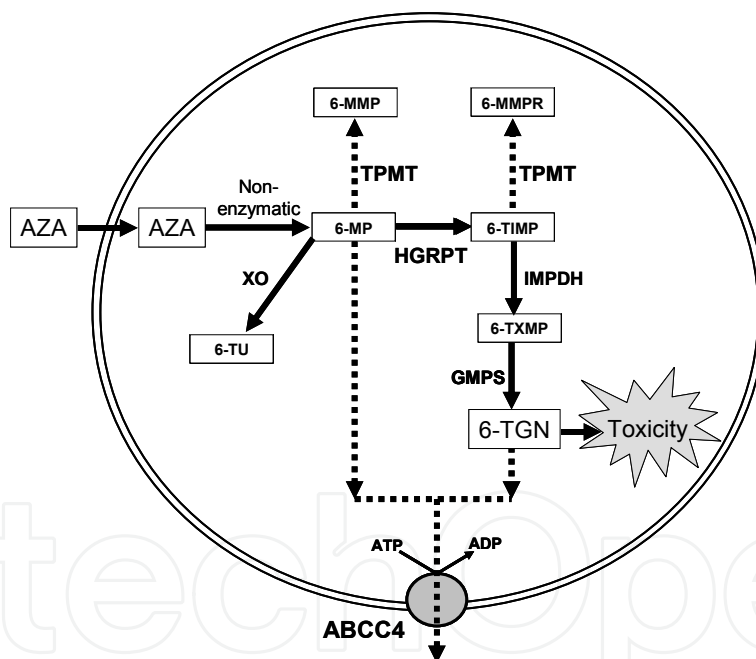

Fig. 6. Cellular metabolism of azathioprine (AZA) and transport. HGRPT, hypoxanthine-guanine phosphoribosyl transferase; IMPDH, inosine monophosphate dehydrogenase; XO, xanthine oxidase. 6-MMP, 6-methylmercaptopurine; 6-MMPR, 6-methylmercaptopurine ribonucleosides; 6-MP, 6-mercaptopurine; 6-TGN, 6-thioguanine nucleotide; 6-TIMP, 6-thiosine 5'-monophosphate; 6-TU; 6-thiouric acid; 6-TXMP, 6-thioxanthosine monophosphate; GMPS, guanosine monophosphate synthetase; 6-TGN, 6-thioguanine nucleotides. AZA is non-enzymatically converted to 6-MP in the cell. HGRPT is responsible for conversion of 6-MP to 6-TIMP. Thiopurine toxicity is caused by cellular accumulation of 6-TGN. Human ABC transporter *ABCC4* plays a role of extruding the cytotoxic 6-TGN from the cells.

The enzyme TPMT operates in the main inactivation pathway for thiopurine drugs. The *TPMT* gene comprising 10 exons is located on chromosome 6p22.3 (Fig. 7). TPMT activity has been proven by numerous studies to be inversely correlated to 6-TGN levels in erythrocytes and other hematopoietic tissues (Krynetski et al., 1995; Evans, 2004; Anstey et al., 1992; Stolk et al., 1998; Yates et al., 1997; Black et al., 1998; Clunie et al., 2004). Polymorphisms in the *TPMT* gene can lead to intermediate, low, or no TPMT activity in certain patients, who are thus at an increased risk of developing thiopurine-induced life-threatening hematologic toxicity. Therefore, the thiopurine dose should be reduced by 50% for intermediate and by 80 to 90% for poor metabolizers to reduce the toxicity risk. There are a total of 24 functionally related alleles that have been reported to date, i.e., *TPMT**1 to *18 and *20 to *23 (Schütz et al., 2000; Schaeffeler et al., 2008; Lee et al., 2008). *TPMT**1 is the wild-type allele with high enzymatic activity. The *TPMT**2 allele has one non-synonymous SNP of 238G>C (Ala80Pro). The *TPMT**3A allele carries two non-synonymous SNPs of both 460G>A (Ala154Thr) and 719A>G (Tyr240Lys), while the *TPMT**3B and *TPMT**3C alleles each carry one non-synonymous SNP of 460G>A (Ala154Thr) and 719A>G (Tyr240Lys), respectively. While *TPMT**2 is the first variant allele described, this allele is much less common than *TPMT**3A. Population studies have shown that approximately 10% of Caucasians and African Americans inherit one non-functional *TPMT**3A allele. This non-functional allele is not commonly seen in Asians. In Korean populations, *TPMT**3C (0.88-2.54%) and *6 (0.25-1.27%) were found to some extents (Schaeffeler et al., 2008; Lee et al., 2008). Tai *et al.* reported that enhanced degradation of TPMT allozymes encoded by the *TPMT**2 and *TPMT**3 alleles is the mechanism for the decreased levels of TPMT protein and enzyme activity inherited as a result of these alleles (Tai et al., 1997). Subsequently, Wang *et al.* have demonstrated that the rapid degradation of TPMT*3A involves molecular chaperones, such as the heat shock proteins hsp70 and hsp90, and that TPMT*3A can also form intracellular aggresomes (Wang et al., 2003; Wang et al., 2005; Wang & Weinshilboum, 2006).

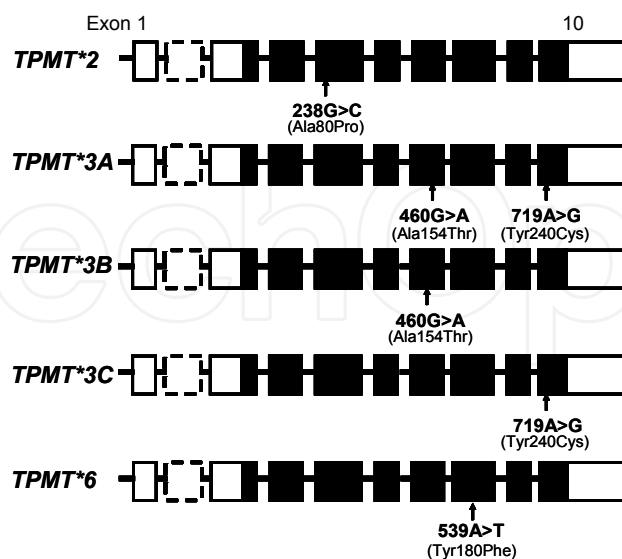

Fig. 7. The genomic organization of the human *TPMT* gene and five different alleles, i.e., *TPMT**2, *TPMT**3A, *TPMT**3B, *TPMT**3C, and *TPMT**6. Non-synonymous SNPs of 238G>C (Ala80Pro), 460G>A (Ala154Thr), 539A>T (Tyr180Phe), and 719A>G (Tyr240Cys) are indicated by arrows.

3.2 SNP 2269G>A (Glu757Lys) in *ABCC4* gene and thiopurine toxicity

For largely unknown reasons, there are subsets of Japanese patients who suffer from dose-limiting hematopoietic toxicity, but are not *TPMT* deficient (Takatsu et al., 2009). Recent studies have revealed that *ABCC4* protects against thiopurine-induced hematopoietic toxicity by actively exporting thiopurine nucleotides (Krishnamurthy et al., 2008; Ban et al., 2010). *ABCC4* is reportedly involved in the transport of antiviral agents, such as azidothymidine, adefovir, tenofovir, lamivudine, and ganciclovir (Shuetz et al., 1999; Adachi et al., 2002; Anderson et al., 2006; Imaoka et al., 2007), as well as anticancer drugs including 6-MP, 6-TG, methotrexate, and the camptothecins (Lee et al., 2000; Chen et al., 2002; Wielinga et al., 2002; Tian et al., 2005).

ABCC4 is a highly polymorphic gene with more than 20 missense genetic variants identified in the National Centre for Biotechnology Information (NCBI) database and the Pharmacogenetics Research Network (PGRN). Despite this situation, few data are available regarding the functions of these variants. Krishnamurthy *et al.* have recently shown that patients carrying SNP 2269G>A (Glu757Lys) in the human *ABCC4* gene have severely reduced *ABCC4* function resulting from an impairment of its cell membrane localization (Krishnamurthy et al., 2008). *ABCC4* protects against thiopurine-induced hematologic toxicity by actively exporting 6-TGN, a toxic metabolite in the thiopurine drug metabolic pathway. Interestingly, the *ABCC4* 2269G>A SNP is common in the Japanese population (15 to 18% frequency), which suggests that this non-synonymous SNP could provide an explanation for the unsolved thiopurine toxicity that is not associated with genetic polymorphisms of *TPMT* (Takatsu et al., 2009; Ban et al., 2010; Ando et al., 2001).

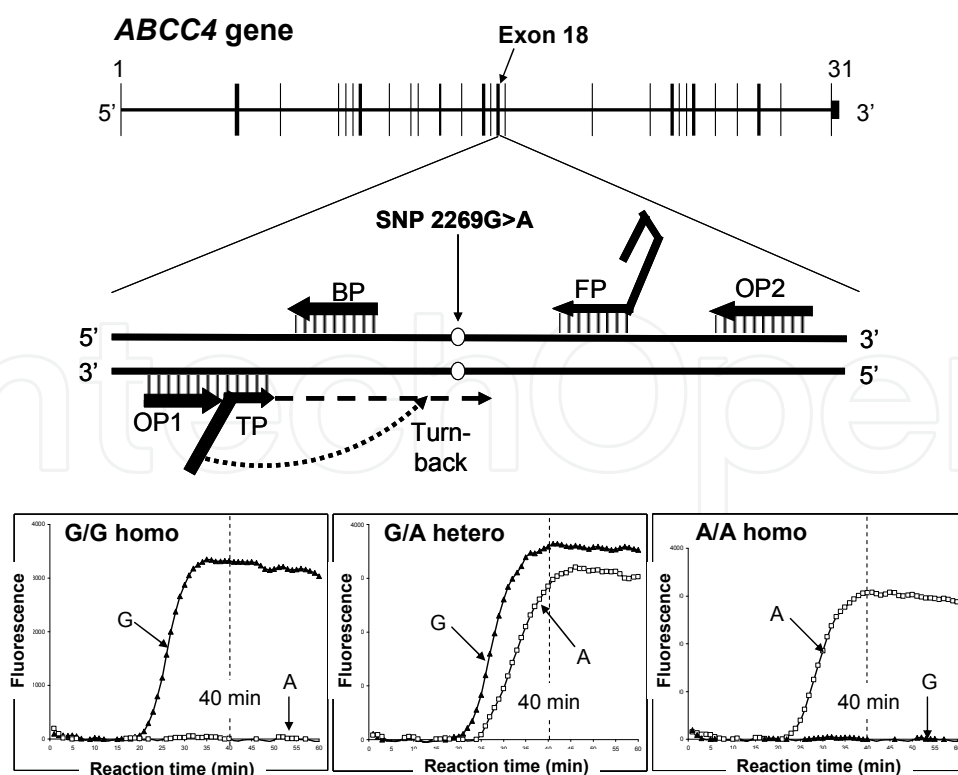

Fig. 8. Schematic illustration of the human *ABCC4* gene located on chromosome 13q32.1. The SNP 2269G>A that resides in exon 18 was detected by the SmartAmp method.

Unlike the situation for *TPMT*, the effects of the 2269G>A polymorphism in the *ABCC4* gene have been relatively unexplored. Most recently, Ban *et al.* have investigated an association between the 2269G>A polymorphism in the *ABCC4* gene and thiopurine sensitivity in Japanese patients with inflammatory bowel disease (IBD) (Ban *et al.*, 2010). A total of 235 samples from IBD patients were analyzed in their clinical study. They showed that the 6-TGN levels in red blood cells were significantly higher in patients with the allele of *ABCC4* SNP 2269G>A than in patients with the wild-type allele ($P = 0.049$). The white blood cell count was significantly lower in patients with the SNP 2269G>A allele than in patients with the wild-type allele. Among 15 patients with leucopenia ($< 3 \times 10^9/l$), seven carried the SNP 2269G>A allele (Ban *et al.*, 2010). The odds ratio of carrying the SNP allele and having leucopenia was 3.33 (95% confidence interval 1.03-10.57, $P = 0.036$) (Ban *et al.*, 2010). As compared with the azathiopurine (AZA) dose of 2 to 3 mg/kg recommended in Western countries (Lichtenstein *et al.*, 2006), lower doses of AZA (0.6 to 1.2 mg/kg) are used in Japan because of the relatively higher sensitivity to AZA (Hibi *et al.*, 2003). Those results strongly suggest that the *ABCC4* SNP 2269G>A is a new diagnostic marker indicative of thioprine toxicity/sensitivity in Japanese patients with IBD. In this context, the SmartAmp method for rapid detection of the *ABCC4* SNP 2269G>A (Fig. 8) provides a practical tool for prediction of thioprine toxicity/sensitivity in Japanese patients with IBD.

4. Conclusion

Accumulating evidence strongly suggests that genetic polymorphisms in drug metabolizing enzymes, transporters, receptors, and other drug targets (e.g., toxicity targets) are linked to inter-individual differences in the efficacy and toxicity of many medications. The genetic polymorphisms of drug metabolizing enzymes and transporters have been studied in many laboratories worldwide. In fact, efforts to discover and characterize gene polymorphisms resulted in new diagnostic tests for discriminating between different gene alleles and better strategies for pharmacotherapy.

To realize the promise of individualized medicine, however, genetic diagnosis should be further integrated with therapy for selecting drugs and treatments as well as for monitoring results. It is also critically important to reduce the cost of genetic diagnosis. Technologies are evolving to transform diagnostic devices for rapid genetic testing. Portable devices are being engineered for use in a range of settings to perform robust assays for the diagnosis of disease that will improve patient management, and result in greater convenience and speed to answer. Indeed, the POC diagnostics is a growing field that is gradually becoming more user-friendly with the introduction of portable devices and quicker nucleic acid detection.

The isothermal amplification technologies have a potential to cover different applications. A key requirement for the advancing personalized medicine resides in the ability of rapidly and conveniently testing patients' genetic polymorphisms and/or mutations. With this respect, isothermal nucleic acid amplification technologies, including the SmartAmp method, are expected to translate into less complex and less expensive instrumentation.

5. Acknowledgment

The authors thank Prof. John D. Schuetz (St. Jude Children's Hospital, Memphis, TN, USA) and Prof. Akira Andoh (Shiga University of Medical Science, Otsu, Japan) for their fruitful

discussion about genetic polymorphisms of human *ABCC4* gene. Our thanks go to Drs. Alexander Lezhava and Wanping Aw (Omics Science Center, RIKEN) for their generous support in SmartAmp-based genotyping experiments. The authors' study was supported by a Japan Science and Technology Agency (JST) research project named "Development of the world's fastest SNP detection system" (to TI) and Research Grant for RIKEN Omics Science Center from the Ministry of Education, Culture, Sports, Science and Technology (to YH).

6. References

- Adachi, M.; Sampath, J.; Lan, L.B.; Sun, D.; Hargrove, P.; Flatley, R.; Tatum, A.; Edwards, M.Z.; Wezeman, M.; Matherly, L.; Drake, R. & Schuetz, J. (2002) Expression of MRP4 confers resistance to ganciclovir and compromises bystander cell killing. *J. Biol. Chem.*, vol. 277, pp. 38998-39004
- Anderson, P.L.; Lamba, J.; Aquilante, C.L.; Schuetz, E. & Fletcher, C.V. (2006) Pharmacogenetic characteristics of indinavir, zidovudine, and lamivudine therapy in HIV-infected adults: a pilot study. *J. Acquir. Immune Defic. Syndr.*, vol. 42, pp. 441-449
- Ando, M.; Ando, Y.; Hasegawa, Y.; Sekido, Y.; Shimokata, K. & Horibe, K. (2001) Genetic polymorphisms of thiopurine S-methyltransferase and 6-mercaptopurine toxicity in Japanese children with acute lymphoblastic leukaemia. *Pharmacogenetics*, vol. 11, pp. 269-273
- Anstey, A.; Lennard, L.; Mayou, S.C. & Kirby, J.D. (1992) Pancytopenia related to azathioprine—an enzyme deficiency caused by a common genetic polymorphism: a review. *J. Royal Soc. Med.*, vol. 85, pp. 752-756
- Aomori, T.; Yamamoto, K.; Oguchi-Katayama, A.; Kawai, Y.; Ishidao, T.; Mitani, Y.; Kogo, Y.; Lezhava, A.; Fujita, Y.; Obayashi, K.; Nakamura, K.; Kohnke, H.; Wadelius, M.; Ekström, L.; Skogastierna, C.; Rane, A.; Kurabayashi, M.; Murakami, M.; Cizdziel, P.E.; Hayashizaki, Y. & Horiuchi, R. (2009) Rapid SNP detection of the cytochrome P-450 (CYP) 2C9 and the vitamin K oxide reductase (VKORC1) gene for the warfarin dose adjustment by Smart-Amplification process vesion 2. *Clin. Chem.*, vol. 55, pp. 804-812
- Aw, W.; Lezhava, A.; Hayashizaki, Y. & Ishikawa, T. (2011) A new trend in personalized medicine: rapid detection of SNPs in drug transporter genes by SmartAmp method. *Clin. Pharmacol. Ther.*, vol. 89, pp. 617-620
- Azuma, K.; Lezhava, A.; Shimizu, M.; Kimura, Y.; Ishizu, Y.; Ishikawa, T.; Kamataki, T.; Hayashizaki, Y. & Yamazaki, H. (2011) Direct genotyping of *cytochrome P450 2A6* whole gene deletion from human blood samples by SmartAmp method. *Clin Chim Acta*, vol. 412, pp. 1249-1251
- Ban, H.; Andoh, A.; Imaeda, H.; Kobori, A.; Bamba, S.; Tsujikawa, T.; Sasaki, M.; Saito, Y. & Fujiyama, Y. (2010) The multidrug-resistance protein 4 polymorphism is a new factor accounting for thiopurine sensitivity in Japanese patients with inflammatory bowel disease. *J. Gastroenterol.*, vol. 45, pp. 1014-1021
- Black, A.J.; McLeod, H.L.; Capell, H.A.; Powrie, R.H.; Matowe, L.K.; Pritchard, S.C.; Collie-Duguid, E.S. & Reid, D.M. (1998) Thiopurine methyltransferase genotype predicts therapy-limiting severe toxicity from azathioprine. *Ann. Internal Med.*, vol. 129, pp. 716-718
- Chen, Z.S.; Lee, K.; Walther, S.; Raftogianis, R.B.; Kuwano, M.; Zeng, H. & Kruh, G.D. (2002) Analysis of methotrexate and folate transport by multidrug resistance protein 4 (ABCC4): MRP4 is a component of the methotrexate efflux system. *Cancer Res.*, vol. 62, pp. 3144-3150

- Clunie, G.P. & Lennard, L. (2004) Relevance of thiopurine methyltransferase status in rheumatology patients receiving azathioprine. *Rheumatology*, vol.43, pp.13-18
- Cooper, G.M.; Johnson, J.A.; Langae, T.Y.; Feng, H.; Stanaway, I.B.; Schwarz, U.I.; Ritchie, M.D.; Stein, C.M.; Roden, D.M.; Smith, J.D.; Veenstra, D.L.; Rettie, A.E. & Rieder, M.J. (2008) A genome-wide scan for common genetic variants with a large influence on warfarin maintenance dose. *Blood*, vol. 112, pp. 1022-1027
- Daly, A.K.; Donaldson, P.T.; Bhatnagar, P.; Shen, Y.; Pe'er, I.; Floratos, A.; Daly, M.J.; Goldstein, D.B.; John, S.; Nelson, M.R.; Graham, J.; Park, B.K.; Dillon, J.F.; Bernal, W.; Cordell, H.J.; Pirmohamed, M.; Aithal, G.P.; Day, C.P.; DILIGEN Study & International SAE Consortium. (2009) HLA-B*5701 genotype is a major determinant of drug-induced liver injury due to flucloxacillin. *Nature Genet.*, vol. 41, pp. 816-819
- Evans, W.E. & Johnson, J.A. (2001) Pharmacogenomics: the inherited basis for interindividual differences in drug response. *Annu. Rev. Genomics Hum. Genet.* vol. 2, pp. 9-39
- Evans, W.E. (2004) Pharmacogenetics of thiopurine S-methyltransferase and thiopurine therapy. *Ther. Drug Monit.* Vol. 26, pp. 185-191
- Frueh, F.W.; Amur, S.; Mummaneni, P.; Epstein, R.S.; Aubert, R.E.; DeLuca, T.M.; Verbrugge, R.R.; Burckart, G.J. & Lesko, L.J. (2008) Pharmacogenomic biomarker information in drug labels approved by the United States food and drug administration: prevalence of related drug use. *Pharmacotherapy*, vol. 28, pp. 992-998
- Ge, D.; Fellay, J.; Thompson, A.J.; Simon, J.S.; Shianna, K.V.; Urban, T.J.; Heinzen, E.L.; Qiu, P.; Bertelsen, A.H.; Muir, A.J.; Sulkowski, M.; McHutchison, J.G. & Goldstein, D.B. (2009) Genetic variation in IL28B predicts hepatitis C treatment-induced viral clearance. *Nature*, vol. 461, pp. 399-401
- Hibi, T.; Naganuma, M.; Kitahara, T.; Kinjyo, F. & Shimoyama, T. (2003) Low-dose azathioprine is effective and safe for maintenance of remission in patients with ulcerative colitis. *J. Gastroenterol.* Vol. 38, pp. 740-746
- Imaoka, T.; Kusuhara, H.; Adachi, M.; Schuetz, J.D.; Takeuchi, K. & Sugiyama, Y. (2007) Functional involvement of multidrug resistance-associated protein 4 (MRP4/ABCC4) in the renal elimination of the antiviral drugs adefovir and tenofovir. *Mol. Pharmacol.*, vol. 71, pp. 619-627
- Ishikawa, T.; Sakurai, A.; Hirano, H.; Lezhava, A.; Sakurai, M. & Hayashizaki, Y. (2010) Emerging new technologies in pharmacogenomics: Rapid SNP detection, molecular dynamic simulation, and QSAR analysis methods to validate clinically important genetic variants of human ABC Transporter ABCB1 (P-gp/MDR1). *Pharmacol. Ther.*, vol. 126, pp. 69-81
- Kamatani, Y.; Matsuda, K.; Okada, Y.; Kubo, M.; Hosono, N.; Daigo, Y.; Nakamura, Y. & Kamatani, N. (2010) Genome-wide association study of hematological and biochemical traits in a Japanese population. *Nat. Genet.*, vol. 42, pp. 210-215
- Krishnamurthy, P.; Schwab, M.; Takenaka, K.; Nachagari, D.; Morgan, J.; Leslie, M.; Du, W.; Boyd, K.; Cheok, M.; Nakauchi, H.; Marzolini, C.; Kim, R.B.; Poonkuzhali, B.; Schuetz, E.; Evans, W.; Relling, M. & Schuetz, J.D. (2008) Transporter-mediated protection against thiopurine-induced hematopoietic toxicity. *Cancer Res.*, vol. 68, pp. 4983-4989
- Krynetski, E.Y.; Schuetz, J.D.; Galpin, A.J.; Pui, C.; Relling, M.V. & Evans, W.E. (1995) A single point mutation leading to loss of catalytic activity in human thiopurine S-methyltransferase. *Proc. Natl. Acad. Sci. USA* vol. 92, pp. 694-702
- Lee, K.; Klein-Szanto, A.J. & Kruh, G.D. (2000) Analysis of the MRP4 drug resistance profile in transfected NIH3T3 cells. *J. Natl. Cancer Inst.*, vol. 92, pp. 1934-1940

- Lee, S.S.; Kim, W.Y.; Jang, Y.J. & Schin, L.G. (2008) Duplex pyrosequencing of the TPMT*3C and TPMT*6 alleles in Korean and Vietnamese populations. *Clin Chem.* Vol. 398, pp. 82-85
- Lesko, L.J. (2008) The critical path of warfarin dosing: finding an optimal dosing strategy using pharmacogenetics. *Clin. Pharmacol. Ther.*, vol. 84, pp. 301-303
- Lezhava, A.; Ishidao, T.; Ishizu, Y.; Naito, K.; Hanami, T.; Katayama, A.; Kogo, Y.; Soma, T.; Ikeda, S.; Murakami, K.; Nogawa, C.; Itoh, M.; Mitani, Y.; Harbers, M.; Okamoto, A. & Hayashizaki, Y. (2010) Exciton Primer-mediated SNP detection in SmartAmp2 reactions. *Hum. Mutat.*, vol. 31, pp. 208-217
- Lichtenstein, G.R.; Sbreu, M.T.; Cohen, R. & Tremaine W. (2006) American Gastroenterological Association Institute technical review on corticosteroids, immunomodulators, and infiximab in inflammatory bowel disease. *Rev. Gastroenterol. Mex.*, vol. 71, pp. 351-401
- Mitani, Y.; Lezhava, A.; Kawai, Y.; Kikuchi, T.; Oguchi-Katayama, A.; Kogo, Y.; Itoh, M.; Miyagi, T.; Takakura, H.; Hoshi, K.; Kato, C.; Arakawa, T.; Shibata, K.; Fukui, K.; Masui, R.; Kuramitsu, S.; Kiyotani, K.; Chalk, A.; Tsunekawa, K.; Murakami, M.; Kamataki, T.; Oka, T.; Shimada, H.; Cizdziel, P.E. & Hayashizaki, Y. (2007) Rapid SNP diagnostics using asymmetric isothermal amplification and a new mismatch-suppression technology. *Nature Methods*, vol. 4, pp. 257-262
- Mitani, Y.; Lezhava, A.; Sakurai, A.; Horikawa, A.; Nagakura, M.; Hayashizaki, Y. & Ishikawa, T. (2009) A rapid and cost-effective SNP detection method: Application of SmartAmp2 to pharmacogenomics research. *Pharmacogenomics*, vol. 10, pp. 1187-1197
- Okada, R.; Ishizu, Y.; Endo, R.; Lezhava, A.; Ieiri, I.; Kusuhara, H.; Sugiyama, Y. & Hayashizaki, Y. (2010) Direct rapid genotyping of glutathione-S-transferase M1 and T1 from human blood specimens using the SmartAmp2 method. *Drug Metab. Dispos.*, vol. 38, pp. 1636-1639
- Ota, I.; Sakurai, A.; Toyoda, Y.; Morita, S.; Sasaki, T.; Chishima, T.; Yamakado, M.; Kawai, Y.; Ishidao, T.; Lezhava, A.; Yoshiura, K.; Togo, S.; Hayashizaki, Y.; Ishikawa, T.; Ishikawa, T.; Endo, I. & Shimada, H. (2010) Association between breast cancer risk and the wild-type allele of human ABC transporter ABCC11. *Anticancer Res.*, vol. 30, pp. 5189-5194
- Salerno, R. & Lesko, L.J. (2004) Pharmacogenomics in drug development and regulatory decision-making: the genomic data submission. *Pharmacogenomics*, vol. 5, pp. 25-30
- Salerno, R. & Lesko, L.J. (2004) Pharmacogenomic data: FDA volutanry and required submission guidance. *Pharmacogenomics*, vol. 5, pp. 503-505
- Schaeffeler, E.; Zanger, U.M.; Eichelbaum, M.; Asante-Poku, S.; Shin, J.-G. & Schwab, M. (2008) Highly multiplexed genotyping of thiopurine S-methyltransferase variants using MALDI-TOF mass spectrometry: reliable genotyping in different ethnic groups. *Clin. Chem.* Vol. 54, pp. 1637-1647
- Schuetz, J.D.; Connelly, M.C.; Sun, D.; Paibir, S.G.; Flynn, P.M.; Srinivas, R.V.; Kumar, A. & Fridland, A. (1999) MRP4: a previously unidentified factor in resistance to nucleoside-based antiviral drugs. *Nature Med.*, vol. 5, pp. 1048-1051
- Schuldiner, A.R.; O'Connell, J.R.; Bliden, K.P.; Gandhi, A.; Ryan, K.; Horenstein, R.B.; Damcott, C.M.; Pakyz, R.; Tantry, U.S.; Gibson, Q.; Pollin, T.I.; Post, W.; Parsa, A.; Mitchell, B.D.; Faraday, N.; Herzog, W. & Gurbel, P.A. (2009) Association of cytochrome P450 2C19 genotype with the antiplatelet effect and clinical efficacy of clopidogrel therapy. *JAMA*, vol. 302, pp. 849-857
- Scchütz, E.; von Ahsen, N. & Oellerich, M. (2000) Genotyping of eight thiopurine methyltransferase mutations: three-color multiplexing, "two-color/shered" anchor, and fluorescence-quenching hybridization probe assays based on thermodynamic nearest-neighbor probe design. *Clin. Chem.*, vol. 46, pp. 1728-1737

- Stolk, J.N.; Boerbooms, A.M.; de Abreu, R.A.; de Koning, D.G.; van Beusekom, H.J.; Muller, W.H. & van de Putte, L.B. (1998) Reduced thiopurine methyltransferase activity and development of side effects of azathioprine treatment in patients with rheumatoid arthritis. *Arthritis Rheum.*, vol. 41, pp. 1858-1866
- Tai, H.L.; Krynetski, E.Y.; Schuetz, E.G.; Yanishevski, Y. & Evans, W.E. (1997) Enhanced proteolysis of thiopurine S-methyltransferase (TPMT) encoded by mutant alleles in humans (TPMT*3A,TPMT*2): mechanism for genetic polymorphisms of TPMT activity. *Proc. Natl. Acad. Sci. USA*, vol. 94, pp. 6444-6449
- Takatsu, N.; Matsui, T.; Murakami, Y.; Ishihara, H.; Hisabe, T.; Nagahama, T.; Maki, S.; Beppu, T.; Takaki, Y.; Hirai, F. & Yao, K. (2009) Adverse reactions to azathioprine cannot be predicted by thiopurine S-methyltransferase genotype in Japanese patients with inflammatory bowel disease. *J. Gastroenterol. Hepatol.*, vol. 24, pp. 1258-1264
- The SEARCH Collaborative Group. (2008) SLCO1B1 variants and statin-induced myopathy - a genomewide study. *New Eng. J. Med.*, vol. 359, pp. 789-799
- Tian, Q.; Zhang, J.; Tan, T.M.; Chan, E.; Duan, W.; Chan, S.Y.; Boelsterli, U.A.; Ho, P.C.; Yang, H.; Bian, J.S.; Huang, M.; Zhu, Y.Z.; Xiong, W.; Li, X. & Zhou, S. (2005) Human multidrug resistance associated protein 4 confers resistance to camptothecins. *Pharm. Res.* Vol. 22, pp. 1837-1853
- Toyoda, Y.; Sakurai, A.; Mitani, Y.; Nakashima, M.; Yoshiura, K.; Nakagawa, H.; Sakai, Y.; Ota, I.; Lezhava, A.; Hayashizaki, Y.; Niikawa, N. & Ishikawa, T. (2009) Earwax, osmidrosis, and breast cancer: why does one SNP (538G>A) in the human ABC transporter ABCC11 gene determine earwax type? *FASEB J.*, vol. 23, pp. 2001-2013
- Wang, L.; Sullivan, W.; Toft, D. & Weinshilboum, R. (2003) Thiopurine S-methyltransferase pharmacogenetics: chaperone protein association and allozyme degradation. *Pharmacogenetics*, vol. 13, pp. 555-564
- Wang, L.; Nguyen, T.V.; McLaughlin, R.W.; Sikkink, L.A.; Ramirwez-Alvarado, M. & Weinshilboum, R. (2005) Human thiopurine S-methyltransferase pharmacogenetics: variant allozyme misfolding and aggresome formation. *Proc. Natl. Acad. Sci. USA*, vol. 102, pp. 9394-9399
- Wang, L. & Weinshilboum, R. (2006) Thiopurine S-methyltransferase pharmacogenetics: insights, challenges and future directions. *Oncogene*, vol. 25, pp. 1629-15638
- Watanabe, J.; Mitani, Y.; Kawai, Y.; Kikuchi, T.; Kogo, Y.; Oguchi-Katayama, A.; Kanamori, H.; Usui, K.; Itoh, M.; Cizdziel, P.E.; Lezhava, A.; Tatsumi, K.; Ichikawa, Y.; Togo, S.; Shimada, H. & Hayashizaki, Y. (2007) Use of a competitive probe in assay design for genotyping of the UGT1A1*28 microsatellite polymorphism by the smart amplification process. *Biotechniques*, vol. 43, pp. 479-484
- Weinshilboum, R.M. & Sladek, S.L. (1980) Mercaptopurine pharmacogenetics: monogenic inheritance of erythrocyte thiopurine methyltransferase activity. *Am. J. Hum. Genet.*, vol. 32, pp. 651-662
- Wielinga, P.R.; Reid, G.; Challa, E.E.; van der Heijden, I.; van Deemter, L.; de Haas, M.; Mol, C.; Kuil, A.J.; Groeneveld, E.; Schuetz, J.D.; Brouwer C, De Abreu, R.A.; Wijnholds, J.; Beijnen, J.H. & Borst, P. (2002) Thiopurine metabolism and identification of the thiopurine metabolites transported by MRP4 and MRP5 overexpressed in human embryonic kidney cells. *Mol. Pharmacol.*, vol. 62, pp. 1321-1331
- Yates, C.R.; Krynetski, E.Y.; Loennechen, T.; Fessing, M.Y.; Tai, H.L.; Pui, C.H.; Relling, M.V. & Evans, W.E. (1997) Molecular diagnosis of thiopurine S-methyltransferase deficiency: genetic basis for azathioprine and mercaptopurine intolerance. *Ann. Internal Med.*, vol. 126, pp. 608-614

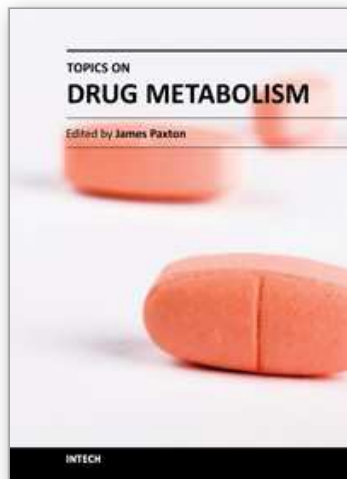

Topics on Drug Metabolism

Edited by Dr. James Paxton

ISBN 978-953-51-0099-7

Hard cover, 294 pages

Publisher InTech

Published online 22, February, 2012

Published in print edition February, 2012

In order to avoid late-stage drug failure due to factors such as undesirable metabolic instability, toxic metabolites, drug-drug interactions, and polymorphic metabolism, an enormous amount of effort has been expended by both the pharmaceutical industry and academia towards developing more powerful techniques and screening assays to identify the metabolic profiles and enzymes involved in drug metabolism. This book presents some in-depth reviews of selected topics in drug metabolism. Among the key topics covered are: the interplay between drug transport and metabolism in oral bioavailability; the influence of genetic and epigenetic factors on drug metabolism; impact of disease on transport and metabolism; and the use of novel microdosing techniques and novel LC/MS and genomic technologies to predict the metabolic parameters and profiles of potential new drug candidates.

How to reference

In order to correctly reference this scholarly work, feel free to copy and paste the following:

Toshihisa Ishikawa and Yoshihide Hayashizaki (2012). Recent Advances in Pharmacogenomic Technology for Personalized Medicine, Topics on Drug Metabolism, Dr. James Paxton (Ed.), ISBN: 978-953-51-0099-7, InTech, Available from: <http://www.intechopen.com/books/topics-on-drug-metabolism/recent-advances-in-pharmacogenomic-technology-for-personalized-medicine>

INTECH
open science | open minds

InTech Europe

University Campus STeP Ri
Slavka Krautzeka 83/A
51000 Rijeka, Croatia
Phone: +385 (51) 770 447
Fax: +385 (51) 686 166
www.intechopen.com

InTech China

Unit 405, Office Block, Hotel Equatorial Shanghai
No.65, Yan An Road (West), Shanghai, 200040, China
中国上海市延安西路65号上海国际贵都大饭店办公楼405单元
Phone: +86-21-62489820
Fax: +86-21-62489821

© 2012 The Author(s). Licensee IntechOpen. This is an open access article distributed under the terms of the [Creative Commons Attribution 3.0 License](#), which permits unrestricted use, distribution, and reproduction in any medium, provided the original work is properly cited.

IntechOpen

IntechOpen