

# We are IntechOpen, the world's leading publisher of Open Access books Built by scientists, for scientists

**4,800**

Open access books available

**122,000**

International authors and editors

**135M**

Downloads

Our authors are among the

**154**

Countries delivered to

**TOP 1%**

most cited scientists

**12.2%**

Contributors from top 500 universities



**WEB OF SCIENCE™**

Selection of our books indexed in the Book Citation Index  
in Web of Science™ Core Collection (BKCI)

Interested in publishing with us?  
Contact [book.department@intechopen.com](mailto:book.department@intechopen.com)

Numbers displayed above are based on latest data collected.

For more information visit [www.intechopen.com](http://www.intechopen.com)



# The Serology Diagnostic Schemes in *Borrelia burgdorferi* Sensu Lato Infections – Significance in Clinical Practice

Małgorzata Tokarska-Rodak and Maria Koziół-Montewka  
Department of Medical Microbiology, Medical University, Lublin  
Poland

## 1. Introduction

Lyme borreliosis is a world-wide multi-organic disease caused by spirochete *Borrelia burgdorferi* sensu lato. Numerous gene-species *Borrelia* are identified with a various frequency in Europe, Asia and America (Ruderko, et al., 2009; Siegel, et al., 2008; Stanek G, 2011; Wilske, et al., 2007 Wodecka, 2006a). Within the last few years, as well as in Europe as in North America, there were prepared strategies, directives and guidelines for diagnostics and treatment of Lyme disease, including the frequency of occurrence of specific gene-species and a specification of clinical symptoms (Center for Disease Control and Prevention [CDC], 2011; European Concerted Action on Lyme Borreliosis [EUCALB], 2008). Lyme disease seems to be easy to diagnose and treat due to the pathogenic factor known for a long-time and elaborated diagnostic and therapeutic schemas. In serological diagnostics an impediment constitutes a wide range of genospecies *B. burgdorferi*, changes of expression of particular genes occurring in various stages of an infection, and cross reactions which occur in the presence of other pathogenic microorganisms and disease entities connected with an immune response disorders. It is connected with the necessary use of appropriately configured diagnostic tests and recombinant proteins common for particular genospecies and related to the immunological response at different stages of the infection (EUCALB, 2008; Zajkowska, et al., 2006a,2006b). As well as a diagnostician as a doctor has to consider not only the results of the serological tests but also numerous, coexisting, frequently unspecified factors in order to make an accurate diagnose confirming or excluding *B. burgdorferi* infection. In many cases, even early and accurate diagnosis and antibiotic therapy appropriately applied does not guarantee the effective eradication of a pathogen, and what is important for a patient - a complete elimination of symptoms of the disease. Post-treatment Lyme disease Syndrome (PTLDS) has been confirmed in some patients - it is a complex of lingering, unspecified clinical symptoms which impede a complete physical and mental recovery in patients after being treated from Lyme disease. This is a crucial problem as well as in health as in social life which is frequently ignored. The symptoms concerning Lyme arthritis and neuroborreliosis are frequently the cause of an immense disability in patients in numerous life activities and it is required to undertake a rehabilitation program (Tokarska-Rodak et al., 2007).

## 2. Two-step laboratory testing process in diagnostics of Lyme disease

European Concerted Action on Lyme Borreliosis (EUCALB) and Center for Disease Control and Prevention (CDC) recommend a two-step testing process in serological diagnostics of Lyme disease (CDC, 2011; EUCALB, 2008). It has been assumed that, a diagnosis of every form of clinical disease, except erythema migrans (EM), requires the two-step testing process. The first step in the testing process uses enzyme immunoassay techniques: Indirect Immunofluorescence Assay (IFA) or Enzyme Linked Immunosorbent Assay (ELISA) in order to detect the presence of specific antibodies IgM and/or IgG (in relation to the stage of illness). ELISA or IFA tests should be confirmed by immunoblotting (Western blot, Wb). In other European countries and the USA a two test procedure is recommended: a sensitive screening test such as ELISA supported by immunoblot. All specimens positive or equivocal by a ELISA or IFA should be tested by a standardized Western blot. Specimens negative by a sensitive ELISA or IFA need not be tested further. It was recommended that an IgM immunoblot be considered positive if two of the following three bands are present - OspC, (24 kDa), BmpA (39 kDa) and Flagelina (41 kDa). It was further recommended that an IgG immunoblot be considered positive if bands for antigen proteins are present: p17, p18, p21 (DbpA), OspC (p22, 23, 24, 25), OspD (p29), p30, OspA (p31), OspB (p34), p58, p83/100 and VlsE (Aberer, 2007; Deutsche Borreliose-Gesellschaft e.V, 2010; EUCALB, 2008, MMWR, 1995). Complete standardization of immunoblotting protocols in Europe is unrealistic at present. Lyme borreliosis is not the same in all geographic areas due to different local prevalence of species and strains of *B. burgdorferi* s.l. and to heterogeneity within those strains. Recommendations for the interpretation of Western blots have not always been applicable to populations in geographic areas other than where they were developed. The development of immunoblots using defined recombinant or synthetic antigens is promising for the future (EUCALB, 2008; Robertson, 2000).

The test for Lyme disease (ELISA, IFA, Western blot) measures antibodies made by white blood cells in response to infection. The antibodies IgM are produced in human's body in the response against the antigen proteins *B. burgdorferi* in the 2nd-4th week since the EM exposure, reaching the ultimate in the 4th-6th week, and they are most frequently IgM anti-OspC and anti-p41. If the serological test is made too soon, it can show falsely negative results in the scope of the presence of IgM because of the low symptomatic features. Antibody response in early Lyme borreliosis may be weak or absent, especially in erythema migrans and antibiotic treatment may abrogate antibody production. Serology may also be negative in acute neuroborreliosis with short duration of the disease (EUCALB, 2008; Stanek, 2011). The repetition of Wb after 2-4 weeks should be considered in patients at an early stage in case of a positive result of an enzyme immunoassay test and negative confirmation test (Depietropaolo, et al., 2005; EUCALB, 2008; Flisiak& Pancewicz, 2011; Przytuła, et al., 2006). When Western blot is used during the first 4 weeks of disease onset (early Lyme disease), both IgM and IgG procedures should be performed (MMWR, 1995). Specific IgG and/or IgM are found in only 40-60% of untreated cases EM, particularly in patients with signs haematogenous spread (EUCALB, 2008). In most patients with an active Lyme disease, the level of the antibodies IgM decreases after about 4 months. The antibodies IgG start to emerge in a serum in the 4th week since the infection. In the early disseminated stage or the acute neuroborreliosis, the IgM/IgG seropositiveness increases 70-90%. In this period, the immunological response can be manifested in relation to few antigens. For the diagnosis

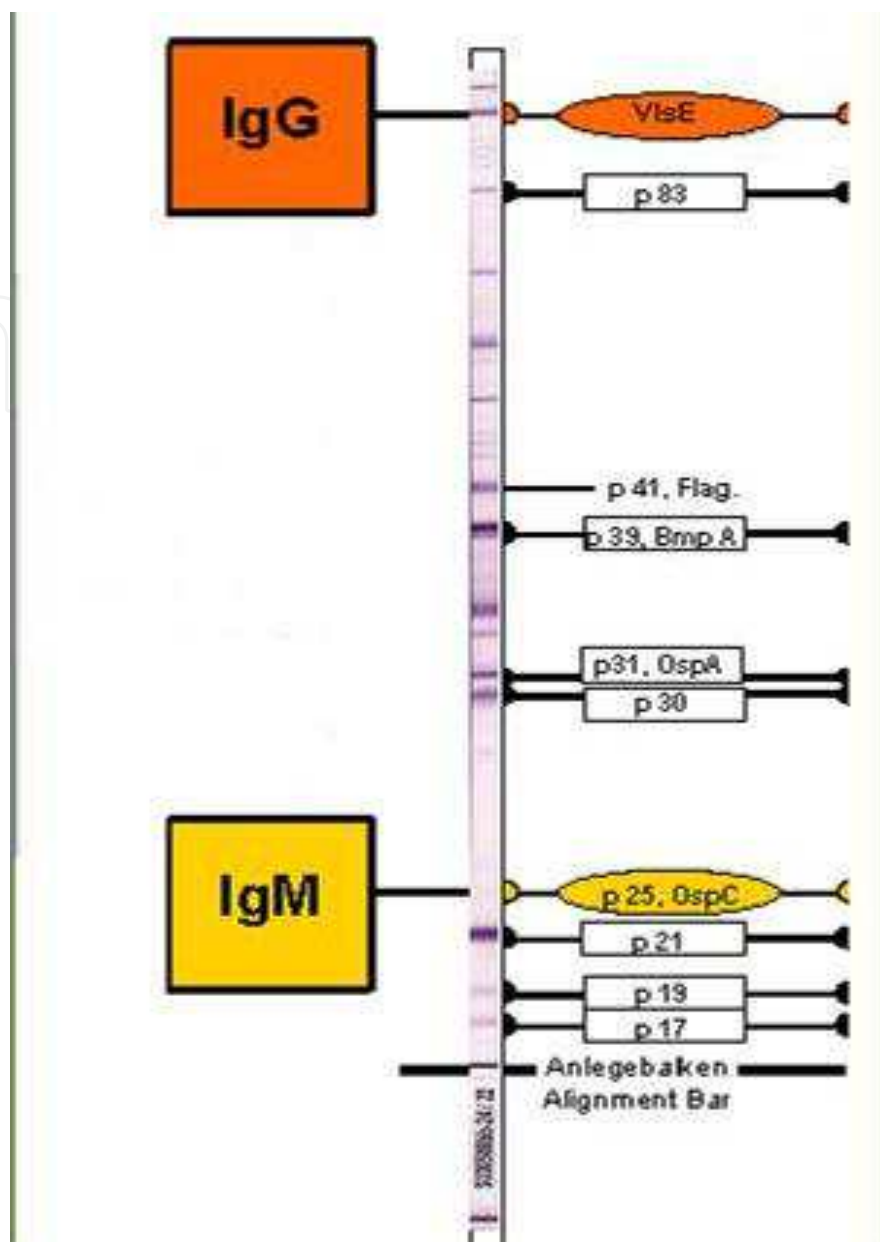

Fig. 1. Western Blot interpretation of IgM/IgG class antibodies against specific antigens plus recombinant VlsE *Borrelia burgdorferi* (according to Euroimmun).

of Lyme arthritis, it is essential to demonstrate the presence of specific IgG antibodies, usually in high levels. A positive IgM test in the absence of IgG antibodies argues against the diagnosis of Lyme arthritis. Follow-up is recommended only in cases with short duration of symptoms. For the diagnosis of acrodermatitis chronica atrophicans (ACA), it is essential to demonstrate high levels of IgG anti-*B. burgdorferi*. A positive IgM test in the absence of IgG antibodies argues against the diagnosis of ACA (EUCALB, 2008). Technical problems that contribute to false-negative or false-positive results include the adoption of inadequate cut-off levels, the presence of cross-reacting antibodies, false positive reactions caused by some autoimmune diseases and inappropriate interpretation criteria for Western blots (Stanek, 2011). Results are considered positive only if the ELISA/IFA and the immunoblot are both positive. CDC does not recommended skipping the first test and just

doing the Western blot. Doing so will increase the frequency of false positive results and may lead to misdiagnosis and improper treatment (CDC, 2011). According to the directives, which are mandatory in Europe, the serological tests determining the level of antibodies IgM/IgG anti-*Borrelia burgdorferi* should not be used in the assessment of the effectiveness of the therapy. The effectiveness of the antibiotic therapy should be assessed only on the basis of the dynamics of the clinical picture (EUCALB, 2008; Flisiak & Pancewicz, 2011). It has not been defined so far that there is a parameter, which marking would reliably determine the effectiveness of the elimination of the pathogen. It has been suggested that, the decrease of the titre of the antibodies for C6 protein can be interpreted as an indicator of the effectiveness of the therapy (Aberer, 2007). The probability that a patient with a positive serological test actually has Lyme borreliosis and the probability that a patient with a negative test does not have the disease depends on the performance characteristics of a given assay (sensitivity and specificity) and also on the prevalence of the disease in the population (Stanek, 2011). Both diagnostic tests (ELISA/IFA and Wb) complement each other mutually. Serological diagnosis is always a balance between sensitivity and specificity of the assays. A high level of specificity is always more important than a high level of sensitivity (EUCALB, 2008). The enzyme immunoassay tests are characterized by high sensitivity and relatively low specificity, whereas the Wb test is characterized by high specificity and low sensitivity (Flisiak & Pancewicz, 2011). A minimum standard of a least 90% specificity for the screening tests (ELISA, IFA) and 95% specificity for the immunoblot should be established in the population where the assay is to be used (EUCALB, 2008). The two-step laboratory testing process is designed to eliminate unspecific falsely positive results which occur in a various frequency during the diagnosis with the use of one test and it allows on an explicit assessment with the interpretation of the limit results. The PCR methods are not used in a routine diagnosis of Lyme disease on account of lack of gained standards, although there are a number of researches done in this matter by many research establishments. The detection of bacteria's DNA made by the PCR method can be interpreted in two ways: it can confirm the presence of a living bacteria in an organism or it can signify on the presence of DNA coming from bacteria killed with antibiotics. The PCR method does not allow on a differentiation of DNA between living and dead being, or free DNA coming from the disintegration of the bacteria cell (Wodecka, 2006b).

### **3. The immunological response against the infection of *B. burgdorferi* in the aspect of clinical symptoms**

The dissemination of the spirochetes into further tissues and organs occurs in a short period of time since the transmission of the infection through blood and lymphatic vessels and it is possible that through peripheral nerves as well (Sigal, 1997). The innate defense mechanisms are initiated as the first in the process of the immunological response of an organism against infection, in which as well as phagocytes as complement system, lysozyme and interferon take part. All disorders of the unspecific mechanisms in the early stage of the infection can prevent from an effective elimination of the pathogen in further stages of the immunological response, and consequently lead to the development of a chronic state of the illness (Bykowski et al., 2008; Siegel, et al., 2010). The diagnosis of the illness in patients with EM is usually made on the basis of a clinical picture without a confirmation of the serological tests, which results are frequently negative during this period. The erythema migrans usually



exposes in the place of a tick's bite after 1-3 weeks. Typical EM has a form of a spot with a tendency of expanding, a diameter of more than 5 cm and a brightening in the middle. Untypical forms do not demonstrate central brightening. They can be shaped irregularly or have hemorrhagic features. The exposure of EM within the period of time shorter than 2 days after a tick's bite and of a diameter less than 5 cm oppose to the diagnosis. Erythema migrans disappear spontaneously within few days since an inception of the antibiotic therapy however it does not mean that the infection has been eliminated. The untreated lesions can stay even for few months and disappear spontaneously, though the infection still lasts (Flisiak & Pancewicz, 2011; Tokarska-Rodak, et al., 2010a, 2010b). It is essential to implement the serological test when EM takes the untypical form or does not appear and there is a suspicion of the infection with the spirochetes of *B. burgdorferi* (Zajkowska, et al. 2006). The symptoms of the disseminated Lyme disease concern: nervous system, heart, muscles and joints (Aberer, 2007; Depietropaolo, 2005). This stage of the disease appears within a few weeks till more than a year since the infection, while the late stage of Lyme disease can occur even many years after the invasion of *Borrelia* spirochetes into human body. The late stage of Lyme disease is manifested with skin lesions (acrodermatitis chronica atrophicans), chronic neurological symptoms or chronic arthritis. *Borrelia* arthritis can take on a chronic form leading to a permanent joint damage, and it can also be manifested by: chronic and migrating muscle pains, recurring arthritis, a pain caused by an inflammatory reaction within the scope of motor organs and the weakening of skeletal muscles (Singh, & Girschick, 2004a; Wilgat, et al., 2004). The presence of IgG for the broad antigen spectrum is observed in persons with symptoms of late Lyme disease, in 100% of patients (EUCALB, 2008; Wilske, et al., 2007). The examination of cerebrospinal fluid is made in the diagnostics of neuroborreliosis. The presence of antibodies anti-*B. burgdorferi* in the cerebrospinal fluid cannot result from their production in the cerebral space but it can be an effect of the penetration of antibodies from blood through the damaged barrier blood-brain (EUCALB, 2008). The decision concerning the diagnosis and treatment of Lyme disease is based on the clinical picture with the results of serological tests taken into account. Lyme disease should not be considered in case of the positive results of the tests and without the presence of clinical symptoms of the disease. Although, it is possible that there is a certain percentage of people in a healthy population, in whom the seropositiveness changing along with the age is observed in comparison with *B. burgdorferi* connected with outdoor activities (Bacon, et al., 2003; Wilske, et al., 2007).

#### **4. The immunological response against *B. burgdorferi* infection in the aspect of the diversity of genospecies**

There are two risk factors of acquiring infection *Borrelia* in a relation to existence on the area where the ticks are present. The first concerns the estimation of spreading *B. burgdorferi sensu lato* in ticks *Ixodes ricinus* which is the main vector of pathogen in Europe. The second factor concerns the determination of diversity of gene-species on a particular area. The risk of human infection *B. burgdorferi* s.l increases along with the number of ticks being infected on a particular area. It depends from the multiple of stabs during the haematophagy season of ticks and it becomes bigger when the time of infected ticks present on a human skin is longer (Oldak, et al., 2009; Wodecka, 2006a). The molecular analysis has shown that isolates of *Borrelia burgdorferi* are genetically and phenotypically diversified, hence the group of

species closely related of genus *Borrelia* were defined as *Borrelia burgdorferi* sensu lato. The complex of *Borrelia burgdorferi* sensu lato encompasses at least 12 species: *B. burgdorferi* sensu stricto, *B. garinii*, *B. afzelii*, *B. spielmani*, *B. valaisiana*, *B. lusitaniae*, *B. japonica*, *B. andersonii*, *B. tunukii*, *B. turdae*, *B. bissetii* and *B. sinica* (Aguero-Rosenfeld et al., 2005; Ruderko, et al., 2009; Sicklinger, et al., 2003; Wodecka, 2006a). According to some sources, there are also *B. californiensis* sp. nov. in this group (Siegel, et al., 2008). *B. afzelii*, *B. garinii*, *B. burgdorferi* sensu stricto and occasionally *B. spielmani*, *B. valaisiana*, *B. lusitaniae* are responsible for causing Lyme disease in Europe whereas in South America only *B. burgdorferi* sensu stricto (Siegel, et al., 2008; Stanek G, 2011; Wilske, et al., 2007). Even though Lyme disease is most generally caused in Europe by the above mentioned three genospecies *Borrelia*, it cannot be excluded that there are other genospecies causing the symptoms of the disease. DNA of *B. valaisiana* was detected in the cerebrospinal fluid of a patient with chronic neuroborreliosis in Greece and in a patient with erythema migrans. *B. lusitaniae* was isolated from a patient with suspected Lyme disease in Portugal (Derdáková & Lenčáková, 2005). Direct relation of skin changes of erythema migrans (EM) type with an infection of *B. spielmani* was revealed in some of the European countries (Netherlands, Germany, Hungary, Slovenia). Thus, the relation of these gene-species with Lyme disease has been proven (Maraspin, 2006; Wilske, et al., 2007). The genetic changeability of *Borrelia* has an influence as well as on the spirochetes' pathogenicity as on the clinical manifestations of the disease. Consequently, the heterogeneity of microorganisms causing Lyme disease in Europe should be taken into consideration in the serological and microbiological diagnostics (Derdáková & Lenčáková, 2005; Richter et al., 2004; Wang et al., 1999; Wilske, et al., 2007). It has been proven that *Borrelia afzelii* is responsible for skin lesions of type acrodermatitis chronica atropicans (ACA) and the presence of borrelia lymphocytoma, whereas *B. garinii* has been isolated more frequently from the cerebrospinal fluid and thus its relation with neuroborreliosis is emphasized. *B. burgdorferi* s.s. is responsible for lesions type arthritis. As well as the late skin lesions as neuroborreliosis are more often detected in Europe whereas Lyme arthritis is more often diagnosed in the USA (Derdáková & Lenčáková, 2005, Wilske, et al., 2003, 2007). All three genospecies *B. burgdorferi* s.s., *Borrelia afzelii* and *Borrelia garinii* can participate in the development of erythema migrans. However, there are differences present in the clinical manifestation of EM caused by those genospecies (Maraspin, 2006; Wodecka, 2006a). According to the serological diagnostics, it is essential to notice whether antibodies IgM/IgG, which are produced in the autoimmune response against the infection caused by other genospecies than those three known as pathogenic in Europe, can be detected by diagnostic tests used in a standard diagnostics of Lyme disease. The problem, among many other things, concerns infections caused only by *B. spielmani*. The results showing that there is a possibility of the infection caused by few genospecies *B. burgdorferi* s.l. has been obtained in the analysis of the presence of antibodies for antigen proteins OspC and p18 of four genospecies *B. burgdorferi* s.s., *B. afzelii*, *B. garinii* and *B. spielmani* in patients with symptoms of Lyme arthritis from Eastern Poland (Tokarska-Rodak, et al., 2010c). The identification of antibodies anti- OspC *B. spielmani* seems to be extremely important considering previous stage of immunological answer when only antibodies IgM anti-OspC are frequently present without antibodies of IgG class. In the case of infection with only one gene-species, the identification of antibodies IgM anti-OspC can be the only chance in the early identification of the infection with the lack of skin symptoms

as EM. Diagnostic tests used routinely in the Lyme disease diagnosis in Europe (ELISA, Western blot) usually have antigen extracts of *B. burgdorferi* s.s., *B. afzelii*, *B. garinii* or electrophoretically separated antigen extracts of *Borrelia afzelii* enriched with recombinant VlsE antigen. According to researchers, the antigens *B. spielmani* – gene-species, which researchers mentioned as the fourth next to *B. burgdorferi* s.s., *B. afzelii*, *B. garinii*, should be additionally used in the tests and be considered in the diagnosis of Lyme disease within Europe (Derdáková & Lenčáková, 2005; Maraspin, 2006; Tokarska-Rodak, et al., 2010c).

#### 4.1 The antigen proteins *B. burgdorferi* diagnostically significant

In the clinical practice the evaluation of the active stage of infection is primarily based on the clinical symptomatology, routine enzyme immunoassays, and confirmatory tests such as Western Blot (CDC, 2011; Štefančíková, et al., 2005; Tokarska-Rodak, et al., 2010a). The identification of the antibodies IgM and IgG directed against specific antigenic proteins *B. burgdorferi* constitutes the basis of the serological diagnostics of Lyme disease. It becomes essential in Europe to use tests with appropriately selected antigenic panel considering the heterogeneity of the proteins *Borrelia burgdorferi* (Štefančíková, et al., 2005). The evolution of a production of the antibodies directed against various antigens *B. burgdorferi* is observed along with the development of the disease process after the transmission of the spirochetes into human body. In the early stage of the infection (2 to 4 weeks) the immunological system detects only few antigens *Borrelia* as p41 (flagellin) and proteins Osp and produces the antibodies IgM against them. OspC is an immunogenic lipoprotein and main virulent factor of the infection in people (particularly genotypes OspC A, B, I, K). OspC poorly succumbs to an expression in a tick's bowels and in a cultivation, however it undergoes intensively only after the transmission of a spirochete into a mammal organism. OspC and OspA are the most important proteins of the outer membrane in the cell of *B. burgdorferi*. OspC is characterized by large polymorphism and a substantial reactivity in comparison with OspA. Both antigens are connected with genetic and antigen heterogeneity among various species. The classification is made on the basis of various genotypes or serotypes. There have been 8 different serotypes OspA and 16 serotypes OspC (*B. burgdorferi* s.s 6 serotypes, *B. afzelii* 4 serotypes, *B. garinii* 6 serotypes) registered in Europe (Aberer, 2007; Wodecka, 2006a). The surface proteins of a spirochete affect significant stages of the immunological response: OspA inhibits the spirochetes' phagocytosis and an oxygen explosion in neutrophils especially at the low concentration of a complement, which substantially simplifies the survival and the dissemination of bacteria. The spirochetes can bind with the receptor cells molecules of a host and the extracellular matrix as integrins, glycoproteins, and proteoglycans (Hartiala, et al., 2008). The antibodies IgG anti-*B. burgdorferi* appears after several weeks since the bite, and their level can remain increased and continue even after the resolution of the clinical symptoms. As far as the infection develops, the immunologic response extends on the increasing number of antigen proteins –p83, p58, p53, p43, p39, BBK32 (p35), p31, p30 (OspA), p25 (OspC), p21, p19, DbpA (p17). The recombinant antigens OspC, p100, VlsE, DbpA (p17), BBK32p66, peptides C10 and C6 are used in order to improve the diagnostics of Lyme disease and for a better prediction of the duration of the infection (Aberer, 2007; Agüero-Rosenfeld et al., 2005; Tokarska-Rodak, et al., 2008, 2010a; Wilske, et al., 2007). The selected antigens such as p83/100, BmpA (p39) or antigens of high specificity but



common for many microorganisms (e.g. the protein of flagellum- flagellin) are introduced. Flagellin (p41) is one of the most immunogenic protein which occurs in the cell of *B. burgdorferi* and causes very strong and early humoral response. Epitopes, which are characteristic for *B. burgdorferi*, only occur between 129 and 251 aminoacid. The protein which comes from the initial and final part of the chain shows a high degree of the homology with the sequence of flagellin's aminoacids *Bacillus subtilis* (65%) and *Salmonella Typhimurium* (56%). The use of the parts only specific for *B. burgdorferi* in diagnostic tests has an influence on the decrease of the percentage of results falsely positive, especially for IgM (Aguero-Rosenfeld, et al., 2005). Other sensitive and specific antigen which may be used in the serological confirmation of the infection is DbpA (p17). Its presence was confirmed in 93% of patients with Lyme arthritis and in 100% of patients with neuroborreliosis (Aberer, 2007). As indicated by the diagnostics of infections caused by *B. burgdorferi* s. l., the essential antigens are highly immunogenic proteins developing in vivo after the spirochetes' transmission into human body. The antigens VlsE, BBA 36 (22kDa), BBO 323 (42 kDa), Crasp 3 (21 kDa), pG (22 kDa) show the expression in vivo and contain highly immunogenic epitopes common for *B. burgdorferi* sensu lato, which are an important determinant for an advanced stages of Lyme disease in the serology of IgG (Bykowski, et al., 2007; Hofmann, et al., 2006; Tokarska-Rodak, et al., 2010a, Wilske, et al., 2007, Zajkowska et al., 2006b). The researchers believe VlsE protein is the most sensitive recombinated *B. burgdorferi* s.l. antigen used in the diagnostics. It is possible to detect IgM/IgG anty-VlsE in all pathogenic *Borrelia burgdorferi* sensu lato genospecies and the risk of false positive results is ten times lower in comparison to other *Borrelia* antigens (Chmielewska-Badora et al., 2006, Liang et al., 2000, Wilske, et al., 2007). In spite of an advanced stage of Lyme disease in some patients, there can be the continuity of the antibodies IgM in relation to the outer superficial protein OspC and VlsE (Hofmann, 2006, Tokarska-Rodak, 2010a). As far as antigen VlsE currently occurs in mostly used serological test ELISA and Western blot, the other antigens are not included into routine diagnostics. There are highly immunogenic proteins CRASPs (complement regulator-acquiring surface proteins) found beside antigen VlsE during the infection of *B. burgdorferi* e.g. CRASP-3, proteins belonging to Erp family (pG), and lots of membrane proteins (immunogenic membrane-associated proteins) among which there is BBO323 (Nowak, et al., 2006; Singh & Girschick, 2004a). The researches confirm the significance of the antigens in vivo in the immunological response against the infection *B. burgdorferi*. The researches conducted by Hofmann and his associates shown that antigens BBA36, BBO323, Crasp3, pG are characteristic for the late infections of *Borrelia*. It has been confirmed that there are the antibodies IgG for BBO323 (90%), BBA36 (67%), p83 (71%) in patients with Lyme arthritis but very seldom antibodies for Crasp3 (38%) and pG (33%) (Hofmann, et al., 2006). The presence of the antibodies IgG anty-VlsE, Crasp3, BBO323, BBA36 has been confirmed with various frequency in patients bitten many times by ticks and with clinical manifestation of Lyme arthritis (Tokarska-Rodak, et al., 2008, 2010a). The presence of antibodies IgG for VlsE and BBO323 have also been confirmed in persons being suspected of the disease, who had erythema migrans (Zajkowska, et al., 2006a, 2006b). It has been assumed that, the routine use of a broaden spectrum of the antigens in vivo (beside VlsE) in Western blot tests can contribute to the designation of the severity and dynamics of the immunological response against the used antigens, what will provide more possibilities in the assessment of the immune reactions in relation to a clinical state of a patient.

## 5. The immunological factors essential in the response of a hosts' organism against the infection of *B. burgdorferi*

In the light of the current knowledge, some diseases and infections are started to be considered in the aspect of probable disfunctions in the control of functioning of the elements of immunological system, including complement system. It allows to look from a different perspective on many disease entities, which are caused by infections of particular pathogenic microorganisms (Klaska, & Nowak, 2007).

### 5.1 The complement system

The dissemination of spirochetes *Borrelia* in the human organism and the development of the infection is a complex, omnidirectional process which occurs owing to many adjustments and mechanisms allowing bacteria to survive. It seems to be essential that *B. burgdorferi* is able to avoid destructive effect of the congenital defence mechanisms. The complement system participates in the elimination of *B. Burgdorferi*, and its activation on the surface of the pathogen leads to the cytotoxic damage of bacteria (Bykowski, et al., 2007). The disactivation of activation cascades of the complement allows *Borrelia* to survive and also determines a competent reservoir for particular genospecies of bacteria (Siegel, et al., 2010). There are also other microorganisms apart from *Borrelia burgdorferi*, like: *Echinococcus granulosus*, *Neisseria meningitidis*, *Neisseria gonorrhoeae*, *Streptococcus pyogenes*, *Streptococcus pneumoniae*, *Yersinia enterocolitica*, *Candida albicans* and human immunodeficiency viruses which have developed mechanisms allowing to overcome the destructive process of the complement system. The acquisition of regulatory molecules of a host allows to avoid an adverse effect of the complement (Klaska, & Nowak, 2007). The microorganisms bind the human fluid phase complement regulators factor H or FHL-1 and some also bind the classical pathway regulator C4Bp directly to the surface (Krajczyk, et al., 2001). Precise analysis *in vitro* within many isolates of three pathogenic genospecies *Borrelia burgdorferi* s.l. shown that all isolates of the same genospecies have similar sensitivity on the complement's effect, however there are significant differences among genospecies. The isolates of *B. afzelii* are particularly resistant to the complement's effect, the majority of *B. burgdorferi* s.s. isolates are on average sensitive, whereas *B. garinii* are fundamentally sensitive on the effect of the complement system (Suchonen, et al., 2002). It is well known that *B. burgdorferi* s.s B31, which come from North America, are less sensitive on the complement's effect than those which come from Europe. The difference comes from a various capacity to bind component C9, which as a result leads to the reduction of the living functions of the spirochetes, and morphological changes and the fragmentation of a bacteria cell (Krajczyk, et al., 2001). Proteins CRASPs (Complement Regulator - Acquiring Surface Proteins) are responsible for the ability to deactivate the complement in the case of *Borrelia burgdorferi* s.l., which are able to bind regulatory proteins of an alternative way, and as a result have an influence on the inhibition of the activation cascade of the complement. CRASPs (from CRASP-1 to CRASP-5) are connected with the soluble forms of the two regulatory proteins - factor H and factor H-like protein 1 (FHL-1) and hence the activation of the complement on the surface of bacteria does not occur. A lot of strains of *B. afzelii* and some of *B. burgdorferi* s.s. are capable to control the alternative way of the complement through the absorption of FHL-1 and H molecules. That kind of capability does not have *B. garinii* which are sensitive on the complement's effect (Krajczyk, et al., 2001; Suchonen, et al., 2002; Zajkowska, et al., 2006c). Serum resistance of *B. burgdorferi* B31 is mainly associated with CRASP-1 and mediated by

binding of complement regulator factor H. OspA and OspC do not bind factor H (Hartiala, et al., 2008). Regardless of the way on which the activation of the complement occurs, the development of the membrane - attack complex (MAC) is a key stage. The researches indisputably confirmed the significance of the complement in the bacteriolysis of *Borrelia*. The spirochetes induce oxidative burst and calcium mobilization and are susceptible to phagocytosis dependent on the complement (Suchonen, et al., 2000, 2002; Krajczyk, et al., 2001). The lack of susceptibility to the effect of the mechanisms of innate immunity, end especially the immunity on the destruction with the use of the complement, is determined as the virulent factor of *Borrelia burgdorferi* (Siegel, et al., 2010).

## 5.2 Lyme disease in the aspect of the autoimmunological processes

The researchers name the long duration of the disease as one of the risk factors of the occurrence of *Borreliosis* which is not curable. One cannot exclude the possibility that the long lasting infection of *B. burgdorferi*, next to typical symptoms of Lyme disease, may also induce the autoimmunological changes in a small percent of patients. The autoimmunological processes can contribute to maintain excessive inflammatory response in late Lyme disease and can be responsible for the inflammatory reaction maintenance, even after the elimination of the pathogen (Grygorczuk, 2008, Kisand, 2007; Singh & Girschick, 2004b Wilgat, 2004). In certain conditions of the environmental stress, the spirochetes can undergo reversible transformation from the motile and helical into inactive, spherical cysts. That kind of forms was observed in the cerebro-spinal fluid and tissues of the patients with Lyme disease (Singh & Girschick, 2004b). The metabolically unactive alveolar forms of *Borrelia* (blebs forms) containing lipoproteins OspA, OspB, OspD are named as a source of long-term antigen stimulation, which lasts even during the absence of bacteria able to multiple (Stere, 2003; Śpiewak, 2004). The examination of the patients with early Lyme disease did not reveal direct connection between the presence of antibodies anti-*Borrelia* and antinuclear antibodies (ANA) (Śpiewak, 2004). It is possible that there is a relation between the initial diagnosis of Lyme disease as erythema migrans and the occurrence in the late stage in a small percentage of people, in spite of the used treatment on arthral symptoms with simultaneous presence of the antibodies ANA (Tokarska-Rodak, 2010b). According to Singh, one potential explanation for antibiotic-resistant Lyme disease is the generation of autoimmunity mediated directly or indirectly by the pathogen (Singh, & Girschick, 2004b). Apoptosis plays the most important role in the control and physiological extinguishing of the inflammatory reaction in the infections, including the infection of *B. burgdorferi*. The impairment of apoptosis of lymphocytes and other leukocytes can be connected with the risk of autoimmunization (Grygorczuk, 2008).

## 5.3 Problems in the diagnosis of Lyme disease are connected with the occurrence of other disease entities

There are many disease states which presence should be considered while interpreting the results of the screening tests and the confirmation tests in the direction of Lyme disease. The antibodies present in the serum of people infected with EBV, CMV or *Mycoplasma* can react crosswise with the antigens of *B. burgdorferi* e.g. p41, OspC, BmpA (p39) which direct the diagnostic proceedings in a wrong direction. The antibodies of the cross-reaction for antigens OspC, p39 *B. burgdorferi* were also observed in the samples with serum of patients

with the infection *Treponema pallidum*, *Herpes simplex virus* (HSV) type 2 (Depietropaolo et al., 2005; Strasfeld, et al., 2005). The antigen Epstein Barr VCA-gp125 (Virus Capsid Antigen) together with antigens *B. burgdorferi* were applied in one of the WB tests used in the diagnostics of Lyme disease. Mononucleosis should be excluded in the mode of various diagnosis in the case when there is a reactivity against EBV-gp125 next to reactivity IgM against specific proteins *Borrelia*. It is widely acknowledged that in persons with autoimmune diseases carried with high index of auto-antibodies (hypergammaglobulinemia), it is necessary to consider the possibility of obtaining falsely positive results in Lyme disease serodiagnostics (EUCALB, 2008; Flisiak & Pancewicz, 2011). The denotations of the antibodies anti-*B. burgdorferi* conducted by Hofmann et al in patients with autoimmune diseases revealed a possibility of the occurrence of the cross-reaction and the obtainment of falsely positive results pointing to the existence of Lyme disease in this group of patients (Hofmann, et al., 2006). Multiple sclerosis, lupus erythematosus can give positive results, especially when the test which is used in order to determine the level of IgM anti-*B. burgdorferi* is based on sonicate antigens (EUCALB, 2008). Due to the growing number of people diagnosed in the direction of Lyme disease, the problem concerning the results falsely positive resulting from the cross reactions seems crucial, especially as regards to people whose symptoms of Lyme disease are unspecific and slightly intensified. Thus, in order to decrease its percentage in the largest extent, the available possibilities of diagnostics should be used.

#### **5.4 Post - Treatment Lyme Disease Syndrome (PTLDS)**

About 10-20% of patients with the diagnose of Lyme disease suffers from the clinical symptoms of constant, repeating or persistent capacity from few months to a year after the use of appropriate antibiotic therapy. The symptoms are nonspecific: muscle and joint pains, cognitive defects, increased fatigue, irritability, emotional lability, disturbances in sleep, concentration, and memory (Feder, et al., 2007). In that kind of cases, the clinical and laboratory assessment aims to exclude the possibility of treatment failure or the presence of a new condition unrelated to previous Lyme borreliosis. That kind of state is defined as post-treatment Lyme disease syndrome (PTLDS) if it is characterised by the presence of persistent symptoms syndrome and lasts longer than 6 months since the treatment. PTLDS cannot be defined as “chronic” Lyme disease, and the occurrence of the symptoms mentioned above do not justify the use of antibiotic therapy, which in these cases is useless and potentially harmful for the patient with PTLDS. The use of symptomatic treatment is recommended for the patients with PTLDS (CDC, 2011; Stanek, et al., 2011). The reason of the occurrence of PTLDS is not entirely explained. It has been assumed that lingering symptoms are due to residua damage to the tissues and immune system that occurred during the infection. Similar complications and auto-immune responses are known to occur following other infectious diseases (CDC, 2011; Seidel, et al., 2007).

## **6. Conclusion**

Highly immunogenic proteins produced in vivo after spirochete transmission into the human body are significant antigens for the diagnostics of *B. burgdorferi* s.l. infections. Antigens VlsE, BBA36, BBO323 and Crasp 3 demonstrate in vivo expression and comprise highly immunogenic epitopes, common for *B. burgdorferi* s.l., which are important IgG



serological markers of advanced stages of borreliosis. Thus a serologic test with those antigens involved creates better potential to evaluate immune response with account for clinical status of the patient. The detection of antibodies directed against specific *B. spielmani* antigens suggests that this microorganism may be responsible for triggering borreliosis both as a single etiologic agent and with other *Borrelia* genospecies. The long-lasting persistence of the disease and thus long-term antigenic stimulation can be considered as a factor enabling the initiation of autoimmune reactions. This process can exist in a small percentage of patients with Lyme disease but the possibility of its inception cannot be completely negated.

## 7. References

- Aberer, E. (2007). Lyme borreliosis-an update. *Journal der Deutschen Dermatologischen Gesellschaft*, Vol.5, No.5, (May 2007), pp. 406-413, ISSN 1610-0387
- Aguero-Rosenfeld, M. E.; Wang, G.; Schwarz, I. & Womser G.P. (2005). Diagnosis of Lyme borreliosis. *Clinical Microbiology Reviews*, Vol.18, No.3, (July 2005), pp. 484-509, ISSN 1098-6618
- Bacon, R. M.; Biggerstaff, B. J. & Schriefer, M. E. (2003). Serodiagnosis of Lyme disease by kinetic enzyme-linked immunosorbent assay using recombinant VlsE or peptide antigens of *Borrelia burgdorferi* compared with 2-tiewred testing using whole -cell lysates. *Journal of Infectious Diseases*, Vol.187, No.8, (April 2003), pp. 1187-1199, ISSN 0022-1899
- Bykowski, T.; Woodman, M. E.; Cooley, A. E. & Brisette, C. A. (2008). *Borrelia burgdorferi* complement regulator-acquiring surface proteins (BbCRASPs): Expression patterns during the mammal-tick infection cycle. *International Journal of Medical Microbiology*, Vol.1, No.298, Supl. 1 (September 2008), pp. 249-256, ISSN 1438-4221
- Center for Disease Control and Prevention (April, 2011). Two-step Laboratory Testing Process, In: *Lyme Disease*, 20.07.2011, Available from: <http://www.cdc.gov/lyme/diagnostictreatment/LabTest/TwoStep/>
- Chmielewska-Badora, J. Cisak, E.; Wójcik-Fatla, A.; Zwoliński, J.; Buczek, A. & Dutkiewicz, J. (2006). Correlation of tests for detection of *Borrelia burgdorferi* sensu lato infection in patients with diagnosed borreliosis. *Annals of Agricultural and Environmental Medicine*, Vol.13, No.2, pp. 307-311, ISSN 1232-1966
- Depietropaolo, D. L.; Powers, J. H.; Gill J. M. & Foy A. J. (2005). Diagnosis of Lyme disease. *American Family Physician*, Vol.72, No.2, (July 2005), pp. 297-304, ISSN 0002-838X
- Derdáková, M. & Lenčáková, D. (2005). Association of genetic variability within the *Borrelia burgdorferi* sensu lato with the ecology, epidemiology of Lyme borreliosis in Europe. *Annals of Agricultural and Environmental Medicine*, Vol.12, pp. 165-172, ISSN 1232-1966
- Deutsche Borreliose-Gesellschaft e.V. (December, 2010) Diagnostyka i leczenie boreliozy z Lyme. Wytyczne Niemieckiego Towarzystwa Boreliozy In: *Deutsche Borreliose-Gesellschaft e.V.* 14.09.2011, Available from: <http://www.borreliosegesellschaft.de/Texte/Wytyczne.pdf>
- European Concerted Action on Lyme Borreliosis (March, 2008). Test in use, In: *Diagnosis serology*, 20.07.2011, Available from: [http://meduni09.edis.at/eucalb/cms/index.php?option=com\\_content&task=view&id=38&Itemid=102](http://meduni09.edis.at/eucalb/cms/index.php?option=com_content&task=view&id=38&Itemid=102)



- Feder, H. M.; Johnson, B. J. B.; O'Connell, S.; Shapiro, E. D.; Steere, A. C.; Wormser, G. P.; & the Ad Hoc International Lyme Disease Group. A critical appraisal of "chronic Lyme disease". (2007). *The New England Journal of Medicine*, Vol.357, No.14, (October 2007), pp.1422-1430, ISSN 0028-4793
- Flisiak, S. & Pancewicz, S. (July 2011). Diagnostyka i leczenie boreliozy z Lyme, In: *Zalecenia Polskiego Towarzystwa Epidemiologów i Lekarzy Chorób Zakaźnych*, 19.07.2011, Available from: <http://www.pteilchz.org.pl/standardy.htm>
- Grygorczuk, S.; Panasiuk, A.; Zajkowska, J.; Kondrusik, M.; Chmielewski, T.; Wierzbińska, R.; Pancewicz, S.; Flisiak, R. & Tylewska-Wierzbanowska, S. (2008). Activity of the caspase-3 in the culture of peripheral blood mononuclear cells stimulated with *Borrelia burgdorferi* antigen. *Przegląd Epidemiologiczny*, Vol.62, No.1, (2008), pp. 85-91, ISSN 0033-2100
- Grygorczuk, S.; Zajkowska, J.; Kondrusik, M.; Moniuszko, A.; Pancewicz, S. & Pawlak-Zalewska, W. (2008). Failures of antibiotic treatment in Lyme arthritis. *Przegląd Epidemiologiczny*, Vol.62, No.3, (2008), pp. 581-588, ISSN 0033-2100
- Hartiala, P.; Hytonen, J.; Suhonen, J.; Lepparanta, O.; Tuominen-Gustafsson, H. & Viljanen, M. K., (2008). *Borrelia burgdorferi* inhibits human neutrophil functions. *Microbes and Infection*, Vol.10, No.1, (January 2008), pp. 60-68, ISSN 1286-4579
- Hofmann, H.; Wallich, R.; Lorenz, I. & Bechtel, M. (22 May 2006). Comparison of a new line assay using purified and recombinant antigens with a European lysate blot for serodiagnosis of Lyme borreliosis. In: *International Journal of Medical Microbiology*, (08.08.2011) Available from: [http://www.sciencedirect.com/science?\\_ob=PublicationURL&\\_tokey=%23TOC%2320444%232006%23997039999.8998%23622693%23FLA%23&\\_cdi=20444&\\_pubType=J&view=c&\\_auth=y&\\_acct=C000054081&\\_version=1&\\_urlVersion=0&\\_userid=1647798&md5=bcc5a55f86b9de38d1638add1eaca44a](http://www.sciencedirect.com/science?_ob=PublicationURL&_tokey=%23TOC%2320444%232006%23997039999.8998%23622693%23FLA%23&_cdi=20444&_pubType=J&view=c&_auth=y&_acct=C000054081&_version=1&_urlVersion=0&_userid=1647798&md5=bcc5a55f86b9de38d1638add1eaca44a)
- Kisand, K. E.; Prökk, T. & Kisand, K. V. (2007). Propensity to excessive proinflammatory response in chronic Lyme borreliosis. *Acta Pathologica Microbiologica et Immunologica Scandinavica*, Vol.115, No.2 (February 2007), pp. 134-41, ISSN 1600-0463
- Klaska, I. & Nowak, J. Z. (2007). The role of complement in physiology and pathology. *Postępy Higieny i Medycyny Doświadczalnej*, Vol.61, (2007), pp. 167-177, ISSN 1732-2693
- Krajczy, P.; Skerka, Ch.; Kirschfink, M.; Zipfel, P. F. & Brade, V. (2001). Mechanism of complement resistance of pathogenic *Borrelia burgdorferi* isolates. *International Immunopharmacology*, Vol.1, No.3, (March 2001), pp. 393-401, ISSN 1567-5769
- Liang, F.; Nowling, J. M. & Philipp, M. T. (2000). Cryptic and Expose Invariable Region of VlsE, the Variable Surface Antigen of *Borrelia burgdorferi* s.l. *Journal of Bacteriology*, Vol.182, No.12, (Jun 2000), pp. 3597-3601, ISSN 1098-5530
- Maraspin, V.; Rudzic-Sabljić, E. & Strle, F. (July 2006). Lyme borreliosis and *Borrelia spielmani*, In: *Emerging Infectious Diseases*, 25.07.2011, Available from: <http://www.cdc.gov/ncidod/EID/vol12no07/06-0077.htm>
- MMWR (August 1995). Notice to readers recommendations for test performance and interpretation from the Second National Conference on Serologic Diagnosis of Lyme Disease, In: *Center for Disease Control and Prevention*, 14.09.2011, Available from: [www.cdc.gov/mmwr/preview/mmwrhtml/00038469.htm](http://www.cdc.gov/mmwr/preview/mmwrhtml/00038469.htm)

- Nowak, A. J.; Gilmore, R. D. & Carroll, J. A. (2006). Serologic proteome analysis of *Borrelia burgdorferi* membrane-associated proteins. *Infection and Immunity*, Vol.74, No.7, (July 2006), pp. 3864-3873, ISSN 1098-5522
- Ołdak, E.; Flisiak, I. & Chodyncka, B. (2009). Lyme borreliosis in children. *Przegląd Dermatologiczny* Vol.96, No. 2, (2009), pp. 146-151, ISSN 0033-2526
- Przytuła, L.; Gińdzieńska-Siekiewicz, E. & Sierakowski, S. (2006). Diagnosis and treatment of Lyme arthritis. *Przegląd Epidemiologiczny*, Supl 1, Vol.60, (April 2006), pp. 125-130, PL ISSN 0033-2100
- Richter, D.; Schlee, D.B.; Allgower, R. & Matuschka, F. R. (2004). Relationships of a novel Lyme disease spirochete, *Borrelia spielmani* sp. nov. with its hosts in Central Europe. *Applied Environmental Microbiology*, Vol.70, No.11, (November 2004), pp. 6414-6419, ISSN 1098-5336
- Robertson, J.; Guy, E.; Andrews, N.; Wilske, B.; Anda, P.; Granström, M.; Hauser, U.; Moosmann, Y.; Sambri, V.; Schellekens, J.; Stanek, G. & Gray, J. (2000). A European multicenter study of immunoblotting in serodiagnosis of Lyme Borreliosis. *Journal of Clinical Microbiology*, Vol.38, No.6, (June 2000), pp. 2097-2102, ISSN: 1098-660X
- Ruderko, N.; Golovchenko, M.; Ruzek, D.; Piskunova, N.; Mallátová, N. & Grubhoffer, L. (March 2009). Molecular detection of *Borrelia bissetii* DNA in serum samples from patients in the Czech Republic with suspected borreliosis, In: *FEMS Microbiology Letters* 25.07.2011, Available from:  
<http://www.ncbi.nlm.nih.gov/pubmed/19187198?ordinalpos=4&itool=EntrezSystem2>
- Seidel, M. F.; Belda Domene, A.; Vetter, H. (2007). Differential diagnoses of suspected Lyme borreliosis or post-Lyme-disease syndrome. *European Journal of Clinical Microbiology & Infectious Diseases*, Vol.26, No.9, (June 2007), pp.611-617, ISSN 1435-4373
- Sicklinger, M.; Winecke, R. & Neubert, U. (2003). In vitro susceptibility testing of four antibiotics against *Borrelia burgdorferi*: a comparison of results for the three genospecies *Borrelia afzelii*, *Borrelia garinii* and *Borrelia burgdorferi sensu stricto*. *Journal of Clinical Microbiology*, Vol.41, No.4, (April 2003), pp. 1791-1793, ISSN 1098-660X
- Siegel, C.; Herzberger, P.; Skerka, Ch.; Brade, V.; Fingerle, V.; Schulze-Spechtel, U.; Wilske, B.; Zipfel, P. F.; Wallich, R. & Kraiczy, P. (1 September 2008). Binding of complement regulatory protein factor H enhances serum resistance of *Borrelia spielmani* sp. nov. In: *International Journal of Medical Microbiology*, 09.08.2011, Available from:  
<http://www.sciencedirect.com/science/article/pii/S1438422108000052>
- Siegel, C.; Hallstrom, T.; Skerka, C.; Eberhardt, H.; Uzonyi, B.; Beckhaus, T. & Karas, M. (20 October 2010). Complement factor H-related proteins CFHR2 and CFHR5 represent novel ligands for the infection-associated CRASP proteins of *Borrelia burgdorferi*, In: *PLoS ONE*, 03.08.2011, Available from:  
<http://www.ncbi.nlm.nih.gov/pmc/articles/PMC2958145/?tool=pubmed>
- Sigal, L. H. (1997). Lyme disease: a review of aspects its immunology and immunopathogenesis. *Annual Review of Immunology*, Vol. 15, (April 1997), pp. 63-92, ISSN 0732-0582

- Singh, S. K. & Girschick, H. J. (2004a). Molecular survival strategies of the Lyme disease spirochete *Borrelia burgdorferi*. *The Lancet Infectious Diseases*, Vol.4, No.9 (September 2004), pp. 4575-83, ISSN1473-3099
- Singh, S. K. & Girschick, H. J. (2004b). Lyme borreliosis: from infection to autoimmunity. *Clinical Microbiology and Infection*, Vol.10, No.7, (July 2004), pp. 598-614, ISSN 1469-0691
- Stanek, G.; Fingerle, V.; Hunfeld, K. P.; Jaulhac, B.; Kaiser, R.; Krause, A.; Kristoferitsch, W.; O'Connell, S.; Ornstein, K.; Strle, F. & Gray, J. (2011). Lyme borreliosis: Clinical case definitions for diagnosis and management in Europe. *Clinical Microbiology and Infection*, Vol.17, No.1, (January 2011), pp. 69-79, ISSN 1469-0691
- Štefančíková, A.; Derdáková, M.; Štěpánová, G.; Peťko, B.; Szestáková, E.; Šktardová, I. & Čisláková, L. (2005). Heterogeneity of *Borrelia burgdorferi* sensu lato and their reflection on immune response. *Annals of Agricultural and Environmental Medicine*, Vol.12, (2005), pp. 211-216, ISSN 1232-1966
- Steere, A. C.; Falk, B. & Drobin, E. E. (2003). Binding of outer surface protein A and human lymphocyte function-associated antigen 1 peptides to HLA-DR molecules associated with antibiotic treatment-resistant Lyme arthritis. *Arthritis & Rheumatism*, Vol.48, No.2, (February 2003), pp. 534-40, ISSN 1529-0131
- Strasfeld, L.; Romanzi, L.; Seder, R. H. & Berardi, V. (2005). False-positive serological test results for Lyme disease in a patient with acute Herpes Simplex virus type 2 infection. *Clinical Infectious Diseases*, Vol.41, No.12, (December 2005), pp. 1826-1827 1537-6591
- Suchonen, J.; Hartiala, K.; Tuominen-Gustafson, H. & Viljanen, M. K. Sublethal concentrations of complement can effectively opsonize *Borrelia burgdorferi*. (2002). *Scandinavian Journal of Immunology*, Vol.56, No.6, (December 2002), pp. 554-560, ISSN 1365-3083
- Suhonen, J.; Hartiala, K.; Tuominen-Gustafsson, H. & Viljanen, M. K. (2000). *Borrelia burgdorferi* - induced oxidative burst, calcium mobilization and phagocytosis of human neutrophils are complement dependent. *The Journal of Infectious Diseases*, Vol.181, No.1, (January 2000), pp. 195-202, ISSN 0022-1899
- Śpiwak, R.; Stojek, N. M. & Chmielewska-Badora, J.(2004). Antinuclear antibodies are not increased in the early phase of *Borrelia* infection. *Annals of Agricultural and Environmental Medicine*, Vol.11, (2004), pp. 145-148, ISSN 1232-1966
- Tokarska-Rodak, M.; Fota-Markowska, H.; Śmiechowicz, F.; Gajownik, B.; Prokop, M.; Modrzewska, R. & Koziol-Montewka, M. (2010a). Antibodies against in vivo *B. burgdorferi* antigens evaluated in patients with Lyme arthritis with reference to treatment. *Advances in Clinical and Experimental Medicine*, Vol.19, No.4, (2010). pp. 489-496, ISSN1230-025X
- Tokarska-Rodak, M.; Niedźwiadek, J.; Fota-Markowska, H.; Śmiechowicz, F.; Gajownik, B.; Modrzewska, R. & Koziol-Montewka, M. (2010b). Antinuclear antibodies in patients with Lyme disease. *New Medicine*, Vol.XIV, No.4, (2010), pp. 152-155, ISSN 1427-0994
- Tokarska-Rodak, M.; Fota-Markowska, H.; Koziol-Montewka, M.; Śmiechowicz, F. & Modrzewska, R. (2010c). The detection of specific antibodies against *B. burgdorferi* s.s., *B. afzelii*, *B. garinii* and *B. spielmani* antigens in patients with Lyme disease in the Eastern Poland. *New Medicine*, Vol.XIV, No.3, (2010), pp. 84-87, ISSN 1427-0994

- Tokarska-Rodak, M.; Koziół-Montewka, M.; Fota-Markowska, H.; Bielec, D.; Modrzewska, R. & Pańczuk, A. (2008). Frequency and specificity of the antibodies against *Borrelia burgdorferi* tested by Western blot method in patients with symptoms of arthritis. *Central European Journal of Immunology*, Vol.33, No.4, (2008), pp. 220-223, ISSN 1426-3912
- Tokarska-Rodak, M.; Koziół-Montewka, M.; Pańczuk, A.; Fota-Markowska, H. & Modrzewska, R. (2007). Borelioza z Lyme-problemy diagnostyczne i rehabilitacyjne, In: *Problemy osób niepełnosprawnych*, Turowski Krzysztof, Paluszkiewicz Piotr, Spisacka Stanisława, pp. 33-36, WSZ, ISBN 978-83-923366-7-9, Biała Podlaska
- Wang, G.; Van Dam, A. P. & Dankert, J. (1999). Phenotypic and genetic characterization of a novel *Borrelia burgdorferi* sensu lato isolate from a patient with Lyme borreliosis. *Journal of Clinical Microbiology* Vol.37, No.9, (September 1999), pp. 3025-3028, ISSN 1098-660X
- Wilgat, P.; Pancewicz, S.; Hermanowska-Szpakowicz, T.; Kondrusik, M.; Zajkowska, J.; Grygorczuk, S.; Popko, J. & Zwierz, K. (2004). Activity of lysosomal exoglycosidases in serum of patients with chronic borrelia arthritis. *Przegląd Epidemiologiczny*, Vol.58, No.3, (2004), pp. 451-458, ISSN 0033-2100
- Wilske, B. (2003). Diagnosis of Lyme borreliosis in Europe. *Victor-Borne and Zoonotic Diseases*. Vol.3, No.4 (2003). pp. 215-227, ISSN 1557-7759
- Wilske, B.; Fingerle, V. & Schulte-Spechtel, U. (2007). Microbiological and serological diagnosis of Lyme borreliosis. *FEMS Immunology & Medical Microbiology* Vol.49, No.1, (February 2007), pp. 13-21, ISSN 1574-695X
- Wodecka, B. (2006a). *Borrelia burgdorferi* - charakterystyka ewolucyjna i molekularna, In: *Biologia molekularna patogenów przenoszonych przez kleszcze*, Stokarczyk Bogumiła, pp. 97. Wydawnictwo Lekarskie PZWL, ISBN-10: 83-200-3490-6, Warszawa
- Wodecka, B (2006b). Metody diagnostyczne polecane w boreliozie z Lyme, In: *Biologia molekularna patogenów przenoszonych przez kleszcze*, Stokarczyk Bogumiła, pp. 142 Wydawnictwo Lekarskie PZWL, ISBN-10: 83-200-3490-6, Warszawa
- Zajkowska, J.; Kondrusik, M.; Pancewicz, S.; Grygorczuk, S.; Wierzbińska, R.; Hermanowska-Szpakowicz, T.; Czeczuga, A. & Sienkiewicz, I. (2006a). Western-Blot with VlsE protein and „in vivo” antigens in Lyme borreliosis diagnosis. *Przegląd Epidemiologiczny*, Vol.60, Supl 1, (April 2006), pp.177-185, ISSN 0033-2100
- Zajkowska, J.; Kondrusik, M.; Pancewicz, S.A.; Sienkiewicz, I.; Grygorczuk, S.; Wierzbińska, R. & Hermanowska-Szpakowicz, T. (2006b). Laboratory diagnosis of early Lyme borreliosis-comparison of ELISA, Western blot (EcoLine), and PCR results. *International Journal of Medical Microbiology*, Vol.296, No.S1, (2006), pp. 291-293, ISSN 1438-4221
- Zajkowska, J.; Grygorczuk, S.; Kondrusik, M.; Pancewicz, S. & Hermanowska-Szpakowicz, T. (2006c). New aspects of pathogenesis of Lyme borreliosis. *Przegląd Epidemiologiczny*, Vol.60, Supl 1 (April 2006), pp. 167-170, ISSN 0033-210



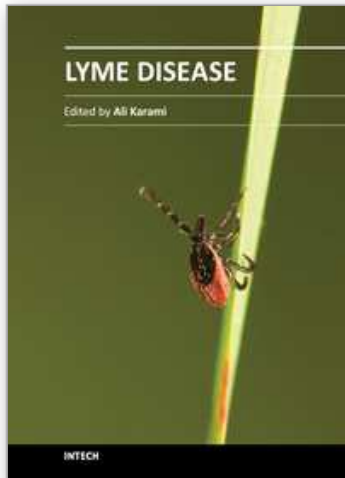

## **Lyme Disease**

Edited by Dr. Ali Karami

ISBN 978-953-51-0057-7

Hard cover, 160 pages

**Publisher** InTech

**Published online** 17, February, 2012

**Published in print edition** February, 2012

Lyme disease, or Lyme borreliosis, is an emerging infectious disease caused by bacteria belonging to the genus *Borrelia*. *Borrelia burgdorferi*, in the strict sense. This book deals mostly with the molecular biology of the Lyme disease agent *Borrelia burgdorferi*. It has been written by experts in the relevant field and is tailored to the need of researchers, advanced students of biology, molecular biology, molecular genetics of microorganism. It will also be of use to infectious disease experts and people in other disciplines needing to know more about Lyme borreliosis. The book contains chapters on the molecular biology of the Lyme disease agent, zoonotic peculiarities of Bb, advancement in Bb antibody testing, the serology diagnostic schemes in Bb, discovering Lyme disease in ticks and dogs, adaptation to glucosamine starvation in Bb, and porins in the genus *Borrelia*.

### **How to reference**

In order to correctly reference this scholarly work, feel free to copy and paste the following:

Małgorzata Tokarska-Rodak and Maria Koziol-Montewka (2012). The Serology Diagnostic Schemes in *Borrelia burgdorferi* Sensu Lato Infections – Significance in Clinical Practice, Lyme Disease, Dr. Ali Karami (Ed.), ISBN: 978-953-51-0057-7, InTech, Available from: <http://www.intechopen.com/books/lyme-disease/the-serology-diagnostic-schemes-in-borrelia-burgdorferi-sensu-lato-infections-significance-in-clinic>

**INTECH**  
open science | open minds

### **InTech Europe**

University Campus STeP Ri  
Slavka Krautzeka 83/A  
51000 Rijeka, Croatia  
Phone: +385 (51) 770 447  
Fax: +385 (51) 686 166  
[www.intechopen.com](http://www.intechopen.com)

### **InTech China**

Unit 405, Office Block, Hotel Equatorial Shanghai  
No.65, Yan An Road (West), Shanghai, 200040, China  
中国上海市延安西路65号上海国际贵都大饭店办公楼405单元  
Phone: +86-21-62489820  
Fax: +86-21-62489821



© 2012 The Author(s). Licensee IntechOpen. This is an open access article distributed under the terms of the [Creative Commons Attribution 3.0 License](#), which permits unrestricted use, distribution, and reproduction in any medium, provided the original work is properly cited.

IntechOpen

IntechOpen