

# We are IntechOpen, the world's leading publisher of Open Access books Built by scientists, for scientists

**4,800**

Open access books available

**122,000**

International authors and editors

**135M**

Downloads

Our authors are among the

**154**

Countries delivered to

**TOP 1%**

most cited scientists

**12.2%**

Contributors from top 500 universities



**WEB OF SCIENCE™**

Selection of our books indexed in the Book Citation Index  
in Web of Science™ Core Collection (BKCI)

Interested in publishing with us?  
Contact [book.department@intechopen.com](mailto:book.department@intechopen.com)

Numbers displayed above are based on latest data collected.

For more information visit [www.intechopen.com](http://www.intechopen.com)



# Power Generation and Distribution System for a More Electric Aircraft - A Review

Ahmed Abdel-Hafez  
Shaqra University  
Kingdom of Saudi Arabia

## 1. Introduction

More-Electric Aircraft (MEA) is the future trend in adopting single power type for driving the non-propulsive aircraft systems; i.e. is the electrical power. The MEA is anticipated to achieve numerous advantages such as optimising the aircraft performance and decreasing the operation and maintenance costs. Moreover, MEA reduces the emissions of air pollutant gases from aircrafts, which can contribute in significantly solving some of the problems of climate change. However, the MEA puts some challenges on the aircraft electrical system, both in the amount of the required power and the processing and management of this power. This chapter introduces the outline for MEA. It investigates possible topologies for the power system of the aircraft. The different electric power generation options are highlighted; while at the same time assessing the generator topologies. It also includes a general review of the power electronic interfacing circuits. Also, the key design requirements for an interfacing circuit are addressed. Finally, a glance at protection facilities for the aircraft power system is given.

## 2. More electric aircraft

Recently, the aircraft industry has achieved a tremendous progress both in civil and military sectors (Abdelhafez & Forsyth, 2008,2009; Cronin, 1990; Moir & Seabridge, 2001). For example some current commercial aircraft operate at weights of over 300 000 kg and have the ability to fly up to 16 000 km in non-stop journey at speed of 1000 km/h (Abdelhafez & Forsyth, 2009).

The non-propulsive aircraft systems are typically driven by a combination of different secondary power drives/subsystems such as hydraulic, pneumatic, electrical and mechanical (Abdelhafez & Forsyth, 2008,2009; Jones, 1999; Moir, 1999; Moir & Seabridge, 2001; Quigley, 1993). These powers subsystems are all sourced from the aircraft main engine by different methods. For example, mechanical power is extracted from the engine by a driven shaft and distributed to a gearbox to drive lubrication pumps, fuel pumps, hydraulic pumps and electrical generators (Abdelhafez & Forsyth, 2009; Jones, 1999; Moir, 1999; Quigley, 1993). Pneumatic power is obtained by bleeding the compressor to drive turbine motors for the engine's starter subsystem, and wing anti-icing and Environmental Control Systems (ECS), while electrical power and hydraulic power subsystems are distributed throughout the aircraft for driving actuation systems such as flight control actuators,

landing gear brakes, utility actuators, avionics, lighting, galleys, commercial loads and weapon systems (Abdelhafez & Forsyth, 2009; Howse, 2003; Jones, 1999; Moir, 1998, 1999; Quigley, 1993).

This combination had always been debated, because these systems had become rather complicated, and their interactions reduce the efficiency of the whole system. For example, a simple leak in pneumatic or hydraulic system jeopardises the journey by grounding the aircraft, and eventually causing inconvenient flight delays. The leak is usually difficult to locate and once located it cannot easily be handled (Abdelhafez & Forsyth, 2009; Cutts, 2002; Hoffman, 1985; Moir, 1998; Pearson, 1998; Rosero, et al, 2007; Weimer, 1993). Furthermore, from manufacturing point of view reducing the cost of ownership, increasing the profit and some anticipated future legislation regarding the climate changes demand radical changes to the entire aircraft, as it is no longer sufficient to optimise the current aircraft sub-systems and components individually to achieve these goals (Abdelhafez & Forsyth, 2009; Andrade, 1992; Cutts, 2002; Clyod, 1997; Emadi & Ehsani, 2000; Hoffman, 1985; Moir, 1998; Pearson, 1998; Ponton, 1998; Rosero, et al, 2007; Weimer, 1993).

The trend is using the electrical power for sourcing and distributing non-propulsive aircraft engine powers. This trend is defined as MEA. The MEA concept is utterly not a new concept, it has been investigated for several decades since W.W. II (Andrade, 1992; Cutts, 2002; Pearson, 1998; Ponton, 1998; Weimer, 1993). However, due to the lack of electric power generation capabilities and prohibitive volume of power conditioning equipments, the focus has been drifted into the conventional power types. Relatively, the recent technology breakthroughs in the field of power electronics systems, fault-tolerant electric machines, electro- hydrostatic actuators, electromechanical actuators, and fault-tolerant electrical power systems have renewed the interest in MEA (Abdelhafez & Forsyth, 2009; Andrade, 1992; Cutts, 2002; Clyod, 1997; Emadi & Ehsani, 2000; Hoffman, 1985; Moir, 1998; Pearson, 1998; Ponton, 1998; Rosero, et al, 2007; Weimer, 1993). A comparison between conventional aircraft subsystems and MEA subsystems is shown in Fig. 1 (Abdelhafez & Forsyth, 2009).

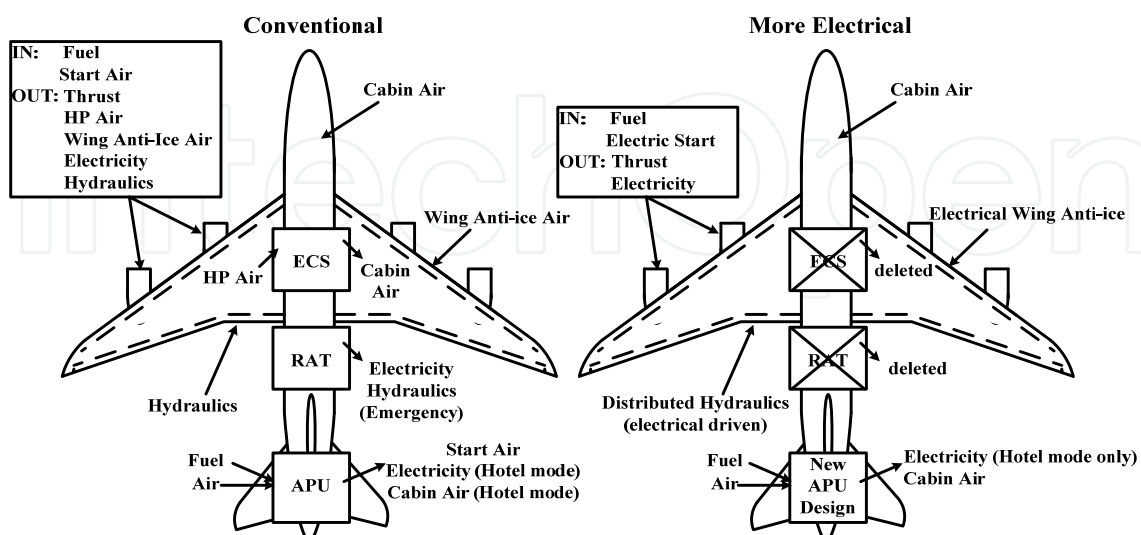

Fig. 1. Comparison between conventional systems aircraft and MEA systems (Abdelhafez & Forsyth, 2009).

The adoption of MEA in the future aircraft both in civil and military sectors will result in tremendous benefits such as:-

1. Removal of hydraulic systems, which are costly, labour-intensive, and susceptible to leakage and contamination problems, improves the aircraft reliability, vulnerability, and reduces complexity, redundancy, weight, installation and running cost (Cutts, 2002; Pearson, 1998; Ponton, 1998; Quigely, 1993; Weimer, 1993).
2. Deployment of electrical starting for the aero-engine through the engine starter/generator scheme eliminates the engine tower shaft and gears, power take-off shaft, accessory gearboxes and reduces engine starting power especially in the cold conditions and aircraft front area (Clyod, 1997; Emadi & Ehsani, 2000; Jones, 1999; Moir & Seabridge, 2001).
3. Utilization of the Advanced Magnetic Bearing (AMB) system, which could be integrated into the internal starter/generator for both the main engine and auxiliary power units, allows for oil-free, gear-free engine area (AbdElhafez & Forsyth, 2009; Andrade & Tenning, 1992a, 1992b; Hoffman et al., 1985; Jones, 1999; Moir & Seabridge, 2001).
4. In MEA, using a fan shaft generator that allowing emergency power extraction under windmill conditions removes the conventional inefficient single-shot ram air turbine, which increases the aircraft's reliability, and survivability under engine-failure conditions (AbdElhafez & Forsyth, 2009; Andrade & Tenning, 1992a, 1992b; Quigley, 1993).
5. Replacement of the engine-bleed system by electric motor-driven pumps reduces the complexity and the installation cost, and improves the efficiency (Jones, 1999).

In general, adopting MEA will revolutionise the aerospace industry completely, and significant improvements in terms of aircraft-empty weight, reconfigurability, fuel consumption, overall cost, maintainability, supportability, and system reliability will be achieved (AbdElhafez & Forsyth, 2009; Clyod, 1997; Cronin, 1990; Emadi & Ehsani, 2000; Hoffman et al., 1985; Moir, 1998, 1999, Weimer, 1993).

On the other hand, the MEA requires more demand on the aircraft electric power system in areas of power generation and handling, reliability, and fault tolerance. These entails innovations in power generation, processing, distribution and management systems (AbdElhafez & Forsyth, 2009; Clyod, 1997; Cronin, 1990; Emadi & Ehsani, 2000; Hoffman et al., 1985; Moir, 1998, 1999).

The proceeding sections briefly discuss a general overview of the electrical power distribution and management, generation and processing systems in MEA.

### **3. Distribution systems**

The power distribution system of the most in-service civil aircrafts is composed of combined of AC and DC topologies. E.g., an AC supply of 115V/400Hz is used to power large loads as such as galleys, while the DC supply of 28V DC is used for avionics, flight control and battery-driven vital services.

Recently there is a trend for using only high voltage DC system for power distribution and management in MEA. A number of factors encouraged this trend (AbdElhafez & Forsyth,

2009; Cross et al., 2002; Hoffman, 1985; Jones, 1999; Glennon, 1998; Maldonado et al., 1996, 1997, 1999; Mallov et al., 2000; Quigely, 1993; Worth, 1990) :

1. Adopting the new generation options as variable frequency,
2. Recent advancements in the areas of interfacing circuits, control techniques and protection systems,
3. The advantages of the high voltage DC distribution system in reducing the weight, the size and the losses, while increasing the levels of the transmitted power.

Some values of the system voltage are presently under research. These values are: 270, 350 and 540V. The exact value, however, is determined by a number of factors such as, the capabilities of DC switchgear, the availability of the components and the risk of corona discharge at high altitude and reduced pressure (Brockschmidt, 1999).

Different topologies were suggested for implementing the distribution system in MEA (Cross et al., 2002; Hoffman, 1985; Glennon, 1998; Maldonado et al., 1996, 1997, 1999; Mallov et al., 2000; Worth, 1990). In the following four main candidates of these topologies are briefly reviewed, as follows :

1. Centralized Electrical Power Distribution System (CEPDS),
2. Semi-Distributed Electrical Power Distribution System (SDEPDS),
3. Advanced Electrical Power Distribution System (AEPDS),
4. Fault-Tolerant Electrical Power Distribution System (FTEPDS).

### 3.1 Centralized Electrical Power Distribution System (CEPDS)

CEPDS is a point-to-point radial power distribution system as shown in Figure 2. It has only one distribution centre. The generators supply this distribution centre. The electrical power is being processed and fed to the different electrical loads. The distribution centre is normally positioned in the avionics bay, Figure 2, where the voltage regulation is also located. In this system, each load is supplied individually from the power distribution centre (Cross et al., 2002; Worth et al., 1990). CEPDS has a number of advantages, such as :

1. The ease of maintenance, since all equipments are located in one place, i.e. avionics bay.
2. Decoupling between loads; thus the disturbance in a load is not transferred to the others.
3. Fault-tolerance, as the main buses are highly protected.

As stated CEPDS may have significant advantages, however it also has a number of disadvantages, such as:

1. CEPDS suffers from the difficulty of upgrading.
2. The faults in the distribution system affect probably all loads and disable the entire system.
3. CEPDS is cumbersome, expensive and unreliable, as each load has to be wired from the avionics bay.
4. Costly and bulky protection system has to be deployed to protect the distribution system.

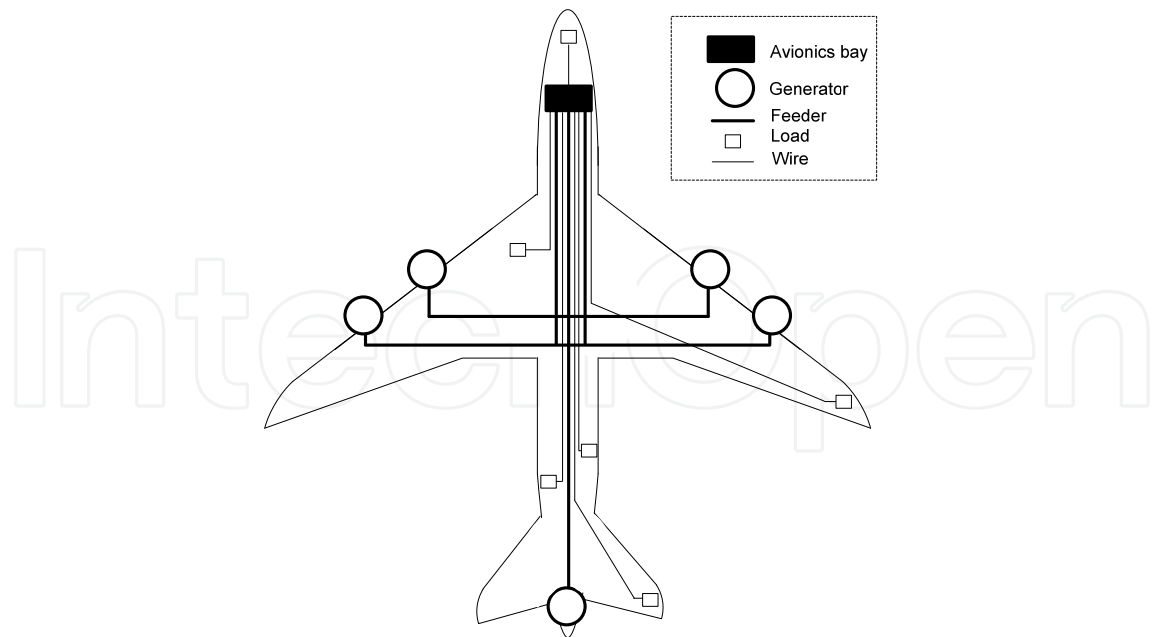

Fig. 2. Centralised Electrical Power Distribution System CEPDS for the MEA (Abdelhafez & Forsyth, 2009).

### 3.2 Semi-Distributed Electrical Power Distribution System (SDEPDS)

SDEPDS was proposed to overcome the problems of CEPDS (Abdelhafez & Forsyth; 2009; Cross et al., 2002; Hoffman, 1985; Glennon, 1998; Maldonado et al., 1996, 1997, 1999; Mallov et al., 2000; Worth, 1990). The SDEPDS as shown in Figure 3 has a large number of Power Distribution Centres (PDCs). These centres are scaled versions of PDCs in CEPDS. The PDCs are distributed around the aircraft in such way to optimise the system volume, weight and reliability. They are located, Figure 3, close to load centres.

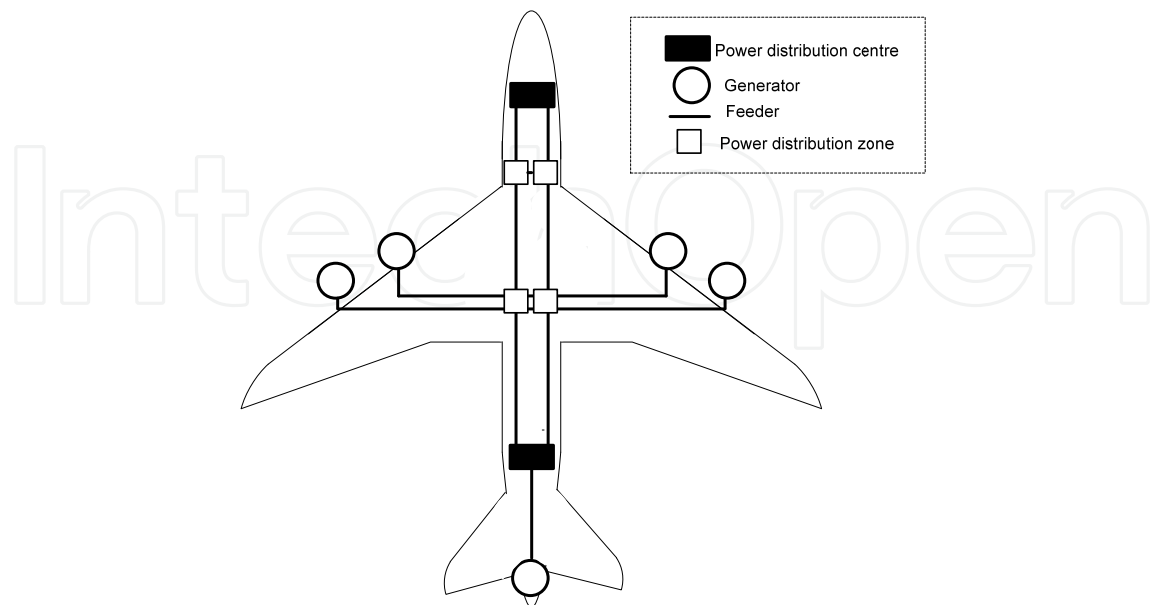

Fig. 3. Semi-Distributed Electrical Power Distribution System SDEPDS for the MEA (Abdelhafez & Forsyth, 2009)

SDEPDS has a number of advantages :

1. Elevated power quality and improved Electromagnetic compatibility, due to the position of the distribution centres near to the loads,
2. High efficiency and cost effective, attributed to the deployment of electrical components with small weight/volume in PDCs,
3. Efficient and stable system operation, due to reduced losses/voltage drops across the distribution network.
4. High level of redundancy in primary power distribution path, due to the strategy of increasing and distributing the PDCs,
5. Simplicity and flexibility of upgrading.

On the other hand, the close coupling between the loads in SDEPDS may reduce the reliability, as faults/ disturbances in a load can propagate to nearby loads. Moreover, extra equipments are required to perform the monitoring and control of the distributed PDCs.

### 3.3 Advanced Electrical Power Distribution System (AEPDS)

AEPDS is a flexible, fault-tolerant system controlled by a redundant microprocessor system. This system is developed to replace the conventionally centralized and semi-distributed systems.

AEPDS as shown in Figure 4, is highly protected. The electrical power from the generators, Auxiliary Power Unit (APU), battery and ground sources is supplied to the primary power distribution, where the Contactor Control Units (CCU) and high power contactors are located. The primary power distribution centre performs a number of tasks: voltage/frequency regulation, damping oscillation and transient and controlling the flow of the reactive power.

The aircraft loads are supplied via the Relay Switching Units (RSU). Each RSU is controlled and monitored by a Remote Terminal (RT) unit. The AEPDS is controlled by either one of the two redundant Electrical load Management Units (ELMU). The ELMU interact and exchange data/control strategies with the RTs through a quad redundant data bus (Mollov et al., 2002; Worth, 1990) .

The AEPDS has improved performance than CEPDS and SDEPDS. This is attributed for the following (Worth, 1990):

1. AEPDS reduces the aircraft life cycle cost, as the system reconfiguration in case of aircraft modification/upgrade can easily be accommodated.
2. AEPDS can detect deviant conditions of current/voltage and provide instantaneous load shut-off.
3. A major reduction in the weight and wiring in the AEPDS is achieved due to the elimination of circuit breaker panels from the flight deck stands.
4. AEPDS is fault-tolerant distribution system.

The AEPDS has the disadvantage of concentrating the distribution and the management of power supplied by the generating units/sources into a single unit; therefore a fault in this unit may interrupt the whole system operation.

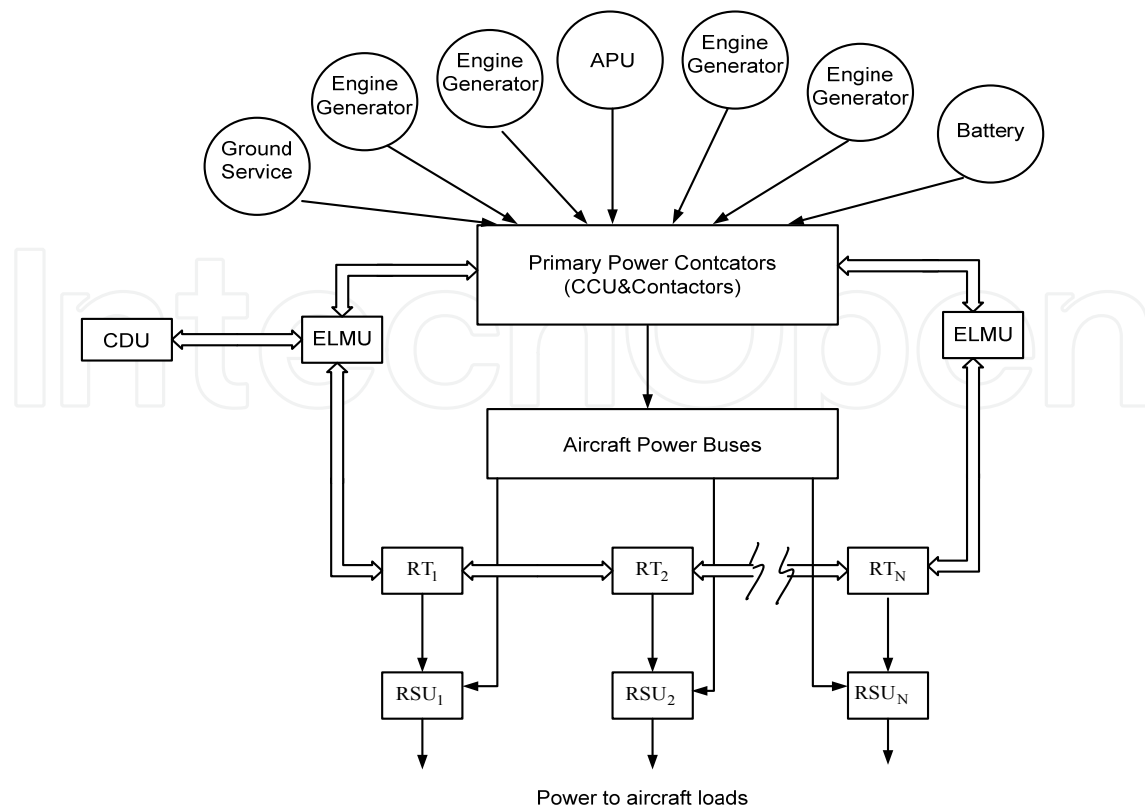

Fig. 4. Advanced Electrical Power Distribution System AEPDS for MEA (Abdelhafez & Forsyth, 2009).

### 3.4 Faulted-Tolerant Electrical Power Distribution System (FTEPDS)

FTEPDS is adequately protected. A typical FTEPDS for a two-engine aircraft is shown in Figure 5. The system is composed of two switch matrices, six multi-purpose converter, six generators and different loads. The source and load switch matrices could be implemented by using mechanical or solid-state switches. However, the latter has the advantages of controllability, fast response and high efficiency (Cross et al., 2002; Hoffman et al., 1985; Glennon, 1998; Maldonado et al., 1996, 1997) over the former.

FTEPDS is a mixed distribution system; the AC power from generators and airport grid are connected to source switch matrix, while 270V DC system is interfaced with the converters. The bi-directional power flow in the generators indicates that system allows integral starter/generator operation, where the generator initially acts as a motor to start the jet engine; then it operates as generator to supply the aircraft electrical system. Also 270V DC system has a bi-directional power flow; this is to charge the batteries and other energy storage units during normal flight conditions. However, during faults and disturbances the DC system injects power to stabilize the aircraft distribution system.

FTEPDS enjoys the following advantages:

1. The ability to start the aircraft engine by generator/starter scheme,
2. High redundancy,
3. Fault-tolerant, the ability of the system to continue functioning even under an engine failure,



However FEEPDS has a serious drawback; a fault in source/load switch matrices may interrupt the operation of the entire system.

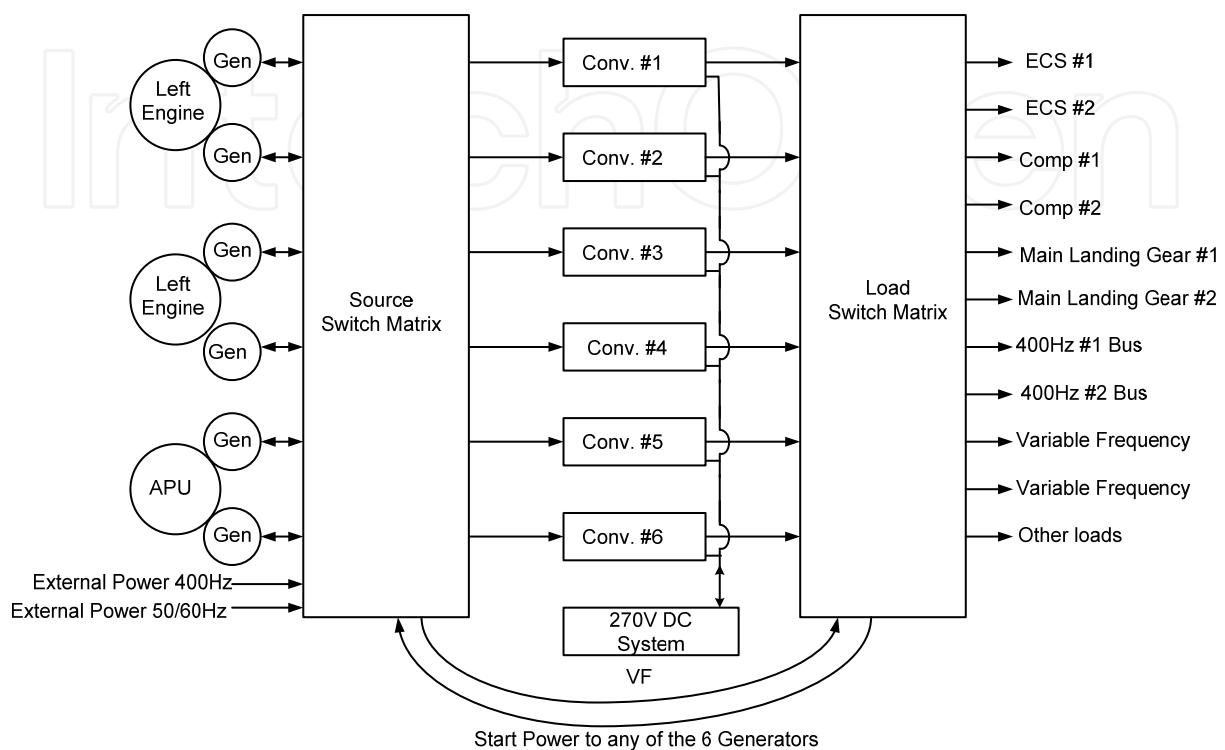

Fig. 5. Fault-tolerant Electrical Power Distribution System FTEPDS for MEA (Abdelhafez & Forsyth, 2009).

#### 4. Electric power generation in MEA

Since its advent, generated electrical power utilization has been rising rapidly. The growth of electrical power generation/application in aircrafts is shown in Figure 6. The quadratic growth is attributed to the increase aircraft system loading such as : galley and In-Flight Entertainment (IFE) systems.

MEA recently is one of the major driving force in electric generation in aircrafts (Abdelhafez & Forsyth, 2009; Andrade, 1992; Bansal et al., 2003, 2005; Howse, 2003; Jones, 1999; Quigely, 1993; Mellor et al., 2005; Moir & Seabridge, 2001; Moir, 1999; Raimondi et al., 2002). Not only are aircraft electrical system power levels growing, but the diversity of the power generation types is increasing as well.

##### 4.1 Schemes of power generation

The various in-service and prospect schemes of electrical power generation are shown in Figure 7 (Abdelhafez & Forsyth, 2009; Cossar, 2004)

Examples of civil/military aircraft and the corresponding generation scheme are given in Table 1.

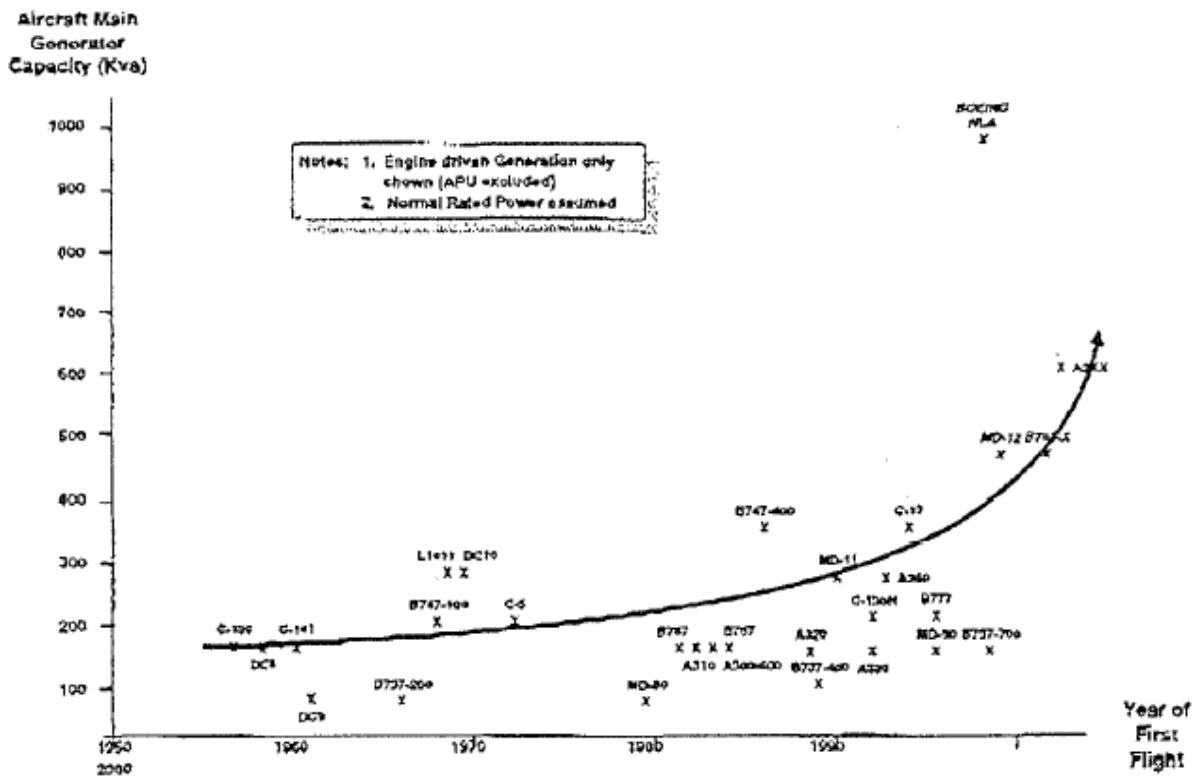

Fig. 6. Growth of generated electrical power in aircraft since the first flight (Abdelhafez & Forsyth, 2009).

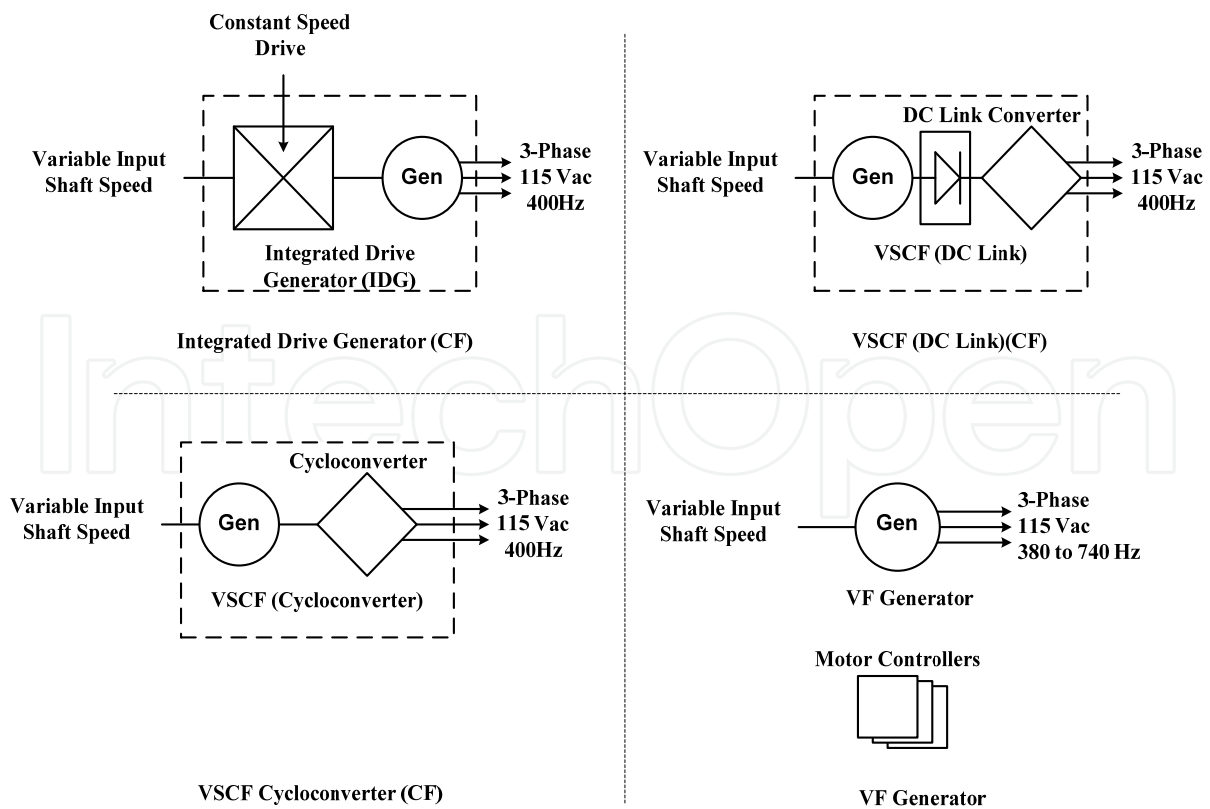

Fig. 7. Aircraft Electrical Power Generation Options (Abdelhafez & Forsyth, 2009).

Generation scheme	Civil		Military	
	Aircraft	Rating (kVA)	Aircraft	Rating (kVA)
CF(IDG)	B777 A340 B373NG MD-12 B747-X B717 B767-400 Do728	2x120 4x90 2x90 4x120 4x120 2x40 2x40 2x40		
VSCF (Cycloconverters)			F-18E/F	2x60/65
VSCF(DC-link)	B77(backup) MD-90	2x20 2x75	C145	2x120
VF	Global Ex Horizon A3xx	4x50 2x20/25 4x150	Boeing JSF	2x50
270VDC			F-22 Raptor X-35A/B/C	2x70 2x50

Table 1. Civil/Military aircraft and electrical power generation techniques (Abdelhafez & Forsyth, 2009).

A brief review of the different generation techniques is given below where the focus is on the merits/demerits of each.

#### 4.1.1 Constant frequency

The constant Frequency (CF), three-phase 115V/400Hz scheme is the most common electric power generation option. This scheme is in-service in most civil aircrafts as shown in Table 1. The CF is alternatively termed Integrated Drive Generator (IDG).

In CF system, the generator is attached to the engine through unreliable and cumbersome mechanical gearbox. This gearbox is essential to ensure that the generator speed is constant irrespective of the engine speed and aircraft status. The frequency  $f$  of the generated power is related to generator speed  $N$  by,

$$f = \frac{PN}{120} \quad (1)$$

where  $f$  is output frequency in cycle/sec(Hz);  $N$  is generator speed in revolution per minutes (rpm) and  $P$  is the number of magnetic poles. Maintaining generator speed  $N$  constant ensures that output frequency remains fixed; however the CF has a number of disadvantages (Abdelhafez & Forsyth, 2009; Cossar, 2004; Howse, 2003; Jones, 1999; Quigely, 1993; Moir, 1999; Raimondi et al., 2002):

1. The interfacing mechanical gear box is unreliable, inefficient and costly, which reduces the overall system efficiency.

2. The system has to be examined for every flight, increasing the operational costs.
3. CF could not allow internal starting for the aero-engine by integral starter/generator scheme.

#### 4.1.2 DC-link system

Variable Speed Constant Frequency (VSCF) DC-link system is now the preferred option for most new military aircraft and some commercial aircraft, Table 1. The generator in this scheme, Figure 7, is attached directly to the engine, thus according to (1) the output frequency will vary with engine speed. The engine speed is subjected to wide variation during the normal course of flight, and so does the frequency; therefore interfacing circuits are required to change the generator output power into usable form.

The output of the generator is supplied to diode rectifiers, which converts the variable frequency AC power into DC form. Then three-phase inverters are used to convert the DC power into three-phase 115V/400Hz AC type. This is the typical form of VSCF DC-link system. However, recently several topologies were reported. These new topologies produce improved performance regarding harmonics, reactive power flow and system stability. Moreover, the range of VSCF DC-link system has been widened due to the recent advancements in field of high power electronic switches. VSCF DC-link option is generally characterised by simplicity and reliability (Abdelhafez & Forsyth, 2009; Hoffman et al., 1985; Ferriera, 1995; Moir, 1999; Quigley, 1993; Olaiya, & Buchan, 1999; Ying shing & Lin, 1995).

#### 4.1.3 Cycloconverters

Variable Speed Constant Frequency (VSCF) Cycloconverters as shown in Figure 2 convert directly the variable frequency AC input power into AC form with fixed frequency and amplitude, three-phase 115V/400Hz (Abdelhafez & Forsyth, 2009; Cloyd, 1997; Cronin, 1990; Emad & Ehasni, 2000; Howse, 2003, Jones, 1999; Moir & Seabridge, 2001). The output frequency is lower than the input frequency; thus, making it possible for the generator to be attached to the engine with a fixed turns ratio gearbox. In the typical form of cycloconverters, three bidirectional switches interface each generator phase with the corresponding supply phase.

The VSCF cycloconverters are more efficient than CF and VSCF DC-link; however they require sophisticated control. The power generation efficiency of the cycloconverters increases as the power factor decrease, which would be beneficial if this technique is applied to motor loads with significant lagging power factors (Abdelhafez & Forsyth, 2009).

#### 4.1.4 Wild frequency

Variable Frequency (VF), commonly known as wild frequency, is the most recent electric power generation contender. In VF approach, the generator is attached directly to the engine shaft. This method is commonly termed embedded generation (Raimondi et al., 2002). Generator direct allocation in the engine shafts de-rates power take-off shaft and the associated gearbox, which reduce their size and weight and increase the reliability. However, a number of implications will arise, in case of embedding one or more electrical machines within the core of the engine:

1. Accommodation of the embedded generators requires revision of the design of the engine components from their current state, which may change the components structure and probably the profile of the airflow through the engine.
2. The heat loss within the generator places a significant burden on the engine oil cooling system, requiring additional or alternative heat exchange.
3. If the generator rotor is only supported through main engine bearings, the small air gap requirement of the generator may lead to obligatory stiffening of the engine structure. The latter being necessary to ensure that rotor and stator do not come into contact under high acceleration
4. Transmitting high levels of electrical power to and from the core of the engine would require significant alterations in the supporting engine core structure relative to the engine pylon (Raimondi et al., 2002).

In VF, variations in engine speed would manifest directly into the output frequency as shown from (1) and Figure 2. The promising features of VF are the small size, weight, volume, and cost as compared with other aircraft electrical power generation options. Also VF offers a very cost-effective source of power for the galley loads, which consumes a lot of on-board power. However VF may pose significant risk at higher power levels, particularly with high power motor loads. Furthermore, the cost of motor controllers required due to the variation in the supply frequency, need to be taken into consideration when assessing VF (Abdelhafez & Forsyth, 2009; Cronin, 2005; Elbuluk & Kankam, 1997; Hoffman, 1999; ; Moir, 1998, Pearson, 1998; Weimer, 1993).

## 4.2 Generator topologies

The anticipated increase in electrical power generation requirements on MEA suggests that high power generators should be attached directly to the engine, mounted on the engine shaft and used for the engine start in Integral Starter/Generator (IS/G) scheme . The harsh operating conditions and the high ambient temperatures push most materials close to or even beyond their limits, requiring more innovations in materials, processes and thermal management systems design.

Consequently, Induction, Switched Reluctance, Synchronous and Permanent Magnet machine types (Hoffman et al., 1985; Mollov et al., 2000; Cross, 2002 ) have been considered for application in MEA due to their robust features.

### 4.2.1 Induction generator

Induction Generators (IGs) are characterized by their robustness, reduced cost and ability to withstand harsh environment. However, the IG requires complex power electronics and is considered unlikely to have the power density of the other machines (Khatounian et al., 2003; Ying & Lin, 1995; Bansal et. al, 2003, 2005).

### 4.2.2 Synchronous generator

The current generator technology employed on most commercial and military aircraft is the three-stage wound field synchronous generator (Hoffman, 1985). This machine is reliable and inherently safe; as the field excitation can be removed, de-energising the machine.

Therefore, the rating of the three-stage synchronous generator has increased over the years reaching to 150KVA (Hoffman, 1985) on the Airbus A380. The synchronous machine has the ability to absorb/generate reactive power, which enhances the stability of the aircraft power system. However, this machine requires external DC excitation, which unfortunately decreases the reliability and the efficiency.

#### 4.2.3 Switched reluctance generator

The Switched Reluctance (SR) machine has a very simple robust structure, and can operate over a wide speed range. The three-phase type has a salient rotor similar to salient pole synchronous machine. The stator consists of three phases; each phase is interfaced with the DC supply through two pairs of anti-parallel switch-diode combination. Thus, the SR machine is inherently fault-tolerant. However the machine has the severe disadvantage of producing high acoustic noise and torque ripples (Mitcham & Cullenm, 2002, 2005; Pollock & Chi-Yao, 1997; Trainer & Cullen, 2005; Skvarenina et al., 1996,1997).

#### 4.2.4 Permanent generator

The Permanent Magnet (PM) generator has a number of favourable characteristics (Abdelhafez & Forsyth, 2009; Argile, 2008; Bianchi, 2003; Jack et al., 1996; Pollock & Chi-Yao, 1997; Mecrow et al., 1996; Mitcham & Cullenm, 2002, 2005):

1. Ease of cooling, as the PM generator theoretically has almost zero rotor losses.
2. High efficiency compared to other machine types.
3. High volumetric and gravimetric power density.
4. High pole number with reduced length of stator end windings.
5. Self excitation at all times.

However, conventional PM machines are claimed to have inferior fault tolerance compared with SR machines (Argile, 2008; Mecrow et al., 1996; White, 1996). Conventional PM generators are intolerant to elevated temperatures. Furthermore, PM generators require power converters with high VA rating to cater for a wide speed range of operation (Abdelhafez & Forsyth, 2009; Bianchi, 2003 ;Jack et al., 1996;Mecrow et al., 1996; Mitcham & Cullenm, 2002, 2005). Therefore, a different implementation is mandatory in PM machine technology if they are to be used in aero-engines.

The fault-tolerant PM machines are one solution and offer high levels of redundancy and fault tolerance (Argile, 2008; Ho et al.,1988; Mitcham & Grum, 1998; Mellor, at al.,2005). These machines are designed with a high number of phases, such that the machine can continue to deliver a satisfactory level of torque/power after a fault in one or more phases. Furthermore, each phase has minimal electrical, magnetic, and thermal impact upon the others (Argile, 2008; Jack et al., 1996; Jones & Drager, 1997;Mecrow et al., 1996; Mitcham & Cullenm, 2002, 2005; White, 1996). This is realised by:

1. The number of magnetic poles in the machine being similar to the stator slot number; each phase winding can be placed in a single slot, which is thermally isolated from the other phases (Abdelhafez, 2008; Adefajo, 2008; Jones & Drager, 1997;Mecrow et al., 1996; Mitcham & Cullenm, 2002).
2. The stator coils being wound around alternate teeth, which provides physical and magnetic isolation between the phases (Abdelhafez, 2008; Jones & Drager, 1997).

3. Each phase being attached to a separate single-phase power converter, which achieves the electrical isolation (AbdElhafez, 2008; Adefajo, 2008; Jack et al., 1996; Jones & Drager, 1997; Mecrow et al., 1996; Mitcham & Cullenm, 2002, 2005).
4. The machine synchronous reactance per phase is typically 1.0 p.u., limiting the short-circuit fault current to no greater than the rated phase current (AbdElhafez, 2008; Jack et al., 1996; Jones & Drager, 1997; Mecrow et al., 1996; Mitcham & Cullenm, 2002, 2005).

### 4.3 Integrated generation

MEA as mentioned, suggests innovative strategies for optimizing the aircraft performance and reducing the installation and operational costs, such as IS/G and emergency power generation schemes.

#### 4.3.1 Integral starter/generator

Commonly, jet engines are externally started by pneumatic power from a ground cart. This reduces the system reliability and increases maintenance and running cost. A move toward internal starting for the engine is adopted in MEA.

The jet engine has two shafts: High Pressure (HP) and Low Pressure (LP) shafts. The main generator is usually attached to the HP shaft. The trend is to use that generator as the prime mover to start the engine. Once the engine is started, the generator returns to its default operation, generator. The prime mover (starter) is powered from the aircraft system, which during this stage is supplied from energy storage devices. ISG scheme has a number of advantages (AbdElhafez & Forsyth, 2009; Ganev, 2006; Elbuluk & Kankam, 1997; Ferreira, 1995; Skvarenina, 1996, 1997) :

1. Improves the aircraft reconfigureability by eliminating the arrangement used previously for ground starting.
2. Allows the adoption of All Electric Aircraft (AEA)
3. Uses AMB system that results in reliable robust and compact engine.
4. Reduces the operational and maintenance cost, which boosts the air traffic industry

Different machine topologies are suggested for IS/G scheme; however the SR and fault-tolerant PM machines are most reliable. These machines do not require external excitation or sophisticated control techniques. Also, they are either inherently or artificially fault-tolerant.

#### 4.3.2 Emergency power generation

The level of the emergency power is expected to grow significantly for future aircrafts, due to rising demands of critical aircraft loads/services. Currently, the emergency power is sourced from generators coupled to a Ram Air Turbine (RAT). This scheme is deployed only under emergency conditions, and suffers from serious drawbacks such as (AbdElhafez et al., 2006a, 2006b, 2008; Adefajo, 2008; Bianchi, 2003) :

1. It is expensive to develop, install and maintain.
2. It is unpopular with the airlines.
3. The integrity of such a 'one-shot' system is always subject to some doubt.

The proposal is to utilize the windmill effect of the aero-engine fan, which is driven from the LP shaft, for emergency power generation. While, the fan is normally rotating, the heath of

the emergency generation system is continuously monitored and backup power will be immediately available following a main generator failure. Also the stored inertial energy of the engine is significant and could be recovered as another source of emergency power (AbdElhafez & Forsyth, 2008, 2009; Ganev, 2006).

Different machine topologies are competing for LP emergency generators. Trade-off studies were conducted to identify the most suitable machine technology. Due to the difficulty of the location, reliability is paramount and it is clear that a brushless machine format is required. The harsh operating environment particularly extremely high ambient temperatures, pushes many common materials, e.g. permanent magnet materials and insulation materials close to or beyond their operating limits. Consequently, cooling or alternative materials and process would be required (AbdElhafez & Forsyth, 2008, 2009; Mitcham & Grum, 1998).

Machine efficiency is another crucial issue, since dissipated heat needs to be absorbed by the engine cooling system. Currently, the generator loss is absorbed by the engine oil system and this is in turn mainly cooled by the fuel entering the engine. This restricts the amount of heat that can be dissipated without introducing an alternative cooling method.

Some key requirements, assisting in the choice of LP generator type are list below (AbdElhafez & Forsyth, 2008, 2009):

1. The machine operates only as a generator, drive torque is not allowed.
2. The machine is subject to a harsh operating environmental conditions (specifically high temperature), with limited access for maintenance.
3. Power must be generated over a very wide speed range (approximately 12:1) with an output voltage compatible with the aircraft DC-distribution system voltage 350 V dc.
4. The machine is fault tolerant, such that it continues to run even if there is a fault on one or two phases without significantly degrading the output power.

Also the operating speed range, weight and volume constraints are important parameters that affect the choice of machine type.

Several brushless machine types seem to have the required ruggedness and hence the capability of operation in such environment. These include: IG, SR and PM machines (AbdElhafez & Forsyth, 2008, 2009; Mitcham & Grum, 1998).

## 5. Interfacing circuits

There are many occasions within the aircraft industry where it is required to convert the electrical power from one level/form to another level/form, resulting in a wide range of Power Electronics Circuits (PECs) such as AC/DC, DC/DC, DC/AC and matrix converters (AbdElhafez & Forsyth, 2009; Chivite-Zabalza, 2004; Cutts, 2002; Lawless & Clark, 1997; Matheson, & Karimi, 2002; Moir & Seabridge, 2001; Singh et. al, 2008). There are general requirements, which PEC should satisfy:

1. PEC should have reduced weight and volumetric dimension.
2. PEC should be fault-tolerant, which implies its ability to continue functioning under abnormal conditions without much loss in its output power or degradation of its performance.



3. PEC should be efficient and have the ability for operation in harsh conditions such as high temperature and low maintenance.
4. PEC should emit minimum levels of harmonic and Electromagnetic Interference (EMC).
5. PEC could be easily upgraded and computerized.

Innovation in the area of power electronics components is required to enable realisation of MEA. Wide-Band Gap (WBG) High-Temperature Electronics (THE) is an example of these developments. The devices manufactured from WBG-THE are capable of operating at both higher temperatures (600 °C) (Reinhardt & Marciniak, 1996) and higher efficiencies compared to Si-based devices (-55 °C to 125 °C). A number of advantages are expected to be realized from employing WBG-THE devices (Abdelhafez et al., 2006, 2008, Howse, 2003; Gong et al., 2003; Lawless & Clark, 1997; Matheson, & Karimi, 2002; Moir & Seabridge, 1998, 2001; Trainer & Cullen, 2005 ):

1. Eliminating/reducing of ECS required for cooling flight control electronics and other critical PECs
2. Reducing the engine control system weight and volumetric dimension
3. Improving the system reliability by using a distributed processing architecture
4. Optimizing the aircraft system and reducing the installation and running cost
5. Improving system fault-tolerance and redundancy

Another main challenge for PECs in the aircraft is passive electrical component size, as the current components are heavy and bulky, especially for the high power level expected in the MEA. However, the on-going research in the design and fabrication of the passive components for MEA gives some optimistic results. For example, some advanced polymer insulation materials such as Eymyd, L-30N, and Upilex S (Abdelhafez & Forsyth, 2009; Cutts, 2002; Lawless & Clark, 1997; Moir & Seabridge, 2001 ) have the ability to operate over a wide temperature range (-269 °C to 300 °C). Also these materials can withstand the environmental conditions such as humidity, ultraviolet radiation, basic solution and solvent at high altitudes (Abdelhafez & Forsyth, 2009; Lawless & Clark, 1997). The ceramic capacitor is a good example, which offers remarkable advantages in volumetric density compared to other capacitor technology (Lawless & Clark, 1997).

	SSCB	Conventional
Mechanism	The breaker consists of bidirectional switches that allow current flow in both directions. The gating signal of the switches are blocked to inhabit the faulty current	Commonly an isolating air gap is developed in the path of the fault current. A upon disconnection, an arc is created. Depending on the arc distinguishing methodology the breaker is termed.
Response time	Very small	Long
Power rating	Small	Medium to high
Volumetric/weight	Compact/small	Bulky/heavy
Cost	Expensive	Cheap
Functionality	Multi-task, they perform current monitoring and status reporting	They should be instructed to be opened

Table 2. Comparison between SSCB and conventional breakers.

## 6. Protection system

The distribution system of aircraft is adequately protected; different types of Circuit Breakers (CBs) are utilized. This includes the conventional and power electronics based. The conventional CBs include air, SF<sub>6</sub>, and oil, while the Solid-State Circuit Breakers (SSCBs) represent the power electronics based breakers (Abdelhafez & Forsyth, 2009; Jones, 1999; Moir & Seabridge, 2001). A comparison between SSCB and a generic conventional CB is given in Table 2 above.

## 7. References

- Abdelhafez, A. (2008). *Active Rectifier Control for Multi-Phase Fault-Tolerant Generators*. PhD dissertation, University of Manchester, UK.
- Abdel-Hafez, A.; Cross, A.; Forsyth, A.; Mitcham, A.; Trainer, D. & Cullen, J. (2006). Fault Tolerant Starter-Generator Converter Optimisation ", Patent Application Rolls-Royce, Ed. UK, 2006.
- Abdel-hafez, A.; Cross, A.; Forsyth, A.; Trainer, D. & Cullen, J. (2006). Single-Phase Active Rectifier Selection for Fault Tolerant Machine, in *3rd IET International Conference on Power Electronics, Machines and Drives, PEMD 2006*, pp. 435-439, April 2006.
- AbdelHafez, A & Forsyth, A. J. (2009) . A Review of More-Electric Aircraft, *Proceedings of The 13rd international conference on Aerospace Science and Aviation Technology conference ,ASAT-13*. Cairo, Egypt, May 26-28, 2009.
- Abdel-Hafez, A.; Todd, R.; Forsyth, A. & Long, S. (2008). Single-Phase Controller Design for a Fault Tolerant Permanent Magnet Generator, in *IEEE Vehicle Power and Propulsion Conference, VPPC 2008*, pp. 250-257, September 2008.
- Adefajo, O.; Barnes, M.; Smith, A.; Long, S.; Trainer, D.; Abdel-hafez, A.; & Forsyth, A. (2008). Voltage Control On An Uninhabited Autonomous Vehicle Electrical Distribution System," in *The 4th IET International Conference on Power Electronics, Machines and Drives, PEMD 2008*, pp. 676-680, April 2-4, 2008.
- Andrade, L. & Tenning, C. (1992). Design of the Boeing 777 Electric System, *IEEE National Aerospace and Electronics Conference*, pp. 1281 - 1290, May 18-22, 1992.
- Andrade, L. & Tenning, C. (1992). Design of Boeing 777 electric system, *IEEE Aerospace and Electronic Systems Magazine*, Vol. 7, (1992) pp. 4-11.
- Argile, R.; Mecrow, B.; Atkinson, D.; Jack, A. & Sangha, P. (2008). reliability analysis of fault tolerant drive topologies, *the Proceeding of The 4th IET International Conference on Power Electronics, Machines and Drives, PEMD 2008*, pp 11-15, April 2-4, 2008.
- Bansal, R.; Bhatti, T. & Kothari, D. (2003). Bibliography on the application of induction generators in nonconventional energy systems," *IEEE Transaction on Energy Conversion*, Vol. 18, (September 2003), pp. 433-439.
- Bansal, R. (2005). Three-phase self-excited induction generators: an overview, *IEEE Transaction on Energy Conversion*, Vol. 20, (2005), pp. 292-299.
- Bianchi, N.; Bolognani, S.; Zigliotto, M. & Zordan, M. (2003). Innovative remedial strategies for inverter faults in IPM synchronous motor drives, *IEEE Transaction on Energy Conversion*, Vol. 18, (June 2003), pp. 306-314.
- Brock, A. & Schmidt, T. (1999). Electrical environments in aerospace applications, in *Proceedings of International Conference Electric Machines and Drives, IEMD '99*, pp. 719-721, May 9-12, 1999.
- Chivite-Zabalza, F.; Forsyth, A. & Trainer, D. (2004). Analysis and practical evaluation of an 18-pulse rectifier for aerospace applications, in *Second International Conference on Power*

- Electronics, Machines and Drives, PEMD 2004, Vol.1, pp. 338-343, March-31 April-2, 2004.*
- Cloyd, J. (1997). A status of the United States Air Force's More Electric Aircraft initiative," in *Proceedings of the 32nd Intersociety Energy Conversion Engineering Conference, IECEC-97, Vol.1, pp. 681-686, July-27 August-1 1997.*
- Cross, M.; Forsyth, A & Mason, G. (2002) . Modelling and simulation strategies for the electric system of large passenger aircraft," in *SAE 2002 conference, pp. 450-459, 2002.*
- Cutts, S. (2002). A collaborative approach to the More Electric Aircraft, in *Proceedings of International Conference on Power Electronics, Machines and Drives,PEMD 2002, pp. 223-228, April 16-18, 2002.*
- Cossar, C.& Sawata, T. (2004). Microprocessor controlled DC power supply for the generator control unit of a future aircraft generator with a wide operating speed range, in *Second International Conference on Power Electronics, Machines and Drives, PEMD 2004, Vol.2, pp. 458-463, March 31, April-2, 2004.*
- Cronin, M. (1990). The all-electric aircraft, *IEE Review, Vol. 36, (September 1990), pp. 309-311.*
- Elbuluk, M.& Kankam, P. (1997). Potential starter/generator technologies for future aerospace applications, *IEEE Aerospace and Electronic Systems Magazine, Vol. 12, (May 1997),pp. 24-31.*
- Emadi, K & Ehsani, M. (2000). Aircraft power systems: technology, state of the art, and future trends, *IEEE Aerospace and Electronic Systems Magazine, Vol. 15, (January 2000), pp. 28-32.*
- Ferreira, C.; Jones, S.; Heglund, W.& Jones, W. (1995). Detailed design of a 30-kW switched reluctance starter/generator system for a gas turbine engine application, *IEEE Transactions on Industry Applications, Vol. 31, (May/June 1995). pp. 553-561.*
- Ganev, E. (2006). High-Reactance Permanent Magnet Machine for High-Performance Power Generation Systems" *SAE Power Systems Conference, pp. 247-253, November, 2006.*
- Glennon, T. (1998). Fault tolerant generating and distribution system architecture," in *IEE Colloquium on All Electric Aircraft, (June 1998), pp. 1-4.*
- Gong, G.; Drofenik, U.& Kolar, J. (2003). 12-pulse rectifier for more electric aircraft applications, in *IEEE International Conference on Industrial Technology, Vol.2, pp. 1096-1101, December 10-12, 2003.*
- Hoffman, A; Hansen, A. Beach, R.; Plencner, R.; Dengler, R.; Jefferies, K. & Frye, R. (1985) Advanced secondary power system for transport aircraft, *NASA Technical Paper 2463, (May 1985) [http://ntrs.nasa.gov/archive/nasa/19850020632\\_1985020632.pdf](http://ntrs.nasa.gov/archive/nasa/19850020632_1985020632.pdf)*
- Hoffman, A.; Hansen, I.; Beach, R.; Plencner, R.;Dengler, R.; Jefferies, K. & Frye, J. (1985) "Advanced secondary power system for transport aircraft," in *IEE Colloquium on All Electric Aircraft, (June 1995), pp. 1-4.*
- Ho, T.; Bayles, R. & Sieger, E. (1988). Aircraft VSCF generator expert system," *IEEE Aerospace and Electronic Systems Magazine, Vol. 3, (April 1988), pp. 6-13.*
- Howse, M. (2003). All electric aircraft, *Power Engineer Journal, Vol. 17, (2003) pp. 35-37.*
- Jack, A.; Mecrow, B. and Haylock, J. (1996). A comparative study of permanent magnet and switched reluctance motors for high-performance fault-tolerant applications, *IEEE Transactions on Industry Applications, Vol. 32, (July/August 1996), pp. 889-895.*
- Jones, R. (1999). The More Electric Aircraft: the past and the future?, in *IEE Colloquium on Electrical Machines and Systems for the More Electric Aircraft,(November 1999), pp. 1-4.*
- Jones, S. & Drager, B. (1997). Sensorless switched reluctance starter/generator performance,*IEEE Industry Applications Magazine, Vol. 3, (1997), pp. 33-38.*
- Khatounian, F.; Monmasson, E.; Berthereau, F.; Delaleau, E.& Louis, J. (2003). Control of a doubly fed induction generator for aircraft application, in *Proceedings of 29th Annual*

- Conference of the IEEE Industrial Electronics Society, IECON '03, Vol.3, (November 2003), pp. 2711-2716.*
- Lawless, W. & Clark, C. (1997). Energy storage at 77 K in multilayer ceramic capacitors, *IEEE Aerospace and Electronic Systems Magazine*, Vol. 12, (August 1997), pp. 32-35.
- Maldonado, M. & Korba, G. (1999). Power management and distribution system for a more-electric aircraft (MADMEL)," *IEEE Aerospace and Electronic Systems Magazine*, Vol. 14, (1999), pp. 3-8.
- Maldonado, M.; Shah, N.; Cleek, K.; Walia, P. & Korba, G. (1996). Power management and distribution system for a more-electric aircraft (MADMEL)-program status," in *Proceedings of the 32nd Intersociety Energy Conversion Engineering Conference, IECEC-97. Vol. 1, pp. 148-153, 1996.*
- Maldonado, M.; Shah, N.; Cleek, K.; Walia, P. & Korba, G. (1997). "Power Management and Distribution System for a More-Electric Aircraft (MADMEL)-program status," in *Proceedings of the 33rd Intersociety Energy Conversion Engineering Conference, IECEC-97. Vol. 1, pp. 274-279. 1997.*
- Matheson, E.; Karimi, K. (2002). Power Quality Specification Development for More Electric Airplane Architectures, in *SAE International Conference*, Vol. 2, pp. 343-347, 2002.
- Mecrow, B.; Jack, A.; Haylock, J. & Coles, J. (1996). Fault-tolerant permanent magnet machine drives, *IEE Electric Power Applications*, Vol. 143, (November 1996), pp. 437-442.
- Mellor, P.; Burrow, S.; Sawata, T. & Holme, M. (2005). A wide-speed-range hybrid variable-reluctance/permanent-magnet generator for future embedded aircraft generation systems, *IEEE Transactions on Industry Applications*, Vol. 41, (March-April 2005), pp. 551-556.
- Mitcham, A. ; Antonopoulos , G. & Cullen, J. (2002). Favourable slot and pole number combinations for fault-tolerant PM machines, in *Proceedings of IEE Electric Power Applications*, Vol. 151, (September 2004), pp. 520-525.
- Mitcham, A. & Grum, N. (1998). An integrated LP shaft generator for the more electric aircraft. in *IEE Colloquium on All Electric Aircraft*, (June 1998), pp. 1-9.
- Mitcham, A. & Cullen, J. (2005). Permanent Magnet Modular Machines: New design Philosophy, in *Electrical Drive Systems for the More Electric Aircraft one-Day Seminar*, pp. 1-8, 2005.
- Mitcham, A. & Cullen, J. (2002). Permanent magnet generator options for the More Electric Aircraft, in *Proceeding of International Conference on Power Electronics, Machines and Drives, PEMD 2002*, pp. 241-245, April 16-18, 2002.
- Moir, I. (1999). .More-electric aircraft-system considerations, in *IEE Colloquium on Electrical Machines and Systems for the More Electric Aircraft*, (1999), pp. 1-9.
- Moir, I. & Seabridge, A. (2001). *Aircraft systems : mechanical, electrical, and avionics subsystems integration*, London press, London, UK
- Moir, I. (1998). .The all-electric aircraft-major challenges," in *IEE Colloquium on All Electric Aircraft*, (June 1998), pp. 1-6.
- Mollov, S.; Forsyth, A. & Bailey, M. (2000). System modelling of advanced electric power distribution architecture for large aircraft," *SAE Transaction* (2000), pp. 904-913.
- Olaiya, M. & Buchan, N. (1999) "High power variable frequency generator for large civil aircraft," in *IEE Colloquium on Electrical Machines and Systems for the More Electric Aircraft*, (November 1999), pp. 1-4.
- Pearson, W. (1998). The more electric/all electric aircraft-a military fast jet perspective, in *IEE Colloquium on All Electric Aircraft* (June 1998), pp. 1-7.
- Ponton, A. & at al (1998). "Rolls-Royce Market Outlook 1998-2017," *Rolls-Royce Publication No TS22388* (1998).

- Pollock C. & Chi-Yao, W. (1997). Acoustic noise cancellation techniques for switched reluctance drives," *IEEE Transactions on Industry Applications*, Vol. 33, (March/April 1997), pp. 477-484.
- Provost, M. (2002). The More Electric Aero-engine: a general overview from an engine manufacturer, in *Proceedings of International Conference on Power Electronics, Machines and Drives, PEMD 2002*, pp. 246-251, April 16-18, 2002.
- Quigley, R. (1993). More Electric Aircraft, in *Proceedings of Eighth Annual Applied Power Electronics Conference and Exposition, APEC '93*, pp. 906-911, March 1993.
- Raimondi, C.; Sawata, T.; Holme, M.; Barton, A.; White, G.; Coles, J.; Mellor, P. & Sidell, N (2002). Aircraft embedded generation systems, in *Proceeding of International Conference on Power Electronics, Machines and Drives, PEMD 2002*, pp. 217-222, April 16-18, 2002.
- Reinhardt, K.& Marciniak, M. (1996). Wide-band gap power electronics for the More Electric Aircraft, in *Proceedings of the 31st Intersociety Energy Conversion Engineering Conference, IECEC 96.*, pp. 127 - 132, August 11-16, 1996.
- Richter, E. & Ferreira, C. (1995). Performance evaluation of a 250 kW switched reluctance starter generator, in *Thirtieth IAS Annual Meeting IEEE Industry Applications Conference, IAS '95.*, Vol.1, pp. 434-440, October 8-12, 1995.
- Rosero, J; Ortega, J.; Aldabas, E. & Romeral, L. (2007) Moving towards a more electric aircraft, *IEEE Aerospace and Electronic Systems Magazine*, Vol. 22, (2007), pp. 3-9.
- Shing, Y.& Lin, C. (1995). A prototype induction generator VSCF system for aircraft, in *International IEEE/IAS Conference on Industrial Automation and Control: Emerging Technologies*, pp. 148-155, May 22-27, 1995.
- Singh, B.; Gairola, S.; Singh, N.; Chandra, A.& Al-Haddad, K. (2008). Multiples AC-DC Converters for Improving Power Quality: A Review, *IEEE Transactions on Power Electronics*, Vol. 23, (January 2008.), pp. 260-281.
- Skvarenina, T.; Pekarek, S.; Wasynczuk, O.; Krause, P.; Thibodeaux, R. & Weimer, J. (1997), Simulation of a switched reluctance, More Electric Aircraft power system using a graphical user interface, in *Proceedings of the 32nd Intersociety Energy Conversion Engineering Conference, IECEC-97, 1997*, Vol.1, pp. 580-584, July-27 August - 1, 1997.
- Skvarenina, T.; Wasynczuk, O.; Krause, P.; Zon, W.; Thibodeaux, R.& Weimer, J. (1996). Simulation and analysis of a switched reluctance generator/More Electric Aircraft power system, in *Proceedings of the 31st Intersociety Energy Conversion Engineering Conference, IECEC 96.*, Vol.1, pp. 143-147, August 11-16, 1996.
- Trainer, D. & Cullen, J. (2005). Active Rectifier for Fault Tolerant Machine Application, Derby, internal memorandum, February 24, 2005.
- White, R. & Miles, M. (1996). Principles of fault tolerance, *the Proceeding of Eighth Annual Applied Power Electronics Conference and Exposition, APEC '96*, Vol.1, pp. 18-25, 1996.
- Weimer, J. (1993). Electrical power technology for the more electric aircraft, in *Proceedings of 12th AIAA/IEEE Digital Avionics Systems Conference, DASC 1993*, pp. 445-450, October 25-28, 1993.
- Welchko, B.; Lipo, T.; Jahns, T. & Schulz, S.(2004). Fault tolerant three-phase AC motor drive topologies: a comparison of features, cost, and limitations, *IEEE Transactions on Power Electronics*, Vol. 19, (July 2004), pp. 1108-1116.
- Worth, F.; Forker, V.; Cronin, M. (1990). Advanced Electrical System (AES)," in *Aerospace and Electronics Conference*, pp. 400 - 403, 1990.



## **Recent Advances in Aircraft Technology**

Edited by Dr. Ramesh Agarwal

ISBN 978-953-51-0150-5

Hard cover, 544 pages

**Publisher** InTech

**Published online** 24, February, 2012

**Published in print edition** February, 2012

The book describes the state of the art and latest advancements in technologies for various areas of aircraft systems. In particular it covers wide variety of topics in aircraft structures and advanced materials, control systems, electrical systems, inspection and maintenance, avionics and radar and some miscellaneous topics such as green aviation. The authors are leading experts in their fields. Both the researchers and the students should find the material useful in their work.

### **How to reference**

In order to correctly reference this scholarly work, feel free to copy and paste the following:

Ahmed Abdel-Hafez (2012). Power Generation and Distribution System for a More Electric Aircraft - A Review, Recent Advances in Aircraft Technology, Dr. Ramesh Agarwal (Ed.), ISBN: 978-953-51-0150-5, InTech, Available from: <http://www.intechopen.com/books/recent-advances-in-aircraft-technology/more-electric-aircraft>

**INTECH**  
open science | open minds

### **InTech Europe**

University Campus STeP Ri  
Slavka Krautzeka 83/A  
51000 Rijeka, Croatia  
Phone: +385 (51) 770 447  
Fax: +385 (51) 686 166  
[www.intechopen.com](http://www.intechopen.com)

### **InTech China**

Unit 405, Office Block, Hotel Equatorial Shanghai  
No.65, Yan An Road (West), Shanghai, 200040, China  
中国上海市延安西路65号上海国际贵都大饭店办公楼405单元  
Phone: +86-21-62489820  
Fax: +86-21-62489821

© 2012 The Author(s). Licensee IntechOpen. This is an open access article distributed under the terms of the [Creative Commons Attribution 3.0 License](#), which permits unrestricted use, distribution, and reproduction in any medium, provided the original work is properly cited.

IntechOpen

IntechOpen