

# We are IntechOpen, the world's leading publisher of Open Access books Built by scientists, for scientists

**4,800**

Open access books available

**122,000**

International authors and editors

**135M**

Downloads

Our authors are among the

**154**

Countries delivered to

**TOP 1%**

most cited scientists

**12.2%**

Contributors from top 500 universities



**WEB OF SCIENCE™**

Selection of our books indexed in the Book Citation Index  
in Web of Science™ Core Collection (BKCI)

Interested in publishing with us?  
Contact [book.department@intechopen.com](mailto:book.department@intechopen.com)

Numbers displayed above are based on latest data collected.

For more information visit [www.intechopen.com](http://www.intechopen.com)



# Impact of Severe Sepsis or Septic Shock on Drug Response

Marta Vázquez, Pietro Fagiolino,  
Cecilia Maldonado, Manuel Ibarra and Anna Boronat  
*Pharmaceutical Sciences Department, Faculty of Chemistry  
Therapeutic Drug Monitoring Service, University Hospital, Montevideo  
Uruguay*

## 1. Introduction

Several studies conducted in critically ill patients have demonstrated that inappropriate antibiotic treatment was associated with increased mortality (Niederman, 2006; Pea & Viale, 2009; Zilberberg et al., 2008). This fact was always related to the use of the wrong antimicrobial agent. However, the failure of a treatment might be due to inadequate doses that lead to sub-therapeutic concentrations at the infection site.

This last issue is relevant in patients with severe sepsis or septic shock as many factors can influence pharmacokinetic variability and consequently human drug response. Among these factors we can mention the pathology itself. Only the knowledge of the pathogenesis of sepsis can enable us to understand the variability of drug concentrations with the aim of a successful therapeutic outcome avoiding therapeutic failure or toxicity.

The sudden changes observed in severe sepsis or septic shock (increase in capillary permeability, edema formation, vasodilation and hypotension) and the therapeutic action taken to revert the situation (volume resuscitation, vasopressor agents) makes antibiotics or other drug concentrations difficult to interpret.

Due to the lack of stable disease conditions, and consequently marked variations in pharmacokinetics parameters, dose dosage in these patients is a great challenge.

The dynamic status of sepsis in critically ill patients results in alterations in pharmacokinetic parameters so it is of importance drug concentration assessment in this population, different from healthy volunteers or less severe ill patients.

The use of nomograms to provide estimates for dosages is not advisable as they assume normal pharmacokinetic parameters and due to instability of the system, pharmacokinetic parameters are subject to rapid changes.

As the measurement of total drug concentration (free drug plus protein-bound drug) is much easier and cheaper than free drug determination, therapeutic drug monitoring is usually based on total plasma concentrations. However, only the free drug is capable of diffusing into the biophase, only the free drug is responsible for the therapeutic effect. This fact has to be taken into account to see if the changes provoked by sepsis itself impact on both total drug and free drug in the same way. If this is not the case, defining dose regimens only by plasma total drug concentrations could be erroneous.

Measurement of the free drug in plasma is desirable but it is difficult to achieve in practice. Corrective algorithms (Bahn et al., 2002) have been proposed in order to predict unbound drug but with limitations if displacing drugs are present in the treatment. Salivary therapeutic drug monitoring in different populations has extensively been studied by our group (Maldonado et al., 2008, 2011). So, in view of this, this fluid may serve as an alternative to plasma free concentration in this population.

A theoretical multi-compartmental model designed by our group (Fagiolino et al., 2011), was used to understand the rapid changes that occur during sepsis causing highly variable drug concentrations.

The experimental results obtained with two different drugs: vancomycin and phenytoin used in the intensive care setting will be presented in order to study the impact of sepsis on their concentrations in accordance to this model.

## 2. Pathophysiological characteristics in critically ill patients with severe sepsis or septic shock and the influence on pharmacokinetics

Sepsis itself is characterized by an early response which implies the release of inflammatory mediators (tumor necrosis factor- $\alpha$ , interleukin 6 and chemokines) resulting in a detriment to the host. This constitutes the systemic inflammatory response syndrome (SIRS) (Dinarello, 2000). This release is counterbalanced by the opponent antiinflammatory molecules (interleukin 10, 4, etc) (Figure 1). This later response is referred to as the compensatory antiinflammatory response syndrome (CARS) (Bone, 1996). The magnitude of septic injury is determined by the balance of pro and antiinflammatory mediators.

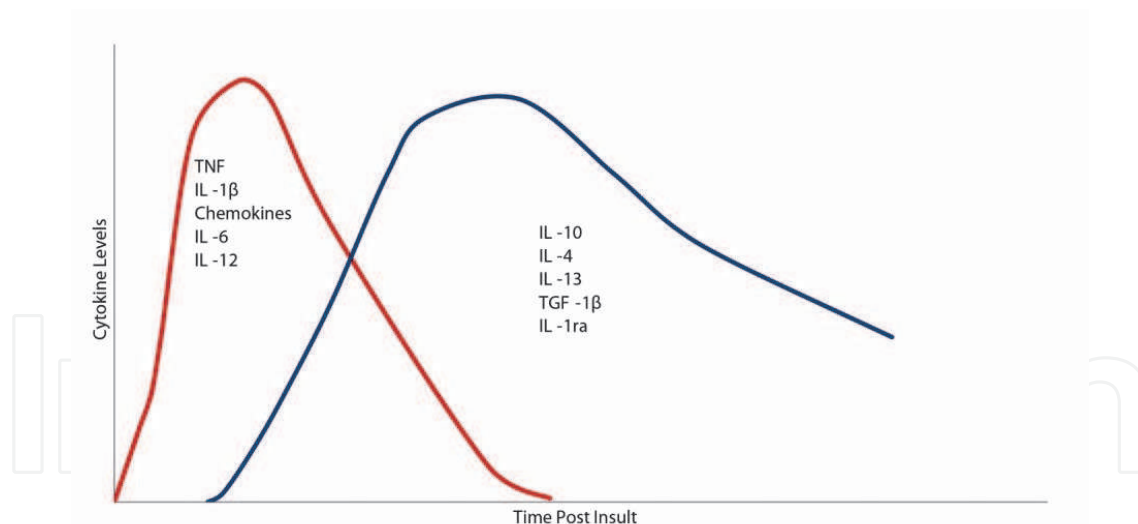

Fig. 1. Cytokines during sepsis. Figure adapted from Reddy et al., 2001. The red curve represents the mediators released during the systemic inflammatory response syndrome (SIRS). The blue curve represents the mediators released during the compensatory anti-inflammatory response syndrome (CARS).

At an initial stage, patients show enhanced inflammation responsible for tissue damage. The subsequent anti-inflammatory response makes the host more vulnerable for a secondary infection (Reddy et al., 2001). This first stage is the one that is going to be referred to in this chapter.

The initial mediators cause an increase in heart rate, an increased cardiac output, a decrease in systemic vascular resistance, an anomalous distribution of blood flow, reduced blood volume and tissue perfusion.

### **2.1 Alterations in tissue permeability**

Endothelial damage provoked by SIRS, may result in an increase in capillary permeability and interstitial edema formation. This generalized increase in capillary permeability may lead to presence of urinary albumin (Fuster-Lluch et al., 2008).

### **2.2 Glomerular hyperfiltration**

The study of the renal function in critically ill patients has always been focused on renal impairment. Nevertheless, glomerular filtration rate may be elevated in certain conditions such as sepsis (Fuster-Lluch et al., 2008). This could be due to the presence of a hyperdynamic circulatory situation by the increased cardiac output, indicating glomerular hyperfiltration and leading to an increase renal clearance of substances.

### **2.3 Alterations in protein binding**

Changes in the plasma protein binding of drugs during sepsis may be caused by many factors such as competition of endogenous substances for binding sites, changes in the binding characteristics that could be the consequence of changes in pH, etc. A reduction in the level of serum albumin in critically ill patients is often seen due to scarce protein intake, increased capillary permeability, reduced hepatic synthesis, renal loss (De Paepe et al., 2002).

The alterations observed in sepsis are of great impact on drug pharmacokinetics. The volume of distribution (Vd) and mainly the clearance (CL) of antimicrobials as well as of many others drugs suffer great variations during the disease. These disturbances can result in an increase in CL for hydrophilic and moderately lipophilic drugs if renal function is not compromised.

On the other hand, advanced status of sepsis is characterized by multiple organ dysfunction, with the kidneys and the liver involved at this stage. Kidney damage is very common and this will affect concentrations of renally-excreted hydrophilic drugs, resulting in higher concentration, total and free plasma concentrations. The effect of liver impairment on drugs eliminated by hepatic metabolism is not well defined and occurred mainly at a final stage as the liver has functional reserve.

## **3. Drug concentrations in sepsis due to the pathology itself or the medication used to resolve the situation**

An appropriate infection control is the priority to manage sepsis and requires an early adequate dose of antibiotics to achieve therapeutic concentrations at the site of infection.

Antibiotic therapy in critically ill septic patients usually consists of a broad-spectrum beta-lactam combined with a glycopeptide and /or an aminoglycoside.

Their greater efficacy occurs when antimicrobials concentrations are maintained above the minimum inhibitory concentration (MIC) of the pathogens responsible for the infection for extended periods.

Insufficient concentrations of antibiotics in the early phase of severe sepsis or septic shock are commonly observed in patients with normal renal function. Many authors have

confirmed sub therapeutic plasma concentrations of aminoglycosides (Beckhouse et al., 1988; Marik, 1993). So much is written in the literature about an increase in Vd in sepsis, which reduces in turn plasma antibiotic levels (Taccone et al., 2010a). For example for amikacin, the Vd is between 0.2 and 0.3 L/kg in healthy volunteers and in mild infections but in septic patients an increase of 60 % was found compared with normal ranges (Taccone et al., 2010b). But what is interesting from their studies was the fact that trough concentrations at steady state at the initial septic stage remain the same or were lower. Some authors reported lower areas under the plasma concentration -time curve (AUC) of these antibiotics during sepsis (Joukhadar et al., 2001). The latter observations confirm that the main cause of low concentrations of drugs during sepsis is mainly an increase in CL. Equation 1 refers to the mean steady state concentration, average steady state concentration ( $C_{avss}$ ) after multiple doses.

$$C_{avss} = \frac{AUC_0^\tau}{\tau} = \frac{FD/\tau}{CL} \quad (1)$$

Being CL the total clearance, F the bioavailability factor, D the dose,  $\tau$  the administration interval,  $AUC_{0-\tau}$  ( the AUC from zero to the last point of the administration interval).

Since drug administration in critically ill patients is mainly by intravenous route,  $F=1$ . So, any change in  $C_{avss}$  depends on CL only.

Due to hypoalbuminemia, highly and moderate protein-bound drugs reduce their total plasma concentration but their free plasma levels may also be reduced in sepsis.

If renal or intestinal excretion clearance predominates, a significant decrease in free plasma levels is expected because of the increased generalized permeability at capillaries and increased blood flow fraction derived to these zones.

So, an important fall in concentrations, even free concentrations in plasma, suggests an important increase in CL. This fact could be due to the following reasons:

1. Increase in capillary renal permeability
2. Increase in renal blood fraction
3. Increase in renal cardiac output affecting mainly highly renally extracted drugs.

This is the case of beta-lactams (penicillins, cephalosporins, carbapenems, monobactams), glycopeptides, aminoglycosides which are hydrophilic or moderate lipophilic drugs and can be extrapolated to any drug with the same characteristics.

If hepatic metabolic clearance or hepatic excretion clearance is the main route of elimination, then a discrete free drug level reduction would be expected. This is because hepatic blood flow fraction does not change in sepsis (De Paepe et al., 2002) and the increased capillary permeation in the liver does not change the normal unrestricted diffusion through sinusoid wall. This is the case for some lipophilic antibiotics and could be the case for any other drug with the same behavior.

New sepsis treatment strategies, mainly immune stimulatory therapy, have improved outcomes significantly (Lolis & Bucala, 2003). Nevertheless, antimicrobial therapy is still probably the most influential factor. So, prompt initiation of the correct antibiotic therapy is the cornerstone of therapy in sepsis.

Not only the sudden changes observed in severe sepsis or septic shock (increase in capillary permeability, edema formation, vasodilation and hypotension) make antibiotics or other drug concentrations difficult to analyze, but also the therapeutic action taken to resolve the situation (volume resuscitation, vasopressor agents) plays an important role.



Patients with severe sepsis or septic shock need replacement of the fluid to keep the arterial blood pressure for adequate organ perfusion (Choi et al., 1999). Changes in the water volume caused by the administration of large volumes of fluids, will affect antibiotics that distribute to the extracellular space fluid.

Administration of fluids for volume resuscitation such as crystalloids or colloids, causes an increase in aqueous volume leading to an increase in  $V_d$  of hydrophilic drugs. This dilution in drug concentrations is compensated by a slower elimination of drug. Consequently, no changes in CL could be observed.

Vasopressors are usually used (Holmes et al., 2001). This may affect drug concentrations as well. Of note, glomerular hyperfiltration may be a consequence of inotropic agents when hypotension does not revert with fluid therapy.

It is worth noting that the extent of renal and non renal excretion clearance of a drug is the fundamental issue to keep in mind and not how hydrophilic a drug is. Interestingly, it was recently shown (Pea & Viale, 2009; Thallinger et al. 2008) that a lipophilic antibiotic, linezolid, does not reduce significantly its free or tissue level in patients with sepsis and septic shock in relation with healthy volunteers. The explanation was that the intracellular depot of the agent restores its cleared amount. However, in our opinion, no statistical differences were found mainly because of the high inter-individual variability observed among individuals.

Pharmacokinetic data reported in the literature (Slatter et al, 2001; Wagenlehner et al., 2003) reveal an important contribution of renal excretion in linezolid clearance (40% approximately). Therefore, the increased renal clearance in septic patients mentioned above should necessarily diminish free linezolid levels in relation with healthy volunteers. Comparing free plasma  $C_{avss}$  of healthy volunteers with septic patients results (Thallinger et al. 2008), a reduction in free plasma levels in severe sepsis could be observed ( $13.3 \pm 5.03$  mg/L and  $8.37 \pm 3.89$  mg/L respectively). This could be clinically relevant and may be significant in the same individual. So, standard doses of this antibiotic may be inadequate to reach therapeutic free plasma concentrations

#### 4. Antibiotic administration strategies

It should not be overlooked that bacteria can grow again when antimicrobials concentrations fall below the MIC no matter the antibiotics used (time-dependent or concentration-dependent).

So it may be reasonable to suggest that maintenance of plasma trough concentrations above the MIC ought to be the goal of therapy in daily clinical practice for critically ill patient.

Many studies with different administration strategies for antibiotics were carried out (Petrosillo et al., 2010). One strategy was the case of extended infusion (over 3 to 4 hours) (Lomaestro & Drusano, 2005).

Continuous infusion may be the best approach to improve clinical outcomes in patients with severe infections (James et al., 1996; Lorente et al., 2009). The problem is the stability at room temperature of the drugs. Meropenem and imipenem are not good candidates. On the other hand, some other antibiotics are stable such as piperacillin/tazobactam; ceftazidime and vancomycin (Viaene et al., 2002).

So, not only the appropriate dose, usually larger doses than standard regimen are necessary, but also the right mode of administration could help to resolve this clinical situation.

It is evident that higher doses are required for optimal treatment as free plasma levels responsible for the pharmacological effect, decrease significantly.

Antimicrobials concentrations in septic patients were determined in different studies (Table 1) and thus pharmacokinetic data could be inferred.

Several authors found that antibacterial concentrations of these antibiotics are easily achievable with continuous infusion, thus representing an effective alternative dosing regimen to infusion bolus.

In a recent study (Roberts et al., 2009), continuous versus intermittent infusion of meropenem in critically ill patients with sepsis and without renal dysfunction was compared. In this study, continuous infusion was more successful in achieving the target concentrations despite meropenem instability.

Antibiotics	Suggested doses	Analytical techniques
<b>Piperacillin-tazobactam</b> (Petrosillo et al., 2010; Taccone et al., 2010a)	A loading dose of 2g, then 8g by continuous infusion over 24 h	High performance liquid chromatography with diode array detection
<b>Meropenem</b> (Taccone et al., 2010a)	2g every 8 hours	High performance liquid chromatography with diode array detection
<b>Ceftazidime</b> (Benko et al., 1996; Taccone et al., 2010a)	2 g loading dose followed by a 3-g continuous infusion over 24 h	High performance liquid chromatography with diode array detection
<b>Cefepime</b> (Lipman et al., 1999; Taccone et al., 2010a)	1g every 4 hours	High performance liquid chromatography with diode array detection
<b>Amikacin</b> (Taccone et al., 2010b)	A loading dose $\geq 25$ mg/kg	Fluorescence polarization immunoassay (TDx, Abbott Laboratories, IL, USA)
<b>Gentamicin</b> (Petrosillo et al., 2010)	7 mg /kg once daily	Fluorescence polarization immunoassay (TDx, Abbott Laboratories, IL, USA)
<b>Vancomycin</b> (Vázquez et al., 2008)	1 g loading dose followed by a 3-g continuous infusion over 24 hours	Fluorescence polarization immunoassay (TDx, Abbott Laboratories, IL, USA)
<b>Teicoplanin</b> (Brink et al., 2008)	Loading doses of 6 mg/kg every 12 hours for 48 h	Fluorescence polarization immunoassay (TDx, Abbott Laboratories, IL, USA)

Table 1. Antibiotics used in critically ill patients, dose recommendations and analytical techniques used to measure their levels

## 5. Background information of vancomycin and phenytoin

Vancomycin is a glycopeptide antibiotic used to treat Gram-positive infections and in particular, methicillin-resistant Staphylococcal species. Therapeutic drug monitoring of vancomycin is commonly based on trough and peak determinations. However, a continuous infusion of vancomycin was reported in the literature (James et al., 1996) and it was the mode of administration in our patients with good outcomes and with the advantage of adjusting the dose easily, proving to be even safer and more effective than intermittent administration.

In critical care units, intravenous phenytoin is the first - line drug in prophylaxis or suppression of seizures. For lipophilic drugs and non significant ionized at biological pH range, the total concentration of drug in saliva is equal to free drug concentration in plasma (Al Zaabi et al., 2003) after loading doses and therefore more reflective of drug concentration in the biophase. So saliva could be a better surrogate for free drug levels, becoming a more advantageous monitoring fluid.

Both drugs are bound to albumin: 50% and 90% for vancomycin and phenytoin respectively. Vancomycin is mainly excreted by the kidneys (80%), whereas hepatic metabolism is predominant for phenytoin with less than 5% excreted as unchanged drug in the urine (Letteri et al., 1971). CYP2C9 and CYP2C19 are the main enzymes responsible for phenytoin elimination (Levy, 1995) and their low distribution in the gut suggests an hepatic metabolism for this drug (Läpple et al., 2003). Phenytoin is also a multidrug resistance protein (MRP2) substrate (Potschka et al., 2003) and is capable of inducing these transporters after multiple doses (Lombardo et al., 2008).

## 6. Pharmacokinetic modelling

The multi-compartmental model, shown in Figure 2, reflects the pharmacokinetic factors associated with the use of vancomycin and phenytoin in critically ill patients with sepsis.

As it can be observed, different processes of transference of mass could take place after intravenous drug administration, depending on the drug considered. For instance, phenytoin has lower intestinal and negligible renal elimination pathways, while vancomycin has major renal and minor splanchnic excretion processes with practically null intestinal and renal reabsorption of drug. Firstly, the drug enters the body directly into the blood stream which is located within the Central Blood-Plasma compartment. From here the drug is distributed to different extravascular spaces according to the fraction of total blood flow destined to each organ (red arrows). Hence, the higher the blood flow fraction delivered to an organ is, the higher the fraction of total molecules of drug delivered to the corresponding tissue is. This last issue is very important to understand the impact that vasodilatation could have on regional drug distribution. If kidneys receive an increased fraction of the cardiac output, all elimination processes taking place in these organs increase. The same could be the case for the intestinal uptake of drug from blood compartment. At the liver region, the uptake by hepatocytes suffers only a little change. Since hepatic blood flow fraction is regulated by both portal and arterial supply, acting in a compensated way, then drug transference could remain unchanged.

The most important change in sepsis is the increase in capillary permeability. This happens in all the vessels, and consequently there will be a generalized escape to the extravascular space, including the eliminating organs. For this reason, drug clearance is the main



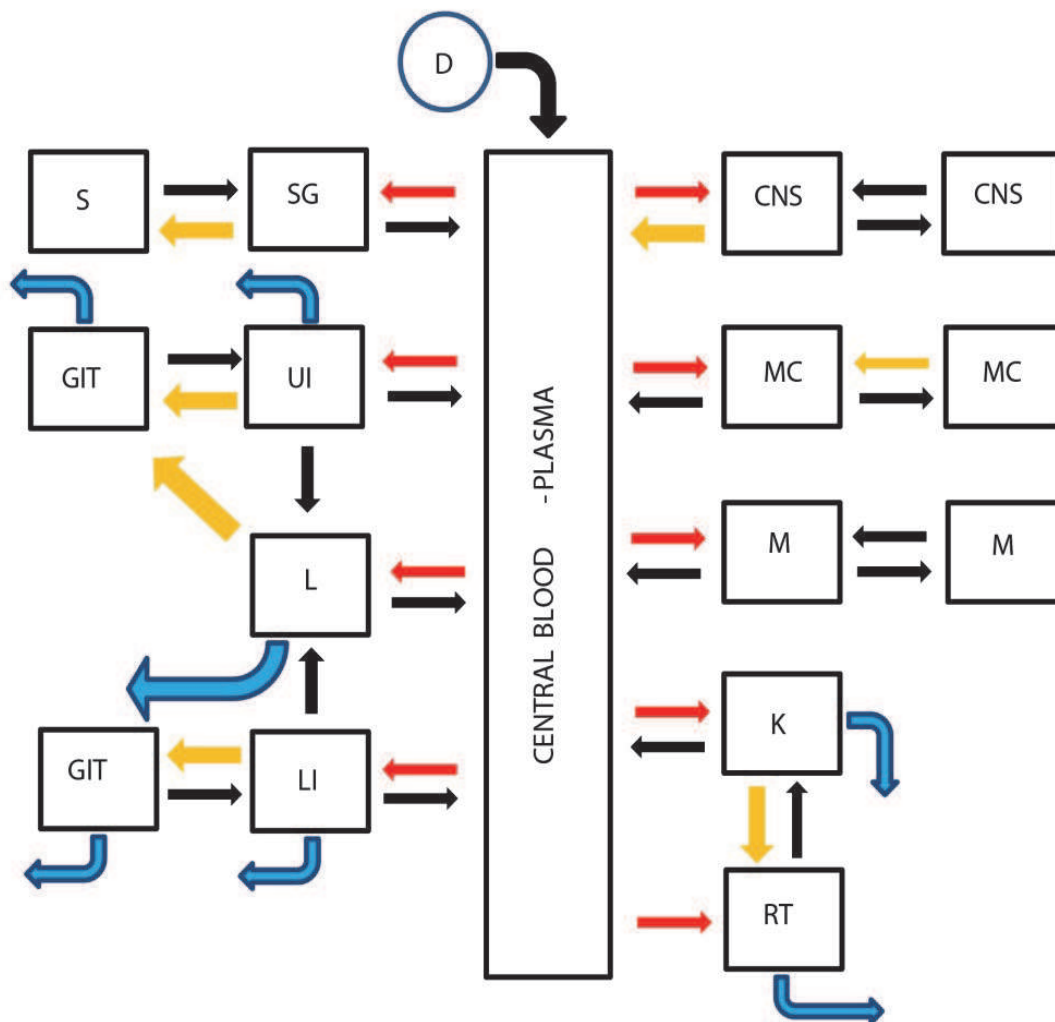

Fig. 2. Multi-compartmental model to explain drug variations during sepsis. Yellow arrows indicate efflux pumps. Red arrows represent blood flow and blood flow fraction to the different zones and blue arrows drug elimination. Some organs/tissues can be represented: (UI) upper intestine; (LI) lower intestine; (L) liver; (K) kidney; (RT) renal tubule; (GIT) gastrointestinal tract; (SG) salivary gland, (S) saliva; (M) muscle; (MC) myocardium; (CNS) central nervous system. (D) is the dose.

pharmacokinetic process affected by this change. Distribution into the intracellular spaces is not affected because both solute and solvent diffuse outside the vessels, so drug concentrations in plasma and in the interstitium remain unchanged. Secretions of fluid containing the drug increase through all secretory organs (gastrointestinal tract, kidneys) and consequently drug excretion increases. Fluid resuscitation does not reverse this phenomenon, because it just re-establishes blood pressure, but the increased clearance of drug persists. In the model, arrows getting mass of drug out of the blood compartment would increase, and those returning it back would decrease.

Loss of plasma proteins from the body, due to the increased permeability and increased clearance of proteins, produces a decrease in plasma protein concentrations. So, a decreased capacity to retain drug in the vasculature contributes to diminish even more drug levels in plasma and all over the body.

To sum up, free drug concentration in plasma decreases during sepsis because of an increased clearance. Total plasma drug concentration could decrease to a greater extent depending on the capacity of plasma protein to bind the drug. If there is a low binding capacity, the decrease in total drug concentration could be significantly higher than its respective free level decrease.

Since phenytoin is mainly eliminated by metabolism, and the hepatic clearance is its major route of elimination, a small decrease in free drug levels could be expected because of an increased blood flow fraction destined to both the intestine and the kidneys. However, saturation in plasma protein binding could be attained in hypoalbuminemic septic patients and then total plasma drug level may be decreased to a greater extent, even though non-significant clinical consequences should be expected. As the figure shows, certain arrows are painted in yellow, denoting a process mediated by efflux carriers. Since phenytoin is a MRP2 substrate, and it could induce its expression after chronic administration, different consequences either in clearance (Fagiolino et al. 2011), or in brain distribution, or in saliva excretion, could be envisaged. Readers should be aware of these increases in yellow arrows to deduce the pharmacokinetic and the therapeutic impact, and the corresponding drug monitoring using free plasma or saliva concentrations.

## 7. Experimental results

During sepsis the release of inflammatory mediators during the initial stage often results in detrimental effects to the host. The endothelial damage provoked by leucocytes, prostaglandins, leukotrienes or cascade activated complement leads to a generalized increase in capillary permeability and interstitial edema. Abnormalities in the microcirculation result in vasodilation and hypotension.

### 7.1 Vancomycin

The increase in permeability provokes an increase in renal clearance, thus there is a drop in both total and free plasma concentrations. Due to the hydrophilic characteristics of the drug, the tubular reabsorption is scarce and renal excretion is the augmented elimination pathway.

Vasodilation taking place mainly in the splanchnic and renal region would also produce an increase in drug clearance. In the case of critically ill patients in resting position, the blood flow to this area is already increased, so supplementary reduction in drug concentration is negligible.

Edema and hypovolemia have no further effect on the already low total drug concentrations.

Our data revealed no changes in protein binding for vancomycin. The comparison of the free fraction between 36 patients with sepsis and 24 patients without sepsis (all of them with normal renal function) showed no significant differences. The values obtained (mean  $\pm$  SD) were  $34.6 \pm 6.3\%$  and  $34.5 \pm 5.9\%$  respectively (Boronat, 2006). In the septic group a fall in free plasma concentration was observed even though daily doses were higher.

So the fall in vancomycin concentrations, even free concentrations, is mainly due to increased capillary permeability. Only with the eradication of the infection this situation can be reverted. Meanwhile, a higher dose should be administered (Vázquez et al, 2008).

Volume resuscitation did not have impact on free drug concentration but catecholamine administration reverted the slight impact that vasodilation could have on the already low free plasma concentrations.

Importantly, with deterioration in the clinical condition of the patient, lower plasma levels of vancomycin were observed. Conversely, an improvement in the clinical outcome was associated with increases in vancomycin plasma levels.

In this context, daily monitoring of plasma levels of this drug is mandatory to manage the infection.

## 7.2 Phenytoin

Due to its predominant hepatic elimination, changes in free plasma concentrations caused by capillary permeability modifications are not expected.

Vasodilation in intestine and renal regions with increasing blood flow derived to these areas would not impact significantly on free plasma phenytoin concentration either.

Changes in protein binding were observed in our hypoalbuminemic critically ill patients (Ibarra et al, 2010). For phenytoin, low total blood levels correspond mainly to an increased free drug fraction. Mean free phenytoin fraction in these patients was significantly higher ( $0.169 \pm 0.080$ ) in comparison to the one reported for patients with normal albumin (0.10).

Thus, an increase in dose is not necessary and monitoring of the unbound concentration may be desirable.

Limited data are available about the enzymatic functionality during sepsis. De Paepe et al. (2002) reported the findings that long periods under hypoxic conditions decrease cytochrome P450 enzymes activity, but this could not be the case in septic patients because of the prompt hemodynamic and ventilatory measurements taken in order to maintain adequate organ perfusion. Then, conclusions about this issue are not so easily reached.

As the free drug determination is difficult and expensive to achieve in practice, salivary phenytoin monitoring may serve as an alternative to plasma free concentration monitoring in this population due to its good correlation with the effect.

Our results showed significant correlations between saliva (S) and free plasma (P) drug concentrations in critically ill patients when doses were administered for short periods of time. In some of them, when the treatment was maintained and high doses were given, a slight increase in S/P ratio was observed. Despite the strong correlation found between salivary and free plasma concentrations, the induction of efflux transporters in different organs (including salivary glands) by this antiepileptic in chronic treatments could explain the higher S/P ratio obtained.

## 8. Conclusions

There was consistency of the pharmacokinetic model presented and the clinical data. It could be stated that for hydrophilic drugs both renal and non renal excretion significantly increase in sepsis. Physiopathology of sepsis has little influence on free drug metabolic clearance, which is mainly affected by cardiac output distribution changes. Changes in protein binding should not be taken as a major constraint for achieving the therapeutic goal because these changes themselves, do not affect free drug levels in plasma or in the biophase. So, total blood level should not be taken into account to guide therapeutic management of critically ill patients.

In patients without renal impairment, and receiving hydrophilic antibiotics higher doses and continuous or extended infusions are the best approaches to improve clinical outcomes. In the case of vancomycin and according to our studies the recommended daily dose should be 3 g with later adjustments considering clinical evolution.

According to our experience, in neurologic critically ill patients receiving phenytoin, the increase in the loading dose, as a consequence of the diminished total plasma levels, more than a benefit, enhanced drug-related toxicities. In these cases, free plasma or saliva drug monitoring is advisable.

## 9. References

- Al Zaabi, M., Deleu, D. & Batchelor, C. (2003). Salivary free concentration of antiepileptic drugs: an evaluation in a routine clinical setting. *Acta Neurol Belg*, Vol.103, No.1, pp. 19-23, ISSN 0300-9009
- Bahn, HL., Burton, ME. & Sperling, MR.(2002). Interpatient and inpatient variability in phenytoin protein binding. *Ther Drug Monit*, Vol.24, No.3, (June 2002), pp.379-385, ISSN 0163-4356
- Beckhouse, MJ., Whyte, IM., Byth, PL., Napier, JC.& Smith AJ. (1988). Altered aminoglycoside pharmacokinetics in the critically ill. *Anaesth Intensive Care*, Vol.16, No.4, (November 1988), pp.418-422, ISSN 0310-057X
- Benko, AS; Cappelletty, DM., Kruse, JA. & RyBak, MJ. Continuous infusion versus intermittent administration of ceftazidime in critically ill patients with suspected gram-negative infections. (1996). *Antimicrob Agents Chemother*, Vol. 40, No.3, (March 1996), pp. 691-695, ISSN 0066-4804
- Bone, RC. (1996). Sir Isaac Newton, sepsis, SIRS, and CARS. *Crit Care Med*, Vol.24, No.7, (July 1996), pp.1125-1128, ISSN 0090-3493
- Boronat, A. (2006). Pharmacokinetic follow-up of antimicrobials therapies in different hospital populations. *Doctoral thesis*. (In Spanish). Faculty of Chemistry, University of the Republic, Uruguay.
- Brink, AJ., Richards, GA., Cummins, RR., Lambson, J. & G auteng Undersatnding Teicoplanin Serum levels (GUTS) study group. (2008). Recommendations to achieve rapid therapeutic teicoplanin plasma concentration in adult hospitalized patients treated for sepsis. *Int J Antimicrob Agents*, Vol. 32, No. 5, (November 2008), pp.455-458, ISSN 0924-8579
- Choi, PT., Yip, G., Quinonez, LG. & Cook, DJ. (1999). Crystalloids vs colloids in fluid resuscitation: a systematic review. *Crit Care Med*, Vol. 27, No.1, (January 1999), pp. 200-210, ISSN 0090-3493
- De Paepe, P., Belpaire, FM. & Buylaert WA. (2002). Pharmacokinetic and pharmacodynamic considerations when treating patients with sepsis and septic shock. *Clin Pharmacokinetic*, Vol. 41, No.14, (January 2002), pp.1135-1151, ISSN 0312-5963
- Dinarello, CA. (2000). Proinflammatory cytokines. *Chest*, Vol.118, No.2, (August 2000), pp.503-508, ISSN 0012-3692
- Fagiolino, P., Vázquez, M., Eiraldi, R., Maldonado, C. & Scaramelli, A. (2011). Influence of efflux transporters on drug metabolism. Theoretical approach for bioavailability and clearance prediction. *Clin Pharmacokinetic*, Vol. 50, No. 2, (February 2011), pp. 75-80, ISSN 0312-5963
- Fuster-Lluch, O., Gerónimo-Pardo, M., Peyró-García, R. & Lizán-García, M. (2008). Glomerular hyperfiltration and albuminuria in critically ill patients. *Anaesth Intensive Care*, Vol. 36, No.5, (September 2008), pp. 674-680, ISSN 0310-057X

- Holmes, CL., Patel, BM., Russell, JA. & Wallay, KR. (2001) Physiology of vasopressin relevant to management of septic shock. *Chest*, Vol. 120, No. 3, (September 2001), pp. 989-1002 ISSN 0012-3692
- Ibarra, M., Vázquez, M., Fagiolino, P., Mutilva, F. & Canale, A. (2010). Total, unbound plasma and salivary phenytoin levels in critically ill patients. *J Epilepsy Clin Neurophysiol*, Vol.16, No. 2, (April 2010), pp.69-73, ISSN 1676-2649
- James, JK., Palmer, SM., Levine, DP. & Rybak, MJ. (1996). Comparison of conventional dosing versus continuous-infusion vancomycin therapy for patients with suspected or documented gram-positive infections. *Agents Chemother*, Vol. 40, No.3, (March 1996), pp. 696-700, ISSN 0006-4971
- Joukhadar, C., Frossard, M., Mayer, BX., Brunner, M., Klein, N., Siostrzonek, P., Eichler, HG. & Muller, M. (2001). Impaired target site penetration of beta-lactams may account for therapeutic failure in patients with septic shock. *Crit Care Med*, Vol. 29, No.2, (February 2001), pp. 385-391, ISSN 0090-3493
- Läpple, F., von Richter, O., Fromm, MF., Richter, T., Thon, K., Wisser H., Griese EU., Eichelbaum, M. & Kivistö KT. (2003). Differential expression and function of CYP2C isoforms in human intestine and liver. *Pharmacogenetics*, Vol. 13, No.9, (September 2003), pp. 565-575, ISSN 0960-314X
- Letteri, JM., Mellk, H., Louis, S., Kutt, H., Durante, P. & Glasko, A. (1971). Diphenylhydantoin metabolism in uremia. *N Engl J Med*, Vol. 285, (September 1971), pp. 648-652, ISSN 0028-4793
- Levy, RH. (1995). Cytochrome P450 isoenzymes and antiepileptic drug interactions. *Epilepsia*, Vol. 36, Suppl.5, (May 1995), pp.:S8-S13, ISSN 0013-9580
- Lipman, J., Wallis, SC. & Rickard, C.(1999). Low plasma cefepime levels in critically ill septic patients : pharmacokinetic modeling indicates improved troughs with revised dosing. *Antimicrob Agents Chemother*, Vol.43. No. 10, (October 1999), pp. 2559-2561, ISSN 0066-4804
- Lolis, E. & Bucala, R. Therapeutic approaches to innate immunity: severe sepsis and septic shock. (2003).*Nature Reviews Drug Discovery*, Vol. 2, (August 2003), pp. 635-645, ISSN 1474-1776
- Lomaestro, BM.& Drusano, GL. (2005). Pharmacodynamic evaluation of extending the administration time of meropenem using Monte Carlo simulation. *Antimicrob Agents Chemother*, Vol. 49, No.1, (January 2005), pp. 461-463, ISSN 0066-4804
- Lombardo, L., Pellitteri, R., Balazy, M. & Cardile, V. (2008). Induction of nuclear receptors and drug resistance in the brain microvascular endothelial cells treated with antiepileptic drugs. *Curr Neurovasc Res*, Vol. 5, No. 2, (May 2008), pp. 82-92. ISSN 1567-2026.
- Lorente, L., Jimenez, A., Martin, MM., Iribarren, JL., Jimenez, JJ. & Mora, MM. (2009). Clinical cure of ventilator-associated pneumonia treated with piperacillin/tazobactam administered by continuous or intermittent infusion. *Int J Antimicrob Agents*, Vol. 33, No.5, (May 2009), pp. 464-468, ISSN 0924-8579
- Maldonado, C., Fagiolino, P., Vázquez, M., Rey, A., Olano, I., Eiraldi, E. & Scavone, C. (2008). Therapeutic carbamazepine (CBZ) and valproic acid (VPA) monitoring in children using saliva as a biologic fluid. *J Epilepsy Clin Neurophysiol*, Vol. 14, No.2, (March 2002), pp. 55-58, ISSN 1676-2649



- Maldonado, C., Fagiolino, P., Vázquez, M., Eiraldi, R., Alvariza, S., Bentancour, C. & Alvarez, P. (2011). Time-dependent and concentration-dependent upregulation of carbamazepine efflux transporter. A preliminary assessment from salivary drug monitoring. (2011). *Lat Am J Pharm*, Vol.30, No. 5, (November 2010), pp. 980-912, ISSN 0326-2383
- Marik, PF. (1993). Aminoglycoside volume of distribution and illness in critically ill septic patients. *Anaesth Intensive Care*, Vol. 21, No. 2, (April 1993), pp. 172-173, ISSN 0310-057X
- Niederman, MS. (2006). Use of broad-spectrum antimicrobials for the treatment of pneumonia in seriously ill patients: maximizing clinical outcomes and minimizing selection of resistant organisms. *Clin Infect Dis*, Vol. 42, Suppl.2, pp. S72-S81, ISSN 1058-4838
- Pea, F. & Viale, P. (2009). Bench-to-bedside review: appropriate antibiotic therapy in severe sepsis and septic shock-does the dose matter?. *Crit Care*, Vol. 13, No. 3, (June 2009), 214, ISSN 1364-8535
- Petrosillo, N., Drapeau, CM., Agrafiotis, M. & Falagas ME. (2010). Some current issues in the pharmacokinetic/pharmacodynamics of antimicrobials in intensive care. *Minerva Anestesiol*, Vol.76, No.7, (July 2010), pp. 509-524, ISSN 0375-9393
- Potschka, H., Fedrowitz, M. & Löscher, W. (2003). Multidrug resistance protein MRP2 contributes to blood-brain barrier function and restricts antiepileptic drug activity. *J Pharmacol Exp Ther*, Vol. 306, No.1, (March 2003), pp. 124-131, ISSN 0022-3565
- Reddy, RC., Chen, GH., Tekchandani, PK. & Standiford, TJ. (2001). Sepsis-induced immunosuppression. From bad to worse. *Immunologic Research*, Vol. 24, No. 3, (December 2001), pp.273-288, ISSN 0257-277X
- Roberts, JA., Kirkpatrick, CMJ., Roberts, MS., Robertson, TA., Dalley, AJ. & Lipman, J. (2009). Meropenem dosing in critically ill patients with sepsis and without renal dysfunction: intermittent bolus versus continuous administration? Monte Carlo dosing simulations and subcutaneous tissue distribution. *J Antimicrob Chemother*, Vol. 64, No.1, (July 2009), pp.142-150, ISSN 0066-4804
- Slatter, JG., Stalker, DJ., Feenstra, KL., Welshman, IR., Bruss, JB., Sams, JP., Johnson, MG., Sanders, PE., Hauer, MJ., Fagerness, PE., Stryd, RP., Peng, GW. & Shobe, EM. (2001). Pharmacokinetics, metabolism, and excretion of linezolid following an oral dose of [<sup>14</sup>C] linezolid to healthy human volunteers. *Drug Metab and Dispos*, Vol. 29, No.8, (April 2001), pp.1136-1145 ISSN 0090-9556
- Taccone, FS., Laterre, PF., Dugernier, T., Spapen, H., Delattre I., Wittebole, X., De Backer, D., Layeux, B., Wallemacq, P., Vincent JL. & Jacobs, F. (2010a). Insufficient  $\beta$ -lactam concentrations in the early phase of severe sepsis and septic shock. *Crit Care*, Vol. 14, No.4, (July 2010), R126, ISSN 1364-8535
- Taccone, FS., Laterre, PF., Spapen, H., Dugernier, T., Delattre I., Layeux, B., De Backer, D., Wittebole, X., Wallemacq, P., Vincent JL. & Jacobs, F. (2010b). Revisiting the loading dose of amikacin for patients with severe sepsis and septic shock. *Crit Care*, Vol.14, No.2, (April 2010), R53, ISSN 1364-8535
- Thallinger, C; Buerger, C., Plock, N., Kljucar, S., Wuenscher, S., Sauermann, R., Kloft, C. & Joukhadar, C. (2008). Effect of severity of sepsis on tissue concentrations of linezolid. *J Antimicrobial Chemother*, Vol. 61, No. 1, (January 2008), pp.173-176 ISSN 0305-7453

- Vázquez, M., Fagiolino, P., Boronat, A., Buroni, M. & Maldonado, C. (2008). Therapeutic drug monitoring of vancomycin in severe sepsis and septic shock. *Int J Clin Pharmacol Ther*, Vol. 46, No. 3, (March 2008), pp. 140-145, ISSN 0946-1965.
- Viaene, E., Chanteux, H., Servais, H., Mingeot-Leclercq, MP. & Tulkens, PM. (2002). Comparative stability studies of antipseudomonal beta-lactams for potential administration through portable elastomeric pumps (home therapy for cystic fibrosis patients) and motor-operated syringes (intensive care units). *Antimicrob Agents Chemother*, Vol. 46, No.8, (August 2002), pp. 2327-2332, ISSN 0066-4804
- Wagenlehner, FME., Wydra, S., Onda, H., Kinzig-Schippers, M., Sörgel, F. & Naber KG. (2003). Concentrations in plasma, urinary excretion, and bactericidal activity of linezolid (600 milligrams) versus those of ciprofloxacin (500 milligrams) in healthy volunteers receiving a single oral dose. *Antimicrob Agents Chemother*, Vol. 47, No.12, (December 2003), pp. 3789-3794, ISSN 0066-4804
- Zilberberg, MD., Shorr, AF., Micek, ST., Mody, SH. & Kollef, MH. (2008). Antimicrobial therapy escalation and hospital mortality among patients with health-care-associated pneumonia: a single center experience. *Chest*, Vol. 134, No. 5, (July 2008), pp. 963-68, ISSN 0012-3692

IntechOpen

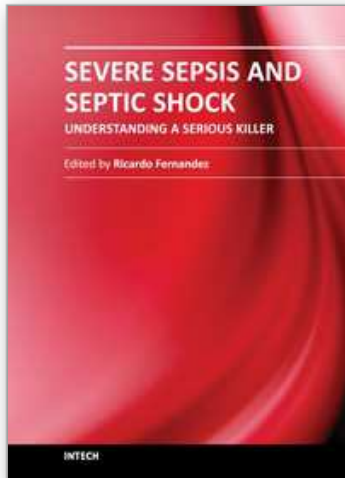

## **Severe Sepsis and Septic Shock - Understanding a Serious Killer**

Edited by Dr Ricardo Fernandez

ISBN 978-953-307-950-9

Hard cover, 436 pages

**Publisher** InTech

**Published online** 10, February, 2012

**Published in print edition** February, 2012

Despite recent advances in the management of severe sepsis and septic shock, this condition continues to be the leading cause of death worldwide. Some experts usually consider sepsis as one of the most challenging syndromes because of its multiple presentations and the variety of its complications. Various investigators from all over the world got their chance in this book to provide important information regarding this deadly disease. We hope that the efforts of these investigators will result in a useful way to continue with intense work and interest for the care of our patients.

### **How to reference**

In order to correctly reference this scholarly work, feel free to copy and paste the following:

Marta Vázquez, Pietro Fagiolino, Cecilia Maldonado, Manuel Ibarra and Anna Boronat (2012). Impact of Severe Sepsis or Septic Shock on Drug Response, *Severe Sepsis and Septic Shock - Understanding a Serious Killer*, Dr Ricardo Fernandez (Ed.), ISBN: 978-953-307-950-9, InTech, Available from: <http://www.intechopen.com/books/severe-sepsis-and-septic-shock-understanding-a-serious-killer/impact-of-severe-sepsis-or-septic-shock-on-drug-response>

**INTECH**  
open science | open minds

### **InTech Europe**

University Campus STeP Ri  
Slavka Krautzeka 83/A  
51000 Rijeka, Croatia  
Phone: +385 (51) 770 447  
Fax: +385 (51) 686 166  
[www.intechopen.com](http://www.intechopen.com)

### **InTech China**

Unit 405, Office Block, Hotel Equatorial Shanghai  
No.65, Yan An Road (West), Shanghai, 200040, China  
中国上海市延安西路65号上海国际贵都大饭店办公楼405单元  
Phone: +86-21-62489820  
Fax: +86-21-62489821

© 2012 The Author(s). Licensee IntechOpen. This is an open access article distributed under the terms of the [Creative Commons Attribution 3.0 License](#), which permits unrestricted use, distribution, and reproduction in any medium, provided the original work is properly cited.

IntechOpen

IntechOpen