

# We are IntechOpen, the world's leading publisher of Open Access books Built by scientists, for scientists

**4,800**

Open access books available

**122,000**

International authors and editors

**135M**

Downloads

Our authors are among the

**154**

Countries delivered to

**TOP 1%**

most cited scientists

**12.2%**

Contributors from top 500 universities



**WEB OF SCIENCE™**

Selection of our books indexed in the Book Citation Index  
in Web of Science™ Core Collection (BKCI)

Interested in publishing with us?  
Contact [book.department@intechopen.com](mailto:book.department@intechopen.com)

Numbers displayed above are based on latest data collected.

For more information visit [www.intechopen.com](http://www.intechopen.com)



## A WiMAX Network Architecture Based on Multi-Hop Relays

Konstantinos Voudouris<sup>1</sup>, Panagiotis Tsiakas<sup>1</sup>, Nikos Athanasopoulos<sup>1</sup>,  
Iraklis Georgas<sup>1</sup>, Nikolaos Zotos<sup>2,3</sup> and Charalampos Stergiopoulos<sup>1,2</sup>

<sup>1</sup>Department of Electronics, Technological Educational Institution of Athens, Attiki,

<sup>2</sup>Future Intelligence Ltd, Attiki,

<sup>3</sup>NCSR Demokritos, Attiki,

Greece

### 1. Introduction

It has become apparent in the recent years that in order for the next generation of wireless technology (whether this is WiMAX, LTE or any other 4G implementation) to be able to deliver ubiquitous broadband content, the network is required to provide excellent coverage, both outdoor and indoor, and significantly higher bandwidth per subscriber [Voudouris *et al.*, 2009]. In order to achieve that at frequencies above 2 and 3 GHz, which are targeted for future wireless technologies, network architecture must reduce significantly the cell size or the distance between the network and subscribers' antennas. While micro, pico and femto Base Transceiver Station (BTS) technologies reduce the cost of base-station equipment, they still rely on a dedicated backhaul. One solution introduced with the WiMAX 802.16j standard is the wireless Multi-hop Relay Station (MRS), intended to overcome these challenges. On one hand, it should be small, cost-effective and easy to install for enabling mass deployment in indoor and outdoor environments and creating relatively small areas with excellent coverage and high capacity availability. On the other hand, it does not require any dedicated backhaul equipment as it receives its capacity from centralized base-stations via the same resources used for the access service. In a setting where a MRS exists, enabling MIMO transmission, the link referred to needs to be specified. This means that, when a 2x2 setting is mentioned, there can be either two transmit antennas on the base station and two receive antennas on the relay station, or two transmit antennas on the relay station and two receive antennas on the subscriber's device [Chochliouros *et al.*, 2009]. Wireless Multi-hop Relay Stations (MRSs), when deployed in various sights, result in increased throughput or coverage. A general case, where a relay station can be used, is in situations with coverage constraints such as areas where there is presence of physical obstacles (e.g. buildings, forests), or in indoor coverage cases. Some examples are large office buildings, University campuses, and villages in unreachable areas on rockier uplands etc. Another scenario, where MRSs can be used, is for high mobility users with increased bandwidth requirements, such as trains with a great number of wireless users. Such a mobile subscriber will more likely have data rate degradations due to non-fixed position. In this case, a relay station can be considered as the most feasible solution in terms of cost and

easiness of installation in every public transport vehicle, providing increased coverage and throughput to mobile WiMAX users. In order to achieve certain bit error rate levels on the data transmitted to the subscribers, WiMAX uses adaptive modulation. In case the subscriber is far from the base station or the environment introduces a lot of interference, the modulation used will be adapted accordingly, reducing the available data rate of the user. The use of a relay station can improve the provided service to the end-user, since it can transcode the received signal from the base station increasing the data rate provided to that user. This scenario is applicable in suburban environments, where users are usually away from the base stations, as well as in environments with increased interference.

## 2. IEEE 802.16j protocol stack overview

In WiMAX the IEEE only defined the Physical (PHY) and Media Access Control (MAC) layers in 802.16 [IEEE 802.16, 2004]. This approach has worked well for technologies such as Ethernet and WiFi, which rely on other bodies such as the IETF (Internet Engineering Task Force) to set the standards for higher layer protocols such as TCP/IP (Transport Control Protocol / Internet Protocol), SIP (Session Initiation Protocol), VoIP (Voice over Internet Protocol) and IPSec (Internet Protocol Security). The main objective of the IEEE 802.16 standards is to develop a proper set of specifications of the air interface, while the WiMAX Forum defines the system profile, which is a list of selected functionalities for a particular usage scenario and overall wireless network architectures [Nakamura, 2008]. The sector continues to innovate in many ways; one of these is the development/promotion of new standards to solve "open" problems. Such an initiative (which is currently of extreme interest) is the development of the Multi-hop Relay Standard, IEEE 802.16j. This is being developed to provide low cost coverage in the initial stages of network deployment and increased capacity when there is high utilisation of the network. The standard has been identified with a better feasibility and efficiency due to the similarities in the MAC and PHY layers and the support of fast route change [Harmonized Contribution 802.16j]. The standard is expected to have significant impact in new 802.16 rollouts.

When deploying an IEEE 802.16j based WiMAX network, this can be considered as a cellular network since they both have the same design principles [Lin *et al.*, 2007]. The standard specifies a set of technical issues in order to enhance previous standards with the main objective of supporting relay concepts [Zeng *et al.*, 2008].

The 802.16j standard defines an air interface between a Multi-hop Relay-Base Station (MR-BS) and a Relay Station (RS) [Okuda *et al.*, 2008]. Its most important technical issues are listed as follows: Centralized vs. distributed control; Scheduling; Radio resource management; Power control; Call admission and traffic shaping policies; QoS based on network wide load balancing and congestion control; Security, and; Management. Besides these issues, when it comes to network deployment the main objective remains the optimal placement of the RSs. Operators are mainly concerned about operating costs, revenues and the pay-off periods for their investments; but the quality of services offered, is also an important issue for them. The IEEE 802.16j protocol layering for simple RS is shown in Fig.1. Principles of layers are briefly discussed as follows: Principles of layers are briefly discussed as follows: The MAC Converge Sub-layer (CS) is primarily used to "map" any data received from the upper layers (e.g. IP, Ethernet) to an appropriate MAC connection, to manage data

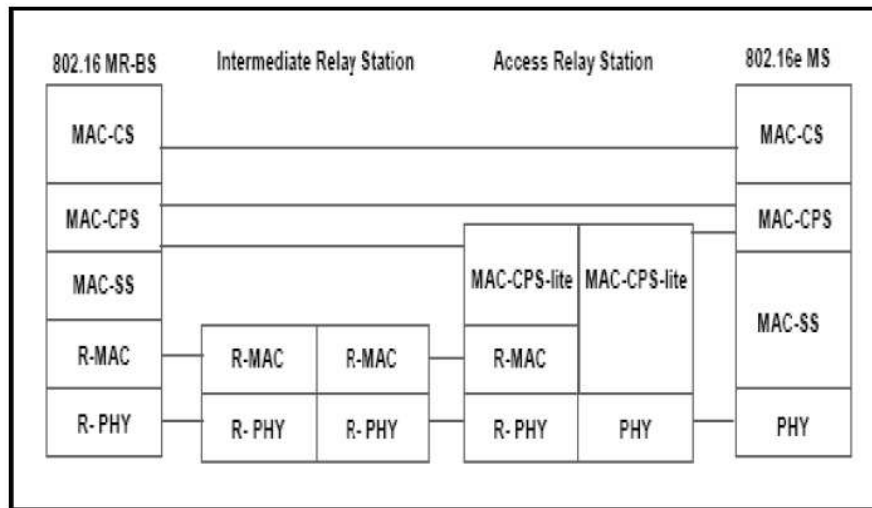

Fig. 1. IEEE 802.16j Protocol layering for simple RS

flow from the upper layer and to ensure that QoS requirements are fulfilled. More specifically, the CS accepts data from the network layer through the CS Service Access Point (SAP) and performs data classification into the appropriate MAC Service Data Units (SDUs). A "classifier" is an entity which selects packets based on the content of packet headers and categorises them according to a set of "matching criteria" (such as destination IP address). The external higher-layer Protocol Data Units (PDUs) entering the CS are checked against those criteria and accordingly delivered to a specific MAC connection. The MAC Common Part Sub-layer (CPS) is a connection oriented protocol. Contrarily to previous wireless network technologies (such as IEEE 802.11), it does provide QoS guarantees. It receives the MAC SDUs from MAC SAP; next, it delivers the MAC PDUs to a peer MAC SAP according to the requested QoS, to perform various transport functions (i.e. packing, fragmentation and concatenation). Each MAC PDU is identified by a unique connection identifier (CID). In the scope of past IEEE 802.16 standard versions, in 2004, an operation has been defined where multiple MAC PDUs could be concatenated and comprised into a single burst for transmission purposes. These PDUs had to be encoded and modulated, by using the same PHY (i.e. using the same burst profile); however they could be associated with subscriber stations. The position of each burst into the DL (downlink) frame has been specified by DL-MAP2, which contained additional Information Elements (IEs). The IEs specify the CID of the receiver, the burst profile used, the start time of the burst and a bit indicating whether an optional preamble is present. The IEEE 802.16e standard has further extended the DL MAP IE of legacy IEEE 802.16, in order to carry the identifiers of multiple connections (CIDs) in a single IE. However, the last missing link for enabling efficient MAC PDU concatenation on relay link is the capability of supporting multiple connections using one uplink (UL) information element. Several approaches have been made, until now, to extend the UL MAP3 IE for relay link. The MAC Security Sub-layer (MAC-SS) handles security issues such as authentication, key exchange and privacy by encrypting the connections between BS and subscriber station. It is based on the Private Key Management (PKM) protocol, which has been enhanced to "fit" the IEEE 802.16 standard. At the time a subscriber connects to the BS, they perform mutual authentication with public-key cryptography using X.509 certificates [Chokhani *et al.*, 1999]. The payloads themselves are encrypted by using a symmetric-key

system, which may be either DES (data encryption standard) with cipher block chaining or triple DES with two keys. The Relay MAC (R-MAC) Sub-layer has been introduced in the IEEE 802.16j standard. It provides efficient MAC PDU relaying/ forwarding and control functions, (such as scheduling, routing, and flow control). It is applicable to the links between MR-BS and RSs and between RSs. The Relay Physical (R-PHY) layer provides definition of physical layer design, (i.e. sub-channelization, modulation, coding, etc.), for links between MR-BS and RS and between RSs. The IEEE 802.16j standard has extended the past IEEE 802.16e frame structure to support in-band BS-to-RS communication. A high level diagram of the 802.16j frame structure in TDD (Time Division Duplex) OFDMA PHY mode is shown in Fig.5. The frame structure supports a typical two-hop relay-enhanced communication, where some MSs are attached to a RS and communicating with a BS via the RS, and some MSs connected directly to the BS.

In Fig.2, the horizontal dimension denotes time and the vertical dimension denotes frequency. Frame sections in grey denote receive (Rx) operation, whereas sections in white denote transmit (Tx) operation. The BS and RS frames are subdivided into DL and UL subframes in order to support TDD operation. Both DL and UL subframes are further subdivided into MS and RS zones. The MS zones, supported at both the BS and RS, are backwards compatible with the 802.16e standard. The RS transmits to MSs in its coverage in the DL MS zone and receives control and data from the BS in the adjacent DL RS zone. Each MR-BS frame begins with a preamble followed by a FCH (Frame Control Header) and the DL-MAP and possibly UL-MAP. The DL subframe shall include at least one DL access zone and may include one or more DL relay zones. The UL subframe may include one or more UL access zones and it may include one or more UL relay zones. A relay zone may be utilized for either transmission or reception, but the MRBS shall not be required to support both modes of operation within the same zone.

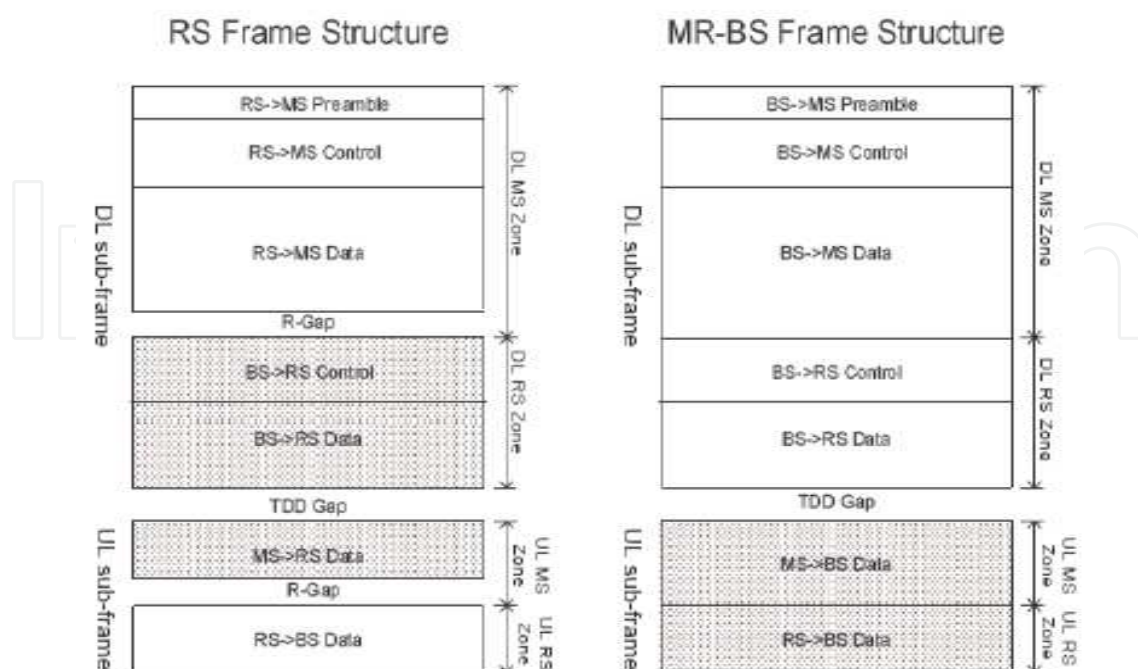

Fig. 2. OFDMA 802.16j frame structure.

### 3. Relay network overview

The following section provides an overview of a Relay Network in WiMAX Network build-out. It provides a general overview of the Relay network applications and benefits, an overview of the network architecture and the resulting requirements for the Relay node to fit into this architecture, and an overview of the required Protocol Stack to be run on the Relay node in the network.

#### 3.1 Relay network general overview

There are various choices available for operators deploying WiMAX networks to improve indoor or outdoor coverage or to increase network capacity. These choices include various types of base stations: macrocells, microcells, or picocells in an outdoor environment, picocells in public indoor locations or within enterprise buildings, and femtocells for residential. The primary difference between these cells (performance-wise) is the size of coverage. Macrocells are the base stations with longest range, but are also the most expensive to purchase, deploy and maintain. Micro, pico and femto base stations are used to fill in coverage gaps and establish coverage in buildings where the macrocell signals can hardly penetrate. A significant side-effect of placing a large number of base stations in a region is that each needs a dedicated broadband backhaul connection. Micro, pico, and femto cells can use either wireline or wireless links for their backhaul, depending on the cost, availability and scalability of different solutions. In particular, they can support in-band backhaul to enable operators to use their spectrum holdings to carry backhaul traffic to the nearest macro base station or to the nearest microcell or picocell with wireline backhaul.

The IEEE 802.16j Mobile Multi-hop Relay (MMR) specifications are aimed to extend base station reach and coverage for WiMAX networks, while minimizing wireline backhaul requirement. The relay architecture will allow operators to use in-band wireless backhaul while retaining all the standard WiMAX functionality and performance.

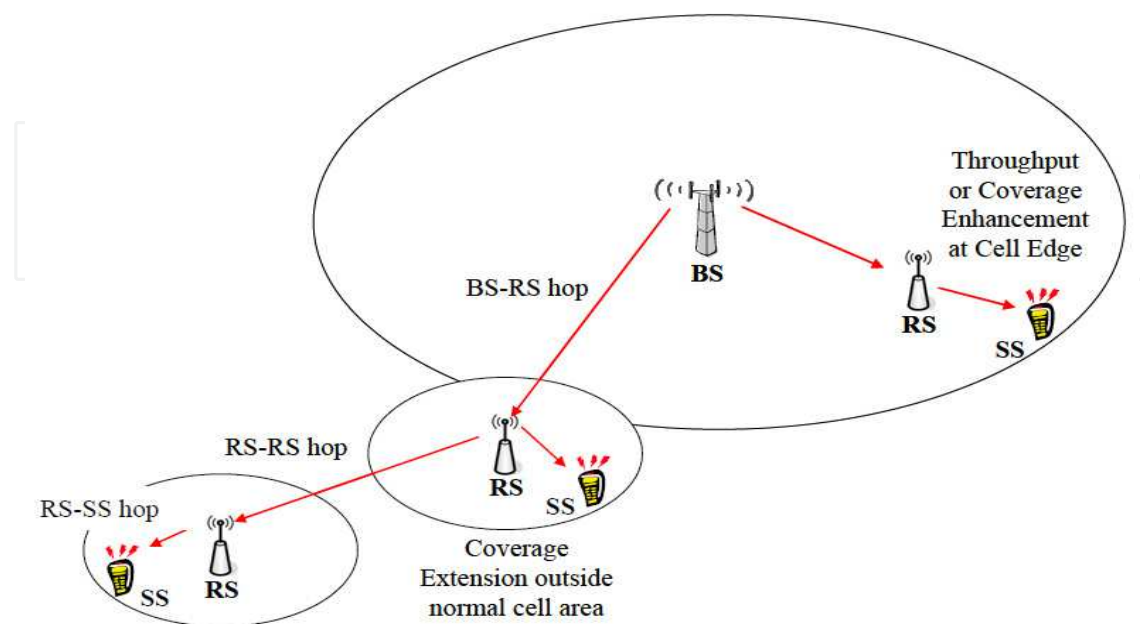

Fig. 3. Throughput or coverage enhancement

For example, in the previous figure, the MMR base station provides the primary area of coverage. It also has a backhaul connection, such as leased copper, fiber optics, or microwave radio link. The relay station extends the base station coverage. A mobile subscriber station (SS) can connect to a base station, an MMR base station (MRBS) or a Relay Station (RS).

The figure below shows additional usage scenarios for BS+RS deployment. These include coverage hole elimination within cell area (right); and temporary deployment for disaster/emergency situations and for special events (left).

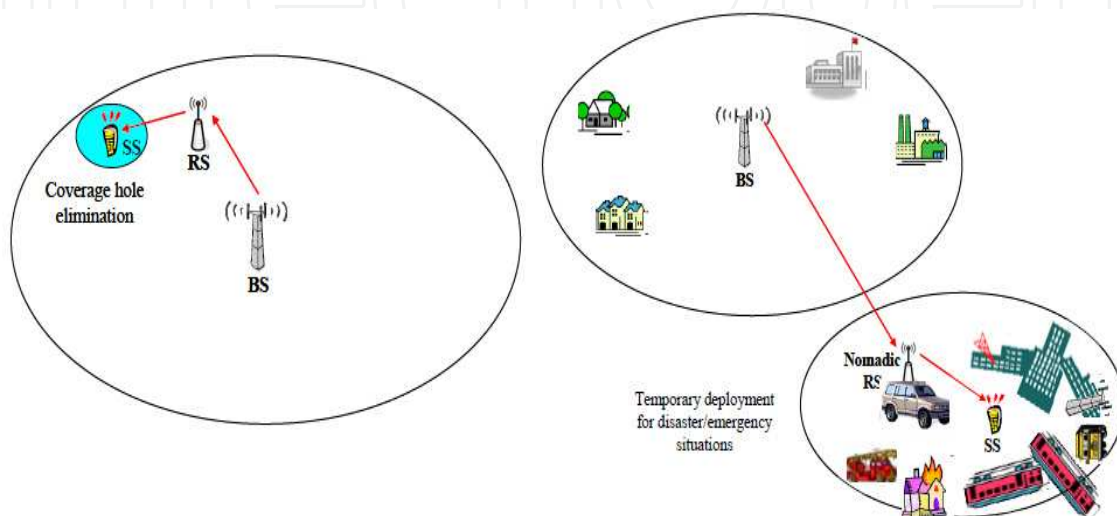

Fig. 4. Coverage hole elimination; Temporary deployment

Relay can be used in WiMAX networks for improving the coverage at the edge of the cell or for providing coverage to an area outside the coverage area of the cell. Relay can also be used for solving specific coverage problem within the coverage area of the cell ("hole filler") or provide coverage to tunnels and roads. Relay can also be used for adding throughput to certain "hot spot" areas within the coverage area of a cell. One important usage that has drawn growing attention in recent years is "In-building" or "indoor coverage". The growing traffic generated by indoor users can be met by the use of several types of relays and system configurations ranging from dedicated outdoor relays to distributed indoor relays with a multi hop configuration. A relay mounted on a vehicle can provide continuous service to users located in the vehicle while communicating and keeping continuity by performing continuous handover with base stations along the way. Relay can also be used on temporary basis, providing additional capacity to certain locations where a heavy traffic is expected for a limited time such as sporting events, concerts, and other events where a large crowd is expected to gather. Relay can also be deployed by first responders in order to provide coverage in an area where rescue operations take place.

### 3.2 Relay network architecture overview

Multi-hop Relay (MR) is a deployment that may be used to provide additional coverage or performance advantage in an access network. In MR networks, the Multi-hop Relay BS (MR-BS) is connected to several Relay Stations (RS), in a multi-hop topology, in order to enhance the network coverage and capacity density. Traffic and signalling between the SS and MR-

BS are relayed by the RS thereby extending the coverage and performance of the system in areas where RSs are deployed. Each RS is under the supervision of an MR-BS. In a system with more than two hops, traffic and signalling between an access RS and MR-BS may also be relayed through intermediate RSs. The RS is fixed in location. The SS may also communicate directly with the MR-BS. The following figure illustrates the MR-BS and two-hop RS deployment. For each of the RS there is an ACCESS link that covers the current cell and a BACKHAUL link to the next cell.

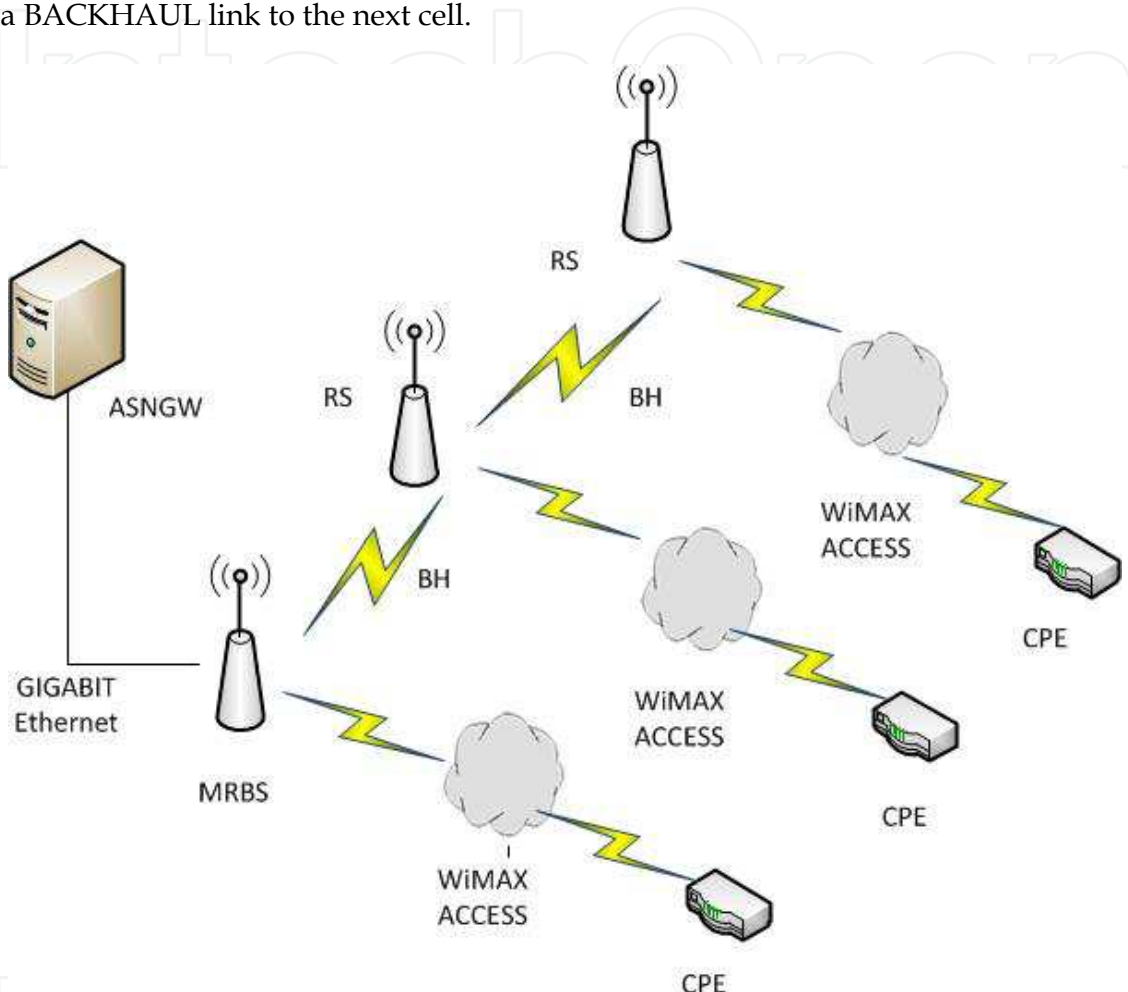

Fig. 5. MR-BS and RSs deployment

When considering relay stations, a distinction can be made between transparent and non-transparent relay stations. The main difference between these RS types is the way that the MS regards its serving or super-ordinate RS. When the super-ordinate RS of the MS is a transparent RS, then the MS regards the MRBS as its serving BS. From the MS point of view the transparent RS in the middle does not exist. The transparent RS assists the MRBS-MS communication link without any visibility of the RS to the MS. In case the super-ordinate RS of the MS is a non-transparent RS, then the MS regards its super-ordinate RS as if it is its serving 802.16e BS. Non-transparent relay stations can employ either distributed scheduling or centralized scheduling. When using distributed scheduling, the RS makes decisions about resource allocation, CID allocation, and MAP building regarding subscribers (and RSs) in its control. When using centralized scheduling, the MRBS makes those decisions for all the RSs under its supervision, and communicates these decisions to all RSs, which execute them.



## 4. Relay networking architecture options

This section lists several options for modifying the WiMAX architecture to enable support for relay. Each option is presented and its main cons and pros are listed. It begins with a discussion regarding MAC-based relay, as suggested by 802.16j, and then proceeds to network-based relay.

### 4.1 MAC-based relay

The first architecture option to consider is called "MAC-based relay". MAC-based relay is the approach used by 802.16j non-transparent mode. In this approach, the backhaul link between the Relay Station (RS) and the Multi-hop Relay Base Station (MRBS) is contained within the MAC (L2) layer. In most aspects, the ASN-GW is unaware of the fact that a MS is connected to the BS via a RS. Rather, the MRBS behaves as if the MS is registered with it directly. In this approach, no networking modifications are required to support relay traffic (though some modifications may be needed for RRM and other aspects, see below). From a networking perspective, the RS does not behave like a BS. The GRE tunnel used to carry the Service Flow is terminated at the MRBS and not at the RS. 802.16j MAC-based relay can support multi-hop (3-hop and more) relay without network modifications.

Pros:

- No network modifications.
- Lower latency for relay transport
- Easier to implement QoS constraints, because RS-MRBS link uses dedicated MAC, which can contain more information than available over R6.

Cons:

- RS-MRBS link not compliant to 802.16e MAC
- RS functionality does not build over existing WiMAX capabilities. Mobility, RRM needs to be modified to support relay.

### 4.2 Network-based relay

The MAC-based relay has one important drawback: The air interface between the RS and the MRBS is not 802.16e compliant. While modifying an existing BS networking capabilities is relatively painless, modifying an existing 802.16e BS to support new MAC features (such as 802.16j) is much more complex. Likewise, upgrading a deployed 802.16e network to support relay is much easier if it does not involve radio modifications. In addition, there is also decreased availability of existing test equipment. This makes development costs much higher for MAC variants. It is also important to note that 802.16j standard was not yet presented to NWG. Expected NWG activities may include RRM, network-assisted distributed scheduling and handover support. Therefore, we need to consider Network-based relay options, where the RS is composed of interconnected WiMAX BS and a WiMAX MS. The link between the RS and the MRBS is 802.16e-compliant, and networking elements are used to enable relay. Using 802.16e compliant air interface simplifies development and deployment. A RS with two 802.16e-compliant air interfaces (one for access and one for

backhaul) is called Simultaneous Transmit and Receive (STR) Relay. Network-based relay options are presented in the following sections.

### 4.3 QoS over relay

WiMAX defines QoS parameters – most importantly, maximum tolerable latency and jitter – over the air interface connections. When combined with QoS mechanisms over the wireline backbone, or when the wireline backbone is good enough, the WiMAX QoS can provide predictable end-to-end QoS. When Multi-hop Relay is introduced, QoS must be applied to two independent wireless links – the link between the MS and the RS, and the link between the RS and the MRBS. For MAC-based relay, one can envision a cooperative QoS mechanism in which downlink packets which accumulated high latency in the MRBS/RS link are prioritized over other packets on the RS/MS link (and vice versa). However, such a mechanism is bound to be complicated and bandwidth-consuming, and is not included in 802.16j MAC-based relay. Having abandoned cooperative QoS, the multi-hop QoS problem becomes a problem of assigning Service Flows individual QoS parameters for each of the wireless links. For MAC-based relay, this can be done by observing the CID in each PDU and associating each CID/SF with QoS parameters over the RS/MRBS link. For network-based relay, the CID is not available but the SF can be deduced from the GRE tunnel used to transport the data path. In this sense, MAC-based relay and network-based provide equivalent end to end QoS.

802.16j MAC-based relay also defines Tunnel CIDs (T-CIDs). A T-CID is a connection which traverses all the hops between a RS and the MRBS (See 6.5.3.3). Several user-facing Service Flows are aggregated into a single T-CID, and this single T-CID has a set QoS parameters. Resources for the T-CID are scheduled as if it was a single connection with given QoS parameters, ignoring the individual SFs. Aggregating SFs into a T-CID simplified scheduling and can reduce bandwidth requirements. For example, several MAC PDUs which have a 32-bit CRC each, can be combined to a single Relay MAC PDU which only has a single 32-bit CRC. This mechanism of tunneling different SFs in a single connection can be used for network-based relay easily, though not as efficiently.

### 4.4 Radio Resource Management (RRM) and relay

Radio Resource Management (RRM) is the control of MSs and BSs aimed to increase the bandwidth capacity of the complete network. The two primary tools used for RRM are: *Power Control* – lowering the power used by transmitter to reduce interference to receivers *Handoffs* – changing the BS with which a station communicates in a way which would allow lower transmit power (and less interference). For example, A MS can be handed off from one BS to another if the MS significantly approaches the target BS, so the signal loss between the MS and the target BS is lower, in comparison to the original BS. Additionally, a MS might be handed off from a “crowded” BS to a less utilized BS. This way, the under-utilized BS becomes more utilized, thus wasting less spectrum. The over-utilized BS now has room for new subscribers, and until they arrive, it can either increase bandwidth allocation for the remaining subscribers, or use more robust modulations to reduce transmit power. When relay stations are introduced to the network, RRM is affected in several aspects. First, the new RSs fill the airwaves as if they were BSs: They cause interferences to MSs trying to reach

other RSs or BSs. In this aspect, deploying a RS is similar to deploying a BS (or a Pico- BS). Once can assume that the mechanism used to control inter-BS interferences can be used to control interferences between RSs and BSs.

The second aspect in which relay complicate RRM is the fact that each relayed MS now takes part in more than a single wireless link, and RRM aims to optimize all of them simultaneously. Refer to Figure 35 and consider that the MS can reach both RS A2 and B1 equally well. Deciding which RS will serve the MS is a function of load over the various air interfaces. Which RS is better suited to handle the MS depends on how many subscribers and how much traffic is relayed not only thorough A2 and B1 (as would have been for the non-relay case), but also through the MRBSs A and B and RSs A1 and B2. For example, if there is a high traffic demand from MSs attached to A1, and little demand from other MSs. If the demand is high enough, then the air interface used by MRBS A to provide the backhaul becomes highly utilized. In this case, moving the MS to RS B1 is preferred as it can use the under-utilized air interface of MRBS B. It is therefore clear that in order to have effective RRM, handover decision-making must take into account the load on relevant backhaul links.

The third aspect in which relay affects RRM is the introduction of Mobile RS (MRS). An MRS is a RS which can change its super-ordinate MRBS, e.g., a RS mounted inside a train, providing access to passengers. In terms of mobility, MRS largely functions as a MS. An efficient network should take into account the special requirements of MRS when considering MRS handoffs. The WiMAX networking architecture defines two Profiles. Profile A defines distributed RRM, in which every BS has a Radio Resource Agent (RRA) which collects radio utilization and interference metrics, and a Radio Resource Controller (RRC) which communicates with the RRA and with other RRCs to initiate handovers. Profile C defines the RRC to reside in the ASN-GW. In Profile C, the RRC polls (RRAs) inside every BS to decide when a handover is needed. When using network-based relay, each RS is in essence a BS, together with an RRA and possibly an RRC. If, for the initial stages of deployment, traffic demands are moderate, then using the existing WiMAX RRM, which does not take into account the load over the backhaul links, with little or no modifications, is probably sufficient for the initial stages of deployment. Building RRM for an optimal network can be delayed to when the network is more mature. When using MAC-based relay, a RS does not inherently have RRM capabilities. It is therefore mandatory to implement RRM for the RS in the MRBS.

## 5. Multi-hop Relay Scenarios

A RS can be adapted at several mobility levels, i.e. fixed, nomadic, mobile, and can be used in the Next Generation Networks for improving the communication quality by several aspects, depending on the user needs and the environment conditions and constraints. In this section, the most common relay scenarios are described.

### 5.1 Hole filler

A RS can be used inside the service area of the cell in order to improve link quality to those specific areas that do not have sufficient link quality due to excessive link attenuation from the BS. This attenuation can be caused among other factors due to shadowing of buildings or due to a given hilly topography. Such a scenario is shown in Fig. 6.

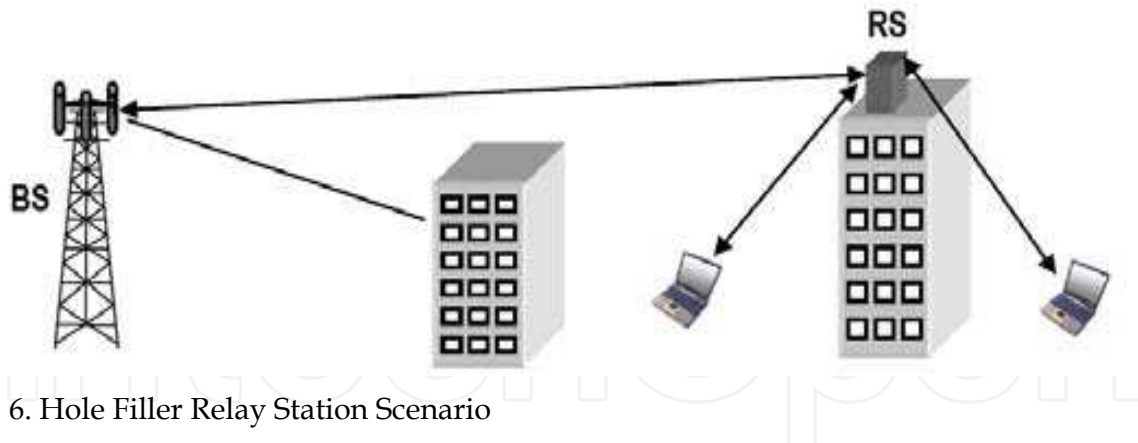

Fig. 6. Hole Filler Relay Station Scenario

### 5.2 Cell extension

In this case, a RS is used to increase the coverage area of a cell. A RS can extend the coverage area in a certain location at the edge of the cell as shown in Fig. 7a or cover an area separated from the coverage area of the cell as shown in Fig. 7b. This latter configuration is sometimes called "remote sector". Cell extension can be used in a more strategic manner where multiple RSs are deployed around the perimeter of a cell to achieve higher coverage area with a single BS, as shown in Fig. 7c. This concept may be used as a part of the network design strategy in order to provide coverage with as few as possible base stations.

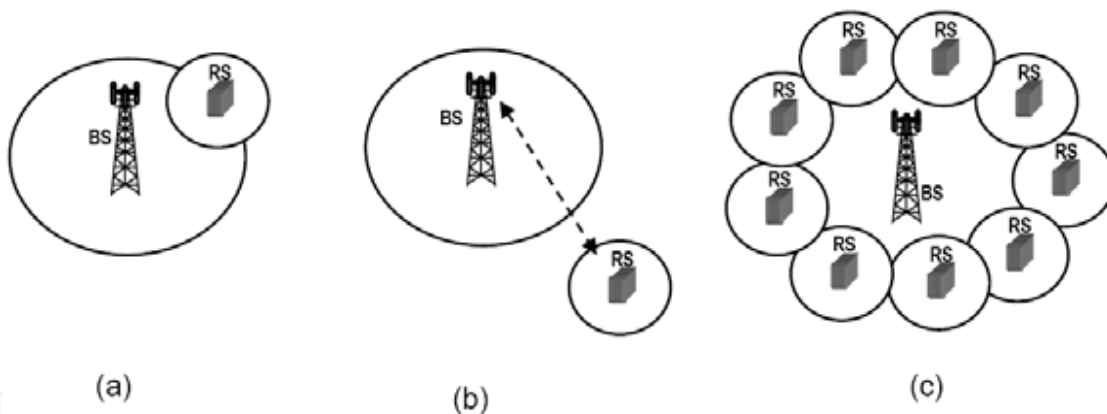

Fig. 7. Cell Extension Relay Station Scenario

### 5.3 Capacity and throughput

In most scenarios, the use of an RS can increase the per-MS throughput, system capacity and QoS. A single link between the BS and RS with high Signal to Interference plus Noise Ratio (SINR) (and as a result with high order modulation and coding scheme) can be replaced with multiple RS to BS links with low SINR. The result is an increase in spectral efficiency which produces a capacity increase. This additional capacity can be used for providing higher throughput to individual MSs or to support more MSs within the coverage area of the RS. In addition, the link reliability is enhanced due to improved SINR. Fig. 8 depicts a scenario where four RSs are deployed in the service area of a sector. The capacity of the original coverage area may increase by a factor of four due to the fact that each RS provides its own capacity to the area and MSs which had low quality link to the BS may have better

link quality to the serving RS. This increase in link quality is translated by the inherent link adaptation process to higher throughput and therefore to a higher capacity.

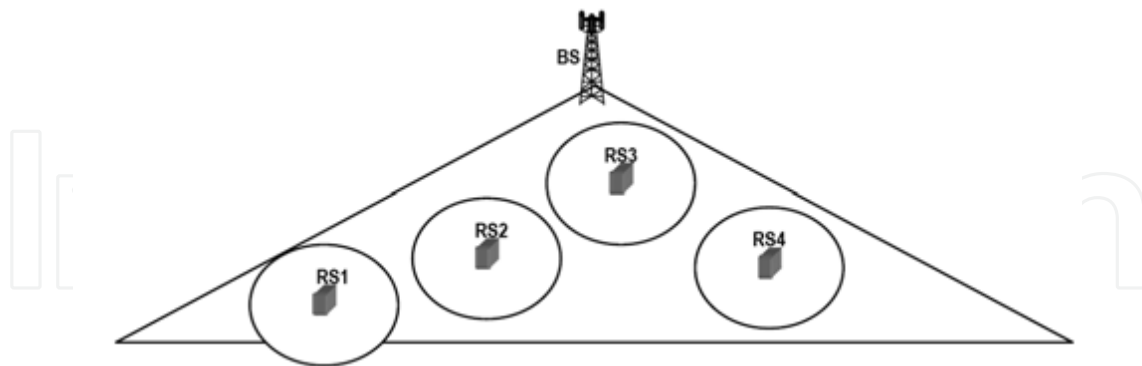

Fig. 8. Capacity and Throughput Improvement Relay Station Scenario

#### 5.4 Indoor usage scenarios

The majority of cellular traffic is generated from buildings. Providing service to indoor MSs by the same BS that provides service to outdoor MSs has several major disadvantages. First, due to the building walls introduced attenuation, BS-MS link might be marginal or of a low quality thus limiting the data rate and consuming excessive time-frequency resource from the BS. MSs which reside in high floors of a building, pose another issue. They are exposed to multiple BSs arriving signals and as a result, two problems may occur: First, signals may interfere with each other, hence degrading the SINR of the MS. Second, MS may enter into an undesired hand off process and as a result, excessive handover processes might occur. This may result in power consumption of the radio, backhaul and computational resources. Relaying technologies in indoor environments can be proved challenging in order to improve the communication. The major methods used for providing dedicated coverage for indoor MSs are described below.

##### 5.4.1 Fixed and nomadic RS with direct connection to the BS

A fixed RS is mounted in a way that its antenna maintains good link quality concurrently with the BS and with the MSs which reside in the building. Alternatively, the RS may be lightweight, nomadic, and similar to a WiFi router.

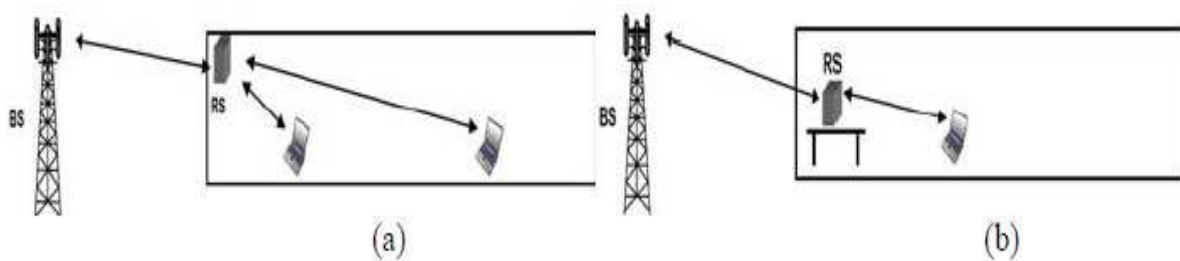

Fig. 9. A Relay Station with direct connection to the Base Station in an indoor scenario. In (a) the Relay Station is Fixed, while in (b) the Relay Station is Nomadic.

### 5.4.2 Multi-hop RS

When large area floors need to be covered, a single RS may not be sufficient. In such cases, multiple RSs can be distributed over the floor connected to each other using the multi-hop capability. The internal RSs can be chained to a RS mounted at the edge of the floor with a good link to the BS as depicted in Fig. 10.

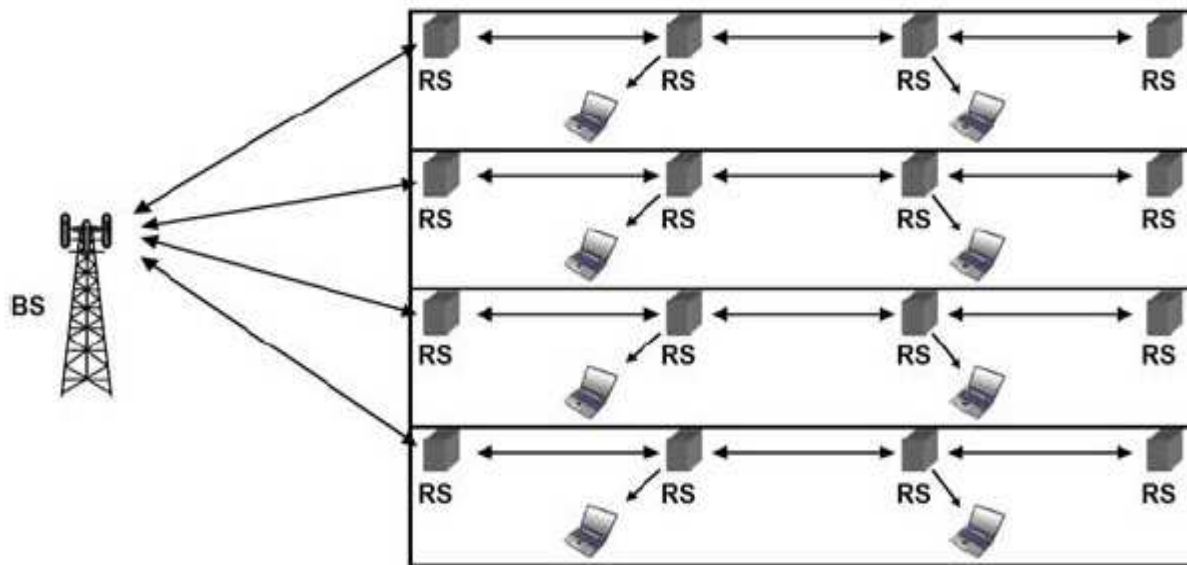

Fig. 10. A Multi-hop Relay Station indoor scenario.

### 5.4.3 Coverage with dedicated external RSs

In some cases it may be possible to provide in-building coverage with external RSs "illuminating" the building from outside as depicted in Fig. 11. The advantage of this model is the elimination of the excruciating need for installing equipment and cabling inside the building.

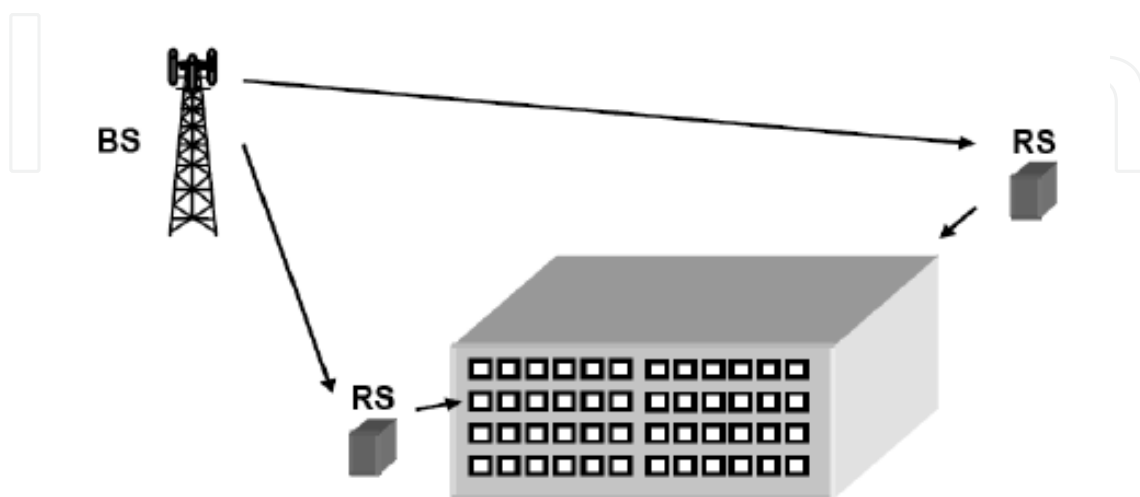

Fig. 11. Two external Relay Stations illuminating a building.

### 5.5 Road and tunnel

The common requirement for roads and tunnels is the need to provide coverage along a linear path. Since high mobility MSs are served, it is recommended to allow the move without handover between the coverage area of each RS. Fig. 12 depicts a scenario where a BS feeds in parallel three transparent RSs. This configuration allows continues high SINR connection along the road without handover.

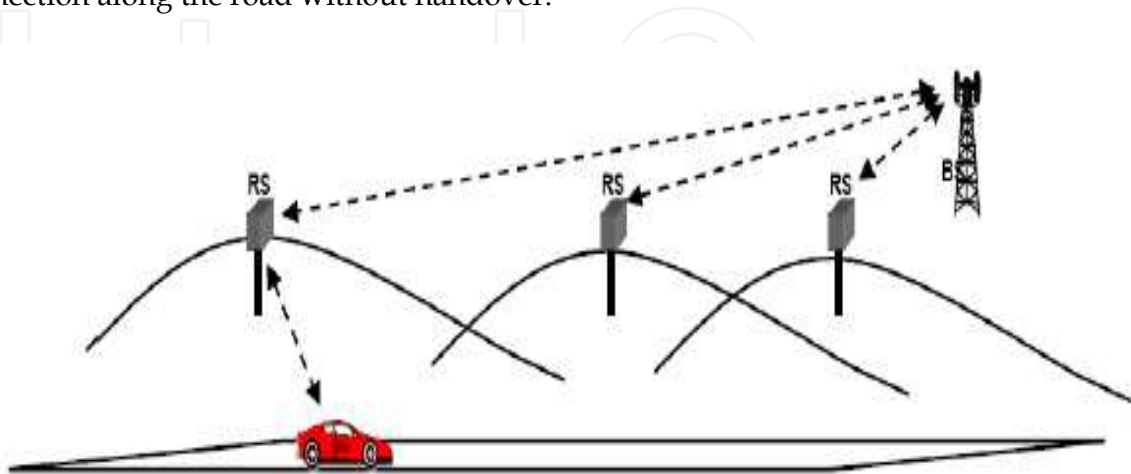

Fig. 12. A Base Station feeds three Relay Stations in parallel.

Fig. 13 shows a tunnel covered by RSs. The RSs inside the tunnel have no connection with the external BSs and therefore multi-hop RSs must be used. In order to minimize the number of hops, the internal RSs can be split to two groups each fed from a BS at each side of the tunnel.

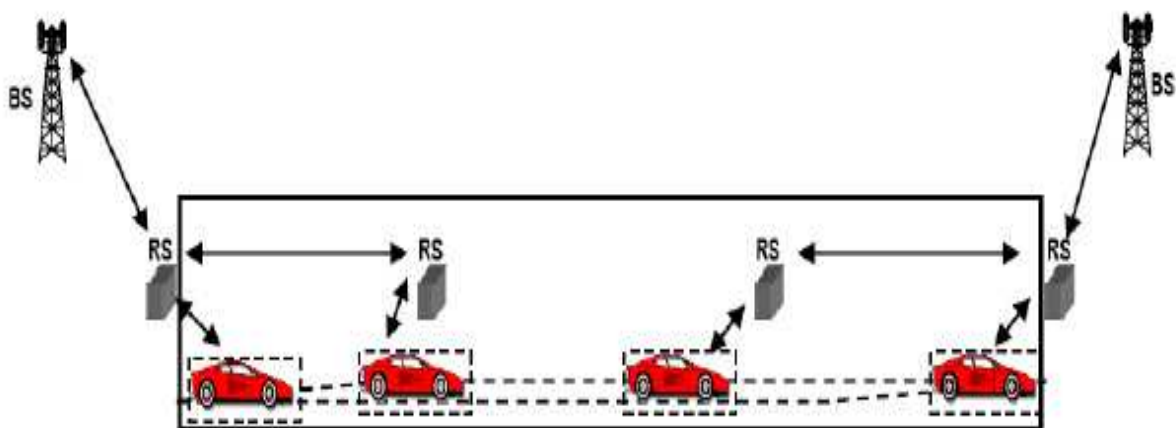

Fig. 13. A tunnel coverage through a multi-hop Relay Station configuration.

### 5.6 Temporary relay stations

RSs may be deployed temporarily to provide coverage or additional capacity. An example would be in events where a heavy load on the network is expected only in certain predefined time interval such as sporting events, concerts or other events where a large crowd is expected to gather. In the case of adding capacity to an area where an event takes

place, usually reasonable coverage from the macro BS already exist. In another usage model a relay can be used for providing coverage in areas where network coverage is needed temporarily for an incidental reason. An example would be an emergency incident or a disaster recovery effort where fixed infrastructure network has been destroyed overloaded or never existed before. Service to those cases can be provided by a deployment of temporary RS usually suitably installed on a vehicle.

## 6. Field tests of the REWIND prototype system

REWIND project examines backhaul-less relay station implementations for WiMAX and supports the relevant standardisation process with interoperability, lab and field information on possible implementations of the WiMAX relay. The main scientific and technological objectives of the REWIND project are in the area of design, development and integration of advanced wireless relay stations based on OFDM technology, in order to foster and exemplify the WiMAX technology by delivering to the subscriber broadband multimedia content. It aims to increase the bandwidth and quality of service to the end users. REWIND prototype system brings a new and promising technology of using WiMAX Relay stations at certain areas that are facing significant performance problems. Performance and coverage tests for both MRBS and RS systems are described below. Two topologies were tested in terms of coverage (with or without MIMO functionality enabled) and total throughput the system can achieve.

### 6.1 System and measurements equipment

Fig. 14 illustrates the multi-hop relay base station (MRBS), the relay station (RS) system and a van on which the mobile station (MS) was installed and has been used for the field measurements.



Fig. 14. MRBS Antenna, transceiver, GPS-RS system-MS.



## 6.2 Topologies

The topologies that were used are shown in the following figures. Fig. 15 illustrates the network topology when a mobile station (MS) is directly connected to the MRBS (one hop), while Fig. 16 shows the network topology where the MS is connected to MRBS via RS (two hops topology).

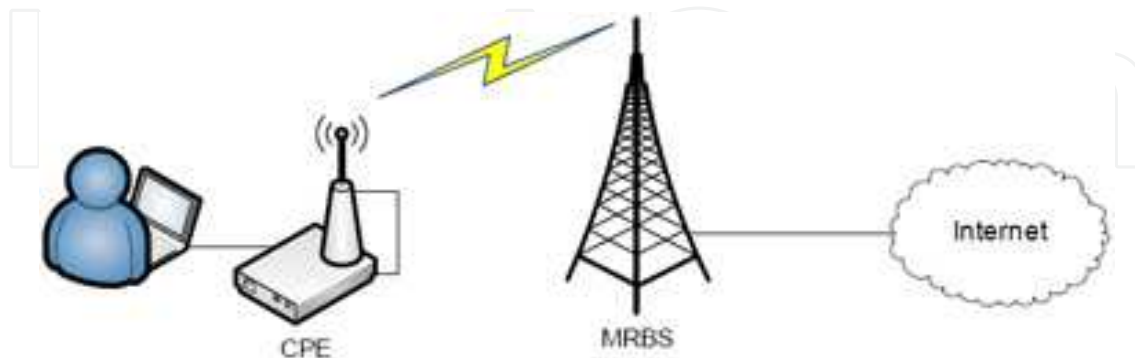

Fig. 15. Topology with MRBS active only.

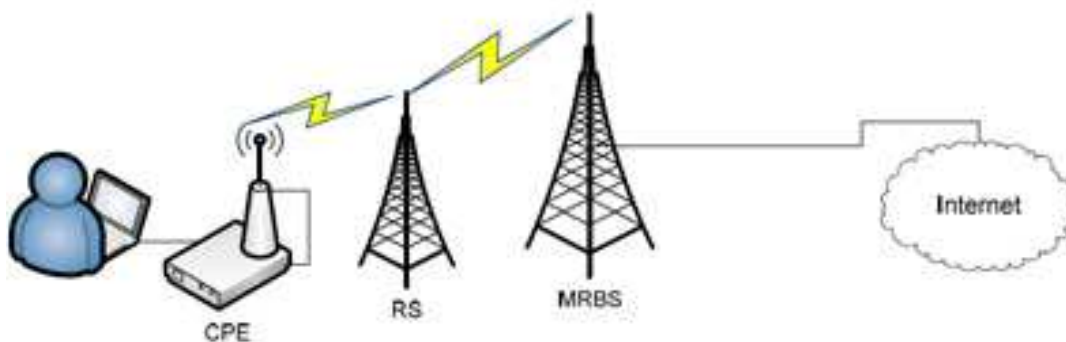

Fig. 16. Two hops topology.

## 6.3 Performance and coverage tests

In order to test the MRBS coverage area the following procedure was followed: An MS that was registered at MRBS, was placed at the roof of a van. The van started moving towards the cell boundary keeping the connection between the MS and the MRBS. The cell coverage of MRBS was the area that covered till the connection was cut off. The maximum distance where the connectivity of the CPE with the MRBS was alive, was at 440m. The same procedure was followed in order to define the coverage area with the RS as well. The results have shown that the usage of the RS extends the cell range to 570m by fully supporting all the QoS levels of 802.16j standard.

The use of MIMO was also tested, in order to clarify and evaluate the communication performance improvement for the MRBS. MIMO antenna technique was expected to improve throughput measurements in both nLOS/LOS conditions. Initially, MIMO was enabled at the MRBS and a van with a mobile station which was registered at the MRBS was moving along a predefined path, where measurements were taken at several places. In the next step, the MIMO functionality was disabled at the MRBS and the van followed the same

predefined path, in which several measurements were taken. The obtained results showed that the use of MIMO functionality at the MRBS provided higher throughput values. The same procedure was performed for the MIMO functionality of the RS. The results in this case also showed higher throughput values and better than the ones of the MRBS. So, even in this scenario, the use of the RS provided improved results.

## 7. Conclusions

Relay technology has focused significant attention due to several important and quite identifiable reasons, i.e. simplicity, flexibility, deployment efficiency and cost effectiveness, as relays can permit a faster network rollout. Conformant to the scope of the actual European REWIND Research Project aiming to develop an effective relay station implementation for WiMAX technology, we have discussed several architecture principles and benefits for relay-based networks and we have presented an essential description of the related RS software architecture design (PHY and MAC layers architecture) for the realization of a proper relay node required for the relay station functionality. Our approach was based on the "core concept" of a multi-hop relay network architecture, adopting the IEEE 802.16j standard.

## 8. Acknowledgements

The present work has been performed in the scope of the REWIND ("RElay based WIreless Network and StandarD") European Research Project and has been supported by the Commission of the European Communities - Information Society and Media Directorate General (FP7, ICT-The Network of the Future, Grant Agreement No.216751).

## 9. References

- Chochliouros, I.; Mor, A.; Voudouris, K.; Agapiou, G.; Aloush, A.; Belesioti, M.; Sfakianakis, E. & Tsiakas, P. (2009). A Multi-Hop Relay Station Software Architecture Design, on the Basis of the WiMAX IEEE 802.16j Standard, *Proceedings of VTC 2009 69th IEEE International Conference on Vehicular Technology*, pp. 132-135, Barcelona, Spain, April 26-29, 2009
- Chokhani, S. & Ford, W. (1999). Internet X.509 Public Key Infrastructure: Certificate Policy and Certification Practices Framework. RFC 2527. *Internet Engineering Task Force (IETF)*, Sterling, VA, USA (1999)
- Harmonized Contribution 802.16j (Mobile Multihop Relay) Usage Models, Available from <http://grouper.ieee.org/groups/802/16/relay/ocs/80216j-06-015.pdf>
- IEEE 802.16-2004, IEEE Standard for Local and metropolitan area networks. Part 16: Air Interface for Fixed and Mobile Broadband Wireless Access Systems, Available from <http://standards.ieee.org/getieee802/download/802.16e-2005.pdf>
- Lin, B.; Ho, H.; Xie, L-L & Shen, X. (2007). Optimal relay station placement in IEEE 802.16j networks, *Proceedings of IWCMC'07 International Conference on Wireless Communications and Mobile Computing*, pp. 25-30, Honolulu, Hawaii, USA, March, 2007
- Nakamura, M. (2008). Standardization Activities for Mobile WiMAX. *Fujitsu Journal of Science & Technology Robotic Systems*, Vol.44, No.3, (2008), pp. 285-291

- Okuda, C.; Zhu, C. & Viorel, D. (2008). Multihop Relay Extension for WiMAX Networks - Overview and Benefits of IEEE 802.16j standard. *Fujitsu Journal of Science & Technology Robotic Systems*, Vol.44, No.3, (2008), pp. 292-302
- Voudouris, K.; Chocliouros, I. ; Tsiakas, P. ; Mor, A. ; Agapiou, G. ; Aloush, A. ; Belesioti, M. & Sfakianakis, E. (2009). Developing an Innovative Multihop Relay Station Software Architecture in the scope of the REWIND European Research Program, *Proceedings of MOBILIGHT 2009 1st International Conference on Mobile Lightweight Wireless Systems*, pp. 144-154, Athens, Greece, May 18-20, 2010
- Zeng, H. & Zhu, C. (2008). System-Level Modeling and Performance Evaluation of 802.16j Multi-hop Relay Systems, *Proceedings of IWCMC, Next Generation Mobile Networks Symposium*, pp. 25-30, Crete Island, Greece, August, 2008

IntechOpen

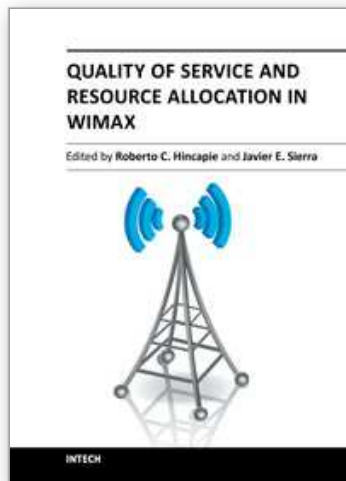

## **Quality of Service and Resource Allocation in WiMAX**

Edited by Dr. Roberto Hincapie

ISBN 978-953-307-956-1

Hard cover, 376 pages

**Publisher** InTech

**Published online** 03, February, 2012

**Published in print edition** February, 2012

This book has been prepared to present state of the art on WiMAX Technology. It has been constructed with the support of many researchers around the world, working on resource allocation, quality of service and WiMAX applications. Such many different works on WiMAX, show the great worldwide importance of WiMAX as a wireless broadband access technology. This book is intended for readers interested in resource allocation and quality of service in wireless environments, which is known to be a complex problem. All chapters include both theoretical and technical information, which provides an in depth review of the most recent advances in the field for engineers and researchers, and other readers interested in WiMAX.

### **How to reference**

In order to correctly reference this scholarly work, feel free to copy and paste the following:

Konstantinos Voudouris, Panagiotis Tsiakas, Nikos Athanasopoulos, Iraklis Georgas, Nikolaos Zotos and Charalampos Stergiopoulos (2012). A WiMAX Network Architecture Based on Multi-Hop Relays, Quality of Service and Resource Allocation in WiMAX, Dr. Roberto Hincapie (Ed.), ISBN: 978-953-307-956-1, InTech, Available from: <http://www.intechopen.com/books/quality-of-service-and-resource-allocation-in-wimax/a-wimax-network-architecture-based-on-multi-hop-relays>

**INTECH**  
open science | open minds

### **InTech Europe**

University Campus STeP Ri  
Slavka Krautzeka 83/A  
51000 Rijeka, Croatia  
Phone: +385 (51) 770 447  
Fax: +385 (51) 686 166  
[www.intechopen.com](http://www.intechopen.com)

### **InTech China**

Unit 405, Office Block, Hotel Equatorial Shanghai  
No.65, Yan An Road (West), Shanghai, 200040, China  
中国上海市延安西路65号上海国际贵都大饭店办公楼405单元  
Phone: +86-21-62489820  
Fax: +86-21-62489821

© 2012 The Author(s). Licensee IntechOpen. This is an open access article distributed under the terms of the [Creative Commons Attribution 3.0 License](#), which permits unrestricted use, distribution, and reproduction in any medium, provided the original work is properly cited.

IntechOpen

IntechOpen