

We are IntechOpen, the world's leading publisher of Open Access books Built by scientists, for scientists

4,800

Open access books available

122,000

International authors and editors

135M

Downloads

Our authors are among the

154

Countries delivered to

TOP 1%

most cited scientists

12.2%

Contributors from top 500 universities

**WEB OF SCIENCE™**Selection of our books indexed in the Book Citation Index
in Web of Science™ Core Collection (BKCI)

Interested in publishing with us?
Contact book.department@intechopen.com

Numbers displayed above are based on latest data collected.

For more information visit www.intechopen.com

Electrooxidation as a Pretreatment Process Before Cyanidation

Fatma Arslan

*Istanbul Technical University, Mining Faculty
Mineral Processing Engineering Department, Istanbul
Turkey*

1. Introduction

The poor extraction of refractory gold ores is an old and still existing problem. Gold losses in cyanidation are mainly due to the presence of sulfide and carbonaceous materials (1,2,3). The decomposition of sulfide minerals during the cyanidation of refractory gold ores creates two types of impurities: metal cations and sulfur compounds (HS^- , $\text{S}_2\text{O}_3^{2-}$, and SO_3^{2-}). The metal cations form complexes with cyanide ion and consume reagent. The sulfide ion is considered to be a powerful poison during the cyanidation and may adsorb on gold, causing the inhibition of gold dissolution reaction by passivation. Sulfur compounds form thiocyanate by consuming cyanide ion and oxygen.

Carbonaceous gold ores contain (a) an activated component which is capable of adsorbing gold complexes from the solution, (b) a mixture of hydrocarbons usually associated with active carbon components (they formed a gold complex during the deposition that was not attacked by cyanide), and (c) an organic acid similar to humic acid, which contains functional groups capable of interacting with gold complexes to form organic gold compounds which might possibly be formed by chelation (1,2,3).

Various procedures had been investigated in an attempt to enhance gold recovery from different ores, including roasting, kerosene treatment, flotation, and aqueous oxidation. If roasting or aqueous oxidation is carried out before cyanidation, the sulfur species tend to oxidize to the less harmful sulfate form. There are several aqueous oxidation techniques prior to cyanidation to treat refractory gold ores: chemical (chlorine, hypochlorite, chlorates, perchlorates, ozone, oxygen, and sulfuric acid) or electrochemical oxidation, pressure leaching, and bacterial leaching.

Oxidation of carbon and sulfide minerals by sodium hypochlorite is a possible method to render the ore amenable to cyanidation, and earlier work by the USBM indicates that electrochemical generation of hypochlorite is promising. An electro-oxidation process was developed by the U.S. Bureau of Mines for generating oxidizing conditions in situ in a pulp prepared from finely ground carbonaceous gold ore and sodium chloride solution (4). Gold extraction by cyanidation after oxidation increased almost in every case compared to that obtained without pretreatment. Electro-oxidation of carbonaceous gold ores, sulfidic gold and silver ores containing pyrite, pyrrhotite, and arsenopyrite has been extensively studied

in a laboratory and pilot scale. There are also several studies carried out on the oxidation of pyrite, pyrrhotite, chalcopyrite, sphalerite, arsenopyrite, gersdorffite (NiAsS) in chlorine saturated water.

Arsenopyritic gold is a major source of refractory gold not amenable to roasting. Bio-oxidation is a popular treatment option but is slow and needs careful control of the As content of the feed. Electrochemical slurry oxidation in-situ with chlorine in acidified salt water can provide a more environmentally friendly process flow-sheet than carbon-in-pulp/leach processing and can be applied to a small or large resource. Chlorine and hypochlorite are not cheap and not fully used in oxidation, electrooxidation process may be alternative and economical to those since all hypochlorite produced in situ are fully used in oxidation.

In order to explain the mechanism of electrooxidation of refractory (carbonaceous and sulfide type) gold ores it is better to understand the production of hypochlorite that is given as follows.

2. Hypochlorite production

Hypochlorite solutions are easy to handle and relatively safe compared to chlorine, but purchased liquid hypochlorite has some disadvantages. Its transportation cost is high due to having concentrations normally range up to 12-15% of available chlorine. Even these concentrations tend to be unstable and decompose easily. A sodium hypochlorite solution generated in situ from readily available salt, on the other hand, is safe and relatively stable (5). Hypochlorite solutions are prepared commercially by electrolyzing a stirred sodium chloride solution. The electrolysis of sodium chloride solutions gives Cl_2 molecules and OH^- ions, and stirring ensures that these species react with each other. The resulting solution is a hypochlorite ion that is a strong reagent (6). Two types of cell design are used to produce hypochlorite, the diaphragm type and non-diaphragm type electrolytic cells.

2.1 Diaphragm type electrolytic cells

Chlorine is produced in an electrolyzer where a diaphragm separates the anodic compartment from the cathodic (7) A solution of sodium chloride flows into the anodic compartment and the reaction at the anode is:



A gaseous chlorine dissolves to some extent in the brine and the following equilibria are established in the diaphragm:



The cathodic reaction is:

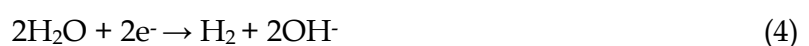

The OH^- ions diffuse into the diaphragm, where they combine with H^+ ions to form water:

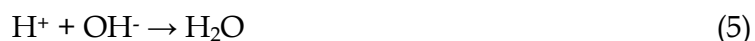

In addition, chemical and electrochemical chlorate formation reactions take place according to the following reactions:

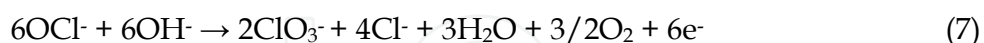
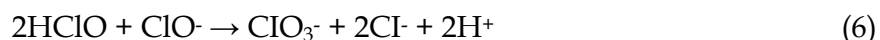

Reactions (3) and (5) proceed much more rapidly than mass transport due to convection and diffusion. Reaction (6) proceeds relatively slowly with respect to those proceedings. The anodic side becomes acidic and the cathodic side is alkaline. The neutralization reaction in the diaphragm results in the formation of salt and water. At low pH, chlorate formation is mainly due to the homogeneous chemical reaction (6), as the electrochemical reaction (7) occurs at high pH (39). Reaction (6) is competitive with the main anodic reaction (1); therefore, it is inefficient with regard to chlorate formation. For chlorate formation according to reaction (6), both pH and temperature controls are important. The stoichiometric ratio of hypochlorous acid to hypochlorite ion required by reaction (3) is achieved by having a pH of about 6 and the rate of reaction increased by about two orders of magnitude by raising the temperature from 20°C to 80°C (8). At elevated temperatures, however, the solubility of chlorine decreases and the amount of undissociated hypochlorous acid escaping from the reactor increased, both of which lead to process inefficiencies. Figure 1 shows the temperature effect on the solubility of chlorine gas (9). The saturation concentration for chlorine is given as 0.06 mole/liter (10).

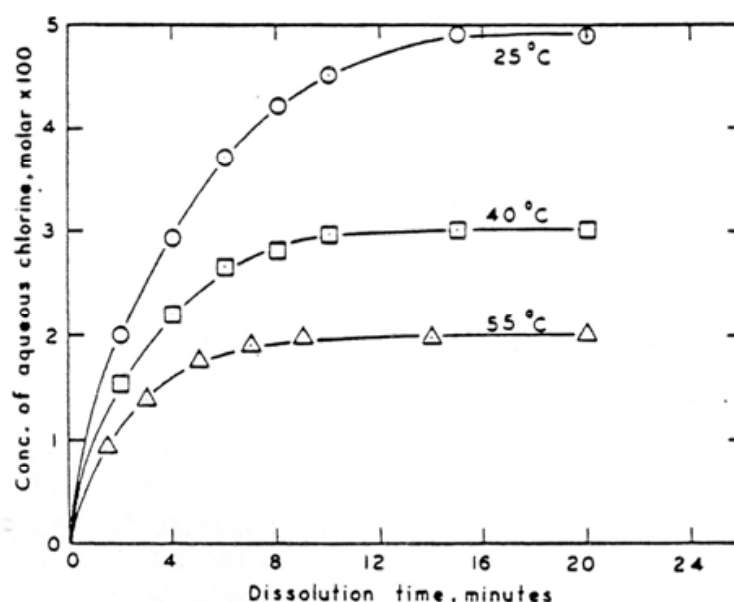

Fig. 1. Temperature effect on the solubility of chlorine gas (9). (Experimental conditions: 0.1 M HCl solution and 400 rpm.)

Cell components, such as electrodes and separators, affect the design and the selection of the best electrolyzer. The design of the anode structure of a diaphragm type chlorine cell using a graphite plate anode used to be limited by the mechanical properties and the machinability of graphite. Gradual degradation during electrolysis was also a problem (11). Therefore,

carbon electrodes were substituted nearly everywhere (chlor-alkali electrolysis, hypochlorite and chlorate productions) by oxide coated Ti and dimensionally stable anodes (DSA), and the coatings are reported to have life times of 3 to 5 years (11). The reasons for using titanium anodes are summarized as follows: (11, 12)

- The excellent stability of titanium against general and pitting corrosion in acidic and slightly basic aqueous solutions.
- Application of RuO_2 coatings or other coatings containing metal oxides or platinum group metals allows the reduction of the over potential for anodic chlorine and anodic oxygen evolution (13). These coatings are particularly stable on a titanium base metal.
- The price of titanium has decreased greatly during the last decade so that costs are no longer prohibitive for a more extensive use of the Ti anode.

Noble metals, in particular Pt metals, are too expensive to be used as bulk materials for electrodes. It is more appropriate to apply them as a coating to a suitable support. Now, because of using metal anodes, cell designs are more flexible. Due to corrosion, the cathodic compartment of a diaphragm type chlorine cell must be fabricated with corrosion resistant materials such as stainless steel (11).

Production of chlorate was studied with a divided laboratory cell equipped with the oxide coated ($\text{RuO}_2\text{-TiO}_2$, Pt-IrO_2 , and PdO) Ti anodes and Pt foil cathode in the respective compartments (14). Figure 2 shows an example of the concentration changes of the chemical species existing in the anolyte as functions of electrolysis time. The concentrations of ClO^- , HClO , and ClO_2^- increased for the first three hours and then became constant. On the other hand, the ClO_3^- concentration increased almost constantly with time after the electrolytic cell reached the steady state. The rates were found to be independent of anode material and are a function of temperature and solution pH. Only the PdO coated anode showed slightly lower values than the others.

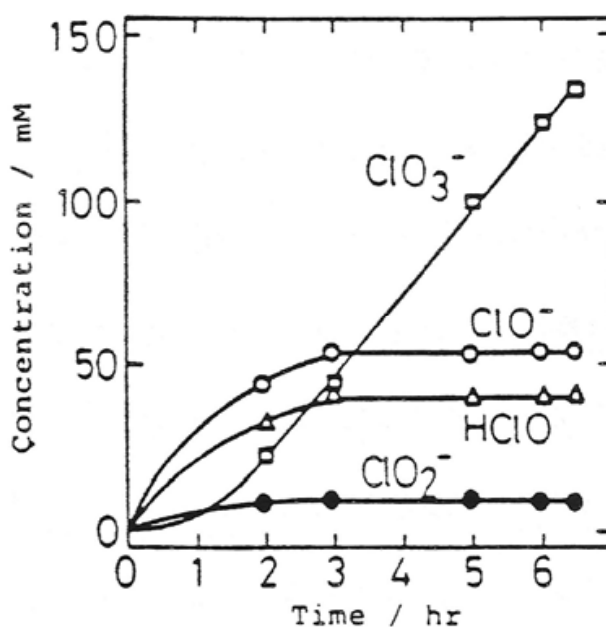

Fig. 2. Solution composition change during electrolysis of NaCl solution (15). (Experimental conditions: 4.0 M NaCl, pH=7.0, T=50°C, E=1.2V vs SCE)

Ibl and Landolt have also studied the anodic chlorate formation in dilute NaCl solutions in a diaphragm type cell using graphite electrodes (10). The diaphragm was porous polyethylene and the solution temperature was $7 \pm 0.5^\circ\text{C}$. Hypochlorite and chlorate concentrations were measured as a function of time and the results are illustrated in Figure 3 (10). In the each run, the change of hypochlorite concentration with time was followed until a steady state with a constant hypochlorite concentration was reached. Concentration profiles near the anode are shown in Figure 4 (10). The hypochlorite concentration increases with the distance from the anode where chlorine concentration shows a decreasing trend.

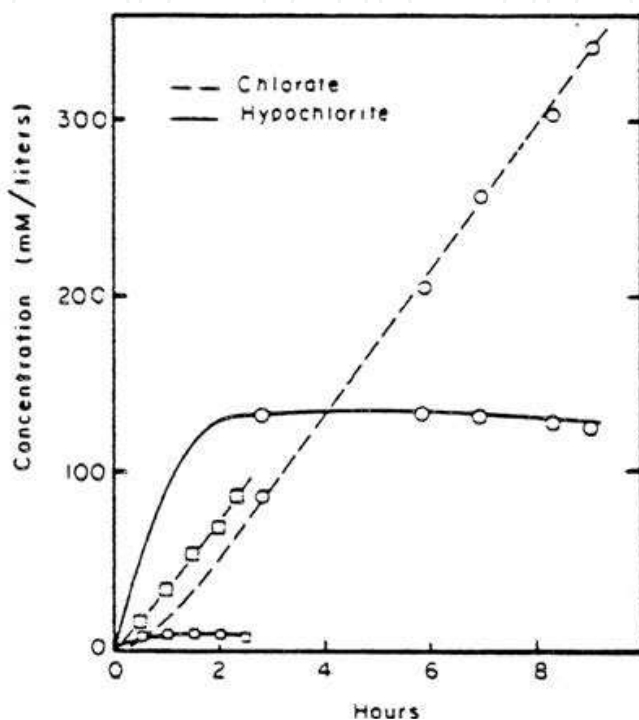

Fig. 3. Variation of hypochlorite and chlorate formation during the electrolysis of NaCl solution (10). (Experimental conditions: \circ 4.0 M NaCl, \square 0.05 M NaCl)

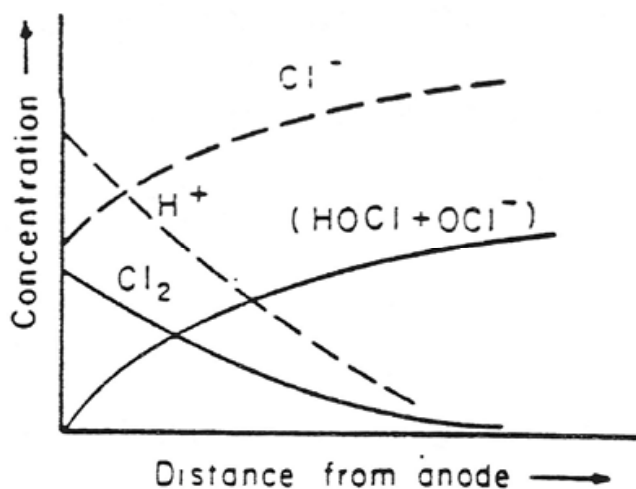

Fig. 4. Schematical representation of concentration profile near anode during the electrolysis of NaCl solution (10).

Separators are another component in the cell design which should be considered. Na^+ , Cl^- , and OH^- are the principal ionic species in the cell (11). The sodium ion is the principal electrolytic current carrier across the separator. Hydroxyl ions also carry some current which reduces the current efficiency of hypochlorite production process. Their transport into anolyte causes chlorate formation with the chlorine and unacceptable losses in reduced chlorine evolution. Therefore, the separator should be designed in such a way that the transportation of the OH^- ions from the catholyte across the anolyte could be prevented. A diaphragm should be operated such that the bulk flow through the pores is sufficient to keep the OH^- ions from migrating across the separator towards the anode in order to prevent reaction (7).

2.2 Non-diaphragm type electrolytic cells

Chemical reactions which occur in this type of cell are summarized in the following. In the electrolysis of NaCl solutions, chlorine is generated at the anode according to the following reaction (5,10):



The chlorine generated immediately undergoes hydrolysis according to the reactions:

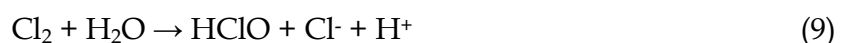

In non-diaphragm hypochlorite cells, solution pH is allowed to range from 7 to 9, insuring complete hydrolysis of the chlorine generated. The pH is balanced by the cathodic evolution of hydrogen as follows:



Equations (8) to (11) describe the ideal behavior of a non-diaphragm hypochlorite cell. There are, however, several competing reactions which contribute to cell inefficiencies. Chlorate may be formed by either anodic oxidation of hypochlorite,

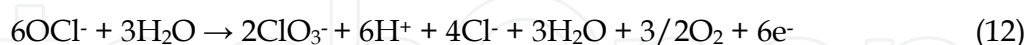

or by the chemical reaction between the hypochlorite ion and hypochlorous acid:



Both of these reactions (12 and 13) have been studied extensively because they are significant in the electrolytic production of chlorate. The chemical chlorate formation, equation (14), proceeds very slowly at room temperature and a basic pH, and when the solution is warmed the disproportionate reaction of hypochlorite occurs rapidly (16). This reaction is, therefore, not significant because cells do not operate over 40°C , and normally equilibrate near pH 9 when making 1 % available chlorine solutions.

Current efficiency may also be lost due to the anodic discharge of hydroxyl ions:



This reaction competes with anodic chlorine evolution. Another reaction which is well documented in the literature (17) because of its importance in chlorate production cells is the cathodic reduction of hypochlorite:

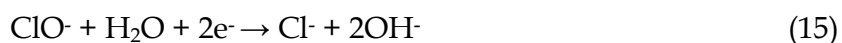

Finally, a small contribution to inefficiency can result from the chemical reaction:



This reaction is normally significant only in the presence of electrolyte impurities such as iron, or in the presence of active catalytic surfaces.

In summary, a non-diaphragm hypochlorite cell functions through equations (8) to (11). Major current efficiency losses result from equations (12), (13), and (14), with minor losses from equations (15) and (16).

In the basic solutions, the following reaction occurs instead of reaction (9) to produce hypochlorite (18):

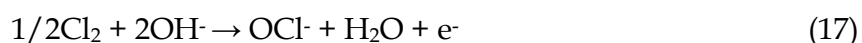

In reaction (8), neither H^+ nor OH^- is involved, so the reduction potential is independent of pH. However, chlorine does not exist in aqueous solution at pH's higher than 5. Hypochlorous acid is a weak acid ($pK_a = 7.4$), and therefore it predominates at any pH below 7.4 and OCl^- is predominant in the basic solutions. The influence of pH on the dissociation of hypochlorous acid is shown in Figure 5 (19).

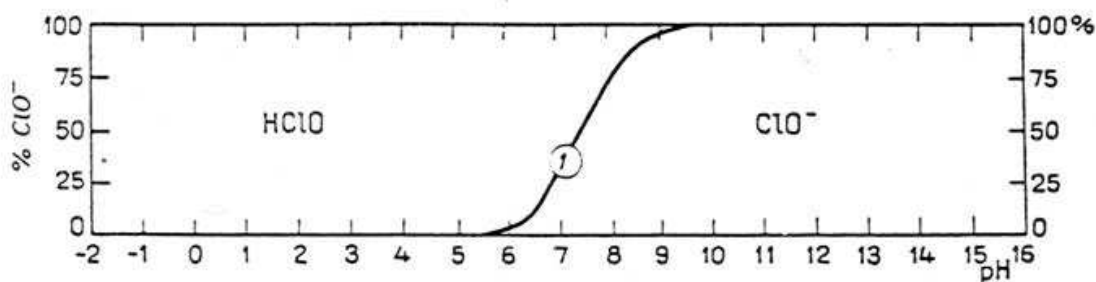

Fig. 5. Effect of pH on the dissociation of hypochlorous acid (19).

ClO_3^- is produced with the electrolysis of hot saturated NaCl solution with the addition of a little dichromate to modify the cathode behavior. Its influence is the formation of a thin diaphragm of insoluble chromium chromate on the cathode which is produced by the reduction of dichromate to chromic ions (20). The diaphragm prevents contact of the bulk of the solution with the electrode and thus with the hydrogen. The electrodes employed were graphite anode and iron cathode (18). In another study, a smooth platinum anode and a wrought iron cathode were used as electrodes (20). If the solution were kept cold and if the electrolysis were stopped at an earlier point, the main product would be hypochlorite.

The relative effects of operating parameters on cell performance were studied by Bennett in batch electrolysis (5). Experiments were performed in a simple compartment cell using DSA anodes (widely used by the chlorine industry), bare titanium cathodes, 1 A/in² current density, and 30 g/l NaCl feed. Anodic current efficiency for producing hypochlorite is found

to be approximately 40%. Of the 60% current efficiency lost, approximately 35% is due to the cathodic reduction of hypochlorite, 10% to the anodic oxidation of hypochlorite, and 15% to the anodic evolution of oxygen from hydroxyl ion. According to these results, current density had a significant effect on the hypochlorite production. When 0.5 A/in² current density was used, anodic current efficiency was near zero due to the sharp increase in the tendency for the cathodic reduction of hypochlorites. Later, a multi-stage cell with continuous flow was developed. Hypochlorite production was gradually increased and total current efficiency in this case could be near 65%, or 25% higher than that for a single compartment.

At lower concentrations, salt utilization was found to be poor, and at higher concentrations, the loss of current efficiency made the operation economically unattractive. A multi-stage electrolytic hypochlorite cell (SANILAC, developed by Diamond Shamrock Corp.) developed as a result of this study, using DSA anodes, is capable of producing 50 lbs/day of chlorine (5). The cell feed consists of a 3% NaCl solution. At available chlorine concentrations of 9.0-9.5 g/l, this cell uses 2.3 to 2.4 kWh(AC) and approximately 3 lb of salt per lb of chlorine. Several sizes of cells producing up to 1000 lb/day of chlorine are commercially available. Similar technology is also being used to produce chlorine economically from seawater.

2.3 Electrooxidation of refractory gold ores

Electrolysis was investigated by the USBM as a means of generating oxidizing conditions in situ in the ore pulp prepared from finely ground carbonaceous ore and NaCl brine (4). This would result in (a) the potential reduction of costs incident to the purchase of hypochlorite and chlorine reagents as compared: (a) the costs of the power and salt, and (b) producing the required oxidant at the desired rate so that excess oxidant would not be consumed by the ore.

The initial research was conducted on the Carlin type carbonaceous gold ores. Later, molybdenum and rhenium reecovery from molybdenite concentrates, and silver and mercury recovery from tailings and Cinnabar ores were studied (21-26).

There are several important parameters in the investigation of electrooxidation, such as salt concentration, electrolysis time, temperature, current density, rate of electrolysis, types of electrodes, electrode spacing, and particle size of the ore.

The effect of salt concentration in the pulp on gold extraction was determined in a series of experiments in which the oxidation time was 7 hours and pulp density was maintained at 40%. Gold extraction increased linearly with respect to NaCl concentration (27). The concentration of salt maintained in the pulp is a principal variable since it affects the conductivity of the pulp and, consequently, the efficiency of hypochlorite production. The use of salt concentration in excess of 200 lb/ton ore resulted in a 95% gold extraction. The corresponding power consumption decreased from 100 kWh/ton ore to 65 kWh/ton ore at the 95% gold extraction range (4).

The effect of temperature on gold extraction was determined at 30, 40, and 50°C. The maximum gold extraction was obtained at 40°C. Generally, the electrode spacing should be as close as is consistent with good pulp flow between the electrodes since the resistance between the electrodes increases with an increase in electrode spacing. Conductivity is a function of pulp density and electrode spacing; and pulp density must be adjusted to give the desired temperature. Generally, the use of lower pulp densities enables the use of closer

electrode spacing, which in turn allows the use of lower salt concentrations. However, this is limited by lower concentrations of the oxidant agent because of slow reaction rates (28).

Current density is another factor which affects the voltage and the temperature. As current density increases, the voltage required also increases. The result of high current density is excessive power consumption and increase of heat input to the system. High current densities also cause undesirable electrode reactions that produce NaClO_3 in the electrolytic cell. According to the results, it was found that a current density of 0.5 to 0.75 A/in^2 of anode surface was acceptable (4).

Grinding is an important part of any hydrometallurgical process because it is necessary to liberate the mineral from the host rock so that the minerals can come in contact with the reactants. Gold extraction increases as the partide size becomes smaller. It was found that 70% -200 mesh was satisfactory for this ore; however, every ore must be evaluated in order to find the optimum partide size for reaction (28).

Several electrode systems were investigated by the USBM (4, 28, 29). The first electrode design utilized was tubular electrodes, as shown in Figure 6. Preliminary experiments with this electrode indicated that considerable resistance to pulp flow was encountered, resulting in a buildup of pulp inside the cathode pipe. The circulation of pulp through this cell was satisfactory during the initial experiments, but with time a deposit of slimes was observed to build up on the cathode, restricting pulp flow.

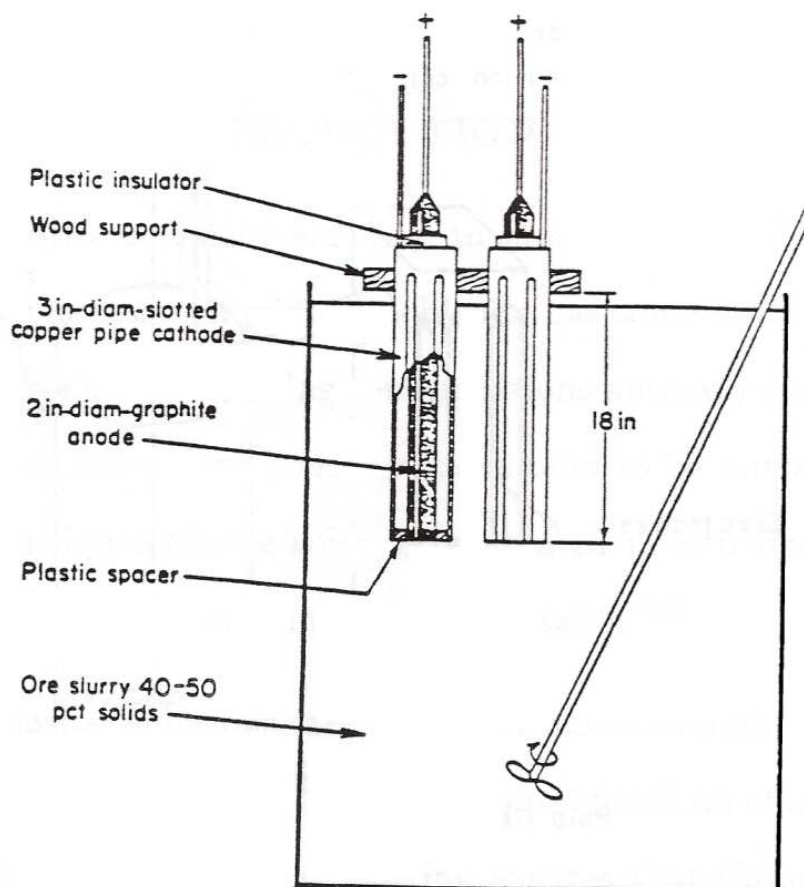

Fig. 6. Tubular type electrode design (from ref. 28)

The second electrode system was a plate-type electrode system consisting of the series of copper cathodes and graphite anodes, as shown in Figure 7. Pulp flow through the electrodes was excellent, but a cathode deposit was still observed to build up with the continued use of the electrode. An alternative arrangement was to substitute graphite for the copper in the plate-type electrodes so that the deposit could be removed by reversing the current. The plate-type arrangement of the cell also offered much less resistance to the pulp flow through the 0.5 inch spacing between the electrodes.

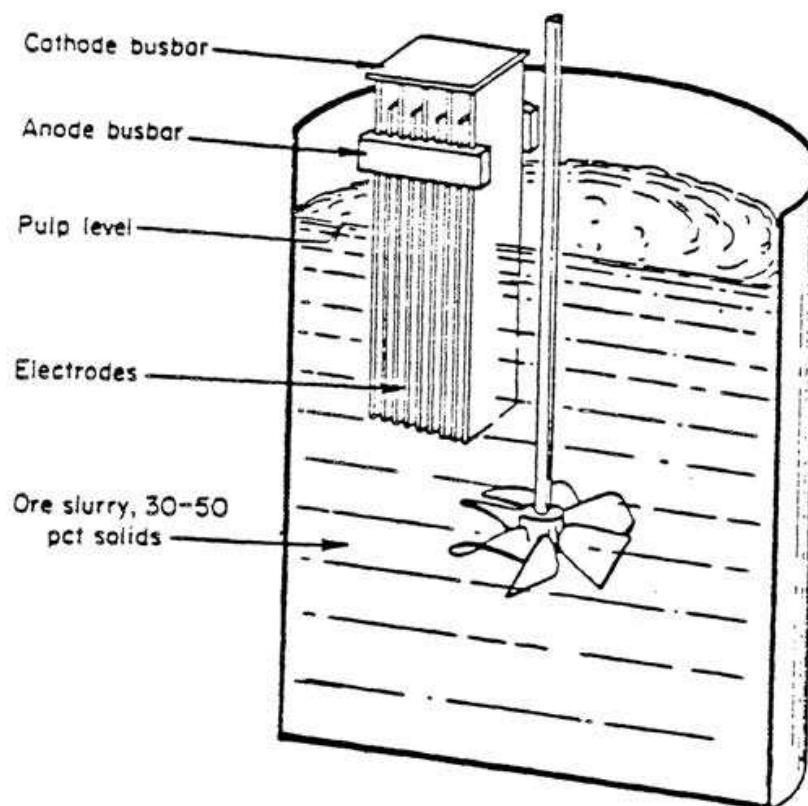

Fig. 7. Plate type electrode design (from ref. 28).

The other electrode design, utilizing a PbO_2 coated titanium anode and an iron cathode, was investigated to determine its effectiveness in generating that required oxidizing conditions at lower salt concentrations. 90% gold extraction by subsequent cyanidation was achieved with 4% salt solution, but because of the lower conductivity of the pulp, an additional 20% power was required.

Some pilot plant studies were also done. The data from the larger scale experiments indicated that scale-up to commercial plants should not present any problems.

In silver and mercury recovery from tailings and Cinnabar ores, the plate-type electrode design which is similar to that used in the treatment of carbonaceous gold ores has been used (21-23).

The bipolar cell design shown in Figure 8 has been used in the recovery of Mo and Re from molybdenite ores (26). The spacing between electrodes was $5/16$ in and the cell consists of ten graphite electrodes held in a plexiglass container. 0.5 A/in^2 was applied. The operating

temperature was maintained at 35-40°C by passing the pulp through water-cooled heat exchangers positioned between the stirred vessel and the cell. The pH was adjusted between 6 and 8. The capacity of the electrolytic oxidation was 1.5 lb/hr of Mo and the concentrate was fed at a rate of between 3.4 and 4.7 lb /h in order to determine the effects of process variables on Mo extraction (26).

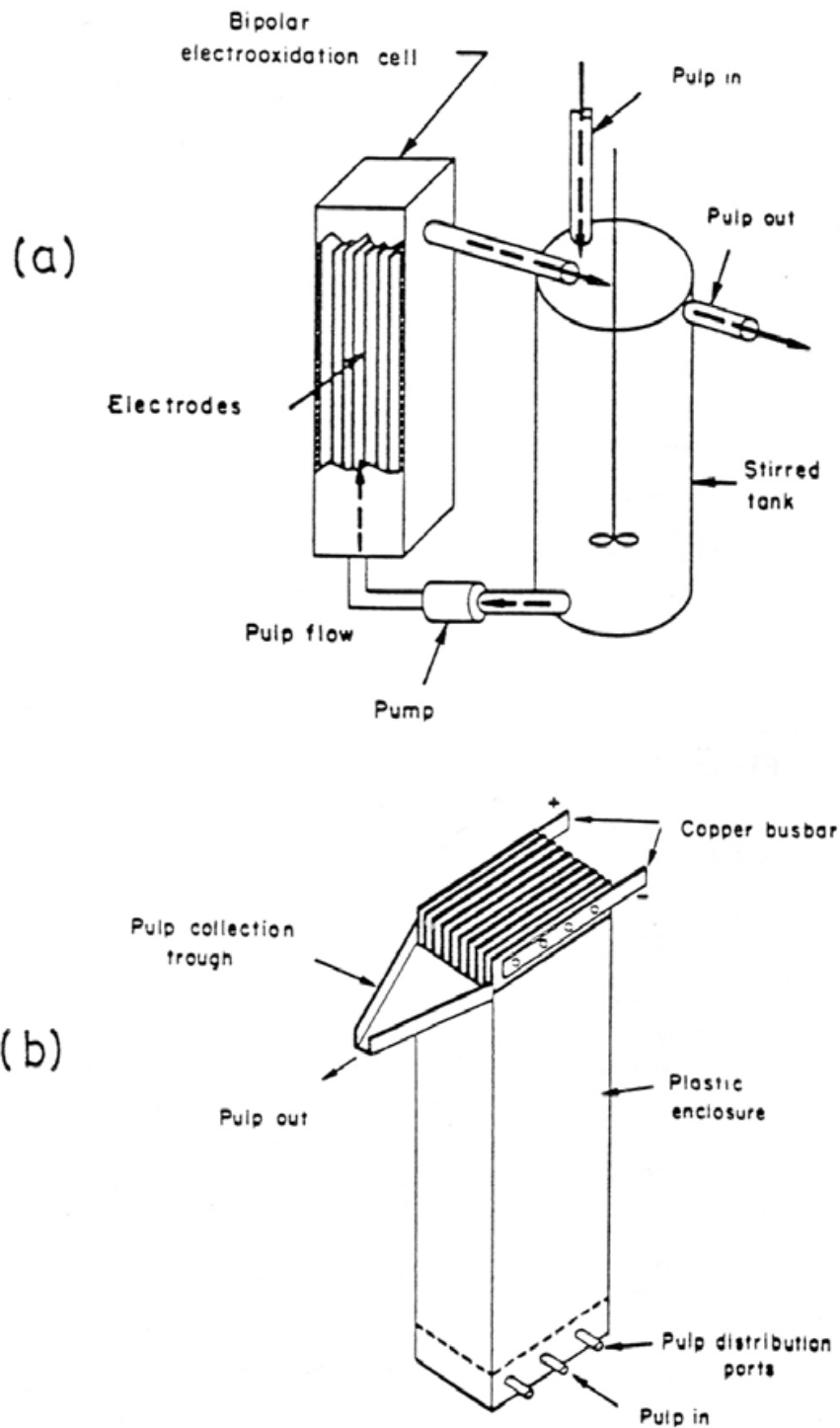

Fig. 8. Pulp flow sequence through agitator and bipolar cell (a), and electrooxidation electrode design (b) (from ref. 26)

Chemical reactions which occur during the electrooxidation can be summarized as follows, (23) the chloride ion is converted to chlorine at the anode:



At the cathode water is hydrolyzed to produce hydroxyl ion and hydrogen:



The reaction between the chlorine and the hydroxyl ion produces hypochlorite according to the following reaction:



Hypochlorite then reacts with the carbonaceous material in the ore, passivating activated carbon:

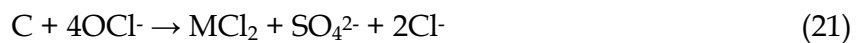

and converting the metal sulfides to chlorides that can hydrolyze to a hydroxide depending the pH of the slurry (30):



The dissolution of the cinnabar can be observed as a two-step process involving oxidation of the sulfide followed by dissolution of sulfate by the chloride ion as shown in the following reactions (23):

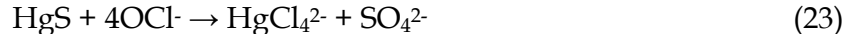

Also, direct oxidation of some of the cinnabar apparently occurs at the anode to produce mercuric sulfate:



The hypochlorite reacts with molybdenite:



The reaction for the oxidation of rhenium with hypochlorite is:



When the technique was used for carbonaceous gold ores, the electrolyte performance was compared with the results obtained by chlorine on the same ore sample (30). The comparison showed that 1.3 to 1.5 kWh of power was required to replace around equivalent of chlorine. At that time, a monopolar cell was used which has the disadvantage of requiring a high amperage rectifier and a large bus bar. In 1978, the cell had been improved, and the new design (a bipolar cell) had overcome the disadvantages. This cell is capable of producing a pound equivalent of chlorine for approximately 1 kWh. Depending on the chlorine prices and the electrical power supply capacity in northeastern Nevada, the electrooxidation technique may provide an economical treatment for carbonaceous ores.

The mechanism of electrooxidation of carbonaceous and sulfide type ores was investigated by Arslan and Duby (31-34) using the two compartment cell as shown in Figure 9, by separating the anolyte and catholyte parts in NaCl solutions. Laboratory work was carried out on the production of hypochlorite and the oxidation of pyrite in an electrochemical cell with a 10% sodium chloride electrolyte at 35–40°C. The production rate of hypochlorite was higher when the pH was not controlled than when it was maintained at the initial value of about 6.5.

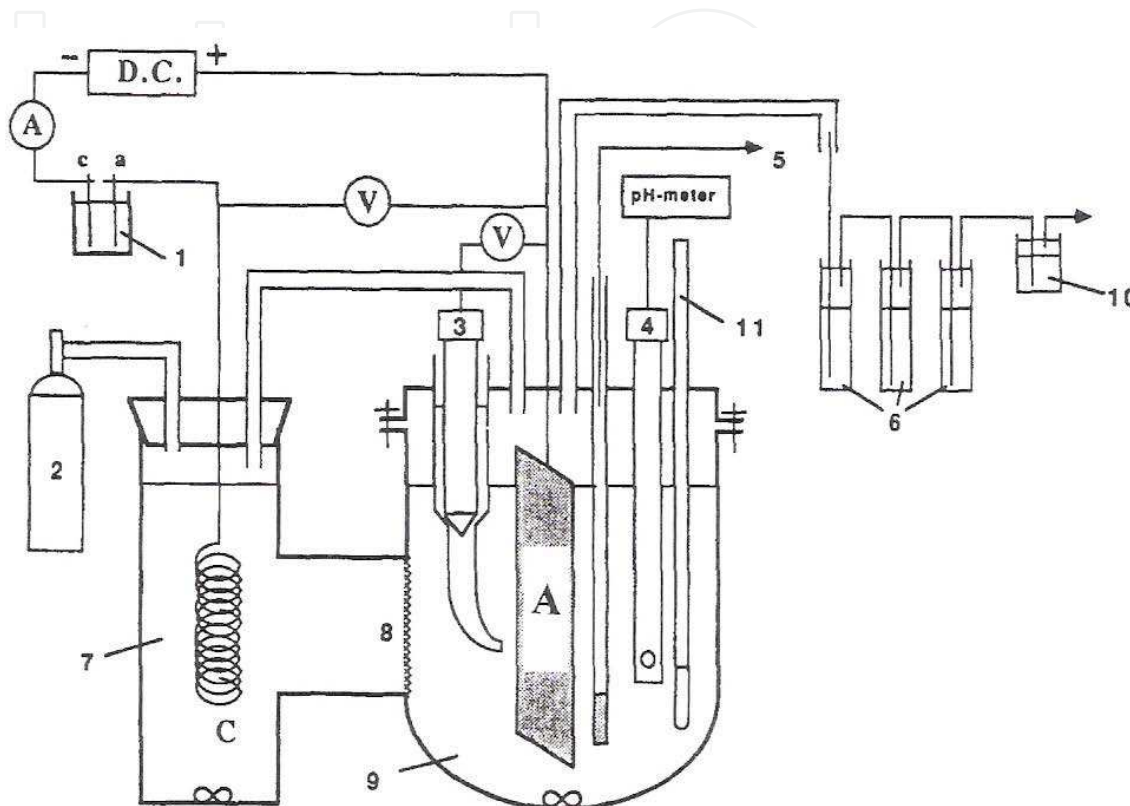

Fig. 9. Experimental arrangement: C=cathode, A=anode, 1=copper coulometer, 2=nitrogen gas tank, 3=saturated calomel electrode, 4=pH electrode, 5=sampling, 6=0.5M NaOH solution, 7=catholyte, 8=glass frit, 9=anolyte, 10=saturated CaO solution, 11=thermometer. (31)

First of all hypochlorite production is studied without any addition of carbon, pyrite or sulfide type gold ore (31,32). Similarly to the early ones, the chemical reactions which occur during the electrolysis of a NaCl solution can be expressed as follows. The chloride ion is converted to chlorine at the anode:



At the cathode, water is hydrolyzed to produce hydroxyl ion and hydrogen:



At the anodic side, hypochlorite is produced according to the following reactions. Chlorine reacts with water to produce hypochlorous acid:

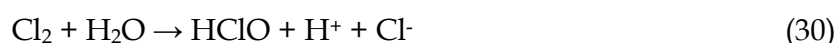

then, the dissociation of hypochlorous acid occurs depending on the solution pH:



and hydroxyl ions produced at the cathode react with hydrogen ions to form water:



After a certain time, hypochlorite production levels off and this is attributed to the production of chlorates, either chemically,



or electrochemically,

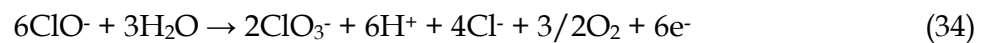

Electrochemical reduction of hypochlorites at the cathode is also possible according to the following reaction:

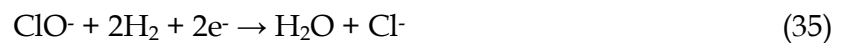

Another reaction is the anodic discharge of hydroxyl ions:



During the experiments the potential and pH measurements are also supported these reactions according to the potential-pH diagrams drawn for the system as hon in Figure 10 and 11. (31)

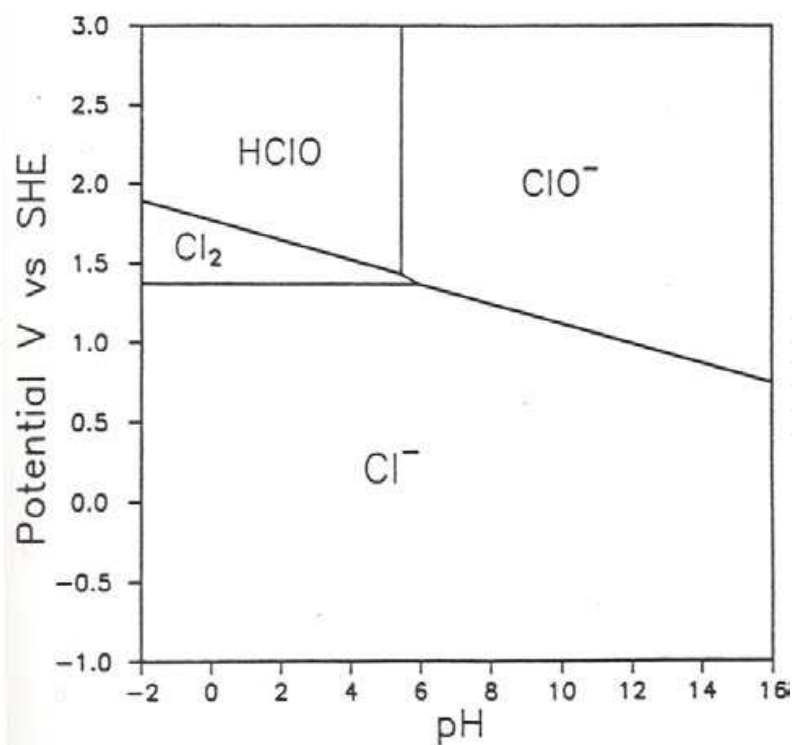

Fig. 10. A potential-pH diagram for the system containing chloride and water at 40°C (stability of hypochlorites). (Chloride concentration is 1.7M). (31)

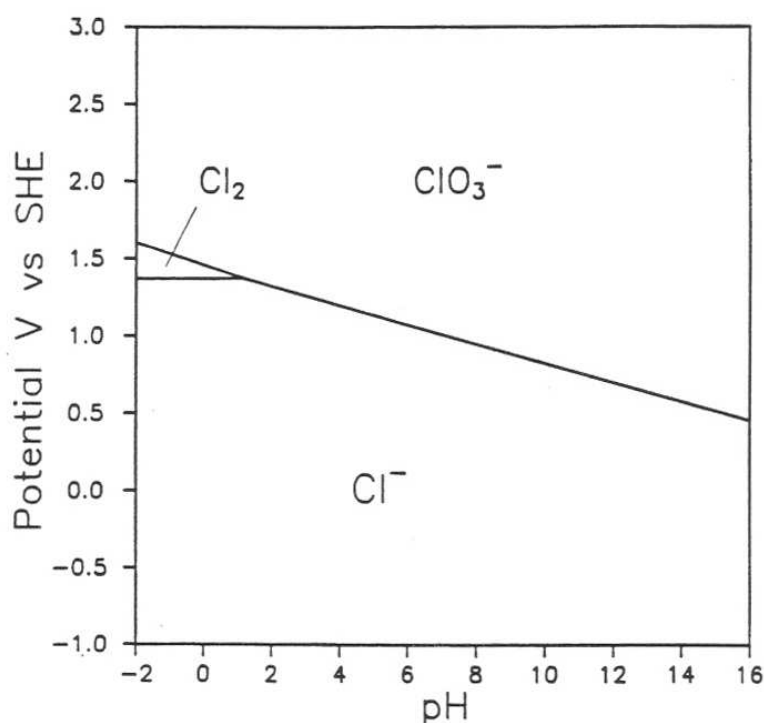
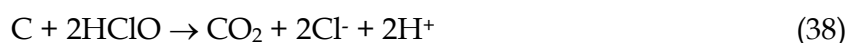

Fig. 11. A potential-pH diagram for the system containing chloride and water at 40°C (stability of chlorates). (Chloride concentration is 1.7M). (31)

During the electrooxidation of carbon, when the graphite anode was used, carbon oxidation was observed but it was difficult to determine the amount of CO_2 attributed to the oxidation of the graphite anode itself (31-32). Therefore, experiments were run using a Pt/Ir coated Ti anode. Carbon is oxidized by hypochlorite which is produced electrochemically in the cell, according to the following equations:



According to the equations (37 and 38) two moles of HClO (or OCl^-) are required for the oxidation of one mole of carbon to CO_2 , corresponding to 4 electrons. Potential and pH measurements taken during the tests were in agreement with those reactions and the potential-pH diagrams of C-Water system shown in Figure 12.

Electrooxidation of pyrite with hypochlorite generated electrochemically in the cell can be expressed as (31,33):

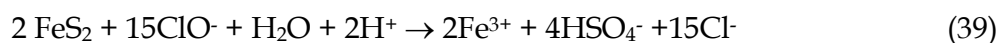

Pyrite oxidation with hypochlorite is a chemical reaction as given in reactions (39 and 40), but the production of chlorine that results in hypochlorite production is an electrochemical process. When the overall process is considered, 7.5 moles of HClO are required per mole of pyrite corresponding to 15 electrons.

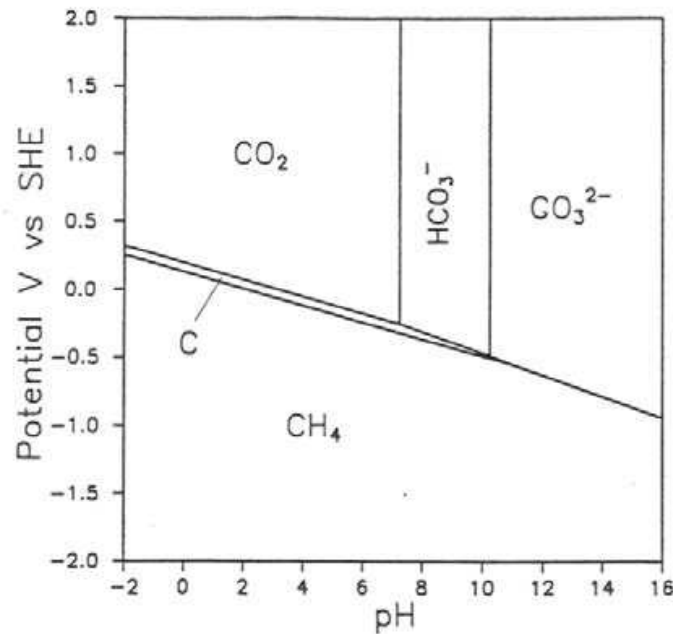

Fig. 12. A potential-pH diagram for the system containing carbon and water at 40°C (for dissolved substances). (Carbon concentration is 0.2M). (31)

Total iron in the solution increased with time at the beginning but leveled off after 4 hours and the current efficiency was about 97%. The oxidation rate was directly related to the current and it was not affected by the pulp density. The solution pH was 1.7 at the end of a 7 hour run. This shows pyrite oxidation according to reaction (40). It was reported in the literature (26) that the oxidation of concentrates high in sulfur or pyrite causes a sharp drop in the pH value as observed in our study. The potential and pH measurements are also agreed with those findings by comparing the results with the potential-pH diagrams given in Figures 12 and 13.

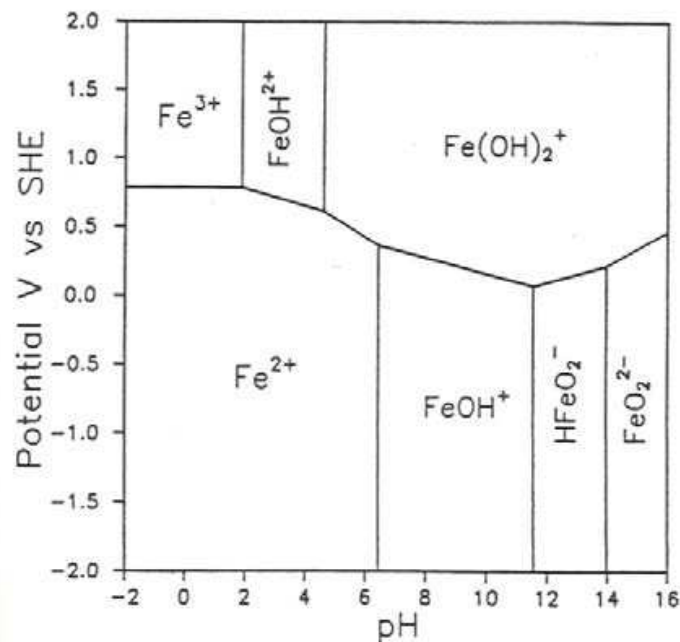

Fig. 13. A potential-pH diagram for the system containing iron and water at 40°C (for dissolved substances). (Iron concentration is 0.05M). (31)

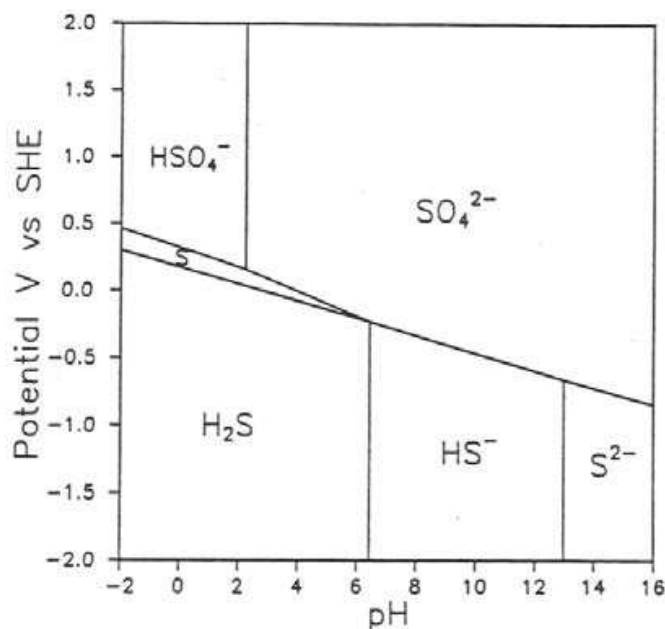
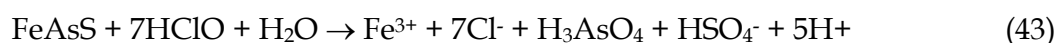

Fig. 14. A potential-pH diagram for the system containing sulfur and water at 40°C (for dissolved substances). (Sulfur concentration is 0.1M). (31)

In tests of electrooxidation of pyritic gold flotation concentrate, stoichiometric calculations show that 23% of total iron in the concentrate is in the form of pyrite, 71% as pyrrhotite, and 6% as arsenopyrite (31, 34). Therefore, the total iron dissolved in the solution may come from these minerals. Pyrite (as given above), pyrrhotite, and arsenopyrite are oxidized according to the following reactions:



According to reactions (41-43), 15 electrons are needed for pyrite oxidation, 9 electrons for pyrrhotite oxidation and 14 electrons for arsenopyrite oxidation. Thus, the weighted average number of electrons is approximately 10.5 and the current efficiencies are calculated by using $n=10.5$ in all cases. At the end of each run the anolyte pH was around 1 and the catholyte pH was about 12. Analysis of anolyte solutions showed no Fe^{2+} , therefore, all iron in the solution was in the form of Fe^{3+} . This agrees with the oxidation reactions given above and can be seen from Figure 14.

Abrantes and Costa is also studied electro-oxidation as a potential alternative process to conventional pre-treatment of a refractory gold ore was investigated. (35) A particulate bed anode of a Portuguese concentrate containing gold was electroleached in a two-compartment electrolytic cell. The effectiveness of the electrochemical treatment is emphasized by comparison with the results of direct leaching under similar conditions. The influence of the operative parameters (e.g., temperature, electrolysis time, current and slurry density) on the overall gold extraction are studied. Up to 90% gold extraction was obtained after electrolytic pre-treatment. A comparison between chemical and electrochemical oxidation using chloride and sulphate solutions was also carried out. The results

demonstrate the better performance of chloride media and that the electrolytic route enhances the amount of precious metal dissolved.

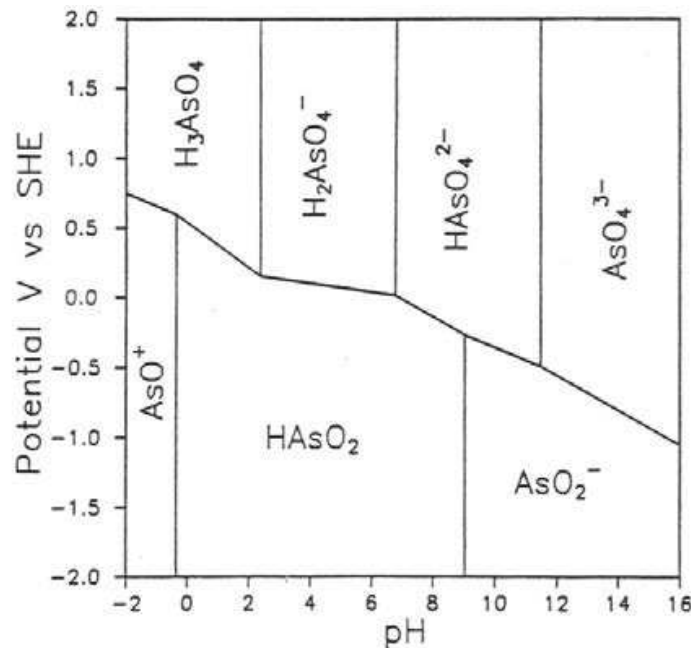

Fig. 15. A potential-pH diagram for the system containing arsenic and water at 40°C (for dissolved substances). (Arsenic concentration is $1.0 \times 10^{-3} \text{M}$). (31)

Since arsenopyritic gold is a major source of refractory gold not amenable to roasting and bio-oxidation is a popular treatment option but is slow and needs careful control of the As content of the feed, H. G. In Linge and N. J. Welham studied, electrochemical slurry oxidation in-situ with chlorine in acidified salt water in a membrane cell reactor has been evaluated at laboratory-scale level as a potential processing route (36). A refractory mine concentrate (cyanideable gold content $\sim 7\%$) containing arsenopyrite (FeAsS), pyrite (FeS_2) and gersdorffite (NiAsS) has been used to demonstrate that gold recovery $> 90\%$ could be achieved. Reaction rates are but sale of the co-produced NaOH can be a valuable process credit. This route can provide a more environmentally friendly process flow-sheet than carbon-in-pulp/leach processing and can be applied to a small or large resource.

The silver mine of the Phoenix Mountain in Guangxi is complicated silver mine with higher arsenic, antimony and copper content (37). The electroleaching of silver is studied and it was found that electrolysis conditions are controlled easy. The recurrence of the process of scaling-up from small to large-size plant is very good, and the silver extraction rate is over 95%.

The electrochemical leaching technology for complex refractory ore was also studied for its high flexibility, easy operation and little pollution (38). It is pointed out that out-field intensification and multifield coupling technology was the development trend for ore processing.

3. References

- [1] Osseo-Asare K., Afenya P.M., and Abotski G.M., "Carbonaceous matter in gold ores: isolation, characterization, and adsorption behavior in aurocyanide solutions",

- Precious Metals: Mining, Extraction, and Processing, Ed. By V. Kudryk, D.A. Corrigan, and W.W. Liang, 1984, TMS Publication, pp. 125-144.
- [2] Guay W.J. and Gross M.A., "The treatment of refractory gold ores containing carbonaceous material and sulfides", The AIME annual meeting, Chicago, Illinois, Feb. 22-26, 1981.
- [3] Demopoulos G.P., "Mineralogical and technological aspects of gold extraction from refractory ores", presented at the Professional Development Seminar in "Mineral Processing of Gold Ores" held at the Dept. of Mining and Metallurgical Eng., McGill Univ., April 30-May 2, 1987.
- [4] Scheiner B.J., Lindstrom R.E., Guay W.J., and Peterson D.G., "Extraction of gold from carbonaceous ores: pilot plant studies", Bureau of Mines RI 7597, 1972.
- [5] Bennett J.E., "Non-diaphragm electrolytic hypochlorite generators", Chemical Engineering Progress, vol 70, no 12, Dec. 1974, pp 60-63.
- [6] Masterton W.I., Slowinski E.J., and Stanitski C.L., Chemical Principles, 5th ed., Saunders College Pub., Philadelphia, 1981, pp 530-533.
- [7] Rousar I., Micka K., and Kimla A., Electrochemical Engineering I, Elsevier Science Pub. Co. Inc., New York, 1986, pp 326-330.
- [8] Pickett D.J., Electrochemical Reactor Design, Elsevier Science Pub. Co. Inc., New York, 1977, pp 362-363.
- [9] Cho E.H., "Coal desulfurization with aqueous chlorine", Met. Trans. B., Oct 1989, vol 20B, pp 567-571.
- [10] Ibl N. and Landolt D., "On the mechanism of anodic chlorate formation in dilute NaCl solutions", J. Electrochem. Soc., vol 115, no 7, July 1968, pp 713-720.
- [11] Ismail M.I., Electrochemical Reactors -Their Science and Technology, Part A, Elsevier Science Pub. Co. Inc., New York, 1989, pp 73-75.
- [12] de Nora V., "From DSA to NCA", proc. of the symp. on Performance of Electrodes for Industrial Electrochemical Processes, vol 89-10, The Electrochem. Soc. Inc., 1989, pp 1-13.
- [13] Muranaga T., Kanaya Y., and Yokota N., "Characteristic of platinum group metal anode for chlor-alkali cells", proc. of the symp. on Performance of Electrodes for Industrial Electrochemical Processes, vol 89-10, The Electrochem. Soc. Inc., 1989, pp 77-86.
- [14] Chemistry of Cyanidation, Mineral Dressing Notes, American Cyanamid Co., AIME annual meeting, New York, Feb. 13-16, 1950.
- [15] Tasaka A. et al., "Activation energy of chlorate production with the oxide coated anodes", proc. of the symp. on Electrochemical Engineering in the Chlor-Alkali and Chlorate Industries, The Electrochem. Soc. Inc., 1988, pp 147-156.
- [16] Segal B.G., Chemistry -Experiment and Theory, John Wiley and Sons Inc., New York, 1985, pp 570-572.
- [17] Wu J., "Kinetics of the reduction of hypochlorite ion", J. Electrochem. Soc., vol 134, no 6, 1987, pp 1462-1467.
- [18] Selly N.J., Experimental Approach to Electrochemistry, John Wiley and Sons Inc., New York, 1977, pp 99-101, 123.
- [19] Pourbaix M., Atlas of Electrochemical Equilibria in Aqueous Solutions, NACE, 1974, pp 591-603.
- [20] Knibbs N.V.S. and Palfreeman H., "The theory of Electrochemical Chlorate and perchlorate formation", Trans. of Faraday Soc., 1920, no 16, pp 402-433.

- [21] Scheiner B.J., Pool D.L., and Lindstrom R.E., "Recovery of silver and mercury from mill tailings by electrooxidation", Bureau of Mines RI 7660, 1972.
- [22] Shedd E.S., Scheiner B.J., and Lindstrom R.E., "Recovery of mercury from cinnabar ores by electrooxidation-extraction plant amenability tests", Bureau of Mines RI 8083, 1975.
- [23] Scheiner B.J., Lindstrom R.E., and Shanks D.E., "Recovery of mercury from cinnabar ores", Bureau of Mines RI 7350, 1973.
- [24] Scheiner B.J., Pool D.L., Lindstrom R.E., and McClelland G.E., "Prototype commercial electrooxidation cell for the recovery of molybdenum and rhenium from molybdenite concentrates", Bureau of Mines RI 8357, 1979.
- [25] Lindstrom R.E. and Scheiner B.J., "Extraction of molybdenum and rhenium from concentrates by electrooxidation", Bureau of Mines RI 7802, 1973.
- [26] Scheiner B.J., Lindstrom R.E., and Pool D.L., "Extraction and recovery of molybdenum and rhenium from molybdenite concentrates by electrooxidation: process demonstration", Bureau of Mines RI 8145, 1976.
- [27] Scheiner B.J., Lindstrom R.E., and Henrie T.A., "Processing refractory carbonaceous ores for gold recovery", *Journal of Metals*, March 1971, pp 37-40.
- [28] Scheiner B.J., Lindstrom R.E., and Henrie T.A., "Oxidation process for improving gold recovery from carbon-bearing gold ores", Bureau of Mines RI 7573, 1971.
- [29] Scheiner B.J., Lindstrom R.E., and Henrie T.A., "Process for recovering gold from carbonaceous ores", U.S. Patent no. 3,574,600, April 13, 1971.
- [30] Scheiner B.J., "Relation of mineralogy to treatment methods for carbonaceous gold ores", The SME annual meeting, Denver, Colorado, Feb. 24-27, 1987.
- [31] F. Arslan, Electrooxidation of refractory gold ores. Ph.D. Thesis, Columbia Univ. (1991).
- [32] F. Arslan, P.F. DUBY, Mechanism Of Electrooxidation Of Refractory Gold Ores, SME, 1991, Preprint Number 91-38 9 pages.
- [33] F. Arslan, P.F. DUBY, Electro-oxidation of pyrite in sodium chloride solutions, *Hydrometallurgy*, Volume 46, Issues 1-2, August 1997, pp 157-169.
- [34] F. Arslan, P.F. DUBY, Electrooxidation of gold-bearing sulfide concentrate, *Minerals & Metallurgical Processing*, Feb 1, 2003. vol. 20, no 1, pp. 10-14.
- [35] L. M. Abrantes and M. C. Costa, Electro-oxidation as a pretreatment for gold recovery, *Hydrometallurgy*, Volume 40, Issues 1-2, January 1996, pp 99-110.
- [36] H. G. Linge and N. J. Welham, Gold recovery from a refractory arsenopyrite (FeAsS) concentrate by in-situ slurry oxidation, *Minerals Engineering*, Volume 10, Issue 6, June 1997, Pages 557-566.
- [37] WANG Wei-xi, LUO Jian-ping, LI Li-jun, Study on Extracting Silver from Silver Concentrate in Guangxi by Slurry Electrolysis Process. *Nonferrous Metals (Extractive Metallurgy)*, 2006-05.
- [38] Z.H. Liu, Y. Li, X.X. Zhou, J. Du, C.Y. Tao, Research Progress of Electro-oxidation of Intensification leaching for Refractory Ore, *Advance Materials Research (volumes 236-238)*, Vol. Application of Chemical Engineering, May 2011, pp 775-780.

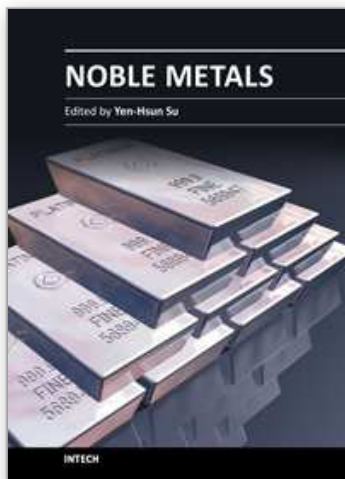

Noble Metals

Edited by Dr. Yen-Hsun Su

ISBN 978-953-307-898-4

Hard cover, 426 pages

Publisher InTech

Published online 01, February, 2012

Published in print edition February, 2012

This book provides a broad spectrum of insights into the optical principle, resource, fabrication, nanoscience, and nanotechnology of noble metal. It also looks at the advanced implementation of noble metal in the field of nanoscale materials, catalysts and biosystem. This book is ideal not only for scientific researchers but also as a reference for professionals in material science, engineering, nonascience and plasmonics.

How to reference

In order to correctly reference this scholarly work, feel free to copy and paste the following:

Fatma Arslan (2012). Electrooxidation as a Pretreatment Process Before Cyanidation, Noble Metals, Dr. Yen-Hsun Su (Ed.), ISBN: 978-953-307-898-4, InTech, Available from: <http://www.intechopen.com/books/noble-metals/electrooxidation-as-a-pretreatment-process-before-cyanidation>

INTECH
open science | open minds

InTech Europe

University Campus STeP Ri
Slavka Krautzeka 83/A
51000 Rijeka, Croatia
Phone: +385 (51) 770 447
Fax: +385 (51) 686 166
www.intechopen.com

InTech China

Unit 405, Office Block, Hotel Equatorial Shanghai
No.65, Yan An Road (West), Shanghai, 200040, China
中国上海市延安西路65号上海国际贵都大饭店办公楼405单元
Phone: +86-21-62489820
Fax: +86-21-62489821

© 2012 The Author(s). Licensee IntechOpen. This is an open access article distributed under the terms of the [Creative Commons Attribution 3.0 License](#), which permits unrestricted use, distribution, and reproduction in any medium, provided the original work is properly cited.

IntechOpen

IntechOpen