

We are IntechOpen, the world's leading publisher of Open Access books Built by scientists, for scientists

4,800

Open access books available

122,000

International authors and editors

135M

Downloads

Our authors are among the

154

Countries delivered to

TOP 1%

most cited scientists

12.2%

Contributors from top 500 universities



WEB OF SCIENCE™

Selection of our books indexed in the Book Citation Index
in Web of Science™ Core Collection (BKCI)

Interested in publishing with us?
Contact book.department@intechopen.com

Numbers displayed above are based on latest data collected.

For more information visit www.intechopen.com



New Olive-Pomace Oil Improved by Hydrothermal Pre-Treatments

G. Rodríguez-Gutiérrez, A. Lama-Muñoz, M.V. Ruiz-Méndez, F. Rubio-Senent and J. Fernández-Bolaños
*Departamento de Biotecnología de los Alimentos,
Instituto de la Grasa (CSIC), Avda, Seville,
Instituto al Campus de Excelencia Internacional Agroalimentario, ceiA3
Spain*

1. Introduction

The health properties of virgin olive oil (VOO) are well known in the Mediterranean Diet, in which VOO is the main source of fat (Boskou, 2000). The Mediterranean area provides 97% of the total olive production of the world and represents a major industry in the region (Aragon & Palancar, 2001). The fatty acid composition is not the only healthy component of olive oil; in addition, minor components have high biological activities (Pérez-Jiménez et al., 2007). From the olive oil by-product, the olive-pomace oil (OPO) is obtained. Recent studies have demonstrated the positive benefits of OPO on health, and these effects are due mainly to the presence of minor components (Ruiz-Gutiérrez et al., 2009). The new olive oil extraction processes in the olive mills make the extraction of OPO and the general utilisation of wastes more difficult. New thermal systems are proposed to pre-treat the olive oil wastes to facilitate their utilisation and OPO extraction.

1.1 Olive oil extraction systems

The manufacturing process of olive oil has undergone evolutionary changes. The traditional discontinuous pressing process was initially replaced by continuous centrifugation, using a three-phase system and later a two-phase system. Depending on the different olive oil production method, there are different kinds of wastes. The classic production of olive oil generates three phases and two wastes: olive oil (20 %), solid waste (30 %) and aqueous liquor (50 %). The solid waste (olive cake or “orujo”) is a combination of olive pulp and stones. The aqueous liquor comes from the vegetation water and the soft tissues of the olive fruits, with water added during processing (so-called “alpechin” or “olive-mill waste water”). The presence of large amounts of organic substances (oil, polyphenols, protein, polysaccharides, etc.) and mineral salts represents a significant problem for the treatment of wastewater (Borja et al., 1997).

The use of a modern two-phase processing technique to which no water is added generates oil and a new by-product that is a combination of liquid and solid waste, called “alperujo”, “alpeorujo” or “two-phase olive mill waste”. This by-product is a high-humidity residue

with a thick sludge consistency that contains 80 % of the olive fruit, including skin, seed, pulp and pieces of stones, which is later separated and usually used as solid fuel (Vlyssides et al., 2004). In Spain, over 90 % of olive oil mills use this system, which means that the annual production of this by-product is approximately 2,5-6 million tons, depending on the season (Aragon & Palancar, 2001).

1.2 Utilisation of olive oil wastes

Alperujo presents many environmental problems due to its high organic content and the presence of phytotoxic components that make its use in further bioprocesses difficult (Rodríguez et al., 2007a). Most of these components mainly phenolic compounds, confer bioactive properties, to olive oil. The extraction of the phenolic compounds has a double benefit: the detoxification of wastes and the potential utilisation as functional ingredients in foods or cosmetics, or for pharmacological applications (Rodríguez et al., 2007a). Although olive mill wastes represent a major disposal problem and potentially a severe pollution problem for the industry, they are also a promising source of substances of high value. In the olive fruits, there is a large amount of bioactive compounds, many of them known to have beneficial health properties. During olive oil processing, most of the bioactive compounds remain in the wastes or alperujo (Lesage- Meessen et al., 2001). Therefore, new strategies are needed for the utilisation of this by-product to make possible the bioprocess applications and the phase separation of alperujo.

Until now, efforts focussed on detoxifying these wastes prior to disposal, feeding, or fertilisation/composting, because they are not easy degradable by natural processes, or even used in combustion as biomass or fuel (Vlyssides et al., 2004). However, the recovery of high value compounds or the utilisation of these wastes as raw matter for new products is a particularly attractive way to reuse them, provided that the recovery process is of economic and practical interest. This, added to the alternative proposals to diminish the environmental impact, will allow the placement of the olive market in a highly competitive position, and these wastes should be considered as by-products (Niaounakis & Halvadakis, 2004).

1.3 Olive-pomace oil

After VOO extraction, the residual oil, or crude olive-pomace oil (COPO), is extracted by organic solvent extraction or centrifugation from olive oil wastes. After the COPO refining step, the refined olive-pomace oil (ROPO) is blended with VOO, obtaining OPO for human consumption. Currently, the growing interest in OPO is due to its biological active minor constituents (Ruiz-Gutiérrez et al., 2009). The concentration of these components in OPO is higher than the concentration in VOO, with the exception of polar phenols (Perez-Camino & Cert, 1999). Today, new processes for COPO refining are studied in order to diminish the loss of minor components (Antonopoulos et al., 2006). Some of these components are recovered in the refining steps.

Alperujo is treated by the OPO extractors for crude olive-pomace oil extraction (**Figure 1**). First, the major part of the stone present is removed, with the initial stone concentration of about 45% and, after the stone extraction, less than 15%. The stone is easily commercialised for numerous uses, such as in combustion materials, activated carbon, liquid and gas production from stone pyrolysis, an abrasive for surface preparation or for cosmetics, in

addition to others (Rodríguez et al., 2008). The pitted alperujo is frequently centrifuged in the OPO extractor because the new decanter technology allows treating low-fat material for oil extraction, through which crude olive-pomace oil is obtained. After this mechanical extraction, a partially defatted and pitted alperujo is obtained, with a humidity close to 50%. This material is dried to no more than 10% humidity for both solvent extraction and combustion. Drying consumes much energy, therefore attempts are continuously to reduce energy costs and to avoid the appearance of undesirable compounds in pomace-olive oil formed by the high temperatures (up to 500 °C) such as polycyclic aromatic hydrocarbons (PAHs) (León -Camacho et al., 2003) or oxidised compounds (Gomes and Caponio, 1997).

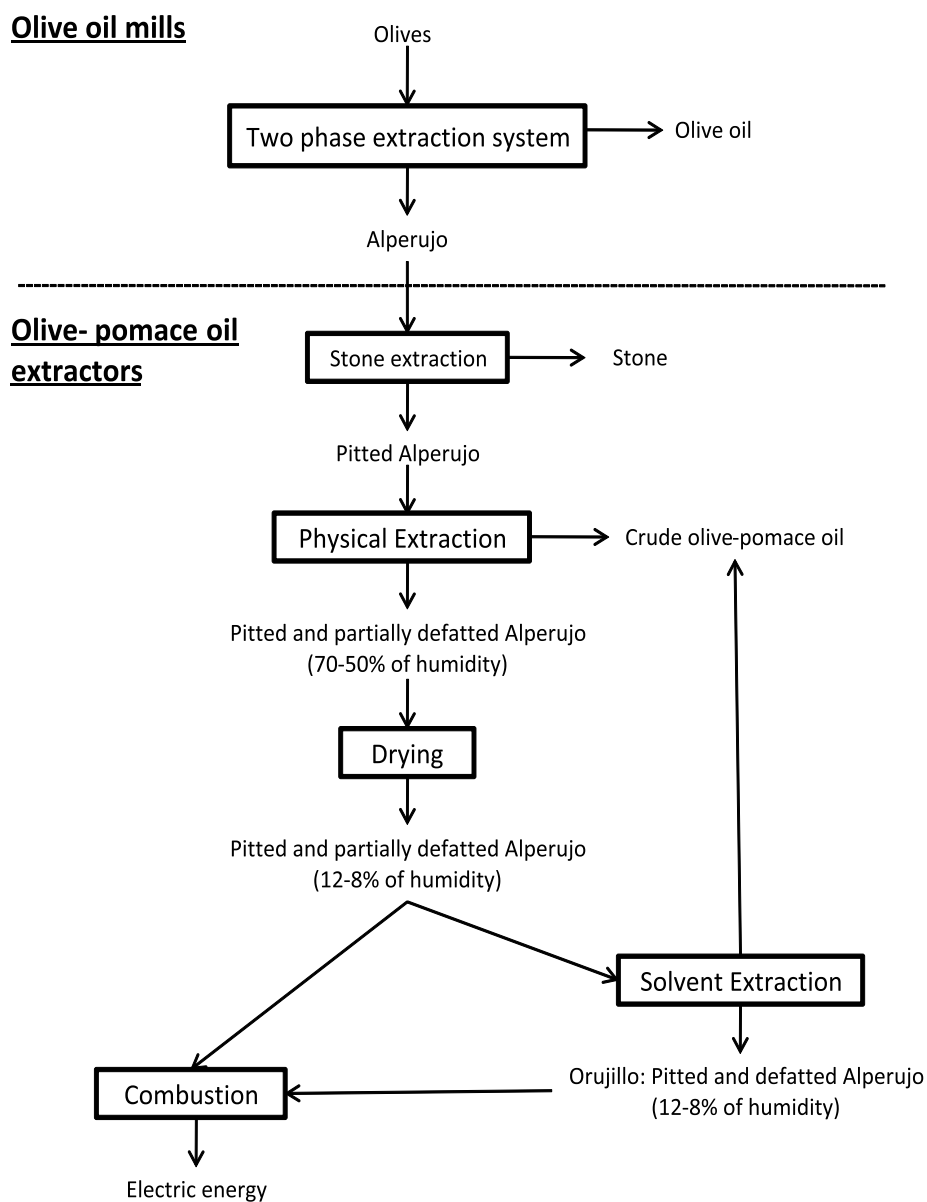

Fig. 1. General scheme of industrial olive oil and olive-pomace oil extraction and by-product processing.

The drying process is usually carried out in rotary heat dryers (Espínola-Lozano, 2003) in which alperujo and hot gases obtained from orujillo, olive stones or exhausted gases from co-generation systems (Sánchez & Ruiz, 2006) are introduced at 400 to 800 °C. The high temperatures have negative effects on the final composition of COPO. After drying, the pitted and partially de-fatted alperujo, with humidity close to 10%, is extracted with organic solvents. After the extraction, the organic solvent is removed for COPO production. The COPO obtained by physical or chemical methods has to be refined for human consumption. The final solid, called orujillo, is commonly used as a biomass for energy production.

The apparition of alperujo was supposed to be a great advantage for olive oil mills because the liquid waste (alpechin) was removed, but it was a serious inconvenience for COPO extractions with regard to the high humidity of the new semi-solid waste, or alperujo. Previous to the two-phase extraction system, the solid waste, or orujo, from the three-phase extraction system was treated with lower humidity (50%) than the alperujo (70%). Nowadays, despite the use of the final solid as biomass, the extraction of olive-pomace oil does not, in many cases, have economic advantages. In addition, the olive oil mills are improving the centrifugation systems in order to increase the quantity of olive oil, producing alperujo with lower oil concentrations. Consequently, the higher humidity in addition to the high organic content of alperujo complicate the COPO extraction, higher temperatures in heat dryers or alperujo with lower oil content. Therefore, pre-treatment alternatives are necessary to properly process the alperujo in the OPO extractor and improve the oil extraction balance and quality, while at the same time obtain new components and add value to the product.

1.4 Minor components in OPO

Interest in olive-pomace oil is growing due to its economic advantages. It is cheaper than olive oil, and contains many minor components with bioactivities. OPO contains all of the functional compounds found in virgin olive oil, except for the polyphenols, in addition to other biologically active components (De la Puerta et al., 2009; Ruiz-Gutiérrez et al., 2009) that could be solubilised from leaves, skin or seeds of olives, depending on the extraction systems.

Phytosterols, tocopherols, aliphatic alcohols, squalene and triterpenic acid are some of the most important compounds that make the minor components an interesting fraction from the point of view of bioactive compounds that are agents for disease prevention.

The phytosterol's structure is similar to cholesterol, and they are a powerful agent in the cholesterol-lowering effects in human blood (Jiménez-Escrig et al., 2006) and as a cytostatic agent in inflammatory and tumoral diseases (Sáenz et al., 1998).

Tocopherols (α -, β -, and γ -form) are present in high concentrations in OPO. α -tocopherol is an essential micronutrient involved in several oxidative stress processes related to atherosclerosis, Alzheimer's disease, accelerated aging and cancer (Mardones & Rigotti, 2004). Recently, biological activities against diseases like cancer in animal models have been also attributed to γ -form (Ju et al., 2010).

There is also squalene in olive-pomace oil. This compound has a beneficial effect on atherosclerotic lesions (Guillén et al., 2008, Bullon et al., 2009), dermatitis (Kelly et al., 1999)

and cellular proliferation and apoptosis in skin and intestinal cancers (Rao, 1998). After being absorbed by the human skin surface, squalene acts as a defence against oxidative stress due to the exposure to ultraviolet (UV) radiation from sunlight.

Aliphatic alcohols with long-chain fatty alcohols (C26 or hexacosanol, C28 or octacosanol and C30 or triacontanol) obtained from OPO have shown activity in reducing the release of different inflammatory mediators (Fernández-Arche et al., 2009), reducing platelet aggregation and lowering cholesterol (Taylor et al., 2003, Singh et al., 2006).

Uvaol and erythrodiol are the triterpenic alcohol fraction present in OPO. They are active antioxidant agents in the microsomal membranes of rat liver (Perona et al., 2005), with positive effects on the inflammatory process (Márquez-Martín et al., 2006), or in the prevention and treatment of brain tumours and other cancers (Martín et al., 2009).

1.5 Thermal pre-treatments

Alperujo is a high humidity solid that needs special pre-treatments to obtain a viable utilisation of all its phases. Only a few pre-treatments have been proposed for the total utilisation of alperujo, extracting the main interesting fractions. One of the more attractive processes is based on thermal pre-treatments that allow the recovery of all of the bioactive compounds and valuable fractions, making possible the utilisation of alperujo (Fernández-Bolaños et al., 2004). Thermal treatments produce the solubilisation of bioactive compounds to the liquid phase, leaving a final solid enriched in oil, cellulose and proteins. From the liquid, it is possible to extract and purify the bioactive compounds that confer healthy properties to olive oil, mainly phenols such as hydroxytyrosol (HT). HT is one of the more important phenols in the olive oil and fruit because it has excellent activities as a pharmacological and antioxidant agent (Fernández-Bolaños et al., 2002). HT has been recently commercialised by a patented system (Fernández-Bolaños et al., 2005). In addition to other important compounds, a novel phenol has been isolated and purified for the first time: 3,4-dihydroxyphenylglycol (DHPG). DHPG has never been studied as a natural antioxidant or functional compound with a higher antiradical activity and reducing power than the potent HT (Rodríguez et al., 2007b). After the thermal treatment and the solid-liquid separation, a solid that is rich in cellulose and oil is obtained. The cellulose is easy to extract and use as a source of fermentable sugar, animal feed or fertiliser (Rodríguez et al., 2007a). The thermal reaction improves the concentration in oil of minor components with functional activities. In addition, phenols increase in the liquid due to the solubilisation, with this fraction a rich source of interesting phenols, sugar and oligosaccharides, all of them with a potential use in the food or nutraceutical industry.

This alternative pre-treatment not only increases the concentration of oil in the final solid, but also the content of minor components in COPO prior to the refining process. The thermal treatment improves the functional profile, enhancing the quality and healthy properties of this oil (Lama-Muñoz et al., 2011). The application of thermal pre-treatment to alperujo makes the extraction of olive-pomace oil easier, improving its functional composition. On the other hand, it is important to note that all chemical changes of fats and oils at elevated temperatures result in oxidation, hydrolysis, polymerisation, isomerisation or cyclisation reactions (Quiles et al., 2002, Valavanidis et al., 2004). All of these reactions may be promoted by oxygen, moisture, traces of metal and free radicals (Quiles et al., 2002). Several factors, such as contact with the air, the temperature and the length of heating, the

type of vessel, the degree of oil unsaturation and the presence of pro-oxidants or antioxidants, affect the overall performance of oil (Andrikopoulos et al., 2002). In this work, the effect of two different thermal pre-treatments on COPO composition has been individually studied to balance the positive and negative factors in the final COPO.

1.5.1 Steam explosion system (SES)

The SES is commonly used as a hydrolytic process for lignocellulosic material utilisation (McMillan, 1994). This process (Figure 2) combines chemical and physical effects on lignocellulosic materials. The material is treated with high-pressure saturated steam for a few minutes and then the pressure is swiftly reduced, causing the materials to undergo an explosive decompression. The process causes hemicellulose degradation and lignin transformation due to high temperature, increasing the solubilisation of interesting compounds not only into the aqueous phase but also into the oil fraction. It is used mainly for the treatment of bagasse, such as wheat or rice straw, sugar cane, etc. The pre-treatment can enhance the bio-digestibility of the wastes for bioprocess applications to obtain, for instance, ethanol or biogas, and to increase the accessibility of the enzymes to the materials (De Bari et al., 2004; Palmarola-Adrados et al., 2004; Kurabi et al., 2005). High pressures (10-40 Kg/cm²) and temperatures (180-240 °C) are applied with or without the addition of acid in a short period of time, followed by explosive depressurisation. The SES makes it possible to obtain a final solid that is rich in COPO from alperujo. The thermal treatment solubilises a high proportion of solid, leaving behind components such as oil, proteins and cellulose. All these components are concentrated in the final solid.

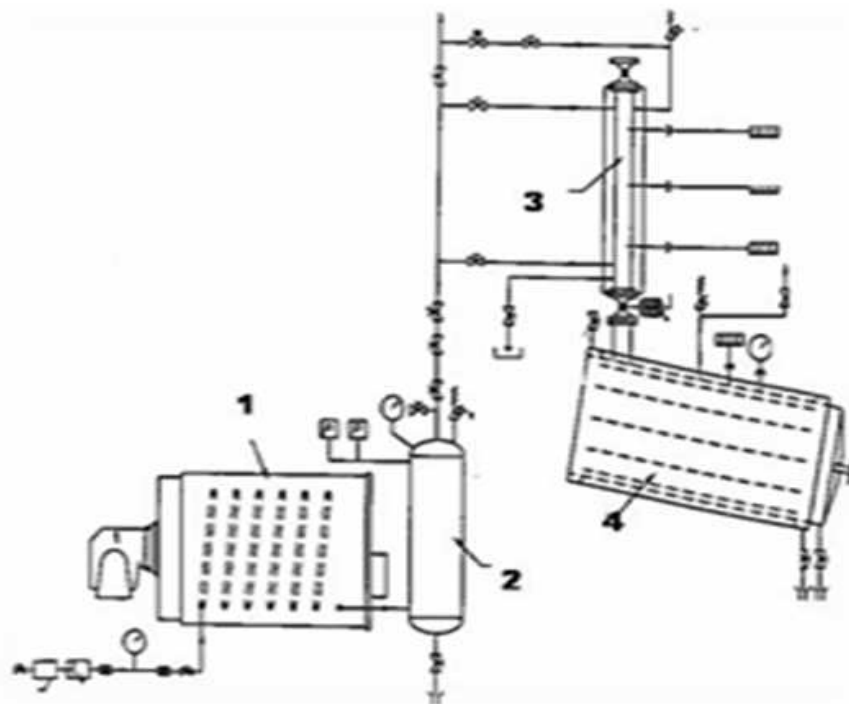

Fig. 2. Steam Explosion System scheme. Laboratory pilot unit designed in the Instituto de la Grasa (Seville, Spain), equipped with: 1) steam generator, 2) steam accumulator, 3) 2 L reactor stainless-steel and 4) expansion chamber.

1.5.2 New steam treatment (ST)

The system scheme is shown in **Figure 3**. A lower range of pressure and temperatures (3-9 Kg/cm² and 140-180 °C) than SES is applied for a longer period of time (15-90 min) in the novel system. The conditions and the contact of steam with the sample have been successfully improved, avoiding the technical complications and the high costs of the SES. This treatment has been recently patented to treat olive oil wastes, and the first tests have been carried out to assess its industrial viability for alperujo utilisation (Fernández-Bolaños et al., 2011).

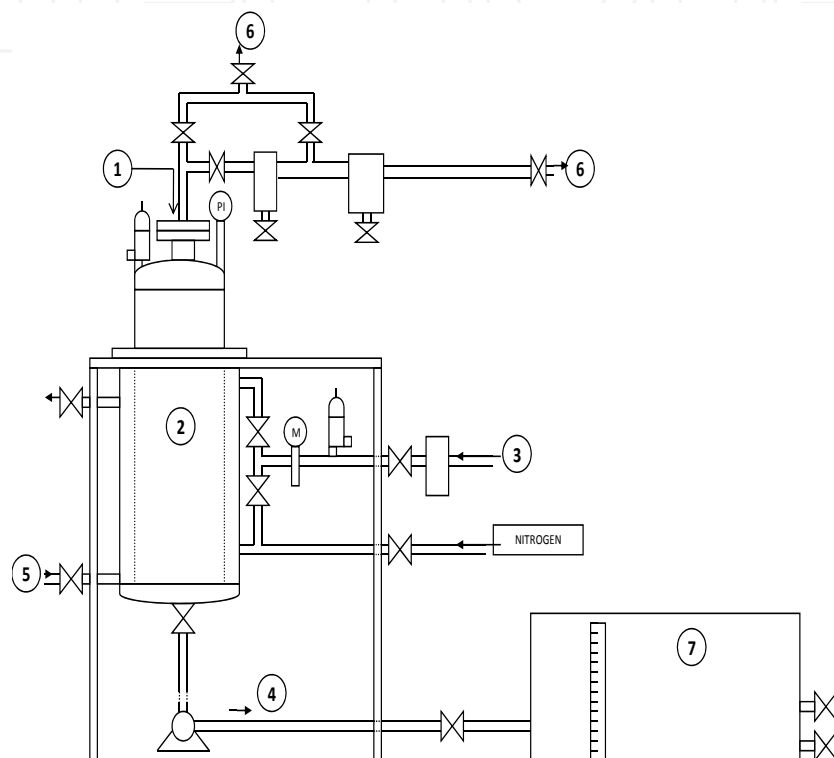

Fig. 3. New steam treatment (ST) reactor scheme designed in the Instituto de la Grasa (Seville, Spain) with: 1) sample entrance, 2) reactor chamber (100 L), 3) water steam, 4) sample exit, 5) cold water for refrigeration system, 6) vacuum and 7) solid-liquid separation.

The sample is introduced into the reaction chamber together with water steam. The sample temperature is increased up to 190°C for 30-60 minutes. After the reaction time, the sample is cooled with indirect water as a refrigerant. The liquid and solid phases of the treated sample are separated and the solid is finally extracted to obtain the crude olive-pomace oil.

The advantages of both systems are based on the important solubilisation of the initial solid to the liquid phase that occurs during the thermal treatment, leaving a final solid in which several components like oil, cellulose and protein are concentrated. The humidity of the final solid is also easier to remove by centrifugation or filtration, simplifying the drying process and the undesirable compounds that are formed at high temperatures.

In addition, the liquid phase is rich in bioactive compounds that are easy to extract. All these factors make possible the total utilisation of olive oil wastes, diminishing their environmental impact (Rodríguez et al., 2007a).

First, the application of SES on alperujo in order to obtain pomace olive oil was studied with or without acid as a catalytic agent. Due to the technical disadvantages of SES and to make the use of thermal pre-treatment in OPO mills easier and more convenient low severities, no depressurisation or acid addition were used in the new system (ST).

2. Experimental procedures

Samples of stored olive pomace or alperujo were collected from the COPO extraction factory Oleícola El Tejar (Córdoba, Spain) with 70% humidity. This by-product is generated as a waste from the two-phase olive oil extraction system.

2.1 Thermal treatments

The thermal treatments were carried out in the Instituto de la Grasa (CSIC) pilot plant by the steam explosion system and a new thermal system:

- a. The SES was carried out using a flash hydrolysis laboratory pilot unit with a 2 L reactor. The reactor was equipped with a quick-opening ball valve for the final explosion into the expansion chamber. Alperujo samples of 250 g were treated with saturated steam in a 2 L reactor with a maximum operating pressure of 40 Kg/cm². The reactor was equipped with a quick-opening ball valve and an electronic device programmed for the accurate control of steam time and temperature for the final steam explosion. Prior to the treatment, some of the samples were acidified with H₃PO₄. The acid was added to the moist sample so as to reach a final concentration of 2,5 % (v/v). After the treatment, the samples were collected and filtered in vacuo through filter paper using a Buchner funnel.
- b. The new ST reactor has recently been patented (Fernández-Bolaños et al., 2011). It has a 100 L capacity stainless steel reservoir that can operate at temperatures between 50 and 190 °C by direct heating and at a maximum pressure of 9 Kg/cm². The system allows the appropriate treatment of alperujo without steam explosion or high pressures and temperatures. The wet treated material was filtered by centrifugation at 4700 g (Comteifa, S.L., Barcelona, Spain) to separate the solids and liquids.

After solid separation, the solid phase was dried in a stove at 50 °C, and the reduction (%) in the mass of the solid phase was determined.

2.2 Analytical determinations

Oil was extracted from the treated solid obtained by SES and ST with n-hexane using a Soxhlet apparatus. The obtained oils were filtered and stored at -20 °C until analysis. Oil content and fat enrichment (pitted dry matter) were determined and compared with the values for untreated alperujo samples.

Determination of the concentrations of aliphatic alcohols, sterols and triterpenic dialcohols (erythrodiol and uvaol) was performed according to the Commission Regulation (EEC) No 2568/91 for olive oil and pomace oil. After the silylation reaction, 1 mL of heptane was added to the mixture, and 1 µL of the solution was injected into an Agilent 7890A gas chromatograph system (Agilent Technologies, Palo Alto, USA) equipped with an FID detector. The analytical column was an HP-5 (5%-phenyl)-methylpolysiloxane column (30 m x 0,32 mm i.d., 0,25 µm film thickness). The results were expressed as mg/kg of oil.

Tocopherols were evaluated using the IUPAC 2.432 method. Results were expressed as mg/kg of oil.

The wax and squalene compositions were determined according to the European Regulation EEC/183/93, by separation on a silica gel 60 (70-230 mesh ASTM) chromatographic column (Merck KGaA, Darmstadt, Germany) using hexane/ether (98:2) as the eluent with a few drops of Sudan I as a colorant. Dodecyl arachidate (Sigma) and squalane (Fluka) were added as internal standards. The results were expressed as mg/kg of oil.

Polar compounds, triglycerides and their derivatives oxidise and hydrolyse were prepared using solid-phase extraction and size-exclusion chromatography and monostearin as internal standard (Márquez -Ruiz et al., 1996). An aliquot (20 μ L) of the final solution was injected into a Hewlett Packard Series 1050 HPLC system equipped with a refractive index detector (LaChrom L-7490 Merck) and a 100- \AA PL gel column (5 μ m) (Agilent). Elution was performed at 0,6 mL/min, with tetrahydrofuran as the mobile phase.

Determination of fatty acid, free acidity and peroxide value (PV) was carried out according to the Official Methods described in the European Community Regulation EEC/2568/91. The results were expressed as the percentage of oleic acid. The peroxide value was expressed in milliequivalents of active oxygen per kilogram of oil (mequiv O₂/kg oil).

The indexes K_{232} , K_{270} and ΔK were determined using the European Communities official methods (European Union Commission, 1991). Oil samples were diluted in isooctane and placed into a 1 cm quartz cuvette; for values calculation, each solution was analysed at 270 and 232 nm, with isooctane as a blank.

3. Results and discussion

Both systems allow the utilisation of the final solid for crude olive-pomace oil extraction. These COPOs have been characterised to assess the positive and negative effects of both treatments on its composition. The SES was studied as a commonly used method for lignocellulosic materials, and the ST was designed to simplify the first system and to diminish the negative effects of SES on crude olive-pomace oil. The lipid fraction of POO extracted from solids treated with either treatment was evaluated, and the minor components were also characterised, in the case of the ST.

3.1 Steam explosion system (SES)

An average temperature of 200 °C and a time of 5 minutes were used with or without acid impregnation of alperujo. The acid increases the severity of the treatment, enhancing the oxidation of the samples. A vacuum was applied to one of the treatments, with acid addition in order to diminish the possible oxidative effect of oxygen at high temperatures and pressures. The results showed (**Table 1**) an important solubilisation of the solid in all treatment. In addition, the oil was concentrated in the final solid from 8,3 up to 19,9 % with respect to the dry final solid. Despite the high level of acidity in the initial sample after the treatment, these values decreased.

K_{232} and K_{270} are simple and useful parameters for assessing the state of oxidation of olive oil. The coefficient of specific extinction at 232 nm is related to the presence of products of

the primary stage of oxidation (hydroperoxides) and conjugated dienes, which are formed by a shift in one of the double bonds. The extinction coefficient at 270 nm is related to the presence of products of secondary oxidation (carbonylic compounds) and conjugated trienes (the primary oxidation products of linolenic acid).

The K_{232} values of all treated samples were lower than the untreated alperujo, unlike the K_{270} values in which only the sample treated with vacuum and without acid presented a similar absorbance at 270 nm. Only when vacuum and acid were applied to the SES did the value of K_{270} exceed the maximum concentration in ROPO (2,0), with all the ΔK values lower than the maximum in ROPO (0,2). All these oxidised compounds diminished after the refining process.

The polar compound values that show the alteration level by the non-volatile compounds of oil are practically the same in all treatments, except when the acid and the vacuum are used simultaneously. Polar compounds provide an idea not only of oxidative reactions, but also of hydrolytic degradation, because they are partial constituents of FFA and glycerides.

Curiously, the concentration of oxidised triglycerides and polymers are lower after the SES treatments. This result could be explained by their partial solubilisation during the thermal treatment in the liquid phases that are previously separated by the oil extraction.

	Untreated sample	SES (200° C, 5 min)	SES (200° C, 5 min, 2,5% H ₃ PO ₄)	SES (200° C, 5 min, vacuum)	SES (200° C, 5 min, 2,5% H ₃ PO ₄ , vacuum)
% of solid reduction	-	51,7	54,6	52,1	58,5
% of oil in final solid	8,3	17,2	18,0	16,9	19,9
Acidity (% oleic acid)	6,76	4,97	4,44	5,08	5,48
K_{232}	5,72	4,57	3,23	5,18	5,21
K_{270}	1,27	1,74	1,44	1,24	2,37
ΔK	-0,03	0,00	0,04	0,06	0,07
Polar compounds mg/g	114,3	116,59	112,81	111,37	129,87
Oxidised Triglycerides ^a	1,61	1,25	1,34	1,41	1,36
Diglycerides ^a	3,10	4,47	4,83	4,37	5,13
Monoglycerides ^a	0,42	0,53	0,40	0,49	0,56
FFA (% as oleic acid)	6,10	5,28	4,49	4,66	5,73
Polymers ^a	0,23	0,14	0,23	0,21	0,21

^a % with regard to the oil sample.

Table 1. Solid reduction, oil concentration in final solid and chemical characteristics of crude olive-pomace oil treated or untreated by SES in several conditions.

The quantity of triglycerides decreased after the SES treatment, with an increased presence of diglycerides and monoglycerides as an unmistakable sign of hydrolytic degradation.

The oxidative effects do not seem to be the main cause of the COPO alteration during the SES treatment, while hydrolysis seems to be an important effect on the triglyceride loss.

The composition of triglycerides was determined and the results are shown in the **Table 2**. The main triglyceride peaks in all samples were oleic-oleic-oleic (OOO), oleic-oleic-palmitic (OOP) and linoleic-oleic-oleic (LOO).

Despite the low quality of the initial oil, the relation of triglycerides was not altered by SES. As expected, in the crude olive-pomace oil obtained after SES treatment, the total content of triglycerides decreased up to 22% compared to the oil obtained from the untreated alperujo. Despite the high severity, only 22% of triglyceride composition was lost, with the rest susceptible for refining. The oxidative conditions of SES treatment were minimised using a vacuum or avoiding the acid addition.

The great advantages of the SES application on alperujo are based, in addition to other reasons, on the solid reduction (up to 58%) and oil concentration in the final solid (up to 20%). Because the triglycerides (TG) are concentrated, their loss is not a significant or negative factor to limit the use of this system. These reasons make technically possible the extraction of the crude olive-pomace oil from one sample of alperujo treated by SES. Therefore, the application of SES to this kind of alperujo allows for the obtaining of a final solid rich in oil in a high concentration that is susceptible for further refining processes for olive-pomace oil production. However, the technical inconveniences of SES such as high temperatures and pressures or the explosive decompression make it an inadequate system for olive-pomace oil extractors.

Triglycerides	Untreated sample		SES (200° C, 5 min) treated sample	
	Peak area	% of total glycerides Mean ± SD	Peak area	% of total glycerides Mean ± SD
LLL	18039	0,7 ± 0,05	11076	0,6 ± 0,02
LnLO	15271	0,6 ± 0,03	5886	0,3 ± 0,01
OLL+PoLO	99759	4,0 ± 0,10	75243	3,9 ± 0,77
PLL+LnOO	62860	2,5 ± 0,15	32818	1,7 ± 0,26
POLn	23935	1,0 ± 0,07	0	0,0 ± 0,00
LOO	404446	16,1 ± 1,02	321011	16,6 ± 1,23
LOP	154422	6,2 ± 0,81	126669	6,5 ± 0,87
LPP	4000	0,2 ± 0,01	6064	0,3 ± 0,02
OOO	959632	38,3 ± 1,67	788016	40,7 ± 2,03
OOP	448959	17,9 ± 1,11	364371	18,8 ± 1,30
POP	57959	2,3 ± 0,90	39691	2,0 ± 0,11
SOO	157822	6,3 ± 1,43	108877	5,6 ± 0,95
POS	28350	1,1 ± 0,03	21116	1,1 ± 0,05
AOO	49158	2,0 ± 0,16	26398	1,4 ± 0,06
Área total	2504443		1938316	

P, palmitic, Po, palmitoleic, M, margaric, S, stearic, O, oleic, L, linoleic, Ln, linolenic, and A, arachidic acids

Table 2. Triglycerides composition of crude olive-pomace oil obtained from alperujo untreated and treated by SES.

3.2 Effects of the new steam treatment

The ST effect on POO composition was determined by characterisation of the fatty acid fraction. After the thermal treatment in the range of 150-170°C for 60 min (Table 3), the final treated solid had an increase in oil yield up to 97%, with a reduction in solids up to 35,6-47,6% by solubilisation. The oxidative damage was lower in the new treatment. The analysis of the polar fraction showed that oxidised triglycerides and peroxide values increased slightly and that no polymerisation reactions occurred. The hydrolytic process is shown in the diglycerides increasing from 2,5 to 6,6%, with the FFA and the unsaponifiable matter for all treatments remaining constant.

	Untreated sample	ST (150° C, 60 min)	ST (160° C, 60 min)	ST (170° C, 60 min)
% of solid reduction	-	35,6	47,1	47,6
% of oil in final solid	8,1	11,8	14,3	16,0
Acidity (% oleic acid)	3,6	4,7	4,9	5,1
Peroxide Values (meq/Kg)	8,7	9,4	10,9	12,3
Oxidised Triglycerides ^a	0,7	1,1	1,1	1,6
Diglycerides ^a	2,5	5,2	6,6	6,6
Monoglycerides ^a				
FFA (% as oleic acid)	3,3	2,8	2,9	2,8
Unsaponifiable matter (%)	2,53	3,02	2,50	2,54

Table 3. Solid reduction, oil concentration in final solid and chemical characteristics of crude olive-pomace oil treated or untreated by ST at 150, 160 and 170°C for one hour. ^a % with regard to the oil sample.

The concentration of minor components (Table 4) was significantly increased by ST. Sterols, aliphatic alcohols, triterpenic alcohols, and squalene increased up to 33%, 57%, 23% and 43%, respectively. In addition, the content of tocopherols increased up to 57% compared to untreated POO. This increase is due to solubilisation during the thermal treatment. The waxes level is also increased because of the high solubilisation from the external cuticle of the olive fruit and the leaves. Waxes are easily removed by the refining of COPO.

The samples of alperujo had been stored for a long time and the oil was partially extracted by centrifugation in OPO extractors just before pitting. The alperujo was chosen because its low fat concentration makes the COPO extraction economically unviable. In this condition, the initial oil has a very low quality, as previously shown in the tables. The analysed oils showed, despite the low quality of initial oil present in the alperujo studied, that the effect of thermal treatment increases slightly the values of oxidised components and hydrolytic degradation. All COPOs obtained after the thermal treatments are susceptible for a posterior refining process for OPO obtention.

Components	Untreated sample	ST (150°C, 60 min)	ST (160°C, 60 min)	ST (170°C, 60 min)
Sterols	4927 (104)	5687 (291)	6546 (216)	6555 (298)
Aliphatic alcohols	4065 (77)	5532 (603)	5880 (283)	6389 (68)
Triterpenic alcohols	992 (58)	1054 (34)	1220 (124)	1189 (107)
Waxes	1535 (3)	2971 (5)	3124 (94)	3461 (110)
Squalene	2404 (36)	2472 (11)	2729 (109)	3439 (171)
Tocopherols	425 (33)	460 (6)	668 (14)	533 (20)

Table 4. Total minor component composition (mg/kg \pm SD) of oils from steam-treated and untreated alperujo. Numbers between parentheses indicate the standard deviation of three replicates.

For human consumption, the refining process of OPO is necessary. The refining (physical or chemical) process eliminates undesirable compounds (peroxides, degradation products, volatile compounds responsible for off-flavours, free fatty acids, etc.) but also results in the loss of valuable bioactive compounds and natural antioxidants (Ruiz-Méndez et al., 2008). The new trends of refining systems involve losing as few minor components as possible to obtain a final OPO that is rich in the minor components. The thermal treatments increase the minor component of COPO that help to obtain a final olive-pomace oil rich in interesting compounds, whose concentrations might be higher after the refining process, mainly using the new physical systems. Moreover, some of these minor components are recuperated during the refining, such as squalene, the concentration of which is increased up to 43 % after the pre-treatment. After extraction, the defatted solid is lacking in phenols and then in phytoxic compounds for further bio-utilisation and rich in components like cellulose and protein.

Figure 4 shows the main aspects of both thermal systems. The high difference between temperatures and pressures together with the absence of explosive decompression makes ST more appropriate and economically viable for industrial applications. A longer period of reaction time is necessary to treat with ST, but is easily applicable in an industrial continuous reactor. The percentage of solid reduction and, consequently, the final oil concentration show that despite the high severity difference between both treatments, there is not a significant difference in the results. Then, the new ST provides the major advantages of SES without technical complications.

Thus, the positive effect of a novel thermal treatment for the extraction of crude olive-pomace oil that could improve the commercial value of OPO and its bioactivities by increasing the concentrations of minor components concentration has been demonstrated. This treatment also significantly reduces the cost of oil extraction by centrifugation or solvent extraction because the starting solid is more concentrated in oil and is drier than untreated alperujo.

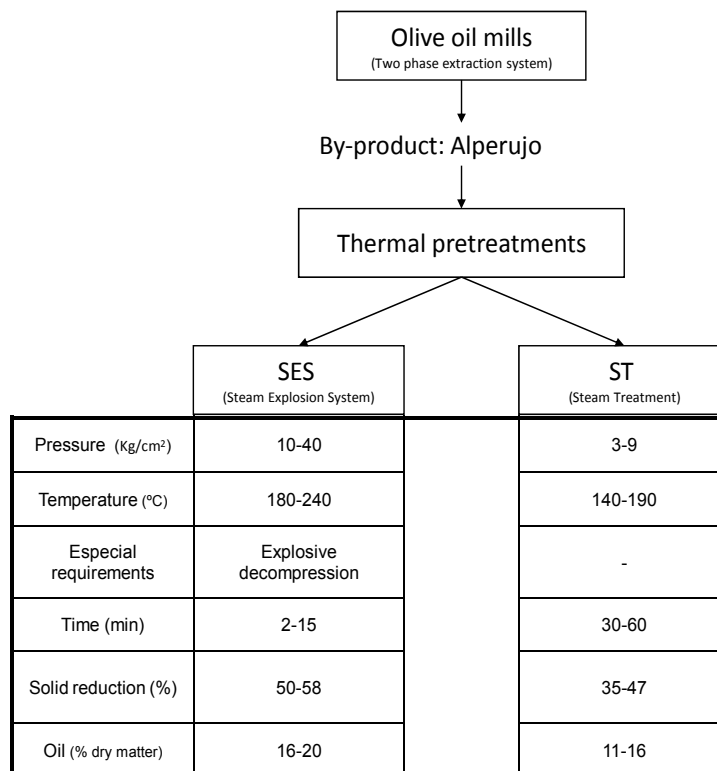

Fig. 4. Comparative scheme of two thermal pre-treatments used for alperujo utilisation.

4. Conclusion

The new treatment ST not only maintains the advantages of the SES with regard to the concentration of oil in the final solid and phase separation, but also diminishes the oxidation and significantly improves the concentration of the most interesting components of the minor fractions of POO. Thus, the application of ST enhances the functional properties of this new POO, increasing the oil extraction yield and the total recovery of bioactive compounds from the refining process.

The steam treatment offers not only serious advantages in terms of the oil but also in terms of the total recovery of alperujo as described above. The application of ST to treat olive oil wastes allows the phase separation and the concentration of interesting compounds and components in each phase. In the liquid phase, bioactive compounds like phenols and oligosaccharides are solubilised and are easy to extract. In the solid fraction, the oil and cellulose are concentrated. After the oil extraction, the solid has a low content of phytotoxics that are in the liquid phase, and therefore, it is susceptible for bio-treatment for the total utilisation of this fraction.

5. Acknowledgment

Financial support for this study was provided by Ministerio de Ciencia e Innovación and Junta de Andalucía through projects AGL 2009-12352 (ALI) and P08-AGR-03751 respectively.

6. References

- Andrikopoulos, N. K.; Kalogeropoulos, N.; Falirea, A. & Barbagianni, M. N. (2002). Performance of virgin olive oil and vegetable shortening during domestic deep-frying and pan-frying of potatoes. *International Journal of Food Science and Technology*, Vol. 37, No.2, (February 2002), pp. 177-190, ISSN 0950-5423
- Antonopoulos, K.; Valet, N.; Spiratos, D. & Siragakis, G. (2006). Olive oil and pomace olive oil processing. *Grasas y Aceites*, Vol.57, No.1, (January-March 2006), pp.56-67, ISSN 0017-3495
- Aragón, J.M. & Palancar, M.C. (2001). *Improlive 2000. Present and future of Alpeorujo*, pp. 242-300, ISBN 84-7491-593-7, Editorial Complutense S. A., Madrid.
- Borja, R.; Alba, J. & Banks, C.J. (1997). Impact of the main phenolic compounds of olive mill wastewater (OMW) on the kinetics of acetoclastic methanogenesis. *Process Biochemistry*. Vol.32, No.2, (February 1997), pp. 121-133, ISSN 1359-5113
- Boskou, D. (2000). Olive oil. *World Review of Nutrition & Dietetics*. Vol.87, pp.56-77, ISSN 0084-2230
- Bullon, P.; Quiles, J.L.; Morillo, J.M.; Rubini, C.; Goteri, G.; Granados-Principal, S.; Battino, M. & Ramirez-Tortosa, M.C. (2009). Gingival vascular damage in atherosclerotic rabbits: hydroxytyrosol and squalene benefits. *Food and Chemical Toxicology*, Vol 47, No.9, (September 2009), pp. 2327-2331, ISSN: 0278-6915
- Commission Regulation (EEC) No 2568/91 of 11 July 1991 on the 454 characteristics of olive oil and olive-residue oil and the relevant methods of 455 analysis. *Off. J. Eur. Communities*. 1991. 248.
- Commission Regulation (EEC) No 183/93 L 28 of the 29 January 1993 on the 462 characteristics of olive oil and olive-residue oil and the relevant methods of 463 analysis. *Off. J. Eur. Communities*. 1993.
- De Bari, I.; Cuna, D.; Nanna, F. & Braccio, G. (2004). Ethanol production in immobilized-cell bioreactors from mixed sugar and enzymatic hydrolyzates of steam-exploded biomass. *Biotechnology and Applied Biochemistry*, Vol.114, No.1-3, (April 2004), pp. 539-557, ISSN 0273-2289
- De la Puerta, R.; Márquez-Martín, A.; Fernández-Arche, A. & Ruiz-Gutiérrez, V. (2009). Influence of dietary fat on oxidative stress and inflammation in murine macrophages. *Nutrition*, Vol. 25, No.5, (February 2009), pp. 548-554, ISSN: 0899-9007
- Jiménez-Escrig, A.; Santos-Hidalgo, A. B. & Saura-Calixto, F. (2006). Common sources and estimated intake of plant sterols in the Spanish diet. *Journal of Agriculture and Food Chemistry*. Vol. 54, No.9, (May 2006), p.p.3462-3471, ISSN 0021-8561
- Espínola-Lozano, F. (2003). Technological change in the extraction of olive pomace oils. *Alimentación Equipos y Tecnología*, Vol.22, pp. 60-64, ISSN 0212- 1689
- European Union Commission (1991). Regulation 2568/91. Official Journal of the European Communities.
- Fernandez-Arche, A.; Marquez-Martin, A.; de la Puerta Vazquez, R.; Perona, J.; Terencio, C.; Pérez-Camino, C. & Ruiz-Gutierrez, V. (2009). Long-chain fatty alcohols from pomace olive oil modulate the release of proinflammatory mediators. *Journal of Nutritional Biochemistry*, Vol.20, No.3, (March 2009), pp. 155-162, ISSN: 0955-2863
- Fernández-Bolaños, J.; Rodríguez, G.; Rodríguez, R.; Heredia, A.; Guillén, R. & Jiménez, A. (2002). Production in large quantities of highly purified hydroxytyrosol from liquid-solid waste of two-phase olive oil processing or "alperujo". *Journal of*

- Agriculture and Food Chemistry*. Vol.50, No.22, (October 2002), pp. 6804–6811, ISSN 0021-8561
- Fernández-Bolaños; J.; Rodríguez; G.; Gómez; E.; Guillén; R.; Jiménez; A. & Heredia, A. (2004). Total recovery of the waste of two-phase olive oil processing: isolation of added-value compounds. *Journal of Agricultural and Food Chemistry*, Vol.52, No.19, (August 2004), pp. 5849–5855, ISSN 0021-8561
- Fernández-Bolaños, J.; Heredia, A.; Rodríguez, G.; Rodríguez, R.; Jiménez, A. & Guillén, R. (2005). Methods for obtaining purified hydroxytyrosol from products and by-products derived from the olive tree, patent No. US 6849770 B2
- Fernández-Bolaños; J.; Rodríguez; G.; Lama, A. & Sanchez, P. (2011). Dispositivo y procedimiento para el tratamiento de los subproductos de la obtención de aceite de oliva, patent No. PCT/ES2011/070583.
- Guillén, N.; Acín; S.; Navarro; M. A.; Perona; J. S.; Arbonés-Mainar; J. M.; Arnal; C.; Sarría; A. J.; Surra; J. C.; Carnicer, R.; Orman, I.; Segovia, J. C.; Ruiz-Gutiérrez, V. & Osada, J. (2008). Squalene in a sex-dependent manner modulates atherosclerotic lesion which correlates with hepatic fat content in apoE-knockout male mice. *Atherosclerosis*, Vol.197, No.1, (March 2008), pp. 72-83, ISSN 0021-9150
- Gomes, T. & Caponio, F. (1997). Evaluation of the state of oxidation of crude olive-pomace oils. Influence of olive-pomace drying and oil extraction with solvent. *Journal of Agriculture and Food Chemistry*, Vol.45, No.4, (April 1997), pp. 1381-1384, ISSN 0021-8561
- International Union of Pure and Applied Chemistry. (1992). Determination of tocopherols and tocotrienols in vegetable oils and fats by high performance liquid chromatography. *Standard Methods for the Analysis of Oils, Fats and Derivatives 1st Supplement to the 7th Edition*. Blackwell Scientific Publications, Osney Mead, Oxford.
- Ju, J.; Picinich, S. C.; Yang, Z.; Zhao, Y.; Suh, N.; Kong, Ah-Ng & Yang, C. S. (2009). Cancer-preventive activities of tocopherols and tocotrienols. *Carcinogenesis*, Vol.31, No.4, (September 2009), pp.533-542, ISSN 0143-3334
- Kelly, G.S. (1999). Squalene and its potential clinical uses. *Alternative Medicine Review*, Vol. 4, No.1, (February 1999), pp. 29-36, ISSN 1089-5159
- Kurabi, A.; Berlin, A.; Gilkes, N.; Kilburn, D.; Bura, R.; Robinson, J.; Markov, A; Skomarovsky, A.; GustaKov, A.; Okunev, O.; Sinitsyn, A.; Gregg, D.; Xie, D. & Saddler, L. (2005). Enzymatic hydrolysis of steam-exploded and ethanol organosolv-pretrated Douglas-Fir by novel and commercial fungal-cellulase. *Applied Biochemistry and Biotechnology*, Vol.212, No.121-124, (March 2005), pp. 219-230, ISSN 0885-4513
- Lama-Muñoz, A.; Rodríguez-Gutiérrez, G.; Rubio-Senent, F.; Gómez-Carretero, A. & Fernández-Bolaños, J. (2011). New Hydrothermal Treatment of Alperujo Enhances the Content on Bioactive Minor Components in Crude Pomace Olive Oil. *Journal of Agriculture and Food Chemistry*, Vol.59, No.4, (February 2011), pp. 1115-1123, ISSN 0021-8561
- Lesage-Meessen, L.; Navarro, D.; Maunier, S.; Sigoillot, J.C.; Lorquin, J.; Delattre, M.; Simon, J.L.; Asther, M. & Labat, M. (2001). Simple phenolic content in olive oil residues as a function of extraction systems. *Food Chemistry*, Vol.75, No.4, (December 2001), pp. 501-507, ISSN 0308-8146

- León-Camacho, M.; Viera-Alcaide, I. & Ruiz-Méndez, M.V. (2003). Elimination of polycyclic aromatic hydrocarbons by bleaching of olive pomace oil. *European Journal of Lipid Science and Technology*, Vol.105, No.1, (January 2003), pp. 9-16, ISSN 1438-7697
- McMillan, J.D. (1994). Pretreatment of lignocellulosic biomass. In: M.E. Himmel, J.O. Baker and R.P. Overend, Editors. *Enzymatic Conversion of Biomass for Fuels Production*, American Chemical Society, Washington, DC (1994); pp. 292-324. ISBN 0841229562
- Mardones, P. & Rigotti, A. (2004). Cellular mechanisms of vitamin E uptake: relevance in α -tocopherol metabolism and potential implications for disease. *Journal of Nutritional Biochemistry*, Vol.15, No.5, (May 2005), pp. 252-260, ISSN 0955-2863
- Márquez-Martín, A.; De la Puerta, R.; Fernández-Arche, A.; Ruiz-Gutiérrez, V. & Yaqoob, P. (2006). Modulation of cytokine secretion by pentacyclic triterpenes from olive pomace oil human mononuclear cells. *Cytokine*, Vol.36, No.5-6, (December 2006), pp. 211-217, ISSN 1043-4666
- Márquez-Ruiz, G.; Jorge, N.; Martín-Polvillo, M. & Dobarganes, M.C. (1996). Rapid, quantitative determination of polar compounds in fats and oils by solid-phase extraction and size-exclusion chromatography using monostearin as internal standard. *Journal of Chromatography. A*, Vol.749, No.1-2, (October 1996), pp. 55-60, ISSN 0021-9673
- Martín, R.; Ibeas, E.; Carvalho-Tavares, J.; Hernández, M.; Ruiz-Gutiérrez, V. & Nieto; M. L. (2009). Natural triterpenic diols promote apoptosis in astrocytoma cells through ROS-mediated mitochondrial depolarization and JNK activation. *PLoS ONE*, Vol.4, No.6, (June 2009), pp. e5975, ISSN 1932-6203
- Niaounakis, M. & Halvadakis, P. (2004). Olive-mill waste management: literature review and patent survey, 1st Ed; Typothito-George Dardanos Publications, Athens. ISBN 960-402-123-0
- Palmarola-Adrados, B.; Galbe, M. & Zacchi, G. (2004). Combined steam pretreatment and enzymatic hydrolysis of starch-free wheat fiber. *Applied Biochemistry and Biotechnology*, Vol.113, No.1-3, (Spring 2004), pp. 989-1002, ISSN 0885-4513
- Pérez-Camino, M. C. & Cert, A. (1999). Quantitative determination of hydroxy pentacyclic triterpene acids in vegetable oils. *Journal of Agricultural and Food Chemistry*, Vol.47, No.4, (April 1999), pp. 1558-1562, ISSN 0021-8561
- Pérez-Jiménez, F.; Ruano, J.; Pérez-Martínez, P.; López-Segura, F. & López-Miranda, J. (2007). The influence of olive oil on human health: not a question of fat alone. *Molecular Nutrition and Food Research*, Vol.51, No.10, (October 2007), pp. 1199-1208, ISSN 1613-4125
- Perona, J. S.; Arcemis, C.; Ruiz-Gutiérrez, V. & Catalá, A. (2005). Effect of dietary high-oleic-acid oils that are rich in antioxidants on microsomal lipid peroxidation in rats. *Journal of Agriculture and Food Chemistry*, Vol.53, No.3, (February 2005), pp. 730-735, ISSN 0021-8561
- Quiles, J. L.; Ramírez-Tortosa, M. C.; Gómez, J. A.; Huertas, J. R.; & Mataix, J. (2002). Role of vitamin E and phenolic compounds in the antioxidant capacity; measured by ESR; of virgin olive; olive and sunflower oils after frying. *Food Chemistry*, Vol.76, No.4, (April 2002), pp. 461-468, ISSN 0308-8146
- Rao, C. V.; Newmark, H. L. & Reddy, B. S. (1998). Chemopreventive effect of squalene on colon cancer. *Carcinogenesis*, Vol.19, No.2, (March 1998), pp. 287-290, ISSN 0143-3334

- Rodríguez, G.; Rodríguez, R.; Guillén, R.; Jiménez, A. & Fernández-Bolaños, J. (2007a). Effect of steam treatment of alperujo on the enzymatic saccharification and in vitro digestibility. *Journal of Agriculture and Food Chemistry*, Vol.55, No.1, (January 2007), pp. 136-142, ISSN 0021-8561
- Rodríguez, G.; Rodríguez, R.; Fernández-Bolaños, J.; Guillén, R.; & Jiménez, A. (2007b). Antioxidant activity of effluents during the purification of hydroxytyrosol and 3,4-dihydroxyphenyl glycol from olive oil waste. *European Food Research and Technology*, Vol.224, No.6, (April 2007), pp. 733-741, ISSN 1438-2377
- Rodríguez, G.; Lama, A.; Rodríguez, R.; Jiménez, A.; Guillén, R. & Fernández-Bolaños, J. (2008). Olive stone an attractive source of bioactive and valuable compounds. *Bioresource Technology*. Vol.99, No.13, (September 2008), pp. 5261-5269, ISSN 0960-8524
- Ruiz-Gutiérrez, V.; Sanchez-Perona, J. & Osada, J. (2009). Using refined oil from olive pressings for retarding development of atherosclerosis; reduces levels of triglycerides and specific lipoproteins; and the number of leucocytes carrying the Mac-1 integrin, patent No. WO2005092354-A1
- Ruiz-Méndez, M.V.; López-López, A. & Garrido-Fernández, A. (2008). Characterization and chemometric study of crude and refined oils from table olive by-products. *European Journal of Lipid Science and Technology*, Vol.110, No.6, (June 2008), pp. 537-546, ISSN 1438-7697
- Taylor, J. C.; Rapport, L. & Lockwood, G. B. (2003). Octacosanol in human health. *Nutrition*, Vol.19, No.2, (February 2003), pp. 192-195, ISSN 0899-9007
- Sáenz, M.T.; García, M.D.; Ahumada, M.C. & Ruiz, V. (1998). Cytostatic activity of some compounds from the unsaponifiable fraction obtained from virgin olive oil. *Il Farmaco*, Vol.53, No.6, (June 1998), pp. 448-449, ISSN 0014-827X
- Sánchez, P.; Ruiz, M.V. (2006). Production of pomace olive oil. *Grasas y Aceites*, Vol.57, No.1, (March 2006), pp. 47-55, ISSN 0017-3495
- Singh, D. K.; Li, L. & Porter, T. D. (2006). Policosanol inhibits cholesterol synthesis in hepatoma cells by activation of AMP-kinase. *Journal of Pharmacology and Experimental Therapeutics*, Vol.318, No.6, (May 2006), pp. 1020-1026, ISSN 0022-3565
- Valavanidis, A.; Nisiotou, C.; Papageorghiou, Y.; Kremli, I.; Satravelas, N.; Zinieris, N. & Zygalki, H. (2004). Comparison of the radical scavenging potential of polar and lipidic fractions of olive oil and other vegetable oils under normal conditions and after thermal treatment. *Journal of Agriculture and Food Chemistry*, Vol.52, No.8, (April 2004), pp. 2358-2365, ISSN 0021-8561
- Vlyssides, A.G.; Loizides, M. & Karlis, P.K. (2004). Integrated strategic approach for reusing olive oil extraction. *Journal of Cleaner Production*, Vol.12, pp. 603-611, ISSN 0959-6526

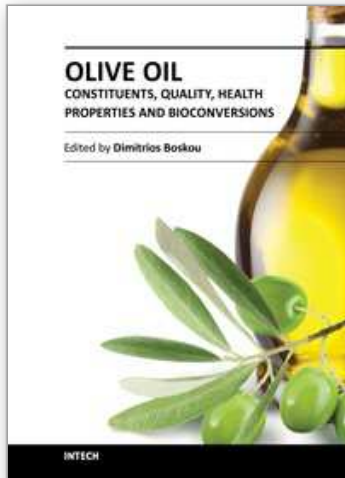

Olive Oil - Constituents, Quality, Health Properties and Bioconversions

Edited by Dr. Dimitrios Boskou

ISBN 978-953-307-921-9

Hard cover, 510 pages

Publisher InTech

Published online 01, February, 2012

Published in print edition February, 2012

The health-promoting effects attributed to olive oil, and the development of the olive oil industry have intensified the quest for new information, stimulating wide areas of research. This book is a source of recently accumulated information. It covers a broad range of topics from chemistry, technology, and quality assessment, to bioavailability and function of important molecules, recovery of bioactive compounds, preparation of olive oil-based functional products, and identification of novel pharmacological targets for the prevention and treatment of certain diseases.

How to reference

In order to correctly reference this scholarly work, feel free to copy and paste the following:

G. Rodríguez-Gutiérrez, A. Lama-Muñoz, M.V. Ruiz-Méndez, F. Rubio-Senent and J. Fernández-Bolaños (2012). New Olive-Pomace Oil Improved by Hydrothermal Pre-Treatments, Olive Oil - Constituents, Quality, Health Properties and Bioconversions, Dr. Dimitrios Boskou (Ed.), ISBN: 978-953-307-921-9, InTech, Available from: <http://www.intechopen.com/books/olive-oil-constituents-quality-health-properties-and-bioconversions/new-pomace-olive-oil-improved-by-hydrothermal-treatment>

INTECH

open science | open minds

InTech Europe

University Campus STeP Ri
Slavka Krautzeka 83/A
51000 Rijeka, Croatia
Phone: +385 (51) 770 447
Fax: +385 (51) 686 166
www.intechopen.com

InTech China

Unit 405, Office Block, Hotel Equatorial Shanghai
No.65, Yan An Road (West), Shanghai, 200040, China
中国上海市延安西路65号上海国际贵都大饭店办公楼405单元
Phone: +86-21-62489820
Fax: +86-21-62489821

© 2012 The Author(s). Licensee IntechOpen. This is an open access article distributed under the terms of the [Creative Commons Attribution 3.0 License](#), which permits unrestricted use, distribution, and reproduction in any medium, provided the original work is properly cited.

IntechOpen

IntechOpen