

We are IntechOpen, the world's leading publisher of Open Access books Built by scientists, for scientists

4,800

Open access books available

122,000

International authors and editors

135M

Downloads

Our authors are among the

154

Countries delivered to

TOP 1%

most cited scientists

12.2%

Contributors from top 500 universities

**WEB OF SCIENCE™**Selection of our books indexed in the Book Citation Index
in Web of Science™ Core Collection (BKCI)

Interested in publishing with us? Contact book.department@intechopen.com

Numbers displayed above are based on latest data collected.

For more information visit www.intechopen.com

Life Support System Virtual Simulators for Mars-500 Ground-Based Experiment

Eduard Kurmazenko¹, Nikolay Khabarovskiy¹, Guzel Kamaletdinova¹,
Evgeniy Demin² and Boris Morukov²

¹Joint-Stock Co. 'NIIchimmash',

²SSC RF-IMBP RAS,

Russia

1. Introduction

A Mars manned mission is practically impossible without resolving some problems on the ground with test subjects involved related to crew life-support psychological stability, fitness to work during a long-duration, self-sustained space mission. One of the problems to be resolved in spaceflight is the crew's health and fitness work. These factors are possible to investigate in a ground experiment to make more effective preparation for interplanetary missions including a Mars mission. Another problem lies in failure-free functioning of on-board systems and first of all the Integrated Regenerative Life-Support System (IRLSS) in the Mars-500 project. The crew plays a key role in maintaining system operability and reliability the entire mission.

In order to make long-duration, self-sustained interplanetary missions a reality it is necessary to provide crew support and its activities under conditions essentially different from those of earth orbital flights.

Specifics of interplanetary flights include:

- long duration (over 960 day) missions with the crew being in confined space that demands:
 - expansion of functions of IRLSS functions related to crew personal;
 - prompt parameters of the crew's environment under spaceflight conditions;
 - the necessity of carrying out the crew's medical control and strain relief on-board the spacecraft.
- Self-sustained manned flight is characterized by:
 - lack of renewal expendables units;
 - the systems incorporated in the IRLSS architecture shell ensure trouble-free performance over the entire flight with minimal spare parts and expendables required;
 - the necessity of decision-making by crew as identification and localization of possible off-normal situations related to the IRLSS due to limited intervention on the part of the ground mission control center to control the crew's actions.

Investigations into prolonged influence of the conditions of self-sustained interplanetary flight on crewmembers' intellectual faculties in operation of the IRLSS are of prime

importance to make a mission a success and cannot be predicted on the basis of theoretical and experimental data, ground experiments conducted shall be aimed first of all at evaluating the operator's effective activities and his psychological condition (attention, vigilance, perception, memory, thinking training) in combination with physiological parameters of the central and vegetative nervous systems.

Actual participation of test subjects in serving operational standard system at first phases of ground simulation of spaceflight to Mars is extremely complicated and economically unprofitable. A more rational approach is the application of standard system virtual simulators interacting with simulation models for both environment and crew as a load component and integrated in a single Hardware/Software Complex for Serving Operational Systems by crew (HSCSOS) intended for system functioning in normal, off-normal and emergency situations resulted in failure of some systems and deviation of environment controllable parameters from specified values. Those situations may include human factor (crew members' decline in fitness to work, activities, etc.).

The purpose of this charter is analysis of all possible approaches to development of similar complexes based on simulation taking into account a long-duration stay of Man in confined space. The analysis results may be used in development of similar hardware/software complexes to analyze complicated human-machine interaction and specialist training for various-purpose Man-Made Ecosystems (MMES).

2. The simulating object: Its engineering architecture and properties

The crews, environment, IRLSS placed in Pressurized Manned Modules (PMM) define a MMES of Interplanetary Spacecraft intended for crewmembers' support and activity as well as other biological object under conditions essentially different from those on Earth (Kurmazenko E.A. et al., 2009).

The distinguished features of the MMES in comparison with natural ecosystem include:

- the necessity of creating system architecture based on processes with intensity significantly exceeding the intensity of natural transformation processes;
- the system architecture should incorporate finite number of engineering devices and units with built-in or embedded man-made technologies;
- the capability of stable functioning is governed by the value of a substance reserve fund of the substances disposed in the PMM confined volume.

The IRLSS as an abiotic component of the MMES intended for long-duration manned missions may be defined as a sophisticated engineering system with devices interacting in time and space to provide crew support based on metabolic product recovery, a minimum of spare parts and expendables to create the conditions which ensure that the crew will be provided with physical and mental stability to a specified degree of reliability (Pravetskiy V.N. et al., 1981).

In generalized state space the MMES as a complicated integral system may be given by

$$C \equiv C(|C|, \bar{C}, \underline{C}). \quad (1)$$

The initial system decomposition allows two interrelated and interacted components to be signed out the IRLSS and external environment:

$$S \equiv S(|S|, \bar{S}); \quad (2)$$

$$E \equiv E(|E|, \bar{E}, \underline{C}), \quad (3)$$

$$C = S \cap E; \quad (4)$$

$$\bar{C} \equiv \bar{S}(|S|, |E|, \bar{E}) \cap \bar{E}(|E|, \bar{E}, |S|), \quad (5)$$

in accordance with the purpose of the C system over each time of functioning.

In the expressions (1)÷(5) the following notation is adopted: C, S, E=the state functions of the MMES, IRLSS and an environment systems respectively; |C|, |S|, |E| =the technological structure its systems; $\bar{C}, \bar{S}, \bar{E}$ =the system functioning regularities; \underline{C} =the purpose of the MMES.

An IRLSS is selected as a baseline for HSCSOS development consists of (Figure 1):

- a System for Water Recovery from Humidity Condensate (WRS-AC) based on sorption/catalytic process to remove of organic and inorganic contaminants from condensate;
- a System for Water Reclamation from Urine (WRS-U) based on the low-tem-premature distillation and sorption/catalytic process for the removal of organic and inorganic contaminants from urine condensate;
- a System for Oxygen Generation (OGS) by water electrolysis from electrolyte solution (the OGS-1 is a virtual simulator and the OGS-2 is an Electrical Trainer (ET) of standard system enabling a number of manual operations);
- a Oxygen Solid Fuel Generator (OSFG) based on sodium perchlorates;
- a Bottle Filling System (BFS) for extra-vehicular activity based on post-purification and compression of oxygen produced by OGS;
- a Trace Contaminant Control System (TCCS) based on sorption/catalytic process for the removal of trace contaminants from the pressurized manned module cabin atmosphere;
- a Carbon Dioxide Removal System (CDRS) based on regenerable absorbent vacuum desorption;
- a Carbon Dioxide Concentration System (CDCS) based on regenerable absorbent vapor desorption;
- a Carbon Dioxide Reduction System (CRS) based on carbon dioxide conversion to methane by hydrogen;
- an Atmosphere Leakage Make-up System (ALMS) by means of nitrogen supply with supply correction based on the oxygen partial pressure value;
- Atmosphere Leakage Tracing System (ALTS).

The individual systems as part of the IRLSS interact via interfaces between the systems and environment. The analysis results of the operational interfaces shows the HSCSOS architecture shall incorporated the environment components such as the atmosphere of the PMM and the crew taking into account specifics of its functioning in interplanetary flight conditions as well as on-board Power Supply System (PSS) and a convective/radiation Thermal Control System (TCS).

The operator's skills which crewmembers shall possess in the critical phases of long self-sustained mission owing to localization of the off-nominal situations (ONS) related the IRLSS functioning imply a high degree of sophistication and may be disturbed under influence of many kinds of stresses. Therefore, when off-normal situation localization simulation is carried out it is necessary to approach it as closely as possible.

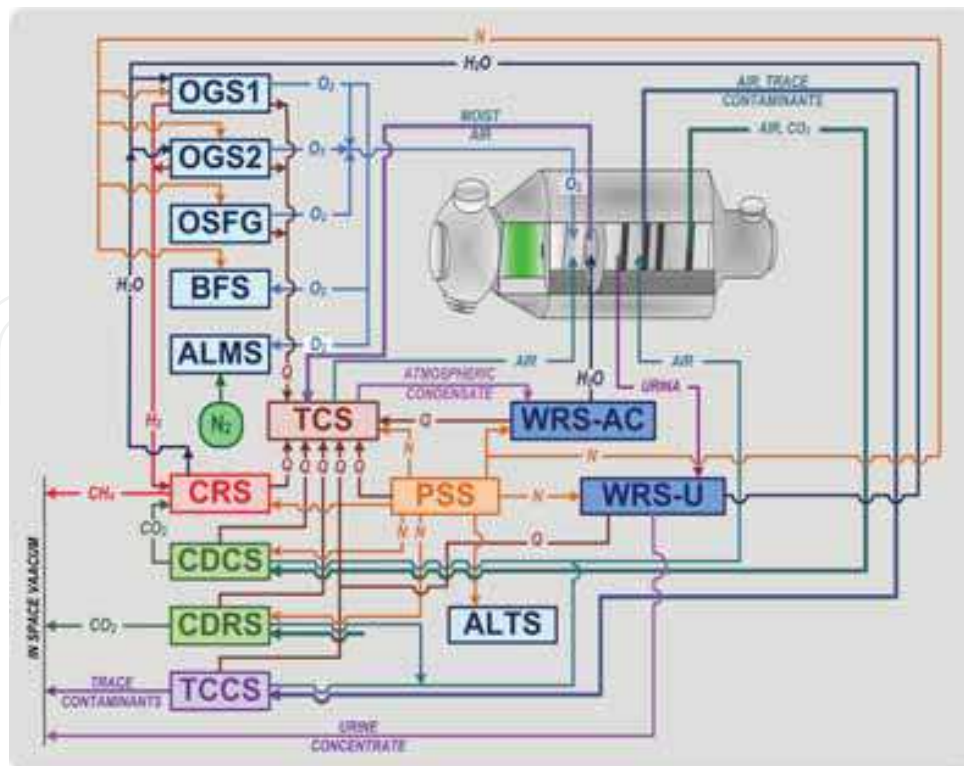

Fig. 1. Integrated Regenerative Life-Support System baseline selected for HSCSOS.

3. Approach to the HSCOCS software development

Approach to the HSCSOS software development is based on the application of the simulation modeling for analysis for the IRLSS system performance in the normal, off-normal and emergency situations, the monitoring of the environmental controllable parameter values and efficient assessment of the crew's actions when off-normal situations are being localized. The simulation model is a logic-mathematical description of the object which may be applied to staging computational experiments in designing, analyzing and assessing object functioning.

Simulation modeling as a specific type of modeling is applied when:

- an experiment upon an actual object is difficult or impossible;
- an analytical model cannot be built (there is cause/effect relationships, how-linearity, stochastic variables);
- time dependent system mode of operation.

The analysis results of the IRLSS performance show that the HSCSOS software architecture shall include the following interacting units (Figure 2):

- IRLSS individual system functioning Virtual Simulators (VS);
- a simulation model of the PMM atmosphere integrating the VSs as a whole and providing the monitoring of crew's environment controllable parameters;
- a crew simulation model as component of environment governing the loads on individual systems;
- procedures for generating probable off-normal situation (ONS) in operation of the IRLSS system, ONS identification and preparation of guidelines and rules for crew in localization of given ONS;

- procedure for crewmember's action efficiency assessment in localization of ONS;
- a specially-created database of monitoring and measurement of crewmember's physiological parameters.

In complex development such as the HSCSOS it is most important for formation of the closed formalized description to select the approaches for generation a closed formalized description of the above specific components of the complex architecture in order to obtain required and sufficient information on system performance analysis in normal and off-normal situations.

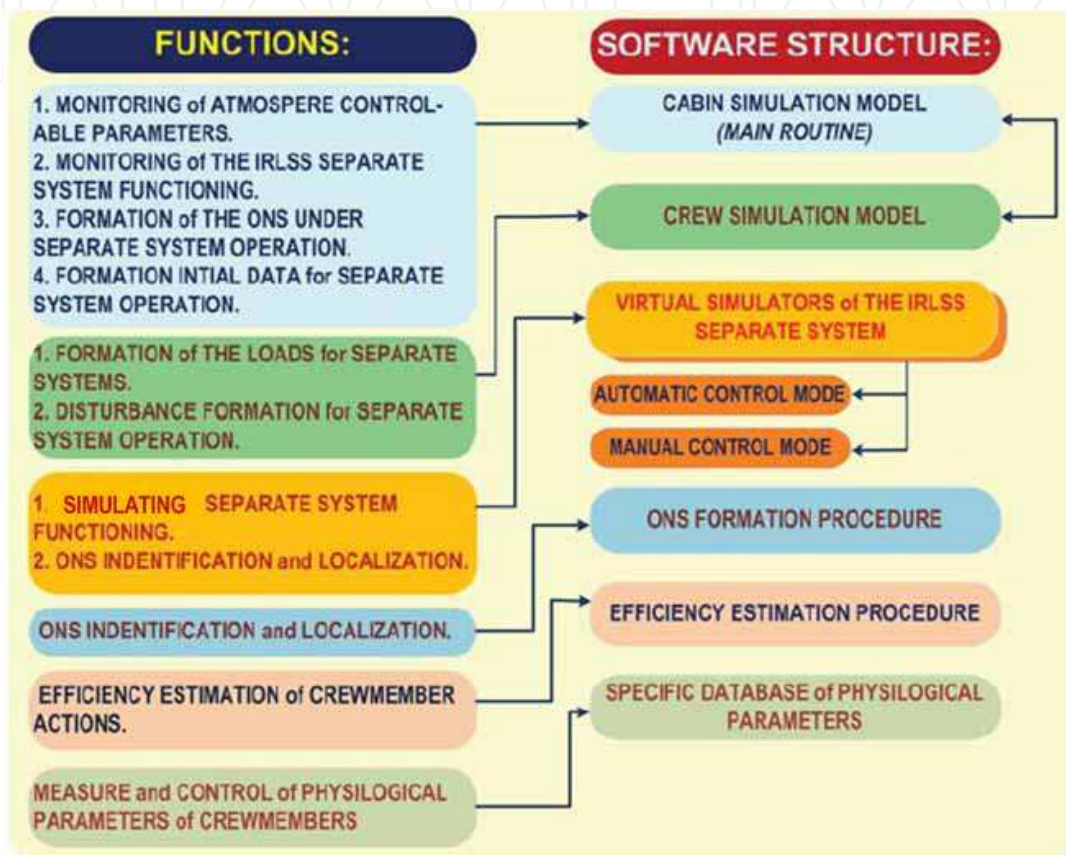

Fig. 2. The architecture and basic functions of the HSCSOS software some components.

3.1 An approach applied to generating formalized descriptions of virtual simulators

Formalized descriptions of individual system virtual simulators based on the detailed level as the aggregate are applied (Kurmazenko E.A. at al., 1997; Kurmazenko E.A. at al., 2008).

In this case an individual system is presented as an aggregate which implies generation of a closed mathematical description including (Figure 3 a):

- the set $\{X\}$ =alphabet of state in parameters;
- the set $\{Y\}$ =alphabet of state output parameters;
- the set $\{Z\}$ =alphabet of state inner parameters;
- the set $\{U\}$ =alphabet of state controlling parameters;
- the set $\{W\}$ =alphabet of outer and inner perturbation actions.

When applying the simulation models the alphabet of in parameters, out parameters and controlling parameters shall be correspond to controllable parameters of the system being simulated. The alphabet of perturbation actions is governed by time-varying controllable

parameter values of the environment with a specific system in operation and crew present in the PMM atmosphere. The inner perturbation actions are mainly governed by controllable parameter values of the system being simulated. In order to formulate the alphabet of inner states an approach based on a functional description of this description is applied.

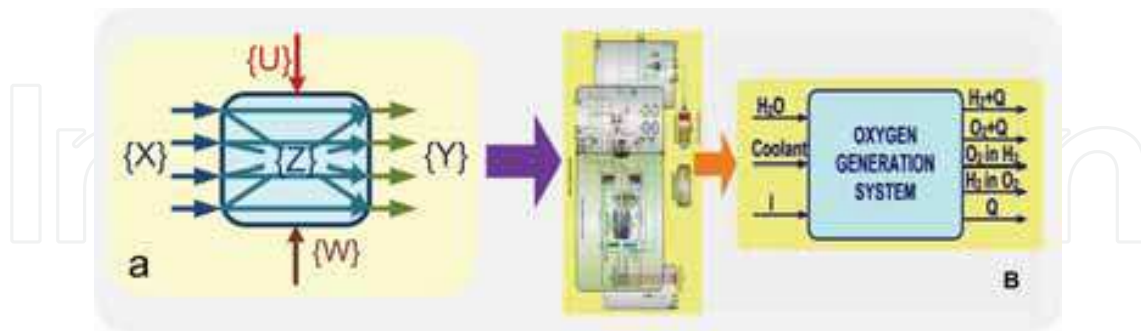

Fig. 3. The system presented as the aggregate: a = design aggregate schematic; b = the OGS presentation as aggregate.

As an example generation of a formalized description of the inner state alphabet for the OGS VS is presented on Figure 3 b. In order to formulate the alphabet of inner states the following basic assumptions are made:

- A formalized description shall take into consideration only values of controllable parameters of inflow and outflow which govern the regulatory and behavior of system functioning;
- thermal/physical properties of electrolyte-produced gas mixtures and coolant over the temperature range investigated are assumed constant;
- owing to a short time of transient process for a current the mass flows of oxygen, hydrogen in oxygen, hydrogen, oxygen in hydrogen and water vapor are described by algebraic equations;
- the main sources of oxygen in hydrogen and hydrogen in oxygen are electrolyzer water supply headers in which an uncontrollable electrolysis process takes place.

With consideration for the given assumptions the formalized description of the inner state alphabet may be presented as:

$$I_{el}^r = I \frac{R_{col}^r}{R_{col}^r + R_{el}^r}; \quad (6)$$

$$U^r = e_a^0 + e_c^0 + a_a + a_c + 0,001(b_a + b_c) \frac{I_{el}^r}{S_{ed}} + I_{el}^r R_{el}^r; \quad (7)$$

$$I_{col} = I - I_{el}; \quad (8)$$

$$G_{O_2(H_2)}^r = \frac{n}{2F} \left[2A_{O_2(H_2)} I_{el}^r + (A_{O_2} + A_{H_2}) I_{col}^r \right]; \quad (9)$$

$$G_{H_2 \rightarrow O_2(O_2 \rightarrow H_2)}^r = \frac{nA_{O_2}(A_{H_2})}{2F}, \quad (10)$$

where: A_{O_2}, A_{H_2} = chemical equivalents of oxygen and hydrogen, kg/mol, respectively; a_a, a_c, b_a, b_c = Tafel's constants for the anode and cathode; e_a^0, e_c^0 = theoretical potentials of the anode and cathode, V for a_a and a_c and Vm^2/A , for b_a and b_c , respectively; F = Faraday constant, Kl/mol; $G_{O_2(H_2)}^r$ = the mass flow-rate of gas being produced in the electrolyzer oxygen (hydrogen) compartment, kg/s; $G_{H_2 \rightarrow O_2(O_2 \rightarrow H_2)}^r$ = the mass flow-rate of oxygen (hydrogen) produced in the hydrogen (oxygen) compartment; I, I_{el}, I_{col} = the total electrolyzer current, current through the electrolytic cell and current in the header, A; n = the quantity of an electrolytic cells; R_{col}^r, R_{el}^r = the electric resistance of the header and electrolyzer, Ohm; S_{ed} = the electrolytic cell surface area, m^2 ; U^r = the electrolyzer voltage, V. The average electrolyzer temperature T_{el} , K, as a function of the supply current I_{el} is determined from regressive dependence

$$T_{el} = f_1(T_{cool}) \left(-0.3305 + 0.0034 I_{el}^2 + 2.085 I_{el}^{0.5} + \frac{21.29}{I_{el}^{0.5}} \right), \quad (11)$$

obtained as a result of processing of the data of a computer experiments conducted by using the OGS detailed simulation model.

The hydrogen (oxygen) moisture content downstream the separator, kg/kg

$$d_{H_2(O_2)}^r = \frac{\left[27.6 + 0.23 (T_{sep}^r - 273)^{1.5} \right] \cdot \mu_{H_2O}}{m_{sep} \cdot \mu_{H_2(O_2)}}, \quad (12)$$

where $\mu_{H_2(O_2)}, \mu_{H_2O}$ = the molar masses of hydrogen (oxygen) and water, kg/mol.

The temperature of the mass flows of hydrogen and oxygen downstream from the separator T_{sep} , K, is determined by regressive dependence as

$$T_{sep} = f_2(T_{cool}) \left(-15.387 + 0.249 I_{el} + \frac{173.184}{I_{el}^{0.5}} + \frac{319.898}{I_{el}} \right). \quad (13)$$

The temperature functions $f_1(T_{cool})$ in the relationship (11) and $f_2(T_{cool})$ in the relationship (13) are determined as

$$f_1(T_{cool}) = \left[1 + 0.82(T_{el} - 273) + 0.03(T_{el} - 273)^2 \right] T_{el}^{-1}; \quad (14)$$

$$f_2(T_{cool}) = \left[1 + 0.9(T_{el} - 273) \right] T_{sep}^{-1}, \quad (15)$$

where T_{cool} = the coolant temperature, K.

The similar approach to generation of formalized descriptions of system functioning is adopted for other virtual simulators.

3.2 Approach used for formation of the PMM atmosphere formalized description

When generation the formalized PMM atmosphere description the following basic assumptions are made (Kurmazenko E.A. at al., 1998):

- the PMM atmosphere is considered as an open thermodynamic system;
- man-made atmosphere is considered as a mixture of ideal gases the heat capacity of which is governed by its chemical composition and temperature-independent;
- trace contaminants due to their low content do not affect the generation of total pressure in the PMM and thermal/physical properties of man-made gaseous atmosphere.

Considering the assumptions made the nonlinear equations of mass balances for the basic components (oxygen, carbon dioxide, nitrogen and water vapor) and trace contaminants as well as the non-linear equation of internal energy balance for the PMM atmosphere reference volume may be written as the equations in deviations:

$$M_{PMMa}(\tau) = \sum_{i=1}^{i=4} M_{PMMi}(\tau); \quad (16)$$

$$M_{PMMi}(\tau) = M_{PMMi}(\tau - \Delta\tau) + \sum_{j=1}^{j=n} (\pm G_{ij} \Delta\tau); \quad (17)$$

$$M_{TC}(\tau) = M_{TC}(\tau - \Delta\tau) + \sum_{k=1}^{k=s} (\pm G_{TCk} \Delta\tau) \quad (18)$$

$$U(\tau) = U(\tau - \Delta\tau) \pm \sum_{l=1}^{l=p} c_{p_l} G_{il} \Delta\tau \pm \sum_{m=1}^{m=t} q_m \Delta\tau \quad (19)$$

In the equations (16)÷(19) the following notation is adopted: $M_{PMMa}, M_{PMMi}, M_{TC}, U$ = the value of atmosphere total mass, i -basic component mass, k -trace contaminant mass, kg, and atmosphere internal energy, J, respectively; G_{ij}, G_{TCk} = i - basic component mass flow-rate and k =trace contaminant mass flow-rate entering and leaving the reference volume, kg/s; q_m = heat flows due to heat conduction entering and leaving the volume under consideration, W; c_{p_i} = the i - basic component specific heat capacity, J/kg °C; $\tau - \Delta\tau, \tau, \Delta\tau$ = previous time, current time and integration step in time, respectively, s.

The current values of mass flow-rates of the atmosphere basic components and trace contaminants upstream and downstream the reference volume as well as heat flows entering and leaving together with mass flows of atmosphere components and heat conduction are determined at each integration step by the current values of the ingoing and outgoing flows with the system performance virtual simulator values.

3.3 Approach used for formation of the 'crew' unit formalized description

When generating a formalized description of the 'crew' unit the following assumptions are made:

- a single crewmember is considered as the structure of interrelated functioning systems in which incoming mass and energy flows are converted into outgoing mass and heat flows, and activity;

- the cosmonaut's energy expenditure when doing various kinds of activity is balanced by caloric value of food ration and total value of energy expenditure;
- potable water is consumed with food;
- the main factor that governs the basic point is the crew's activity defined by the spaceflight program;
- in order to describe mass and heat flows in the 'crew' unit an international model of a conventional human where the mass and heat flows are proportional to energy expenditures (Adamovich B.A., and Gorshenin V.A., 1997). In doing so, the coefficients of this model are corrected based on the results of the computational experiments used the detailed simulation model on the basis which the human organism main functional systems (Figure 4), governing the mass/exchange with the environment are simulated (Kurmazenko E.A. et al., 2000).

The initial data used for generating a formalized description of the 'crew' unit also include an activity/rest cycloramas for every crewmember.

Oxygen consumption G_{O_2} , g/h, is a function of energy expenditure N

$$G_{O_2} = a_0 N, \quad (20)$$

in which coefficient a_0 varies in the range from 0.28 to 0.31, g/kcal.

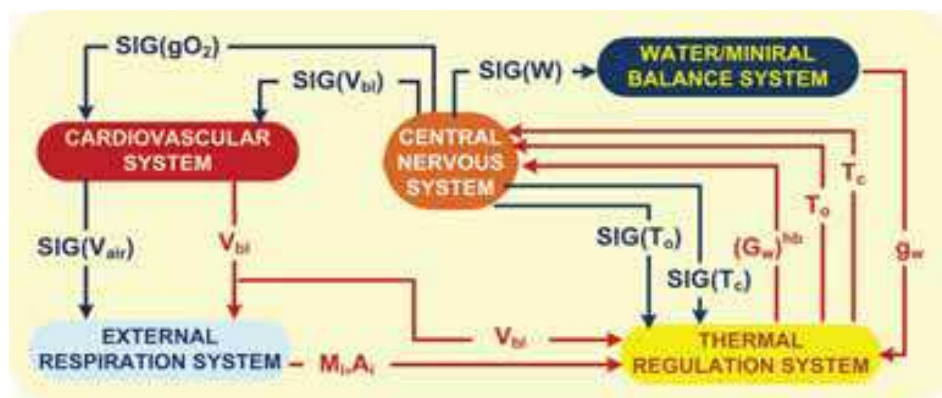

Fig. 4. Enlarged flowchart of human body main functional systems, where: $SIG(gO_2)$, $SIG(V_{bl})$, $SIG(V_{air})$, $SIG(W)$, $SIG(T_0)$, $SIG(T_c)$ = signal functions of the Central Nervous System controlled by the oxygen consumption, blood flow, breath volume, water consumption and Thermal Regulation System in dependence from values of ambient temperature and human's body core temperature, respectively; V_{bl} , M_i , A_i , $(G_w)^{hb}$, g_w , T_0 , T_c = the controllable parameters for signal functions.

Carbon dioxide released G_{CO_2} is a function of energy expenditure N is determined as

$$G_{CO_2} = a_0 K_r N, \quad (21)$$

with the value of the respiratory coefficient K_r is determined from empirical dependence

$$K_r = -0.801 + 0.142 \exp\left(\frac{-96.432}{A}\right). \quad (22)$$

The moisture losses as a result of perspiration and respiration J , g/h, are also of energy expenditure N is determined as

$$J = 91.7 - 0.19N . \quad (23)$$

The quantity of urine donated U , g/h, is a function of energy expenditure N

$$U = 0.19N . \quad (24)$$

Trace contaminant realized TC_i to be considered as a first order approximation are proportional energy expenditure N

$$TC_i = A_i N . \quad (25)$$

In calculation of trace contaminants realized the data presented in work (Savina, V.P., & Kuznetsova, T.I., 1980) are used. The data processed for the mixed ration (50 %-natural food products and 50 % sublimated food products) as a function of the ambient temperature are given in Table 1.

Trace contaminant	Temperature-dependency specific secretion intensity A_i , mg kcal/h for:	
	t=20	20 < t ≤ 40
Ammonia and its compounds	0.0144	0.0144+0.0031t
Ketones	0.0577	0.0577+0.0003t
Carbon monoxide	0.195	0.195+0.0186t
Aldehydes	0.005	0.005+0.0005t
Inorganic acids	0.018	0.018+0.0017t
Total Alcohols	0.012	0.012+0.0005t
Hydrocarbons	0.008	0.008+0.0008t
Methane	0.033	0.033+0.0003t
Acetaldehyde	0.003	0.003+0.0001t
Methanol	0.008	0.008+0.0001t
Ethanol	0.011	0.011+0.001t
Dimethylamine	0.007	0.007+0.0006t
Acetone	0.046	0.046+0.0043t

Table 1. Initial data for simulation of trace contaminant secretion.

4. HSCSOS software implementation

The HSCSOS architecture includes the hardware and software components integrated in a single hardware/software complex.

A general view of the Mars-500 project Ground Experimental Stand (GES) and HSCSOS hardware arrangement are given on Figure 5 and Figure 6, respectively.

The HSCSOS hardware features two work places located in the PMM: Operator's Terminal in PMM-150 (OT1) and Operator's Terminal in PMM-50 (OT2), and the Instructor's Work Place (IWP) located in the Control Experimental Center (CEC).

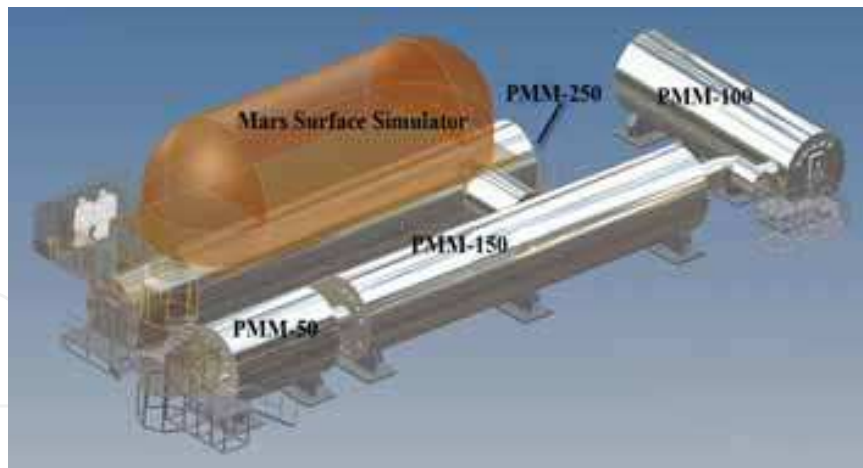

Fig. 5. The general view of the Mars-500 project Ground Experimental Stand.

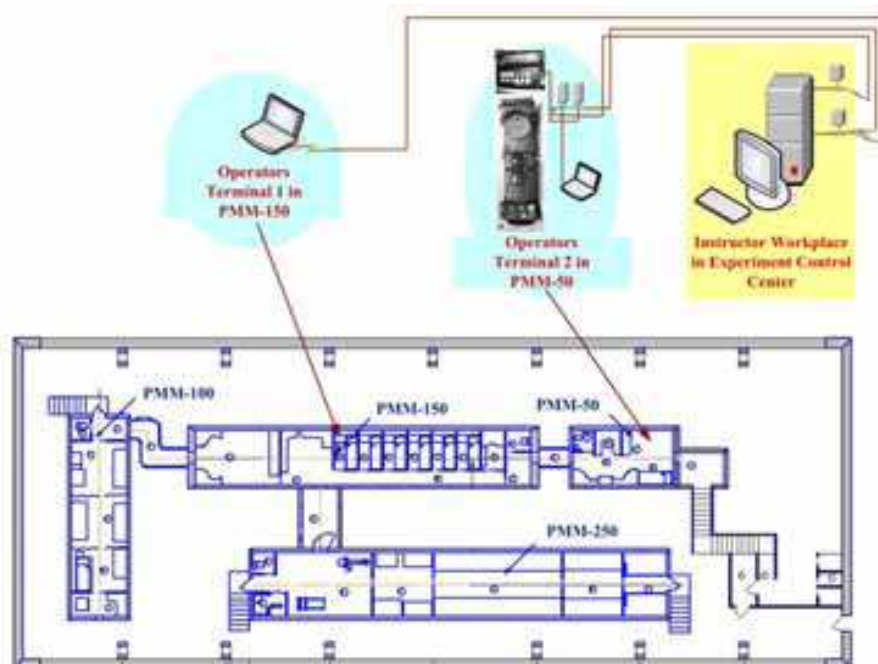

Fig. 6. HSCSOS hardware arrangement at the Mars-500 project Ground Experimental Stand.

According to the HSCSOS architecture the complex software based on 'client -server' technology of data processing and transfer has been developed. The software includes a server and a client sections. The server and client sections are interrelated via specialized technology of data transfer DataSocket integrated in the programming environment LabView, v. 8.5.

The server section contains various calculation modules of 'PMM atmosphere', and 'crew' simulation models, system virtual simulators, off-normal situation generation module, a crew audio warning module, a crew action efficiency assessment module and a protocol module.

The server section provides computations and interrelation with the client section for displaying the parameter values in order to classify the environment and individual system performance and translate control command from client section for correction of system production rates or ONS localization.

The client section displays the data obtained from the server section, generates control signals to transfer them to the server section. In addition, the client section allows the operator to identify and trace ONS develops in the HSCSOS and the time spent to conduct some operations in servicing the systems and localizing ONS. It is not necessary to permanently interconnect the server and client sections. The operator's terminal can be connected in case if the performance requires intervention.

4.1 'PMM atmosphere' simulation model software implementation

The 'PMM atmosphere' simulation model routine is a main program. This simulation model is the basis one to ensure integration of system virtual simulators in the HSCSOS architecture and monitoring of the crew environment parameters (Figure 7).



Fig. 7. Control panel of the 'PMM atmosphere' simulation model, where: t_{oc} , °C, T_{col} , °C, ϕ , %, p_{CO_2} , mm of Hg, p_{O_2} , mm of Hg, p_{Σ} , mm of Hg = controllable parameter values.

The crew's environment parameter values are displayed on the main routine control panel both as values and in color when the parameter value is changed. When the 'TRACE CONTAMINANTS' key is pressed there appears an extra window on the routine control panel to display current trace contaminant concentrations (Figure 8).

In the lower part of the program front panel there are pushbuttons enabling call-in the front panel the corresponding program simulating the functioning of the system when the line appears.

At the bottom of the routine control panel there are call-in keys for control panels of inputs systems simulating system performance. In doing so, color indication 'SYSTEM STATUS CONDITION' appears. Two keys, located below, fully assessable from the instructor's work place and disconnected at the operator's terminal have inscriptions 'ASSIGNMENT OF OFF-NORMAL SITUATIONS' and 'EXPERIMENT SHUTDOWN'.

Experimental verification of the model is carried out on the basis of algorithm assessment for inconsistency, analysis results of computational experiment related to calculation of the balance relationships and ergonomic requirements.

The main routine is interrelated via 'DAY/NIGHT' subroutine which simulates the crew's energy expenditure in the day and night shifts depending on the activity/rest regimens and according to 'Mass Balance' subroutine operation.

The 'Crew' simulation model is experimentally verified based on a correlation between computational experiment resulted (Figure 10) and published specification.

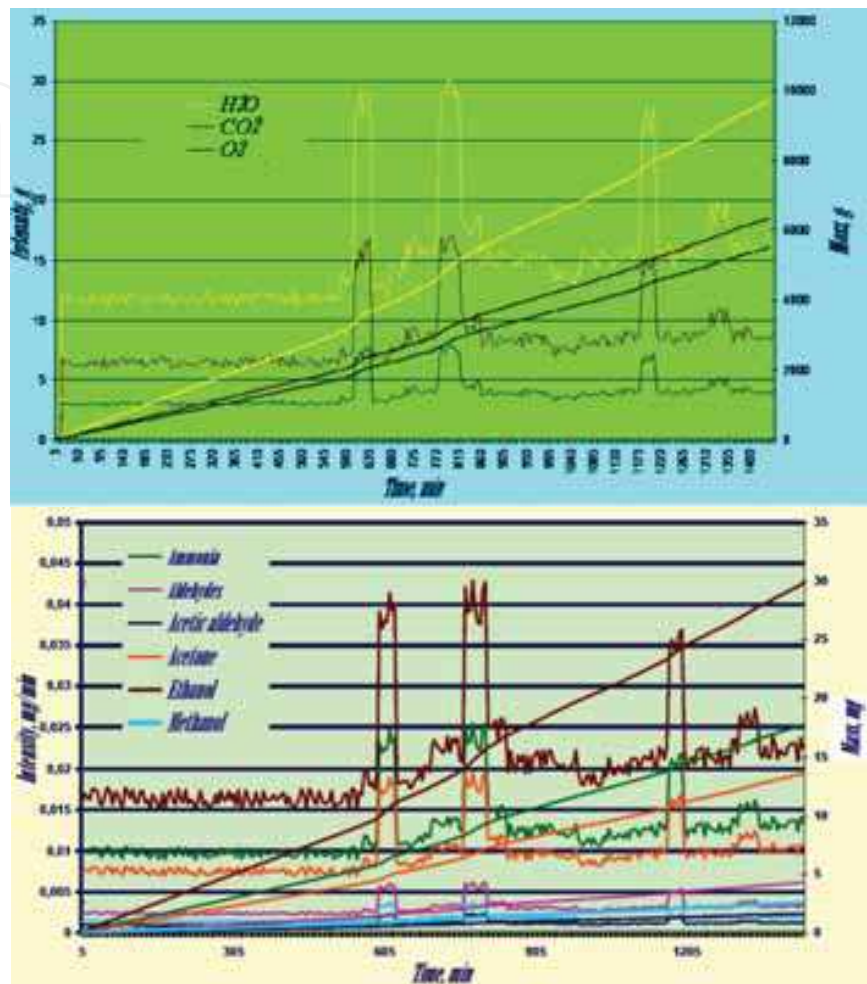

Fig. 10. Typical computational experiment results on 'Crew' simulation model.

4.3 Virtual simulator program implementation

When program implementing virtual simulators of some IRLSS systems its performance data governed by technologies applied they are based on and principles of design execution are adopted as a baseline.

The Air Revitalization and Monitoring Systems (ARMS) are designed to obviate the need to replace units and/or components in prolonged operation. If a unit or a component fails 'cold' or 'hot' redundancy is used to ensure system functioning. Thus, the ONS may be localized without unit replacement.

The systems such as WRS-AC based on sorption/catalytic processes and modular construction require the replacement of some units run out of their lives.

As an example, OGS program implementation as part of the ARMS is considered below (Figure 11).



Fig. 11. Front panel of the ‘OGS’ virtual simulator subroutine in ‘OPERATION NOMINAL MODE’ (НБП/SUP=supply unit pump; КОВ/PWC=pre-purification water container; КЭИ/EVI=electromagnetic valve; МНО/MMP and МНР/RMP=main micro-pump and reserve micro-pump; БХ/СU=cooling unit; БР/SU=separator unit; GA=gas analyzer).

A possible off-normal situation generated at the IWP is illustrated in Figure 12.



Fig. 12. Front panel of the ‘OGS’ virtual simulator subroutine in ‘OPERATION OFF-NOMINAL MODE’ (Pressure in the canister is below norm.).

The line 'CURRENT STATUS' displays 'NORMAL OPERATION' or 'ONS' inscriptions in the upper part of the control panel. The subroutine generates the following signals:

- current system status;
- a combined signal indicating the necessity of maintenance or ONS localization.

When the 'OFF-NORMAL SITUATION' signal is displayed on the control panel of the 'PMM atmosphere' main routine the operator shall switch to the OGS subroutine control panel by pressing the key and jump to ONS localization operations.

As an example of OGS shutdown the ONS by the signal 'PRESSURE IN THE CANISTER BELOW NORM (CNP)' is considered. The 'OFF-NORMAL OPERATION' inscription and 'CNP' inscription on the OGS control panel light up. To localize the ONS the operator shall press the 'ONS LOCALIZATION' key on the OGS control panel.

The canister pressurization panel (Figure 13) opens and the operator carries out all the required operations to pressurize the canister.

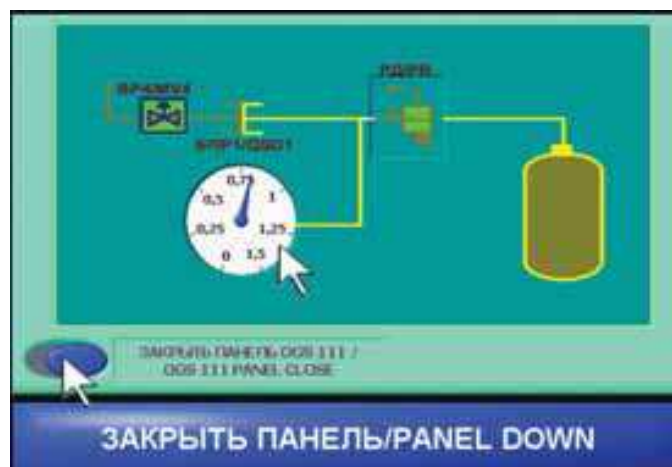

Fig. 13. Control panel of the subroutine 'Canister pressurization'.

Then the operator shall return to the subroutine by pressing 'PANEL DOWN' key. After ONS has been localized the operator shall put the system in operation by pressing the 'SYSTEM START-UP' key and check the startup.

The program implementation of on-board the PMM and TCS systems virtual simulators is accomplished similar to that of the IRLSS system virtual simulators (Figure 14 and Figure 15).



Fig. 14. Control panel of the PSS VS.



Fig. 15. Control panel of the TCS VS.

OGS-2 electrical trainer (ET) program implementation is for inculcating in crewmembers the practical skills in start-up, normal functioning, and shutdown, and in case of off-normal situations.

The ET (Figure 16) consists: an electrical operational breadboard of the liquid unit (LU); a post-purification unit; a signal and command synchronization unit (SCSU); a commutation unit; an Electron-VM monitoring and control unit implemented by an individual subroutine integrated in the HSCSOS software architecture.



Fig. 16. Electrical trainer of the OGS-2 system based on the Electron-VM standard system.

The ET architecture is based on a combination of the simulation model of functioning realized at the IWP, and standard system hardware. A set of existing units incorporated in the ET architecture is used due to availability, and necessity of carrying out manual operations on the standard system hardware. The signals generated by the sensors of the LU electrical breadboard, as well as the signals and commands are simulated on the IWP computer according to a control algorithm, then converted in the communication unit and enter the SCSU unit to be executed by the LU components.

5. Measurement and monitoring of crewmember's psycho-physiological parameters

A medico-engineering system Biomouse (BMEA) is incorporated in the HSCSOS hardware architecture to perform psycho-physiological tests (Figure 17).

The applied procedure for assessing the functional organism state is based on use of calculation analysis of cardiac rhythm parameters. This procedure enables rapid assessment of the influence of cardiovascular system on the basis of cardiac rhythm parameters. The functionality of cardiovascular system and the excitation degree of the vegetative nervous system are calculated (Baevsky, R.M. at al., 1998).



Fig. 17. A general view of the Biomouse medico-engineering system.



Fig. 18. Manipulator of mouse type with the built-in combined sensors: a view from the PPG sensor is shown in the left and a view from GSR and ECR sensors is shown in the right.

The BMEA system consists of a measurement unit and manipulators of mouse type installed on the OT1 and OT2 with the built-in combined sensors allowing simultaneously and continuously to register three physiological parameters (Figure 18): photo-plethysmogram (PPG), galvanic skin reflex (GSR) and electro-coetaneous resistance (ECR).

The estimation of a crewmember's psycho-physiological condition prior to the beginning of activities and on the termination of activities on localization ONS was conducted in tests mentioned below (ZAO "Neurolab", 2008):

- *Variation hronokardiometriya (WRC)* is method of rapid assessment of the cardio-interval-grams cardiovascular system regulatory mechanisms. Calculated level of the cardiovascular system functionality and autonomic homeostasis, in addition, recorded: maximum, minimum and average values, as well as fashion, mode amplitude, standard

deviation and magnitude of the sequence of cardio. Primary information is photoplethysmogram (a signal from an optical infrared sensor in a digital form). From this signal is allocated an array of cardio intervals, which is subjected to statistical processing.

- *Complex visual-motor reaction (CVMR)* is designed to study the functional state of central nervous system and elements of the operator's attention to human efficiency. The test is based on a study of the statistical characteristics of distribution of the set reaction time. On the screen appear consistently distinguished by the color of light stimuli - circles red or green, the test subject must quickly put out by pressing the right or left mouse button. Recorded response time and response error (omission, premature depression, abnormal response). The following parameters are calculated: the average response time, standard deviation, the number of errors of each type. Based on the statistical parameters of the algorithm on the attached class state of the operator's central nervous system for two-dimensional scale is calculated.
- *Reaction to a moving object (MOR)* is the test to evaluate balance of excitation and inhibition in the nervous system, as well as functional changes under the influence of the load. In this test, the test subject must stop the moving hour hand as close to 12 o'clock by using the Space key.
- *Mirror coordinograph (MC)* is designed to determine the level of stress stability of the test subject. In this test, the operator must use mouse to quickly pass a curved path on the screen without touching its edges. Time and the fact of the contour, the number of touches and time are recorded. These parameters determine the quality of the operator's actions. In addition, before and after the passage of the contour levels are recorded and the mean pacing heart rate. Changes of these parameters are interpreted as the 'value' of the operator. Performance assessment is based on two criteria: 'value' and 'quality'. 'Quality' is composed of indicators such as time of the circuit, the number of touches, while touches.

The BHEA software integrated in the HSCSOS server section software at the IWP is presented by specific database, which executes the following functions:

- storage of a database surveyed crewmembers;
- formation of a set of tests for examination;
- processing results of examination and storage of results in an archival file.

6. HSCSOS operational use in 105-day experiment under Mars-500 project

The main purpose of research is an estimation of efficiency of servicing by the crew of the IRLSS systems. The following problems should be solved for achievement of the given purpose:

- estimation of sufficiency of the controllable parameters list for the analysis of functioning and servicing on the basis of use of the HSCSOS and an electrical trainer of the Electron-VM integrated in complex in conditions of long autonomous mission;
- estimation of efficiency of activity of the operator on localization of the off-nominal situations arising at functioning of systems and/or deviations of the environment controllable parameter values from prescribed values;
- estimation of efficiency of acceptance of independent solutions by crewmembers in the ONS localization;

- estimation of efficiency of ways of display of the information on values of the environment controllable parameters in analysis of functioning and servicing with the use of virtual simulators of systems;
- estimation of the ONS localization influence on the mental and physiological state of crewmembers in conditions of long-term autonomous mission.

6.1 Technique of an experiment

In realization of initial phase, being the final stage of the crew training makes tentative estimation of the crewmember action efficiency in the ONS localization. Formation of the particular situation arising in the IRLSS specific system operation is made on the basis of random sample by the Instructor.

Localization of the arisen ONS is made by each crewmember with the use of the on-board instruction from the operator's workplace disposed in the Main Control Board. In this case both a rigid copy of the on-board instruction, and its electronic version which is available in a format *.PDF on Operator's Terminal 1 and Operator's Terminal 2, can be used without Mission Control Center recommendations.

Generated off-normal situations are characterized by different degrees of complexity in their localization:

- simple (service of a complex, localization of some ONS, not demanding replacements of units, etc.);
- average complexity (the most part of ONS entered demanded the replacement of units);
- complicated (actuate crewmember's activity with the Electron-VM electrical trainer, and also ONS, demanding a long-period operation on elimination or monitoring (imitation of a fire or leakages).

For assessment of the crewmember gained efficiency the following is considered:

- complexity of necessary camera skills depending on the solved problem of ONS localization;
- time of reaction on ONS being in parameter time-dependent day of the ONS occurrence and from congestion of crew other problems;
- attentiveness of crew during ONS localization;
- time spent for ONS localization;
- total amount of the activities considering total of solved tasks including monitoring of system operation, activity with an electrical simulator and realization of maintenance;
- dynamics of activity formation.

The increased duration of localization of failure indicates absence of attention concentration in some crewmembers that is connected or with realization of some additional activities, either with fatigue, or with presence of distracting factors.

6.2 Results of experiment

During experiment 52 tasks in total (including activity with the Electron-VM electrical trainer) are generated. 51 tasks are successfully solved. Views generated of the ONS and times expended on its localization are given in Table 2. Results of the crewmember action efficiency estimation in the ONS localization are presented in Table 3.

The typical results of experiments are shown on Figure 19 and Figure 20.

ONS localized	Time spent by a crewmember on ONS localization, min						Total time, min	Average time, min
	1001	1002	1003	1004	1005	1006		
TCCS ONS:								
Failure of fan		2		12		12	26	6.5
Failure of electroheater		5	14		10	2	33	6.6
Failure of valve	2			5			7	3.5
CDRS ONS:								
Failure of fan	2	4	2	7		3	18	2.8
Failure of valve			6	1		5	12	4
WRS-AC ONS:								
Failure of pump		4	11	5	5	8	33	4.7
OGS-1 ONS:								
ONS 'CURRENT < 2 A'	5	11					16	8
ONS 'PRESSURE in CAPSULE < NORM'			3				3	3
Failure of pump						2	2	2
ONS 'ELECTROLYZER TEMPERATURE < NORM'					4	8	12	6
TCS ONS:								
Failure of pump		11	8				19	9.5
Failure of fan		2		4	5	3	14	3.5
Failure of valve		6		3		9	18	6

Table 2. ONS types generated and times expended on its localization.

CREWMEMBER	ESTIMATION of CREWMEMBER'S ACTION EFFICIENCY														
	IN TOTAL ONS LOCALIZATION	TOTAL of DIFFICULT TASKS FROM ITS SOLVED	TOTAL of AVERAGE COMPLEXITY FROM ITS SOLVED	TOTAL of SIMPLE TASKS FROM ITS SOLVED	ANALYSIS of SYSTEM OPERATION	USE of ONBOARD INSTRUCTION under INDEPENDENT ACTIONS	ONBOARD INSTRUCTION CORRECTION	USE of EXTERNAL HELP under INDEPENDENT ACTIONS	ATTENTIVENESS under ACTIONS	REACTION under ACTIONS	AVERAGE TIME for ONS LOCALIZATION of AVERAGE COMPLEXITY, min	AVERAGE TIME for ONS LOCALIZATION of LOW COMPLEXITY, min			
1001	6	1	0	1	1	1	1	0	2	0	2	2.5	1	4	1
1002	11	2	1	8	8	1	1	1	2	1	2	2	1	5.5	3
1003	10	1	0	7	7	2	2	0	1	0	1	1.5	1	5.6	5
1004	11	1	0	7	7	3	3	0	1	0	1	2.5	1	4.3	2.3
1005	5	0	0	5	5	0	0	0	1	0	1	1.5	1	4.6	0
1006	11	0	0	7	7	1	1	0	1	0	1	2	1	5.1	3.8

Table 3. Results of the crewmember action efficiency estimation at ONS localization.

With a task of elimination of leakages in the PMM illuminators conducted from 06.29.09 to 07.08.09, the crew has failed. The reason is easing of attentiveness and fatigue of crew at the final stage of the experiment.

Commissioning of Electron-VM electrical trainer has been successfully conducted by the 06.25.09, operator 1002.

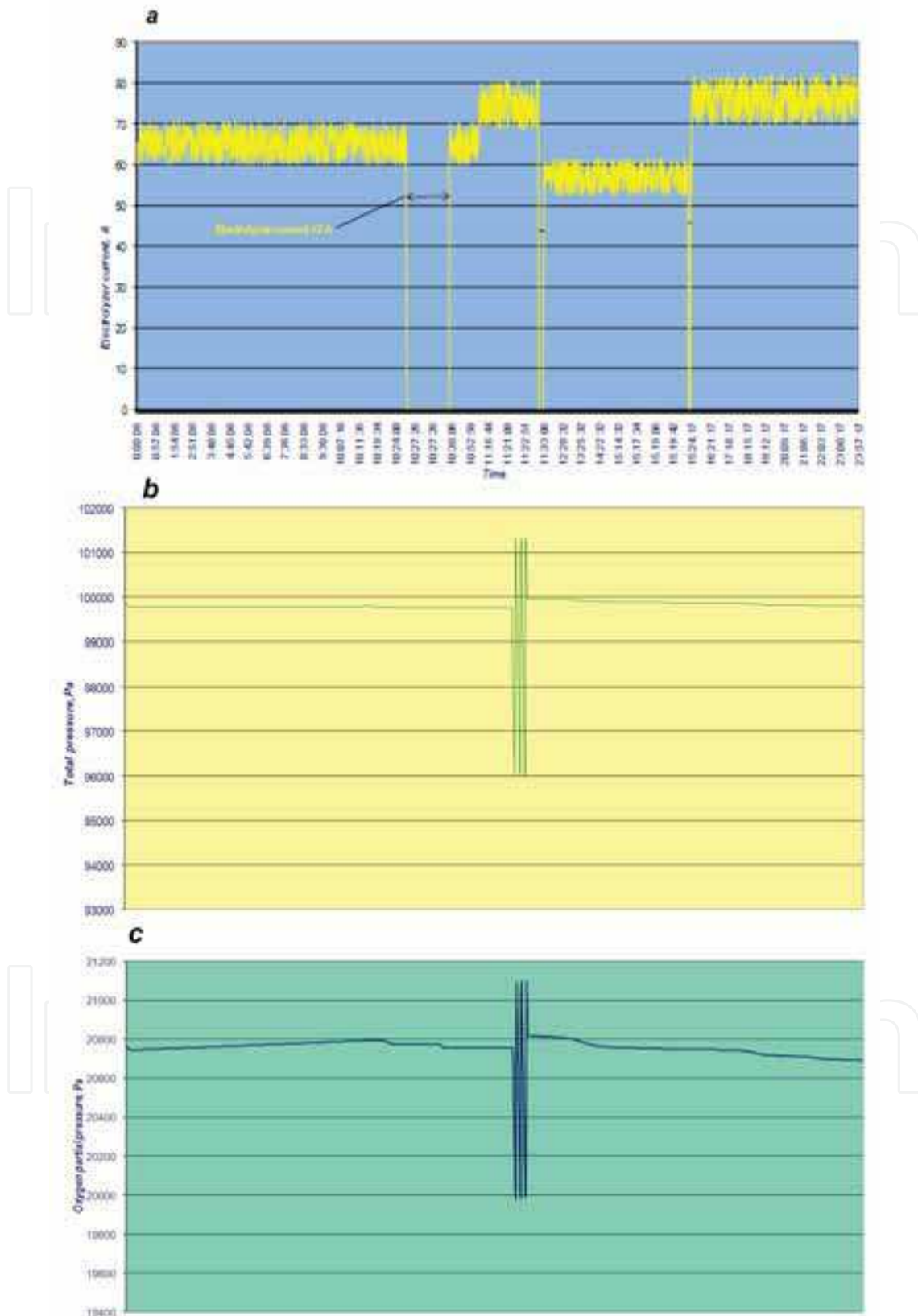

Fig. 19. Localization of the ONS 'ELECTROLYZER CURRENT < 2 A' (Crewmember 1002):
 a - electrolyzer current change; b - total pressure change; c - oxygen partial pressure change.

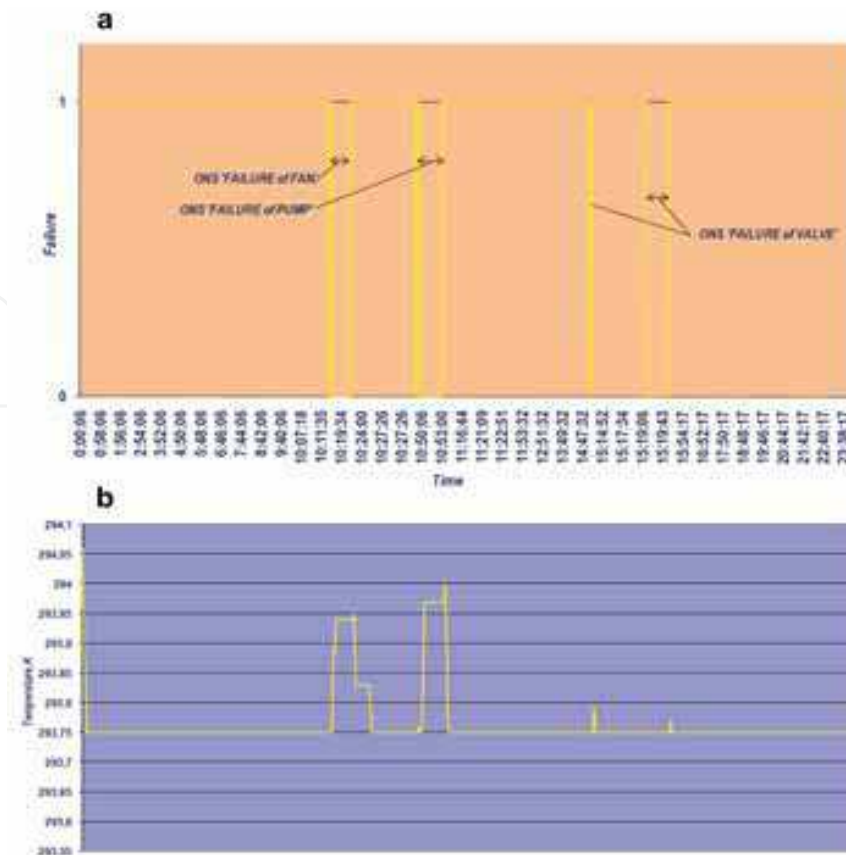

Fig. 20. Localization of the ONS in TCS (Crewmembers: 1005, 1006, 1001): a – failures; b – change of temperature in the PPM.

7. Conclusion

In the chapter the approach to analysis of interaction in the Man-IRLSS system relating to a complex man-machine system, in which human-operator interacts with a technical device during production of environment components, management, processing information, etc is considered.

The offered approach is advanced for the ground medical/engineering experiment imitating interplanetary flight to Mars at which use of standard aboard regeneration life support systems is complicated and is economically unprofitable.

The HSCSOs application has allowed solving the following primary problems:

- to conduct an estimation of crewmember action efficiency at service of the IRLSS and at ONS localization caused by probable failures in its functioning and deviations of the environment controllable parameters from preset values in view of a degree of readiness of crewmembers and conditions of long isolation;
- to research interactions in the IRLSS-Crew system in real time with the purpose of the medical/engineering and ergonomic requirements to IRLSS systems.

Including of standard systems in the HSCSOS architecture is effected by replacement of corresponding virtual simulators with standard systems. As this takes place information channels to and from systems are locked in corresponding logic devices controlling directly actual hardware. Data exchange procedure between specific virtual systems corresponds to a logic structure of flow exchange between actual systems therefore replacement of virtual systems with actual ones will not be problematic.

The considered approaches to research of the IRLSS virtual simulators can be used at development of 'man - machine' for other particular mission.

8. Acknowledgment

Authors express thanks to the colleagues from Joint-Stock Company 'NIIchimash' Lev Gavrilov, Aleksey Kochetkov, Victor Andreev and Roman Sachkov, as well as the our colleagues from SRC RF - IMBP RAN Yuriy Sinyak and Vladimir Trikolkin in many respects promoting fulfillment of the given charter.

Authors are grateful to the reviewer of this chapter Aleksandar Lazinica from CEO for valuable comments made at its preparation.

9. References

- Adamovich, B. A., & Gorshenin, V. B. (1997). *Life outside of the Earth*. Moscow, Science.
- Baevsky, R.M., Kirillov, O.I., & Kletskin, S.Z. (1984). *The mathematical analysis of changes of a cordial rhythm at stress*. Moscow, Science.
- Kurmazenko, E.A., Samsonov, N.M., Farafonov N.S., & Dokunin I.V (1997). *Simulation Subsystem Models for Analysis of the Integrated Regenerative Life Support Systems Functioning*. Proceeding of 6th European Symposium on Space Environmental Systems, Noordwijk, the Netherlands.
- Kurmazenko, E.A., Gavrilov, L.I., Samsonov, N.M. Dokunin, I.V., Romanov S.Ju., & Ryabkin, A.M. (1998) *A Man-Made Gas Atmosphere Simulation Model of International Space Station's Russian Segment*. SAE Technical Paper Series #981718.
- Kurmazenko, E.A., Samsonov, N.M., Farafonov, N.S., Gavrilov, L.I., Dokunin I.V., & Kotelnikova, M.A. (2000). *Crew software simulation for Integrated Life Support System Operation Study*. SAE Technical Paper Series #2000-2120.
- Kurmazenko, E.A., Gavrilov, L.I., Kochetkov, A.A., Khabarovskiy, N.N. Demin, E.P., Grigorjev A.I, & Baranov V.N. (2008). *Life Support System Virtual Simulators for Mars-500 Ground-Based Experiment*. Proceeding of 59th International Astronautical Congress, Glasgow, Scotland.
- Kurmazenko, E.A., Gavrilov, L.I., Kochetkov, A.A., & Khabarovskiy, N.N. (2009). *Space Ecological/Engineering System for the Manned Interplanetary Vehicles Crew: Status and Key Technologies for its Development*. Proceeding of the 60th International Astronautical Congress, Daejeon, Republic of Korea.
- Kurmazenko, E.A., Kochetkov, A.A., Gavrilov, L.I., Khabarovskiy, N.N., Kamaletdinova, G.R., Morukov, B.V., Demin, E.P., & Trikolkin, V.I (2010). *Crew's Service of the Virtual Integrated Regenerative Life-Support System Operation: 105-Day Experiment Results under Mars-500 Project*. AIAA Technical Paper Series #2010-6168.
- Pravetskiy, V.N., Samsonov, V.M., Utyamyshev, R.I., & Kurmazenko, E.A. (1981). *Separate Problems of the Life-Support and Safety System Development for a Spaceflight Vehicle Crew*. Scientific Reading on Aircraft and Astronautics 1980. Moscow, Science.
- Savina, V.P., & Kuznetsova, T.I. (1980) *Trace contaminant sources and their toxicological evaluation*. Space Biology, v. 42, Moscow, Science.
- User guide complex BioMouse CPP and CPP-01-01b (options "Professional" and "Research "), introducing the principles of operation of the product with the functions of the software, and implemented methods* (2008). Moscow, ZAO "Neurolab", www.neurolab.ru

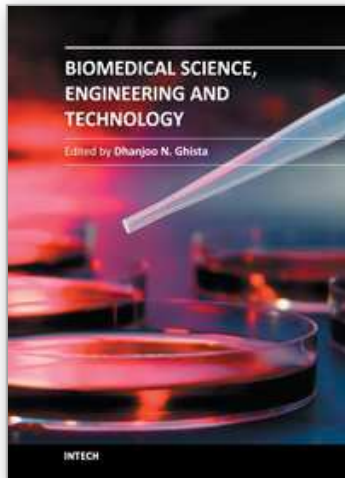

Biomedical Science, Engineering and Technology

Edited by Prof. Dhanjoo N. Ghista

ISBN 978-953-307-471-9

Hard cover, 902 pages

Publisher InTech

Published online 20, January, 2012

Published in print edition January, 2012

This innovative book integrates the disciplines of biomedical science, biomedical engineering, biotechnology, physiological engineering, and hospital management technology. Herein, Biomedical science covers topics on disease pathways, models and treatment mechanisms, and the roles of red palm oil and phytochemical plants in reducing HIV and diabetes complications by enhancing antioxidant activity. Biomedical engineering covers topics of biomaterials (biodegradable polymers and magnetic nanomaterials), coronary stents, contact lenses, modelling of flows through tubes of varying cross-section, heart rate variability analysis of diabetic neuropathy, and EEG analysis in brain function assessment. Biotechnology covers the topics of hydrophobic interaction chromatography, protein scaffolds engineering, liposomes for construction of vaccines, induced pluripotent stem cells to fix genetic diseases by regenerative approaches, polymeric drug conjugates for improving the efficacy of anticancer drugs, and genetic modification of animals for agricultural use. Physiological engineering deals with mathematical modelling of physiological (cardiac, lung ventilation, glucose regulation) systems and formulation of indices for medical assessment (such as cardiac contractility, lung disease status, and diabetes risk). Finally, Hospital management science and technology involves the application of both biomedical engineering and industrial engineering for cost-effective operation of a hospital.

How to reference

In order to correctly reference this scholarly work, feel free to copy and paste the following:

Eduard Kurmazenko, Nikolay Khabarovskiy, Guzel Kamaletdinova, Evgeniy Demin and Boris Morukov (2012). Life Support System Virtual Simulators for Mars-500 Ground-Based Experiment, Biomedical Science, Engineering and Technology, Prof. Dhanjoo N. Ghista (Ed.), ISBN: 978-953-307-471-9, InTech, Available from: <http://www.intechopen.com/books/biomedical-science-engineering-and-technology/life-support-system-virtual-simulators-for-mars-500-ground-based-experiment>

INTECH
open science | open minds

InTech Europe

University Campus STeP Ri
Slavka Krautzeka 83/A
51000 Rijeka, Croatia
Phone: +385 (51) 770 447
Fax: +385 (51) 686 166

InTech China

Unit 405, Office Block, Hotel Equatorial Shanghai
No.65, Yan An Road (West), Shanghai, 200040, China
中国上海市延安西路65号上海国际贵都大饭店办公楼405单元
Phone: +86-21-62489820
Fax: +86-21-62489821

www.intechopen.com

www.intechopen.com

IntechOpen

IntechOpen

© 2012 The Author(s). Licensee IntechOpen. This is an open access article distributed under the terms of the [Creative Commons Attribution 3.0 License](#), which permits unrestricted use, distribution, and reproduction in any medium, provided the original work is properly cited.

IntechOpen

IntechOpen