

# We are IntechOpen, the world's leading publisher of Open Access books Built by scientists, for scientists

**4,800**

Open access books available

**122,000**

International authors and editors

**135M**

Downloads

Our authors are among the

**154**

Countries delivered to

**TOP 1%**

most cited scientists

**12.2%**

Contributors from top 500 universities



**WEB OF SCIENCE™**

Selection of our books indexed in the Book Citation Index  
in Web of Science™ Core Collection (BKCI)

Interested in publishing with us?  
Contact [book.department@intechopen.com](mailto:book.department@intechopen.com)

Numbers displayed above are based on latest data collected.

For more information visit [www.intechopen.com](http://www.intechopen.com)



# Development of Hybrid Method for the Modeling of Evaporation and Evapotranspiration

Sungwon Kim  
Dongyang University,  
Republic of Korea

## 1. Introduction

Evaporation is the process whereby liquid water is converted to water vapor and removed from the evaporating surface. In hydrological practice, the estimation of evaporation can be achieved by direct or indirect methods. Direct method is based on the field measurements. Evaporation pan have also been used and compared to estimate evaporation by researchers (Choudhury, 1999; McKenzie and Craig, 2001; Vallet-Coulomb et al., 2001). The Class A evaporation pan is one of the most widely used instruments for the measurements of evaporation from a free water surface. The pan evaporation (PE) is widely used to estimate the evaporation of lakes and reservoirs (Finch, 2001). Many researchers have tried to estimate the evaporation through the indirect methods using the climatic variables, but some of these techniques require the data which cannot be easily obtained (Rosenberry et al., 2007).

Evapotranspiration (ET) is the sum of volume of water used by vegetation, evaporated from the soil, and intercepted precipitation (Singh, 1988). ET plays an important role in our environment at global, regional, and local scales. ET is observed using a lysimeter directly or can be calculated using the water balance method or the climatic variables indirectly. Because the measurements of ET using a lysimeter directly, however, requires much unnecessary time and needs correct and careful experience, it is not always possible in field measurements. Thus, an empirical approach based on the climatic variables is generally used to calculate ET (Penman, 1948; Allen et al., 1989). In the early 1970s, the Food and Agricultural Organization of the United Nations (FAO), Rome, developed practical procedures to calculate the crop water requirements (Doorenbos & Pruitt, 1977), which have become the widely accepted standard for irrigation studies. A common practice for estimating ET from a well-watered agricultural crop is to calculate the reference crop ET such as the grass reference ET ( $ET_o$ ) or the alfalfa reference ET ( $ET_r$ ) from a standard surface and to apply an appropriate empirical crop coefficient, which accounts for the difference between the standard surface and the crop ET.

Recently, the outstanding results using the neural networks model in the fields of PE and ET modeling have been obtained (Bruton et al., 2000; Sudheer et al., 2003; Trajkovic et al., 2003; Trajkovic, 2005; Keskin and Terzi, 2006; Kisi, 2006; Kisi, 2007; Zanetti et al., 2007; Jain et al., 2008; Kumar et al., 2008; Landaras et al., 2008; Kisi, 2009; Kumar et al., 2009; Tabari et al.,

2009; Chang et al., 2010; Guven and Kisi, 2011). Sudheer et al. (2002) investigated the prediction of Class A PE using the neural networks model. They used the neural networks model for the evaporation process using proper combinations of the observed climate variables such as temperature, relative humidity, sunshine duration, and wind speed for the neural networks model. Shiri and Kisi (2011) investigated the ability of genetic programming (GP) to improve the accuracy of daily evaporation estimation. They used proper combinations of air temperature, sunshine hours, wind speed, relative humidity, and solar radiation for GP. Kumar et al. (2002) developed the neural networks models to calculate the daily ET. They used proper combinations of the observed climatic variables such as solar radiation, temperature, relative humidity, and wind speed for the neural networks models. Kisi & Ozturk (2007) used the neuro-fuzzy models to calculate FAO-56 PM  $ET_o$  using the observed climatic variables. They used proper combinations of the observed climatic variables such as air temperature, solar radiation, wind speed, and relative humidity for the neuro-fuzzy models. Kim & Kim (2008) developed the neural networks model embedding the genetic algorithm for the modeling of the daily PE and  $ET_r$  simultaneously, and constructed the optimal neural networks model using the uncertainty analysis of the input layer nodes/variables. Furthermore, they suggested the 2-dimensional and 3-dimensional maps for PE and  $ET_r$  to provide the reference data for irrigation and drainage system, Republic of Korea. And, the recent researches combining the stochastic models and the neural networks models in the fields of hydrology and water resources have been accomplished. Mishra et al. (2007) developed a hybrid model, which combined a linear stochastic model and a nonlinear neural networks model, for drought forecasting. Kim (2011) investigated the modeling of the monthly PE and  $ET_r$  simultaneously using the specific method, which combined the stochastic model with the neural networks models.

The purpose of this study is to develop the hybrid method for the modeling of the monthly PE and FAO-56 PM  $ET_o$  simultaneously. The hybrid method represents the combination of Univariate Seasonal periodic autoregressive moving average (PARMA) model and support vector machine neural networks model (SVM-NNM). For this research, first, the stochastic model, Univariate Seasonal PARMA(1,1) model, is used for the generation of the reliable data, which are considered as the training dataset. Therefore, the observed data are considered as the testing dataset. Second, the neural networks model, SVM-NNM, is used for the modeling of the monthly PE and FAO-56 PM  $ET_o$  simultaneously. Homogeneity evaluation using the One-way ANOVA and Mann-Whitney  $U$  test, furthermore, is carried out for the observed and calculated PE and FAO-56 PM  $ET_o$  data. And, the correlation relationship between the observed PE and FAO-56 PM  $ET_o$  data can be derived using the bivariate linear regression analysis model (BLRAM), respectively.

## 2. Calculation of FAO-56 PM $ET_o$

Penman (1948) combination method links evaporation dynamics with the flux of net radiation and aerodynamic transport characteristics of the natural surface. Based on the observations that latent heat transfer in plant stem is influenced not only by these abiotic factors, Monteith (1965) introduced a surface conductance term that accounted for the response of leaf stomata to its hydrologic environment. This modified form of the Penman-Monteith (PM)  $ET_o$  model. Jensen et al. (1990) measured  $ET_o$  using the lysimeters at 11 stations located in the different climatic zones of various regions around the world. They

compared the results of the lysimeters with those of 20 different empirical equations and methodologies for  $ET_0$  measurements. It was found that PM  $ET_0$  model showed the optimal results over all the climatic zones. If the observed/measured data for  $ET_0$  does not exist, therefore, PM  $ET_0$  model can be considered as a standard methodology to calculate  $ET_0$ . In Gwangju and Haenam stations which were selected for this study, there are no observed data for  $ET_0$  using a lysimeter. The data calculated using PM  $ET_0$  model can be assumed as the observed  $ET_0$ , whose reliability was verified by many previous studies. All calculation procedures as used in PM  $ET_0$  model are based on the FAO guidelines as laid down in the publication No. 56 of the Irrigation and Drainage Series of FAO "Crop Evapotranspiration-Guidelines for Computing Crop Water Requirements" (1998). Therefore, FAO-56 PM  $ET_0$  equation means PM  $ET_0$  equation suggested by the Irrigation and Drainage Paper No. 56, FAO. FAO-56 PM  $ET_0$  equation is given by Allen et al. (1998) and can be shown as the following equation (1).

$$FAO-56 PM ET_0 = \frac{0.408\Delta(R_n - G) + \gamma(900/(T + 273))u_2(e_s - e_a)}{\Delta + \gamma(1 + 0.34u_2)} \quad (1)$$

where FAO-56 PM  $ET_0$  = the grass reference evapotranspiration (mm/day);  $R_n$  = the net radiation at the crop surface ( $MJ/m^2$  day);  $G$  = the soil heat flux density ( $MJ/m^2$  day);  $T$  = the mean air temperature at 2m height ( $^{\circ}C$ );  $u_2$  = the wind speed at 2m height (m/sec);  $e_s$  = the saturation vapor pressure (kPa);  $e_a$  = the actual vapor pressure (kPa);  $e_s - e_a$  = the saturation vapor pressure deficit (kPa);  $\Delta$  = the slope vapor pressure curve (kPa/ $^{\circ}C$ ); and  $\gamma$  = the psychrometric constant (kPa/ $^{\circ}C$ ). FAO CROPWAT 8.0 computer program has been used to calculate FAO-56 PM  $ET_0$  and extraterrestrial radiation ( $R_a$ ). FAO CROPWAT 8.0 computer program allows the user to enter the climatic data available including maximum temperature ( $T_{max}$ ), minimum temperature ( $T_{min}$ ), mean relative humidity ( $RH_{mean}$ ), mean wind speed ( $WS_{mean}$ ), and sunshine duration (SD) for calculating FAO-56 PM  $ET_0$ . On the base of climatic data available, FAO CROPWAT 8.0 computer program calculates the solar radiation reaching soil surface. Fig. 1(a)-(b) show the calculation of FAO-56 PM  $ET_0$  using FAO CROPWAT 8.0 computer program in Gwangju and Haenam stations, respectively.

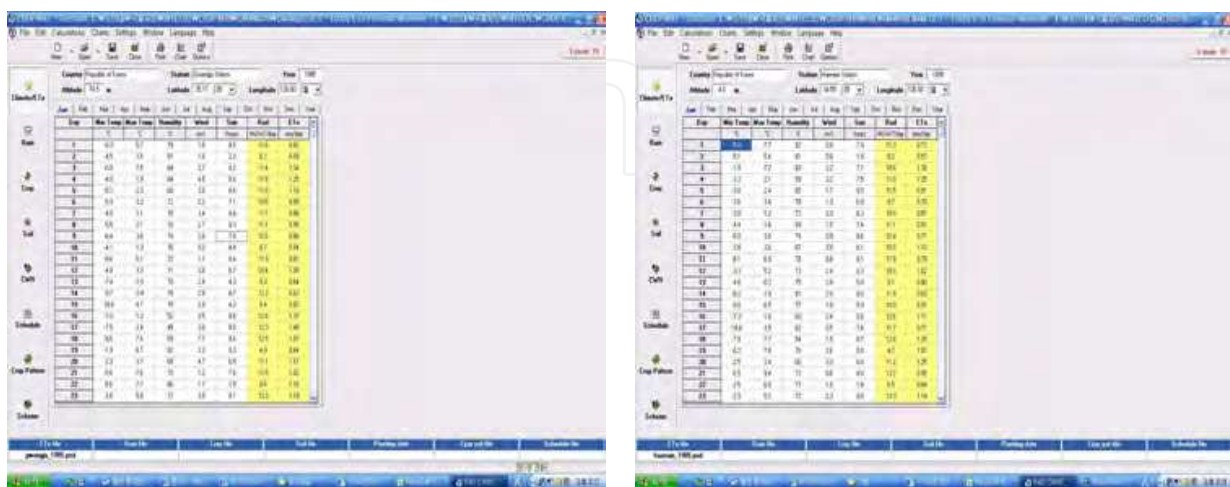

(a) Gwangju

(b) Haenam

Fig. 1. Calculation of FAO-56 PM  $ET_0$  using FAO CROPWAT 8.0 Computer Program

### 3. Stochastic model

#### 3.1 Univariate seasonal periodic autoregressive moving average model

Stationary ARMA models have been widely applied in stochastic hydrology for modeling of annual time series where the mean, variance, and the correlation structure do not depend on time. For seasonal hydrologic time series, such as monthly series, seasonal statistics including the mean and standard deviation may be reproduced by a stationary ARMA model by means of standardizing the underlying seasonal series. Hydrologic time series such as monthly streamflows, PE, and FAO-56 PM  $ET_o$  are usually characterized by different dependence structure depending on the season (Salas, 1993). One may extend Univariate Seasonal periodic autoregressive (PAR) model to include periodic moving average (MA) parameters. Such a model is Univariate Seasonal periodic autoregressive moving average (PARMA) model and is expressed as Univariate Seasonal PARMA(p,q) model. The stochastic models are generally simple to use. When the errors, however, happen in model identification and parameter estimation, the generated data using the stochastic models cannot reconstruct the statistical properties of the observed data exactly. Furthermore, the high-order PARMA(p,q) models have generally many parameters, and the calculation process is much complex (Salas et al., 1980). In this study, the author determined in advance 4 kinds of Univariate Seasonal PARMA(p,q) models including PARMA(1,1), PARMA(1,2), PARMA (2,1), and PARMA(2,2), which are the low-order models and contain the seasonal properties. In general, the low-order Univariate Seasonal PARMA(p,q) models are useful for the periodic hydrologic time series modeling (Salas et al., 1982). Furthermore, the author generated 100 years data in advance using each Univariate Seasonal PARMA(p,q) model for the climatic variables of the neural networks models, respectively. As a result, the author selected Univariate Seasonal PARMA(1,1) model, which shows the best statistical properties and is simple in parameter estimation. Univariate Seasonal PARMA(1,1) model has been applied to monthly streamflow time series from the previous studies (Tao and Delleur, 1976; Hirsch, 1979), and is shown as the following equation (2).

$$y_{v,\tau} = \mu_{\tau} + \phi_{1,\tau}(y_{v,\tau-1} - \mu_{\tau-1}) + \varepsilon_{v,\tau} - \theta_{1,\tau}\varepsilon_{v,\tau-1} \quad (2)$$

where  $y_{v,\tau} / y_{v,\tau-1}$  = the monthly PE and FAO-56 PM  $ET_o$  for year= v and month=  $\tau / \tau - 1$  ;  $\mu_{\tau} / \mu_{\tau-1}$  = the means for month=  $\tau / \tau - 1$  ;  $\phi_{1,\tau}$  = the seasonal autoregressive parameter for month=  $\tau$  ;  $\theta_{1,\tau}$  = the seasonal moving average parameter for month=  $\tau$  ;  $\varepsilon_{v,\tau} / \varepsilon_{v,\tau-1}$  = uncorrelated noise terms; v = year;  $\tau$  = month (1,2,...,  $\omega$ ); and  $\omega = 12$ . Furthermore, Univariate Seasonal PARMA(2,1), PARMA(2,2) models, and more complex multiplicative PARMA(p,q) models may be needed for hydrologic modeling and simulation when the preservation of both the seasonal and the annual statistics is desired (Salas and Abdelmohsen, 1993).

#### 3.2 Construction of Univariate Seasonal PARMA(p,q) model

The author used Univariate Seasonal PARMA(1,1) model to generate the sufficient training dataset, and obtained two generated samples. They included the input nodes/variables including mean temperature ( $T_{mean}$ ), maximum temperature ( $T_{max}$ ), minimum temperature ( $T_{min}$ ), mean dew point temperature ( $DP_{mean}$ ), minimum relative humidity ( $RH_{min}$ ), mean relative humidity ( $RH_{mean}$ ), mean wind speed ( $WS_{mean}$ ), maximum wind speed ( $WS_{max}$ ), and sunshine duration (SD) in mean values and the output nodes/variables including PE and

FAO-56 PM  $ET_0$  in total values, respectively. Furthermore, they were generated for 100 years (Short-term), 500 years (Mid-term), and 1000 years (Long-term), respectively. The author selected the second generated sample, and the first 50 years of the 100, 500, and 1000 years was abandoned to eliminate the biases, respectively. The parameters of Univariate Seasonal PARMA(1,1) model were determined using the method of approximate least square, respectively.

#### 4. Support Vector Machine Neural Networks Model (SVM-NNM)

SVM-NNM has found wide application in several areas including pattern recognition, regression, multimedia, bio-informatics and artificial intelligence. Very recently, SVM-NNM is gaining recognition in hydrology (Dibike et al., 2001; Khadam & Kaluarachchi, 2004). SVM-NNM implements the structural risk minimization principle which attempts to minimize an upper bound on the generalization error by striking a right balance between the training performance error and the capacity of machine. The solution of traditional neural networks models such as MLP-NNM may tend to fall into a local optimal solution, whereas global optimum solution is guaranteed for SVM-NNM (Haykin, 2009). SVM-NNM is a new kind of classifier that is motivated by two concepts. First, transforming data into a high-dimensional space can transform complex problems into simpler problems that can use linear discriminant functions. Second, SVM-NNM is motivated by the concept of training and using only those inputs that are near the decision surface since they provide the most information about the classification. The first step in SVM-NNM is transforming the data into a high-dimensional space. This is done using radial basis function (RBF) that places a Gaussian at each sample data. Thus, the feature space becomes as large as the number of sample data. RBF uses backpropagation to train a linear combination of the gaussians to produce the final result. SVM-NNM, however, uses the idea of large margin classifiers for the training performance. This decouples the capacity of the classifier from the input space and at the same time provides good generalization. This is an ideal combination for classification (Vapnik, 1992, 2000; Principe et al., 2000; Tripathi et al., 2006).

In this study, the basic ideas of SVM-NNM are reviewed. Consider the finite training pattern  $(x_i, y_i)$ . where  $x_i \in \mathcal{R}^n$  = a sample value of the input vector  $x$  considering of  $N$  training patterns; and  $y_i \in \mathcal{R}^n$  = the corresponding value of the desired model output. A nonlinear transformation function  $\phi(\cdot)$  is defined to map the input space to a higher dimension feature space,  $\mathcal{R}^{n_h}$ . According to Cover's theorem (Cover, 1965), a linear function,  $f(\cdot)$ , could be formulated in the high dimensional feature space to look for a nonlinear relationship between inputs and outputs in the original input space. It can be written as the following equation (3).

$$\bar{y} = f(x) = w^T \phi(x) + b \quad (3)$$

where  $\bar{y}$  = the actual model output. The coefficient  $w$  and  $b$  are adjustable model parameters. In SVM-NNM, we aim at minimizing the empirical risk. It can be written as the following equation (4).

$$R_{\text{emp}} = \frac{1}{N} \sum_{i=1}^N |y_i - \bar{y}_i|_{\varepsilon} \quad (4)$$

where  $R_{\text{emp}}$  = the empirical risk; and  $|y_i - \bar{y}_i|_\epsilon$  = the Vapnik's  $\epsilon$ -insensitive loss function. Following regularization theory (Haykin, 2009), the parameters  $w$  and  $b$  are calculated by minimizing the cost function. It can be written as the following equation (5).

$$\psi_\epsilon(w, \xi, \xi^*) = \frac{1}{2} w^T w + C \sum_{i=1}^N (\xi_i + \xi_i^*) \quad (5)$$

subject to the constraints: 1)  $y_i - \bar{y}_i \leq \epsilon + \xi_i$   $i = 1, 2, \dots, N$ , 2)  $-y_i + \bar{y}_i \leq \epsilon + \xi_i^*$   $i = 1, 2, \dots, N$ , and 3)  $\xi_i, \xi_i^* \geq 0$   $i = 1, 2, \dots, N$ . where  $\psi_\epsilon(w, \xi, \xi^*)$  = the cost function;  $\xi_i, \xi_i^*$  = positive slack variables; and  $C$  = the cost constant. The first term of the cost function, which represents weight decay, is used to regularize weight sizes and to penalize large weights. This helps in improving generalization performance (Hush and Horne, 1993). The second term of the cost function, which represents penalty function, penalizes deviations of  $\bar{y}$  from  $y$  larger than  $\pm\epsilon$  using Vapnik's  $\epsilon$ -insensitive loss function. The cost constant  $C$  determines the amount up to which deviations from  $\epsilon$  are tolerated. Deviations above  $\epsilon$  are denoted by  $\xi_i$ , whereas deviations below  $-\epsilon$  are denoted by  $\xi_i^*$ . The constrained quadratic optimization problem can be solved using the method of Lagrangian multipliers (Haykin, 2009). From this solution, the coefficient  $w$  can be written as the following equation (6).

$$w = \sum_{i=1}^N (\alpha_i - \alpha_i^*) \phi(x_i) \quad (6)$$

where  $\alpha_i, \alpha_i^*$  = the Lagrange multipliers, which are positive real constants. The data points corresponding to non-zero values for  $(\alpha_i - \alpha_i^*)$  are called support vectors. In SVM-NNM to calculate PE and FAO-56 PM  $ET_o$ , there are several possibilities for the choice of kernel function, including linear, polynomial, sigmoid, splines and RBF. In this study, RBF is used to map the input data into higher dimensional feature space. RBF can be written as the following equation (7).

$$k(x, x_j) = \Phi_1 = \exp(-B_1 R_j^2) = \exp\left(-\frac{\|x_i - x_j\|^2}{2\sigma^2}\right) \quad (7)$$

where  $i, j$  = the input layer and the hidden layer;  $K(x, x_j) = \Phi_1$  = the inner product kernel function;  $B_1 = \frac{1}{2\sigma^2}$ , and has a constant value; and  $\sigma$  = the width/spread of RBF, which can be adjusted to control the expressivity of RBF. The function for the single node of the output layer which receives the calculated results of RBF can be written as the following equation (8).

$$G_k = \left[ \sum_{j=1}^N (\alpha_j - \alpha_j^*) \cdot K(x, x_j) \right] + B \quad (8)$$

where  $k$  = the output layer;  $G_k$  = the calculated value of the single output node; and  $B$  = the bias in the output layer. Equation (8), finally, takes the form of equation (9) and (10), which represents SVM-NNM for the modeling of PE and FAO-56 PM  $ET_o$ .

$$PE = W_1 \cdot \Phi_2(G_k) = W_1 \cdot \Phi_2\left[\left[\sum_{j=1}^N (\alpha_j - \alpha_j^*) \cdot K(x, x_j)\right] + B\right] \quad (9)$$

$$FAO-56 \text{ PM } ET_o = W_2 \cdot \Phi_2(G_k) = W_2 \cdot \Phi_2\left[\left[\sum_{j=1}^N (\alpha_j - \alpha_j^*) \cdot K(x, x_j)\right] + B\right] \quad (10)$$

where  $\Phi_2(\cdot)$  = the linear sigmoid transfer function;  $W_1$  = the specific weights connected to the output variable of PE; and  $W_2$  = the specific weights connected to the output variable of FAO-56 PM  $ET_o$ . A number of SVM-NNM computer programs are now available for the modeling of PE and FAO-56 PM  $ET_o$ . NeuroSolutions 5.0 computer program was used to develop SVM-NNM structure. Fig. 2 shows the developed structure of SVM-NNM. From the Fig. 2, the input nodes/variables of climatic data are mean temperature ( $T_{mean}$ ), maximum temperature ( $T_{max}$ ), minimum temperature ( $T_{min}$ ), mean dew point temperature ( $DP_{mean}$ ), minimum relative humidity ( $RH_{min}$ ), mean relative humidity ( $RH_{mean}$ ), mean wind speed ( $WS_{mean}$ ), maximum wind speed ( $WS_{max}$ ), and sunshine duration (SD) in mean values (01/1985-12/1990). The output nodes/variables of climatic data are PE and FAO-56 PM  $ET_o$  in total values (01/1985-12/1990).

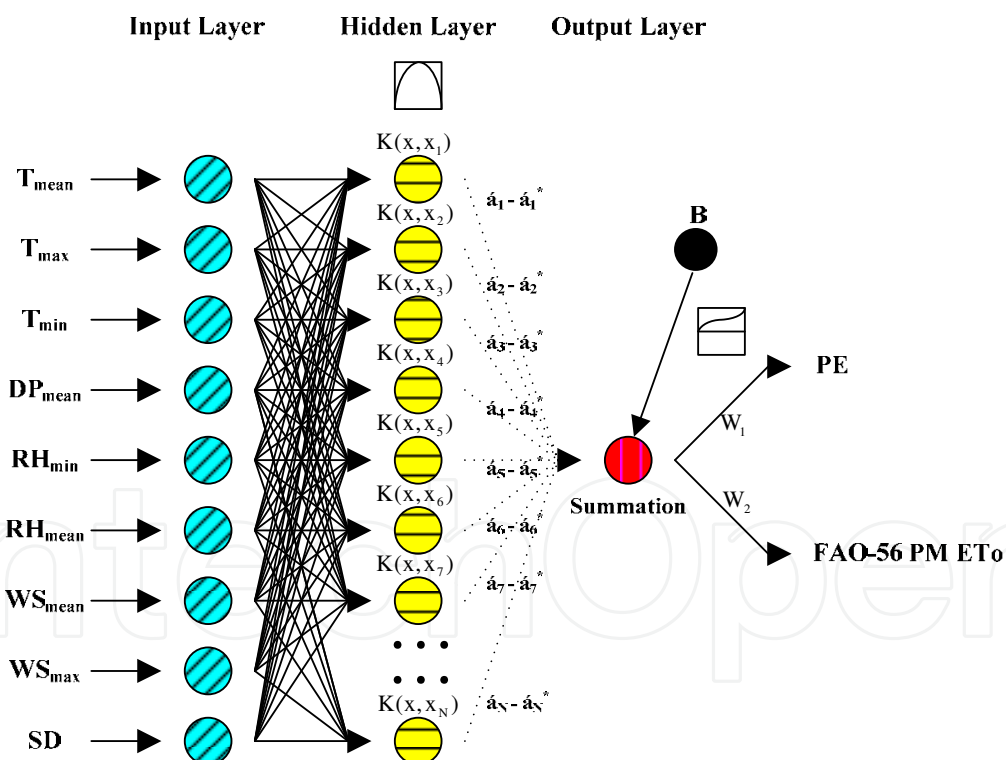

Fig. 2. The developed structure of SVM-NNM

## 5. Study scope and data

In this study, Gwangju and Haenam stations from the Yeongsan River catchment are selected among the 71 weather stations including Jeju-do under the control of the Korea meteorological administration (KMA). They have possessed long-term climatic data dating



back over at least 30 years. The Yeongsan River catchment covers an area of 3455 km<sup>2</sup>, and lies between latitudes 34.4°N and 35.2°N, and between longitudes 126.2°E and 127.0°E. Fig. 3 shows the Yeongsan River catchment including Gwangju and Haenam stations. The climatic data, which was necessary for the modeling of PE and FAO-56 PM ET<sub>o</sub>, were collected from the Internet homepage of water management information system ([www.wamis.go.kr](http://www.wamis.go.kr)) and the Korea meteorological administration ([www.kma.go.kr](http://www.kma.go.kr)).



Fig. 3. The Yeongsan River Catchment including Gwangju and Haenam stations

## 6. SVM-NNM performance

### 6.1 Performance statistics

The performance of SVM-NNM to account for calculating the monthly PE and FAO-56 PM ET<sub>o</sub> was evaluated using a wide variety of standard statistics index. A total of 3 different standard statistics indexes were employed; the coefficient of correlation (CC), root mean square error (RMSE), and Nash-Sutcliffe coefficient (R<sup>2</sup>) (Nash & Sutcliffe, 1970; ASCE, 1993). Table 1 shows summary of the statistics index in this study. where  $\bar{y}_i(x)$  = the calculated PE and FAO-56 PM ET<sub>o</sub> (mm/month);  $y_i(x)$  = the observed PE and FAO-56 PM ET<sub>o</sub> (mm/month);  $\bar{u}_y$  = mean of the calculated PE and FAO-56 PM ET<sub>o</sub> (mm/month);  $u_y$  = mean of the observed PE and FAO-56 PM ET<sub>o</sub> (mm/month); and  $n$  = total number of the monthly PE and FAO-56 PM ET<sub>o</sub> considered. A model which is effective in the modeling of PE and FAO-56 PM ET<sub>o</sub> accurately, and efficient in capturing the complex relationship among the various inputs and output variables involved in a particular problem, is considered the best. CC, RMSE, and R<sup>2</sup> statistics quantify the efficiency of SVM-NNM in capturing the extremely complex, dynamic, and nonlinear relationships (Kim, 2011).

Statistics Indexes	Equation
CC	$\frac{\frac{1}{n} \sum_{i=1}^n [y_i(x) - u_y][\bar{y}_i(x) - \bar{u}_y]}{\sqrt{\frac{1}{n} \sum_{i=1}^n [y_i(x) - u_y]^2} \sqrt{\frac{1}{n} \sum_{i=1}^n [\bar{y}_i(x) - \bar{u}_y]^2}}$
RMSE	$\sqrt{\frac{1}{n} \sum_{i=1}^n [\bar{y}_i(x) - y_i(x)]^2}$
R <sup>2</sup>	$1 - \frac{\sum_{i=1}^n [y_i(x) - \bar{y}_i(x)]^2}{\sum_{i=1}^n [y_i(x) - u_y]^2}$

Table 1. Summary of statistics indexes

### 6.2 Data normalization

The climatic data used in this study including mean temperature ( $T_{\text{mean}}$ ), maximum temperature ( $T_{\text{max}}$ ), minimum temperature ( $T_{\text{min}}$ ), mean dew point temperature ( $DP_{\text{mean}}$ ), minimum relative humidity ( $RH_{\text{min}}$ ), mean relative humidity ( $RH_{\text{mean}}$ ), mean wind speed ( $WS_{\text{mean}}$ ), maximum wind speed ( $WS_{\text{max}}$ ), and sunshine duration (SD) were normalized for preventing and overcoming problem associated with the extreme values. An important reason for the normalization of input nodes is that each of input nodes represents an observed value in a different unit. Such input nodes are normalized, and the input nodes in dimensionless unit are relocated. The similarity effect of input nodes is thus eliminated (Kim et al., 2009). According to Zanetti et al. (2007), by grouping the daily values into averages,  $ET_0$  may be calculated due to their highest stabilization. For data normalization, the data of input and output nodes were scaled in the range of [0 1] using the following equation (11).

$$Y_{\text{norm}} = \frac{Y_i - Y_{\text{min}}}{Y_{\text{max}} - Y_{\text{min}}} \quad (11)$$

where  $Y_{\text{norm}}$  = the normalized dimensionless data of the specific input node/variable;  $Y_i$  = the observed data of the specific input node/variable;  $Y_{\text{min}}$  = the minimum data of the specific input node/variable; and  $Y_{\text{max}}$  = the maximum data of the specific input node/variable.

### 6.3 Training performance

The method for calculating parameters is generally called the training performance in the neural networks model category. The training performance of neural networks model is iterated until the training error is reached to the training tolerance. Iteration means one completely pass through a set of inputs and target patterns or data. In general, it is assumed

that the neural networks model does not have any prior knowledge about the example problem before it is trained (Kim, 2004). A difficult task with the neural networks model is to choose the number of hidden nodes. The network geometry is problem dependent. This study adopted one hidden layer for the construction of SVM-NNM since it is well known that one hidden layer is enough to represent PE and FAO-56 PM  $ET_o$  nonlinear complex relationship (Kumar et al., 2002; Zanetti et al., 2007). The testing performance in the modeling of PE and FAO-56 PM  $ET_o$ , therefore, is carried out using the optimal parameters, which are calculated during the training performance.

The hybrid method, which was developed in this study, consisted of the following training patterns. First, the stochastic model was selected. As explained previously, Univariate Seasonal PARMA(1,1) model, which consisted of 1 pattern only, was used to generate the training dataset. Second, the data, which were generated by Univariate Seasonal PARMA(1,1) model, consisted of 3 patterns including 100 years (Short-term), 500 years (Mid-term), and 1000 years (Long-term), respectively. Finally, the neural networks model, which consisted of 1 pattern only including SVM-NNM, was used for the training and testing performances, respectively. Therefore, the hybrid method consisted of 3 training patterns including 100/PARMA(1,1)/SVM-NNM, 500/PARMA(1,1)/SVM-NNM, and 1000/PARMA(1,1)/SVM-NNM, respectively. For Gwangju and Haenam stations, the training dataset including the climatic, PE, and FAO-56 PM  $ET_o$  data were generated by Univariate Seasonal PARMA(1,1) model using observed data (01/1985-12/1990) for 100 years (Short-term), 500 years (Mid-term), and 1000 years (Long-term), respectively. After the first 50 years of the generated data for 100, 500, and 1000 years was abandoned to eliminate the biases, the training performance should be carried out using SVM-NNM. Therefore, the total amount of data used for the training performance consisted of 600, 5400, and 11400, respectively. For the training performance of SVM-NNM, NeuroSolutions 5.0 computer program was used to carry out the training performance. Fig. 4(a)-(b) show SVM-NNM training performance using NeuroSolutions 5.0 computer program.

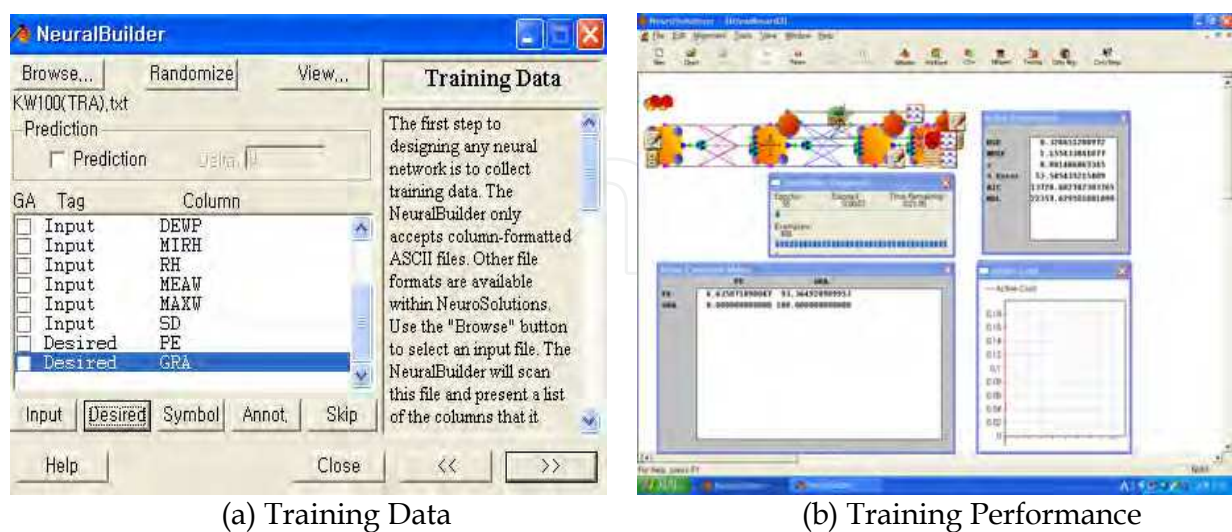

Fig. 4. SVM-NNM training performance using NeuroSolution 5.0 Computer Program

Table 2 shows the statistics results of the training performances for 3 training patterns of PE modeling. In PE of Gwangju station, from the Table 2, 100/PARMA(1,1)/SVM-NNM

training pattern produced the statistics results with CC value of 0.929, RMSE value of 16.360 mm and  $R^2$  value of 0.858. 500/PARMA(1,1)/SVM-NNM training pattern produced the statistics results with CC value of 0.919, RMSE value of 17.942 mm and  $R^2$  value of 0.833. 1000/PARMA(1,1)/SVM-NNM training pattern produced the statistics results with CC value of 0.905, RMSE value of 20.489 mm and  $R^2$  value of 0.781, respectively. In PE of Haenam station, from the Table 2, 100/PARMA(1,1)/SVM-NNM training pattern produced the statistics results with CC value of 0.965, RMSE value of 9.643 mm and  $R^2$  value of 0.930. 500/PARMA(1,1)/SVM-NNM training pattern produced the statistics results with CC value of 0.958, RMSE value of 10.673 mm and  $R^2$  value of 0.914. 1000/PARMA(1,1)/SVM-NNM training pattern produced the statistics results with CC value of 0.962, RMSE value of 10.105 mm and  $R^2$  value of 0.922, respectively. From the above results, the statistics results of the training performance for 100/PARMA(1,1)/SVM-NNM training pattern were better than those of the training performances for 500/PARMA(1,1)/SVM-NNM and 1000/PARMA(1,1)/SVM-NNM training patterns for PE of Gwangju and Haenam stations, respectively.

Station	Statistics Indexes	100/PARMA(1,1)/SVM-NNM	500/PARMA(1,1)/SVM-NNM	1000/PARMA(1,1)/SVM-NNM
Gwangju	CC	0.929	0.919	0.905
	RMSE (mm)	16.360	17.942	20.489
	$R^2$	0.858	0.833	0.781
Haenam	CC	0.965	0.958	0.962
	RMSE (mm)	9.643	10.673	10.105
	$R^2$	0.930	0.914	0.922

Table 2. Statistics results of the training performances (PE)

Table 3 shows the statistics results of the training performances for 3 training patterns of FAO-56 PM  $ET_o$  modeling. In FAO-56 PM  $ET_o$  of Gwangju station, from the Table 3, 100/PARMA(1,1)/SVM-NNM training pattern produced the statistics results with CC value of 0.975, RMSE value of 8.517 mm and  $R^2$  value of 0.948. 500/PARMA(1,1)/SVM-NNM training pattern produced the statistics results with CC value of 0.966, RMSE value of 10.237 mm and  $R^2$  value of 0.924. 1000/PARMA(1,1)/SVM-NNM training pattern produced the statistics results with CC value of 0.963, RMSE value of 11.061 mm and  $R^2$  value of 0.911, respectively. In FAO-56 PM  $ET_o$  of Haenam station, from the Table 3, 100/PARMA(1,1)/SVM-NNM training pattern produced the statistics results with CC value of 0.965, RMSE value of 9.935 mm and  $R^2$  value of 0.926. 500/PARMA(1,1)/SVM-NNM training pattern produced the statistics results with CC value of 0.956, RMSE value of 10.822 mm and  $R^2$  value of 0.912. 1000/PARMA(1,1)/SVM-NNM training pattern produced the statistics results with CC value of 0.962, RMSE value of 10.014 mm and  $R^2$  value of 0.925, respectively. From the above results, the statistics results of the training performance for 100/PARMA(1,1)/SVM-NNM training pattern were better than those of the training performances for 500/PARMA(1,1)/SVM-NNM and 1000/PARMA(1,1)/SVM-NNM training patterns for FAO-56 PM  $ET_o$  of Gwangju and Haenam stations, respectively. Therefore, the data length has less effect on the training performance of PE and FAO-56 PM  $ET_o$  in this study. Tokar and Johnson (1999) suggested that the data length has less effect on

the neural networks model performance than the data quality. Sivakumar et al. (2002) suggested that it is imperative to select a good training dataset from the available data series. They indicated that the best way to achieve a good training performance seems to be to include most of the extreme events such as very high and very low values in the training dataset. Furthermore, Kim (2011) did not carry out the statistics analysis of the training performance since the training dataset of 6 training patterns consisted of the generated (not observed) data only.

Station	Statistics Indexes	100/PARMA(1,1)/SVM-NNM	500/PARMA(1,1)/SVM-NNM	1000/PARMA(1,1)/SVM-NNM
Gwangju	CC	0.975	0.966	0.963
	RMSE (mm)	8.517	10.237	11.061
	R <sup>2</sup>	0.948	0.924	0.911
Haenam	CC	0.965	0.956	0.962
	RMSE (mm)	9.935	10.822	10.014
	R <sup>2</sup>	0.926	0.912	0.925

Table 3. Statistics results of the training performances (FAO-56 PM ET<sub>o</sub>)

#### 6.4 Testing performance

The neural networks model is tested by determining whether the model meets the objectives of modeling within some preestablished criteria or not. Of course, the optimal parameters, which are calculated during the training performance, are applied for the testing performance of the neural networks model (Kim, 2004). For the testing performance, the monthly climatic data (01/1985-12/1990) in Gwangju and Haenam stations were used. The total amount of data used for the testing performance consisted of 72 data for the monthly time series. The testing performance applied the cross-validation method in order to overcome the over-fitting problem of SVM-NNM. The cross-validation method is not to train all the training data until SVM-NNM reaches the minimum RMSE, but is to cross-validate with the testing data at the end of each training performance. If the over-fitting problem occurs, the convergence process over the mean square error of the testing data will not decrease but will increase as the training data are still trained (Bishop, 1994; Haykin, 2009).

Table 4 shows the statistics results of the testing performances for 3 training patterns of PE modeling. In PE of Gwangju station, from the Table 4, 100/PARMA(1,1)/SVM-NNM training pattern produced the statistics results with CC value of 0.955, RMSE value of 12.239 mm and R<sup>2</sup> value of 0.908. 500/PARMA(1,1)/SVM-NNM training pattern produced the statistics results with CC value of 0.956, RMSE value of 13.501 mm and R<sup>2</sup> value of 0.888. 1000/PARMA(1,1)/SVM-NNM training pattern produced the statistics results with CC value of 0.953, RMSE value of 15.103 mm and R<sup>2</sup> value of 0.860, respectively. In PE of Haenam station, from the Table 4, 100/PARMA(1,1)/SVM-NNM training pattern produced the statistics results with CC value of 0.966, RMSE value of 9.581 mm and R<sup>2</sup> value of 0.932. 500/PARMA(1,1)/SVM-NNM training pattern produced the statistics results with CC value of 0.968, RMSE value of 9.370 mm and R<sup>2</sup> value of 0.935. 1000/PARMA(1,1)/SVM-NNM training pattern produced the statistics results with CC value of 0.953, RMSE value of 11.313 mm and R<sup>2</sup> value of 0.905, respectively. From the above results, the statistics results of the

testing performance for 100/PARMA(1,1)/SVM-NNM training pattern were better than those of the testing performances for 500/PARMA(1,1)/SVM-NNM and 1000/PARMA(1,1)/SVM-NNM training patterns for PE of Gwangju station. And, the statistics results of the testing performance for 500/PARMA(1,1)/SVM-NNM training pattern were better than those of the testing performances for 100/PARMA(1,1)/SVM-NNM and 1000/PARMA(1,1)/SVM-NNM training patterns for PE of Haenam station, respectively.

Station	Statistics Indexes	100/PARMA(1,1)/SVM-NNM	500/PARMA(1,1)/SVM-NNM	1000/PARMA(1,1)/SVM-NNM
Gwangju	CC	0.955	0.956	0.953
	RMSE (mm)	12.239	13.501	15.103
	R <sup>2</sup>	0.908	0.888	0.860
Haenam	CC	0.966	0.968	0.953
	RMSE (mm)	9.581	9.370	11.313
	R <sup>2</sup>	0.932	0.935	0.905

Table 4. Statistics results of the testing performances (PE)

Table 5 shows the statistics results of the testing performances for 3 training patterns of FAO-56 PM ET<sub>o</sub> modeling. In FAO-56 PM ET<sub>o</sub> of Gwangju station, from the Table 5, 100/PARMA(1,1)/SVM-NNM training pattern produced the statistics results with CC value of 0.981, RMSE value of 7.300 mm and R<sup>2</sup> value of 0.962. 500/PARMA(1,1)/SVM-NNM training pattern produced the statistics results with CC value of 0.974, RMSE value of 8.803 mm and R<sup>2</sup> value of 0.944. 1000/PARMA(1,1)/SVM-NNM training pattern produced the statistics results with CC value of 0.976, RMSE value of 9.448 mm and R<sup>2</sup> value of 0.936, respectively. In FAO-56 PM ET<sub>o</sub> of Haenam station, from the Table 5, 100/PARMA(1,1)/SVM-NNM training pattern produced the statistics results with CC value of 0.971, RMSE value of 9.007 mm and R<sup>2</sup> value of 0.939. 500/PARMA(1,1)/SVM-NNM training pattern produced the statistics results with CC value of 0.970, RMSE value of 8.882 mm and R<sup>2</sup> value of 0.941. 1000/PARMA(1,1)/SVM-NNM training pattern produced the statistics results with CC value of 0.972, RMSE value of 8.581 mm and R<sup>2</sup> value of 0.945, respectively. From the above results, the statistics results of the testing performance for 100/PARMA(1,1)/SVM-NNM training pattern were better than those of the testing performances for 500/PARMA(1,1)/SVM-NNM and 1000/PARMA(1,1)/SVM-NNM training patterns for FAO-56 PM ET<sub>o</sub> of Gwangju station. And, the statistics results of the testing performance for 1000/PARMA(1,1)/SVM-NNM training pattern were better than those of the testing performances for 100/PARMA(1,1)/SVM-NNM and 500/PARMA(1,1)/SVM-NNM training patterns for FAO-56 PM ET<sub>o</sub> of Haenam station, respectively. Kim (2011) suggested, however, that the statistics results of testing performance for 1000/PARMA(1,1)/GRNNM-GA training pattern were better than those of testing performances for 100/PARMA(1,1)/GRNNM-GA and 500/PARMA(1,1)/GRNNM-GA training patterns for the modeling of PE and ET<sub>r</sub>, South Korea. The continuous research will be needed to establish the neural networks models available for the optimal training patterns and modeling of PE and FAO-56 PM ET<sub>o</sub>.

From the statistics results of the testing performances for PE and FAO-56 PM ET<sub>o</sub>, the statistics results of FAO-56 PM ET<sub>o</sub> were better than those of PE. PE is the observed data as a

reason and represents the natural phenomenon including strong nonlinear patterns and various uncertainties, whereas  $ET_o$  is calculated by FAO-56 PM equation with the constant operation processes. In FAO-56 PM  $ET_o$ , furthermore, the strong nonlinear patterns of the natural phenomena are transformed into linear patterns including the constant uncertainty. The author can consider that the modeling of FAO-56 PM  $ET_o$  has significantly less uncertainty compared to that of PE. Kim (2011) suggested the similar results for the modeling of PE and  $ET_r$  using the neural networks models. He suggested that the statistics results of  $ET_r$  were better than those of PE for the modeling of PE and  $ET_r$  using GRNNM-BP and GRNNM-GA, South Korea. Fig. 5(a)-(f) show comparison plots of observed and calculated PE/FAO-56 PM  $ET_o$  for the testing performances of 3 training patterns for Gwangju station, respectively. Fig. 6(a)-(f) show comparison plots of observed and calculated PE/FAO-56 PM  $ET_o$  for the testing performances of 3 training patterns for Haenam station, respectively.

Station	Statistics Indexes	100/PARMA(1,1)/SVM-NNM	500/PARMA(1,1)/SVM-NNM	1000/PARMA(1,1)/SVM-NNM
Gwangju	CC	0.981	0.974	0.976
	RMSE (mm)	7.300	8.803	9.448
	R <sup>2</sup>	0.962	0.944	0.936
Haenam	CC	0.971	0.970	0.972
	RMSE (mm)	9.007	8.882	8.581
	R <sup>2</sup>	0.939	0.941	0.945

Table 5. Statistics results of the testing performances (FAO-56 PM  $ET_o$ )

## 6.5 Homogeneity evaluation

FAO-56 PM  $ET_o$  equation, which has been unanimously accepted by the FAO consultation members for  $ET_o$  calculation (Allen et al., 1998), was used to calculate  $ET_o$  since there are no observed data for  $ET_o$  using a lysimeter, South Korea. Even if FAO-56 PM  $ET_o$  is not observed data, the reliability for the calculated FAO-56 PM  $ET_o$  is adequate and proper. Homogeneity evaluation was performed to compare the observed PE/FAO-56 PM  $ET_o$  with the calculated PE/FAO-56 PM  $ET_o$  for the results of the test performances, respectively. In this study, homogeneity evaluation consisted of the One-way ANOVA and the Mann-Whitney  $U$  test, respectively.

### 6.5.1 The One-way ANOVA

The One-way ANOVA is a class of statistical analysis that is widely used because it encourages systematic decision making for the underlying problems that involve considerable uncertainty. It enables inferences to be made in such a way that sample data can be combined with statistical theory. It supposedly removes the effects of the biases of the individual, which leads to more rational and accurate decision making. The One-way ANOVA is the formal procedure for using statistical concepts and measures in performing decision making. The following six steps can be used to make statistical analysis of the One-way ANOVA on the means and variances: 1) Formulation of hypotheses 2) Define the test statistic and its distribution 3) Specify the level of significance 4) Collect data and compute

test statistic 5) Determine the critical value of the test statistic 6) Make a decision (McCuen, 1993; Salas et al., 2001; Ayyub and McCuen, 2003).

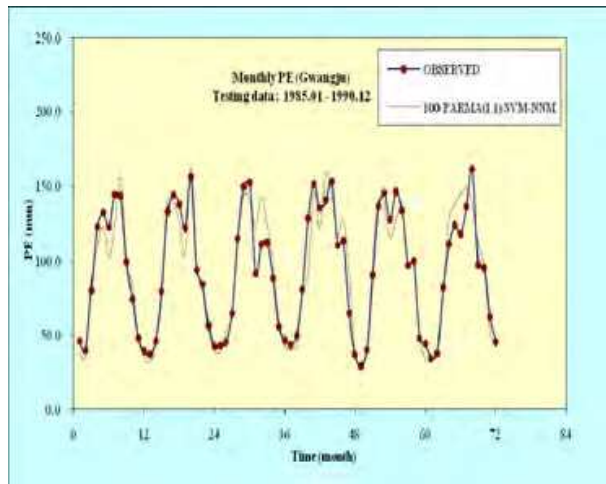

(a) PE (100 year)

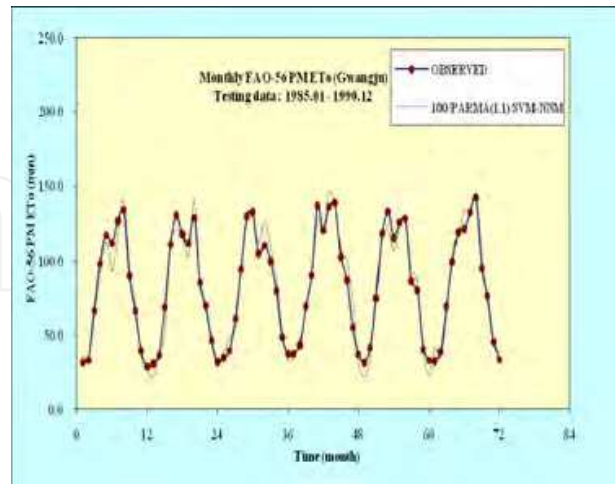

(b) FAO-56 PM ET<sub>o</sub> (100 year)

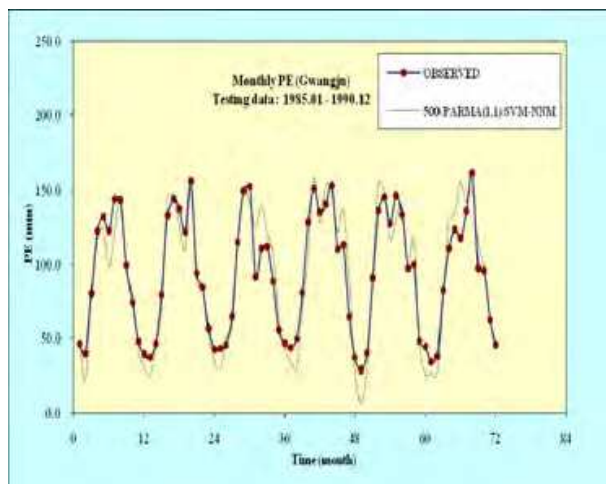

(c) PE (500 year)

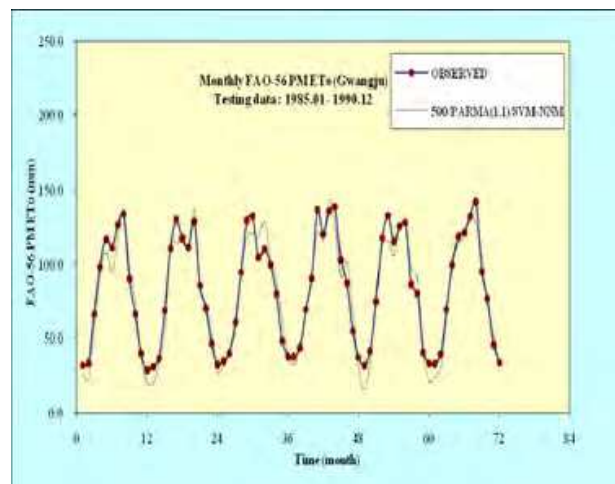

(d) FAO-56 PM ET<sub>o</sub> (500 year)

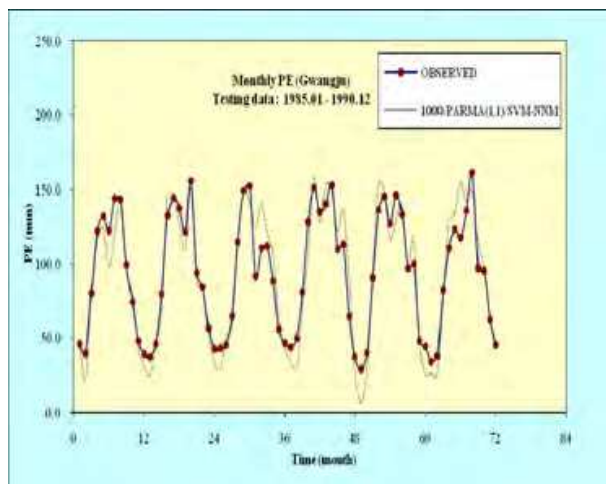

(e) PE (1000 year)

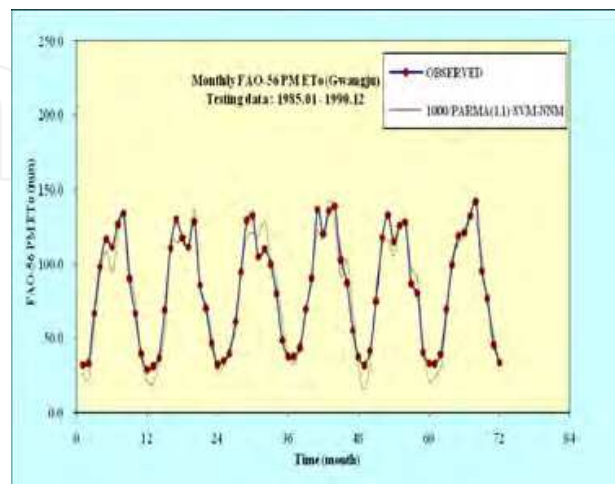

(f) FAO-56 PM ET<sub>o</sub> (1000 year)

Fig. 5. Comparison plots of observed and calculated PE and FAO-56 PM ET<sub>o</sub> (Gwangju)



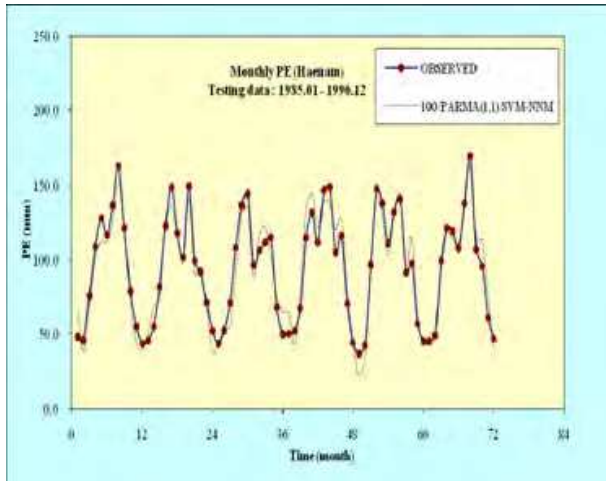

(a) PE (100 year)

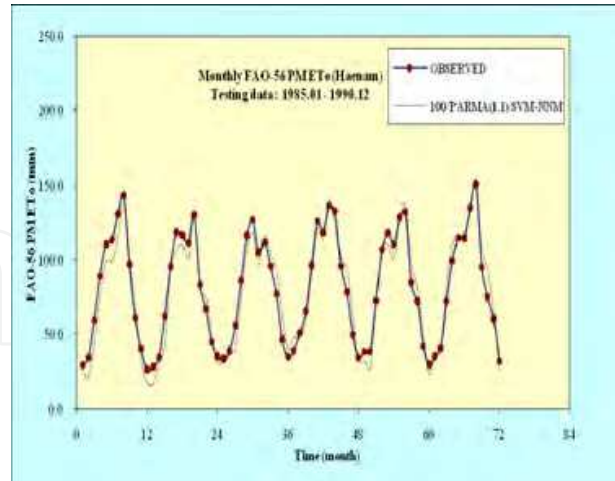

(b) FAO-56 PM  $ET_o$  (100 year)

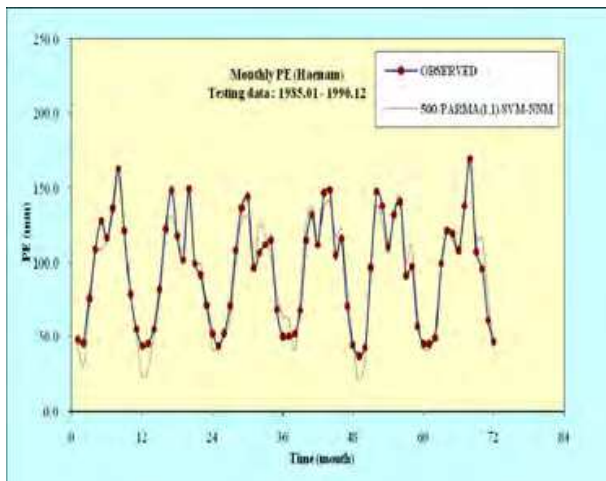

(c) PE (500 year)

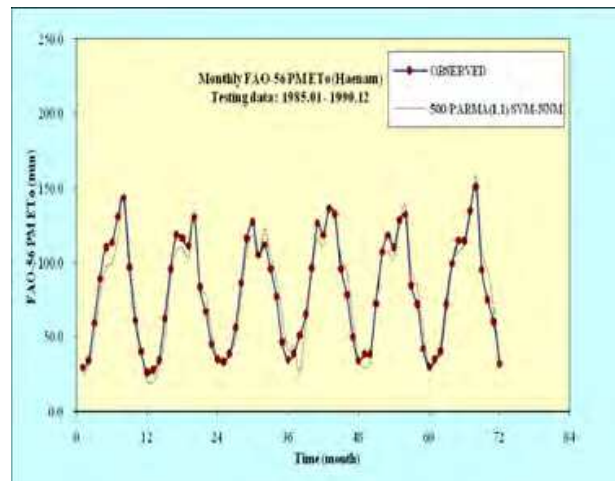

(d) FAO-56 PM  $ET_o$  (500 year)

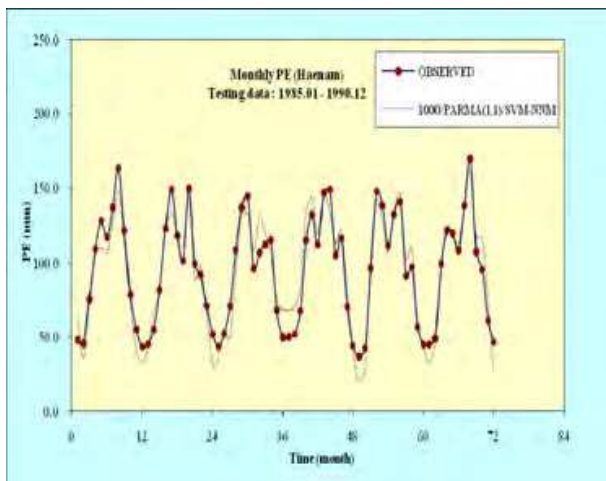

(e) PE (1000 year)

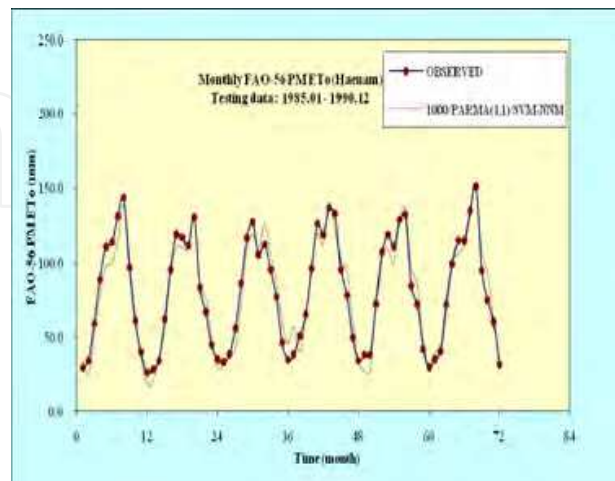

(f) FAO-56 PM  $ET_o$  (1000 year)

Fig. 6. Comparison plots of observed and calculated PE and FAO-56 PM  $ET_o$  (Haenam)

The One-way ANOVA on the means was performed and computed  $t$  statistic using two-sample  $t$  test between the observed PE/FAO-56 PM  $ET_o$  and the calculated PE/FAO-56 PM  $ET_o$ , respectively. The critical value of  $t$  statistic was computed for the level of significance 5 percent (5%) and 1 percent (1%). If the computed value of  $t$  statistic is greater than the critical value of  $t$  statistic, the null hypothesis, which is the means are equal, should be rejected and the alternative hypothesis should be accepted. The One-way ANOVA on the variances was performed and computed  $F$  statistic using two-sample  $F$  test between the observed PE/FAO-56 PM  $ET_o$  and the calculated PE/FAO-56 PM  $ET_o$ , respectively. The critical value of  $F$  statistic was computed for the level of significance 5 percent (5%) and 1 percent (1%). If the computed value of  $F$  statistic is greater than the critical value of  $F$  statistic, the null hypothesis, which is the population variances are equal, should be rejected and the alternative hypothesis should be accepted.

Table 6 shows the results of the One-way ANOVA on the means of PE. The critical value of  $t$  statistic was computed as  $t_{0.05} = 1.981$  and  $t_{0.01} = 2.620$  for the level of significance 5 percent (5%) and 1 percent (1%), respectively. The computed values of  $t$  statistic with 0.045 for 100/PARMA/SVM-NNM training pattern, 0.111 for 500/PARMA/SVM-NNM training pattern, 0.390 for 1000/PARMA/SVM-NNM training pattern were not significant for PE of Gwangju station. So, the null hypothesis, which is the means are equal, was accepted for PE of Gwangju station. Furthermore, the computed values of  $t$  statistic with 0.145 for 100/PARMA/SVM-NNM training pattern, 0.169 for 500/PARMA/SVM-NNM training pattern, 0.103 for 1000/PARMA/SVM-NNM training pattern were not significant for PE of Haenam station. So, the null hypothesis, which is the means are equal, was accepted for PE of Haenam station.

Station	Training Pattern	Level of Significance	Two-sample $t$ test		
			Critical $t$ Statistic	Computed $t$ Statistic	Null Hypothesis
Gwangju	100/PARMA(1,1)/SVM-NNM	0.05/0.01	1.981/2.620	0.045	Accept/Accept
	500/PARMA(1,1)/SVM-NNM	0.05/0.01	1.981/2.620	0.111	Accept/Accept
	1000/PARMA(1,1)/SVM-NNM	0.05/0.01	1.981/2.620	0.390	Accept/Accept
Haenam	100/PARMA(1,1)/SVM-NNM	0.05/0.01	1.981/2.620	0.145	Accept/Accept
	500/PARMA(1,1)/SVM-NNM	0.05/0.01	1.981/2.620	0.169	Accept/Accept
	1000/PARMA(1,1)/SVM-NNM	0.05/0.01	1.981/2.620	0.103	Accept/Accept

Table 6. Results of the One-way ANOVA on the means of PE

Table 7 shows the results of the One-way ANOVA on the means of FAO-56 PM  $ET_o$ . The critical value of  $t$  statistic was computed as  $t_{0.05} = 1.981$  and  $t_{0.01} = 2.620$  for the level of significance 5 percent (5%) and 1 percent (1%), respectively. The computed values of  $t$  statistic with 0.040 for 100/PARMA/SVM-NNM training pattern, 0.283 for 500/PARMA/SVM-NNM training pattern, 0.483 for 1000/PARMA/SVM-NNM training pattern were not significant for FAO-56 PM  $ET_o$  of Gwangju station. So, the null hypothesis, which is the means are equal, was accepted for FAO-56 PM  $ET_o$  of Gwangju station. Furthermore, the computed values of  $t$  statistic with 0.231 for 100/PARMA/SVM-NNM training pattern, 0.071 for 500/PARMA/SVM-NNM training pattern, 0.018 for 1000/PARMA/SVM-NNM training pattern were not significant for FAO-56 PM  $ET_o$  of Haenam station. So, the null hypothesis, which is the means are equal, was accepted for FAO-56 PM  $ET_o$  of Haenam station.

Station	Training Pattern	Level of Significance	Two-sample <i>t</i> test		
			Critical <i>t</i> Statistic	Computed <i>t</i> Statistic	Null Hypothesis
Gwangju	100/PARMA(1,1)/SVM-NNM	0.05/0.01	1.981/2.620	0.040	Accept/Accept
	500/PARMA(1,1)/SVM-NNM	0.05/0.01	1.981/2.620	0.283	Accept/Accept
	1000/PARMA(1,1)/SVM-NNM	0.05/0.01	1.981/2.620	0.483	Accept/Accept
Haenam	100/PARMA(1,1)/SVM-NNM	0.05/0.01	1.981/2.620	0.231	Accept/Accept
	500/PARMA(1,1)/SVM-NNM	0.05/0.01	1.981/2.620	0.071	Accept/Accept
	1000/PARMA(1,1)/SVM-NNM	0.05/0.01	1.981/2.620	0.018	Accept/Accept

Table 7. Results of the One-way ANOVA on the means of FAO-56 PM ET<sub>o</sub>.

Table 8 shows the results of the One-way ANOVA on the variances of PE. The critical value of *F* statistic was computed as  $F_{0.05} = 1.981$  and  $F_{0.01} = 2.620$  for the level of significance 5 percent (5%) and 1 percent (1%), respectively. The computed values of *F* statistic with 1.040 for 100/PARMA/SVM-NNM training pattern, 1.249 for 500/PARMA/SVM-NNM training pattern, 1.343 for 1000/PARMA/SVM-NNM training pattern were not significant for PE of Gwangju station. So, the null hypothesis, which is the variances are equal, was accepted for PE of Gwangju station. Furthermore, the computed values of *F* statistic with 1.033 for 100/PARMA/SVM-NNM training pattern, 1.030 for 500/PARMA/SVM-NNM training pattern, 1.036 for 1000/PARMA/SVM-NNM training pattern were not significant for PE of Haenam station. So, the null hypothesis, which is the variances are equal, was accepted for PE of Haenam station.

Station	Training Pattern	Level of Significance	Two-sample <i>F</i> test		
			Critical <i>F</i> Statistic	Computed <i>F</i> Statistic	Null Hypothesis
Gwangju	100/PARMA(1,1)/SVM-NNM	0.05/0.01	1.981/2.620	1.040	Accept/Accept
	500/PARMA(1,1)/SVM-NNM	0.05/0.01	1.981/2.620	1.249	Accept/Accept
	1000/PARMA(1,1)/SVM-NNM	0.05/0.01	1.981/2.620	1.343	Accept/Accept
Haenam	100/PARMA(1,1)/SVM-NNM	0.05/0.01	1.981/2.620	1.033	Accept/Accept
	500/PARMA(1,1)/SVM-NNM	0.05/0.01	1.981/2.620	1.030	Accept/Accept
	1000/PARMA(1,1)/SVM-NNM	0.05/0.01	1.981/2.620	1.036	Accept/Accept

Table 8. Results of the One-way ANOVA on the variances of PE

Table 9 shows the results of the One-way ANOVA on the variances of FAO-56 PM ET<sub>o</sub>. The critical value of *F* statistic was computed as  $F_{0.05} = 1.981$  and  $F_{0.01} = 2.620$  for the level of significance 5 percent (5%) and 1 percent (1%), respectively. The computed values of *F* statistic with 1.055 for 100/PARMA/SVM-NNM training pattern, 1.045 for 500/PARMA/SVM-NNM training pattern, 1.154 for 1000/PARMA/SVM-NNM training pattern were not significant for FAO-56 PM ET<sub>o</sub> of Gwangju station. So, the null hypothesis, which is the variances are equal, was accepted for FAO-56 PM ET<sub>o</sub> of Gwangju station. Furthermore, the computed values of *F* statistic with 1.033 for 100/PARMA/SVM-NNM training pattern, 1.021 for 500/PARMA/SVM-NNM training pattern, 1.031 for 1000/PARMA/SVM-NNM training pattern were not significant for FAO-56 PM ET<sub>o</sub> of Haenam station. So, the null hypothesis, which is the variances are equal, was accepted for FAO-56 PM ET<sub>o</sub> of Haenam station.

Station	Training Pattern	Level of Significance	Two-sample <i>F</i> test		
			Critical <i>F</i> Statistic	Computed <i>F</i> Statistic	Null Hypothesis
Gwangju	100/PARMA(1,1)/SVM-NNM	0.05/0.01	1.981/2.620	1.055	Accept/Accept
	500/PARMA(1,1)/SVM-NNM	0.05/0.01	1.981/2.620	1.045	Accept/Accept
	1000/PARMA(1,1)/SVM-NNM	0.05/0.01	1.981/2.620	1.154	Accept/Accept
Haenam	100/PARMA(1,1)/SVM-NNM	0.05/0.01	1.981/2.620	1.033	Accept/Accept
	500/PARMA(1,1)/SVM-NNM	0.05/0.01	1.981/2.620	1.021	Accept/Accept
	1000/PARMA(1,1)/SVM-NNM	0.05/0.01	1.981/2.620	1.031	Accept/Accept

Table 9. Results of the One-way ANOVA on the variances of FAO-56 PM ET<sub>o</sub>.

### 6.5.2 The Mann-Whitney *U* test

The Mann-Whitney *U* test is a nonparametric alternative to the two-sample *t* test for two independent samples and can be used to test whether two independent samples have been taken from the same population. It is the most powerful alternative to the two-sample *t* test. Therefore, when the assumptions of the two-sample *t* test are violated or are difficult to evaluate such as with small samples, the Mann-Whitney *U* test should be applied. The Mann-Whitney *U* test is to be used in the case of two independent samples, and the Kruskal-Wallis test is an extension of the Mann-Whitney *U* test for the case of more than two independent samples (McCuen, 1993; Salas et al., 2001; Ayyub and McCuen, 2003).

The Mann-Whitney *U* test was performed and computed *z* statistic between the observed PE/FAO-56 PM ET<sub>o</sub> and the calculated PE/FAO-56 PM ET<sub>o</sub>, respectively. The critical value of *z* statistic was computed for the level of significance 5 percent (5%) and 1 percent (1%). If the computed value of *z* statistic is greater than the critical value of *z* statistic, the null hypothesis, which is the two independent samples are from the same population, should be rejected and the alternative hypothesis should be accepted in this study.

Table 10 shows the results of the Mann-Whitney *U* test of PE. The critical value of *z* statistic was computed as  $z_{0.05} = 1.645$  and  $z_{0.01} = 2.327$  for the level of significance 5 percent (5%) and 1 percent (1%), respectively. The computed values of *z* statistic with -0.196 for 100/PARMA/SVM-NNM training pattern, -0.136 for 500/PARMA/SVM-NNM training pattern, -0.288 for 1000/PARMA/SVM-NNM training pattern were not significant for PE of Gwangju station. So, the null hypothesis, which is the two independent samples are from the same population, was accepted for PE of Gwangju station. Furthermore, the computed values of *z* statistic with -0.172 for 100/PARMA/SVM-NNM training pattern, -0.124 for 500/PARMA/SVM-NNM training pattern, -0.076 for 1000/PARMA/SVM-NNM training pattern were not significant for PE of Haenam station. So, the null hypothesis, which is the two independent samples are from the same population, was accepted for PE of Haenam station.

Table 11 shows the results of the Mann-Whitney *U* test of FAO-56 PM ET<sub>o</sub>. The critical value of *z* statistic was computed as  $z_{0.05} = 1.645$  and  $z_{0.01} = 2.327$  for the level of significance 5 percent (5%) and 1 percent (1%), respectively. The computed values of *z* statistic with -0.056 for 100/PARMA/SVM-NNM training pattern, -0.515 for 500/PARMA/SVM-NNM training pattern, -0.711 for 1000/PARMA/SVM-NNM training pattern were not significant for FAO-56 PM ET<sub>o</sub> of Gwangju station. So, the null hypothesis, which is the two independent samples are from the same population, was accepted for FAO-56 PM ET<sub>o</sub> of Gwangju

station. Furthermore, the computed values of  $z$  statistic with -0.380 for 100/PARMA/SVM-NNM training pattern, -0.212 for 500/PARMA/SVM-NNM training pattern, -0.176 for 1000/PARMA/SVM-NNM training pattern were not significant for FAO-56 PM  $ET_o$  of Haenam station. So, the null hypothesis, which is the two independent samples are from the same population, was accepted for FAO-56 PM  $ET_o$  of Haenam station.

Station	Training Pattern	Level of Significance	Mann-Whitney $U$ test		
			Critical $z$ Statistic	Computed $z$ Statistic	Null Hypothesis
Gwangju	100/PARMA(1,1)/SVM-NNM	0.05/0.01	1.645/2.327	-0.196	Accept/ Accept
	500/PARMA(1,1)/SVM-NNM	0.05/0.01	1.645/2.327	-0.136	Accept/ Accept
	1000/PARMA(1,1)/SVM-NNM	0.05/0.01	1.645/2.327	-0.288	Accept/ Accept
Haenam	100/PARMA(1,1)/SVM-NNM	0.05/0.01	1.645/2.327	-0.172	Accept/ Accept
	500/PARMA(1,1)/SVM-NNM	0.05/0.01	1.645/2.327	-0.124	Accept/ Accept
	1000/PARMA(1,1)/SVM-NNM	0.05/0.01	1.645/2.327	-0.076	Accept/ Accept

Table 10. Results of the Mann-Whitney  $U$  test of PE

Station	Training Pattern	Level of Significance	Mann-Whitney $U$ test		
			Critical $z$ Statistic	Computed $z$ Statistic	Null Hypothesis
Gwangju	100/PARMA(1,1)/SVM-NNM	0.05/0.01	1.645/2.327	-0.056	Accept/ Accept
	500/PARMA(1,1)/SVM-NNM	0.05/0.01	1.645/2.327	-0.515	Accept/ Accept
	1000/PARMA(1,1)/SVM-NNM	0.05/0.01	1.645/2.327	-0.711	Accept/ Accept
Haenam	100/PARMA(1,1)/SVM-NNM	0.05/0.01	1.645/2.327	-0.380	Accept/ Accept
	500/PARMA(1,1)/SVM-NNM	0.05/0.01	1.645/2.327	-0.212	Accept/ Accept
	1000/PARMA(1,1)/SVM-NNM	0.05/0.01	1.645/2.327	-0.176	Accept/ Accept

Table 11. Results of the Mann-Whitney  $U$  test of FAO-56 PM  $ET_o$

## 7. Construction of the Bivariate Linear Regression Analysis Model

The bivariate linear regression analysis model (BLRAM) was adopted to calculate FAO-56 PM  $ET_o$  simply using the observed PE and compare the observed PE and the calculated FAO-56 PM  $ET_o$ . The BLRAM is a conventional and universal model, which can calculate FAO-56 PM  $ET_o$  simply using the observed PE for Gwangju and Haenam stations, respectively. The BLRAM consists of two variables; PE as the independent variable  $X_t$  and FAO-56 PM  $ET_o$  as the dependent variable  $Y_t$ . The mathematical expression can be written as the following equation (12) (McCuen, 1993; Salas et al., 2001; Ayyub and McCuen, 2003).

$$Y_t = b_0 + b_1 \cdot X_t \quad (12)$$

where  $b_1$  = the slope coefficient, which is also known as the regression coefficient because it is calculated by the result of a regression analysis. Using the BLRAM, the correlation relationship was investigated between the observed PE and FAO-56 PM  $ET_o$  for 3 training patterns. A very good relationship was found with the BLRAM, which could calculate FAO-56 PM  $ET_o$  in this study. The results of the BLRAM were the same for 3 training patterns. Therefore, it can be considered that the observed PE and FAO-56 PM  $ET_o$  for 3 training patterns are homogeneous groups. It can be inferred from the homogeneity evaluation of the previous chapter.

Table 12 shows the BLRAM, goodness-of-fit test, and regression coefficient between the observed PE and FAO-56 PM  $ET_o$  for 3 training patterns of Gwangju and Haenam stations, respectively. From the Table 12, for Gwangju station, the regression coefficient of the BLRAM indicates that FAO-56 PM  $ET_o$  increases 0.9060 mm as each 1 mm increase in PE.  $R^2 = 0.966$  indicates that the total variance of FAO-56 PM  $ET_o$  corresponds to 96.6%. The ratio of  $S(e)/S(y) = 0.187$  suggests a very good level of accuracy. In addition, the standard error of estimate (SEE) decreases from 37.471 mm ( $S(y)$ ) to 7.007 mm ( $S(e)$ ), where  $S(y)$  = the standard deviation of FAO-56 PM  $ET_o$ ; and  $S(e)$  = the standard error of FAO-56 PM  $ET_o$  using the equation (12). The overall deviations are nearly zero, and this tendency always occurs for the BLRAM. The standard error ratios of the regression coefficient ( $b_1$ ) and the intercept ( $b_0$ ) are 0.023 and 0.911, which indicates that the regression coefficient is relatively more accurate than the intercept. For Haenam station, the regression coefficient of the BLRAM indicates that FAO-56 PM  $ET_o$  increases 0.9574 mm as each 1 mm increase in PE.  $R^2 = 0.919$  indicates that the total variance of FAO-56 PM  $ET_o$  corresponds to 91.9%. The ratio of  $S(e)/S(y) = 0.287$  suggests a very good level of accuracy. In addition, the standard error of estimate (SEE) decreases from 36.794 mm ( $S(y)$ ) to 10.560 mm ( $S(e)$ ), where  $S(y)$  = the standard deviation of FAO-56 PM  $ET_o$ ; and  $S(e)$  = the standard error of FAO-56 PM  $ET_o$  using the equation (12). The overall deviations are nearly zero, and this tendency always occurs for the BLRAM. The standard error ratios of the regression coefficient ( $b_1$ ) and the intercept ( $b_0$ ) are 0.035 and 0.345, which indicates that the regression coefficient is relatively more accurate than the intercept. If a large and negative intercept exists, it can create some problems for forecasting or modeling (McCuen, 1993). Fig. 7(a)-(b) show comparison plots of the observed PE and FAO-56 PM  $ET_o$  for 1000/PARMA(1,1)/SVM-NNM training pattern of Gwangju and Haenam station, respectively.

	BLRAM (3 Training Patterns)	Goodness-of-fit test			Regression coefficient analysis	
		$S(e)$ (mm)	$S(e)/S(y)$	$R^2$	$Se(b_1)/b_1$	$Se(b_0)/b_0$
Gwangju	$ET_o = 0.9060 PE - 2.2901$	7.007	0.187	0.966	0.023	0.911
Haenam	$ET_o = 0.9574 PE - 9.9968$	10.560	0.287	0.919	0.035	0.345

Table 12. Regression analysis between the observed PE and FAO-56 PM  $ET_o$ .

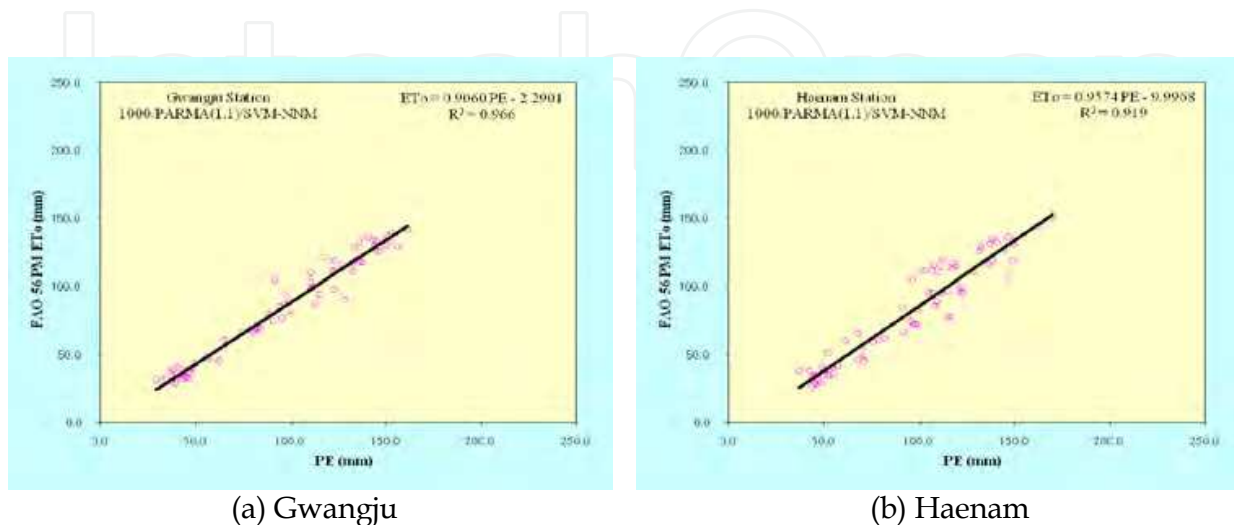

Fig. 7. Comparison plots of the observed PE and FAO-56 PM  $ET_o$ .

## 8. Conclusions

The hybrid method was developed for the modeling of the monthly PE and FAO-56 PM ET<sub>o</sub> simultaneously. The author determined in advance 4 kinds of Univariate Seasonal PARMA(p,q) models including PARMA(1,1), PARMA(1,2), PARMA(2,1), and PARMA(2,2), which are the low-order models and contain the seasonal properties. As a result, the author selected Univariate Seasonal PARMA(1,1) model, which show the best statistical properties and is simple in parameter estimation. The data which were generated by Univariate Seasonal PARMA(1,1) model consisted of 100 years (Short-term), 500 years (Mid-term), and 1000 years (Long-term), respectively. The following conclusions can be drawn from this study.

[1] The statistics results of the testing performance for 100/PARMA(1,1)/SVM-NNM training pattern were better than those of the testing performances for 500/PARMA(1,1)/SVM-NNM and 1000/PARMA(1,1)/SVM-NNM training patterns for PE of Gwangju station. And, the statistics results of the testing performance for 500/PARMA(1,1)/SVM-NNM training pattern were better than those of the testing performances for 100/PARMA(1,1)/SVM-NNM and 1000/PARMA(1,1)/SVM-NNM training patterns for PE of Haenam station, respectively

[2] The statistics results of the testing performance for 100/PARMA(1,1)/SVM-NNM training pattern were better than those of the testing performances for 500/PARMA(1,1)/SVM-NNM and 1000/PARMA(1,1)/SVM-NNM training patterns for FAO-56 PM ET<sub>o</sub> of Gwangju station. And, the statistics results of the testing performance for 1000/PARMA(1,1)/SVM-NNM training pattern were better than those of the testing performances for 100/PARMA(1,1)/SVM-NNM and 500/PARMA(1,1)/SVM-NNM training patterns for FAO-56 PM ET<sub>o</sub> of Haenam station, respectively

[3] Homogeneity evaluation consisted of the One-way ANOVA and the Mann-Whitney *U* test. The null hypothesis, which is the means are equal, was accepted using the One-way ANOVA on the means for PE and FAO-56 PM ET<sub>o</sub> of Gwangju and Haenam stations, respectively. And, the null hypothesis, which is the variances are equal, was accepted using the One-way ANOVA on the variances for PE and FAO-56 PM ET<sub>o</sub> of Gwangju and Haenam stations, respectively. The null hypothesis, which is the two independent samples are from the same population, was accepted using the Mann-Whitney *U* test for PE and FAO-56 PM ET<sub>o</sub> of Gwangju and Haenam stations, respectively.

[4] The BLRAM was adopted to calculate FAO-56 PM ET<sub>o</sub> simply using the observed PE and compare the observed PE and the calculated FAO-56 PM ET<sub>o</sub> of Gwangju and Haenam stations, respectively. A very good relationship was found with the BLRAM, which could calculate FAO-56 PM ET<sub>o</sub>.

As PE and FAO-56 PM ET<sub>o</sub> are relatively important for the design of irrigation facilities and agricultural reservoirs, the spread of an automatic measuring system for PE and FAO-56 PM ET<sub>o</sub> is important and urgent to ensure the reliable and accurate data from the measurements of PE and FAO-56 PM ET<sub>o</sub>. Furthermore, the continuous research will be needed to establish the neural networks models available for the optimal training patterns and modeling of PE and FAO-56 PM ET<sub>o</sub>.

## 9. References

- Allen, R.G.; Jensen, M.E.; Wright, J.L. & Burman, R.D. (1989). Operational estimates of reference evapotranspiration. *Agronomy Journal*, Vol. 81, No. 4, pp. 650-662, ISSN: 0002-1962.

- Allen, R.G.; Pereira, L.S.; Raes, D. & Smith, M. (1998). *Crop evapotranspiration. Guidelines for computing crop water requirement*, Irrigation and Drainage Paper No. 56, FAO, Rome, Italy.
- ASCE Task Committee on Definition of Criteria for Evaluation of Watershed Models. (1993). Criteria for evaluation of watershed models. *Journal of Irrigation and Drainage Engineering, ASCE*, Vol. 119, No. 3, pp. 429-442, ISSN: 0733-9437.
- Ayyub, B.M. & McCuen, R.H. (2003). *Probability, Statistics, and Reliability for Engineers and Scientists 2<sup>nd</sup> Edition*, Taylor & Francis, ISBN: 1584882867, Boca Raton, FL, USA.
- Bishop, C.M. (1994). Neural networks and their applications. *Review of Scientific Instruments*, Vol. 65, pp. 1803-1832, ISSN: 0034-6748.
- Bruton, J.M.; McClendon, R.W. & Hoogenboom, G. (2000). Estimating daily pan evaporation with artificial neural networks. *Transactions of the American Society Agricultural Engineers, ASAE*, Vol. 43, No. 2, pp. 491-496, ISSN:0001-2351.
- Chang, F.J.; Chang, L.C.; Kao, H.S. & Wu, G.R. (2010). Assessing the effort of meteorological variables for evaporation estimation by self-organizing map neural network. *Journal of Hydrology*, Vol. 384, pp. 118-129, ISSN: 0022-1694.
- Choudhury, B.J. (1999). Evaluation of empirical equation for annual evaporation using field observations and results from a biophysical model. *Journal of Hydrology*, Vol. 216, pp. 99-110, ISSN: 0022-1694.
- Cover, T.M. (1965). Geometrical and statistical properties of systems of linear inequalities with applications in pattern recognition. *IEEE Transactions on Electronic Computers EC-14*, pp. 326-334.
- Dibike, Y.B.; Velickov, S.; Solomatine, D. & Abbott, M.B. (2001). Model induction with support vector machines: introductions and applications. *Journal of Computing in Civil Engineering, ASCE*, Vol. 15, No. 3, pp. 208-216, ISSN: 0887-3801.
- Doorenbos, J. & Pruitt, W.O. (1977). *Guidelines for predicting crop water requirement*, Irrigation and Drainage Paper No. 24 2<sup>nd</sup> Edition, FAO, Rome, Italy.
- Finch, J.W. (2001). A comparison between measured and modeled open water evaporation from a reservoir in south-east England. *Hydrological Processes*, Vol. 15, pp. 2771-2778, ISSN: 0885-6087.
- Güven, A. & Kisi, O. (2011). Daily pan evaporation modeling using linear genetic programming technique. *Irrigation Science*, Vol. 29, No. 2, pp. 135-145, ISSN: 0342-7188.
- Haykin, S. (2009). *Neural networks and learning machines 3<sup>rd</sup> Edition*, Prentice Hall, ISBN: 0131471392, NJ, USA.
- Hirsch R.M. (1979). Synthetic hydrology and water supply reliability. *Water Resources Research*, Vol. 15, pp.1603-1615, ISSN: 0043-1397.
- Hush, D.R. & Horne, B.G. (1993). Progress in supervised neural network : What's new since Lippmann ?. *IEEE Signal Processing Magazine*, Vol. 10, pp. 8-39, ISSN: 1053-5888.
- Jain, S.K.; Nayak, P.C. & Sudheer, K.P. (2008). Models for estimating evapotranspiration using artificial neural networks, and their physical interpretation. *Hydrological Processes*, Vol. 22, pp. 2225-2234, ISSN: 0885-6087.
- Jensen, M.E.; Burman, R.D. & Allen, R.G. (1990). *Evapotranspiration and irrigation water requirements*, ASCE Manual and Report on Engineering Practice No. 70, ASCE, NY, USA.
- Keskin, M.E. & Terzi, O. (2006). Artificial neural networks models of daily pan evaporation. *Journal of Hydrologic Engineering, ASCE*, Vol. 11, No. 1, pp. 65-70, ISSN: 1084-0699.



- Khadam, I.M. & Kaluarachchi, J.J. (2004). Use of soft information to describe the relative uncertainty of calibration data in hydrologic models. *Water Resources Research*, Vol. 40, No. 11, W11505, ISSN: 0043-1397.
- Kim, S. (2004). Neural Networks Model and Embedded Stochastic Processes for Hydrological Analysis in South Korea. *KSCE Journal of Civil Engineering*, Vol. 8, No. 1, pp. 141-148, ISSN: 1226-7988.
- Kim, S. (2011). Nonlinear hydrologic modeling using the stochastic and neural networks approach. *Disaster Advances*, Vol. 4, No. 1, pp. 53-63, ISSN: 0974-262X.
- Kim, S.; Kim, J.H. & Park, K.B. (2009). Neural networks models for the flood forecasting and disaster prevention system in the small catchment. *Disaster Advances*, Vol. 2, No. 3, pp. 51-63, ISSN: 0974-262X.
- Kim, S. & Kim, H.S. (2008). Neural networks and genetic algorithm approach for nonlinear evaporation and evapotranspiration modeling. *Journal of Hydrology*, Vol. 351, pp. 299-317, ISSN: 0022-1694.
- Kisi, O. (2006). Generalized regression neural networks for evapotranspiration modeling. *Hydrological Sciences Journal*, Vol. 51, No. 6, pp. 1092-1105, ISSN: 0262-6667.
- Kisi, O. (2007). Evapotranspiration modeling from climatic data using a neural computing technique. *Hydrological Processes*, Vol. 21, pp. 1925-1934, ISSN: 0885-6087.
- Kisi, O. (2009). Modeling monthly evaporation using two different neural computing technique. *Irrigation Science*, Vol. 27, No. 5, pp. 417-430, ISSN: 0342-7188.
- Kisi, O. & Ozturk, O. (2007). Adaptive neurofuzzy computing technique for evapotranspiration estimation. *Journal of Irrigation and Drainage Engineering, ASCE*, Vol. 133, No. 4, pp. 368-379, ISSN: 0733-9437.
- Kumar, M.; Bandyopadhyay, A.; Raghuwanshi, N.S. & Singh, R. (2008). Comparative study of conventional and artificial neural network-based  $ET_o$  estimation models. *Irrigation Science*, Vol. 26, No. 6, pp. 531-545, ISSN: 0342-7188.
- Kumar, M.; Raghuwanshi, N.S. & Singh, R. (2009). Development and validation of GANN model for evapotranspiration estimation. *Journal of Hydrologic Engineering, ASCE*, Vol. 14, No. 2, pp. 131-140, ISSN: 1084-0699.
- Kumar, M.; Raghuwanshi, N.S.; Singh, R.; Wallender, W.W. & Pruitt, W.O. (2002). Estimating evapotranspiration using artificial neural network. *Journal of Irrigation and Drainage Engineering, ASCE*, Vol. 128, No. 4, pp. 224-233, ISSN: 0733-9437.
- Landeras, G.; Ortiz-Barredo, A. & Lopez, J.J. (2008). Comparison of artificial neural network models and empirical and semi-empirical equations for daily reference evapotranspiration estimation in the Basque country (Northern Spain). *Agricultural Water Management*, Vol. 95, No. 5, pp. 553-565, ISSN: 0378-3774.
- McCuen, R.H. (1993). *Microcomputer applications in statistical hydrology*, Prentice Hall, ISBN: 0135852900, Englewood Cliffs, NJ, USA.
- McKenzie, R.S. & Craig, A.R. (2001). Evaluation of river losses from the Orange River using hydraulic modeling. *Journal of Hydrology*, Vol. 241, pp. 62-69, ISSN: 0022-1694.
- Mishra, A.K.; Desai, V.R. & Singh, V.P. (2007). Drought forecasting using a hybrid stochastic and neural network model. *Journal of Hydrologic Engineering, ASCE*, Vol. 12, No. 6, pp. 626-638, ISSN: 1084-0699.
- Monteith, J.L. (1965). The state and movement of water in living organism, *Proceedings of Evaporation and Environment*, pp. 205-234, Swansea, Cambridge University Press, NY, USA.

- Nash, J.E. & Sutcliffe, J.V. (1970). River flow forecasting through conceptual models, Part 1 - A discussion of principles. *Journal of Hydrology*, Vol. 10, No. 3, pp. 282-290, ISSN: 0022-1694.
- Penman, H.L. (1948). Natural evaporation from open water, bare soil and grass, *Proceedings of the Royal Society of London*, Vol. 193, pp. 120-146, London, England.
- Principe, J.C.; Euliano, N.R. & Lefebvre, W.C. (2000). *Neural and adaptive systems: fundamentals through simulation*, Wiley, John & Sons, ISBN: 0471351679, NY, USA.
- Rosenberry, D.O.; Winter, T.C.; Buso, D.C. & Likens, G.E. (2007). Comparison of 15 evaporation methods applied to a small mountain lake in the northeastern USA. *Journal of Hydrology*, Vol. 340, pp. 149-166, ISSN: 0022-1694.
- Salas, J.D. (1993). Analysis and modeling of hydrologic time series. In: *Handbook of Hydrology, Chapter 19*, Maidment, D.R., (Ed.), pp. 19.1-19.72, McGraw-Hill, ISBN: 0070397325, NY, USA.
- Salas, J.D. & Abdelmohsen, M. (1993). Initialization for generating single site and multisite low order PARMA processes. *Water Resources Research*, Vol.29, pp.1771-1776, ISSN: 0043-1397.
- Salas J.D.; Boes D.C.; & Smith, R.A. (1982). Estimation of ARMA models with seasonal parameters. *Water Resources Research*, Vol. 18, pp.1006-1010, ISSN: 0043-1397.
- Salas J.D.; Delleur J.R.; Yevjevich, V & Lane, W.L. (1980). *Applied modeling of hydrologic time series*, Water Resources Publication, ISBN: 0918334373, CO, USA.
- Salas, J.D.; Smith, R.A., Tabios III, G.O. & Heo, J.H. (2001). *Statistical computing techniques in water resources and environmental engineering*, Unpublished book in CE622, Colorado State University, Fort Collins, CO, USA.
- Shiri, J. & Kisi, O. (2011). Application of artificial intelligence to estimate daily pan evaporation using available and estimated climatic data in the Khozestan Province (Southwestern Iran). *Journal of Irrigation and Drainage Engineering, ASCE*, Vol. 137, No. 7, pp. 412-425, ISSN: 0733-9437.
- Singh, V.P. (1988). *Hydrologic system rainfall-runoff modeling. Vol. 1*, Prentice Hall, ISBN: 0134480511, NJ, USA.
- Sivakumar B.; Jayawardena, A.W. & Fernando, T.M.K.G. (2002). River flow forecasting : use of phase-space reconstruction and artificial neural networks approaches. *Journal of Hydrology*, Vol. 265, pp. 225-245, ISSN: 0022-1694
- Sudheer, K.P.; Gosain, A.K.; Rangan, D.M. & Saheb, S.M. (2002). Modeling evaporation using an artificial neural network algorithm. *Hydrological Processes*, Vol. 16, pp. 3189-3202, ISSN: 0885-6087.
- Sudheer, K.P.; Gosain, A.K. & Ramasastri, K.S. (2003). Estimating actual evapotranspiration from limited climatic data using neural computing technique. *Journal of Irrigation and Drainage Engineering, ASCE*, Vol. 129, No. 3, pp. 214-218, ISSN: 0733-9437.
- Tabari, H.; Marofi, S. & Sabziparvar, A.A. (2009). Estimation of daily pan evaporation using artificial neural network and multivariate non-linear regression. *Irrigation Science*, Vol. 28, No. 5, pp. 399-406, ISSN: 0342-7188.
- Tao, P.C. & Delleur, J.W. (1976). Seasonal and nonseasonal ARMA models in hydrology. *Journal of Hydraulic Division, ASCE*, Vol. 102, pp.1591-1599, ISSN: 0733-9429.
- Tokar, A.S. & Johnson, P.A. (1999). Rainfall-runoff modeling using artificial neural networks. *Journal of Hydrologic Engineering, ASCE*, Vol. 4, No. 3, pp. 232-239, ISSN: 1084-0699.

- Trajkovic, S. (2005). Temperature-based approaches for estimating reference evapotranspiration. *Journal of Irrigation and Drainage Engineering, ASCE*, Vol. 131, No. 4, pp. 316-323, ISSN: 0733-9437.
- Trajkovic, S.; Todorovic, B. & Stankovic, M. (2003). Forecasting reference evapotranspiration by artificial neural networks. *Journal of Irrigation and Drainage Engineering, ASCE*, Vol. 129, No. 6, pp. 454-457, ISSN: 0733-9437.
- Tripathi, S.; Srinivas, V.V. & Nanjundish, R.S. (2006). Downscaling of precipitation for climate change scenarios: A support vector machine approach. *Journal of Hydrology*, Vol. 330, pp. 621-640, ISSN: 0022-1694.
- Vallet-Coulomb, C.; Legesse, D.; Gasse, F.; Travi, Y. & Chernet, T. (2001). Lake evaporation estimates in tropical Africa (Lake Ziway, Ethiopia). *Journal of Hydrology*, Vol. 245, pp. 1-18, ISSN: 0022-1694.
- Vapnik, V.N. (1992). Principles of risk minimization for learning theory. In: *Advances in Neural Information Processing Systems Vol. 4*, Moody, Hanson & Lippmann, (Ed.), pp. 831-838, Elsevier, ISBN: 1558602224, NY, USA.
- Vapnik, V.N. (2010). *The nature of statistical learning theory 2<sup>nd</sup> Edition*, Springer-Verlag, ISBN: 0387987800, NY, USA.
- Zanetti, S.S.; Sousa, E.F.; Oliveira, V.P.S.; Almeida, F.T. & Bernardo, S. (2007). Estimating evapotranspiration using artificial neural network and minimum climatological data. *Journal of Irrigation and Drainage Engineering, ASCE*, Vol. 133, No. 2, pp. 83-89, ISSN: 0733-9437.

IntechOpen

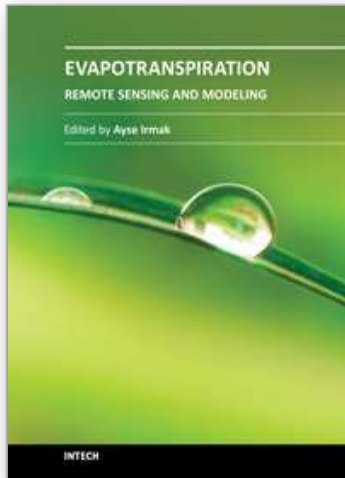

## **Evapotranspiration - Remote Sensing and Modeling**

Edited by Dr. Ayse Irmak

ISBN 978-953-307-808-3

Hard cover, 514 pages

**Publisher** InTech

**Published online** 18, January, 2012

**Published in print edition** January, 2012

This edition of Evapotranspiration - Remote Sensing and Modeling contains 23 chapters related to the modeling and simulation of evapotranspiration (ET) and remote sensing-based energy balance determination of ET. These areas are at the forefront of technologies that quantify the highly spatial ET from the Earth's surface. The topics describe mechanics of ET simulation from partially vegetated surfaces and stomatal conductance behavior of natural and agricultural ecosystems. Estimation methods that use weather based methods, soil water balance, the Complementary Relationship, the Hargreaves and other temperature-radiation based methods, and Fuzzy-Probabilistic calculations are described. A critical review describes methods used in hydrological models. Applications describe ET patterns in alpine catchments, under water shortage, for irrigated systems, under climate change, and for grasslands and pastures. Remote sensing based approaches include Landsat and MODIS satellite-based energy balance, and the common process models SEBAL, METRIC and S-SEBS. Recommended guidelines for applying operational satellite-based energy balance models and for overcoming common challenges are made.

### **How to reference**

In order to correctly reference this scholarly work, feel free to copy and paste the following:

Sungwon Kim (2012). Development of Hybrid Method for the Modeling of Evaporation and Evapotranspiration, Evapotranspiration - Remote Sensing and Modeling, Dr. Ayse Irmak (Ed.), ISBN: 978-953-307-808-3, InTech, Available from: <http://www.intechopen.com/books/evapotranspiration-remote-sensing-and-modeling/development-of-hybrid-method-for-the-modeling-of-evaporation-and-evapotranspiration>

**INTECH**  
open science | open minds

### **InTech Europe**

University Campus STeP Ri  
Slavka Krautzeka 83/A  
51000 Rijeka, Croatia  
Phone: +385 (51) 770 447  
Fax: +385 (51) 686 166  
[www.intechopen.com](http://www.intechopen.com)

### **InTech China**

Unit 405, Office Block, Hotel Equatorial Shanghai  
No.65, Yan An Road (West), Shanghai, 200040, China  
中国上海市延安西路65号上海国际贵都大饭店办公楼405单元  
Phone: +86-21-62489820  
Fax: +86-21-62489821

© 2012 The Author(s). Licensee IntechOpen. This is an open access article distributed under the terms of the [Creative Commons Attribution 3.0 License](#), which permits unrestricted use, distribution, and reproduction in any medium, provided the original work is properly cited.

IntechOpen

IntechOpen