

# We are IntechOpen, the world's leading publisher of Open Access books Built by scientists, for scientists

**4,800**

Open access books available

**122,000**

International authors and editors

**135M**

Downloads

Our authors are among the

**154**

Countries delivered to

**TOP 1%**

most cited scientists

**12.2%**

Contributors from top 500 universities



**WEB OF SCIENCE™**

Selection of our books indexed in the Book Citation Index  
in Web of Science™ Core Collection (BKCI)

Interested in publishing with us?  
Contact [book.department@intechopen.com](mailto:book.department@intechopen.com)

Numbers displayed above are based on latest data collected.

For more information visit [www.intechopen.com](http://www.intechopen.com)



## A DSP Practical Application: Working on ECG Signal

Cristian Vidal Silva<sup>1</sup>, Andrew Philominraj<sup>2</sup> and Carolina del Río<sup>3</sup>

<sup>1</sup>University of Talca, Business Informatics Administration

<sup>2</sup>University of Talca, Language Program

<sup>3</sup>University of Talca, Business Administration  
Chile

### 1. Introduction

An electrocardiogram (ECG) is a graphical record of bioelectrical signal generated by the human body during cardiac cycle (Goldschlager, 1989). ECG graphically gives useful information that relates to the heart functioning (Dubis, 1976) by means of a base line and waves representing the heart voltage changes during a period of time, usually a short period (Cuesta, 2001).

Putting leads on specific part of the human body, it is possible to get changes of the bioelectrical heart signal (Goldschlager, 1989) where one of the most basic forms of organizing them is known as Einthoven lead system which is shown in Figure 1 (Vidal & Pavesi, 2004; Vidal et al., 2008).

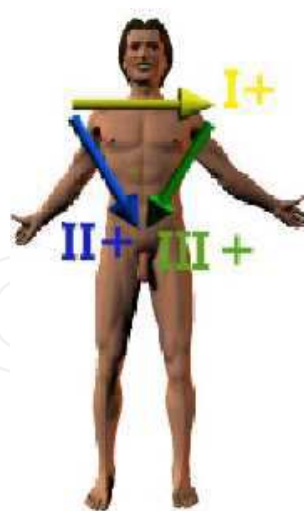

Fig. 1. Einthoven lead system

#### 1.1 ECG usefulness

The ECG has a special value in the following clinical situations (Goldschlager, 1989):

- Auricular and ventricular hypertrophy.
- Myocardial Infarction (heart attack).

- Arrhythmias.
- Pericarditis.
- Generalized suffering affecting heart and blood pressure.
- Cardiac medicine effects, especially digital and quinidine.
- Electrolytic transformations.

In spite of the special value, the ECG is considered only a laboratory test. It is not an absolute truth concerning the cardiac pathologies diagnosis. There are examples of patients presenting string heart diseases which present a normal ECG, and also perfectly normal patients getting an abnormal ECG (Goldschlager, 1989). Therefore, an ECG must always be interpreted with the patient clinical information.

## 2. Electrocardiographic signal

According to (Proakis & Manolakis, 2007) a signal can be analyzed and processed in two domains, time and frequency. ECG signal is one of the human body signals which can be analyzed and worked in these two domains.

### 2.1 Time domain of an ECG signal

P, Q, R, S, T and U are specific wave forms identified in the time domain of an ECG signal. The QRS complex, formed by Q, R and S waves, represents a relevant wave form because the heart rate can be identified locating two successive QRS complex. Figure 2 presents typical waves in an ECG signal.

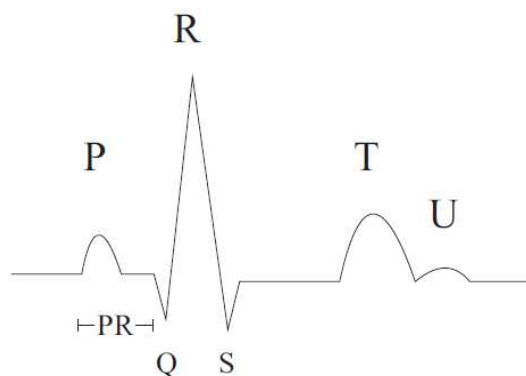

Fig. 2. Typical wave forms of an ECG signal record

### 2.2 Frequency domain of an ECG signal

Frequency values of an ECG signal vary from 0 Hz to 100 Hz (Cuesta, 2001; Vidal & Pavesi, 2004; Vidal et al., 2008; Vidal & Gatica, 2010) whereas the associated amplitude values vary from 0.02 mV to 5 mV. Table 1 describes the frequency and amplitude values of ECG, EMG (electromiogram), and EEG (electroencephalogram) signals.

Signal	Amplitude (mV)	Frequency range (Hz)
ECG	0.02 - 5.0	0.05 - 100
EEG	0.0002 - 0.3	DC - 150
EMG	0.1 - 5.0	DC - 10000

Table 1. Amplitude and Frequency Range of Basic Bioelectrical Signals of the Human Being

As it is appreciated, the amplitude values of human body bioelectrical signals are measured in micro volts (mV). Furthermore, the amplitude values of these signals are small voltage values and are being caught using traditional electronic devices. This is an important characteristic which must be considered to implement an electronic device in order to obtain bioelectrical signals.

There are different sources of noise at the moment of getting a human body signal. The frequency domain helps us to know of how additional sources affect the important signal in the time domain.

Figure 3 shows frequency range of QRS complex of an ECG signal next to the frequency range of common noise sources.

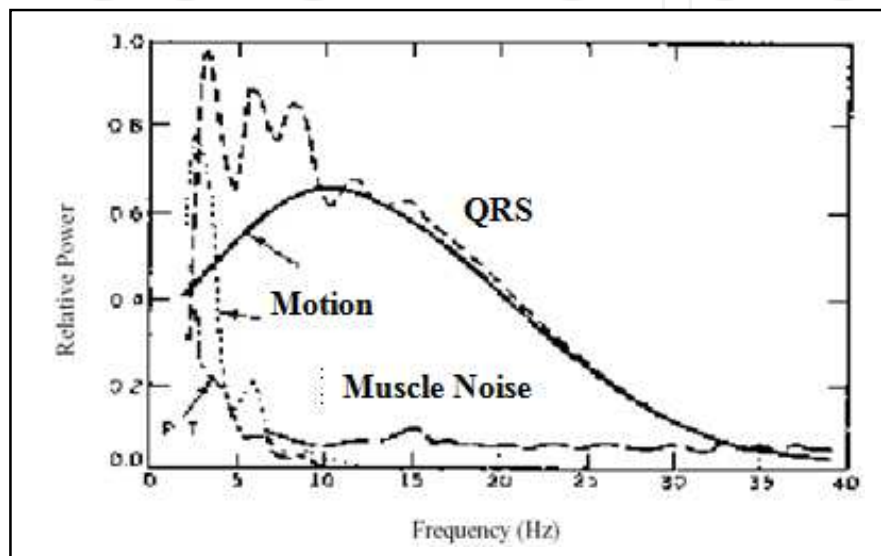

Fig. 3. Frequency range of QRS complex on an ECG signal next to noise sources (Vidal et al., 2008)

### 3. Digital ECG

Building a device to get and process the ECG signal must consider the signal characteristics. According to (Cuesta, 2001; Vidal & Pavesi, 2004), facing individually each part of the global problems is a technique applicable in order to get good practical results.

Figure 4 presents each part or block of a basic digital ECG according to reviewed literature

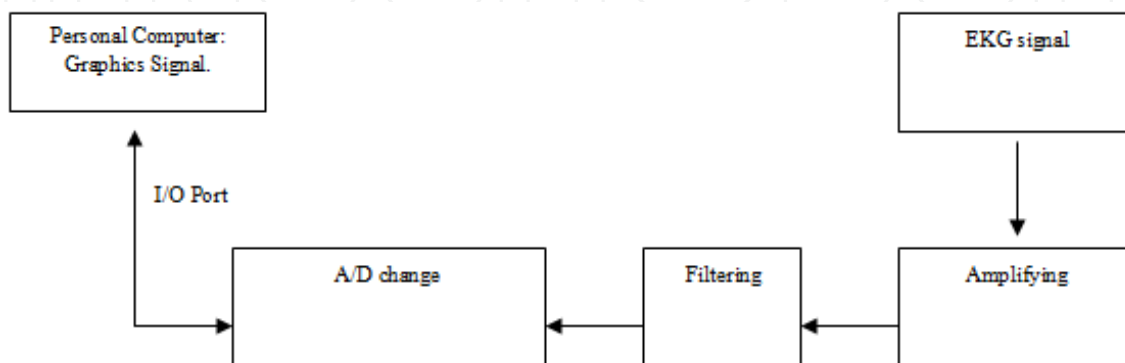

Fig. 4. Blocks Diagram of a Basic Digital ECG.

(Cuesta, 2001; Vidal et al., 2008; Vidal & Gatica, 2010) where the most important part corresponds to the amplifying module because of a bioelectrical signal that represents a low potential, and sophisticated amplifiers are required for obtaining and recording it (Vidal & Pavesi, 2004; Vidal et al., 2008; Vidal & Gatica, 2010).

The following sections present experiences building a device for getting the ECG signal, and works related to processing ECG signal.

### 3.1 Digital ECG design

Signals produced by bioelectric phenomenon are small potential values and due to this, sophisticated amplifiers are required so as to easily obtain signal values (Vidal & Pavesi, 2004).

Against a physiologic backdrop, these ionic signals are transmitted at a fast-rate without synaptic delay in both direction directed by the electric synapse transmission model. This electric potential is later transformed in a mechanical signal as of using calcium ion that comes from extracellular condition which is also useful for cooking calcium that is released from the internal section of cardiac cells provoking a massive cardiac muscle like a sincitio or functional unit (Clusin, 2008). In this sense, the main finality of an amplifier is to increment the measurable level of the gotten signal by electrodes, avoiding any kind of interference. The capacitive interference of the patient body, electrical fields of electric installations, and other environment electronic devices are examples of interference or noise. (Proakis & Manolakis, 2007) indicate that the quantification can be done using single pole configurations or bipolar. In the single pole quantification, difference between a signal and a common base is measured whereas the bipolar mode measures the difference of two voltage sources (two electrodes) with respect to a common base where any interference voltage generated at the quantification point appears at the amplifier input as common-mode interference signals. Figure 5 illustrates this phenomenon in a bipolar quantification.

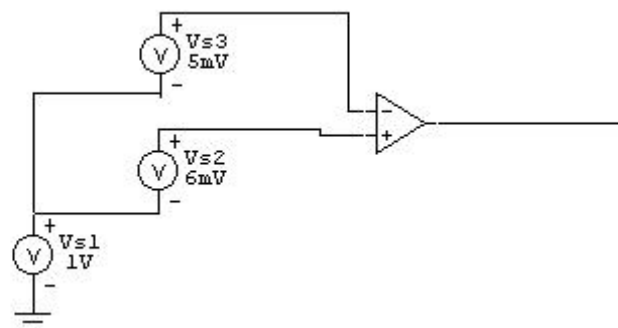

Fig. 5. Common-Mode Interferences in a bipolar quantification

A strong source noise which interferes on the ECG signal is the capacitive interference of the patient body. This interference voltage is coupled to the ECG signal reaching values of 2.4 V approximately. A value which is very higher than the ECG signals value range (0.02 mV to 5 mV). In addition to this interference, the capacitive interference due to the equipment or device used to measure the ECG signal which is produced by the equipment power supply. Another noise source is the denominated inductive interference that is caused by the electric net which produces variable in time magnetic fields inducing extra voltages on the next of patient electrodes (Townsend, 2001).

For these reasons, common mode rejection ratio (CMRR) rate is a desirable characteristic of an amplifier working on differential mode. On a day today practice, a problem denominated contact impedance disbalance appears (Townsend, 2001) that is produced when there are different interfaces impedances between the skin and electrodes in a form that the common-mode potential is higher in one of the two voltage sources. Therefore, part of the common-mode voltage is worked as differential voltage and amplified according to the amplifier gain. This occasionally produces saturation on the next amplifying module stage, if the amplification module were composed by more stages. This voltage, which is generally continuous, can be eliminated using a simple high-pass filter. Hence, the output voltage of the differential amplifier would consist of 3 components (Townsend, 2001; Vidal & Pavesi, 2004):

- Wished output due to the differential amplification on the ECG signal.
- Common-mode signal not wished due to the CMRR is not infinite.
- Common-mode signal not wished due to the disbalance on the impedance contact.

(Wells & Crampton, 2006) indicate that weak signals require an amplification of 1000 at least to produce adequate signal levels for future works on it. (Vidal & Pavesi, 2004) used an instrument amplifier model INA131 which presents a fixed CMRR of 100, and according to the associated datasheet it is adequate for biomedical instrumentation. The analog to digital conversion stage (A/D conversion) is always done when the signal is amplified. The electronic schemes of a digital electrocardiographic device according to (Vidal & Gatica, 2010) are presented on figures 6 and 7, respectively. (Vidal & Pavesi, 2004; Vidal & Gatica, 2010) use the TLC1541 A/D converter. It is necessary to indicate that both electronic items, INA131 and TLC1541, are less expensive.

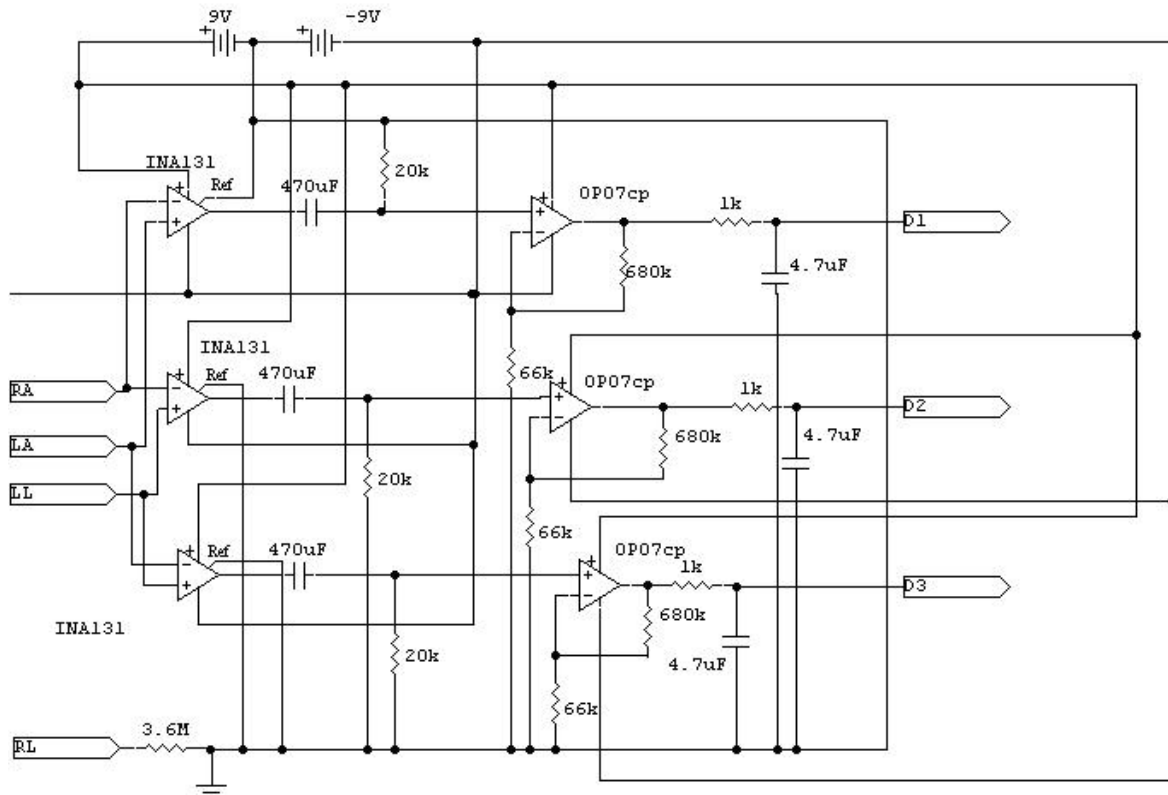

Fig. 6. ECG Signal Amplifying Module Circuit



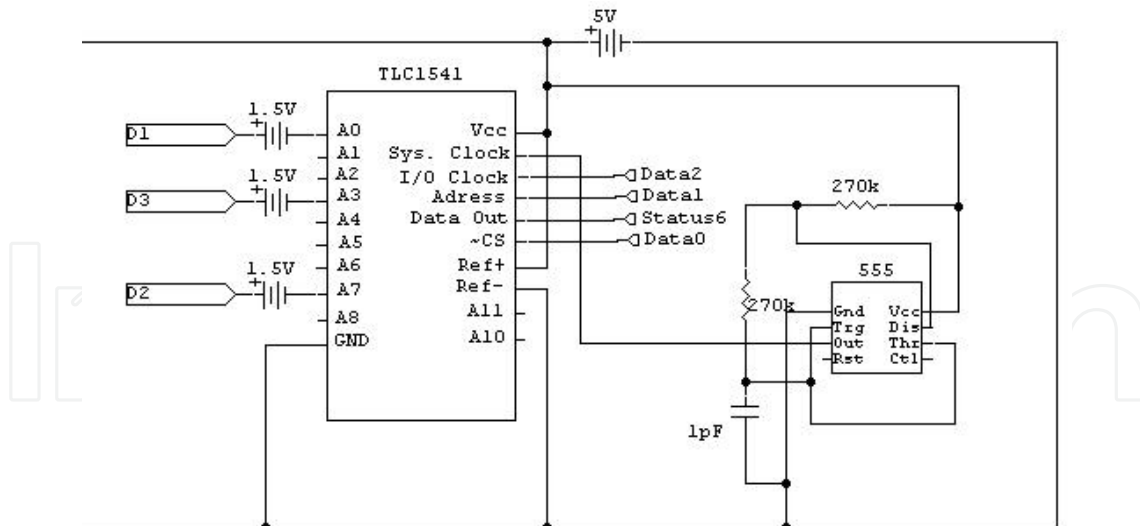

Fig. 7. Data Acquisition Module Circuit

### 3.2 Acquiring and processing ECG signal

The acquisition data stage has a hardware part composed by the A/D converter, and a software part which is in charge of directing the A/D converter work. Any programming language allowing low level hardware instruction is usable. (Vidal & Pavesi, 2004) and (Vidal & Gatica, 2010) describe the use of C and Visual Basic programming languages for getting and processing the ECG signal. According to these works, the routine written in C language is used to direct the A/D converter functioning using non-standard functions to access the personal computer ports. The obtained quantity of samples is stored in a binary file which is rescued by the Visual Basic programming language routine to processing (applying filters and QRS detection algorithms) and showing the signal. Showing the signal at the computer is done "off-line" from the generated file with the ECG signal samples. As (Vidal & Gatica, 2010) highlights using current high level programming languages would be possible to build a showing graphics routine. Using lineal interpolation it is possible to get high level graphic results. Even though the Nyquist's sample theorem indicates that a signal can be rebuild using an ideal interpolation method (Lindner, 2009; Proakis & Manolakis 2007), by means of lineal interpolation, and through this it is possible to get good results for low frequency signals like ECG. It is possible to build a universal graphics generator for getting signals (Vidal & Pavesi, 2004; Vidal & Gatica, 2010). Figures 8 and 9 present a universal graphics generator for a sine curve signal and a triangle signal, respectively. These signals are low frequency signals (2 Hz) generated by a function or electrical waves generator with some acquisition deformities (high negative values are not considered). Figure 10 shows a pure ECG signal got by means of an implemented ECG system (Vidal & Gatica, 2010).

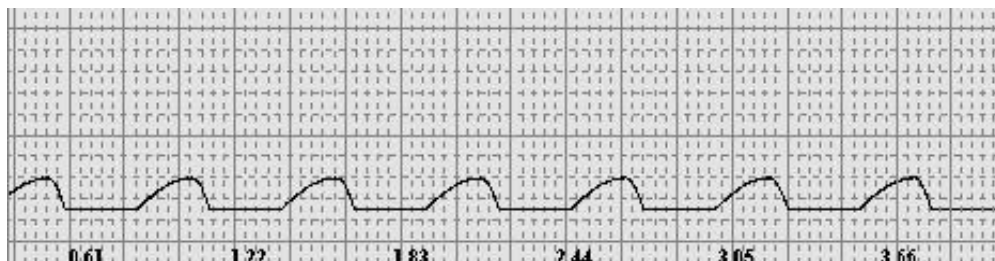

Fig. 8. Sine Signal obtained by the A/D Change Module

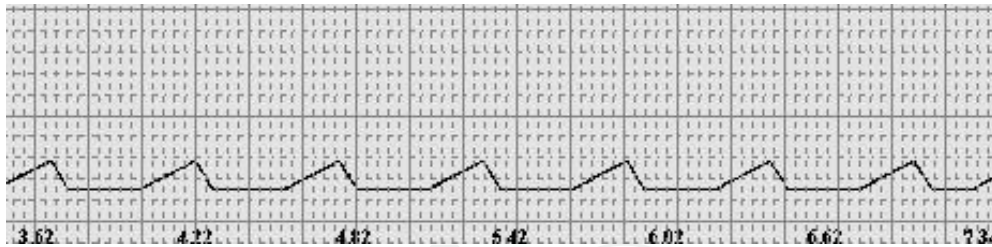

Fig. 9. Triangle Signal obtained by the A/D Change Module

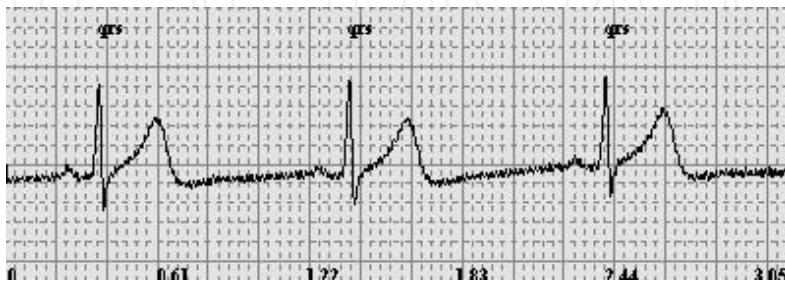

Fig. 10. ECG Signal obtained by the A/D Change Module

## 4. ECG signal processing

(Vidal & Pavesi, 2004; Vidal & Gatica, 2010) worked on the digital filters application to eliminate noise on an ECG signal, and the use of algorithms for QRS complex detecting. Following subsections describe digital filters to work on the ECG signal, and present the main principles of a QRS detector algorithm (Vidal et al., 2008).

### 4.1 Digital filters for ECG signal

To work the ECG signal it is necessary to apply digital filters which helps to diminish the noise present on it. One of the most useful filters is Lynn's filters (Goldschlager, 1989) and there are previous works where Lynn's filters are successfully applied to processing ECG signal (Thakor et al., 1984; Kohler et al., 2002; Ahlstrom & Tompkins, 1985). These filters present desirable properties of real-time filters like lineal phase and integer coefficients. There are low-pass and high-pass Lynn's filters versions which are described as follows.

#### 4.1.1 Low-pass filter

Lynn's filters described in (Ahlstrom & Tompkins, 1985) and used on ECG signal processing in (Pan & Tompkins, 1985; Hamilton & Tompkins, 1986), represent a simple and effective form of applying low-pass filter on ECG signals. These filters obey the next transfer function:

$$H(z) = \frac{(1 - z^{-\alpha})^2}{(1 - z^{-1})^2} = \frac{(1 - 2z^{-\alpha} + z^{-2\alpha})}{(1 - 2z^{-1} + z^{-2})} \quad (1)$$

This filter can be implemented by means of the following differences equation:

$$y[n] = 2y[n-1] - y[n-2] + x[n] - 2x[n-\alpha] + x[n-2\alpha] \quad (2)$$



The amplitude answer of this filter is calculated as follows:

$$H(\omega) = \frac{1 - 2 \cos \alpha \omega + \cos 2\alpha \omega + j(2 \operatorname{sen} \alpha \omega - \operatorname{sen} 2\alpha \omega)}{1 - 2 \cos \omega + \cos 2\omega + j(2 \operatorname{sen} \omega - \operatorname{sen} 2\omega)} = \frac{|\cos \alpha \omega - 1|}{|\cos \omega - 1|} = \frac{\operatorname{sen}^2\left(\frac{\alpha}{2} \omega\right)}{\operatorname{sen}^2\left(\frac{\omega}{2}\right)} \quad (3)$$

For a sample frequency of 430 Hz, possible  $\alpha$  values and associated cut frequency (-3 dB.) are shown in Table 2. Figures 11, 12, and 13 show associated amplitude response for these filters.

$\alpha$ Value	Cut Frequency
3	48 Hz
4	35 Hz
12	11.46 Hz

Table 2. Cut Frequencies of Low-Pass Lynn Filter

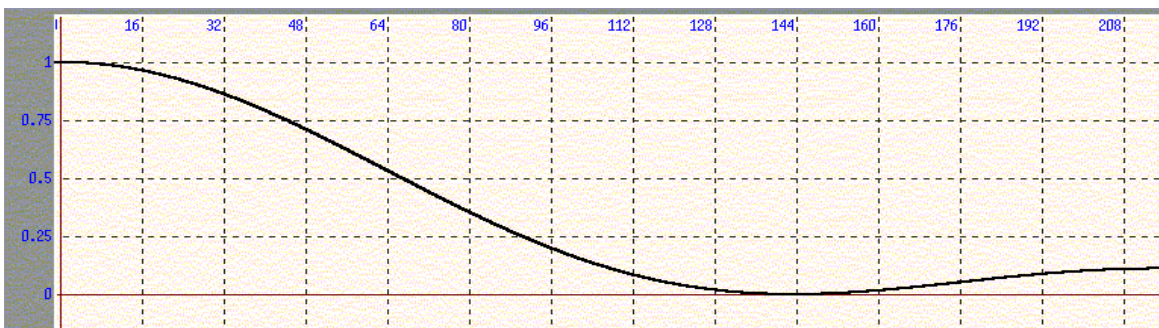

Fig. 11. Amplitude Response of Low-Pass Lynn's Filter for  $\alpha=3$

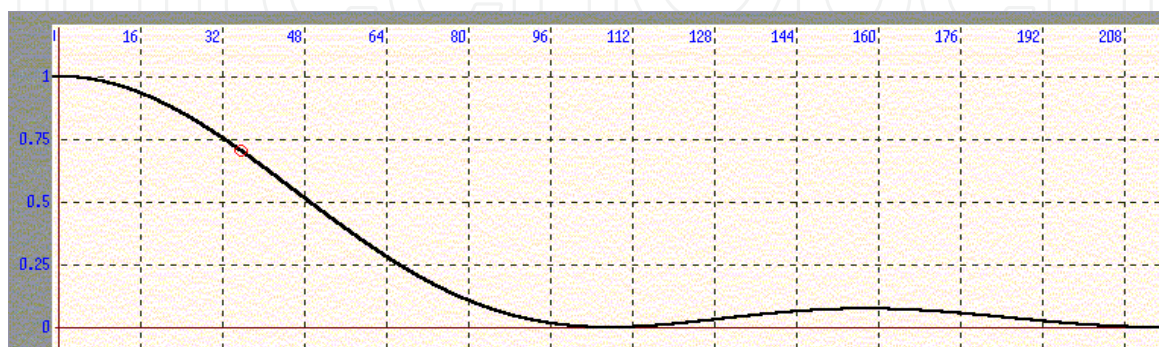

Fig. 12. Amplitude Response of Low-Pass Lynn's Filter for  $\alpha=4$

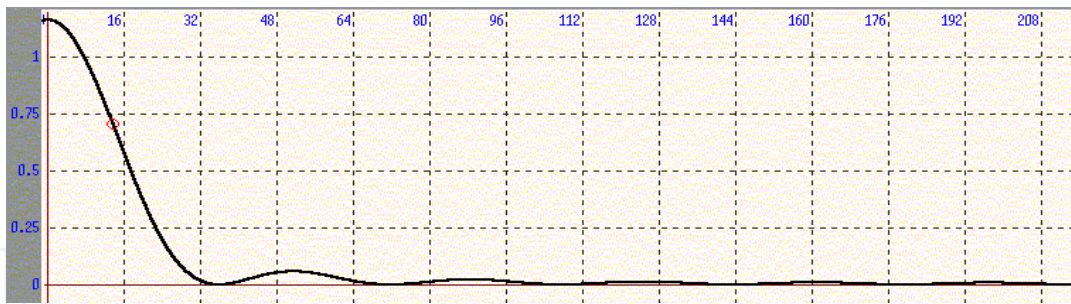

Fig. 13. Amplitude Response of Low-Pass Lynn’s Filter for  $\alpha=5$

### 4.1.2 High pass filters

Like a low-pass Lynn’s filters, there are high-pass Lynn’s filters which are described in (Ahlfstrom & Tompkins, 1985) and applied to ECG signal processing on (Pan & Tompkins, 1985; Hamilton & Tompkins, 1986). These filters are designed using an all-pass filter and resting over it a low-pass filter, and the result is a high-pass filter (Vidal & Pavesi, 2004). However for an effective design, low-pass filter and all-pass filter must be in phase (Smith, 1999).

The High-Pass Lynn’s filter starts using the following low-pass filter transfer equation:

$$H(z) = \frac{(1 - z^{-\alpha})}{(1 - z^{-1})} \tag{4}$$

Amplitude and phase responses are got by:

$$\begin{aligned}
 H(\omega) &= \frac{(1 - e^{-j\alpha\omega})}{(1 - e^{-j\omega})} = \frac{1 - \cos \alpha\omega + j \text{sen} \alpha\omega}{1 - \cos \omega + j \text{sen} \omega} = \\
 &= \frac{2 \text{sen}^2 \frac{\alpha\omega}{2} + j 2 \text{sen} \frac{\alpha\omega}{2} \cos \frac{\alpha\omega}{2}}{2 \text{sen}^2 \frac{\omega}{2} + j 2 \text{sen} \frac{\omega}{2} \cos \frac{\omega}{2}} = \\
 &= \frac{\text{sen} \frac{\alpha\omega}{2} \left( \text{sen} \frac{\alpha\omega}{2} + j \cos \frac{\alpha\omega}{2} \right)}{\text{sen} \frac{\omega}{2} \left( \text{sen} \frac{\omega}{2} + j \cos \frac{\omega}{2} \right)} = \\
 &= \frac{\text{sen} \frac{\alpha\omega}{2} \left( \text{sen} \frac{\alpha\omega}{2} + j \cos \frac{\alpha\omega}{2} \right) \left( \text{sen} \frac{\omega}{2} - j \cos \frac{\omega}{2} \right)}{\text{sen} \frac{\omega}{2} \left( \text{sen} \frac{\omega}{2} + j \cos \frac{\omega}{2} \right) \left( \text{sen} \frac{\omega}{2} - j \cos \frac{\omega}{2} \right)} = \\
 &= \frac{\text{sen} \frac{\alpha\omega}{2} \left[ \left( \text{sen} \frac{\alpha\omega}{2} \text{sen} \frac{\omega}{2} + \cos \frac{\alpha\omega}{2} \cos \frac{\omega}{2} \right) - j \left( \text{sen} \frac{\alpha\omega}{2} \cos \frac{\omega}{2} - \text{sen} \frac{\omega}{2} \cos \frac{\alpha\omega}{2} \right) \right]}{\text{sen} \frac{\omega}{2}} = \\
 &= \frac{\text{sen} \frac{\alpha\omega}{2} \left( \cos \left( \frac{\omega}{2} (\alpha - 1) \right) - j \text{sen} \left( \frac{\omega}{2} (\alpha - 1) \right) \right)}{\text{sen} \frac{\omega}{2}}
 \end{aligned} \tag{5}$$

Finally, amplitude and phase responses are showed on Eq. 6 and Eq. 7, respectively.

$$|H(\omega)| = \left| \frac{\text{sen} \frac{\alpha\omega}{2}}{\text{sen} \frac{\omega}{2}} \right| \quad (6)$$

$$\Theta(\omega) = -\frac{\omega}{2}(\alpha - 1) \quad (7)$$

The filter's group delay is  $(\alpha - 1)/2$ , and the associated gain for  $\omega=0$  is  $\alpha$  determined evaluating  $|H(\omega=0)|$ .

Once completely characterized the low-pass filter, designing the high-pass filter is an easy task using the following transfer function:

$$H(z) = z^{\frac{-(\alpha-1)}{2}} - \left( \frac{1-z^{-\alpha}}{1-z^{-1}} \right) / \alpha = \frac{-1/\alpha + z^{\frac{-(\alpha-1)}{2}} - z^{\frac{-(\alpha-1)}{2}-1} + z^{-\alpha} / \alpha}{1-z^{-1}} \quad (8)$$

This filter can be implemented directly by the following difference equation:

$$y[n] = y[n-1] - x[n] / \alpha + x \left[ n - \frac{(\alpha-1)}{2} \right] - x \left[ n - \frac{(\alpha-1)}{2} - 1 \right] + x[n-\alpha] / \alpha \quad (9)$$

Getting amplitude response for this filter is mathematically complex. Nevertheless, theoretically this filter must have the same cut frequency of the subjacent low-pass filter in inverse order. Furthermore, the values of phase response and group delay of the high-pass filter are the equal to the same parameters for the low-pass filter (Smith, 1999).

For a cut frequency of 430 Hz,  $\alpha$  values and associated cut frequency (-3 dB.) are shown on Table 3.

Valor de $\alpha$	Frecuencia de Corte
850	0.2 Hz.
320	0.5 Hz.
35	5 Hz.

Table 3. Cut Frequencies of High-Pass Lynn Filter

Figures 14, 15 and 16 show the low-pass filter amplitude response which give an idea of the amplitude response of the associated high-pass filter because the cut frequencies are the same.

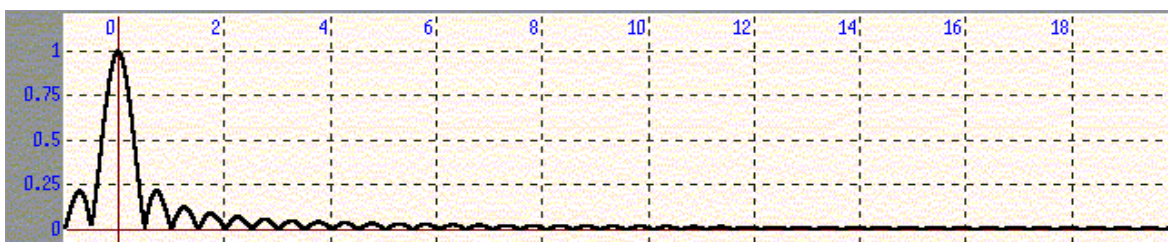

Fig. 14. Low-Pass / High-Pass Lynn's Filter Amplitude Response - Cut Frequency 0.2 Hz



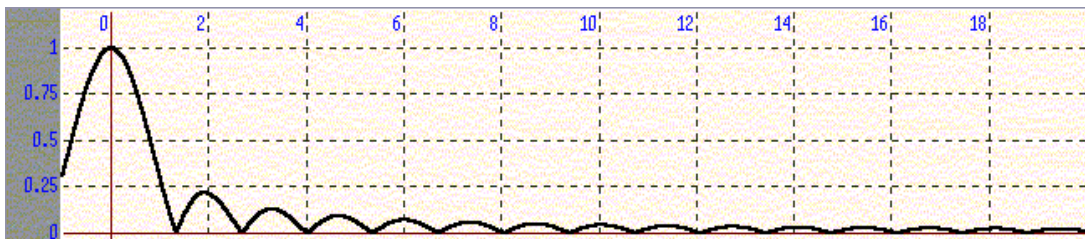

Fig. 15. Low-Pass / High-Pass Lynn's Filter Amplitude Response - Cut Frequency 0.5 Hz

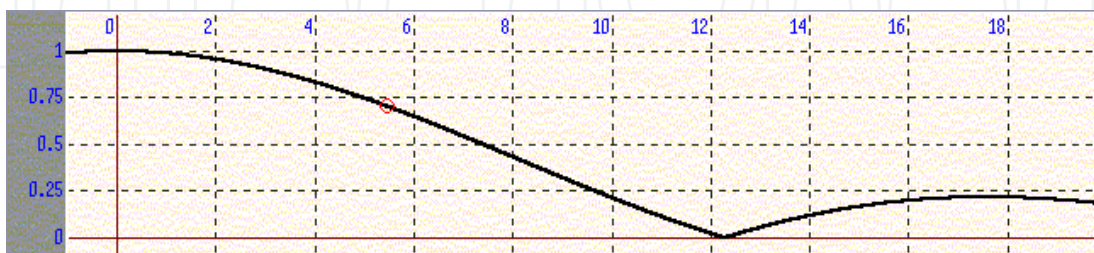

Fig. 16. Low-Pass / High-Pass Lynn's Filter Amplitude Response - Cut Frequency 5 Hz

Figures 17, 18, 19, 20 and 21 present signals registered by an implement ECG device using Figure 4 and 5 circuits (Vidal & Gatica, 2010). Figure 15 shows a pure signal ECG without applying filters to delete noise. Figure 18 shows the 35 Hz low-pass Lynn's filter application on the Figure 17 signal. Figure 18 presents the application of a 48 Hz low-pass filter application over the Figure 17 signal. In Figures 20 and 21 the application of 0.2 and 0.5 high-pass Lynn's filters respectively on the Figure 17 signal is shown. It is important to be aware of the group delay effect on the ECG signal after the 0.2 Hz high-pass Lynn's filter application, 423 samples in this case (around 1 second). Likewise, for the 0.5 Hz high-pass Lynn's filter application there is a group delay of 160 samples.

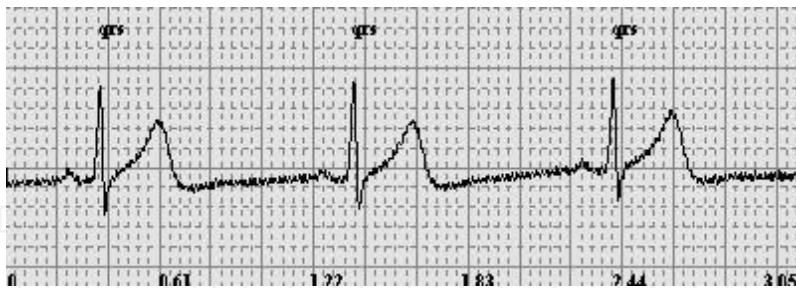

Fig. 17. Pure ECG Signal

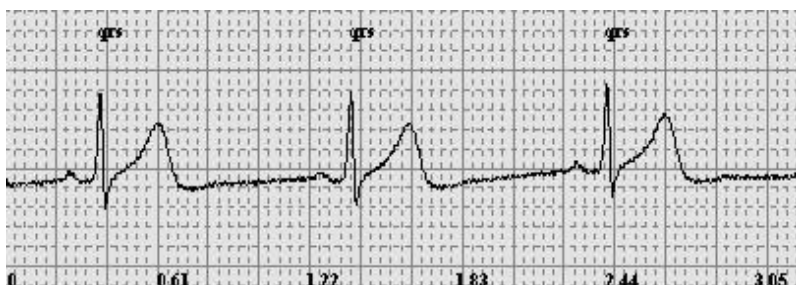

Fig. 18. Filtered ECG Signal Using Low-Pass 35 Hz Lynn's Filter



Fig. 19. Filtered ECG Signal Using Low-Pass 48 Hz Lynn's Filter

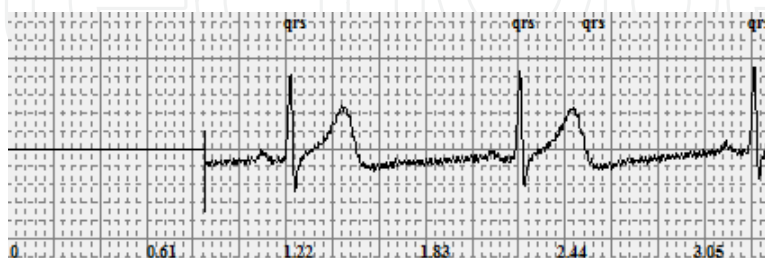

Fig. 20. Filtered ECG Signal Using High-Pass 0.2 Hz Lynn's Filter

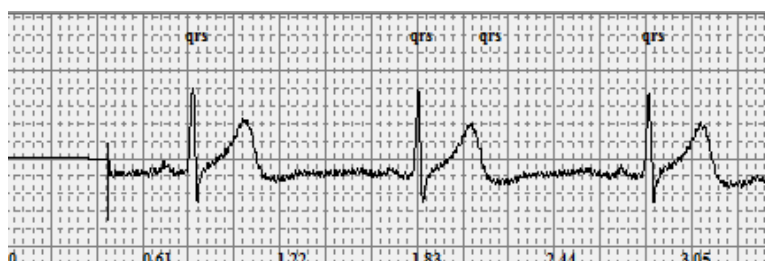

Fig. 21. Filtered ECG Signal Using High-Pass 0.5 Hz Lynn's Filter

The filters application allows improving the ECG signal quality in a remarkable manner. Figure 22 shows the application of a low-pass Lynn's filter of 48 Hz and a high-pass Lynn's filter of 0.5 Hz.

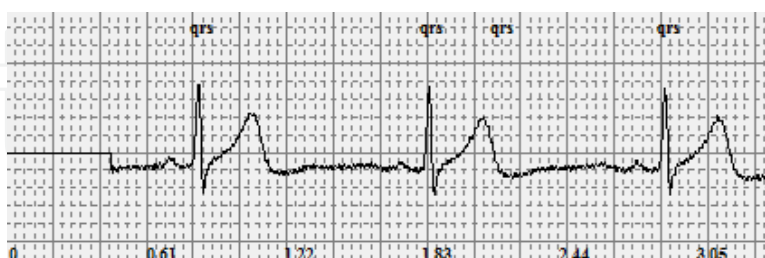

Fig. 22. Filtered ECG Signal Using a Low-Pass 48 Hz Lynn's Filter and a High-Pass 0.5 Hz Lynn's Filter

#### 4.2 QRS detection algorithm on ECG signal

Within the automatic detection waveform of the ECG signal, it is important to detect QRS complex (Cuesta, 2001; Vidal & Pavesi, 2004). This is the dominant feature of the ECG signal. The QRS complex marks the beginning of the contraction of the left ventricle, so the detection of this event has many clinical applications (Vidal et al., 2008; Townsend, 2001).

In the literature there are several algorithmic approaches for detecting QRS complexes of ECG signal with pre-filtering of the signal (Thakor et al., 1984)

The implementation of incremental improvements to a classical algorithm to detect QRS complexes was realized in an experiment as mentioned in (Vidal et al., 2008; Vidal & Gatica, 2010) which in its original form do not have a great performance. The first improvement based on the first derivative is proposed and analyzed in (Friese et al., 1990). The second improvement is based on the use of nonlinear transformations proposed in (Pan & Tompkins, 1985) and analyzed in (Suppappola & Ying, 1994; Hamilton & Tompkins, 1986). The third is proposed and analyzed in (Vidal & Pavesi, 2004; Vidal et al., 2008), as an extension and improvement of that is presented in (Friesen et al., 1994) using characteristics of the algorithm proposed in (Pan & Tompkins, 1985). It should be noted that the three algorithmic improvements recently mentioned, used classical techniques of DSP (Digital Signal Processing). It is noteworthy to indicate that the second improvement proposed in (Pan & Tompkins, 1985) is of great performance in the accurate detection of QRS complexes, for even the modern technology are not able to provide better results.

To test the algorithms that work on ECG signal, it is not necessary to implement a data acquisition system. There are specialized databases with ECG records for analyzing the performance of any algorithm to work with ECG signals (Cuesta, 2001; Vidal & Pavesi, 2004). One of the most important is the MIT DB BIH (database of arrhythmias at Massachusetts Institute of Technology,) (MIT DB, 2008).

In Tables 4, 5, 6 and 7, respectively, are the results obtained with the application of incremental improvements made to the first algorithm for detecting QRS complexes in some records at MIT DB BIH. A good level of performance reached in the final version of algorithm of detection of QRS complexes implemented in this work could be appreciated, (Table 7), compared to its original version (Table 4)

Signal	Pulses Heart (NL)	True Positives (PV)	False Positives (PF)	False Negatives (NF)	(PF + NF) / NL
R. 1118 - S. 1	2278	2278	79676	0	3497,63%
R. 118 - S. 2	2278	2278	77216	0	3389,64%
R. 108 - S. 1	562	562	8933	0	1589,50%
R. 108 - S. 2	562	562	17299	0	3078,11%

Table 4. Results obtained with the Holsinger Algorithm in its Original version, for some of the MIT Database records.

Signal	Pulses Heart (NL)	True Positives (PV)	False Positives (PF)	False Negatives (NF)	(PF + NF) / NL
R. 1118 - S. 1	2278	1558	874	720	69,97%
R. 118 - S. 2	2278	1650	798	628	62,60%
R. 108 - S. 1	562	346	246	216	82,20%
R. 108 - S. 2	562	490	182	72	45,20%

Table 5. Results obtained with the Holsinger Algorithm in its Modified version 1, for some of the MIT Database records.



Signal	Pulses Heart (NL)	True Positives (PV)	False Positives (PF)	False Negatives (NF)	(PF + NF) / NL
R. 1118 - S. 1	2278	2265	4	13	0,5%
R. 118 - S. 2	2278	2263	11	15	1,80%
R. 108 - S. 1	562	538	35	24	10,49%
R. 108 - S. 2	562	524	76	38	20,28%

Table 6. Results obtained with the Holsinger Algorithm Modified Version 2, for some of the MIT Database records

Signal	Pulses Heart (NL)	True Positives (PV)	False Positives (PF)	False Negatives (NF)	(PF + NF) / NL
R. 1118 - S. 1	2278	2265	1	1	0,08%
R. 118 - S. 2	2278	2263	1	2	0,13%
R. 108 - S. 1	562	542	1	15	2,84%
R. 108 - S. 2	562	538	23	21	7,82%

Table 7. Results obtained with the Holsinger Algorithm Modified Version 3, for some of the MIT Database records

## 5. Conclusion

The implementation of equipments for the acquisition and processing of bioelectrical human signals such as the ECG signal is currently a viable task. This chapter is a summary of previous works with simple equipment to work with the ECG signal. Currently the authors are working on:

- Improvements to the work done:
- Increase the number of leads purchased. The A/D converter allows up to 11 simultaneous inputs and supports a sampling rate of 32 KHz. Under certain conditions. 12 simultaneous leads are required for a professional team.
- Modify RC filters in the filter stage for more elaborate filters to ensure a better discrimination of the frequencies that are outside the pass-band.
- Include isolation amplifiers to increase levels for the security of patients, isolating the direct loop with the computer, which is generated with the design proposed in this chapter. Even with the probability of a catastrophe to occur which are low, but the possibility exists and such massive use should be avoided, before including these amplifiers.
- Unifying routine readings of A/D converter and display of results.
- Certify the technical characteristics of the circuits mounted in order to validate its massive use.

### Future works:

- Increase the use of this equipment for capturing other bioelectrical signals such as electroencephalographic and electromyographic.
- Implement a tool to validate algorithms of detection QRS, based on the MIT DB.

- Apply wavelets in the design and implementation of filtering algorithms and detector of waveforms.
- Analyze other techniques for detection of parameters like, fuzzy logic, genetic approaches and neural networks.
- Make use of information technologies, such as a database in order to obtain relevant information of the patients and their pathologies.

Finally, this work is a good demonstration of the potential applications of Hardware - Software, especially in the field of biotechnology. The quantity and quality of the possible future works show the validity of the affirmation in academic and professional aspects. In addition to the likely use of this work in medical settings, it also gives account of the scope of works such as ECG digital, which are practically limitless.

## 6. Acknowledgment

To Dr. David Cuesta of the Universidad Politécnica de Valencia for his valuable contributions and excellent disposition to the authors of this work; to cardiologist Dr. Patricio Maragaño, director of the Regional Hospital of Talca's Cardiology department, for his clinical assessment and technical recommendations for the development of the algorithmic procedures undertaken.

## 7. References

- Ahlstrom, M. L.; Tompkins, W. J. (1985). Digital Filters for Real-Time ECG Signal Processing Using Microprocessors, *IEEE Transaction on Biomedical Engineering*, Vol.32, No.9, (March 2007), pp. 708-713, ISSN 0018-9294
- Clusin, W. T. (2008). Mechanisms of calcium transient and action potential alternans in cardiac cells and tissues. *American Journal of Physiology, Heart and Circle Physiology*, Volume 294, No 1, (October 2007), H1-H10, Maryland, USA.
- Cuesta, D. (September 2001). Estudio de Métodos para Procesamiento y Agrupación de Señales Electrocardiográficas. *Doctoral Thesis, Department of Systems Data Processing and Computers (DISCA) , Polytechnic University of Valencia, Valencia, Spain.*
- Dubin, D. (August 1976). *Electrocardiografía Práctica : Lesión, Traslado e Interpretación*, McGraw Hill Interamericana, 3rd edition, ISBN 978-968-2500-824, Madrid, Spain
- Goldschlager, N. (June 1989). *Principles of Clinical Electrocardiographic*, Appleton & Lange, 13th edition, ISBN 978-083-8579-510, Connecticut, USA
- Friesen, G. M.; Janett, T.C.; Jadallah, M.A.; Yates, S.L.; Quint, S. R.; Nagle, H. T. (1990). A Comparison of the Noise Sensitivity of Nine QRS Detection Algorithms, *IEEE Transactions on Biomedical Engineering*, Vol.31, No.1, (January 1990), pp. 85-98., ISSN 0018-9294
- Hamilton, P. S.; Tompkins, W. J. (1986). Quantitative Investigation of QRS Detection Rules Using MIT/BIH Arrhythmia Database, *IEEE Transactions on Biomedical Engineering*, Vol.31, No.3, (March 2007), pp. 1157-1165, ISSN 0018-9294
- Kohler, B. -U.; Henning, C.; Orglmeister, R. (2002). The Principles of Software QRS Detection, *IEEE Engineering in Medicine and Biology*, Vol.21, No.1, (January-February 2002), pp. 42-57, ISSN 0739-5175
- IEEE Transactions on Biomedical Engineering*, Vol.31, No.11, (November 1984), pp. 702-706, ISSN 0018-9294

- Lindner, D. (January 2009). *Introduction to Signals and Systems*, Mc Graw Hill Company, First Edition, ISBN 978-025-6252-590, USA
- MIT DB. (2008). , MIT-BIH Arrhythmia Database, 20.06.2011, Available from <http://www.physionet.org/physiobank/database/mitdb/>
- Pan, J.; Tompkins, W. J. (1985). A Real-Time QRS Detection Algorithm, *IEEE Transactions on Biomedical Engineering*, Vol.32, No.3, (March 2007), pp. 230-236, ISSN 0018-9294
- Proakis, J.; Manolakis, D. (2007). *Digital Signal Processing: Principles, Algorithms, and Applications*, Prentice Hall, 3rd edition, ISBN 978-013-3737-622, New Jersey, USA
- Smith, S. W. (1999). *The Scientist and Engineer's Guide to Digital Signal Processing*, Second Edition, California Technical Publishing, 1999, ISBN 978-096-6017-632, California, USA
- Suppappola, S; Ying, S. (1994). Nonlinear Transform of ECG Signals for Digital QRS Detection: A Quantitative Analysis, *IEEE Transactions on Biomedical Engineering*, Vol.41, No. 4, (April 1994), pp. 397-400, ISSN: 0018-9294
- Thakor, N. V.; Webster, J.; Tompkins, W. J. (1984). Estimation of QRS Spectra for Design of a QRS Filter, *IEEE Transactions on Biomedical Engineering*, Vol.31, No.11, (2007), pp. 702-706, ISSN 0018-9294
- Townsend, N. (2001). Medical Electronics, *Signal Processing & Neural Networks Group, Dept. of Engineering Science, University of Oxford*, 21.06.2011, Available from [http://www.robots.ox.ac.uk/~neil/teaching/lectures/med\\_elec/](http://www.robots.ox.ac.uk/~neil/teaching/lectures/med_elec/)
- Vidal, C.; Pavesi, L. (January 2004). Implementación de un Electrocardiográfico Digital y Desarrollo de Algoritmos Relevantes al Diagnóstico Médico. *Bachelor Thesis, Computer Engineering, Catholic University of Maule, Talca, Chile*
- Vidal, C.; Charnay, P.; Arce, P. (2008). Enhancement of a QRS Detection Algorithm Based on the First Derivative Using Techniques of a QRS Detector Algorithm Based on Non-Linear Transformation, *Proceedings of IFMBE 2008 4th European Conference of the International Federation for Medical and Biological Engineering*, Volume 22, Part 6, pp. 393-396, ISBN 978-354-0892-076, Antwerp, Belgium, December 2009
- Vidal, C.; Gatica, V. (2010). Design and Implementation of a Digital Electrocardiographic System, *University of Antioquia Engineering Faculty Scientific Magazine*, No. 55, (September 2010), pp. 99-107, ISSN 0120-0230, Antioquia, Colombia
- Wells, J. K.; Crampton, W. G. R. (2006). A Portable Bioamplifier for Electric Fish Research: Design and Construction, *Neotropical Ichthyology*, Volume 4, (2006), pp. 295-299, ISSN 1679-6225, Porto Alegre, Brazil

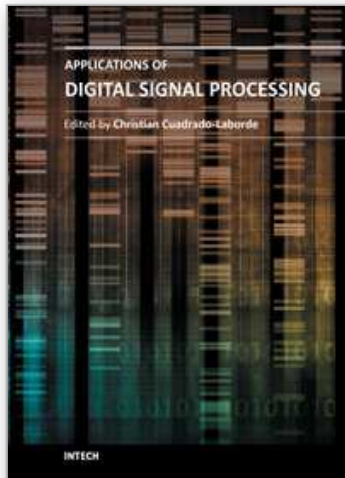

## **Applications of Digital Signal Processing**

Edited by Dr. Christian Cuadrado-Laborde

ISBN 978-953-307-406-1

Hard cover, 400 pages

**Publisher** InTech

**Published online** 23, November, 2011

**Published in print edition** November, 2011

In this book the reader will find a collection of chapters authored/co-authored by a large number of experts around the world, covering the broad field of digital signal processing. This book intends to provide highlights of the current research in the digital signal processing area, showing the recent advances in this field. This work is mainly destined to researchers in the digital signal processing and related areas but it is also accessible to anyone with a scientific background desiring to have an up-to-date overview of this domain. Each chapter is self-contained and can be read independently of the others. These nineteenth chapters present methodological advances and recent applications of digital signal processing in various domains as communications, filtering, medicine, astronomy, and image processing.

### **How to reference**

In order to correctly reference this scholarly work, feel free to copy and paste the following:

Cristian Vidal Silva, Andrew Philominraj and Carolina del Río (2011). A DSP Practical Application: Working on ECG Signal, Applications of Digital Signal Processing, Dr. Christian Cuadrado-Laborde (Ed.), ISBN: 978-953-307-406-1, InTech, Available from: <http://www.intechopen.com/books/applications-of-digital-signal-processing/a-dsp-practical-application-working-on-ecg-signal>

**INTECH**  
open science | open minds

### **InTech Europe**

University Campus STeP Ri  
Slavka Krautzeka 83/A  
51000 Rijeka, Croatia  
Phone: +385 (51) 770 447  
Fax: +385 (51) 686 166  
[www.intechopen.com](http://www.intechopen.com)

### **InTech China**

Unit 405, Office Block, Hotel Equatorial Shanghai  
No.65, Yan An Road (West), Shanghai, 200040, China  
中国上海市延安西路65号上海国际贵都大饭店办公楼405单元  
Phone: +86-21-62489820  
Fax: +86-21-62489821

© 2011 The Author(s). Licensee IntechOpen. This is an open access article distributed under the terms of the [Creative Commons Attribution 3.0 License](#), which permits unrestricted use, distribution, and reproduction in any medium, provided the original work is properly cited.

IntechOpen

IntechOpen